



VariTrane VAV Terminal Unit

Single-Duct
Series Fan-Powered
Parallel Fan-Powered



Contents

VAV System Overview	3
VariTrane VAV Terminal Unit Overview	5
Model Description – Single-Duct Terminal Units	8
Model Description – Fan-Powered Terminal Units	9
Performance Data – Single-Duct Terminal Units	10
Performance Data – Series Fan-Powered Terminal Units	15
Performance Data – Parallel Fan-Powered Terminal Units	22

VAV System Overview

System Introduction

In a Variable Air Volume (VAV) system, air delivery volume varies directly with the changing cooling or heating load, thus saving energy at part load conditions. Another benefit that makes VAV a popular choice in HVAC design is its capability to control temperature in multiple zones. Compared to conventional constant volume system, VAV system has multiple VAV terminal boxes each serving a zone controlling air flow to that zone and maintaining the set-point temperature.

Trane leads in VAV technology with its innovative range of VariTrane units (Single-duct and Fan-powered types) that are designed for diverse applications and environments. Applications include office space, hospitals, hotels, retail stores, malls and educational facilities. VariTrane provides the most reliable and flexible products available, further enhanced by Trane DDC controls in implementing systems-level control strategies like ventilation reset and Static Pressure Optimization to improve systems performance and efficiency.

VAV System Features and Benefits

VAV systems have the following features and benefits:

1. Economical Operation

VAV systems can change the supply air volume according to the cooling and heating load variation to enable the cooling, heating capacity and fan power to meet actual load requirement. Therefore, the system energy consumption can be significantly reduced. Meanwhile, if compared with traditional air

conditioning systems, VAV systems can utilize the outdoor fresh air as much as possible during transitional seasons, which not only saves energy consumption, but also improves indoor air quality. It is estimated that over 30% of the annual energy consumption can be saved and 10-30% of total equipment capacity can be reduced by using VAV system.

2. Improved Indoor Air Quality and Comfort

With the integrated DDC control, VariTrane VAV terminal units can keep room temperature and air volume within the pre-set range per actual cooling or heating load requirement and enhance control accuracy of the terminal unit. It allows room temperature to be adjusted per application requirement. Supply air of VAV system can be remote and centralized controlled to improve the system efficiency and room air quality.

3. Reliable Operation, Simple Construction

VAV system is an all-air system. There is no water piping passing through the ceiling of the room, which can avoid problems such as condensation, water leakage and bacteria breeding which may happen in the fan coil system. In addition, VariTrane VAV boxes have simple casing construction, which makes installation simple and easy.

4. Flexible System

Renovation always occurs in modern buildings. By using flexible duct connection, modification of VariTrane VAV terminal unit position can be done according to the room partition and requirement with minimum field modification cost, labor and time.

5. Compatible System

VAV systems can be integrated with other air conditioning systems to optimize performance efficiency. For example, when integrated with ice storage system, the application of cold air distribution can reduce the initial investment of ice storage system effectively; when integrated with heat pump system it can reduce the initial investment, reducing the noise level by installing several water heat pumps in central location and avoid costly installation of heat pump at each floor.

6. Easy to get integrated with Building Automation (BA) system

VAV systems can be integrated to BA system via DDC control. System optimization and monitoring of the whole system can be achieved by computerized control.

VAV System Structure

A typical VAV System consists of:

1. Air handling units
2. Air duct system
3. VariTrane VAV terminal unit

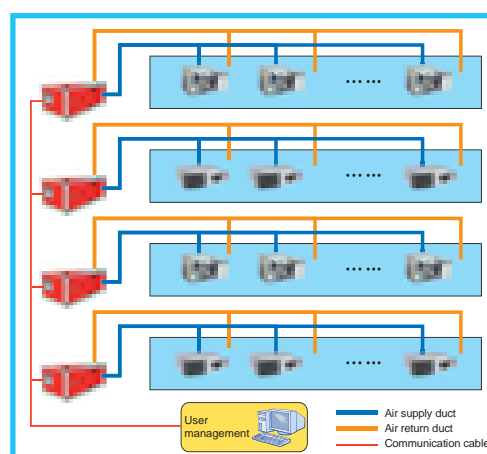

VAV System Schematic

VAV System Overview

System Control Introduction

The VariTrane VAV box can be connected to Trane's Building Automation System through two types of control systems.

Tracer System

In Tracer, the work station using Tracer Summit software monitors the whole system and has many functions such as operating parameter setting, data acquisition, alarming, reports, clock, etc. The Building control Unit (BCU) provides control logic for the whole system and coordinates the operation between equipment level controllers such as MP581 and VAV controllers. VAV controllers are connected to each other by using RS485, and then connected to BCU. The whole control system structure is simple, compatible and designed to accommodate future extension requirements.

In addition, using LonTalk DDC controllers, VariTrane VAV terminal units can be connected to third party control systems which have LonTalk protocol.

Tracker system

In Tracker, the work station is connected to a Tracker controller. It acquires equipment status, system data information, control command and monitors the system equipment. The Tracker controller provides control logic for the whole system. It coordinates the rooftop equipment (Voyager) & VariTrane VAV terminal unit control through the CCP (central control panel). One Tracker controller can be connected to several CCPs, and each CCP is connected to one rooftop unit (Voyager) and several VariTrane VAV boxes. Inter communication is possible between CCPs. All equipment connections in the system are PnP (plug and play), making it convenient for installation and application.

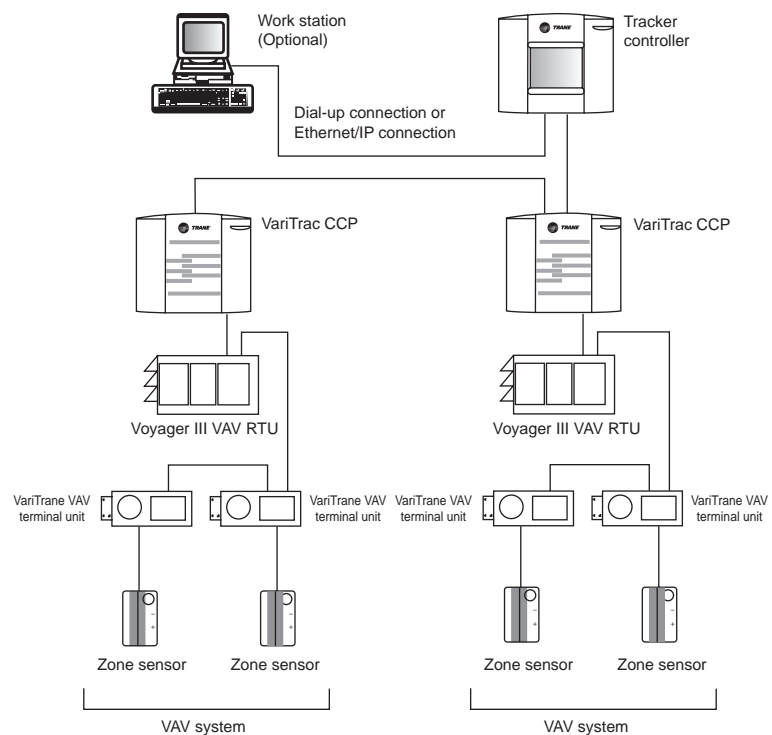
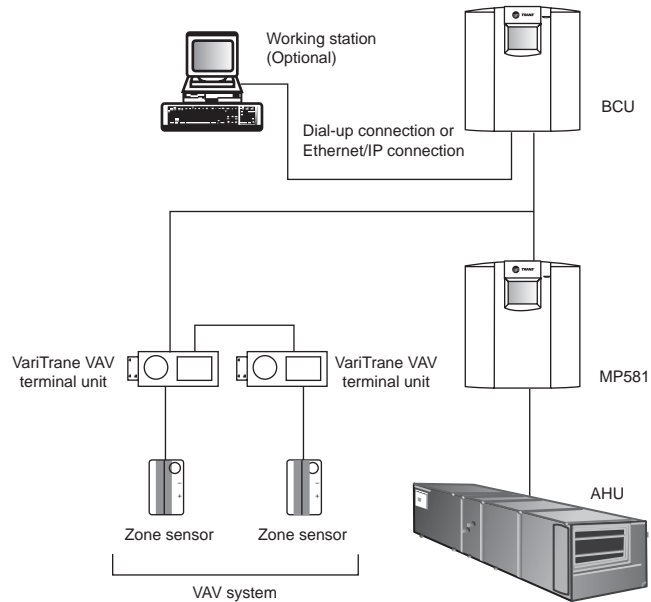

VariTrane VAV Terminal Unit Overview

VAV Terminal Unit Classification

A VAV terminal unit controls the air valve opening and regulates the air volume in the room by measuring the temperature difference between room and set point. There are two basic working principles of a VAV box: pressure-dependent and pressure-independent.

A pressure-dependent VAV control scheme uses the space temperature sensor to control the position of the modulating device directly. The actual

airflow delivered to the space depends on the duct system static pressure at the inlet of the terminal unit. Although the space temperature sensor will continually correct the position of the modulating device, the response can be sluggish and cause unacceptable temperature variations within the space.

In contrast, a pressure-independent VAV control scheme controls the actual volume of primary air that flows to the space. An airflow-measuring device on the terminal unit makes it possible. The position of the modulation device

is not directly controlled and is basically a by-product of regulating the airflow through the unit. Because the airflow delivered to the space is directly controlled, it is independent of inlet static pressure.

Pressure-independent control increases the stability of airflow control and allows minimum and maximum airflow settings to become actual airflows rather than physical positions of the modulation device. It is clearly most popular in all VAV terminal unit controls.

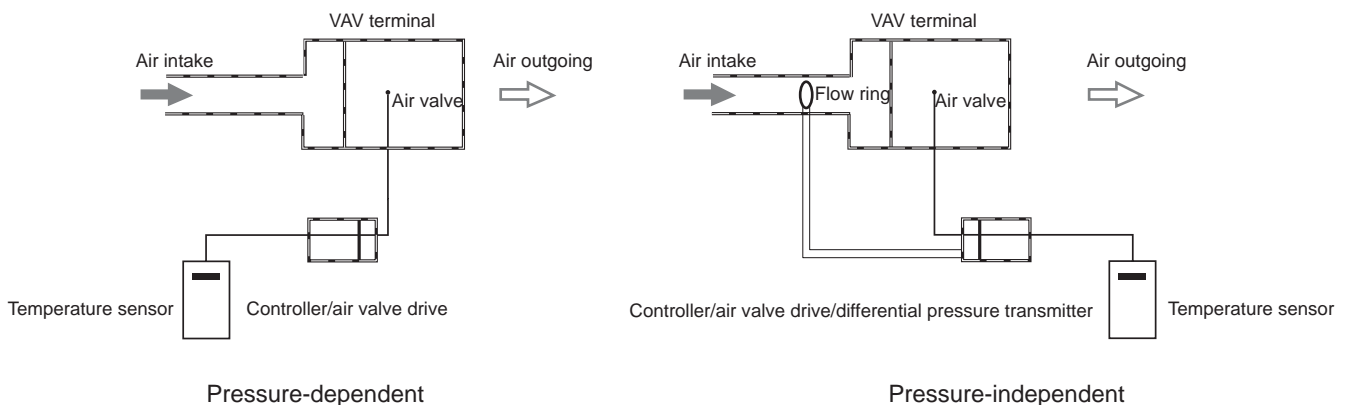

There are three basic types of VariTrane VAV terminal units, Single-duct (without fan), Series Fan-Powered and Parallel Fan-Powered.

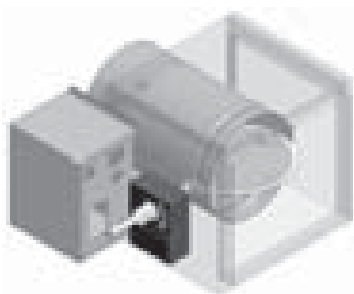

Single-duct

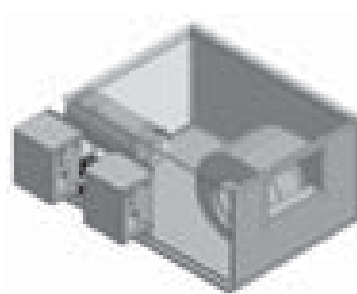

Series fan-powered

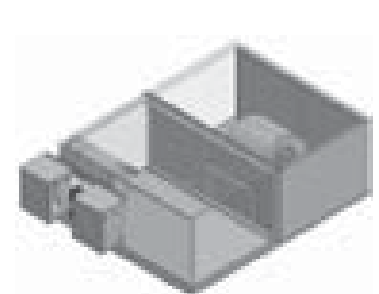

Parallel fan-powered

VariTrane VAV Terminal Unit Overview

Features and Benefits

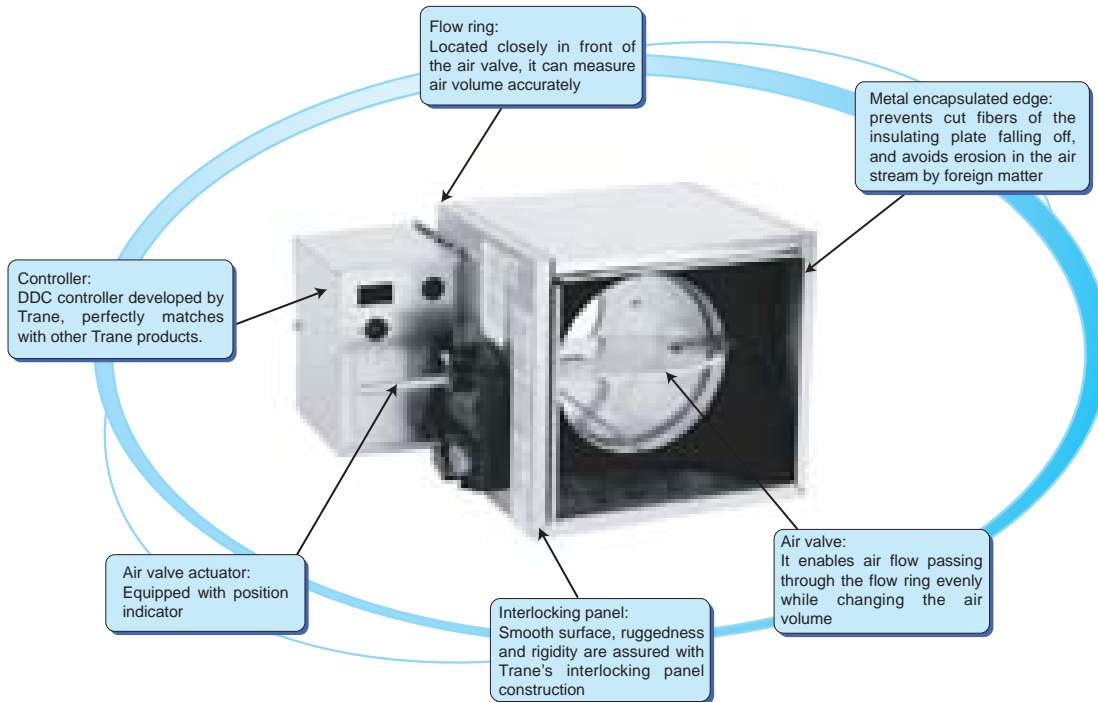

Energy Efficiency

VAV systems can save energy significantly, comply with ventilation requirements, and provide reliable and personalized occupant control.

Energy saving features of VariTrane VAV terminal units include:

1. System strategies like Ventilation Reset, and Static Pressure Optimization, etc
2. Night setback
3. Occupied/unoccupied control
4. Demand controlled ventilation
5. EarthWise System utilizing low temperature air and system energy optimization.

Advanced Control

With years of working experience and understanding of VAV system characteristic, Trane has developed a reliable DDC controller for VAV system which has unique functions:

1. **Advanced system integration**—VariTrane VAV terminal unit DDC controller uses pressure-independent control mode, which can obtain precise air valve opening by doing two-time PID calculation according to the temperature and air flow to control air volume accurately and provide excellent indoor air quality and comfort control. It can also be integrated with Trane Tracer Summit Building Automation System. It is the most

advanced VAV control system in the field. This system has a series of unique control modes such as fresh air volume / ventilation reset, static pressure optimization control which can meet the current industry regulations and standards, able to adjust air duct static pressure effectively and reduce energy consumption of the fan to improve the whole VAV system efficiency.

2. **Superior product quality**—Both VariTrane VAV system terminal units and control devices are provided by Trane, which ensures the product quality, system compatibility and perfect system integration.

VAV Terminal Unit Overview

Controls Parts and Options

UCM4 is a microprocessor-based DDC controller using pressure-independent control mode to control the supply air volume accurately to make room temperature reach the set condition. In addition, UCM4 also has additional functions, such as optional CO₂ sensor, wireless sensor, to fulfill various customer and application requirements.

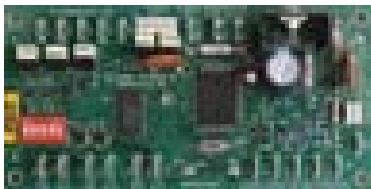

UCM4

VV550/551 is a LonTalk protocol-based DDC controller which can provide precise control to VariTrane VAV terminal unit. It also has good universality and compatibility, especially in connecting to the third party Building Automation System with LonTalk protocol.

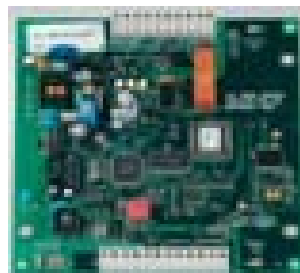

VV550/551

Wireless sensor eliminates the wiring difficulty at the field and provides more flexibility for layout and sensor positioning. Trane wireless sensor is based on wide spectrum technology, This enhances system security greatly and avoids interference problem when using different system with the same frequency in the same area.

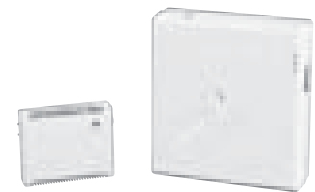

Wireless sensor

CO₂ sensor is used to measure CO₂ concentration in the air, converts it into electrical signal and then transmit the signal to the controller which will reset fresh air volume accordingly to ensure indoor air quality and comfort.



Wall mounted

Duct mounted

Auxiliary temperature sensor helps VariTrane VAV terminal unit changeover between heating and cooling mode automatically without the system controller. Terminal unit controller will compare the temperature differences between the supply air temperature provided by auxiliary temperature sensor and the room temperature provided by zone sensor. It will determine the working mode automatically according to the result without manual adjustment.

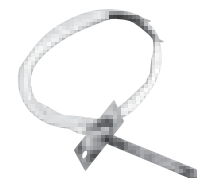

Auxiliary temperature sensor

Area sensor

Model	Zone sensor		Occupied / Unoccupied Mode		LCD
	Temperature setting	Internal sensor	ON	CANCEL	
4190 1090	√	√	√	√	
4190 1120	√	√	√	√	√



4190 1090



4190 1120



VariTrane Model Description Single-Duct

V C C T 0 6 0 0 0 A 0 D D 0 1 D 0 0 0 0 0 L 0 0 0 0 0 0 0 0 0 0
 1 2 3 4 5 6 7 8 9 10 11 12 13 14 15 16 17 18 19 20 21 22 23 24 25 26 27 28 29 30 31 32

Digit 1~2— Unit Type		DD11 LonTalk DDC cooling only	0 N/A
VC	Single duct	DD12 LonTalk DDC N.C. on/off water valve	1 115VAC/24V AC transformer 3 230VAC/24V AC transformer
Digit 3— Terminal Heating Mode		DD13 LonTalk DDC prop hot water valve	Digit 24— Power Disconnect
C	None	DD14 LonTalk DDC on/off electric heat control	0 N/A W With
E	Electric heating	FM00 Customers supply the air valve actuator and controller by themselves	Digit 25— Power Fuse
W	Hot water heating		0 N/A W With
Digit 4— Development Series No.		Digit 16 — Insulation	Digit 26— Electric Heating Voltage
T	China plant	B 1" Matte-faced	0 N/A C Single-phase 220V J Three-phase 380V
Digit 5~6— Dimension of Primary Air Valve Inlet		D 1" foil faced	Digit 27~29— Electric Heating Power
05	5"	F 1" Double-wall	000 N/A 010 1.0kW 020 2.0kW 300 30kW
06	6"	G 3/8" Closed-cell	Note: For detailed specification, refer to the electric heater information
08	8"	Digit 17— Reserved	Digit 30— Electric Heat Stage
10	10"	0 N/A	0 N/A 1 1 stage 2 2 stages 3 3 stages
12	12"	Digit 18— Reserved	Digit 31— Reserved
14	14"	0 N/A	0 N/A
16	16"	Digit 19—Reserved	Digit 32— Reserved
Digit 7~8— Reserved		0 N/A	
00	N/A	Digit 20— Reserved	
Digit 9 —Reserved		0 N/A	
0	N/A	Digit 21— Hot Water Coil	
Digit 10~11— Design No.		0 N/A	
A0	Initial development	1 1 row 2 2 rows	
Digit 12~15— Control Mode		Digit 22—Electric Connection	
DD00	Trane elec actuator only	L Left type	
DD01	DDC cooling only	Digit 23— Transformer	
DD02	DDC N.C. on/off water valve		
DD03	DDC prop hot water valve		
DD04	DDC on/off electric heat control		



VariTrane Model Description Fan-Powered

V S C T 0 6 0 0 P A 0 D D 0 1 D D 5 2 0 0 L 0 0 0 0 0 0 0 0 0 0
 1 2 3 4 5 6 7 8 9 10 11 12 13 14 15 16 17 18 19 20 21 22 23 24 25 26 27 28 29 30 31 32

Digit 1~2— Unit Type		control	3	1 row —Outlet—Left	
VP	Parallel fan-powered	DD11	LonTalk DDC cooling only	5	2 rows—Outlet—Left
VS	Series fan-powered	DD12	LonTalk DDC N.C. on/off	Digit 22—Electrical Connections	
Digit 3— Terminal Heating Mode		water valve	L	left	
C	None	DD13	LonTalk DDC prop hot water valve	Digit 23— Reserved	
E	Electric heating	DD14	LonTalk DDC on/off electric	0	N/A
W	Hot water heating	heat control		Digit 24— Power Disconnect	
Digit 4—Development Series No		FM00	Customers supply the air	0	N/A
T	China plant	valve actuator and controller		W	with
Digit 5~6— Primary Air Valve		by themselves		Digit 25— Power Fuse	
05	5"	Digit 16— Thermal Insulation		0	N/A
06	6"	B	1" Matte-faced	W	with
08	8"	D	1" foil faced	Digit 26— Electric Heating Voltage	
10	10"	F	1" Double-wall	0	N/A
12	12"	G	3/8" Closed-cell	C	Single-phase 220V
14	14"	Digit 17— Motor Type		J	Three-phase 380V
16	16"	D	Standard motor	Digit 27~29— Electric Heating Power	
Digit 7~8— Reserved		Digit 18— Motor Voltage		000	N/A
00	N/A	1	115V/60Hz/1P	010	1.0kW
Digit 9— Fan model		4	230V/60Hz/1P	020	2.0kW
P	02SQ	5	230V/50Hz/1P	~	~
Q	03SQ	Digit 19— Outlet Connection		200	20kW
R	04SQ	1	Flange connection	Note: For detailed specification, refer to the electric heater information	
S	05SQ	2	Slip & Drive	Digit 30—Electric Heat Stage	
T	06SQ	Digit 20— Attenuator		0	N/A
U	07SQ	0	N/A	1	1 stage
Digit 10~11— Design No.		W	With	2	2 stages
A0	Initial development	Digit 21— Hot Water Coil		3	3 stages
Digit 12~15— Control Mode		0	N/A	Digit 31— Reserved	
DD00	Trane elec actuator only	1	1 row – inlet (only for parallel fan-powered)	0	N/A
DD01	DDC cooling only	fan-powered)		Digit 32— Airflow Switch	
DD02	DDC N.C. on/off water valve	2	2 rows – inlet (only for parallel fan-powered)	0	N/A
DD03	DDC prop hot water valve			W	With
DD04	DDC on/off electric heat				

Performance Data VariTrane Single-Duct

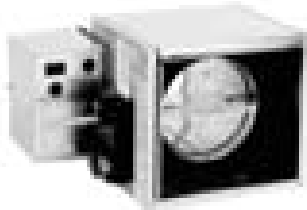

VCCT single-duct terminal device
(cooling only)

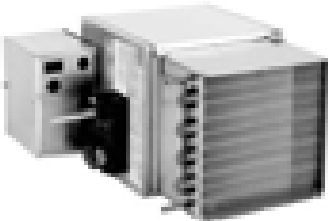

VCWT heating-water heating
terminal device

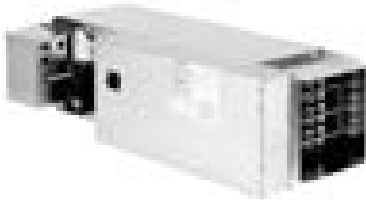

VCET electric heating terminal device

Performance Data

Air valve	Inlet diameter mm	Airflow range m ³ /h	Min. airflow m ³ /h	Dimension mm(L x W x H)	Weight (kg)
05	127	68-595	68	443x433x241	9.5
06	152	101-850	101	411x433x241	9.5
08	203	180-1530	180	398x458x292	10
10	254	277-2380	277	424x534x343	14
12	305	400-3400	400	449x610x394	17
14	356	544-5100	544	475x661x495	21
16	406	713-6800	713	500x763x495	23

Air Pressure Drop (Pa)

Single-duct VAV terminal device					
Air valve	Airflow (m ³ /h)	Casing	Heating coil		Electric heater
			1 row	2 row	
05	162	3	5	8	5
	342	3	9	18	8
	504	3	19	38	10
	595	4	25	50	15
06	162	3	5	8	5
	432	13	16	30	8
	594	26	29	53	10
	850	55	57	100	15
08	342	3	5	10	5
	684	4	21	39	10
	1008	9	40	74	15
	1530	21	78	148	15
10	846	3	13	26	10
	1350	3	34	60	15
	1872	3	64	107	20
	2380	3	101	162	20
12	1350	3	21	44	10
	2034	3	44	85	20
	2718	3	73	135	20
	3400	3	108	192	25
14	2520	3	23	52	15
	3402	3	37	86	20
	4248	3	53	124	20
	5100	3	71	168	25
16	3384	3	25	70	20
	4248	3	37	111	20
	5094	3	51	159	25
	6800	3	84	281	25

Note: The air pressure drops in the table refer to the pressure drops of the parts.



Performance Data VariTrane Single-Duct

Heating Capacity of Hot Water Coil (kW)

Air Valve	Coil Rows	Water volume (L/s)	Water pressure drop (kPa)	Air volume (m ³ /h)									
				76	102	153	170	255	340	425	595	680	850
05/ 06	1 Row	0.03	1.57	1.20	1.38	1.66	1.73	2.05	2.30	2.52	2.86	3.01	3.26
		0.06	5.26	1.27	1.49	1.82	1.91	2.31	2.64	2.93	3.41	3.63	4.01
		0.09	10.72	1.30	1.53	1.88	1.98	2.42	2.78	3.10	3.65	3.91	4.35
		0.13	17.82	1.32	1.55	1.91	2.02	2.47	2.86	3.20	3.78	4.06	4.54
		0.16	26.47	1.32	1.56	1.93	2.04	2.51	2.91	3.26	3.87	4.16	4.67
	2 Row	0.06	1.85	1.48	1.88	2.54	2.73	3.53	4.14	4.61	5.29	5.58	6.00
		0.13	6.39	1.52	1.94	2.68	2.90	3.84	4.60	5.22	6.15	6.56	7.19
		0.19	13.28	1.53	1.96	2.72	2.95	3.96	4.77	5.45	6.49	6.96	7.69
		0.25	22.39	1.54	1.97	2.75	2.98	4.01	4.86	5.57	6.68	7.18	7.96
		0.32	33.61	1.54	1.98	2.76	3.00	4.05	4.92	5.65	6.80	7.32	8.14

Scope Size 05
Size 06

Air Valve	Coil Rows	Water volume (L/s)	Water pressure drop (kPa)	Air volume (m ³ /h)									
				280	340	510	680	850	1019	1189	1359	1530	
08	1 Row	0.03	2.12	2.47	2.66	3.12	3.47	3.75	3.99	4.18	4.35	4.50	
		0.06	7.05	2.81	3.06	3.68	4.18	4.61	4.99	5.33	5.63	5.90	
		0.09	14.35	2.94	3.22	3.92	4.49	4.99	5.44	5.84	6.22	6.56	
		0.13	23.82	3.01	3.31	4.05	4.67	5.22	5.71	6.15	6.56	6.93	
		0.16	35.35	3.06	3.37	4.13	4.78	5.36	5.88	6.35	6.79	7.20	
	2 Row	0.13	0.98	4.40	4.97	6.25	7.18	7.88	8.44	8.89	9.26	9.58	
		0.25	3.48	4.54	5.18	6.67	7.79	8.69	9.42	10.03	10.55	11.01	
		0.38	7.37	4.65	5.33	6.92	8.16	9.16	9.99	10.70	11.30	11.83	
		0.50	12.56	4.70	5.40	7.06	8.36	9.42	10.31	11.07	11.72	12.29	
		0.63	19.04	4.74	5.45	7.15	8.49	9.59	10.51	11.30	11.99	12.59	
0.79	28.90	4.77	5.49	7.22	8.60	9.73	10.68	11.50	12.22	12.84			

Air Valve	Coil Rows	Water volume (L/s)	Water pressure drop (kPa)	Air volume (m ³ /h)									
				595	765	934	1104	1274	1444	1699	1869	2209	2380
10	1 Row	0.04	5.29	4.36	4.83	5.21	5.54	5.83	6.08	6.41	6.61	6.94	7.09
		0.06	9.81	4.74	5.27	5.75	6.17	6.54	6.88	7.33	7.60	8.07	8.28
		0.09	19.90	5.09	5.71	6.26	6.75	7.21	7.63	8.21	8.55	9.18	9.47
		0.13	33.00	5.28	5.96	6.56	7.10	7.60	8.07	8.71	9.11	9.84	10.17
		0.16	48.93	5.40	6.11	6.75	7.33	7.87	8.37	9.06	9.48	10.28	10.64
	2 Row	0.13	2.07	7.87	8.98	9.87	10.59	11.20	11.72	12.36	12.73	13.34	13.60
		0.25	7.53	8.64	10.06	11.23	12.23	13.10	13.85	14.81	15.37	16.34	16.75
		0.38	16.15	8.93	10.46	11.76	12.88	13.86	14.72	15.83	16.49	17.62	18.12
		0.50	27.83	9.07	10.68	12.05	13.23	14.27	15.19	16.40	17.10	18.34	18.88
		0.63	42.50	9.17	10.81	12.22	13.45	14.53	15.49	16.75	17.50	18.80	19.38

Air Valve	Coil Rows	Water volume (L/s)	Water pressure drop (kPa)	Air volume (m ³ /h)									
				680	1019	1359	1699	2039	2379	2718	3058	3400	
12	1 Row	0.06	2.04	5.30	6.19	6.88	7.44	7.90	8.29	8.64	8.93	9.20	
		0.13	7.08	6.08	7.28	8.25	9.10	9.85	10.51	11.11	11.65	12.14	
		0.19	14.79	6.40	7.74	8.86	9.84	10.71	11.50	12.23	12.90	13.52	
		0.25	25.04	6.57	8.00	9.20	10.26	11.22	12.09	12.89	13.63	14.33	
		0.32	37.73	6.68	8.16	9.42	10.54	11.55	12.48	13.33	14.13	14.87	
	2 Row	0.13	0.74	9.27	11.32	12.71	13.71	14.47	15.07	15.56	15.97	16.30	
		0.32	4.12	10.42	13.37	15.59	17.33	18.74	19.92	20.91	21.77	22.51	
		0.50	10.01	10.82	14.09	16.63	18.68	20.37	21.80	23.03	24.10	25.04	
		0.69	18.35	11.01	14.44	17.15	19.35	21.20	22.77	24.13	25.32	26.38	
		0.88	29.06	11.12	14.65	17.46	19.77	21.71	23.37	24.81	26.08	27.21	
1.10	44.53	11.21	14.81	17.70	20.08	22.10	23.83	25.34	26.67	27.86			



Performance Data VariTrane Single-Duct

Air Valve	Coil Rows	Water volume (L/s)	Water pressure drop (kPa)	Air volume (m³/h)									
				1189	1529	1869	2209	2549	2888	3398	3908	4417	5100
14	1 Row	0.13	3.69	9.31	10.31	11.21	11.99	12.68	13.30	14.12	14.84	15.47	16.20
		0.19	7.67	10.07	11.26	12.31	13.24	14.11	14.91	15.98	16.94	17.80	18.82
		0.25	12.93	10.49	11.80	12.97	14.01	14.97	15.86	17.08	18.20	19.21	20.43
		0.32	19.43	10.76	12.15	13.39	14.52	15.55	16.51	17.83	19.04	20.16	21.52
		0.38	27.13	10.95	12.40	13.69	14.88	15.97	16.98	18.39	19.67	20.85	22.31
		0.44	36.01	11.09	12.58	13.92	15.14	16.28	17.33	18.80	20.15	21.40	22.92
	2 Row	0.32	3.24	16.31	18.74	20.71	22.34	23.71	24.89	26.38	27.62	28.66	29.83
		0.57	9.93	17.50	20.41	22.85	24.92	26.72	28.28	30.31	32.03	33.51	35.20
		0.82	20.07	18.00	21.13	23.78	26.06	28.06	29.82	32.12	34.08	35.80	37.76
		1.07	33.61	18.27	21.52	24.30	26.71	28.82	30.70	33.16	35.28	37.14	39.28
		1.32	50.49	18.45	21.78	24.64	27.13	29.32	31.28	33.85	36.07	38.02	40.28
		1.42	57.67	18.50	21.85	24.73	27.25	29.47	31.44	34.05	36.30	38.28	40.58

Air Valve	Coil Rows	Water volume (L/s)	Water pressure drop (kPa)	Air volume (m³/h)									
				1529	2039	2549	3058	3398	4078	4757	5437	6116	6800
16	1 Row	0.13	4.10	11.21	12.61	13.75	14.72	15.29	16.29	17.14	17.87	18.52	19.09
		0.19	8.48	12.26	13.90	15.31	16.57	17.33	18.68	19.86	20.90	21.83	22.67
		0.25	14.26	12.86	14.68	16.25	17.65	18.52	20.11	21.51	22.77	23.90	24.93
		0.32	21.39	13.25	15.20	16.89	18.41	19.34	21.06	22.62	24.03	25.32	26.49
		0.38	29.83	13.52	15.56	17.35	18.95	19.95	21.77	23.42	24.95	26.35	27.63
		0.47	44.89	13.80	15.94	17.82	19.53	20.59	22.54	24.32	25.94	27.45	28.87
	2 Row	0.32	3.44	20.13	23.37	25.88	27.88	29.00	30.89	32.41	33.67	34.73	35.64
		0.57	10.45	21.84	25.85	29.08	31.76	33.30	35.94	38.14	39.99	41.59	42.98
		0.82	21.07	22.55	26.92	30.50	33.50	35.25	38.28	40.84	43.02	44.91	46.57
		1.07	35.21	22.95	27.52	31.30	34.50	36.37	39.64	42.41	44.79	46.87	48.71
		1.32	52.82	23.20	27.90	31.82	35.14	37.10	40.53	43.45	45.97	48.18	50.13
		1.42	60.31	23.27	28.01	31.97	35.33	37.31	40.79	43.75	46.32	48.56	50.55

Note: 1, EAT= 12.8°C, EWT= 82.2°C.

2, Capacity based on 12.8°C entering air temperature and 82.2°C entering water temperature. Refer to correction factors for different entering conditions.
Actual Heating capacity = Data in the above table x Temperature Correction factor

Entering water temperature minus entering air temperature EWT-EAT	22	28	33	39	44	56	69	78	83	89	100	111
Temperature correction factor	0.32	0.40	0.48	0.56	0.64	0.80	1.0	1.12	1.20	1.29	1.45	1.61

Please use the following equation to calculate the leaving air temperature and the difference between entering water temperature and leaving water temperature.

$$\begin{aligned}
 \text{LAT} &= \text{EAT} + \left[\frac{KW \times 2988}{M^3/H \text{ (Air volume)}} \right] & \text{WTD} &= \text{EWT} - \text{LWT} = \left[\frac{KW}{4.19 \times L/S \text{ (Water volume)}} \right] \\
 \text{Outlet air} & \text{Inlet air} & \text{Difference between inlet} & \text{Inlet water} & \text{Outlet water} \\
 \text{temperature} & \text{temperature} & \text{water and outlet water} & \text{temperature} & \text{temperature}
 \end{aligned}$$

Dimensional Data VariTrane Single-Duct

Dimension for Single Duct with Hot Water Coil

Air Valve	Overall dimension (mm)					Air outlet dimension	
	L	H	W	D	Z	A (h)	B (w)
	05	292	211	244	127	70	203
06	292	211	244	127	70	203	254
08	279	262	269	140	57	254	279
10	305	313	345	127	70	305	356
12	330	364	422	114	83	356	432
14	356	465	472	114	83	457	483
16	381	465	574	89	108	457	584

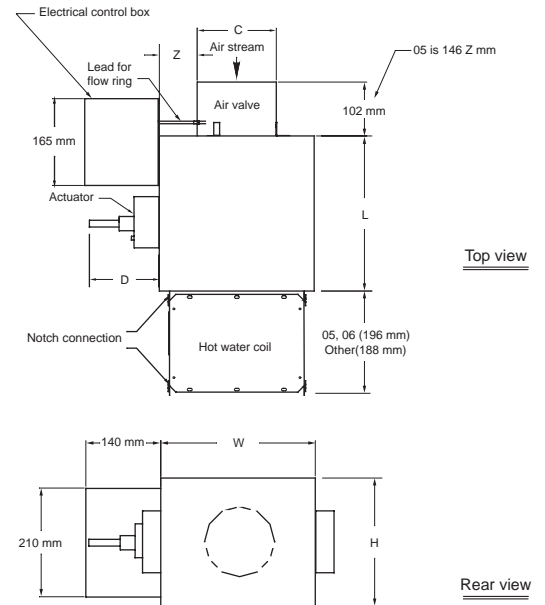
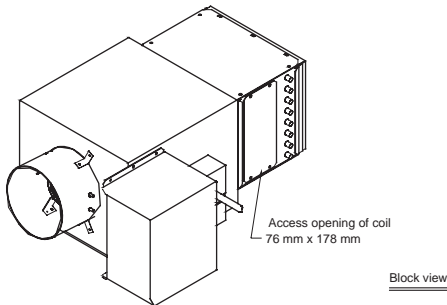

Air Valve	Dimension of coil (mm)								
		1 Row					with coil header	2 Row	
		A	B	C	D	W		A	B
05	without coil header	178	17	13	203	254	158	211	
06	without coil header	178	17	13	203	254	158	211	
08	without coil header	229	22	11	254	279	210	257	
10	without coil header	279	22	11	203	356	260	308	
12	with coil header	248	64	53	356	432	311	359	
14	with coil header	400	38	27	457	482	413	460	
16	with coil header	400	38	27	457	584	413	460	

Note: Outer diameter of coil connection for without coil head is 10mm; and Outer diameter of coil for with coil head is 10mm

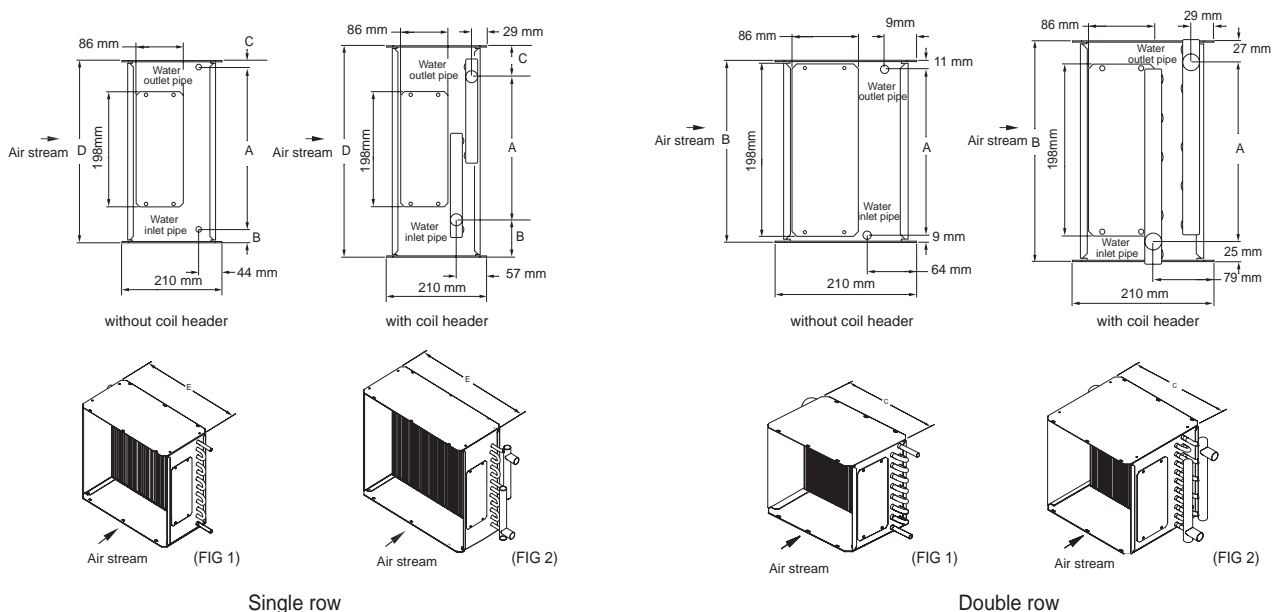

Dimensional Data VariTrane Single-Duct

Dimension for Single Duct with Electric Heating

Air Valve	Overall dimension (mm)				Air outlet dimension	
	L	H	W	D	A (h)	B (w)
05	1156	241	406	140	203	254
06	1156	241	406	140	203	254
08	1105	292	532	140	254	279
10	1105	343	508	127	305	356
12	1105	394	584	114	356	432
14	1105	495	635	114	457	483
16	1105	495	737	89	457	584

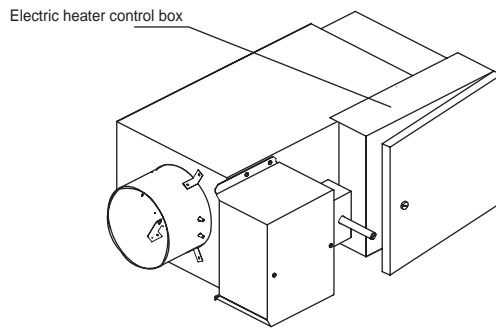

Block view

Electric Heater (kW)

Model	Heating Stages	220V	380V
05	1	1/2/3	2
	2	-	-
	3	-	-
06	1	1/2/3/4	4
	2	-	-
	3	-	-
08	1	1/2/3/4	1/2/4
	2	6/7	6
	3	-	7
10	1	1/2/3/4	1/2/4
	2	6/8	6/8
	3	9	10
12	1	1/2/3/4	1/2/4
	2	6/8	6/8/1
	3	9	12/16
14	1	1/2/3/4	2/4/6
	2	6/8	8/10/12
	3	9	16/18/22
16	1	1/2/3/4	2/4/6
	2	6/8	8/10/12/16
	3	9	18/22/26/30

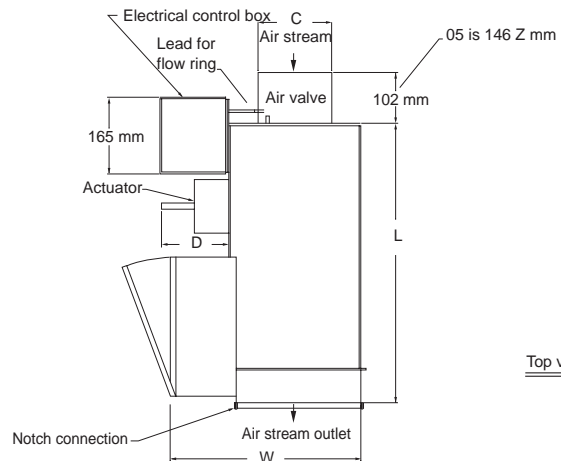

Top view

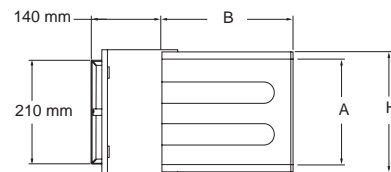

Rear view

Left

Performance Data VariTrane Series Fan-Powered

Performance Data

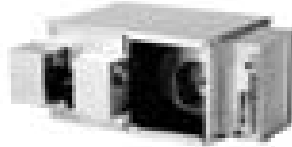

VSCT Series Fan-powered terminal device for cooling only

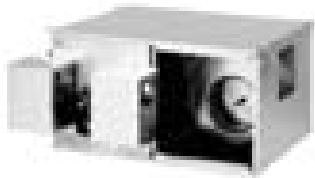

VSWT Series Fan-Powered terminal device with hot water coil



VSET Series Fan-Powered terminal device with Electric heating

Air Valve	Inlet diameter (mm)	Fan model	Air volume of fan m ³ /h	Air volume range for primary air m ³ /h	Overall dimension mm (L x W x H)	Weight (kg)
05	127	02SQ	920	595	994x699x394	35
06	152	02SQ	920	850	994x699x394	35
		03SQ	1580	850	1146x750x445	39
08	203	02SQ	920	920	994x699x394	35
		03SQ	1580	1530	1146x750x445	39
		04SQ	2180	1530	1146x750x445	39
10	254	02SQ	920	920	994x699x394	35
		03SQ	1580	1580	1146x750x445	39
		04SQ	2180	2180	1146x750x445	39
		05SQ	2660	2380	1146x902x445	45
		06SQ	3700	2380	1146x902x546	53
12	305	07SQ	4180	2380	1146x902x546	57
		03SQ	1580	1580	1146x750x445	39
		04SQ	2180	2180	1146x750x445	39
		05SQ	2660	2660	1146x902x445	45
		06SQ	3700	3400	1146x902x546	53
14	356	07SQ	4180	3400	1146x902x546	57
		04SQ	2180	2180	1146x750x445	39
		05SQ	2660	2660	1146x902x445	45
		06SQ	3700	3700	1146x902x546	53
16	406	07SQ	4180	4180	1146x902x546	57
		06SQ	3700	3700	1146x902x546	53
		07SQ	4180	4180	1146x902x546	57

Hot Water Coil (kW)

Fan model	Coil Rows	Water volume (L/s)	Water pressure drop (kPa)	Air volume (m ³ /h)									
				255	340	425	510	595	680	765	850	920	
02SQ	1 Row	0.06	1.59	2.68	3.03	3.32	3.58	3.80	4.01	4.20	4.38	4.52	
		0.13	5.52	2.91	3.34	3.70	4.02	4.32	4.59	4.84	5.08	5.27	
		0.19	11.51	3.00	3.46	3.85	4.20	4.52	4.82	5.10	5.37	5.58	
		0.25	19.45	3.05	3.52	3.93	4.30	4.63	4.95	5.25	5.53	5.75	
		0.32	29.27	3.08	3.56	3.98	4.36	4.71	5.03	5.34	5.63	5.86	
	2 Row	0.06	3.00	3.69	4.46	5.10	5.63	6.08	6.46	6.80	7.09	7.30	
		0.13	10.21	3.93	4.86	5.67	6.37	6.99	7.54	8.03	8.47	8.81	
		0.19	21.07	4.02	5.01	5.87	6.64	7.33	7.95	8.51	9.02	9.41	
		0.25	35.33	4.06	5.08	5.98	6.78	7.51	8.16	8.76	9.31	9.73	
		0.32	52.84	4.09	5.12	6.04	6.87	7.62	8.30	8.92	9.50	9.94	



Performance Data VariTrane Series Fan-Powered

Hot Water Coil (kW) - contiune

Fan model	Coil Rows	Water volume (L/s)	Water pressure drop (kPa)	Air volume (m³/h)								
				340	510	680	934	1189	1444	1580	1954	2180
03SQ /04SQ	1 Row	0.13	3.02	4.40	5.33	6.04	6.91	7.62	8.23	8.53	9.29	9.70
		0.19	6.56	4.60	5.64	6.45	7.45	8.29	9.03	9.39	10.30	10.79
		0.25	11.39	4.71	5.80	6.67	7.75	8.67	9.49	9.89	10.91	11.47
		0.32	17.49	4.77	5.91	6.81	7.94	8.92	9.79	10.21	11.31	11.92
		0.38	24.86	4.82	5.98	6.91	8.08	9.09	10.00	10.44	11.60	12.24
		0.44	33.49	4.85	6.03	6.98	8.18	9.22	10.16	10.62	11.81	12.48
		0.50	43.36	4.88	6.08	7.04	8.26	9.32	10.28	10.75	11.98	12.66
	0.57	54.46	4.90	6.11	7.08	8.32	9.40	10.38	10.86	12.12	12.81	
	0.63	66.80	4.92	6.13	7.12	8.37	9.47	10.46	10.94	12.22	12.94	
	2 Row	0.13	4.22	5.55	7.50	9.07	10.90	12.31	13.42	13.90	15.06	15.61
		0.19	8.99	5.70	7.83	9.61	11.78	13.52	14.94	15.57	17.13	17.90
		0.25	15.41	5.78	8.00	9.89	12.25	14.18	15.79	16.52	18.33	19.24
		0.32	23.45	5.83	8.10	10.06	12.54	14.60	16.33	17.13	19.12	20.12
		0.38	33.07	5.86	8.17	10.18	12.74	14.88	16.71	17.55	19.67	20.75
0.44		44.26	5.88	8.22	10.26	12.88	15.09	16.99	17.86	20.07	21.21	
0.50		57.00	5.90	8.26	10.33	12.99	15.25	17.20	18.10	20.39	21.57	

Fan model	Coil Rows	Water volume (L/s)	Water pressure drop (kPa)	Air volume (m³/h)							
				595	850	1104	1359	1699	2039	2379	2660
05SQ	1 Row	0.13	3.22	6.35	7.40	8.23	8.94	9.76	10.49	11.12	11.59
		0.19	6.95	6.75	7.95	8.94	9.78	10.77	11.64	12.42	13.03
		0.25	12.04	6.96	8.26	9.33	10.27	11.37	12.34	13.23	13.90
		0.32	18.46	7.10	8.46	9.59	10.58	11.76	12.81	13.77	14.50
		0.38	26.20	7.19	8.60	9.77	10.80	12.03	13.14	14.15	14.93
		0.44	35.23	7.26	8.70	9.90	10.97	12.24	13.39	14.44	15.26
		0.50	45.57	7.32	8.78	10.01	11.09	12.40	13.58	14.67	15.51
	2 Row	0.13	4.16	8.78	11.05	12.78	14.16	15.58	16.69	17.57	18.17
		0.19	8.85	9.20	11.83	13.94	15.68	17.57	19.10	20.35	21.23
		0.25	15.17	9.42	12.23	14.56	16.52	18.69	20.48	21.99	23.06
		0.32	23.09	9.55	12.48	14.95	17.04	19.41	21.38	23.07	24.28
		0.38	32.57	9.63	12.65	15.21	17.40	19.90	22.01	23.83	25.14
		0.44	43.60	9.70	12.77	15.39	17.67	20.26	22.48	24.39	25.78
		0.50	56.16	9.74	12.86	15.54	17.87	20.54	22.83	24.82	26.27

Fan model	Coil Rows	Water volume (L/s)	Water pressure drop (kPa)	Air volume (m³/h)									
				1189	1529	1869	2209	2549	2888	3228	3568	4060	4180
06SQ /07SQ	1 Row	0.13	4.10	9.15	10.11	10.98	11.74	12.41	13.00	13.54	14.03	14.67	14.82
		0.19	8.46	9.91	11.07	12.07	12.97	13.80	14.58	15.29	15.94	16.81	17.01
		0.25	14.22	10.34	11.61	12.73	13.73	14.66	15.51	16.30	17.07	18.08	18.32
		0.32	21.30	10.61	11.96	13.15	14.23	15.23	16.15	17.02	17.83	18.93	19.19
		0.38	29.68	10.80	12.20	13.45	14.59	15.64	16.62	17.54	18.40	19.57	19.84
		0.44	39.08	10.98	12.33	13.61	14.80	15.91	16.95	17.92	18.93	20.19	20.47
	2 Row	0.13	7.71	14.01	15.83	17.23	18.33	19.23	19.97	20.59	21.11	21.75	21.89
		0.19	15.74	15.27	17.61	19.49	21.04	22.33	23.43	24.38	25.20	26.21	26.44
		0.25	26.24	15.94	18.58	20.75	22.58	24.14	25.49	26.67	27.71	29.00	29.29
		0.32	39.08	16.34	19.18	21.55	23.58	25.32	26.85	28.19	29.38	30.88	31.23
		0.38	54.19	16.62	19.59	22.11	24.27	26.15	27.80	29.27	30.58	32.24	32.62
		0.44	70.00	16.88	20.11	22.73	25.00	27.00	28.80	30.40	31.90	33.60	34.00
		0.50	86.00	17.12	20.71	23.41	25.80	28.00	29.90	31.60	33.30	35.20	35.60
		0.57	102.00	17.35	21.31	24.21	26.70	29.10	31.10	32.90	34.80	36.80	37.20

Note: Leaving water temperature of hot water coil LWT should not exceed 60°C.

Heating capacity is based on entering air temperature of 21°C and entering water temperature of 82°C. Refer to correction factors different entering conditions, actual heating capacity = data in the table above x temperature correction factor

Entering water temperature minus entering air temperature EWT-EAT	22	27	33	38	44	50	55	61	67	72
Correction factor	0.355	0.446	0.537	0.629	0.722	0.814	0.907	1.000	1.093	1.187

By using the following equation, Leaving air temperature LAT and difference between entering water temperature and leaving water WTD temperature can be calculated.

$$LAT = EAT + \left[\frac{KW \times 2988}{M^3/H (Air \ volume)} \right] \quad WTD = EWT - LWT = \left[\frac{KW}{4.19 \times L/S (Water \ volume)} \right]$$

Outlet air temperature
Inlet air temperature
Difference between inlet water and outlet water
Entering water temperature
Leaving water temperature

Performance Data

VariTrane Series Fan-Powered

Series Fan Curve

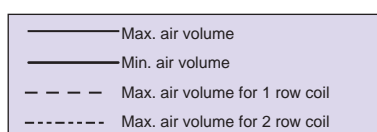
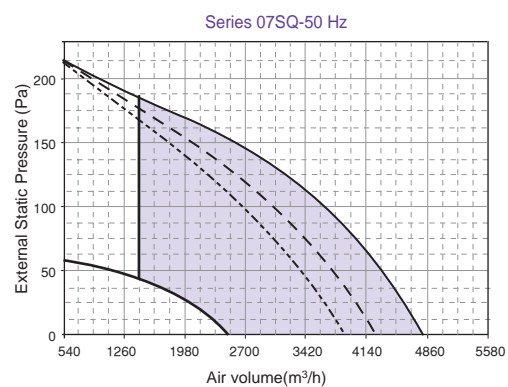
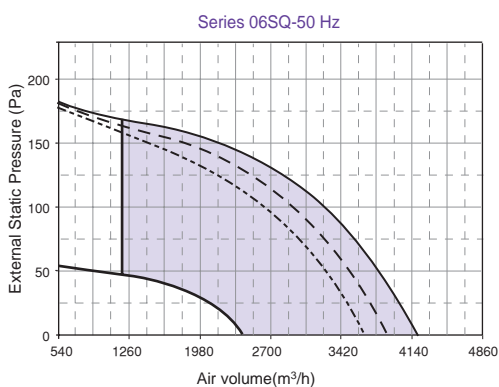
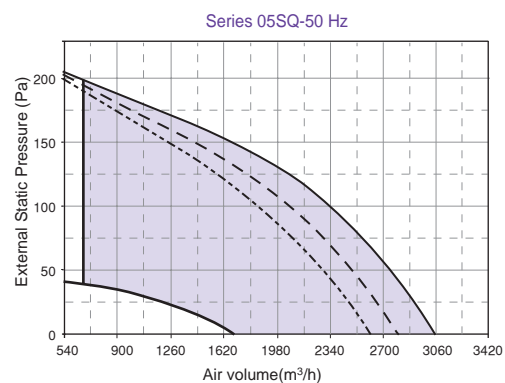
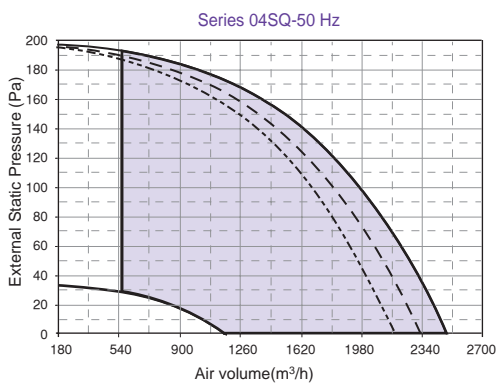
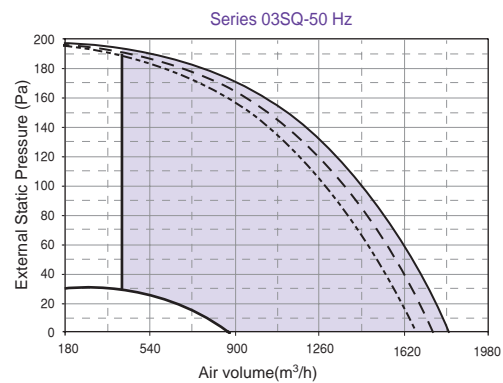
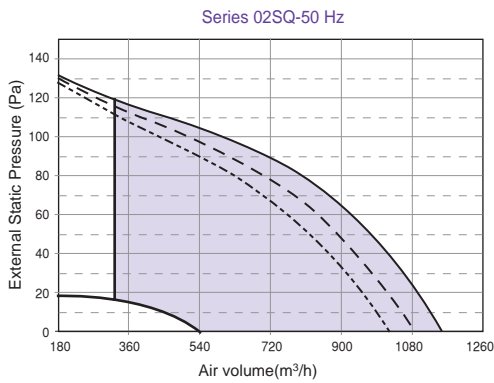

Dimensional Data VariTrane Series Fan-Powered

Dimension for Series Fan Powered with Hot Water Coil

Fan model	Overall dimension (mm)							
	L	H	W	Air outlet dimension		C	D	E
				A (h)	B (w)			
02SQ	864	394	559	305	356	127	17	171
03SQ	1016	445	610	483	406	64	19	273
04SQ	1016	445	610	483	406	64	19	273
05SQ	1016	445	762	610	406	76	19	273
06SQ	1016	546	762	610	457	76	42	171
07SQ	1016	546	762	610	457	76	42	171

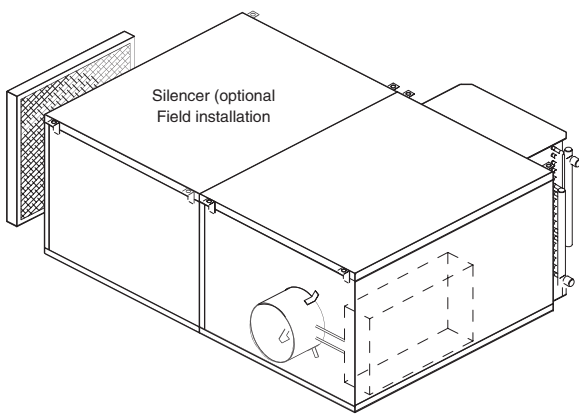

Actuator, controller and electrical controls of the fan

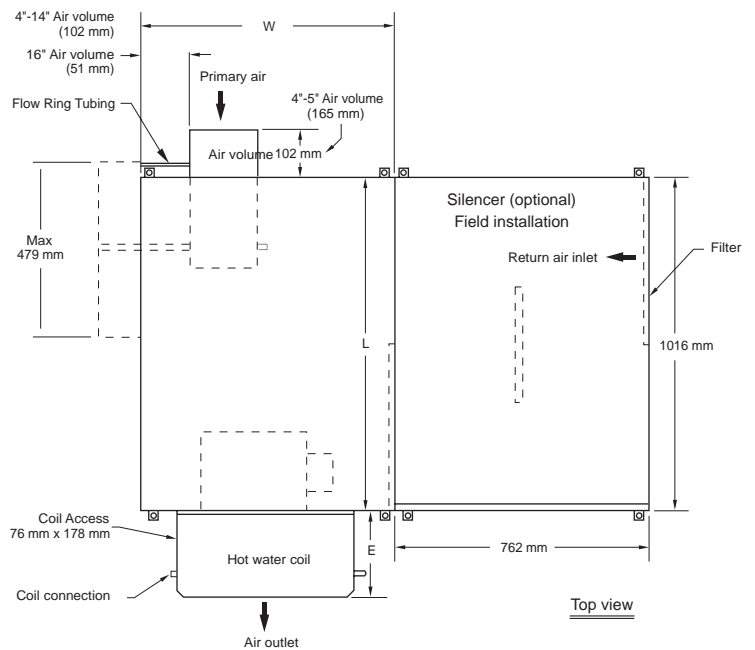

Top view

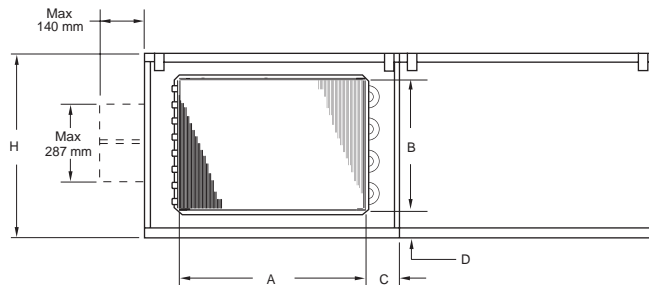

Rear view

Fan model	Filter Size (standard configuration)
02SQ	356 mm x 356 mm x 15 mm
03SQ 04SQ 05SQ	406 mm x 508 mm x 15 mm
06SQ 07SQ	508 mm x 508 mm x 15 mm

Dimensional Data

VariTrane Series Fan-Powered

Dimension for Hot Water Coil

Fan model	Dimension of coil (mm)									
	1 Row					2 Row				
	A	B	L	H	W	A	B	L	H	W
02SQ	248	51	310	356	171	260	51	310	356	171
03SQ	349	51	533	406	273	349	51	533	406	273
04SQ	349	51	533	406	273	349	51	533	406	273
05SQ	349	51	610	406	273	349	51	610	406	273
06SQ	400	25	610	457	171	400	25	610	457	171
07SQ	400	25	610	457	171	400	25	610	457	171

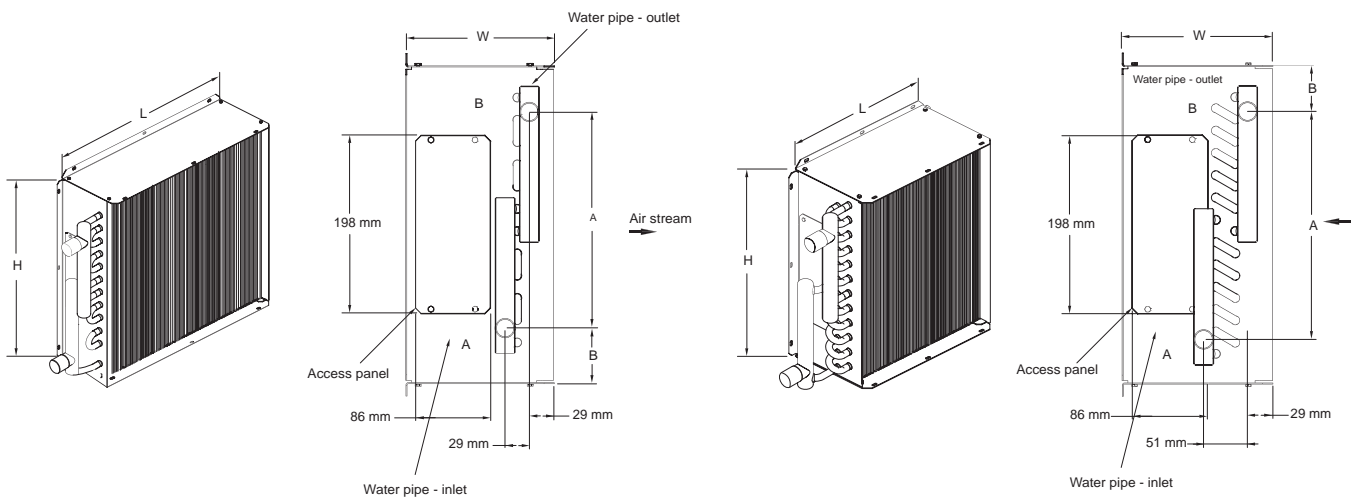

Dimensional Data VariTrane Series Fan-Powered

Dimension for Series Fan-Powered with Electric Heating

Fan model	Overall dimension (mm)							
	L	H	W	Air outlet dimension		C	D	E
				A (h)	B (w)			
02SQ	864	394	559	305	254	127	457	470
03SQ	1016	445	610	305	305	102	457	470
04SQ	1016	445	610	406	305	102	559	470
05SQ	1016	445	762	406	305	254	559	470
06SQ	1016	546	762	483	356	140	635	432
07SQ	1016	546	762	483	356	140	635	432

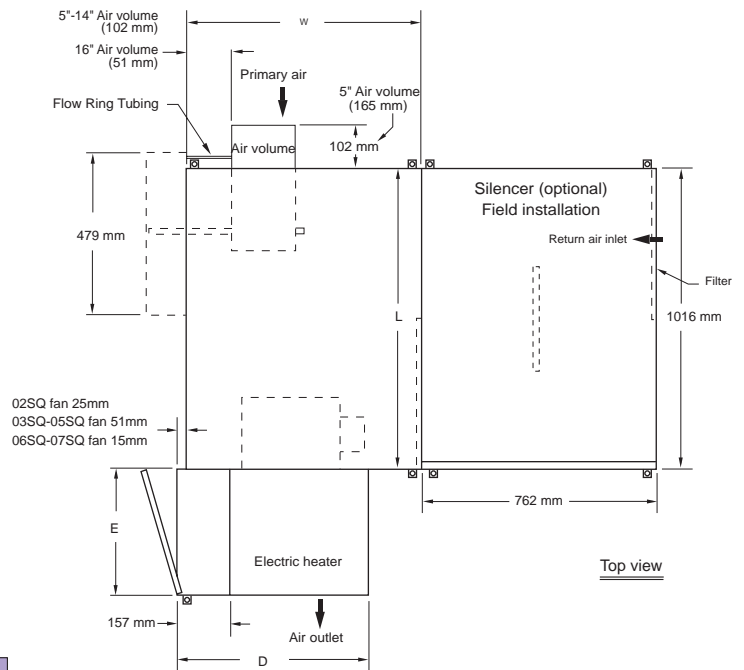
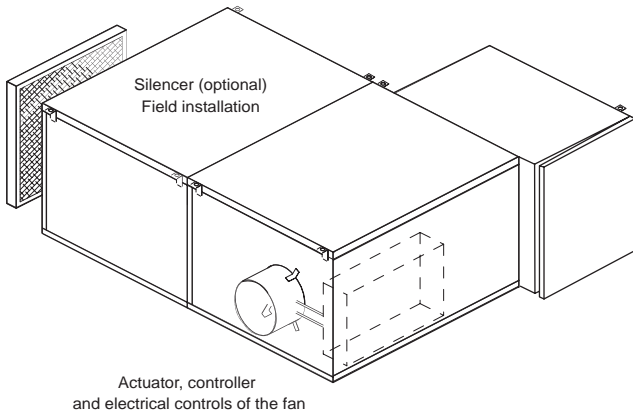

Electric Heater (kW)

Model	Heating Stages	220V	380V
		02SQ	1
	2	6	6
03SQ	1	1/2/3/4	1/2/3/4
	2	6/8	6/8/10
04SQ	1	1/2/3/4	1/2/3/4
	2	6/8	8/10/12/14
05SQ	1	1/2/3/4	2/4/6/8
	2	6/8	10/12/14/16
06SQ	1	1/2/3/4	2/4/6/8
	2	6/8	10/12/14/16/20
07SQ	1	1/2/3/4	2/4/6/8
	2	6/8	10/12/16/20

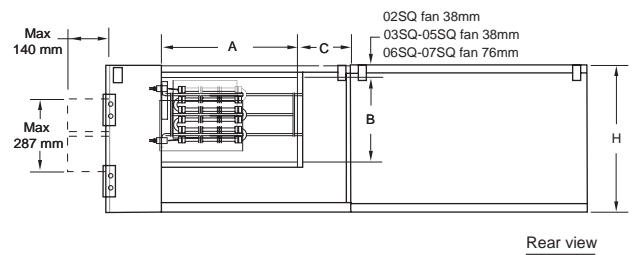

Fan model	Filter Size (standard configuration)
02SQ	356 mm x 356 mm x 15 mm
03SQ 04SQ 05SQ	406 mm x 508 mm x 15 mm
06SQ 07SQ	508 mm x 508 mm x 15 mm

Performance Data

VariTrane Parallel Fan-Powered

Performance Data

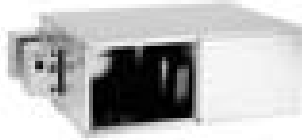

VPCT Parallel Fan-Powered terminal device for cooling only

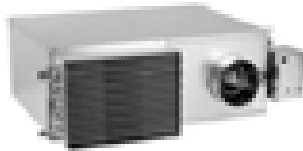

VPWT Parallel Fan-Powered terminal device with hot water coil

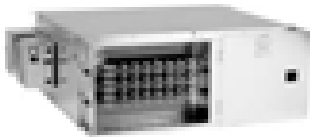

VPET Parallel Fan-Powered terminal device with electric heating

Air valve	Inlet diameter (mm)	Fan model	Air volume of fan m ³ /h	Air volume range for primary air m ³ /h	Overall dimension mm (L x W x H)	Weight (kg)
05	127	02SQ	320	68-595	864x1156x394	35
06	152	02SQ	320	101-850	864x1156x394	35
		03SQ	1470	101-850	927x1156x445	43
08	203	02SQ	320	180-1530	864x1156x394	35
		03SQ	1470	180-1530	927x1156x445	43
		04SQ	1830	180-1530	927x1156x445	44
10	254	02SQ	320	277-2380	64x1156x394	35
		03SQ	1470	277-2380	927x1156x445	43
		04SQ	1830	277-2380	927x1156x445	44
		05SQ	1900	277-2380	927x1156x445	50
		06SQ	2300	277-2380	1118x1156x546	53
12	305	07SQ	2550	277-2380	1118x1156x546	57
		03SQ	1470	400-3400	927x1156x445	43
		04SQ	1830	400-3400	927x1156x445	44
		05SQ	1900	400-3400	927x1156x445	50
		06SQ	2300	400-3400	1118x1156x546	53
14	356	07SQ	2550	400-3400	1118x1156x546	57
		04SQ	1830	544-5100	927x1156x445	44
		05SQ	1900	544-5100	927x1156x445	50
		06SQ	2300	544-5100	1118x1156x546	53
16	406	07SQ	2550	544-5100	1118x1156x546	57
		06SQ	2300	713-6800	1118x1156x546	53
		07SQ	2550	713-6800	1118x1156x546	57



Performance Data VariTrane Parallel Fan-Powered

Hot Water Coil Performance Data (kW)

Fan model	Coil Rows	Water volume (L/s)	Water pressure drop (kPa)	Air volume (m³/h)										
				170	255	340	425	510	595	680	765	850	934	1020
02SQ	1 Row	0.03	0.66	2.41	2.67	3.24	3.51	3.73	3.92	4.07	4.20	4.32	4.42	4.51
		0.06	2.26	2.69	3.37	3.85	4.24	4.56	4.84	5.09	5.32	5.55	5.76	5.95
		0.13	7.91	2.87	3.66	4.26	4.74	5.16	5.53	5.87	6.18	6.47	6.75	7.00
		0.19	16.57	2.93	3.77	4.41	4.93	5.39	5.80	6.18	6.52	6.85	7.16	7.46
		0.25	28.08	2.97	3.83	4.49	5.04	5.52	5.95	6.34	6.71	7.06	7.39	7.71
	0.32	42.34	2.99	3.87	4.54	5.10	5.59	6.04	6.45	6.83	7.19	7.53	7.86	
	2 Row	0.06	3.89	2.92	4.05	5.00	5.80	6.49	7.07	7.58	8.02	8.40	8.74	9.05
		0.13	13.19	3.02	4.27	5.39	6.38	7.27	8.08	8.80	9.46	10.06	10.60	11.11
		0.19	27.13	3.05	4.35	5.52	6.58	7.55	8.43	9.24	9.99	10.68	11.32	11.92
		0.25	45.38	3.06	4.38	5.58	6.68	7.69	8.62	9.47	10.27	11.01	11.70	12.35
0.32		67.73	3.07	4.40	5.62	6.74	7.77	8.73	9.61	10.44	11.21	11.93	12.61	

Fan model	Coil Rows	Water volume (L/s)	Water pressure drop (kPa)	Air volume (m³/h)										
				255	510	765	1019	1274	1529	1784	2039	2294	2549	2804
03SQ /04SQ /05SQ	1 Row	0.06	0.82	3.49	4.72	5.45	6.03	6.49	6.86	7.18	7.45	7.69	7.90	8.09
		0.13	3.06	3.85	5.46	6.51	7.33	8.02	8.62	9.17	9.67	10.12	10.53	10.91
		0.19	6.63	3.99	5.77	6.97	7.93	8.75	9.48	10.14	10.74	11.29	11.81	12.31
		0.25	11.51	4.07	5.94	7.22	8.27	9.17	9.97	10.71	11.38	12.01	12.60	13.15
		0.32	17.68	4.11	6.05	7.39	8.48	9.44	10.30	11.08	11.81	12.49	13.13	13.73
		0.38	25.13	4.15	6.12	7.50	8.64	9.63	10.53	11.35	12.12	12.84	13.51	14.15
		0.44	33.83	4.17	6.18	7.58	8.75	9.77	10.70	11.55	12.35	13.09	13.80	14.47
		0.50	43.79	4.19	6.22	7.65	8.83	9.88	10.83	11.71	12.52	13.29	14.02	14.71
		0.57	55.00	4.20	6.25	7.70	8.90	9.97	10.93	11.83	12.67	13.46	14.20	14.91
		0.63	67.45	4.21	6.28	7.74	8.96	10.04	11.02	11.93	12.78	13.59	14.35	15.08
/04SQ /05SQ	2 Row	0.06	1.06	4.10	6.52	8.01	9.06	9.78	10.31	10.70	11.02	11.27	11.48	11.65
		0.13	3.83	4.42	7.58	9.88	11.60	12.93	14.00	14.87	15.59	16.20	16.73	17.18
		0.19	8.20	4.50	7.91	10.53	12.60	14.27	15.65	16.81	17.80	18.66	19.40	20.07
		0.25	14.11	4.54	8.08	10.88	13.14	15.01	16.58	17.92	19.09	20.11	21.01	21.81
		0.32	21.52	4.57	8.18	11.09	13.47	15.47	17.17	18.64	19.92	21.06	22.07	22.97
		0.38	30.42	4.58	8.25	11.23	13.70	15.79	17.58	19.14	20.51	21.73	22.82	23.81
		0.44	40.78	4.60	8.30	11.33	13.87	16.02	17.88	19.51	20.95	22.23	23.39	24.43
		0.50	52.59	4.61	8.33	11.41	13.99	16.20	18.12	19.80	21.29	22.62	23.82	24.91
		0.57	65.84	4.61	8.36	11.47	14.09	16.34	18.30	20.02	21.56	22.93	24.17	25.30
		0.63	80.52	4.62	8.39	11.52	14.17	16.45	18.45	20.21	21.77	23.18	24.46	25.62

Fan model	Coil Rows	Water volume (L/s)	Water pressure drop (kPa)	Air volume (m³/h)												
				1529	1699	1869	2039	2209	2379	2549	2718	2888	3058	3230		
06SQ /07SQ	1 Row	0.03	0.33	5.18	5.27	5.35	5.42	5.48	5.54	5.59	5.64	5.68	5.72	5.76		
		0.06	1.09	7.74	7.98	8.20	8.41	8.59	8.76	8.91	9.06	9.20	9.32	9.44		
		0.13	3.71	9.43	9.85	10.24	10.60	10.94	11.26	11.57	11.86	12.13	12.39	12.64		
		0.19	7.68	10.29	10.77	11.23	11.66	12.06	12.46	12.84	13.21	13.56	13.90	14.22		
		0.25	12.92	10.78	11.31	11.82	12.30	12.75	13.19	13.61	14.01	14.40	14.78	15.15		
		0.32	19.39	11.10	11.66	12.20	12.71	13.20	13.67	14.13	14.57	14.99	15.40	15.79		
		0.38	27.04	11.32	11.91	12.47	13.01	13.52	14.02	14.50	14.96	15.40	15.84	16.26		
		0.44	35.84	11.48	12.09	12.67	13.23	13.76	14.27	14.77	15.25	15.72	16.17	16.61		
		/07SQ	2 Row	0.06	2.02	11.26	11.57	11.84	12.06	12.26	12.43	12.58	12.71	12.83	12.93	13.03
				0.13	6.70	14.96	15.64	16.25	16.80	17.28	17.72	18.12	18.48	18.82	19.12	19.40
0.19	13.65			16.60	17.51	18.33	19.07	19.74	20.36	20.93	21.45	21.94	22.39	22.81		
0.25	22.70			17.51	18.54	19.49	20.36	21.15	21.89	22.57	23.20	23.80	24.35	24.87		
0.32	33.76			18.07	19.20	20.23	21.18	22.06	22.88	23.64	24.35	25.02	25.64	26.23		
0.38	46.74			18.46	19.65	20.75	21.76	22.70	23.58	24.39	25.16	25.88	26.56	27.20		
0.44	61.61	18.75	19.98	21.12	22.18	23.17	24.09	24.95	25.76	26.52	27.24	27.93				

Note: Leaving water temperature of hot water coil LWT should not exceed 60°C.

Heating capacity is based on entering air temperature of 21°C and entering water temperature of 82°C. Refer to correction factors for different entering conditions, actual heating capacity = data in the table above x temperature correction factor

In case the data required by customer exceeds the range in the table, please contact our technical support.

Entering water temperature minus entering air temperature EWT-EAT	22	27	33	39	44	50	55	61	67	72
Correction factor	0.355	0.446	0.537	0.629	0.722	0.814	0.907	1.000	1.093	1.187

By using the following equation, Leaving air temperature LAT and difference between entering water temperature and outlet water temperature WTD can be calculated.

$$LAT = EAT + \left[\frac{KW \times 2988}{M^3/H \text{ (Air volume)}} \right] \quad WTD = EWT - LWT = \left[\frac{KW}{4.19 \times L/S \text{ (Water volume)}} \right]$$

Outlet air temperature
Inlet air temperature
Difference between inlet water and outlet water
Entering water temperature
Leaving water temperature

Performance Data

VariTrane Parallel Fan-Powered

Parallel Fan Curve

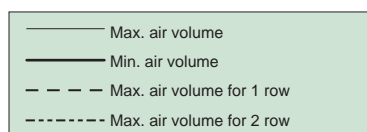
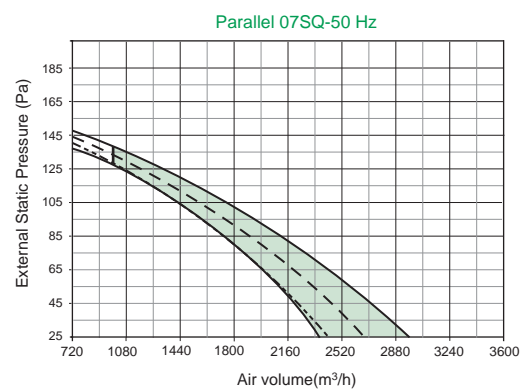
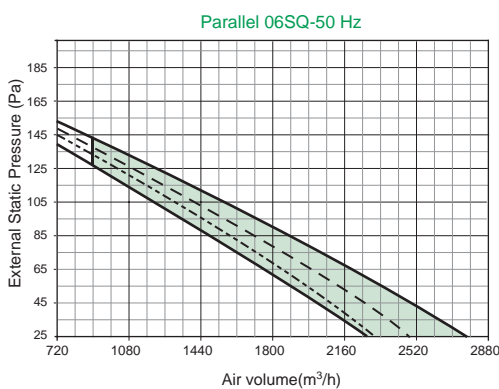
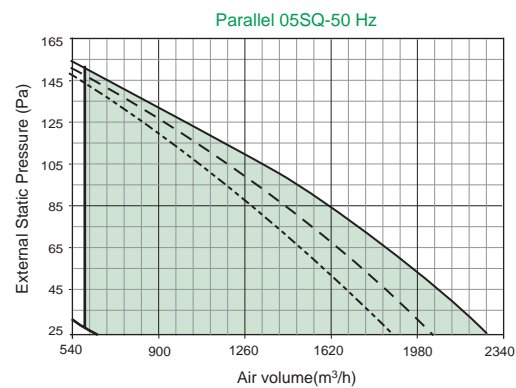
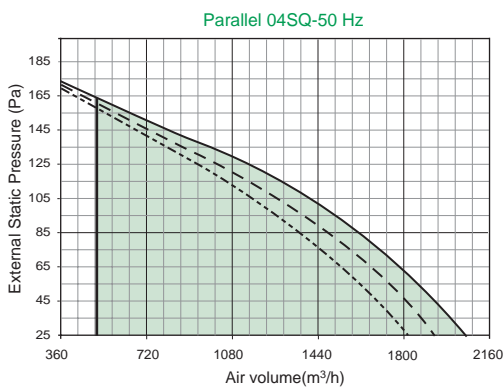
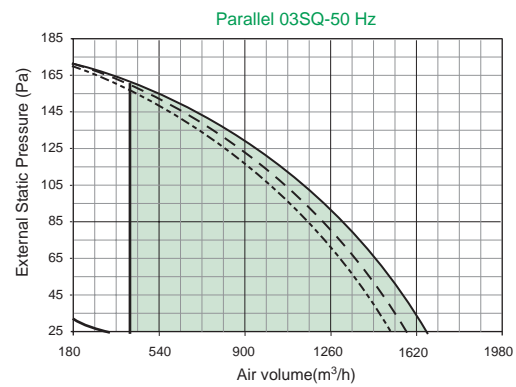
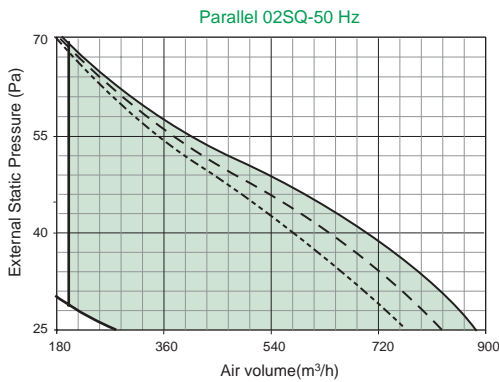

Dimensional Data

VariTrane Parallel Fan-Powered

Dimension for Parallel Fan-Powered with Hot Water Coil – Coil at Return Air Inlet

Fan model	Overall dimension (mm)			Air outlet dimension	
	L	H	W	A (h)	B (w)
02SQ	762	394	1016	489	356
03SQ	826	445	1016	489	406
04SQ	826	445	1016	489	406
05SQ	826	445	1016	489	406
06SQ	1016	546	1016	489	508
07SQ	1016	546	1016	489	508

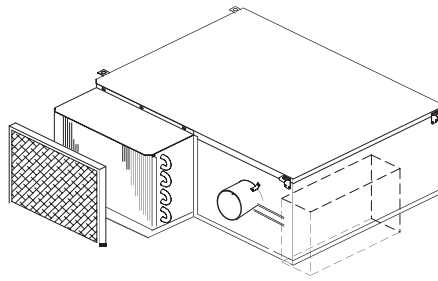

Actuator, controller and electrical controls of the fan

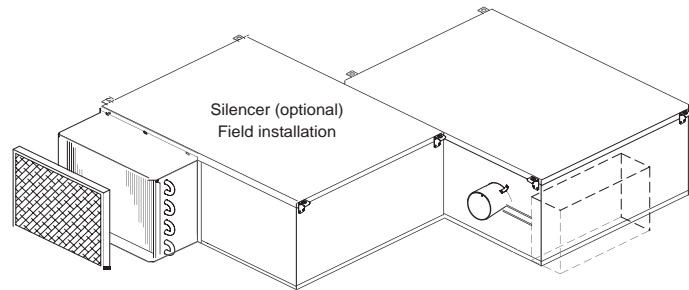

Actuator, controller and electrical controls of the fan

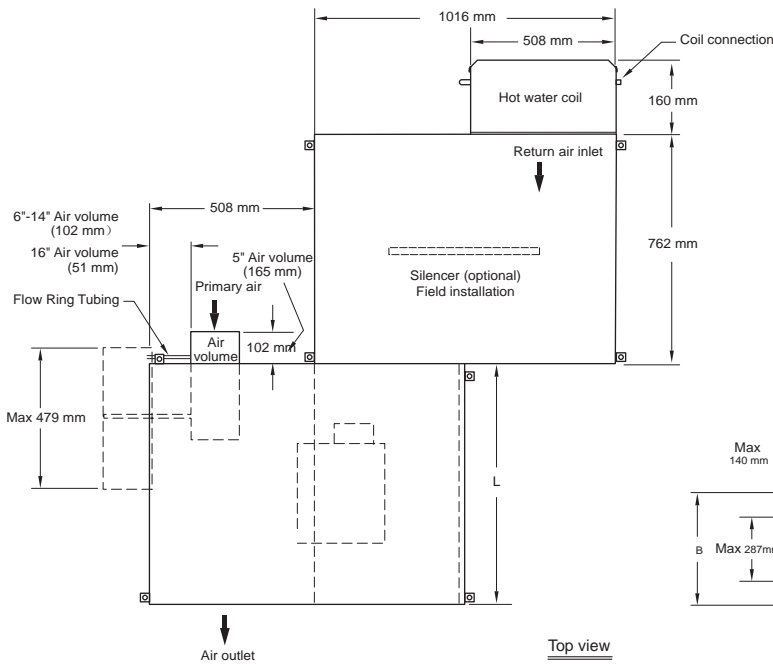

Top view

Fan model	Filter Size (standard configuration)
02SQ	356 mm x 508 mm x 15 mm
03SQ 04SQ 05SQ	406 mm x 508 mm x 15 mm
06SQ 07SQ	508 mm x 508 mm x 15 mm

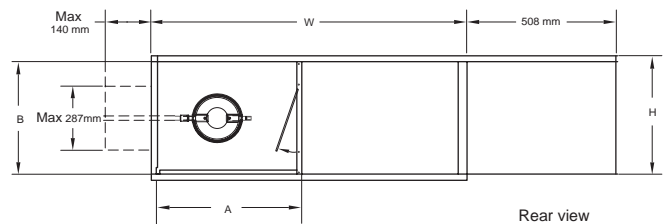

Rear view

Dimensional Data

VariTrane Parallel Fan-Powered

Dimension for Parallel Fan-Powered Hot Water Coil – Coil at Air Outlet

Fan model	Overall dimension (mm)			Air outlet dimension	
	L	H	W	A (h)	B (w)
02SQ	762	394	1016	508	356
03SQ	826	445	1016	508	406
04SQ	826	445	1016	508	406
05SQ	826	445	1016	508	406
06SQ	1016	546	1016	508	508
07SQ	1016	546	1016	508	508

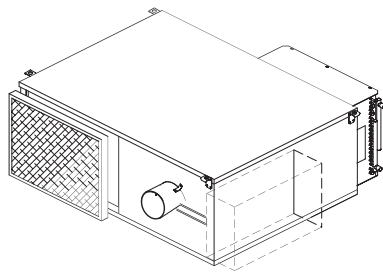

Actuator, controller and electrical controls of the fan

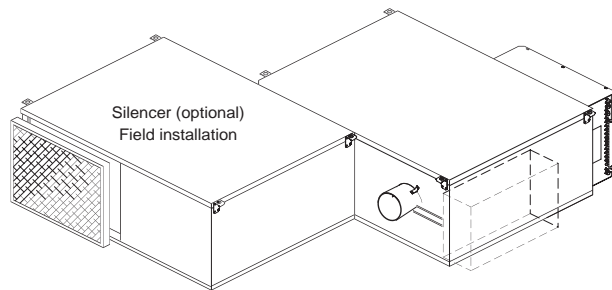

Actuator, controller and electrical controls of the fan

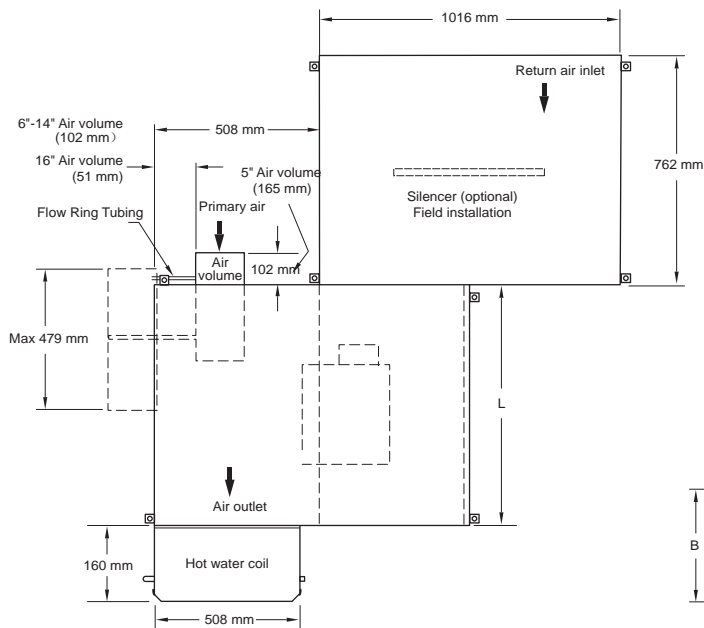

Top view

Fan model	Filter size (standard configuration)
02SQ	356 mm x 508 mm x 15 mm
03SQ 04SQ 05SQ	406 mm x 508 mm x 15 mm
06SQ 07SQ	508 mm x 508 mm x 15 mm

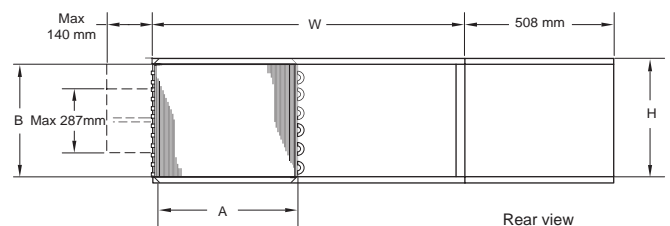

Rear view

Dimensional Data VariTrane Parallel Fan-Powered

Dimension for Hot Water Coil at Air Inlet

Fan model	Dimension of coil (mm)												
	1 Row							2 Row					
	A	B	C	D	L	H	W	A	B	C	L	H	W
02SQ	248	33	51	64	513	359	171	260	32	173	513	359	171
03SQ	349	25	25	38	508	406	160	349	25	170	508	406	160
04SQ	349	25	25	38	508	406	160	349	25	170	508	406	160
05SQ	349	25	25	38	508	406	160	349	25	170	508	406	160
06SQ	400	32	51	64	513	513	171	400	28	173	513	513	171
07SQ	400	32	51	64	513	513	171	400	28	173	513	513	171

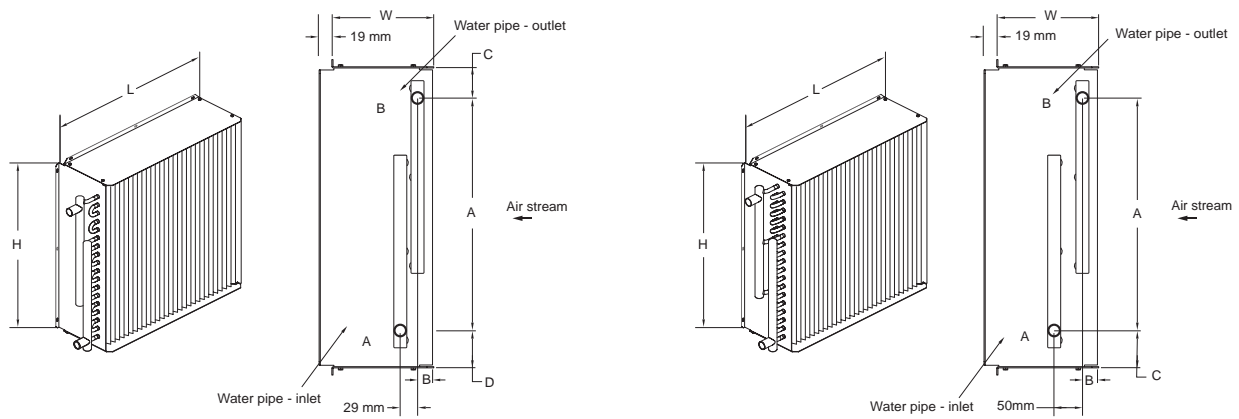

Dimension for Hot Water Coil at Air Outlet

Fan model	Dimension of coil (mm)											
	1 Row					2 Row						
	A	B	L	H	W	A	B	C	D	L	H	W
02SQ	248	41	513	359	171	248	41	173	51	513	359	171
03SQ	349	41	508	406	160	349	25	170	25	508	406	160
04SQ	349	41	508	406	160	349	25	170	25	508	406	160
05SQ	349	41	508	406	160	349	25	170	25	508	406	160
06SQ	400	41	513	513	171	400	32	173	51	513	513	171
07SQ	400	41	513	513	171	400	32	173	51	513	513	171

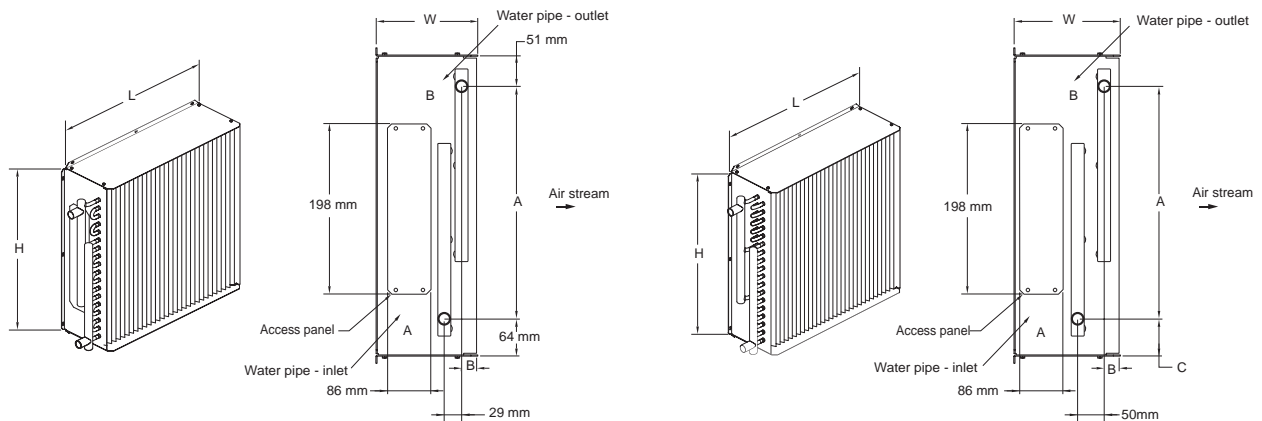

Dimensional Data VariTrane Parallel Fan-Powered

Dimension of Parallel Fan-Powered with Heater

Fan model	Overall dimension (mm)				
	L	H	W	Air outlet dimension	
				A (h)	B (w)
02SQ	762	394	1016	508	356
03SQ	826	445	1016	508	406
04SQ	826	445	1016	508	406
05SQ	826	445	1016	508	406
06SQ	1016	546	1016	508	508
07SQ	1016	546	1016	508	508

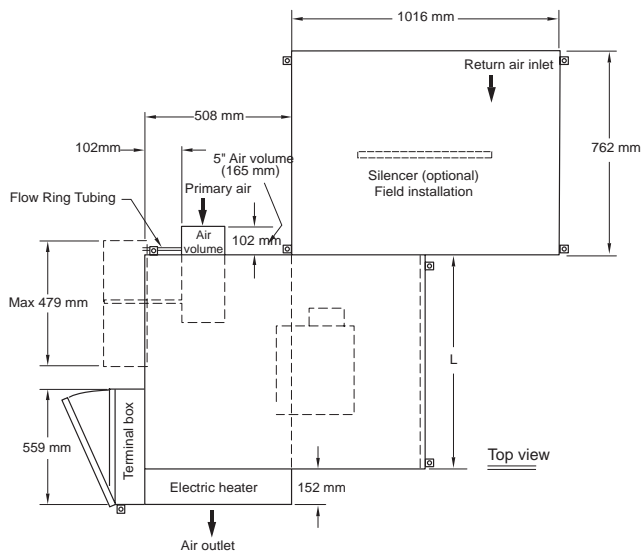
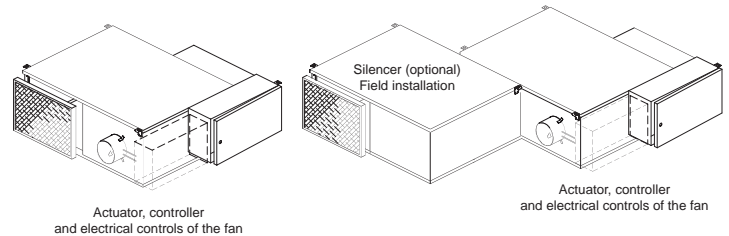

Fan model	Filter Size (standard configuration)
02SQ	356 mm x 508 mm x 15 mm
03SQ 04SQ 05SQ	406 mm x 508 mm x 15 mm
06SQ 07SQ	508 mm x 508 mm x 15 mm

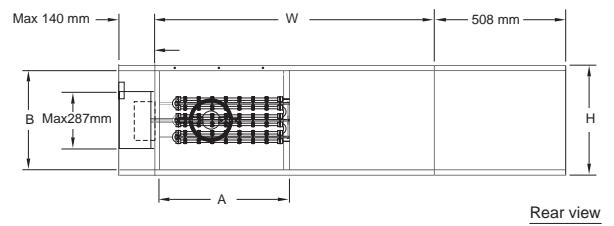

Outline Schematic of Electrical Control Box

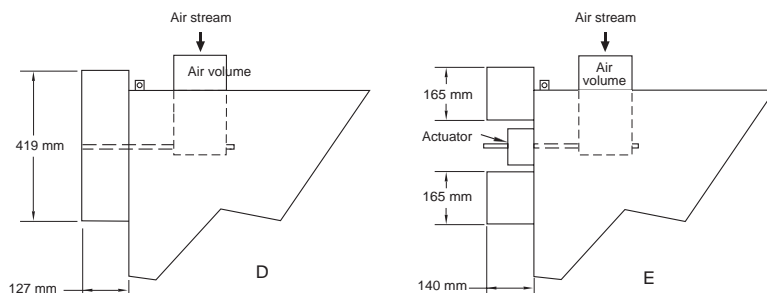

Control type		DD01-DD04	DD011-DD014	FM00
Fan model	02SQ	D	D	D
	03SQ 04SQ 05SQ	D	D	D
	06SQ 07SQ	E	D	D

Electric Heater (kW)

Model	Heating stages	220V	380V
02SQ	1	1/2/3	1/2/3
	2	-	-
03SQ	1	1/2/3/4	1/2/3/4
	2	6/8	6/8
04SQ	1	1/2/3/4	1/2/4/6
	2	6/8	8/10/12
05SQ	1	1/2/3/4	1/2/4/6
	2	6/8	8/10/12/14
06SQ	1	1/2/3/4	1/2/4/6
	2	6/8	8/10/12
07SQ	1	1/2/3/4	2/4/6/8
	2	6/8	10/12/14/16



Trane
www.trane.com

For more information, contact your local district office

Literature Order Number VAV-PRC010-EN (November 2007)

File Number PL-TD-000-VAV-PRC010-EN-1107

Supersedes New

Stocking location China

Trane has a policy of continuous product and data improvement and reserves the right to change design specific ations without notice.