

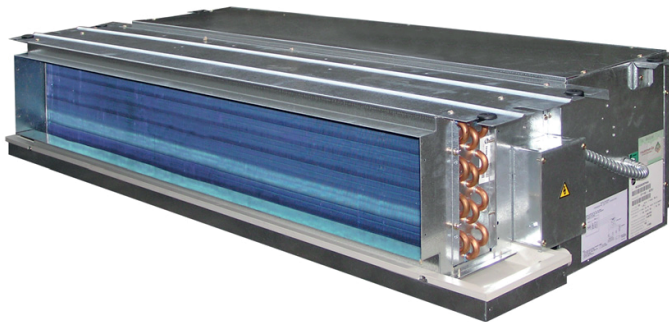

# Illusion Split System

**Split System Air Conditioning (Concealed Type)**  
**1.5 - 5 Tons - R410a - 50 Hz**



**Indoor Units**

MCDA18DB  
MCDA24DB  
MCDA30DB  
MCDA36DB  
MCDB42DB  
MCDB48DB  
MCDB60DB

**Outdoor Units**

4TTB3018AA  
4TTB3024AA  
4TTB3030AA  
4TTB3036AA  
4TTA3030AD  
4TTA3036AD  
4TTA3042AD  
4TTA3048AD  
4TTA3060AD

---

**SSA-PRC012A-EN**



# Contents

---

Features and Benefits _____	04
Nomenclature _____	07
General Data	
4TTB _____	09
4TTA _____	10
MCD _____	12
Performance Data _____	15
Fan Performance Data _____	16
Performance Data Cooling _____	20
MCD Wiring Diagram _____	25
Electrical Data _____	30
MCD Dimensional Data _____	36
Dimensions	
4TTB _____	38
4TTA _____	39
Mechanical Specifications	
4TTB _____	40
4TTA _____	41



## Features and Benefits

---

### Outdoor unit 4TTB

- Scroll compressor
- Efficiency up to 13 S E E R
- All aluminum SPINE FIN™ coil
- WEATHERGUARD™ fasteners
- QUICK-SESS™ cabinet, service access and refrigerant connections with full coil protection
- DURATUFF™ base, fast complete drain, weatherproof
- COMFORT-R™ mode approved
- Glossy corrosion resistant finish
- Internal compressor high/low pressure & temperature protection
- Liquidline filter supplied for field installations
- Polyslategray cabinet with anthracite gray badge and cap
- High pressure control
- Low pressure control
- Sump Heater/Crankcase Heater
- Service valve cover
- R-410A refrigerant
- S.E.E.T. design testing
- 100% line run test
- Low ambient cooling to 30°F with AY28X079
- Low ambient cooling to 55°F as shipped

### Outdoor unit 4TTA

- Scroll compressor
- Efficiency up to 13 S E E R
- All aluminum SPINE FIN™ coil
- WEATHERGUARD™ fasteners
- QUICK-SESS™ cabinet, service access and refrigerant connections with full coil protection
- DURATUFF™ base, fast complete drain, weatherproof
- COMFORT-R™ mode approved
- Glossy corrosion resistant finish
- Internal compressor high/low pressure & temperature protection
- Liquidline filter supplied for field installations
- Polyslate gray cabinet with anthracite gray badge and cap
- High pressure control
- Low pressure control
- Sump Heater/Crankcase Heater
- Service valve cover
- R-410A refrigerant
- S.E.E.T. design testing
- 100% line run test
- Low ambient cooling to 30°F with AY28X079
- Low ambient cooling to 55°F as shipped

## Features and Benefits

### MCD Concealed Unit

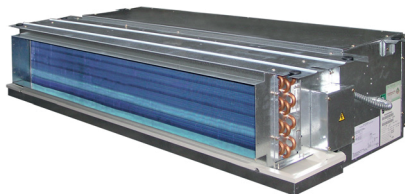

#### Features:

- Compact Design
- Triple Layer Drain Pan\*
- 4 Speed Fan Motor
- Optional Electric Heater

#### Benefits:

- Flexibility in installation locations.
- Protect against condensate leaks.
- Flexibility in airflow.
- Whisper quiet operation.
- Ease of installation

### MCD Air Handler unit

- Complete family of concealed models- available in capacities ranging from 18,000 to 60,000 Btu/h.
- Compact height- only 304 mm. for 18,000 to 24,000 Btu/h models and 408 mm for 30,000 to 60,000 Btu/h
- The MCD Series is very compact for easy installation into tight ceiling locations.
- Triple protection drain pan of three layers provide maximum insulation and water integrity. First, a single piece of galvanized steel; next, a single piece of polystyrene; and finally, a vacuum formed plastic liner.

- A** Plastic
- B** Polystyrene foam
- C** Galvanized sheet

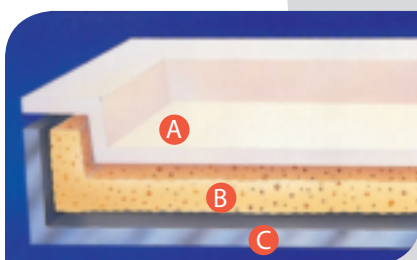

#### Triple protection drain pan

- Effectively prevents ceiling damage from drain pan leaks
- Decreases chance of mold
- Enhances indoor air quality

Illusion drain pans consist of three layers: a single piece of galvanized sheet, a single piece of polystyrene foam, and a vacuum formed plastic liner. It also features a high-quality, flexible drain hose which is suitable for PVC size.

# Features and Benefits

**Fan speed:**  
Four fan levels provide continuous, cool airflow

**Temperature setting:**  
Set temperature range is from 15 °C to 30 °C.

**Powercool (turbo) mode:**  
Cool off quicker (Turbo mode for LCD wired control)

**Sleep mode:**  
Stay comfortable with automatic room temperature adjustment during the night

**Econo mode:**  
Save energy while keeping cool

**Dry mode:**  
provides effective humidity reduction with high efficient cooling capacity.

**24 hours programmable timer:**  
Select on/off times to schedule even more energy and cost savings



Touch wired control  
(ACYSTAT160AA cooling only)  
(ACYSTAT260AA cool and heat)



LCD wired control  
(ACYSTAT110AA cooling only)  
(ACYSTAT210AA cool and heat)



LCD wireless remote control



Receiver  
(ACYSTAT120AA cooling only)  
(ACYSTAT220AA cool and heat)



LCD wireless remote control



Receiver

(ACYSTAT170AA Cooling Only)  
(ACYSTAT270AA Cool & Heat)

Digital touch-control series

- Choose from wired or wireless control
- Touch-control switch
- Intelligent features add more convenience



# Nomenclature

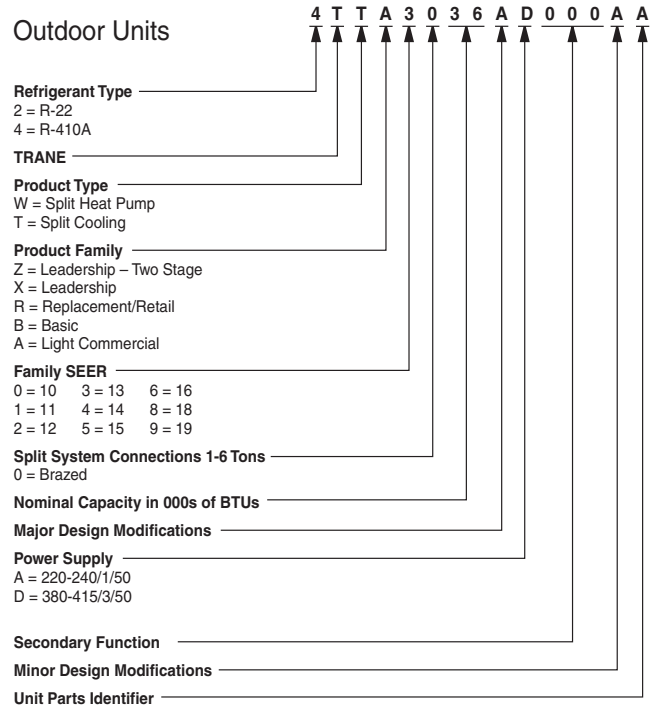
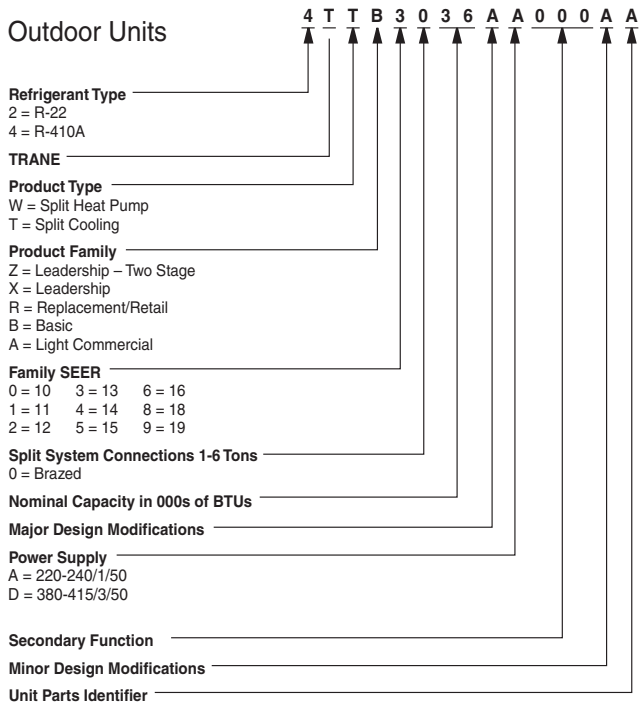



# Model Nomenclature

---

**M**   **C**   **D**   **A**   **1**   **2**   **D**   **B**   **P**   **H**   **A**   **A**  
**1**   **2**   **3**   **4**   **5**   **6**   **7**   **8**   **9**   **10**   **11**   **12**

## Digit 1

M = Mini-split

## Digit 2

C = Cooling only

## Digit 3

D = Concealed

## Digit 4- Refrigerant Connection

0 = Sweat type, R22

5 = Flare type, R22

A = Flare type, R410A (12-36)

B = Sweat type, R410A (48-60)

C = Flare type, R407C

D = Sweat type, R407C

## Digit 5, 6 – Nominal Capacity

12 = 12 MBH

18 = 18 MBH

24 = 24 MBH

30 = 30 MBH

36 = 36 MBH

48 = 48 MBH

60 = 60 MBH

## Digit 7

D = High external static pressure

E = Low external static pressure

## Digit 8 – Voltage

B = 220-240/50/1

D = 380 -415/50/3

## Digit 9- Electric Heat and Refrigerant

0 = no heat, no return plenum, standard option

5 = no heat, Egat no.5, standard option

C = 1.0 KW electric heat, no return plenum

D = 1.5 KW electric heat, no return plenum

E = 2.0 KW electric heat, no return plenum

F = 2.5 KW electric heat, no return plenum

G = 3.0 KW electric heat, no return plenum

H = 4.0 KW electric heat, no return plenum

I = 4.5 KW electric heat, no return plenum

P = no heat, with return plenum

Q = 1.0 KW electric heat, with return plenum

R = 1.5 KW electric heat, with return plenum

S = 2.0 KW electric heat, with return plenum

T = 2.5 KW electric heat, with return plenum

U = 3.0 KW electric heat, with return plenum

V = 4.0 KW electric heat, with return plenum

W = 4.5 KW electric heat, with return plenum

## Digit 10 – Option

0 = No option

H = High Efficiency with Filter

## Digit 11

A = Design change

## Digit 12

A = Service part





# General Data

## Product Specifications

Model No. ①	4TTB3018AA	4TTB3024AA	4TTB3030AA	4TTB3036AA
Electrical Data V/Ph/Hz <sup>2</sup>	220/240/1/50	220/240/1/50	220/240/1/50	220/240/1/50
Min Cir Ampacity	15	17	23	26
Max Fuse Size (Amps)	25	30	40	46
Compressors	SCROLL	SCROLL	SCROLL	SCROLL
NO. Used - No. Stages	1-1	1-1	1-1	1-1
RL AMPS - LR AMPS	10-52	12.1-60	15-67	17.9-87
Outdoor Fan FL Amps	1.4	1.4	1.2	1.2
Fan HP	1/6	1/6	1/5	1/5
Fan Dia (inches)	23	23	27.6	27.6
Coil	Spine Fin™	Spine Fin™	Spine Fin™	Spine Fin™
Refrigerant R-410A	5/9-LB/OZ	5/7-LB/OZ	7/0-LB/OZ	7/7-LB/OZ
Line Size - (in.) O.D. Gas <sup>3</sup>	3/4	3/4	3/4	7/8
Line Size - (in.) O.D. Liquid <sup>3</sup>	3/8	3/8	3/8	3/8
Dimensions HxWxD(creted)(in.)	34 x 30.1 x 33	34 x 30.1 x 33	42.4 x 35.1 x 38.7	42.4 x 35.1 x 38.7
Weight - Shipping (Kgs)	165	167	224	265
Weight - Net (Kgs)	138	140	189	230
Start Components	NO	NO	NO	NO
Sound Enclosure	NO	NO	NO	NO
Compressor Sump Heat/CrankCase Heater	YES	YES	YES	YES
<b>Optional Accessories: ④</b>				
Anti-short cycle Timer	TAYASCT501A	TAYASCT501A	TAYASCT501A	TAYASCT501A
Evaporator Defrost Control A/C	AY28X079	AY28X079	AY28X079	AY28X079
Rubber Isolator Kit	BAYISLT101	BAYISLT101	BAYISLT101	BAYISLT101
Extreme Condition Mounting Kit	BAYECMT023	BAYECMT023	BAYECMT004	BAYECMT004
Snow Leg - Base & Cap 4" High	BAYLEGS002	BAYLEGS002	BAYLEGS002	BAYLEGS002
Snow Leg - 4"Extension	BAYLEGS003	BAYLEGS003	BAYLEGS003	BAYLEGS003
Seacoast Kit	BAYSEAC001	BAYSEAC001	BAYSEAC001	BAYSEAC001
Refrigerant Lineset	TAYREFLN7*	TAYREFLN7*	TAYREFLN7*	TAYREFLN4*

② Calculated in accordance with N.E.C. Only use HACR circuit breakers or fuses.

③ Standard line lengths - 80'. Standard lift - 60' Suction and Liquid line.  
For Greater lengths and lifts refer to refrigerant piping software Pub# 32-3312-0 (latest revision)

④ For accessory description and usage, see pages 11.

## A-Weighted Sound Pressure Level [dB(A)]

MODEL	SOUND PRESSURE LEVEL [dB(A)]	A_WEIGHTED FULL OCTAVE SOUND PRESSURE LEVEL dB - [dB(A)]							
		63	125	250	500	1000	2000	4000	8000
4TTB3018A	57	39	46	46	50	47	43	39	33
4TTB3024A	61	46	47	47	50	56	46	43	41
4TTB3030A	44	46	42	48	50	49	46	40	36
4TTB3036A	59	49	46	51	50	49	45	38	34

② Tested as per JIS C9612-1994.



# General Data

## Product Specifications

Model No. ①	4TTA3030AD	4TTA3036AD	4TTA3042AD	4TTA3048AD	4TTA3060AD
Electrical Data V/Ph/Hz <sup>2</sup>	380-415/3/50	380-415/3/50	380-415/3/50	380-415/3/50	380-415/3/50
Min Cir Ampacity	9	11	12	12	14
Max Fuse Size (Amps)	15	19	21	21	25
Compressors	SCROLL	SCROLL	SCROLL	SCROLL	SCROLL
NO. Used - No. Stages	1-1	1-1	1-1	1-1	1-1
RL AMPS - LR AMPS	6.1 - 38	6.7 - 43	6.9 - 52	7.6 - 51.5	8.9 - 67.1
Outdoor Fan FL Amps	0.7	0.7	0.7	0.7	0.7
Fan HP	1-1/6	1-1/6	1-1/6	1-1/6	1-1/6
Fan Dia (inches)	27.6 - 1	27.6 - 1	27.6 - 1	27.6 - 1	27.6 - 1
Coil	Spine Fin™	Spine Fin™	Spine Fin™	Spine Fin™	Spine Fin™
Refrigerant R-410A	7/7 LB/OZ	8/5 LB/OZ	8/4 LB/OZ	9/8 LB/OZ	9/14 LB/OZ
Line Size - (in.) O.D. Gas <sup>3</sup>	3/4	7/8	7/8	7/8	7/8
Line Size - (in.) O.D. Liquid <sup>3</sup>	3/8	3/8	3/8	3/8	3/8
Dimensions HxWxD(creted)(in.)	42.4 x 35.1 x 38.7	42.4 x 35.1 x 38.7	46.4 x 35.1 x 38.7	51 x 35.1 x 38.7	51 x 35.1 x 38.7
Weight - Shipping (Lbs)	217	254	277	292	297
Weight - Net (Lbs)	182	219	240	255	260
Start Components	NO	NO	NO	NO	NO
Sound Enclosure	NO	NO	NO	NO	NO
Compressor Sump Heat/CrankCase Heater	YES	YES	YES	YES	YES
<b>Optional Accessories:</b>					
Anti-short cycle Timer	TAYASCT501A	TAYASCT501A	TAYASCT501A	TAYASCT501A	TAYASCT501A
Evaporator Defrost Control A/C	AY28X079	AY28X079	AY28X079	AY28X079	AY28X079
Rubber Isolator Kit	BAYISLT101	BAYISLT101	BAYISLT101	BAYISLT101	BAYISLT101
Extreme Condition Mounting Kit	BAYECMT023	BAYECMT023	BAYECMT004	BAYECMT004	BAYECMT004
Snow Leg - Base & Cap 4" High	BAYLEGS002	BAYLEGS002	BAYLEGS002	BAYLEGS002	BAYLEGS002
Snow Leg - 4" Extension	BAYLEGS003	BAYLEGS003	BAYLEGS003	BAYLEGS003	BAYLEGS003
Seacoast Kit	BAYSEAC001	BAYSEAC001	BAYSEAC001	BAYSEAC001	BAYSEAC001
Refrigerant Lineset	TAYREFLN7*	TAYREFLN4*	TAYREFLN4*	TAYREFLN4*	TAYREFLN4*

② Calculated in accordance with N.E.C. Only use HACR circuit breakers or fuses.

③ Standard line lengths - 80'. Standard lift - 60' Suction and Liquid line.  
For Greater lengths and lifts refer to refrigerant piping software Pub# 32-3312-0  
latest revision)

④ For accessory description and usage, see pages 11.

## A-Weighted Sound Pressure Level [dB(A)]

MODEL	SOUND PRESSURE LEVEL [dB(A)]	A_WEIGHTED FULL OCTAVE SOUND PRESSURE LEVEL dB - [dB(A)]							
		63	125	250	500	1000	2000	4000	8000
4TTA3030AD	60	51	42	52	50	54	43	38	33
4TTA3036AD	61	52	49	46	51	52	48	46	41
4TTB3042AD	70	55	47	52	52	52	46	40	36
4TTA3048AD	65	49	42	51	52	51	48	42	49
4TTA3060AD	59	26	31	39	47	48	46.4	44	35

② Tested as per JIS C9612-1994.



## General Data 4TTA/4TTB

---

### Accessory Description and Usage

Anti-Short Cycle Timer - Solid state timing device that prevents compressor recycling until 5 minutes have elapsed after satisfying call or power interruptions. Use in area with questionable power delivery, commercial applications, long lineset, etc.

Evaporator Defrost Control — SPST Temperature actuated switch that cycles the condenser off as indoor coil reaches freeze-up conditions. Used for low ambient cooling to 30°F with TXV.

Rubber Isolators — 5 large rubber donuts to isolate condensing unit from transmitting energy into mounting frame or pad. Use on any application where sound transmission needs to be minimized.

Extreme Condition Mount Kit — Bracket kits to securely mount condensing unit to a frame or pad without removing any panels. Use in areas with high winds, or on commercial roof tops, etc.

### AHRI Standard Capacity Rating Conditions

AHRI STANDARD 210/240 RATING CONDITIONS —  
(A) Cooling 80°F DB, 67°F WB air entering indoor coil, 95°F DB air entering outdoor coil.



## General Data/MCD 50 Hz

UNIT MODELS		MCDA18DBPHAA	MCDA24DBPHAA	MCDA30DBPHAA	MCDA36DBPHAA
POWER CONNECTION		MCDA18DBTHAA <sup>1</sup>	MCDA24DBUHAA <sup>1</sup>	MCDA30DBVHAA <sup>1</sup>	MCDA36DBWHAA <sup>1</sup>
MCA	V/ph/Hz A	220-240/1/50 1.0	220-240/1/50 1.4	220-240/1/50 3.9	220-240/1/50 2.9
<b>SYSTEM DATA</b>					
Refrigerant Type		R410A	R410A	R410A	R410A
Refrigerant Connection Type		Flare	Flare	Flare	Flare
Suction Line OD	in (mm)	3/4 (19.05)	3/4 (19.05)	3/4 (19.05)	7/8 (22.23)
Liquid line OD	in (mm)	3/8 (9.53)	3/8 (9.53)	3/8 (9.53)	3/8 (9.53)
<b>CASING</b>					
Material/Color		Galvanized Steel/Unpainted			
Type of Insulation/Thickness	in (mm)	Fiberglass (12.70)			
Insulation Density	Kg./m <sup>3</sup>	40	40	40	40
<b>COIL</b>					
Face Area	sq ft (m <sup>2</sup> )	2.1 (0.20)	2.1 (0.20)	2.33 (0.216)	3.50 (0.33)
Coil Size (HxL)	in	8" x 38"	8" x 38"	8" x 42"	14" x 36"
Tube Size OD	in (mm)	3/8 (9.53)	3/8 (9.53)	3/8 (9.53)	3/8 (9.53)
Tube Type		Inn. Grv.	Inn. Grv.	Inn. Grv.	Plain
Rows		4	4	4	4
Fin Type		Precoated Slit	Precoated Slit	Precoated Slit	Precoated Slit
Fins per inch		20	20	20	16
Refrigerant Flow Control		Capillary Tube	Capillary Tube	Capillary Tube	Capillary Tube
Drain Connection Size	in (mm)	1/2 (12.7)	1/2 (12.7)	1/2 (12.7)	1/2 (12.7)
<b>ELECTRIC HEATER DATA<sup>1</sup> (for electric heater option only)</b>					
Heater Rating	kW	2.5	3.0	4 (2 elements)	4.5 (2 elements)
Heater RLA		11.4	13.6	18.2	20.5
<b>FAN</b>					
Fan Type		Centrifugal	Centrifugal	Centrifugal	Centrifugal
No. used		2	2	2	2
Diameter	in (mm)	6 (144.0)	7 (164)	8 (203.2)	8 (203.2)
Width	in (mm)	7 (188.0)	8 (201)	9 (228.6)	9 (228.6)
Drive Type		Direct	Direct	Direct	Direct
<b>MOTOR</b>					
Motor Type		Permanent Split Capacitor			
No. of Motor		1	1	1	1
Motor Model		KDE2G4016	KDE2G4018	8555NVA-A28S	T2-0014-B
Motor Power	kW	0.087	0.128	0.399	0.210
No. of Speed		4	4	4	4
Motor Speed	rpm	1100/1200/1300/1400	1000/1100/1200/1400	850/1000/1100/1200	1000/900/800/700
Power Input	kW	0.179	0.237	0.684	0.454
Power Supply	V/ph/Hz	220/1/50	220/1/50	220-240/1/50	220-240/1/50
RLA/LRA		0.82/1.86	1.09/3.16	3.11/4.91	2.29/3.15
<b>FILTER</b>					
Type		Aluminium Filter	Aluminium Filter	Aluminium Filter	Aluminium Filter
No. used		2	2	2	2
Size (WxLxD)	in <sup>3</sup>	10.5x20.0x1.0	10.5x20.0x1.0	13.7 x 21.8 x 1.0	13.7 x 18.8 x 1.0
	(mm <sup>3</sup> )	(267x510x25.4)	(267x510x25.4)	(350 x 556 x 25.4)	(350 x 478 x 25.4)
<b>INDOOR SOUND DATA</b>	dBA (Speed - H/M/L)	49 / 49 / 46	53 / 49 / 46	61 / 60 / 58	55 / 52 / 49
<b>CONTROL DEVICE</b>					
Anti-Recycle Time		No	No	No	No
Thermostat		No	No	No	No
<b>DIMENSION (HxWxD)</b>					
Crated (Shipping)**	in <sup>3</sup>	13.2 x 51.6 x 22.1	13.2 x 51.6 x 22.1	18.9 x 51.9 x 30.6	18.9 x 46.0 x 30.6
	(mm) <sup>3</sup>	(335 x 1311 x 562)	(335 x 1311 x 562)	(479 x 1317 x 778)	(479 x 1168 x 778)
Uncrated (Net)**	in <sup>3</sup>	11.9 x 49.2 x 21.1	11.9 x 49.2 x 21.1	16 x 49.2 x 28.5	16 x 43.2 x 29.9
	(mm) <sup>3</sup>	(304 x 1251 x 538)	(304 x 1251 x 538)	(408 x 1251 x 724)	(408 x 1098 x 759)
<b>WEIGHT</b>					
Crated (Shipping)	lb (kg)	82 (37.2)	82 (37.2)	73 (32.73)	117 (51.3)
Crated (Shipping) <sup>1</sup>	lb (kg)	86 (39.2)	86 (39.2)	77 (34.73)	113 (53.3)
Uncrated (Net)	lb (kg)	79 (35.8)	79 (35.8)	64 (29.09)	103 (46.8)
Uncrated (Net) <sup>1</sup>	lb (kg)	83 (37.8)	83 (37.8)	68 (31.09)	107 (48.8)

MCA - Minimum Circuit Ampacity; calculated as follow : 125 % of motor R.L.Amps

<sup>1</sup> Model with electric heater has alphabetic letter T or Z in the ninth digit.



# General Data/MCD 50 Hz

UNIT MODELS		MCDB42DBPHAA	MCDB48DBPHAA	MCDB60DBPHAA
		MCDB42DBXHAA <sup>1</sup>	MCDB48DBXHAA <sup>1</sup>	MCDB60DBZHAA <sup>1</sup>
<b>POWER CONNECTION</b>	V/ph/Hz	220-240/1/50	220-240/1/50	220-240/1/50
<b>MCA</b>	A	3.9	3.9	4.9
<b>SYSTEM DATA</b>				
Refrigerant Type		R410A	R410A	R410A
Refrigerant Connection Type		Sweat	Sweat	Sweat
Suction Line OD	in (mm)	7/8 (22.23)	7/8 (22.23)	7/8 (22.23)
Liquid line OD	in (mm)	3/8 (9.53)	3/8 (9.53)	3/8 (9.53)
<b>CASING</b>				
Material/Color		Galvanized Steel/Unpainted		
Type of Insulation/Thickness	in (mm)	Fiberglass (12.70)		
Insulation Density	Kg./m <sup>3</sup>	40	40	40
<b>COIL</b>				
Face Area	sq ft (m <sup>2</sup> )	3.50 (0.33)	3.50 (0.33)	3/8 (9.53)
Coil Size (HxL)	in	14" x 36"	14" x 42"	14" x 42"
Tube Size OD	in (mm)	3/8 (9.53)	3/8 (9.53)	3/8 (9.53)
Tube Type		Plain	Inn. Grv.	Inn. Grv.
Rows		4	4	4
Fin Type		Precoated Slit	Precoated Slit	Precoated Slit
Fins per inch		18	15	20
Refrigerant Flow Control		Capillary Tube	Capillary Tube	Capillary Tube
Drain Connection Size	in (mm)	1/2 (12.7)	1/2 (12.7)	1/2 (12.7)
<b>ELECTRIC HEATER DATA<sup>1</sup> (for electric heater option only)</b>				
Heater Rating	kW	5.5 (2 elements)	6 (2 elements)	7 (2 elements)
Heater RLA		25.0	27.2	31.8
<b>FAN</b>				
Fan Type		Centrifugal	Centrifugal	Centrifugal
No. used		2	2	2
Diameter	in (mm)	8 (203.2)	8 (203.2)	8 (203.2)
Width	in (mm)	9 (228.6)	9 (228.6)	9 (228.6)
Drive Type		Direct	Direct	Direct
<b>MOTOR</b>				
Motor Type		Permanent Split Capacitor		
No. of Motor		1	1	1
Motor Model		8555NVA-A28S	8555NVA-A28S	8555NVA-A27S
Motor Power	kW	0.399	0.399	0.450
No. of Speed		4	4	4
Motor Speed	rpm	850/1000/1100/1200	850/1000/1100/1200	850/970/1100/1250
Power Input	kW	0.684	0.684	0.881
Power Supply	V/ph/Hz	220-240/1/50	220-240/1/50	220-240/1/50
RLA/LRA		3.11/4.91	3.11/4.91	3.94/7.15
<b>FILTER</b>				
Type		Aluminium Filter	Aluminium Filter	Aluminium Filter
No. used		2	2	2
Size (WxLxD)	in <sup>3</sup>	13.7 x 18.8 x 1.0	13.7 x 21.8 x 1.0	13.7 x 21.8 x 1.0
	(mm <sup>3</sup> )	(350 x 478 x 25.4)	(350 x 556 x 25.4)	(350 x 556 x 25.4)
<b>INDOOR SOUND DATA</b>				
	dBA (Speed - H/M/L)	63 / 61 / 57	64 / 62 / 58	63 / 61 / 58
<b>CONTROL DEVICE</b>				
Anti-Recycle Time		No	No	No
Thermostat		No	No	No
<b>DIMENSION (HxWxD)</b>				
Crated (Shipping)**	in <sup>3</sup>	18.9 x 46.0 x 30.6	19.3 x 51.9 x 30.8	19.3 x 51.9 x 30.8
	(mm) <sup>3</sup>	(479 x 1168 x 778)	(490 x 1317 x 782)	(490 x 1317 x 782)
Uncrated (Net)**	in <sup>3</sup>	16 x 43.2 x 29.9	16 x 49.2 x 29.8	16 x 49.2 x 29.8
	(mm) <sup>3</sup>	(408 x 1098 x 759)	(408 x 1251 x 759)	(408 x 1251 x 759)
<b>WEIGHT</b>				
Crated (Shipping)	lb (kg)	117 (51.3)	140 (63.7)	140 (63.7)
Crated (Shipping) <sup>1</sup>	lb (kg)	113 (53.3)	147 (66.7)	147 (66.7)
Uncrated (Net)	lb (kg)	103 (46.8)	130 (59)	130 (59)
Uncrated (Net) <sup>1</sup>	lb (kg)	107 (48.8)	137 (52)	137 (52)

MCA - Minimum Circuit Ampacity; calculated as follow : 125 % of motor R.L.Amps

<sup>1</sup> Model with electric heater has alphabetic letter T or Z in the ninth digit.



# Performance Data

Fan coil Airflow (CFM) versus. External Static Pressure (in.wg)

Table 5 - Indoor Fan performance

MCDA18DBPHAA										
SPEED	AIR FLOW (CFM)									
	260	300	340	380	420	460	500	540	580	600
LOW	0.16	0.13	0.09	0.05	0.00					
MED	0.27	0.24	0.20	0.16	0.11	0.06	0.00			
HIGH	0.31	0.28	0.24	0.20	0.15	0.10	0.05	0.00		
EXTRA HIGH	0.35	0.33	0.30	0.26	0.22	0.17	0.12	0.07	0.03	0.00

MCDA24DBPHAA										
SPEED	AIR FLOW (CFM)									
	460	500	540	580	620	660	700	740	780	820
LOW	0.22	0.16	0.09	0.00						
MED	0.28	0.24	0.20	0.14	0.08	0.00				
HIGH	0.33	0.30	0.27	0.23	0.19	0.15	0.10	0.05	0.00	
EXTRA HIGH	0.38	0.35	0.32	0.29	0.25	0.21	0.17	0.12	0.07	0.00

MCDA30DBPHAA										
SPEED	AIR FLOW (CFM)									
	640	700	760	820	880	940	1,000	1,060	1,120	1,180
LOW	0.30	0.28	0.23	0.17	0.11	0.05	0.00			
MED	0.38	0.35	0.30	0.24	0.18	0.12	0.06	0.00		
HIGH	0.42	0.39	0.34	0.28	0.22	0.17	0.11	0.05	0.00	
EXTRA HIGH	0.46	0.44	0.40	0.35	0.29	0.23	0.17	0.11	0.05	0.00

MCDA36DBPHAA										
SPEED	AIR FLOW (CFM)									
	500	580	660	740	820	900	980	1,060	1,140	1,220
LOW	0.26	0.22	0.15	0.08	0.00					
MEDIUM	0.36	0.33	0.28	0.22	0.15	0.08	0.00			
HIGH	0.43	0.41	0.37	0.32	0.26	0.19	0.11	0.00		
EXTRA HIGH	0.55	0.52	0.49	0.45	0.40	0.33	0.24	0.15	0.07	0.00



# Performance Data

Fan coil Airflow (CFM) versus. External Static Pressure (in.wg)

Indoor Fan Performance Table

MCDB42DBPHAA										
SPEED	AIR FLOW (CFM)									
	880	960	1,040	1,120	1,200	1,280	1,360	1,440	1,520	1,600
LOW	0.30	0.25	0.17	0.08	0.00					
MEDIUM	0.42	0.38	0.33	0.27	0.18	0.09	0.00			
HIGH	0.48	0.45	0.41	0.36	0.30	0.22	0.14	0.06	0.00	
EXTRA HIGH	0.53	0.51	0.47	0.42	0.37	0.31	0.23	0.15	0.07	0.00

MCDB48DBPHAA										
SPEED	AIR FLOW (CFM)									
	850	950	1,050	1,150	1,250	1,350	1,450	1,550	1,650	1,730
LOW	0.36	0.28	0.17	0.07	0.00					
MED	0.46	0.43	0.36	0.26	0.16	0.07	0.00			
HIGH	0.55	0.53	0.47	0.38	0.29	0.20	0.11	0.00		
EXTRA HIGH	0.66	0.64	0.60	0.54	0.45	0.36	0.27	0.18	0.08	0.00

MCDB60DBPHAA										
SPEED	AIR FLOW (CFM)									
	1,000	1,080	1,160	1,240	1,320	1,400	1,480	1,560	1,640	1,720
LOW	0.28	0.24	0.15	0.00						
MED	0.35	0.33	0.31	0.27	0.20	0.11	0.00			
HIGH	0.42	0.40	0.38	0.35	0.31	0.26	0.18	0.09	0.00	
EXTRA HIGH	0.52	0.50	0.47	0.44	0.39	0.33	0.26	0.18	0.09	0.00

# Fan Performance Data

---

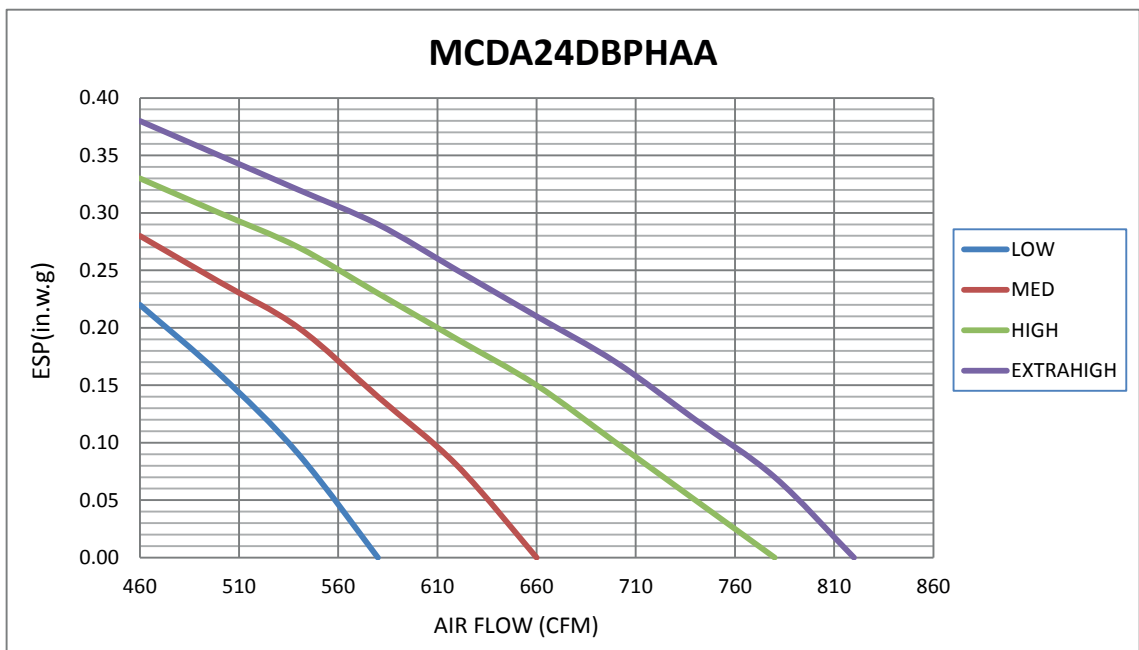
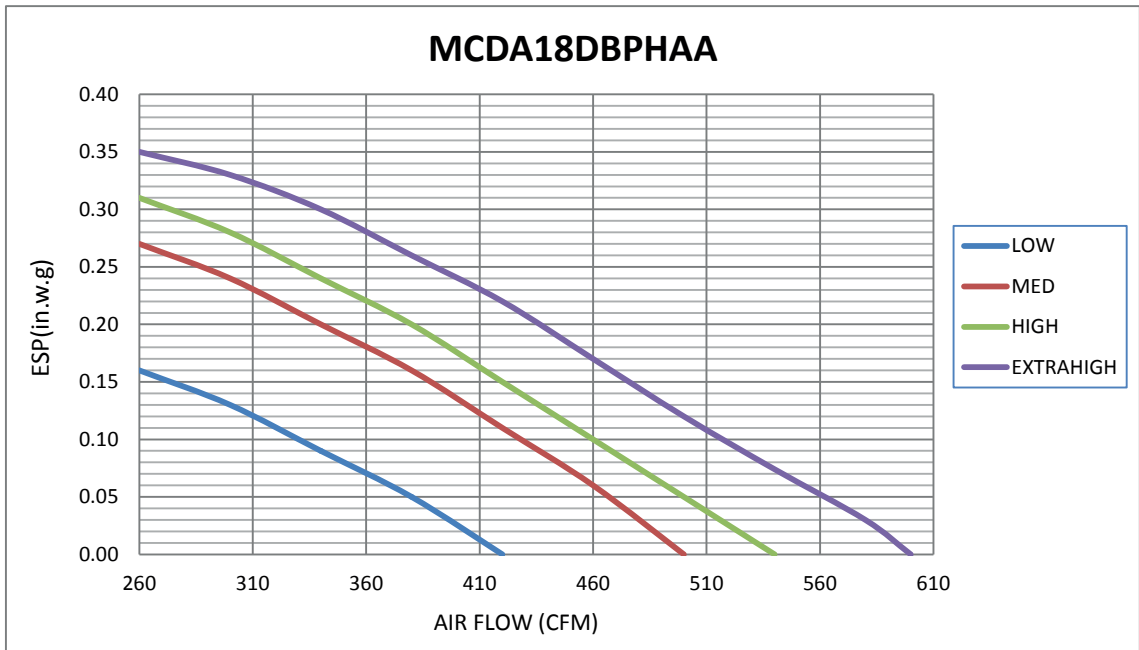



# Fan Performance Data

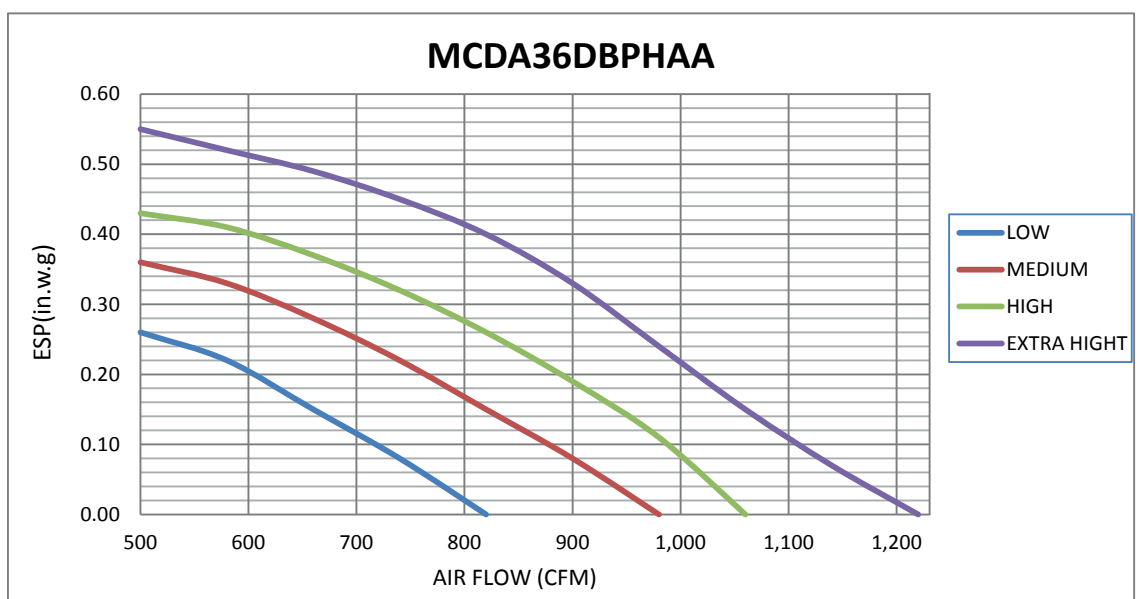
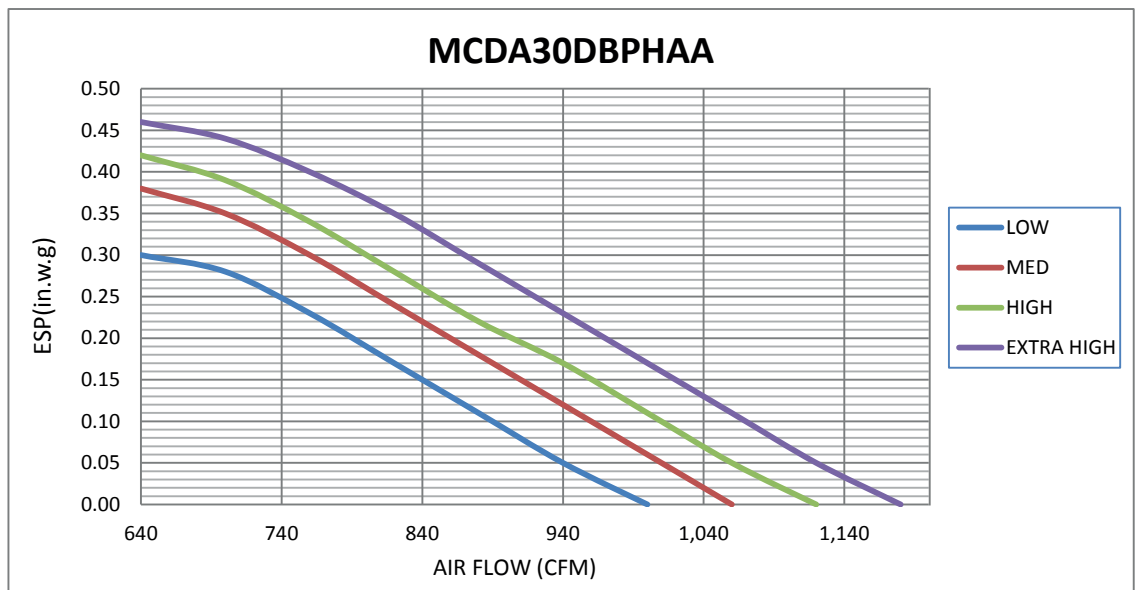

# Fan Performance Data

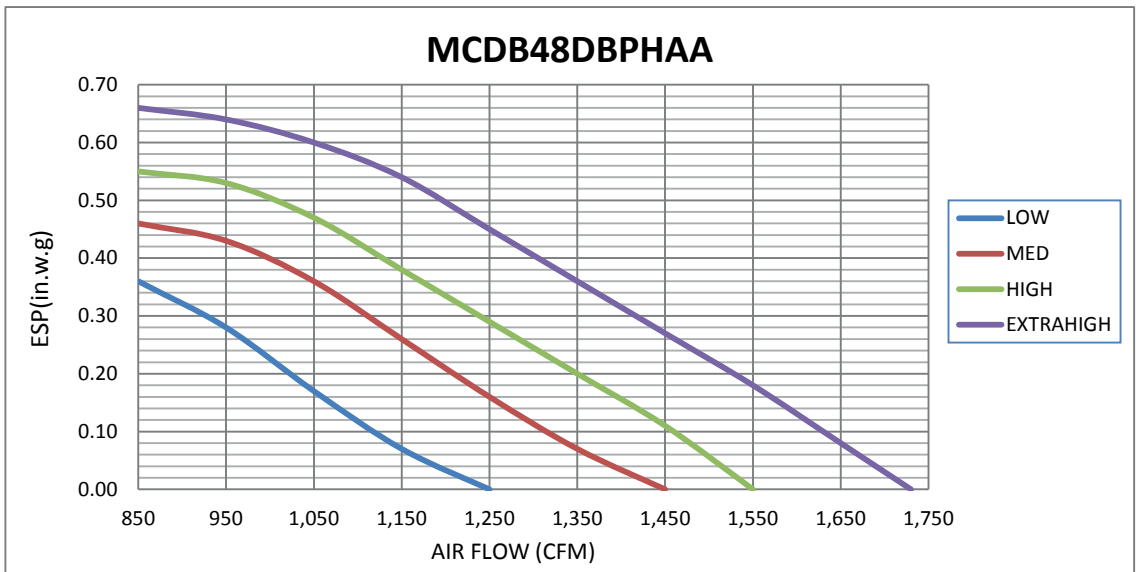
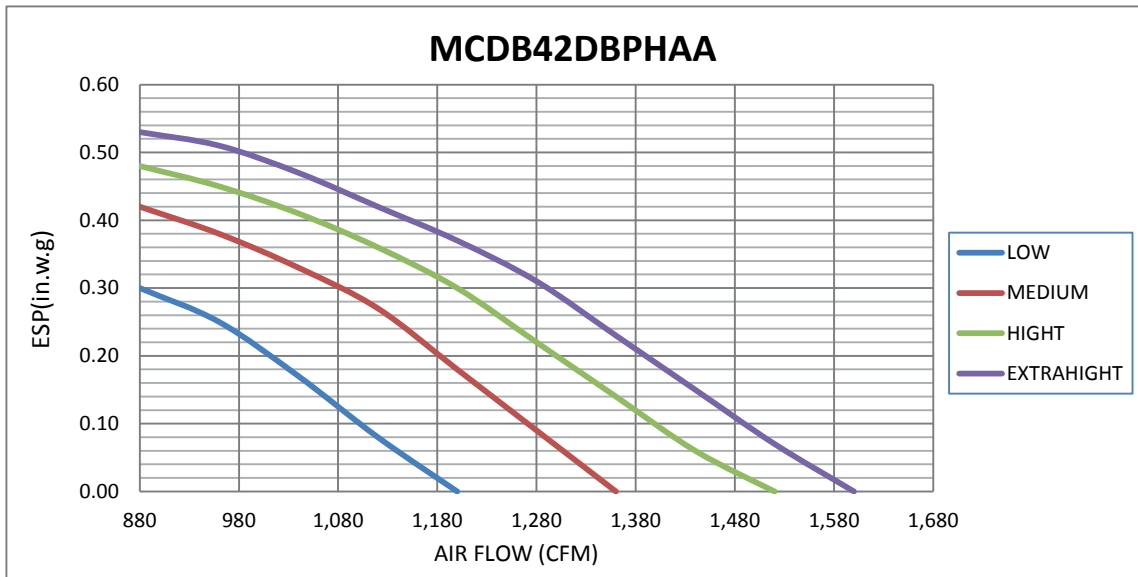

# Fan Performance Data

---

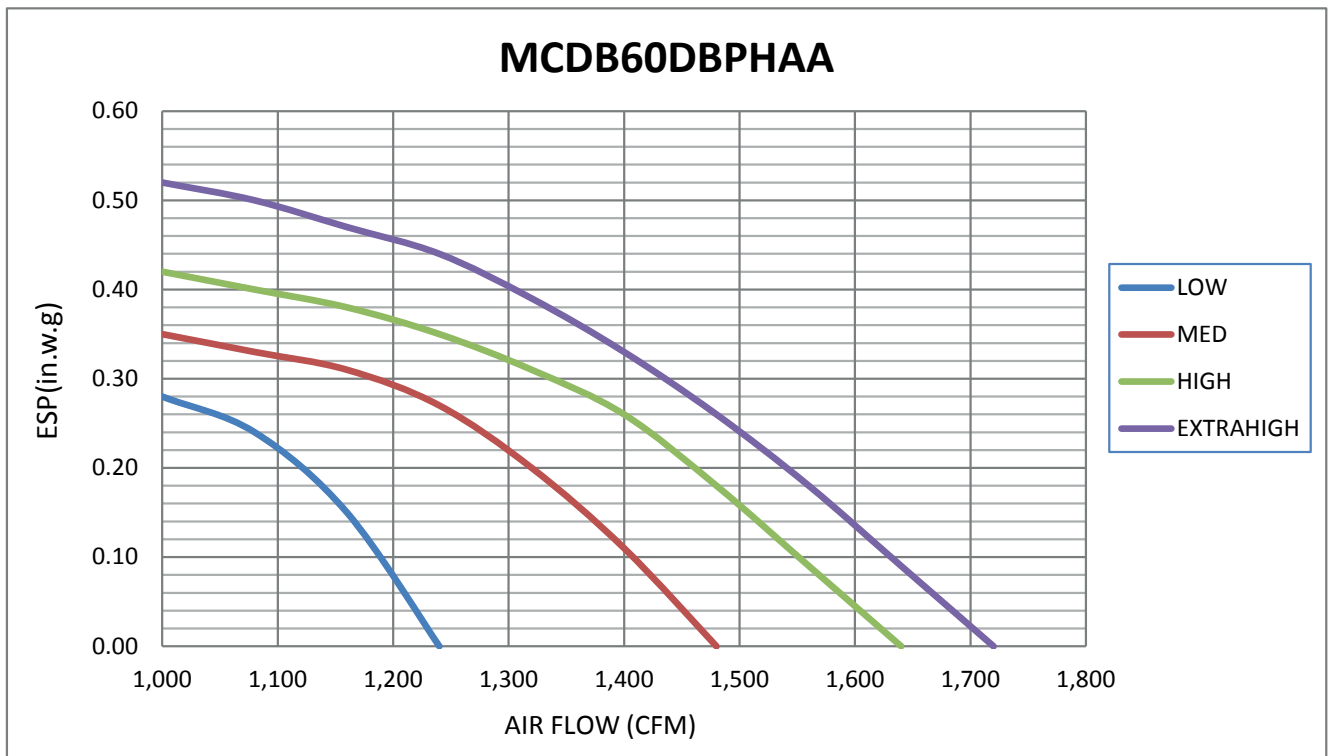



# Performance Data Cooling

4TTB3018AA WITH MCDA18 AT 510 CFM \*\* NET CAPACITY IN BTU/H X 1000

O.D.D.B.	I.D.W.B.	TOTAL CAPACITY	SENSIBLE CAPACITY				SYSTEM kW
			72	75	78	80	
85	59	16.41	12.98	14.39	15.75	16.38	1.459
85	63	17.44	10.82	12.32	13.90	14.84	1.460
85	67	19.10	8.78	10.28	11.76	13.10	1.462
95	59	15.70	12.51	13.91	15.18	15.70	1.622
95	63	16.51	10.39	11.96	13.44	14.38	1.625
95	67	18.98	8.77	10.34	11.89	13.33	1.635
105	63	15.51	10.03	11.50	12.94	13.85	1.808
105	67	16.90	7.87	9.35	10.86	12.21	1.814
105	71	18.21	5.77	7.30	8.76	9.74	1.815
115	63	14.38	9.59	10.99	12.47	13.48	2.013
115	67	15.55	7.37	8.91	10.47	11.78	2.025
115	71	16.97	5.32	6.80	8.30	9.29	2.030
118.4	67	15.07	7.24	8.77	10.31	11.57	2.119
120	63	13.86	9.26	10.72	12.23	13.22	2.127
120	67	14.90	7.14	8.73	10.19	11.48	2.132
120	71	16.35	5.04	6.55	8.04	9.06	2.142
125	63	13.32	9.00	10.50	12.06	12.90	2.247
125	67	14.40	6.95	8.46	9.93	11.22	2.254
125	71	15.71	4.79	6.35	7.82	8.73	2.262
125.6	67	14.30	6.9	8.5	9.9	11.20	2.269
*** 95	67	18.98	IDDB=	80.00	13.33		1.635

VALUES AT ARI RATING CONDITIONS  
NET CAPACITY= 18,980 BTUH  
AIRFLOW = 510 CFM  
COMPRESSOR POWER = 1,256 WATTS  
I.D. FAN POWER = 185 WATTS  
O.D. FAN POWER = 194 WATTS  
COP = 3.4  
E.E.R. = 11.61 BTUH/W

**CORRECTION FACTORS - OTHER AIRFLOWS**  
(Multiply or Add as indicated)  
AIRFLOW 425 575  
TOTALCAP. x 0.96 x 1.025  
SENS. CAP x 0.91 x 1.065  
COMPRESSOR KW x 0.998 x 1.001

Rated with 25 Feet 3/4 suction 3/8 liquid lines

\*\*\* Performance at selected design conditions

\* Dry coil condition (Total Capacity = Sensible Capacity)

Total capacity, compressor kW and app. dew point valid only for wetcoil

All temperatures in Degree F

4TTB3024AA WITH MCDA24 AT 750 CFM \*\* NET CAPACITY IN BTU/H X 1000

O.D.D.B.	I.D.W.B.	TOTAL CAPACITY	SENSIBLE CAPACITY				SYSTEM kW
			72	75	78	80	
85	59	20.84	16.63	18.39	20.22	20.84	1.776
85	63	22.10	14.02	15.88	17.77	19.01	1.782
85	67	24.07	11.19	13.10	15.06	17.16	1.789
95	59	19.89	16.00	17.85	19.42	19.89	1.950
95	63	20.86	13.50	15.34	17.23	18.39	1.956
95	67	24.03	11.40	13.50	15.55	17.66	1.966
105	63	19.52	12.96	14.82	16.58	17.81	2.152
105	67	21.15	10.26	12.19	14.05	16.08	2.162
105	71	22.81	7.40	9.31	11.25	12.56	2.171
115	63	18.15	12.34	14.17	15.99	17.23	2.374
115	67	19.40	9.74	11.64	13.49	15.45	2.385
115	71	21.29	6.87	8.87	10.83	12.09	2.396
118.4	67	18.76	9.54	11.43	13.25	15.24	2.467
120	63	17.41	11.95	13.76	15.69	16.86	2.494
120	67	18.50	9.45	11.30	13.16	15.11	2.507
120	71	20.48	6.60	8.66	10.56	11.81	2.518
125	63	16.69	11.58	13.51	15.32	16.49	2.623
125	67	17.80	9.13	11.00	12.82	14.67	2.635
125	71	19.64	6.44	8.39	10.27	11.54	2.647
125.6	67	17.70	9.10	10.9	12.7	14.6	2.651
*** 95	67	24.03	IDDB=	80.00	17.66		1.966

VALUES AT ARI RATING CONDITIONS  
NET CAPACITY= 24,037 BTUH  
AIRFLOW = 750 CFM  
COMPRESSOR POWER = 1494 WATTS  
I.D. FAN POWER = 258 WATTS  
O.D. FAN POWER = 214 WATTS  
COP = 3.58  
E.E.R. = 12.2 BTUH/W

**CORRECTION FACTORS - OTHER AIRFLOWS**  
(Multiply or Add as indicated)  
AIRFLOW 675 825  
TOTALCAP. x 0.96 x 1.03  
SENS. CAP x 0.92 x 1.09  
COMPRESSOR KW x 0.99 x 1.01

Rated with 25 Feet 3/4 suction 3/8 liquid lines

Compressor Watts = 2,011 @ 118.4F

\*\*\* Performance at selected design conditions

\* Dry coil condition (Total Capacity = Sensible Capacity)

Total capacity, compressor kW and app. dew point valid only for wetcoil

All temperatures in Degree F



# Performance Data Cooling

4TTB3030AA WITH MCDA30 AT 980 CFM \*\* NET CAPACITY IN BTU/H X 1000

O.D.D.B.	I.D.W.B.	TOTAL CAPACITY	SENSIBLE CAPACITY				SYSTEM kW
			72	75	78	80	
85	59	25.88	22.48	25.31	26.21	26.82	2.099
85	63	27.04	18.00	21.17	24.31	26.29	2.100
85	67	28.53	13.67	16.54	19.67	21.72	2.110
95	59	25.00	22.00	24.14	25.08	25.68	2.333
95	63	25.76	17.48	20.59	23.68	25.66	2.334
95	67	28.10	13.55	16.65	19.85	21.99	2.344
105	63	24.47	16.93	19.98	23.16	24.47	2.597
105	67	25.60	12.53	15.29	18.61	20.58	2.605
105	71	27.22	7.34	10.87	13.81	16.10	2.620
115	63	23.14	16.30	19.42	22.52	23.14	2.896
115	67	23.95	11.94	14.72	17.82	20.06	2.903
115	71	25.22	6.89	10.06	13.20	15.33	2.914
118.4	67	23.38	11.41	14.53	17.63	19.83	3.013
120	63	22.45	15.81	19.15	21.87	22.45	3.061
120	67	23.10	11.31	14.44	17.50	19.63	3.065
120	71	24.35	6.58	9.86	12.88	15.29	3.079
125	63	21.70	15.49	18.83	21.12	21.70	3.239
125	67	22.23	10.99	14.14	17.38	19.53	3.242
125	71	23.41	6.37	9.58	12.67	14.74	3.252
125.6	67	22.10	10.9	14.10	17.4	19.4	3.263
*** 95	67	28.10	IDDB=	80.00	21.99		2.344

VALUES AT ARI RATING CONDITIONS  
 NET CAPACITY= 28,100 BTUH  
 AIRFLOW = 980 CFM  
 COMPRESSOR POWER = 1785 WATTS  
 I.D. FAN POWER = 377 WATTS  
 O.D. FAN POWER = 182 WATTS  
 COP = 3.51  
 E.E.R. = 11.99 BTUH/W

**CORRECTION FACTORS - OTHER AIRFLOWS**  
 (Multiply or Add as indicated)  
 AIRFLOW 900 1050  
 TOTALCAP. x 0.984 x 1.02  
 SENS. CAP x 0.945 x 1.07  
 COMPRESSOR KW x 0.998 x 1.01

Rated with 25 Feet 3/4 suction 3/8 liquid lines

Compressor Watts = 2,463 @ 118.4F

\*\*\* Performance at selected design conditions  
 \* Dry coil condition (Total Capacity = Sensible Capacity)  
 Total capacity, compressor kW and app. dew point valid only for wetcoil  
 All temperatures in Degree F

4TTB3036AA WITH MCDA36 AT 1080 CFM \*\* NET CAPACITY IN BTU/H X 1000

O.D.D.B.	I.D.W.B.	TOTAL CAPACITY	SENSIBLE CAPACITY				SYSTEM kW
			72	75	78	80	
85	59	30.03	23.76	26.64	29.20	30.03	2.490
85	63	31.62	19.45	22.45	25.37	27.28	2.499
85	67	33.92	14.83	17.94	20.97	25.03	2.512
95	59	28.64	23.00	25.86	27.97	28.64	2.772
95	63	29.90	18.74	21.72	24.64	26.55	2.780
95	67	33.24	14.16	17.26	20.30	24.28	2.776
105	63	28.11	18.02	20.99	23.89	25.80	3.095
105	67	30.12	13.50	16.57	19.59	23.50	3.110
105	71	32.32	8.66	11.88	14.99	17.04	3.125
115	63	26.18	17.30	20.25	23.15	24.97	3.452
115	67	28.11	12.82	15.89	18.90	22.74	3.467
115	71	30.18	8.02	11.22	14.34	16.38	3.484
118.4	67	27.44	12.57	15.65	18.66	22.48	3.607
120	63	25.22	16.91	19.87	22.77	24.52	3.648
120	67	27.02	12.45	15.53	18.53	22.33	3.664
120	71	29.08	7.71	10.89	14.01	16.07	3.681
125	63	24.25	16.55	19.47	22.37	23.94	3.859
125	67	25.93	12.10	15.17	18.17	21.95	3.872
125	71	27.88	7.37	10.56	13.71	15.72	3.887
125.6	67	25.80	12.1	15.1	18.1	21.90	3.898
***95	67	33.24	14.16	17.26	20.30	22.27	2.776

VALUES AT ARI RATING CONDITIONS  
 NET CAPACITY= 33,242 BTUH  
 AIRFLOW = 1080 CFM  
 COMPRESSOR POWER = 2245 WATTS  
 I.D. FAN POWER = 348 WATTS  
 O.D. FAN POWER = 183 WATTS  
 COP = 3.51  
 E.E.R. = 11.981 BTUH/W

**CORRECTION FACTORS - OTHER AIRFLOWS**  
 (Multiply or Add as indicated)  
 AIRFLOW 950 1150  
 TOTALCAP. x 0.98 x 1.02  
 SENS. CAP x 0.943 x 1.06  
 COMPRESSOR KW x 0.998 x 1.01

Rated with 25 Feet 7/8 suction 3/8 liquid lines

Compressor Watts = 3,079 @ 118.4F

\*\*\* Performance at selected design conditions  
 \* Dry coil condition (Total Capacity = Sensible Capacity)  
 Total capacity, compressor kW and app. dew point valid only for wetcoil  
 All temperatures in Degree F



# Performance Data Cooling

## 4TTA3030AD WITH MCDA30 AT 982 CFM \*\* NET CAPACITY IN BTU/H X 1000

O.D.D.B.	I.D.W.B.	TOTAL CAPACITY	SENSIBLE CAPACITY				SYSTEM kW
			72	75	78	80	
85	59	28.25	23.39	26.29	27.59	28.25	2.311
85	63	28.81	18.82	21.94	25.02	27.05	2.313
85	67	31.49	14.20	17.33	20.40	22.48	2.320
95	59	27.03	22.81	25.46	26.39	27.03	2.561
95	63	27.32	18.21	21.33	24.40	26.36	2.562
95	67	29.83	13.62	16.76	19.85	21.88	2.571
105	63	25.51	17.33	20.38	23.44	25.28	2.843
105	67	27.35	12.84	15.89	18.96	20.97	2.852
105	71	28.85	8.25	11.32	14.36	16.40	2.866
115	63	23.35	16.29	19.29	22.15	23.35	3.154
115	67	24.59	11.91	14.88	17.88	19.87	3.164
115	71	26.23	7.47	10.41	13.02	15.38	3.179
118.4	67	23.61	11.42	14.45	17.38	19.37	3.278
120	63	22.17	15.64	18.62	21.34	22.17	3.324
120	67	23.21	11.26	14.28	17.20	19.18	3.333
120	71	24.85	6.67	9.78	12.50	14.85	3.349
125	63	20.78	14.82	17.68	20.26	20.78	3.502
125	67	21.65	10.51	13.52	16.37	18.31	3.510
125	71	23.14	6.14	9.22	11.98	14.07	3.526
125.6	67	21.54	10.5	13.5	16.3	18.3	3.532
*** 95	67	29.83	IDDB=	80.00	21.88		2.571

VALUES AT ARI RATING CONDITIONS  
NET CAPACITY= 29,830 BTUH  
AIRFLOW = 982 CFM  
COMPRESSOR POWER = 1993 WATTS  
I.D. FAN POWER = 367 WATTS  
O.D. FAN POWER = 211 WATTS  
COP = 3.40  
E.E.R. = 11.6 BTUH/W

**CORRECTION FACTORS - OTHER AIRFLOWS**  
(Multiply or Add as indicated)  
AIRFLOW 900 1050  
TOTALCAP. x 0.98 x 1.02  
SENS. CAP x 0.93 x 1.07  
COMPRESSOR KW x 0.99 x 1.01

Rated with 25 Feet 3/4 suction 3/8 liquid lines

Compressor Watts = 2,645 @ 118.4F

\*\*\* Performance at selected design conditions

\* Dry coil condition (Total Capacity = Sensible Capacity)

Total capacity, compressor kW and app. dew point valid only for wetcoil

All temperatures in Degree F

## 4TTA3036AD WITH MCDA36 AT 1082 CFM \*\* NET CAPACITY IN BTU/H X 1000

O.D.D.B.	I.D.W.B.	TOTAL CAPACITY	SENSIBLE CAPACITY				SYSTEM kW
			72	75	78	80	
85	59	32.09	25.67	28.91	31.34	32.09	2.660
85	63	33.38	20.63	24.09	27.55	29.77	2.666
85	67	36.73	15.34	18.88	22.39	24.70	2.678
95	59	30.61	24.88	28.08	29.86	30.61	2.948
95	63	31.57	19.88	23.34	26.78	29.02	2.953
95	67	34.40	14.64	18.19	21.68	26.13	2.964
105	63	29.01	18.74	22.10	25.43	27.50	3.282
105	67	31.54	13.68	17.12	20.53	24.83	3.293
105	71	33.22	8.43	11.92	15.39	17.68	3.305
115	63	26.51	17.61	20.92	24.10	26.07	3.664
115	67	28.44	12.71	16.07	19.40	23.52	3.673
115	71	30.66	7.61	11.04	14.45	16.65	3.684
118.4	67	27.35	12.34	15.66	18.94	23.00	3.814
120	63	25.29	17.04	20.29	23.40	25.16	3.876
120	67	26.90	12.23	15.55	18.81	22.89	3.883
120	71	28.91	7.21	10.59	13.96	16.14	3.895
125	63	24.25	16.67	19.90	22.99	24.24	4.105
125	67	25.77	11.86	15.18	18.44	22.46	4.111
125	71	27.69	6.88	10.28	13.60	15.82	4.118
125.6	67	25.63	11.8	15.1	18.4	22.4	4.139
*** 95	67	34.40	IDDB=	80.00	26.13		2.964

VALUES AT ARI RATING CONDITIONS  
NET CAPACITY= 34,400 BTUH  
AIRFLOW = 1082 CFM  
COMPRESSOR POWER = 2405 WATTS  
I.D. FAN POWER = 348 WATTS  
O.D. FAN POWER = 211 WATTS  
COP = 3.40  
E.E.R. = 11.6 BTUH/W

**CORRECTION FACTORS - OTHER AIRFLOWS**  
(Multiply or Add as indicated)  
AIRFLOW 1000 1150  
TOTALCAP. x 0.98 x 1.02  
SENS. CAP x 0.93 x 1.07  
COMPRESSOR KW x 0.99 x 1.01

Rated with 25 Feet 7/8 suction 3/8 liquid lines

Compressor Watts = 3,288 @ 118.4F

\*\*\* Performance at selected design conditions

\* Dry coil condition (Total Capacity = Sensible Capacity)

Total capacity, compressor kW and app. dew point valid only for wetcoil

All temperatures in Degree F



# Performance Data Cooling

## 4TTA3042AD WITH MCDB42 AT 1259 CFM \*\* NET CAPACITY IN BTU/H X 1000

O.D.D.B.	I.D.W.B.	TOTAL CAPACITY	SENSIBLE CAPACITY				SYSTEM kW
			72	75	78	80	
85	59	39.58	31.59	35.80	38.79	39.58	3.256
85	63	41.28	25.41	29.60	33.82	36.55	3.270
85	67	44.99	19.10	23.31	27.50	31.47	3.291
95	59	37.41	30.37	34.38	36.57	37.41	3.600
95	63	38.69	24.27	28.41	32.54	35.27	3.612
95	67	42.22	18.08	22.23	26.39	30.29	3.635
105	63	35.33	22.66	26.67	30.68	33.21	3.997
105	67	38.40	16.71	20.74	24.75	28.49	4.022
105	71	40.20	10.62	14.68	18.72	21.39	4.052
115	63	32.42	21.33	25.26	29.16	31.52	4.431
115	67	34.50	15.54	19.52	23.38	27.05	4.456
115	71	36.90	9.64	13.63	17.56	20.14	4.487
118.4	67	33.32	15.10	18.99	22.86	26.43	4.615
120	63	30.86	20.57	24.41	28.21	30.47	4.666
120	67	32.76	14.90	18.78	22.60	26.15	4.691
120	71	35.02	9.11	13.00	16.90	19.46	4.722
125	63	29.74	20.12	23.95	27.80	29.65	4.916
125	67	31.53	14.47	18.34	22.19	25.75	4.940
125	71	33.70	8.74	12.64	16.46	19.06	4.970
125.6	67	31.37	14.4	18.3	22.1	25.70	4.971
*** 95	67	42.22	IDDB=	80.00	30.29		3.635

VALUES AT ARI RATING CONDITIONS  
 NET CAPACITY= 42,220 BTUH  
 AIRFLOW = 1259 CFM  
 COMPRESSOR POWER = 2904 WATTS  
 I.D. FAN POWER = 520 WATTS  
 O.D. FAN POWER = 211 WATTS  
 COP = 3.40  
 E.E.R. = 11.6 BTUH/W

**CORRECTION FACTORS - OTHER AIRFLOWS**  
 (Multiply or Add as indicated)  
 AIRFLOW 1175 1325  
 TOTALCAP. x 0.98 x 1.02  
 SENS. CAP x 0.93 x 1.07  
 COMPRESSOR KW x 0.99 x 1.01

Rated with 25 Feet 7/8 suction 3/8 liquid lines

Compressor Watts = 3,869 @ 118.4F

\*\*\* Performance at selected design conditions  
 \* Dry coil condition (Total Capacity = Sensible Capacity)  
 Total capacity, compressor kW and app. dew point valid only for wetcoil  
 All temperatures in Degree F

## 4TTA3048AD WITH MCDB48 AT 1369 CFM \*\* NET CAPACITY IN BTU/H X 1000

O.D.D.B.	I.D.W.B.	TOTAL CAPACITY	SENSIBLE CAPACITY				SYSTEM kW
			72	75	78	80	
85	59	43.22	34.90	39.16	42.45	43.37	3.630
85	63	44.81	28.31	32.43	37.55	40.46	3.644
85	67	50.34	22.07	26.66	31.03	34.20	3.675
95	59	41.27	33.72	38.10	40.47	41.45	4.013
95	63	42.37	27.04	31.60	36.31	39.15	4.024
95	67	47.16	21.19	25.59	29.78	33.00	4.060
105	63	38.50	24.98	29.86	33.99	36.91	4.449
105	67	43.00	19.44	23.51	27.60	30.85	4.490
105	71	44.97	13.09	18.07	22.02	24.67	4.526
115	63	35.24	23.79	28.10	32.02	34.75	4.927
115	67	37.95	17.70	21.70	25.75	28.95	4.965
115	71	41.21	11.72	16.29	20.38	23.02	5.011
118.4	67	36.66	16.92	20.76	25.18	28.11	5.192
120	63	33.36	22.80	26.93	31.16	33.23	5.188
120	67	35.76	16.79	20.52	25.12	27.92	5.224
120	71	38.83	10.90	15.42	19.20	21.80	5.274
125	63	32.17	22.23	26.22	30.47	32.24	5.461
125	67	34.32	16.05	20.20	24.65	27.29	5.501
125	71	37.31	10.41	14.78	18.53	21.07	5.549
125.6	67	34.12	15.9	20.2	24.6	27.2	5.534
*** 95	67	47.16	IDDB=	80.00	33.00		4.060

VALUES AT ARI RATING CONDITIONS  
 NET CAPACITY= 47,160 BTUH  
 AIRFLOW = 1369 CFM  
 COMPRESSOR POWER = 3313 WATTS  
 I.D. FAN POWER = 568 WATTS  
 O.D. FAN POWER = 180 WATTS  
 COP = 3.40  
 E.E.R. = 11.6 BTUH/W

**CORRECTION FACTORS - OTHER AIRFLOWS**  
 (Multiply or Add as indicated)  
 AIRFLOW 1300 1450  
 TOTALCAP. x 0.99 x 1.02  
 SENS. CAP x 0.97 x 1.03  
 COMPRESSOR KW x 0.99 x 1.002

Rated with 25 Feet 7/8 suction 3/8 liquid lines

Compressor Watts =4,439 @ 118.4F

\*\*\* Performance at selected design conditions  
 \* Dry coil condition (Total Capacity = Sensible Capacity)  
 Total capacity, compressor kW and app. dew point valid only for wetcoil  
 All temperatures in Degree F



# Performance Data Cooling

4TTA3060AD WITH MCDB60 AT 1525 CFM \*\* NET CAPACITY IN BTU/H X 1000

O.D.D.B	I.D.W.B.	TOTAL CAPACITY	SENSIBLE CAPACITY				SYSTEM kW
			72	75	78	80	
85	59	49.85	39.71	44.31	48.42	49.87	4.150
85	63	51.85	31.82	36.83	42.60	45.77	4.174
85	67	57.58	25.34	30.17	34.94	40.82	4.228
95	59	47.47	38.11	42.68	46.28	47.50	4.613
95	63	48.99	30.51	36.10	41.19	44.23	4.632
95	67	54.61	23.85	28.67	33.42	39.14	4.704
105	63	45.56	29.30	34.43	39.16	42.06	5.148
105	67	50.07	22.13	26.82	31.49	37.92	5.198
105	71	53.32	14.90	20.39	25.09	28.19	5.262
115	63	42.05	27.99	32.67	37.27	40.61	5.716
115	67	45.27	20.43	25.61	30.79	36.50	5.769
115	71	49.55	13.86	18.78	23.40	26.46	5.840
118.4	67	43.80	19.66	25.21	30.20	35.67	6,010
120	63	39.32	26.39	31.07	35.44	38.64	6.022
120	67	42.48	19.06	24.51	29.29	34.84	6,100
120	71	46.48	13.01	17.49	21.99	24.96	6.150
125	63	37.35	25.25	29.78	34.84	37.01	6.343
125	67	40.15	18.61	23.48	28.14	33.36	6.395
125	71	43.66	12.07	16.47	20.91	24.51	6.462
125.6	67	39.55	18.3	23.2	27.8	33.0	6.435
*** 95	67	54.61	IDDB=	80.00	36.58		4.688

VALUES AT ARI RATING CONDITIONS  
NET CAPACITY= 54,610 BTUH  
AIRFLOW = 1525 CFM  
COMPRESSOR POWER = 3969 WATTS  
I.D. FAN POWER = 554 WATTS  
O.D. FAN POWER = 180 WATTS  
COP = 3.40  
E.E.R. = 11.6 BTUH/W

**CORRECTION FACTORS - OTHER AIRFLOWS**  
(Multiply or Add as indicated)  
AIRFLOW 1450 1600  
TOTALCAP. x 0.98 x 1.00  
SENS. CAP x 0.97 x 1.03  
COMPRESSOR KW x 1.00 x 1.01

Rated with 25 Feet 7/8 suction 3/8 liquid lines

Compressor Watts = 5,249 @ 118.4F

\*\*\* Performance at selected design conditions  
\* Dry coil condition (Total Capacity = Sensible Capacity)  
Total capacity, compressor kW and app. dew point valid only for wetcoil  
All temperatures in Degree F



# MCD Wiring Diagram

**COOLING ONLY**  
**MCDA18-536**  
**MCDB42-60**

Remove HI-BR wire from TB-1 and replace with EXTRA HI-BLK wire when high speed/cfm is required in the field.

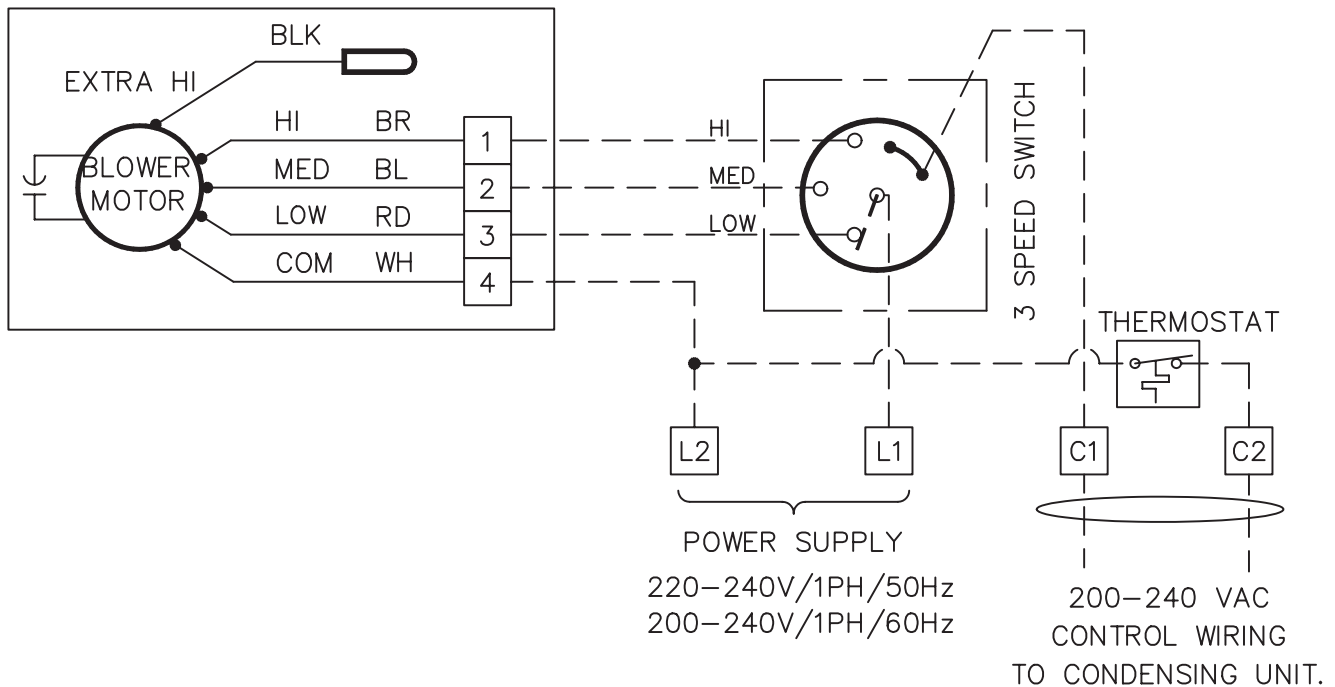

**LEGEND :**

- FIELD WIRING
- FACTORY WIRING

**NOTES :**

1. Power wiring and grounding of equipment must comply with local codes.
2. Ensure that power supply agrees with equipment nameplate.
3. Use only copper conductors.

# MCD Wiring Diagram

## COOLING HEATING MCDA18-524DB

REMOVE HI-BR WIRE FROM TB-1 AND REPLACE WITH EXTRA HI-BLK WIRE WHEN HI SPEED/CFM IS REQUIRED IN THE FIELD.

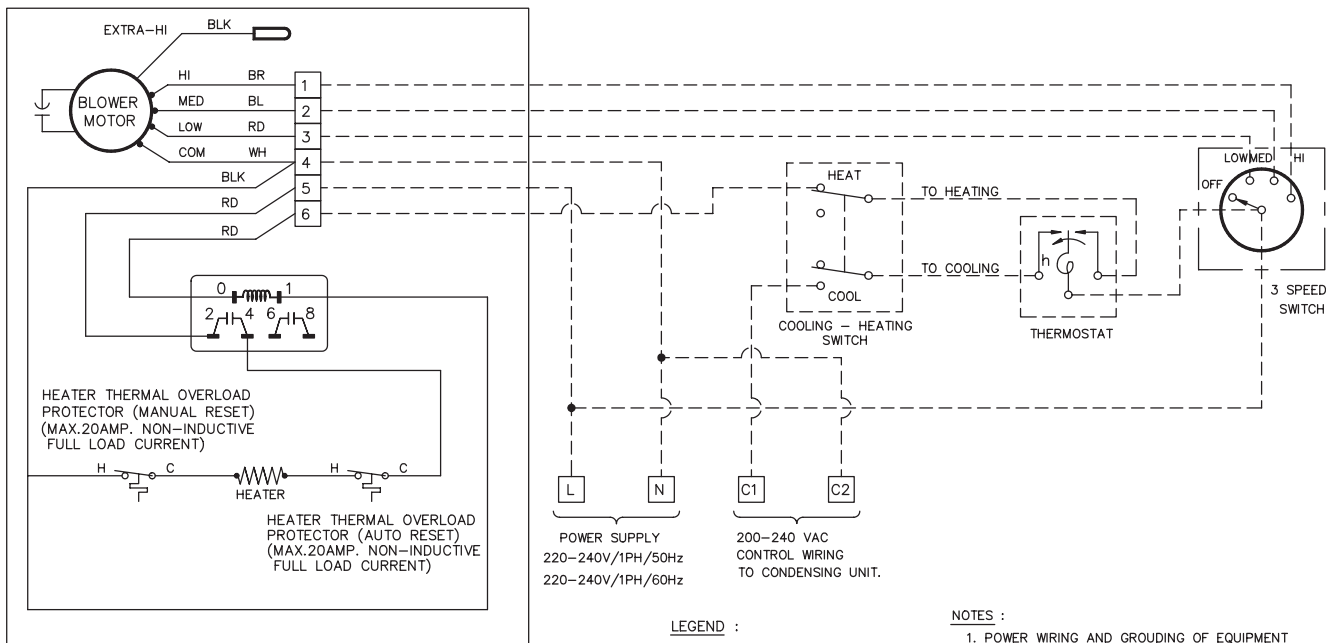

**LEGEND :**

- FIELD WIRING
- FACTORY WIRING

**NOTES :**

1. POWER WIRING AND GROUNDING OF EQUIPMENT MUST COMPLY WITH LOCAL CODES.
2. ENSURE THAT POWER SUPPLY AGREES WITH EQUIPMENT NAME PLATE.
3. USE ONLY COPPER CONDUCTORS.

# MCD Wiring Diagram

## COOLING HEATING MCDA30-36DB MCDB42-60DB

Remove HI-BR wire FROM TB-1 and replace with EXTRA HI-BLK wire when high speed/cfm is required in the field.

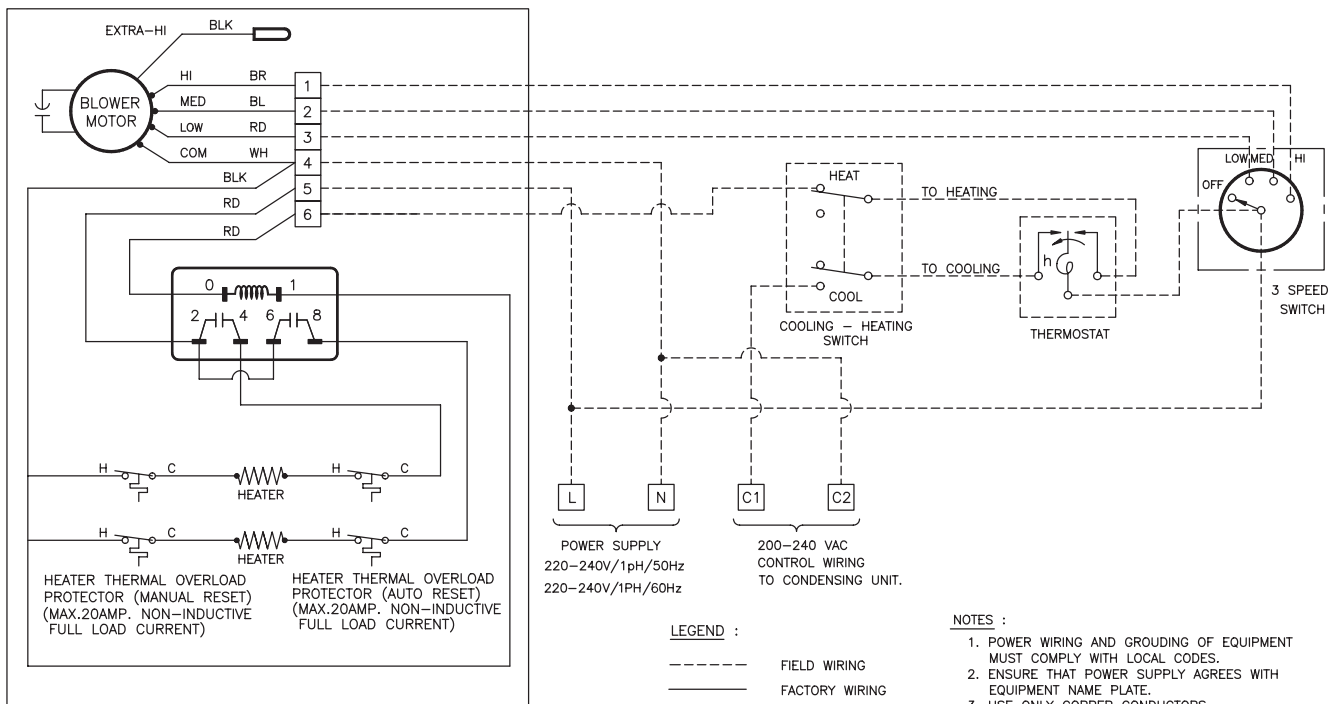

# WIRING DIAGRAM LCD CONTROL SERIES : COOLING ONLY

1. FREEZE SENSOR LOCATED ON EVAPORATOR COIL (OPTION)
2. TEMPERATURE SENSOR LOCATED IN RETURN AIR STREAM

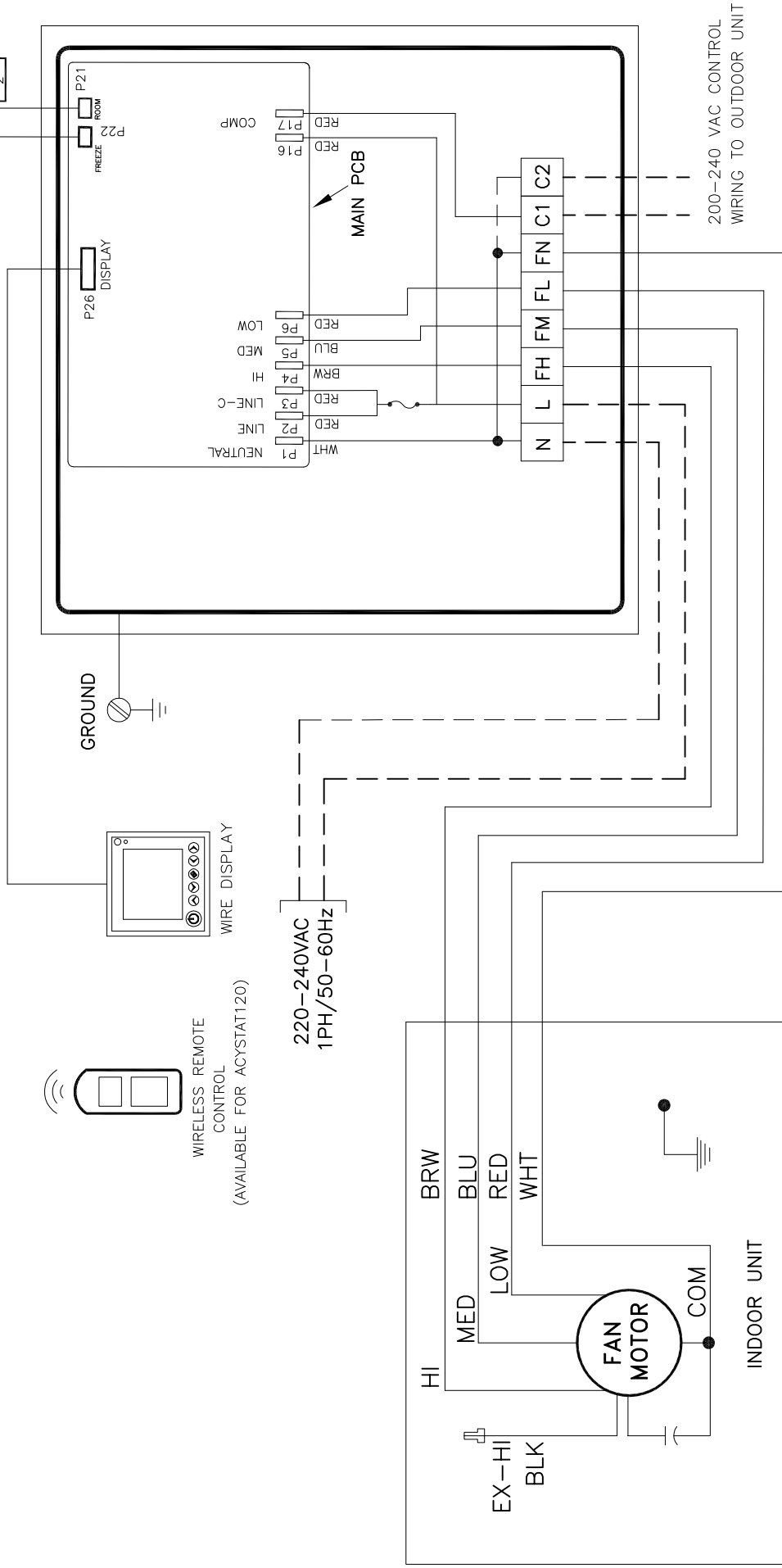

## NOTES :

1. Power wiring and grounding of equipment must comply with local codes.
2. Ensure that power supply agrees with equipment nameplate.
3. Use only copper conductors.
4. Total fan motor running amperes must not exceed 2.25 AMPS.
5. Total amperes must not exceed 5.0 AMPS. (resistive)  
2.25 AMPS. (inductive)

ACYSTAT110  
ACYSTAT120

# WIRING DIAGRAM TOUCH CONTROL SERIES : COOLING ONLY

1. FREEZE SENSOR LOCATED ON EVAPORATOR COIL
2. TEMPERATURE SENSOR LOCATED IN RETURN AIR STREAM

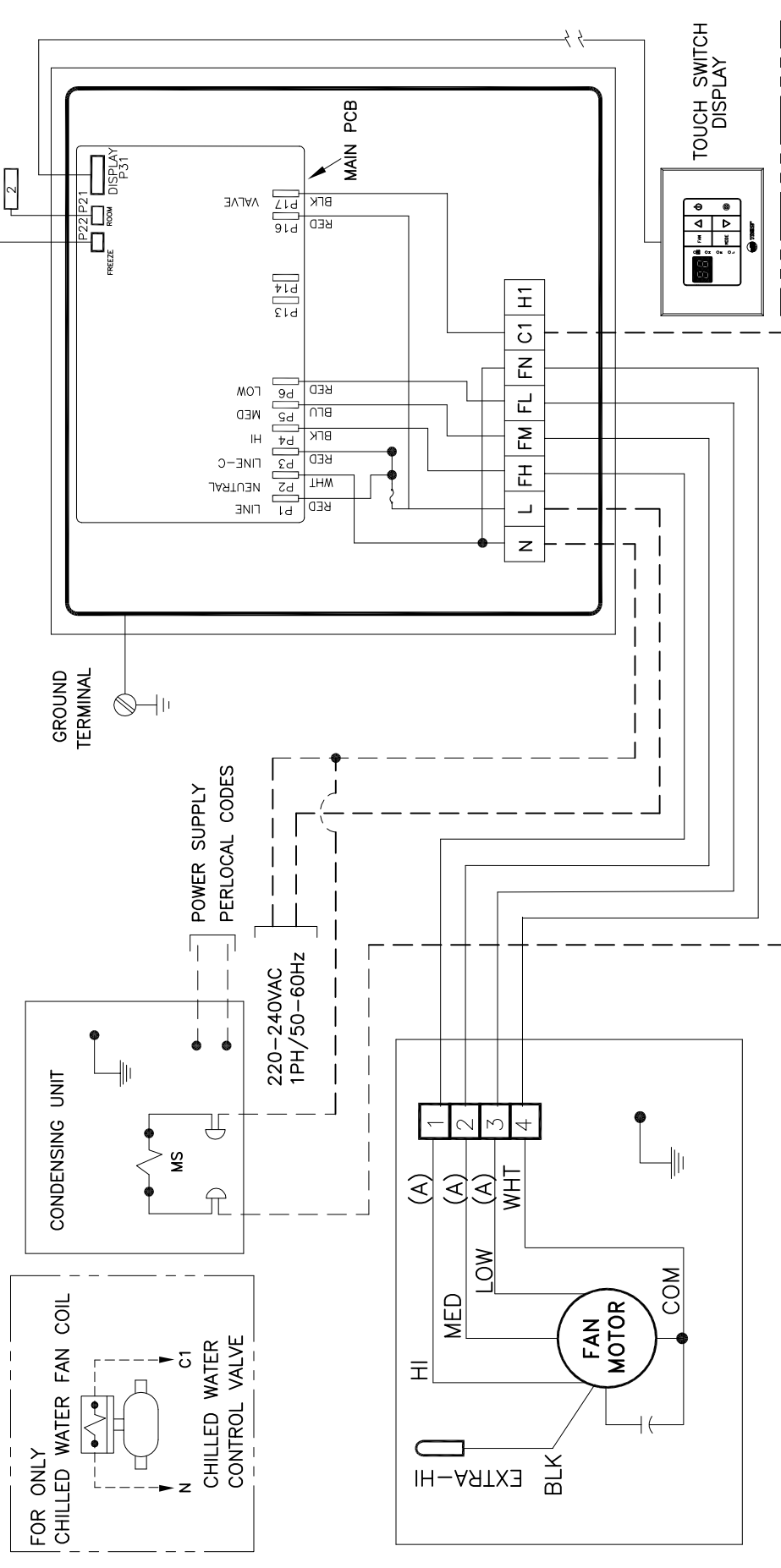

**(A) DETAILS(MOTOR WIRE COLORS)**

MODELS	HI	MED	LOW
3 SPEED*	BLACK	BLUE	RED
4 SPEED	BROWN	BLUE	RED

\*EXTRA-HI is unavailable for 3 speed models.

**NOTES :**

1. Power wiring and grounding of equipment must comply with local codes.
2. Ensure that power supply agrees with equipment nameplate.
3. Use only copper conductors.

4. Total fan motor running amperes must not exceed 5 AMPS.
5. In each terminal, total amperes must not exceed  
10 AMPS. (resistive)  
5 AMPS. (inductive)

\*REMOTE CONTROL COOLING ONLY FOR WIRELESS MODEL ONLY ACYSTAT170AA

LEGEND :  
 FACTORY WIRING  
 FIELD WIRING

ACYSTAT160AA/AB  
ACYSTAT170AA/AB

# WIRING DIAGRAM LCD CONTROL SERIES : COOLING&HEATING

- 1. FREEZE SENSOR LOCATED ON EVAPORATOR COIL
- 2. TEMPERATURE SENSOR LOCATED IN RETURN AIR STREAM

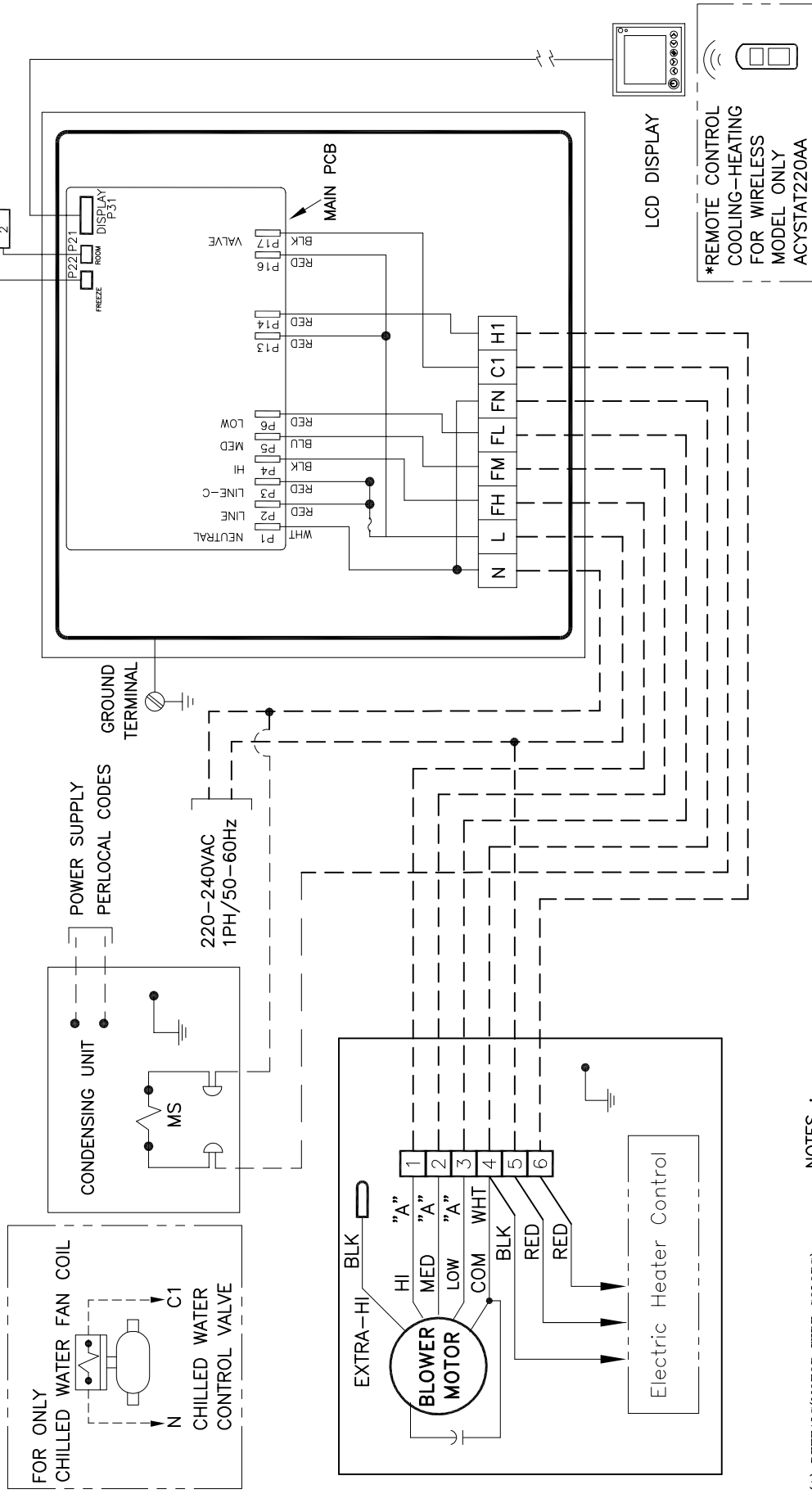

(A) DETAILS(MOTOR WIRE COLORS)

MODELS	HI	MED	LOW
3 SPEED*	BLACK	BLUE	RED
4 SPEED	BROWN	BLUE	RED

\*EXTRA-HI is unavailable for 3 speed models.

**NOTES :**

1. Power wiring and grounding of equipment must comply with local codes.
2. Ensure that power supply agrees with equipment nameplate.
3. Use only copper conductors.
4. Total fan motor running amperes must not exceed 5 AMPS.
5. In each terminal, total amperes must not exceed 10 AMPS. (resistive)  
5 AMPS. (inductive)

**LEGEND :**

- FACTORY WIRING
- - - - - FIELD WIRING

# WIRING DIAGRAM DIGITAL THERMOSTAT CONTROL : COOLING-HEATING

1. FREEZE SENSOR LOCATED ON EVAPORATOR COIL
2. TEMPERATURE SENSOR LOCATED IN RETURN AIR STREAM

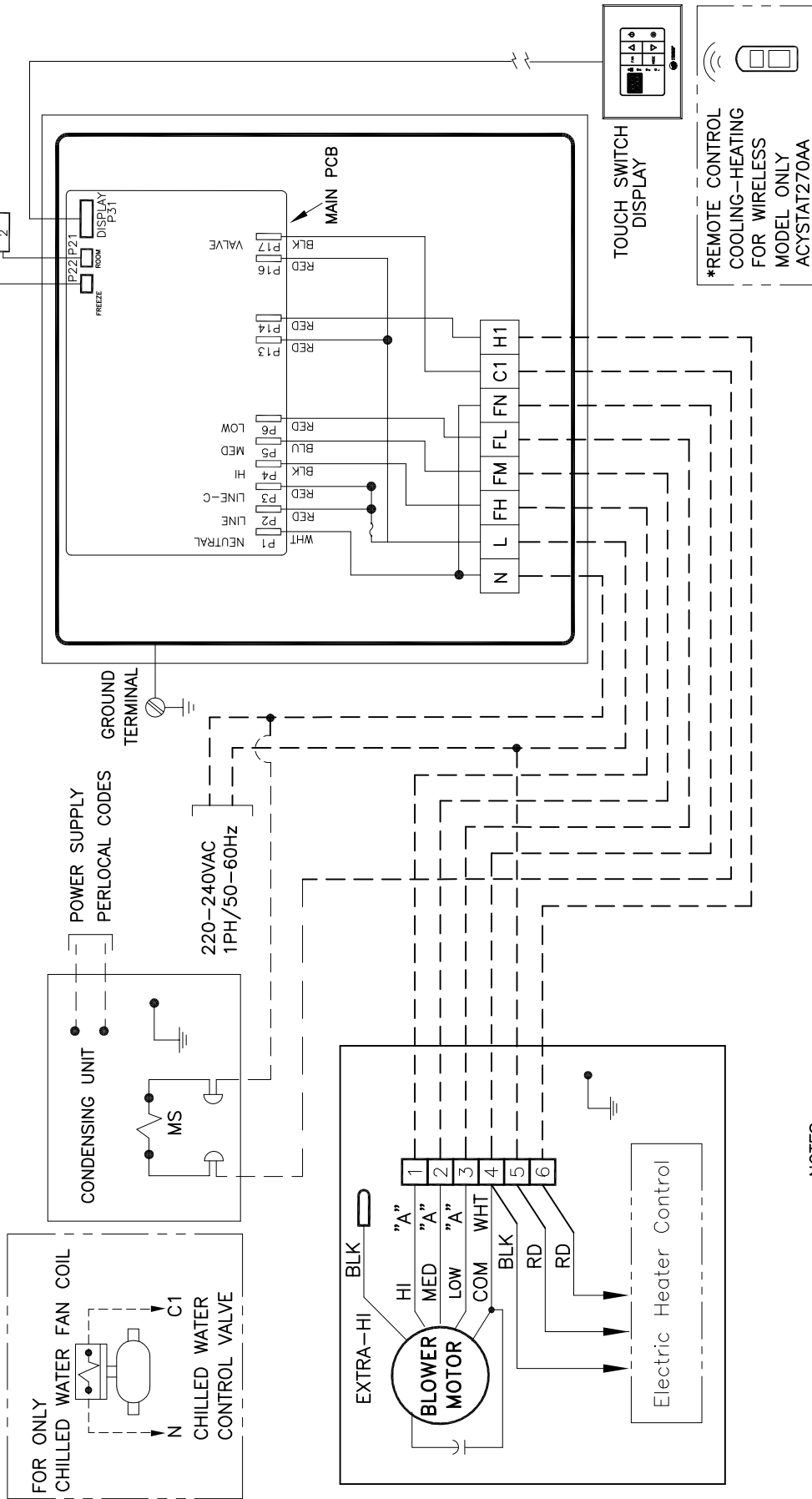

**NOTES :**

1. Power wiring and grounding of equipment must comply with local codes.
2. Ensure that power supply agrees with equipment nameplate.
3. Use only copper conductors.
4. Total fan motor running amperes must not exceed 5 AMPS.
5. In each terminal, total amperes must not exceed  
 10 AMPS. (resistive)  
 5 AMPS. (inductive)

(A) DETAILS(MOTOR WIRE COLORS)

MODELS	HI	MED	LOW
3 SPEED*	BLACK	BLUE	RED
4 SPEED	BROWN	BLUE	RED

\*EXTRA-HI is unavailable for 3 speed models.

LEGEND :  
 \_\_\_\_\_ FACTORY WIRING  
 - - - - - FIELD WIRING

# Electrical Data

## Schematic Diagrams

4TTB3018, 4TTB3024, 4TTB3030, 4TTB 3036

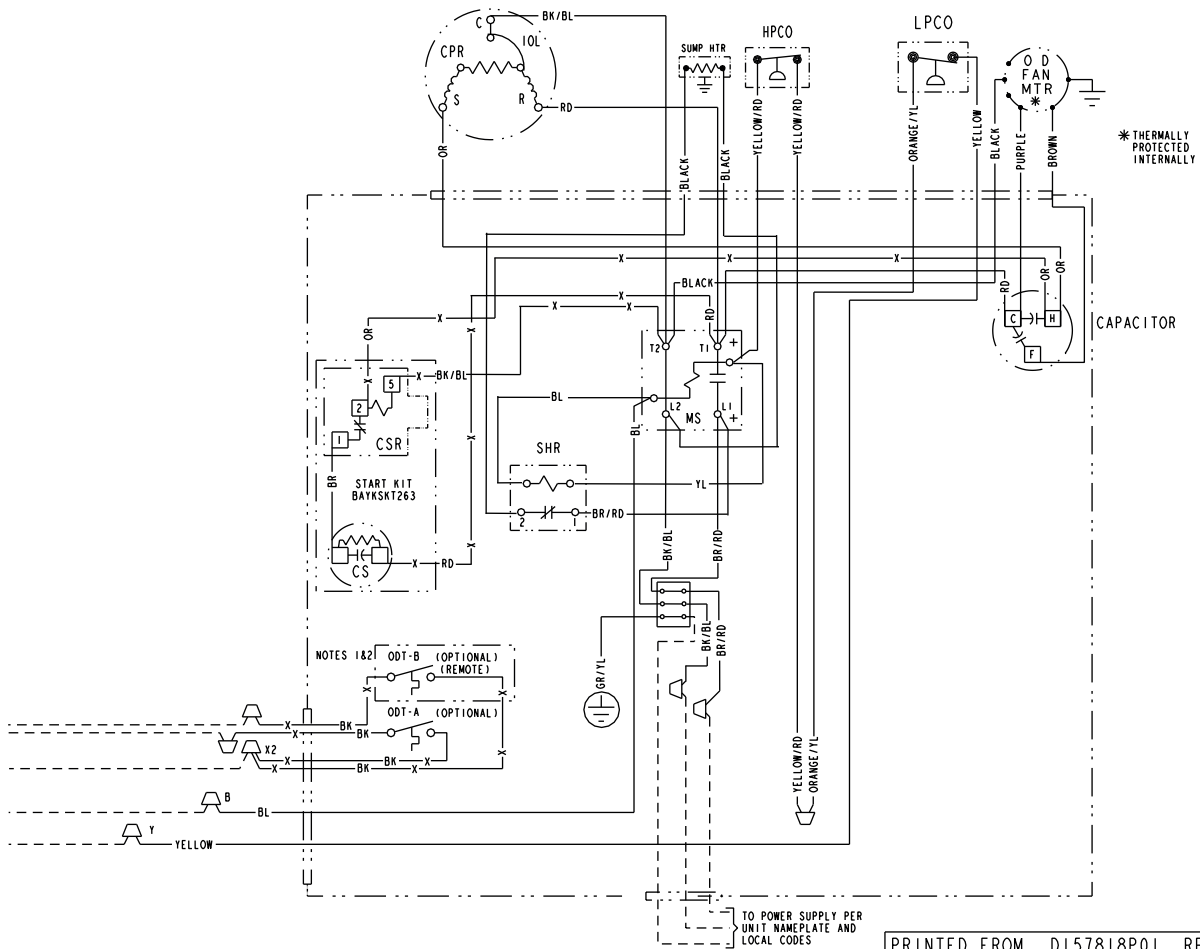

PRINTED FROM D157818P01 REV00

COLOR OF WIRE		
BK/BL	BLACK WIRE WITH BLUE MARKER	
COLOR OF MARKER		
BK	OR	YL
BL	RD	GR
BR	WH	PR

CA	COOLING ANTICIPATOR	LPCO	LOW PRESSURE CUTOFF SW.
CBS	COIL BOTTOM SENSOR	MS	COMPRESSOR MOTOR CONTACTOR
CF	FAN CAPACITOR	ODA	OUTDOOR ANTICIPATOR
CN	WIRE CONNECTOR	OFT	OUTDOOR FAN THERMOSTAT
CPR	COMPRESSOR	ODS	OUTDOOR TEMPERATURE SENSOR
CR	RUN CAPACITOR	ODT	OUTDOOR THERMOSTAT
CS	STARTING CAPACITOR	RHS	RESISTANCE HEAT SWITCH
CSR	CAPACITOR SWITCHING RELAY	SC	SWITCHOVER VALVE SOLENOID
DFC	DEFROST CONTROL	SM	SYSTEM "ON-OFF" SWITCH
F	INDOOR FAN RELAY	TDL	DISCHARGE LINE THERMOSTAT
HA	HEATING ANTICIPATOR	TNS	TRANSFORMER
HPCO	HIGH PRESSURE CUTOFF SW.	TS	HEATING-COOLING THERMOSTAT
IOL	INTERNAL OVERLOAD PROTECTOR	TSH	HEATING THERMOSTAT
ACR	A/C RECTIFIER	R	SHUNT RESISTOR
		SHR	SUMP HEATER RELAY

<p><b>⚠ WARNING</b> HAZARDOUS VOLTAGE! DISCONNECT ALL ELECTRIC POWER INCLUDING REMOTE DISCONNECTS BEFORE SERVICING. FAILURE TO DISCONNECT POWER BEFORE SERVICING CAN CAUSE SEVERE PERSONAL INJURY OR DEATH!</p>	<p><b>⚠ CAUTION</b> USE COPPER CONDUCTORS ONLY! UNIT TERMINALS ARE NOT DESIGNED TO ACCEPT OTHER TYPES OF CONDUCTORS. FAILURE TO DO SO MAY CAUSE DAMAGE TO THE EQUIPMENT!</p>
---	--



# Electrical Data

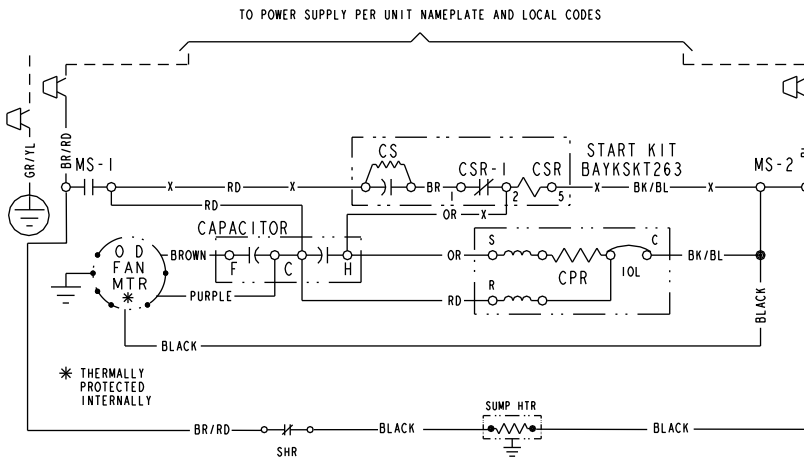

CA COOLING ANTICIPATOR	LPCO LOW PRESSURE CUTOFF SW.
CBS COIL BOTTOM SENSOR	MS COMPRESSOR MOTOR CONTACTOR
CF FAN CAPACITOR	ODA OUTDOOR ANTICIPATOR
CN WIRE CONNECTOR	OFT OUTDOOR FAN THERMOSTAT
CPR COMPRESSOR	ODS OUTDOOR TEMPERATURE SENSOR
CR RUN CAPACITOR	ODT OUTDOOR THERMOSTAT
CS STARTING CAPACITOR	RHS RESISTANCE HEAT SWITCH
CSR CAPACITOR SWITCHING RELAY	SC SWITCHOVER VALVE SOLENOID
DFC DEFROST CONTROL	SM SYSTEM "ON-OFF" SWITCH
F INDOOR FAN RELAY	TDL DISCHARGE LINE THERMOSTAT
HA HEATING ANTICIPATOR	TNS TRANSFORMER
HPCO HIGH PRESSURE CUTOFF SW.	TS HEATING-COOLING THERMOSTAT
IOL INTERNAL OVERLOAD PROTECTOR	TSH HEATING THERMOSTAT
ACR A/C RECTIFIER	R OFT SHUNT RESISTOR
	SHR SUMP HEATER RELAY

<p><b>⚠ WARNING</b></p> <p>HAZARDOUS VOLTAGE!</p> <p>DISCONNECT ALL ELECTRIC POWER INCLUDING REMOTE DISCONNECTS BEFORE SERVICING.</p> <p>FAILURE TO DISCONNECT POWER BEFORE SERVICING CAN CAUSE SEVERE PERSONAL INJURY OR DEATH!</p>	<p><b>⚠ CAUTION</b></p> <p>USE COPPER CONDUCTORS ONLY!</p> <p>UNIT TERMINALS ARE NOT DESIGNED TO ACCEPT OTHER TYPES OF CONDUCTORS.</p> <p>FAILURE TO DO SO MAY CAUSE DAMAGE TO THE EQUIPMENT!</p>
--	---

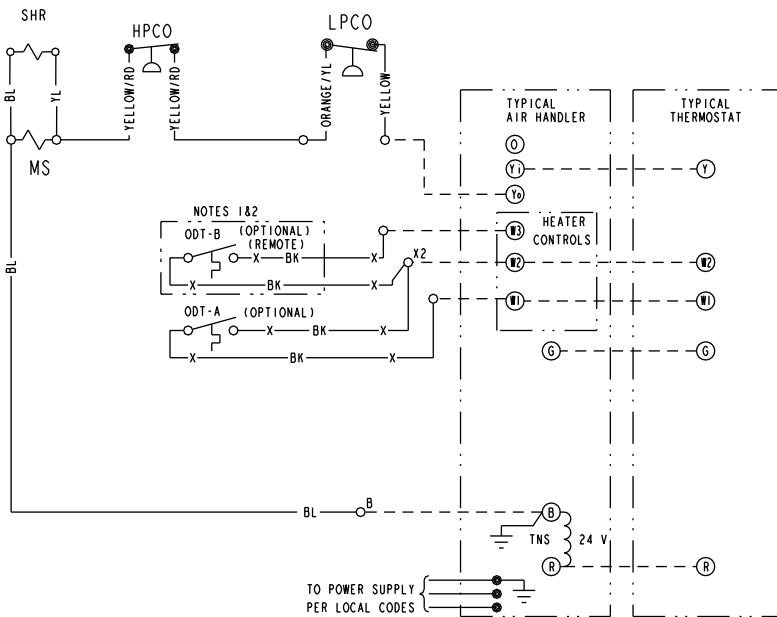

COLOR OF WIRE			
BK/BL	BLACK WIRE WITH BLUE MARKER		
COLOR OF MARKER			
BK	BL	OR	RD
OR	RD	YL	GR
YL	GR	PR	
PR			

**NOTES:**

- IF ODT-B IS NOT USED, ADD JUMPER BETWEEN W2 & W3 AT AIR HANDLER. IF USED, ODT-B MUST BE MOUNTED REMOTE OF CONTROL BOX IN AN APPROVED WEATHER PROOF ENCLOSURE.
- IF ODT-A IS NOT USED, ADD JUMPER BETWEEN W1 & W2 AT AIR HANDLER.
- LOW VOLTAGE (24 V.) FIELD WIRING MUST BE 18 AWG MIN.

FOR CANADIAN INSTALLATIONS  
POUR INSTALLATIONS CANADIENNES

CAUTION: NOT SUITABLE FOR USE ON SYSTEMS EXCEEDING 150V-TO-GROUND.  
ATTENTION: NE CONVIENT PAS AUX INSTALLATIONS DE PLUS DE 150 V A LA TERRE.

PRINTED FROM D157818P01 REV00

# Electrical Data

## Schematic Diagrams

4TTA3030AD, 4TTA3036AD, 4TTA3042AD,  
4TTA3048AD, 4TTA3060AD

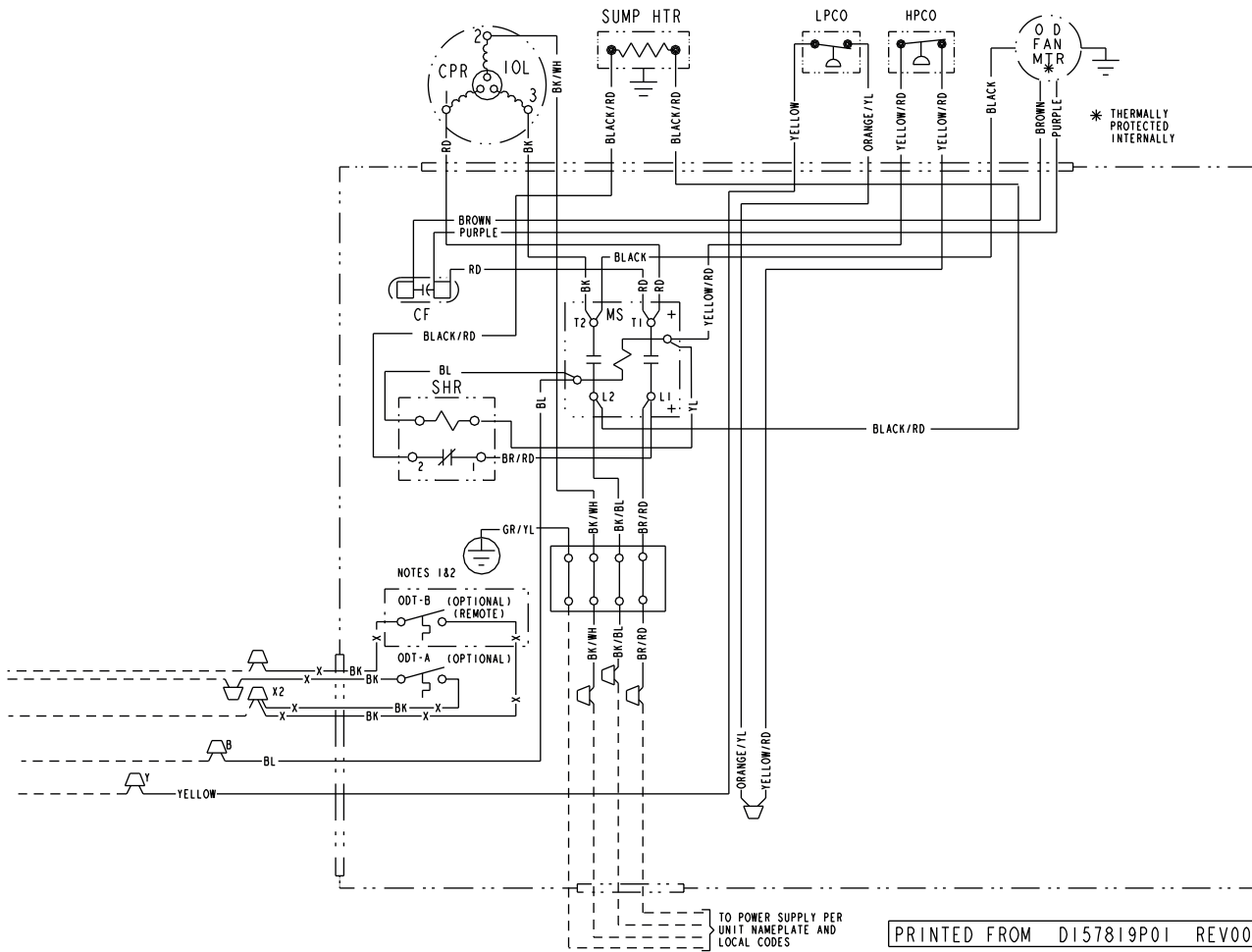

PRINTED FROM DI57819P01 REV00

COLOR OF WIRE			
BK/BL	BLACK WIRE WITH BLUE MARKER		
COLOR OF MARKER			
BK	BLACK	OR	ORANGE
BL	BLUE	RD	RED
BR	BROWN	WH	WHITE
YL	YELLOW	GR	GREEN
PR	PURPLE		

CA	COOLING ANTICIPATOR
CBS	COIL BOTTOM SENSOR
CF	FAN CAPACITOR
CN	WIRE CONNECTOR
CPR	COMPRESSOR
CR	RUN CAPACITOR
CS	STARTING CAPACITOR
CSR	CAPACITOR SWITCHING RELAY
DFC	DEFROST CONTROL
F	INDOOR FAN RELAY
HA	HEATING ANTICIPATOR
HPCO	HIGH PRESSURE CUTOUT SW.
IOL	INTERNAL OVERLOAD PROTECTOR

LPCO	LOW PRESSURE CUTOUT SW.
MS	COMPRESSOR MOTOR CONTACTOR
ODA	OUTDOOR ANTICIPATOR
OFT	OUTDOOR FAN THERMOSTAT
ODS	OUTDOOR TEMPERATURE SENSOR
ODT	OUTDOOR THERMOSTAT
RHS	RESISTANCE HEAT SWITCH
SC	SWITCHOVER VALVE SOLENOID
SHR	SUMP HEAT RELAY
SM	SYSTEM "ON-OFF" SWITCH
TDL	DISCHARGE LINE THERMOSTAT
TNS	TRANSFORMER
TS	HEATING-COOLING THERMOSTAT
TSH	HEATING THERMOSTAT
SHR	SUMP HEATER RELAY

<p><b>⚠ WARNING</b> HAZARDOUS VOLTAGE! DISCONNECT ALL ELECTRIC POWER INCLUDING REMOTE BEFORE SERVICING.</p> <p>FAILURE TO DISCONNECT POWER BEFORE SERVICING CAN CAUSE SEVERE PERSONAL INJURY OR DEATH!</p>	<p><b>⚠ CAUTION</b> UNIT TERMINALS ARE NOT DESIGNED TO ACCEPT OTHER TYPES OF CONDUCTORS. FAILURE TO DO SO MAY CAUSE DAMAGE TO THE EQUIPMENT!</p>
--	--

# Electrical Data

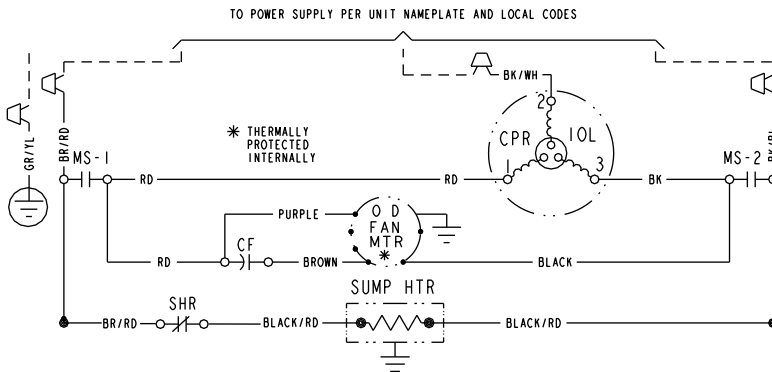

CA COOLING ANTICIPATOR	LPCO LOW PRESSURE CUTOUT SW.
CBS COIL BOTTOM SENSOR	MS COMPRESSOR MOTOR CONTACTOR
CF FAN CAPACITOR	ODA OUTDOOR ANTICIPATOR
CN WIRE CONNECTOR	OFT OUTDOOR FAN THERMOSTAT
CPR COMPRESSOR	ODS OUTDOOR TEMPERATURE SENSOR
CR RUN CAPACITOR	ODT OUTDOOR THERMOSTAT
CS STARTING CAPACITOR	RHS RESISTANCE HEAT SWITCH
CSR CAPACITOR SWITCHING RELAY	SC SWITCHOVER VALVE SOLENOID
DFC DEFROST CONTROL	SHR SUMP HEAT RELAY
F INDOOR FAN RELAY	SM SYSTEM "ON-OFF" SWITCH
HA HEATING ANTICIPATOR	TDL DISCHARGE LINE THERMOSTAT
HPCO HIGH PRESSURE CUTOUT SW.	TNS TRANSFORMER
IOL INTERNAL OVERLOAD PROTECTOR	TS HEATING-COOLING THERMOSTAT
	TSH HEATING THERMOSTAT
	SHR SUMP HEATER RELAY

<p><b>⚠ WARNING</b> HAZARDOUS VOLTAGE! DISCONNECT ALL ELECTRIC POWER INCLUDING REMOTE BEFORE SERVICING. FAILURE TO DISCONNECT POWER BEFORE SERVICING CAN CAUSE SEVERE PERSONAL INJURY OR DEATH!</p>	<p><b>⚠ CAUTION</b> USE COPPER CONDUCTORS ONLY! UNIT TERMINALS ARE NOT DESIGNED TO ACCEPT OTHER TYPES OF CONDUCTORS. FAILURE TO DO SO MAY CAUSE DAMAGE TO THE EQUIPMENT!</p>
---	--

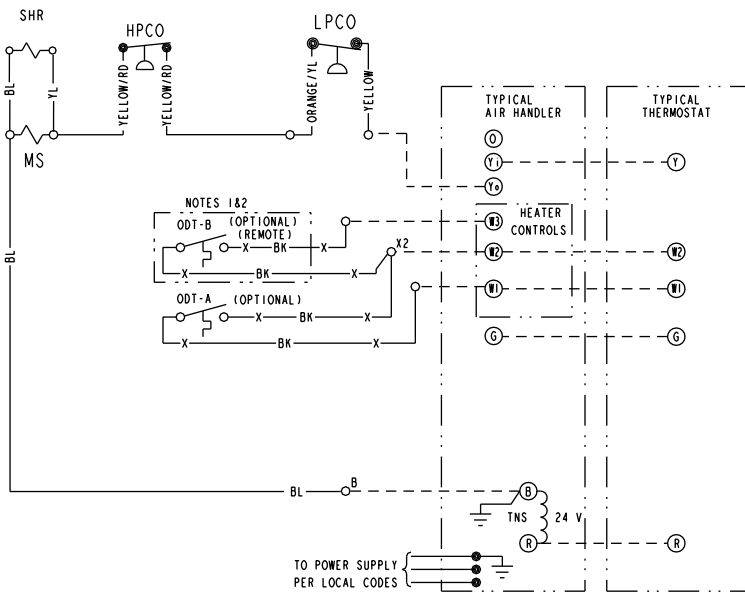

BR/BL	COLOR OF WIRE	BK/WH	BLACK WIRE WITH BLUE MARKER
BK	BLACK	OR	ORANGE
BL	BLUE	RD	RED
BR	BROWN	WH	WHITE
		YL	YELLOW
		GR	GREEN
		PR	PURPLE

**NOTES:**

- IF ODT-B IS NOT USED, ADD JUMPER BETWEEN W2 & W3 AT AIR HANDLER.  
IF USED, ODT-B MUST BE MOUNTED REMOTE OF CONTROL BOX IN AN APPROVED WEATHER PROOF ENCLOSURE.
- IF ODT-A IS NOT USED, ADD JUMPER BETWEEN W1 & W2 AT AIR HANDLER.
- LOW VOLTAGE (24 V.) FIELD WIRING MUST BE 18 AWG MIN.

**NOTE**  
THREE PHASE MOTOR (S) FACTORY SUPPLIED IN THIS EQUIPMENT PROTECTED UNDER PRIMARY SINGLE-PHASE CONDITIONS.

PRINTED FROM D157819P01 REV00

# Electrical Data

## 4TTB / 4TTA / MCD

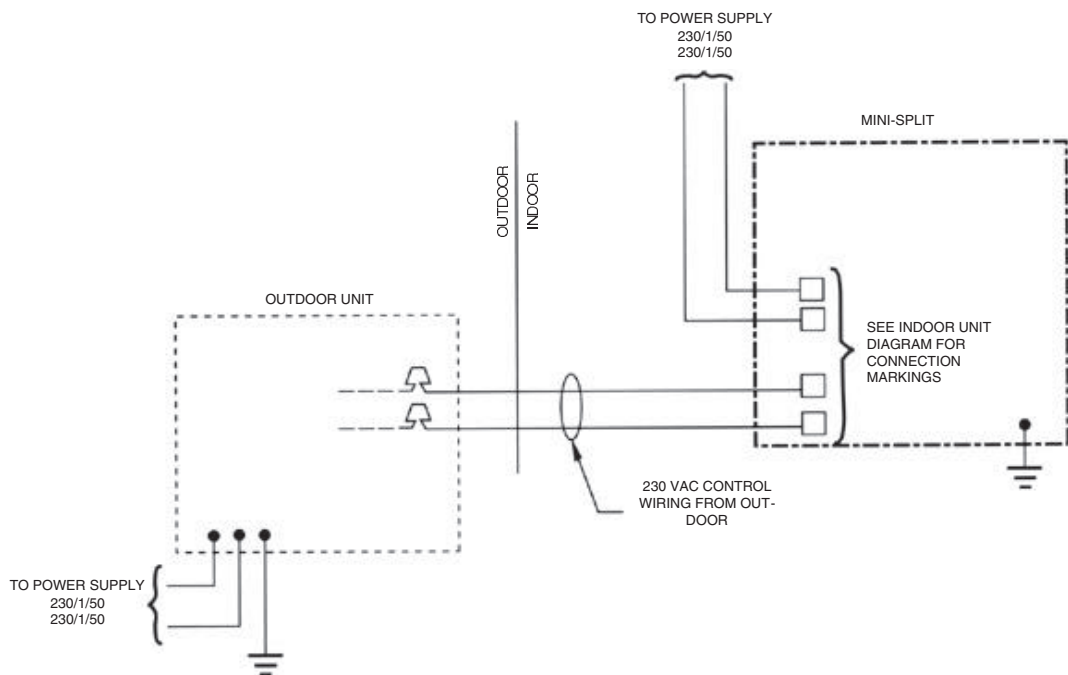

**NOTES :**

1. POWER WIRING AND GROUNDING OF EQUIPMENT MUST COMPLY WITH LOCAL CODES.
2. INSURE THAT POWER SUPPLY AGREES WITH EQUIPMENT NAME PLATE.
3. USE ONLY COPPER CONDUCTORS.

# MCD Dimensional Data

## OUTLINE DIMENSION MCDA18-536DB

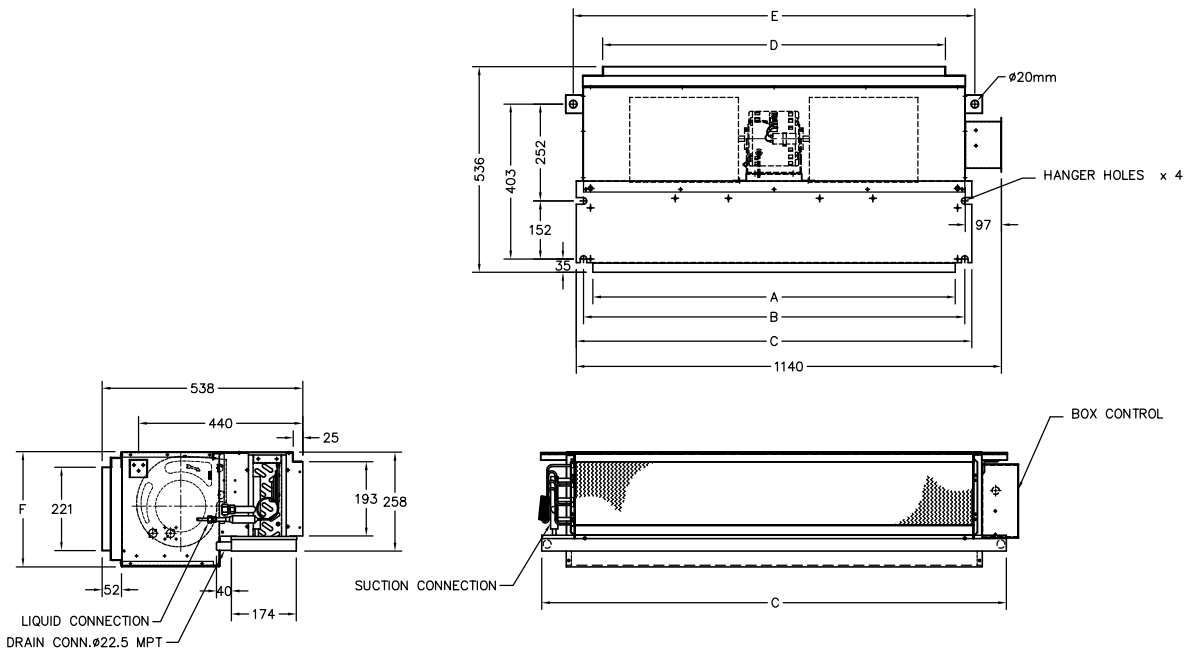

Model	All External Dimensions are in inch (mm)						Refrig. Line Conn. Size		Number Of	
	A	B	C	D	E	F	Suction	Liquid	Fan (s)	Motor (s)
MCDA18DBPHAA	38 1/4"(972)	40 1/4"(1022)	41 3/4"(1060)	36"(919)	42 3/8"(1077)	12" (304)	5/8"(15.87)	3/8"(9.53)	2	1
MCDA24DBPHAA	38 1/4"(972)	40 1/4"(1022)	41 3/4"(1060)	36"(919)	42 3/8"(1077)	12" (304)	5/8"(15.87)	3/8"(9.53)	2	1

Model	All External Dimensions are in inch (mm)										
	A	B	C	D	E	F	G	H	I	J	K
MCDA30DBPHAA	42 1/16"(1069)	46 3/4"(1187)	49 1/4"(1251)	39 5/8"(1005)	45 7/8"(1166)	14"(354)	15 1/2"(394)	22 11/16"(577)	28 1/2"(724)	10 1/8"(257)	6 1/2"(165)
MCDA36DBPHAA	36 1/16"(916)	40 3/4"(1034)	43 1/4"(1098)	33 1/2"(851)	39 7/8"(1013)	14"(354)	15 1/2"(394)	24 1/4"(615)	29 7/8"(759)	16 1/16"(408)	13 7/8"(352)

Refrig. Line Conn. Size ( SWEAT TYPE )		Refrig. Line Conn. Size ( FLARE TYPE )		Number Of	
Suction	Liquid	Suction	Liquid	Fan(s)	Motor(s)
-	-	3/4"(19.05)	3/8"(9.53)	2	1
-	-	7/8"(22.23)	3/8"(9.53)	2	1

# MCD Dimensional Data

## OUTLINE DIMENSION MCDB42-60DB

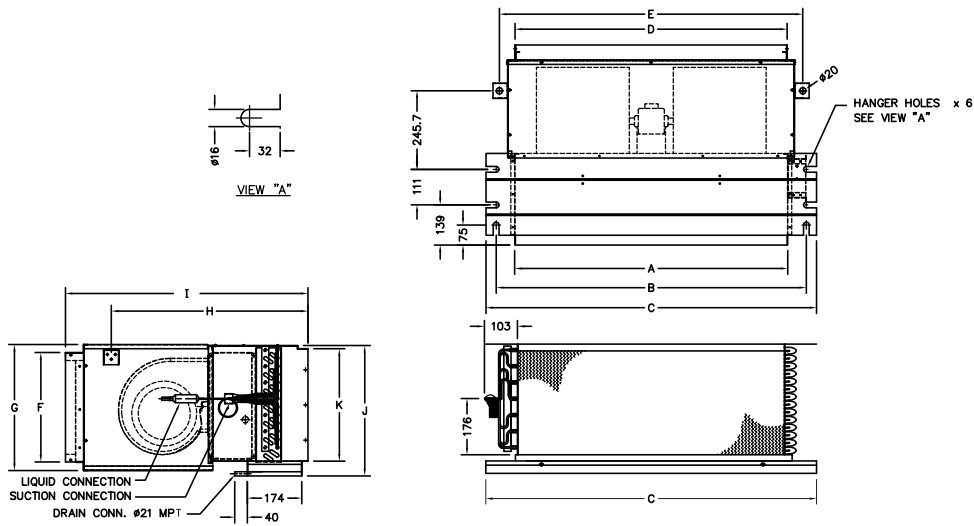

Model	All External Dimensions are in inch (mm)										
	A	B	C	D	E	F	G	H	I	J	K
MCDB42DBPHAA	36 1/16"(916)	40 3/4"(1034)	43 1/4"(1098)	33 1/2"(851)	39 7/8"(1013)	14"(354)	15 1/2"(394)	24 1/4"(615)	29 7/8"(759)	16 1/16"(408)	13 7/8"(352)
MCDB48DBPHAA	42 1/16"(1069)	46 3/4"(1187)	49 1/4"(1251)	39 5/8"(1005)	45 7/8"(1166)	14"(354)	15 1/2"(394)	24 1/4"(615)	29 7/8"(759)	16 1/16"(408)	13 7/8"(352)
MCDB60DBPHAA	42 1/16"(1069)	46 3/4"(1187)	49 1/4"(1251)	39 5/8"(1005)	45 7/8"(1166)	14"(354)	15 1/2"(394)	24 1/4"(615)	29 7/8"(759)	16 1/16"(408)	13 7/8"(352)

Refrig. Line Conn. Size ( SWEAT TYPE )		Refrig. Line Conn. Size ( FLARE TYPE )		Number Of	
Suction	Liquid	Suction	Liquid	Fan(s)	Motor(s)
7/8"(22.23)	3/8"(9.53)	-	-	2	1
7/8"(22.23)	3/8"(9.53)	-	-	2	1
7/8"(22.23)	3/8"(9.53)	-	-	2	1

# Dimensions

## 4TTB3 Outline Drawing

Note: All dimensions are in MM (Inches).

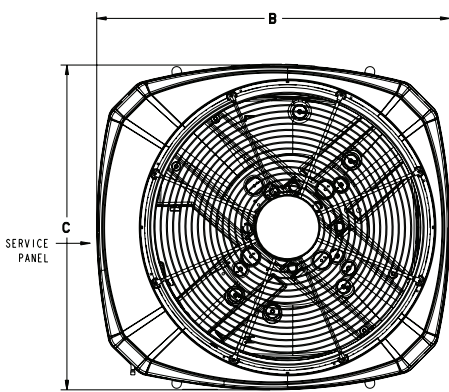

ELECTRICAL AND REFRIGERANT COMPONENT CLEARANCES PER PREVAILING CODES.

TOP DISCHARGE AREA SHOULD BE UNRESTRICTED FOR AT LEAST 1524 (5 FEET) ABOVE UNIT. UNIT SHOULD BE PLACED SO ROOF RUN-OFF WATER DOES NOT POUR DIRECTLY ON UNIT, AND SHOULD BE AT LEAST 305 (12") FROM WALL AND ALL SURROUNDING SHRUBBERY ON TWO SIDES, OTHER TWO SIDES UNRESTRICTED.

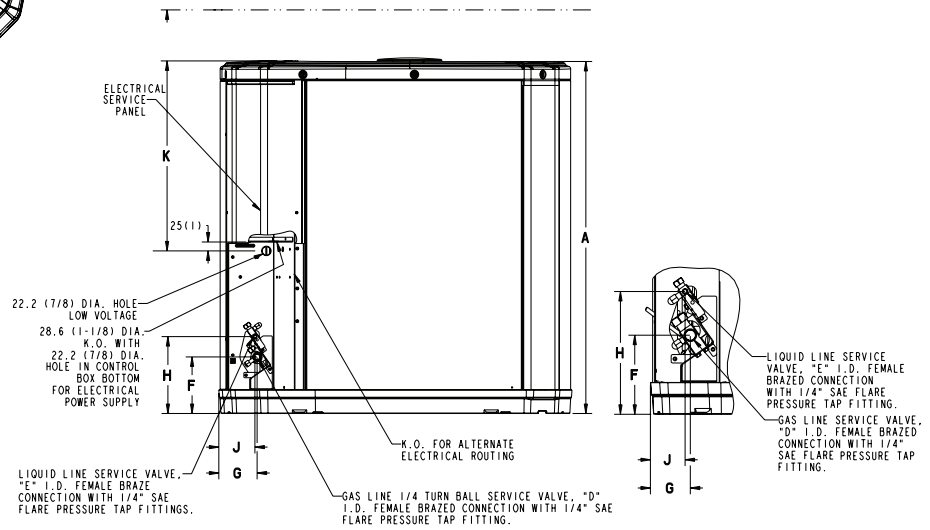

MODELS	BASE	A	B	C	D	E	F	G	H	J	K
4TTB3018A	3	730 (28-3/4)	829 (32-5/8)	756 (29-3/4)	3/4	3/8	127 (5)	76 (3)	197 (7-3/4)	57 (2-1/4)	508 (20)
4TTB3024A	3	730 (28-3/4)	829 (32-5/8)	756 (29-3/4)	3/4	3/8	127 (5)	76 (3)	197 (7-3/4)	57 (2-1/4)	508 (20)
4TTB3030A	4	943 (37-1/8)	946 (37-1/4)	870 (34-1/4)	3/4	3/8	152 (6)	98 (3-7/8)	219 (8-5/8)	86 (3-3/8)	508 (20)
4TTB3036A	4	943 (37-1/8)	946 (37-1/4)	870 (34-1/4)	7/8	3/8	152 (6)	98 (3-7/8)	219 (8-5/8)	86 (3-3/8)	508 (20)

# Dimensions

## 4TTA3 Outline Drawing

Note : All dimensions are in MM (Inches)

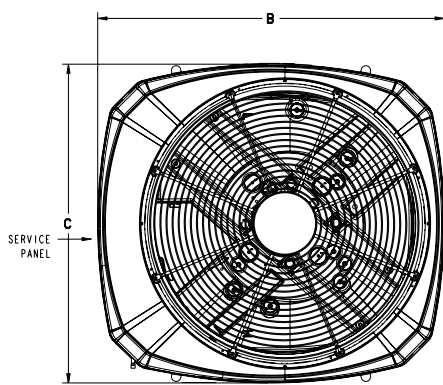

TOP DISCHARGE AREA SHOULD BE UNRESTRICTED FOR AT LEAST 1524 (5 FEET) ABOVE UNIT. UNIT SHOULD BE PLACED SO ROOF RUN-OFF WATER DOES NOT POUR DIRECTLY ON UNIT, AND SHOULD BE AT LEAST 305 (12") FROM WALL AND ALL SURROUNDING SHRUBBERY ON TWO SIDES. OTHER TWO SIDES UNRESTRICTED.

ELECTRICAL AND REFRIGERANT COMPONENT CLEARANCES PER PREVAILING CODES.

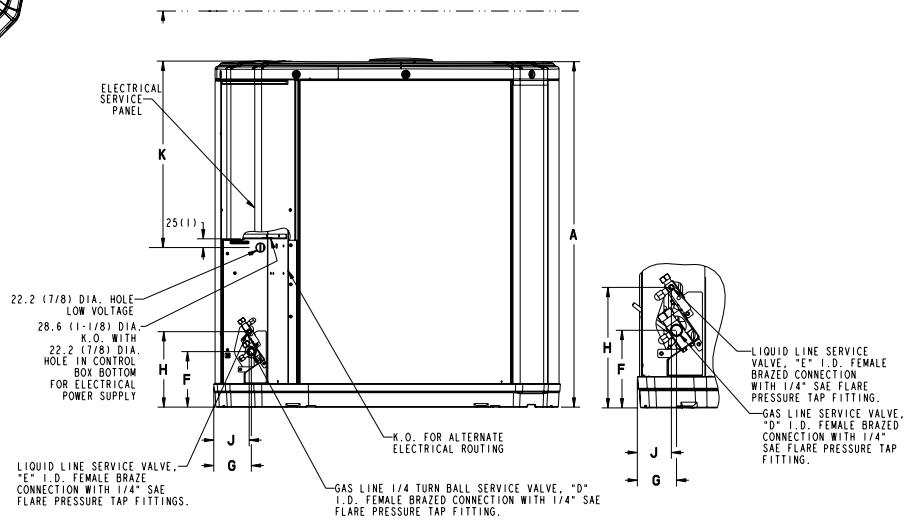

MODELS	BASE	A	B	C	D	E	F	G	H	J	K
4TTA3030A	4	943 (37-1/8)	946 (37-1/4)	870 (34-1/4)	3/4	3/8	152 (6)	98 (3-7/8)	219 (8-5/8)	86 (3-3/8)	508 (20)
4TTA3036A	4	943 (37-1/8)	946 (37-1/4)	870 (34-1/4)	7/8	3/8	152 (6)	98 (3-7/8)	219 (8-5/8)	86 (3-3/8)	508 (20)
4TTA3042A	4	1045 (41-1/8)	946 (37-1/4)	870 (34-1/4)	7/8	3/8	152 (6)	98 (3-7/8)	219 (8-5/8)	86 (3-3/8)	508 (20)
4TTA3048A	4	1147 (45-1/8)	946 (37-1/4)	870 (34-1/4)	7/8	3/8	152 (6)	98 (3-7/8)	219 (8-5/8)	86 (3-3/8)	508 (20)
4TTA3060A	4	1147 (45-1/8)	946 (37-1/4)	870 (34-1/4)	7/8	3/8	152 (6)	98 (3-7/8)	219 (8-5/8)	86 (3-3/8)	508 (20)





# Mechanical Specifications - 4TTB

---

## General

The 4TTB3 is fully charged from the factory for up to 25 feet of piping. This unit is designed to operate at outdoor ambient temperatures as high as 125°F. Cooling capacities are matched with a wide selection of air handlers and furnace coils that are **tested in accordance to AHRI and UL 1995.**

## Casing

Unit casing is constructed of heavy gauge, G90 galvanized steel and painted with a weather-resistant powder paint on all louvers, panels, pre-paint on all other panels. Corrosion and weatherproof CMBP-G30 DuraTuff™ base.

## Refrigerant Controls

Refrigeration system controls include condenser fan and compressor contactor. High and low pressure controls are inherent to the compressor. Liquid line drier is shipped separately with the unit for field installation.

## Compressor

The Scroll compressor features internal over temperature and pressure protection and total dipped hermetic motor and thermostatically controlled sump/ crankcase heater. Other features include: centrifugal oil pump and low vibration and noise.

## Condenser Coil

The outdoor coil provides low airflow resistance and efficient heat transfer. The coil is protected on all four sides by louvered panels.

## Optional Accessories:

### Low Ambient Cooling

As manufactured, this unit has a cooling capability to 55°F. The addition of an evaporator defrost control with TXV permits low ambient cooling to 30°

### Accessories

Thermostats — Cooling only and heat/cooling (manual and automatic changeover). Sub-base to match thermostat and locking thermostat cover.



# Mechanical Specifications - 4TTA

---

## General

The 4TTA3 is fully charged from the factory for up to 25 feet of piping. This unit is designed to operate at outdoor ambient temperatures as high as 125°F. Cooling capacities are matched with a wide selection of air handlers and furnace coils that are **tested in accordance to AHRI and UL 1995.**

## Casing

Unit casing is constructed of heavy gauge, G90 galvanized steel and painted with a weather-resistant powder paint on all louvers, panels, pre-paint on all other panels. Corrosion and weatherproof CMBP-G30 DuraTuff™ base.

## Refrigerant Controls

Refrigeration system controls include condenser fan and compressor contactor. High and low pressure controls are inherent to the compressor. Liquid line drier is shipped separately with the unit for field installation.

## Compressor

The Scroll compressor features internal over temperature and pressure protection and total dipped hermetic motor and thermostatically controlled sump/ crankcase heater . Other features include: centrifugal oil pump and low vibration and noise.

## Condenser Coil

The outdoor coil provides low airflow resistance and efficient heat transfer. The coil is protected on all four sides by louvered panels.

## Optional Accessories:

### Low Ambient Cooling

As manufactured, this unit has a cooling capability to 55°F. The addition of an evaporator defrost control with TXV permits low ambient cooling to 30° F.

### Accessories

Thermostats — Cooling only and heat/cooling (manual and automatic changeover). Sub-base to match thermostat and locking thermostat cover.





Trane optimizes the performance of homes and buildings around the world. A business of Ingersoll Rand, the leader in creating and sustaining safe, comfortable and energy efficient environments, Trane offers a broad portfolio of advanced controls and HVAC systems, comprehensive building services, and parts. For more information, visit [www.Trane.com](http://www.Trane.com).

Trane has a policy of continuous product and product data improvement and reserves the right to change design and specifications without notice.

© 2013 Trane All rights reserved  
SSA-PRC012A-EN February 2014

We are committed to using  
environmentally conscious print  
practices that reduce waste.

