

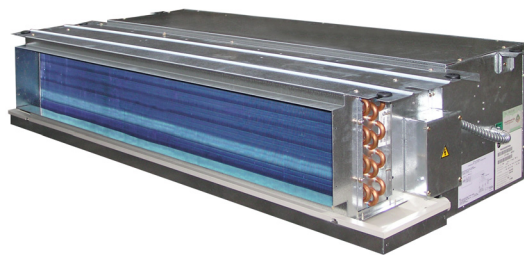

# Product Bulletin

---

**Illusion  
Concealed Type  
Minisplit Air Conditioners  
12,000 - 60,000 Btu/h  
MCD Series 50 / 60 Hz**



#### **Air Handler Models**

MCD009AA	MCD512DB	MCD512D1
MCD012AA	MCD518DB	MCD518D1
MCD018AA	MCD524DB	MCD524D1
MCD024AA	MCD530DB	MCD530D1
MCD030EB	MCD536DB	MCD536D1
MCD036EB	MCD048DB	MCD048D1
MCD042EB	MCD060DB	MCD060D1

#### **Condensing Models**

TTK509LB5	TTK512LB	TTK512L1
TTK512PB5	TTK518PB	TTK518P1
TTK518LB5	TTK524PB	TTK524P1
TTK524LB5	TTK530PB	TTK530P1
TTK530KB5	TTK536KB	TTK536K1
TTK536KB5	TTK536KD	TTK536K4
TTK536KD5	TTK042KD	TTK042K4
TTK042KD5	TTK048KD	TTK048K4
	TTK060KD	TTK060K4

---

**December 2014**

**SSA-PRC006-EN**

## Features and Benefits

---

### MCD Concealed Unit

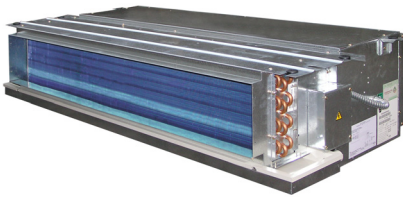

#### Features:

- Compact Design
- Triple Layer Drain Pan\*
- 4 Speed Fan Motor
- Optional Electric Heater
- Optional Return Plenum
- Optional High Efficiency Models

#### Benefits

- Flexibility in installation locations.
- Protect against condensate leaks.
- Flexibility in airflow.
- Whisper quiet operation.
- Ease of installation

\* Note For HK market, Two layer drain pan (galvanized steel sheet with 6 min thickness Armaflex class O insulation) is a standard offering to comply to BS476

### TTK Condensing Unit



#### Features and Benefits

- High efficiency unit with reliable aluminum fin.
- Compact unit size allows for installation in limited or confined spaces.

#### Optional

- Blue fin, Copper fin
- Stainless casing
- 45 degree louver
- Aeris coating
- Super hydrophobic coating

# Contents

---

System Performance Matrix	4
Model Nomenclature	5
General Data	7
Fan Performance Data	19
System Performance Data	26
MCD Wiring Diagram	40
TTK Wiring Diagram	44
MCD Dimensional Data	47
TTK Dimensional Data	51



# System Performance Matrix

## System Performance Matrix: High Efficiency Models

Indoor Unit	Outdoor Unit	Total Capacity MBH	Evaporator CFM	Power Input kW
MCD009AA5	TTK509LB5	10.6	300	0.93
MCD012AA5	TTK512LB5	13.4	400	1.12
MCD018AA5	TTK518LB5	18.1	600	1.58
MCD024AA5	TTK524LB5	25.4	800	2.21
MCD030EB5	TTK530KB5	31.1	1,000	2.72
MCD036EB5	TTK536KB5	36.1	1,200	3.26
MCD036EB5	TTK536KD5	36.2	1,200	3.18
MCD042EB5	TTK042KD5	40.9	1,400	3.45

## System Performance Matrix: 50 Hz

Indoor Unit	Outdoor Unit	Total Capacity MBH	Evaporator CFM	Power Input kW
MCD512DB	TTK512LB	12.9	400	1.57
MCD518DB	TTK518PB	18.4	600	1.96
MCD524DB	TTK524PB	24.6	800	2.64
MCD530DB	TTK530PB	30.6	1,000	3.54
MCD536DB	TTK536KB	36.6	1,200	4.10
MCD536DB	TTK536KD	37.1	1,200	3.96
MCD048DB	TTK042KD	43.1	1,400	5.14
MCD048DB	TTK048KD	50.2	1,600	5.85
MCD060DB	TTK060KD	60.2	2,000	7.32

## System Performance Matrix: 60 Hz

Indoor Unit	Outdoor Unit	Total Capacity MBH	Evaporator CFM	Power Input kW
MCD512D1	TTK512L1	12.8	400	1.54
MCD518D1	TTK518P1	18.7	600	2.14
MCD524D1	TTK524P1	24.2	800	2.63
MCD530D1	TTK530P1	31.8	1,000	3.73
MCD536D1	TTK536K1	36.5	1,200	3.93
MCD536D1	TTK536K4	37.1	1,200	3.90
MCD048D1	TTK042K4	43.1	1,400	5.56
MCD048D1	TTK048K4	49.0	1,600	6.02
MCD060D1	TTK060K4	60.0	2,000	7.29

# Model Nomenclature

---

<u>M</u>	<u>C</u>	<u>D</u>	<u>A</u>	<u>1</u>	<u>2</u>	<u>D</u>	<u>B</u>	<u>P</u>	<u>H</u>	<u>A</u>	<u>A</u>
1	2	3	4	5	6	7	8	9	10	11	12

## Digit 1

M = Mini-Split

## Digit 2

C = Cooling Only

## Digit 3

D = Concealed

## Digit 4 - Refrigerant Connection

0 = Sweat type, R22

5 = Flare type, R22

A = Flare type, R410A (12k-36k)

B = Sweat type, R410A (42k-60k)

C = Flare type, R407C

D = Sweat type, R407C

## Digit 5 , 6 - Nominal Capacity

12 = 12 MBH

18 = 18 MBH

24 = 24 MBH

30 = 30 MBH

36 = 36 MBH

48 = 48 MBH

60 = 60 MBH

## Digit 7

D = High external static pressure

E = Low external static pressure

## Digit 8 - Voltage

B = 220-240/50/1

380-415/50/3

1 = 200-240/60/1

## Digit 9 - Electric Heat and Refrigerant

0 = no heat, no return plenum, standard option

5 = no heat, Egat no.5, standard option

C = 1.0 KW electric heat, no return plenum

D = 1.5 KW electric heat, no return plenum

E = 2.0 KW electric heat, no return plenum

F = 2.5 KW electric heat, no return plenum

G = 3.0 KW electric heat, no return plenum

H = 4.0 KW electric heat, no return plenum

I = 4.5 KW electric heat, no return plenum

## P = no heat, with return plenum

Q = 1.0 KW electric heat, with return plenum

R = 1.5 KW electric heat, with return plenum

S = 2.0 KW electric heat, with return plenum

T = 2.5 KW electric heat, with return plenum

U = 3.0 KW electric heat, with return plenum

V = 4.0 KW electric heat, with return plenum

W = 4.5 KW electric heat, with return plenum

## Digit 10 Option

0 = No option

H = High Efficiency with Filter

## Digit 11

A = Design change

## Digit 12

A = Service part



# Model Nomenclature

<u>T</u>	<u>T</u>	<u>K</u>	<u>5</u>	<u>1</u>	<u>2</u>	<u>P</u>	<u>B</u>	<u>0</u>	<u>0</u>	<u>J</u>	<u>A</u>
1	2	3	4	5	6	7	8	9	10	11	12

## Digit No. 1 = Brand Name

T = Trane

(Others to be determined as needs)

## Digit No. 2 = Functional Type

T = Cooling Only

W = Heat Pump

## Digit No. 3 - Refrigerant Circuit (s) /Compressor(s)

K = Single Refrigerant Circuit/Compressor, Horizontal Discharge

## Digit No. 4 = Refrigerant Connection Type

0 = R22 Sweat (Brazed)

5 = R22 Flared (Tubing)

7 = R22 Quick Connect

C = R407C Flared (Tubing)

D = R407C Sweat (Brazed)

## Digit No. 5 and No. 6 - Nominal Capacity

Btu/h X 1000

(Note: Exact system capacities/performance when matched with selected indoor unit are specified in Product Catalogs.)

## Digit No. 7 - Major Development Sequence primary Design / Form Series

Alphabetic Letter ; "A" Through "Z"

(Assigned by IUS Group Residential Product Management Team)

Note : Letters "T" "U" and "v" are reserved for the development of R410A condensing unit.

## Digit No. 8 - Electric Power Supply Characteristics

A = 220V/1ph/50Hz or 200-220V/1ph/50Hz

B = 240V/1ph/50Hz or 220-240V/1ph/50Hz

1 = 220V/1ph/60Hz or 200-240V/1ph/60Hz

3 = 200-240V/3ph/60Hz

D = 380-415V/3ph/50Hz

4 = 460V/3ph/60Hz

## Digit No. 9 and 10 - Factory Alternate Constructions

(Note: The Alphabetic Letter "O" is not used in digit 9 or 10, only the Number "O" is used.)

0E -- Standard efficiency with expansion device

HE -- High efficiency with expansion device

00 -- Standard efficiency with no expansion device

H0 -- High efficiency with no expansion device

LE -- Low Sound Level with expansion device

L0 -- Low Sound Level with no expansion device

BE -- Black Epoxy coil with expansion devise

B0 -- Black Epoxy coil with no expansion devise

5E -- Efficiency equivalent to EGAT # 5; with expansion device

50 -- Efficiency equivalent to EGAT # 5; with no expansion device

0M -- Standard efficiency with Micro Chanel coil

## Digit No. 11 - Minor Design Sequence/Series - Design Change

Alphabetic Letter, "A" through "Z"

(Coordinated with and approved by IUS Group Residential Unitary Product Management Team)

Note : Design Modifications requiring a change in this digit are those which change either the unit form (e.g., footprint, size, appearance), or fit (e.g., electrical connection, refrigerant connections) or function (e.g., capacity, efficiency, noise level) thereby necessitating a change (s) to the unit marketing specifications /data and/or customer expectations.

## Digit No. 12 - Service Parts

Alphabetic Letter, "A" through "Z"

(Coordinated with and approved by IUS Group Residential Unitary Product Management Team)

Note : Design Modifications requiring a change in this digit are those which (A) change only components and/or factory processes and procedures thereby necessitating a change(s) to the unit service part list & drawing and (B) do not affect or change the unit maketing specifications/data and/or customer expectations

# General Data

General Data MCD 50Hz: High Efficiency

UNIT MODELS		MCD009AA5	MCD012AA5	MCD018AA5	MCD024AA5
<b>POWER CONNECTION</b>	V/ph/Hz	220-240/1/50	220-240/1/50	220-240/1/50	220-240/1/50
<b>MCA</b>	A	0.56	0.56	1.08	2.14
<b>SYSTEM DATA</b>					
Refrigerant Type		R-22	R-22	R-22	R-22
Refrigerant Connection Type		Sweat	Sweat	Sweat	Sweat
Suction Line OD	in (mm)	1/2 (12.70)	5/8 (15.88)	5/8 (15.88)	5/8 (15.88)
Liquid line OD	in (mm)	1/4 (6.35)	3/8 (9.53)	3/8 (9.53)	3/8 (9.53)
<b>COIL</b>					
Face Area	sq ft (m <sup>2</sup> )	1.72 (0.16)	1.72 (0.16)	2.10 (0.20)	2.10 (0.20)
Tube Size OD	in (mm)	3/8 (9.53)	3/8 (9.53)	3/8 (9.53)	3/8 (9.53)
Tube Type		Inner Grooved	Inner Grooved	Inner Grooved	Inner Grooved
Rows		2	3	4	4
Fin Type		Slit/Coated	Slit/Coated	Slit/Coated	Slit/Coated
Fins per inch		18	14	20	20
Refrigerant Flow Control		Capillary Tube	Capillary Tube	Capillary Tube	Capillary Tube
Drain Connection Size	in (mm)	1/2 (12.70)	1/2 (12.70)	1/2 (12.70)	1/2 (12.70)
<b>ELECTRIC HEATER DATA</b>					
Heater Rating	kW	-	-	-	-
Heater RLA	A	-	-	-	-
<b>FAN</b>					
Fan Type		Centrifugal	Centrifugal	Centrifugal	Centrifugal
No. used		2	2	2	2
Diameter	in (mm)	6 (152.4)	6 (152.4)	7 (177.8)	8 (203.2)
Width	in (mm)	8 (203.2)	8 (203.2)	9 (228.6)	9 (228.6)
Drive Type		Direct	Direct	Direct	Direct
<b>MOTOR</b>					
Motor Type		Permanent Split Capacitor			
No. of Motor		1	1	1	1
Motor Power	hp (kW)	1/15 (0.047)	1/15 (0.047)	1/8 (0.089)	1/3 (0.218)
No. of Speed		3	3	4	4
Motor Speed	rpm	1100 / 900 / 800	1100 / 900 / 800	1100 / 1000 / 850 / 700	1230 / 1066 / 870 / 645
RLA/LRA		0.45 / 0.71	0.45 / 0.71	0.86 / 1.26	1.71 / 3.19
<b>FILTER</b>					
Type		No			
No. used		No	No	No	No
No. used per size (WxLxD)	in (mm)	-	-	-	-
<b>DIMENSION (HxWxD)</b>					
Crated (Shipping)	in (mm)	12.8 x 39.4 x 19.5 (324 x 1,000 x 495)	12.8 x 39.4 x 19.5 (324 x 1,000 x 495)	13.2 x 45.6 x 22.1 (335 x 1,158 x 562)	14.2 x 51.6 x 22.1 (360 x 1,311 x 562)
Uncrated (Net)	in (mm)	10.2 x 37.2 x 17.9 (258 x 946 x 456)	10.2 x 37.2 x 17.9 (258 x 946 x 456)	10.6 x 43.2 x 19.0 (270 x 1,098 x 482)	12.8 x 43.2 x 20.5 (325 x 1098 x 520)
<b>WEIGHT</b>					
Crated (Shipping)					
Without electric heater	lb (kg)	53.0 (24.0)	54.0 (24.5)	62.2 (28.2)	64.4 (29.2)
With electric heater	lb (kg)	-	-	-	-
Uncrated (Net)					
Without electric heater	lb (kg)	50.0 (22.7)	51.0 (23.2)	59.2 (26.9)	61.4 (27.9)
With electric heater	lb (kg)	-	-	-	-

<sup>1</sup> MCA - Minimum Circuit Ampacity ; calculated as follow : 125% of fan motor R.L Amps.



# General Data

## General Data MCD 50Hz: High Efficiency Models

MODELS		MCD030EB5	MCD036EB5	MCD042EB5
<b>POWER CONNECTION</b>	V/ph/Hz	220-240/1/50	220-240/1/50	220-240/1/50
<b>MCA<sup>1</sup></b>	A	2.14	1.75	2.86
<b>SYSTEM DATA</b>				
Refrigerant Type		R-22	R-22	R-22
Refrigerant Connection Type		Sweat	Sweat	Sweat
Suction Line OD	in (mm)	3/4 (19.05)	3/4 (19.05)	7/8 (22.23)
Liquid line OD	in (mm)	3/8 (9.53)	3/8 (9.53)	3/8 (9.53)
<b>COIL</b>				
Face Area	sq ft (m <sup>2</sup> )	2.33 (0.22)	3.50 (0.33)	3.50 (0.33)
Tube Size OD	in (mm)	3/8 (9.53)	3/8 (9.53)	3/8 (9.53)
Tube Type		Inner Grooved	Plain	Plain
Rows		4	4	4
Fin Type		Slit/Coated	Slit/Coated	Slit/Coated
Fins per inch		20	16	16
Refrigerant Flow Control		Capillary Tube	Capillary Tube	Capillary Tube
Drain Connection Size	in (mm)	1/2 (12.70)	1/2 (12.70)	1/2 (12.70)
<b>ELECTRIC HEATER DATA</b>				
Heater Rating	kW	-	-	-
Heater RLA		-	-	-
<b>FAN</b>				
Fan Type		Centrifugal	Centrifugal	Centrifugal
No. used		2	2	2
Diameter	in (mm)	8 (203.2)	8 (203.2)	8 (203.2)
Width	in (mm)	9 (228.6)	9 (228.6)	9 (228.6)
Drive Type		Direct	Direct	Direct
<b>MOTOR</b>				
Motor Type		Permanent Split Capacitor		
No. of Motor		1	1	1
Motor Power	hp (kW)	1/3 (0.218)	1/4 (0.168)	1/3 (0.210)
No. of Speed		4	3	4
Motor Speed	rpm	1230 / 1066 / 870 / 645	900 / 783 / 632	1000 / 900 / 800 / 700
V/ph/Hz		220/1/50	220/1/50	220/1/50
RLA/LRA		1.71 / 3.19	1.39 / 3.01	2.29 / 3.15
<b>FILTER</b>				
Type		Aluminum Filter		
No. used		2	2	2
No. used per size (WxLxD)	in (mm)	12.6 x 21.8 x 1.0 (320 x 555 x 25)	13.7 x 18.8 x 1.0 (350 x 478 x 25)	13.7 x 18.8 x 1.0 (350 x 478 x 25)
<b>DIMENSION (HxWxD)</b>				
Crated (Shipping)	in (mm)	18.9 x 51.9 x 30.6 (479 x 1,318 x 778)	18.9 x 46.0 x 30.6 (479 x 1,168 x 778)	18.9 x 46.0 x 30.6 (479 x 1,168 x 778)
Uncrated (Net)	in (mm)	13.7 x 49.3 x 26.5 (348 x 1,251 x 672)	16.1 x 43.2 x 29.9 (408 x 1,098 x 759)	16.1 x 43.2 x 29.9 (408 x 1,098 x 759)
<b>WEIGHT</b>				
Crated (Shipping)				
Without electric heater	lb (kg)	100.5 (45.6)	112.9 (51.3)	120.1 (54.5)
With electric heater	lb (kg)	-	-	-
Uncrated (Net)				
Without electric heater	lb (kg)	90.6 (41.1)	103.0 (46.8)	110.2 (50.0)
With electric heater	lb (kg)	-	-	-

<sup>1</sup> MCA - Minimum Circuit Ampacity ; calculated as follow : 125% of fan motor R.L Amps.



# General Data

## General Data MCD 50Hz

UNIT MODEL		MCD512DB0	MCD518DB0	MCD524DB0	MCD530DB0	MCD536DB0
		MCD512DBE <sup>1</sup>	MCD518DBF <sup>1</sup>	MCD524DBG <sup>1</sup>	MCD530DBH <sup>1</sup>	MCD536DBI <sup>1</sup>
		MCD512DBP <sup>2</sup>	MCD518DBP <sup>2</sup>	MCD524DBP <sup>2</sup>	MCD530DBP <sup>2</sup>	MCD536DBP <sup>2</sup>
		MCD512DBS <sup>3</sup>	MCD518DBT <sup>3</sup>	MCD524DBU <sup>3</sup>	MCD530DBV <sup>3</sup>	MCD536DBW <sup>3</sup>
POWER CONNECTION	V/ph/Hz	220-240/1/50	220-240/1/50	220-240/1/50	220-240/1/50	220-240/1/50
MCA <sup>4</sup>	A	12.0	15.3	18.4	25.1	27.9
SYSTEM DATA						
Refrigerant Type		R-22	R-22	R-22	R-22	R-22
Refrigerant Connection Type		Flare	Flare	Flare	Flare	Flare
Suction Line OD		in (mm)	1/2 (12.70)	5/8 (15.88)	5/8 (15.88)	3/4 (19.05)
Liquid line OD		in (mm)	1/4 (6.35)	3/8 (9.53)	3/8 (9.53)	3/8 (9.53)
COIL						
Face Area		sq ft (m <sup>2</sup> )	1.67 (0.16)	1.67 (0.16)	1.67 (0.16)	2.00 (0.19)
Tube Size OD		in (mm)	5/16 (7.93)	5/16 (7.93)	5/16 (7.93)	5/16 (7.93)
Tube Type			Plain	Inn. Grv.	Inn. Grv.	Inn. Grv.
Rows			2	2	3	3
Fin Type			Precoated Slit	Precoated Slit	Precoated Slit	Precoated Slit
Fins per inch			19	20	15	14
Refrigerant Flow Control			Capillary Tube	Capillary Tube	Capillary Tube	Capillary Tube
Drain Connection Size		in (mm)	1/2 (12.70)	1/2 (12.70)	1/2 (12.70)	1/2 (12.70)
ELECTRIC HEATER DATA <sup>1,3</sup>						
Heater Rating		kW	2	2.5	3	4 (2 elements)
Heater RLA			9.1	11.4	13.6	18.2
FAN						
Fan Type			Centrifugal	Centrifugal	Centrifugal	Centrifugal
No. used			2	2	2	2
Diameter		in (mm)	6 (144.0)	6 (144.0)	7 (164.0)	7 (164.0)
Width		in (mm)	7 (188.0)	7 (188.0)	8 (201.0)	8 (201.0)
Drive Type			Direct	Direct	Direct	Direct
MOTOR						
Motor Type			Permanent Split Capacitor			
No. of Motor			1	1	1	1
Motor Power		hp (kW)	1/20 (0.041)	1/8 (0.087)	1/4 (0.193)	1/3 (0.278)
No. of Speed			4	4	4	4
Motor Speed		rpm	1200 / 1100 / 1000 / 900	1400 / 1300 / 1200 / 1100	1400 / 1200 / 1100 / 1000	1400 / 1350 / 1250 / 1100
V/ph/Hz			220/1/50	220/1/50	220/1/50	220/1/50
RLA/LRA			0.48 / 0.80	0.82 / 1.86	1.09 / 3.15	1.90 / 5.28
FILTER <sup>2,3</sup>						
Type			Aluminum Filter			
No. used			1	1	1	1
Size (WxLxD)		in <sup>3</sup>	10.6 x 30.3 x 1.0	10.6 x 30.3 x 1.0	10.6 x 30.3 x 1.0	10.6 x 36.3 x 1.0
		(mm) <sup>3</sup>	(270 x 770 x 25)	(270 x 770 x 25)	(270 x 770 x 25)	(270 x 922 x 25)
DIMENSION (HxWxD)						
Crated (Shipping)		in <sup>3</sup>	13.2 x 39.8 x 22.2	13.2 x 39.8 x 22.2	13.2 x 39.8 x 22.2	13.2 x 45.6 x 22.2
		(mm) <sup>3</sup>	(335 x 1,010 x 565)	(335 x 1,010 x 565)	(335 x 1,010 x 565)	(335 x 1,158 x 565)
Crated (Shipping) <sup>2,3</sup>		in <sup>3</sup>	12.2 x 37.4 x 25.2	12.2 x 37.4 x 25.2	12.2 x 37.4 x 25.2	12.2 x 43.7 x 25.2
		(mm) <sup>3</sup>	(311 x 949 x 641)	(311 x 949 x 641)	(311 x 949 x 641)	(311 x 1,111 x 641)
Uncrated (Net)		in <sup>3</sup>	10.2 x 37.2 x 19.4	10.2 x 37.2 x 19.4	10.2 x 37.2 x 20.0	10.2 x 43.2 x 20.9
		(mm) <sup>3</sup>	(258 x 946 x 494)	(258 x 946 x 494)	(258 x 946 x 509)	(258 x 1,098 x 531)
Uncrated (Net) <sup>2,3</sup>		in <sup>3</sup>	11.8 x 37.2 x 24.6	11.8 x 37.2 x 24.6	11.8 x 37.2 x 24.6	11.8 x 43.2 x 24.6
		(mm) <sup>3</sup>	(300 x 946 x 625)	(300 x 946 x 625)	(300 x 946 x 625)	(300 x 1,098 x 625)
WEIGHT						
Crated (Shipping)		lb (kg)	49.7 (22.6)	53.7 (24.5)	58.5 (26.2)	67.0 (29.8)
Crated (Shipping) <sup>1</sup>		lb (kg)	52.7 (24.0)	56.7 (25.8)	62.0 (27.8)	72.0 (32.1)
Crated (Shipping) <sup>2</sup>		lb (kg)	68.7 (31.3)	72.7 (33.1)	78.5 (35.0)	89.0 (39.8)
Crated (Shipping) <sup>3</sup>		lb (kg)	71.7 (32.6)	75.7 (34.5)	80.5 (36.0)	94.0 (42.1)
Uncrated (Net)		lb (kg)	44.7 (20.4)	48.7 (22.2)	54.0 (24.0)	60.0 (26.7)
Uncrated (Net) <sup>1</sup>		lb (kg)	47.7 (21.7)	51.7 (23.6)	57.0 (25.3)	65.0 (29.0)
Uncrated (Net) <sup>2</sup>		lb (kg)	63.7 (29.0)	67.7 (30.8)	73.0 (32.5)	83.0 (37.0)
Uncrated (Net) <sup>3</sup>		lb (kg)	66.7 (30.4)	70.7 (32.2)	76.0 (34.0)	87.0 (39.0)

<sup>1</sup> Model with electric heater has alphabetic letter E F G H or I in the ninth digit

<sup>2</sup> Model with plenum has alphabetic letter P in the ninth digit

<sup>3</sup> Model with electric heater and plenum has alphabetic letter S T U V or W in the ninth digit

<sup>4</sup> MCA - Minimum Circuit Ampacity ; calculated as follow : 125% of motor R.L.Amps plus heater R.L.Amps .



# General Data

## General Data MCD 50Hz

UNIT MODELS		MCD048DBP MCD048DBY <sup>1</sup>	MCD060DBP MCD060DBZ <sup>1</sup>
<b>POWER CONNECTION</b>	V/ph/Hz	220-240/1/50	220-240/1/50
<b>MCA<sup>2</sup></b>	A	38.0	44.7
<b>SYSTEM DATA</b>			
Refrigerant Type		R-22	R-22
Refrigerant Connection Type		Brazed	Brazed
Suction Line OD	in (mm)	1 1/8 (28.58)	1 1/8 (28.58)
Liquid line OD	in (mm)	3/8 (9.53)	3/8 (9.53)
<b>COIL</b>			
Face Area	sq ft (m2)	3.50 (0.33)	4.08 (0.38)
Tube Size OD	in (mm)	5/16 (7.93)	5/16 (7.93)
Tube Type		Plain	Inn. Grv.
Rows		3	3
Fin Type		Precoated Slit	Precoated Slit
Fins per inch		14	15
Refrigerant Flow Control		Capillary Tube	Capillary Tube
Drain Connection Size	in (mm)	1/2 (12.70)	1/2 (12.70)
<b>ELECTRIC HEATER DATA <sup>1</sup></b>			
Heater Rating	kW	6 (2 elements)	7 (2 elements)
Heater RLA		27.2	31.8
<b>FAN</b>			
Fan Type		Centrifugal	Centrifugal
No. used		2	2
Diameter	in (mm)	8 (203.2)	8 (203.2)
Width	in (mm)	9 (228.6)	10(254.0)
Drive Type		Direct	Direct
<b>MOTOR</b>			
Motor Type		Permanent split capacitor	
No. of Motor		1	1
Motor Power	hp (kW)	1/2 (0.394)	3/4 (0.453)
No. of Speed		4	4
Motor Speed	rpm	1200 / 1100 / 1000 / 850	1250 / 1100 / 970 / 850
V/ph/Hz		220-240/1/50	220-240/1/50
RLA/LRA		3.11 / 5.08	3.94 / 6.98
<b>FILTER</b>			
Type		Aluminum Filter	
No. used		1	1
Size (WxLxD)	in3 (mm)3	13.7 x 35.4 x 1.0 (350 x 901 x 25)	13.7 x 41.5 x 1.0 (350 x 1,054 x 25)
<b>DIMENSION (HxWxD)</b>			
Crated (Shipping)	in3 (mm)3	19.3 x 46.0 x 30.8 (490 x 1,168 x 782)	19.3 x 51.9 x 30.8 (490 x 1,317 x 782)
Uncrated (Net)	in3 (mm)3	16.0 x 43.2 x 29.8 (408 x 1,098 x 759)	16.0 x 49.2 x 29.8 (408 x 1,251 x 759)
<b>WEIGHT</b>			
Crated (Shipping)	lb (kg)	116.6 (53.0)	132.0 (60.0)
Crated (Shipping) <sup>1</sup>	lb (kg)	125.4 (57.0)	143.0 (65.0)
Uncrated (Net)	lb (kg)	106.7 (48.5)	121.0 (55.0)
Uncrated (Net) <sup>1</sup>	lb (kg)	115.5 (52.5)	132.0 (60.0)

<sup>1</sup> Model with electric heater has alphabetic letter Y or Z in the ninth digit.

<sup>2</sup> MCA - Minimum Circuit Ampacity ; calculated as follow : 125 % of motor R.L.Amps plus heater R.L.Amps.

# General Data

## General Data MCD 60Hz

UNIT MODEL		MCD512D10	MCD518D10	MCD524D10	MCD530D10	MCD536D10
		MCD512D1E <sup>1</sup>	MCD518D1F <sup>1</sup>	MCD524D1G <sup>1</sup>	MCD530D1H <sup>1</sup>	MCD536D1I <sup>1</sup>
		MCD512D1P <sup>2</sup>	MCD518D1P <sup>2</sup>	MCD524D1P <sup>2</sup>	MCD530D1P <sup>2</sup>	MCD536D1P <sup>2</sup>
		MCD512D1S <sup>3</sup>	MCD518D1T <sup>3</sup>	MCD524D1U <sup>3</sup>	MCD530D1V <sup>3</sup>	MCD536D1W <sup>3</sup>
<b>POWER CONNECTION</b>		V/ph/Hz	200-240/1/60	200-240/1/60	200-240/1/60	200-240/1/60
<b>MCA<sup>4</sup></b>	A	12.1	15.3	18.8	25.1	28.1
<b>SYSTEM DATA</b>						
Refrigerant Type		R-22	R-22	R-22	R-22	R-22
Refrigerant Connection Type		Flare	Flare	Flare	Flare	Flare
Suction Line OD	in (mm)	1/2 (12.70)	1/2 (12.70)	5/8 (15.88)	5/8 (15.88)	3/4 (19.05)
Liquid line OD	in (mm)	1/4 (6.35)	1/4 (6.35)	3/8 (9.53)	3/8 (9.53)	3/8 (9.53)
<b>COIL</b>						
Face Area	sq ft (m <sup>2</sup> )	1.67 (0.16)	1.67 (0.16)	1.67 (0.16)	2.00 (0.19)	2.33 (0.22)
Tube Size OD	in (mm)	5/16 (7.93)	5/16 (7.93)	5/16 (7.93)	5/16 (7.93)	5/16 (7.93)
Tube Type		Plain	Inn. Grv.	Inn. Grv.	Inn. Grv.	Inn. Grv.
Rows		2	2	3	3	3
Fin Type		Precoated Slit	Precoated Slit	Precoated Slit	Precoated Slit	Precoated Slit
Fins per inch		19	20	15	15	14
Refrigerant Flow Control		Capillary Tube	Capillary Tube	Capillary Tube	Capillary Tube	Capillary Tube
Drain Connection Size	in (mm)	1/2 (12.70)	1/2 (12.70)	1/2 (12.70)	1/2 (12.70)	1/2 (12.70)
<b>ELECTRIC HEATER DATA <sup>1,3</sup></b>						
Heater Rating	kW	2	2.5	3	4 (2 elements)	4.5 (2 elements)
Heater RLA		9.1	11.4	13.6	18.2	20.5
<b>FAN</b>						
Fan Type		Centrifugal	Centrifugal	Centrifugal	Centrifugal	Centrifugal
No. used		2	2	2	2	2
Diameter	in (mm)	6 (144.0)	6 (144.0)	7 (164.0)	7 (164.0)	7 (164.0)
Width	in (mm)	7 (188.0)	7 (188.0)	8 (201.0)	8 (201.0)	8 (201.0)
Drive Type		Direct	Direct	Direct	Direct	Direct
<b>MOTOR</b>						
Motor Type		Permanent Split Capacitor				
No. of Motor		1	1	1	1	1
Motor Power	hp (kW)	1/20 (0.043)	1/8 (0.093)	1/4 (0.178)	1/3 (0.243)	1/2 (0.258)
No. of Speed		4	4	4	4	4
Motor Speed	rpm	1200 / 1100 / 1000 / 900	1450 / 1300 / 1200 / 1100	1450 / 1200 / 1100 / 1000	1450 / 1350 / 1250 / 1100	1450 / 1350 / 1250 / 1150
V/ph/Hz		220/1/60	220/1/60	220/1/60	220/1/60	220/1/60
RLA/LRA		0.58 / 0.70	0.81 / 1.20	1.46 / 2.04	1.87 / 2.59	2.0 / 3.65
<b>FILTER <sup>2,3</sup></b>						
Type		Aluminum Filter				
No. used		1	1	1	1	1
Size (WxLxD)	in <sup>3</sup> (mm) <sup>3</sup>	10.6 x 30.3 x 1.0 (270 x 770 x 25)	10.6 x 30.3 x 1.0 (270 x 770 x 25)	10.6 x 30.3 x 1.0 (270 x 770 x 25)	10.6 x 36.3 x 1.0 (270 x 922 x 25)	10.6 x 42.4 x 1.0 (270 x 1,077 x 25)
<b>DIMENSION (HxWxD)</b>						
Crated (Shipping)	in <sup>3</sup> (mm) <sup>3</sup>	13.2 x 39.8 x 22.2 (335 x 1,010 x 565)	13.2 x 39.8 x 22.2 (335 x 1,010 x 565)	13.2 x 39.8 x 22.2 (335 x 1,010 x 565)	13.2 x 45.6 x 22.2 (335 x 1,158 x 565)	13.2 x 51.6 x 22.2 (335 x 1,311 x 565)
Crated (Shipping) <sup>2,3</sup>	in <sup>3</sup> (mm) <sup>3</sup>	12.2 x 37.4 x 25.2 (311 x 949 x 641)	12.2 x 37.4 x 25.2 (311 x 949 x 641)	12.2 x 37.4 x 25.2 (311 x 949 x 641)	12.2 x 43.7 x 25.2 (311 x 1,111 x 641)	12.2 x 49.8 x 25.2 (311 x 1,264 x 641)
Uncrated (Net)	in <sup>3</sup> (mm) <sup>3</sup>	10.2 x 37.2 x 19.4 (258 x 946 x 494)	10.2 x 37.2 x 19.4 (258 x 946 x 494)	10.2 x 37.2 x 20.0 (258 x 946 x 509)	10.2 x 43.2 x 20.0 (258 x 1,098 x 509)	10.2 x 49.3 x 20.0 (258 x 1,251 x 509)
Uncrated (Net) <sup>2,3</sup>	in <sup>3</sup> (mm) <sup>3</sup>	11.8 x 37.2 x 24.6 (300 x 946 x 625)	11.8 x 37.2 x 24.6 (300 x 946 x 625)	11.8 x 37.2 x 24.6 (300 x 946 x 625)	11.8 x 43.2 x 24.6 (300 x 1,098 x 625)	11.8 x 49.3 x 24.6 (300 x 1,251 x 625)
<b>WEIGHT</b>						
Crated (Shipping)	lb (kg)	49.7 (22.6)	53.7 (24.5)	58.5 (26.2)	67.0 (29.8)	74.0 (33.0)
Crated (Shipping) <sup>1</sup>	lb (kg)	52.7 (24.0)	56.7 (25.8)	62.0 (27.8)	72.0 (32.1)	79.0 (35.3)
Crated (Shipping) <sup>2</sup>	lb (kg)	68.7 (31.3)	72.7 (33.1)	78.5 (35.0)	89.0 (39.8)	99.5 (44.4)
Crated (Shipping) <sup>3</sup>	lb (kg)	71.7 (32.6)	75.7 (34.5)	80.5 (36.0)	94.0 (42.1)	104.5 (46.7)
Uncrated (Net)	lb (kg)	44.7 (20.4)	48.7 (22.2)	54.0 (24.0)	60.0 (26.7)	66.0 (29.4)
Uncrated (Net) <sup>1</sup>	lb (kg)	47.7 (21.7)	51.7 (23.6)	57.0 (25.3)	65.0 (29.0)	71.0 (31.7)
Uncrated (Net) <sup>2</sup>	lb (kg)	63.7 (29.0)	67.7 (30.8)	73.0 (32.5)	83.0 (37.0)	91.0 (40.8)
Uncrated (Net) <sup>3</sup>	lb (kg)	66.7 (30.4)	70.7 (32.2)	76.0 (34.0)	87.0 (39.0)	96.0 (43.0)

<sup>1</sup> Model with electric heater has alphabetic letter E F G H or I in the ninth digit

<sup>2</sup> Model with plenum has alphabetic letter P in the ninth digit

<sup>3</sup> Model with electric heater and plenum has alphabetic letter S T U V or W in the ninth digit

<sup>4</sup> MCA - Minimum Circuit Ampacity ; calculated as follow : 125 % of motor R.L.Amps plus heater R.L.Amps.

# General Data

## General Data MCD 60Hz

UNIT MODELS		MCD048D1P	MCD060D1P
		MCD048D1Y <sup>1</sup>	MCD060D1Z <sup>1</sup>
POWER CONNECTION	V/ph/Hz	220-240/1/60	220-240/1/60
MCA <sup>2</sup>	A	37.85	44.6
<b>SYSTEM DATA</b>			
Refrigerant Type		R-22	R-22
Refrigerant Connection Type		Brazed	Brazed
Suction Line OD	in (mm)	1 1/8 (28.58)	1 1/8 (28.58)
Liquid line OD	in (mm)	3/8 (9.53)	3/8 (9.53)
<b>COIL</b>			
Face Area	sq ft (m <sup>2</sup> )	3.50 (0.33)	4.08 (0.38)
Tube Size OD	in (mm)	5/16 (7.93)	5/16 (7.93)
Tube Type		Plain	Inn. Grv.
Rows		3	3
Fin Type		Precoated Slit	Precoated Slit
Fins per inch		14	15
Refrigerant Flow Control		Capillary Tube	Capillary Tube
Drain Connection Size	in (mm)	1/2 (12.70)	1/2 (12.70)
<b>ELECTRIC HEATER DATA <sup>1</sup></b>			
Heater Rating	kW	6 (2 elements)	7 (2 elements)
Heater RLA		27.3	31.8
<b>FAN</b>			
Fan Type		Centrifugal	Centrifugal
No. used		2	2
Diameter	in (mm)	8 (203.2)	9 (228.6)
Width	in (mm)	9 (228.6)	7 (177.8)
Drive Type		Direct	Direct
<b>MOTOR</b>			
Motor Type		Permanent split capacitor	
No. of Motor		1	1
Motor Power	hp (kW)	1/2 (0.333)	3/4 (0.487)
No. of Speed		4	4
Motor Speed	rpm	1120 / 1070 / 980 / 865	950 / 850 / 750 / 650
V/ph/Hz		220-240/1/60	220-240/1/60
RLA/LRA		2.98 / 7.22	3.88 / 5.43
<b>FILTER</b>			
Type		Aluminum Filter	
No. used		1	1
Size (WxLxD)	in <sup>3</sup> (mm) <sup>3</sup>	13.7 x 35.4 x 1.0 (350 x 901 x 25)	14.9 x 41.5 x 1.0 (377 x 1,054 x 25)
<b>DIMENSION (HxWxD)</b>			
Crated (Shipping)	in <sup>3</sup> (mm) <sup>3</sup>	19.3 x 46.0 x 30.8 (490 x 1,168 x 782)	19.3 x 51.9 x 30.8 (490 x 1,317 x 782)
Uncrated (Net)	in <sup>3</sup> (mm) <sup>3</sup>	16.0 x 43.2 x 29.8 (408 x 1,098 x 759)	16.0 x 49.2 x 29.8 (408 x 1,251 x 759)
<b>WEIGHT</b>			
Crated (Shipping)	lb (kg)	116.6 (53.0)	132.0 (60.0)
Crated (Shipping) <sup>1</sup>	lb (kg)	125.4 (57.0)	143.0 (65.0)
Uncrated (Net)	lb (kg)	106.7 (48.5)	121.0 (55.0)
Uncrated (Net) <sup>1</sup>	lb (kg)	115.5 (52.5)	132.0 (60.0)

<sup>1</sup> Model with electric heater has alphabetic letter Y or Z in the ninth digit.

<sup>2</sup> MCA - Minimum Circuit Ampacity ; calculated as follow : 125 % of motor R.L.Amps plus heater R.L.Amps.

# General Data

## General Data TTK 50 Hz: High Efficiency Models

UNIT MODELS		TTK509LB5	TTK512LB5	TTK518LB5	TTK524LB5
<b>POWER CONNECTION</b>	V/ph/Hz	220-240/1/50	220-240/1/50	220-240/1/50	220-240/1/50
<b>MCA<sup>1,3</sup></b>	A	5.7	6.7	9.7	14.3
<b>SYSTEM DATA</b>					
Refrigerant Type		R-22	R-22	R-22	R-22
No. Refrigerant Circuits		1	1	1	1
Refrigerant Connection Type		Flare	Flare	Flare	Flare
Refrigerant Charge	lb (kg)	2.64 (1.20)	4.19 (1.90)	4.87 (2.21)	6.06 (2.75)
Suction Line OD	in (mm)	1/2 (12.7)	5/8 (15.88)	5/8 (15.88)	5/8 (15.88)
Liquid line OD	in (mm)	1/4 (6.35)	3/8 (9.53)	3/8 (9.53)	3/8 (9.53)
<b>COMPRESSOR</b>					
Compressor Type		Rotary	Rotary	Rotary	Scroll
No. Used		1	1	1	1
V/ph/Hz		220/1/50	220/1/50	220/1/50	220/1/50
RLA/LRA		4.16 / 21.0	5.0 / 29.0	7.1 / 36.0	10.7 / 51.0
<b>COIL</b>					
Face Area	sq ft (m <sup>2</sup> )	4.74 (0.44)	4.74 (0.44)	5.60 (0.52)	7.29 (0.68)
Tube Size OD	in (mm)	3/8 (9.53)	3/8 (9.53)	3/8 (9.53)	3/8 (9.53)
Tube Type		Inn. Grv.	Smooth	Inn. Grv.	Inn. Grv.
Rows		2	2	2	2
Fin Type		Uncoated Corrugated			
Fins per inch		14	14	18	20
Refrigerant Flow Control		-	-	-	-
<b>FAN</b>					
Fan Type		Propeller	Propeller	Propeller	Propeller
No. used		1	1	1	1
Diameter	in (mm)	18 (457.2)	18 (457.2)	18 (457.2)	20 (508.0)
No. of Blade		4	4	4	4
Pitch Angle	degree	25	25	30	30
Drive Type		Direct	Direct	Direct	Direct
Nominal Airflow <sup>2</sup>	cfm (cmh)	1490 (2530)	1360 (2315)	1600 (2717)	2130 (3625)
<b>MOTOR</b>					
Motor Type		Permanent Split Capacitor			
No. of Motor		1	1	1	1
Motor hp	hp (kW)	1/15 (0.052)	1/15 (0.052)	1/8 (0.098)	1/6 (0.102)
No. of Speed		1	1	1	1
Motor Speed	rpm	900	900	900	900
V/ph/Hz		220/1/50	220/1/50	220/1/50	220/1/50
RLA/LRA		0.46 / 0.93	0.46 / 0.93	0.8 / 1.79	0.9 / 1.79
<b>DIMENSION (HxWxD) <sup>4</sup></b>					
Crated (Shipping)	in	25.7 x 36.9 x 15.8	25.7 x 36.9 x 15.8	29.8 x 36.9 x 15.8	33.8 x 45.0 x 16.9
	(mm)	(653 x 938 x 401)	(653 x 938 x 401)	(755 x 938 x 401)	(858 x 1,144 x 430)
Uncrated (Net)	i	23.0 x 32.7 x 13.0	23.0 x 32.7 x 13.0	27.3 x 32.7 x 13.	31.3 x 40.0 x 14.2
	(mm)	(585 x 830 x 330)	(585 x 830 x 330)	(692 x 830 x 330)	(795 x 1,018 x 360)
<b>WEIGHT</b>					
Crated (Shipping)	lb (kg)	87.5 (39.8)	104.7 (47.5)	130.1 (59.0)	165.5 (75.0)
Uncrated (Net)	lb (kg)	79.6 (36.2)	93.7 (42.5)	119.1 (54.0)	154.4 (70.0)

<sup>1</sup> MCA - Minimum Circuit Ampacity ; calculated as follow : 125% of compressor R.L.Amps plus the condenser fan motor R.L.Amps.

<sup>2</sup> CFM is rated with standard air-dry coil.

<sup>3</sup> At ARI system rating conditions 80°F-DB/67°F-WB indoor & 95°F-DB outdoor

<sup>4</sup> For uncrated, outdoor unit's width and depth do not include the size of the mounting feet



# General Data

## General Data TTK 50 Hz: High Efficiency Models

UNIT MODELS		TTK530KB5	TTK536KB5	TTK536KD5	TTK042KD5
<b>POWER CONNECTION</b>					
V/ph/Hz		220-240/1/50	220-240/1/50	380-415/3/50	380-415/3/50
MCA <sup>1, 3</sup>	A	14.7	22.3	8.9	8.3
<b>SYSTEM DATA</b>					
Refrigerant Type		R-22	R-22	R-22	R-22
No. Refrigerant Circuits		1	1	1	1
Refrigerant Connection Type		Flare	Flare	Flare	Sweat
Refrigerant Charge	lb (kg)	7.27 (3.3)	9.70 (4.40)	9.61 (3.0)	8.18 (4.2)
Suction Line OD	in (mm)	3/4 (19.05)	3/4 (19.05)	3/4 (19.05)	7/8 (22.23)
Liquid line OD	in (mm)	3/8 (9.53)	3/8 (9.53)	3/8 (9.53)	3/8 (9.53)
<b>COMPRESSOR</b>					
Compressor Type		Rotary	Scroll	Scroll	Scroll
No. Used		1	1	1	1
V/ph/Hz		220/1/50	220/1/50	380/3/50	380/3/50
RLA/LRA		11.0/59.0	17.1/100	6.4/46.0	5.5/41.0
<b>COIL</b>					
Face Area	sq ft (m <sup>2</sup> )	7.29 (0.68)	7.08 (0.66)	7.08 (0.66)	7.08 (0.66)
Tube Size OD	in (mm)	3/8 (9.53)	3/8 (9.53)	3/8 (9.53)	3/8 (9.53)
Tube Type		Inn. Grv.	Inn. Grv.	Inn. Grv.	Inn. Grv.
Rows		2	3	3	3
Fin Type		Uncoated Corrugated			
Fins per inch		20	16	16	20
Refrigerant Flow Control		-	-	-	-
<b>FAN</b>					
Fan Type		Propeller	Propeller	Propeller	Propeller
No. used		1	1	1	1
Diameter	in (mm)	20 (508.0)	20 (508.0)	20 (508.0)	20 (508.0)
No. of Blade		4	3	3	3
Pitch Angle	degree	30	32	32	32
Drive Type		Direct	Direct	Direct	Direct
Nominal Airflow <sup>2</sup>	cfm (cmh)	2130 (3625)	1903 (3233)	1903 (3233)	1903 (3233)
<b>MOTOR</b>					
Motor Type		Permanent Split Capacitor			
No. of Motor		1	1	1	1
Motor hp	hp (kW)	1/6 (0.102)	1/6 (0.102)	1/6 (0.102)	1/4 (0.165)
No. of Speed		1	1	1	1
Motor Speed	rpm	900	900	900	900
V/ph/Hz		220/1/50	220/1/50	220/1/50	230/1/50
RLA/LRA		0.9 / 1.79	0.9 / 1.79	0.9 / 1.79	1.45 / 2.68
<b>4</b>					
Crated (Shipping)	in (mm)	33.8 x 45.0 x 16.9 (858 x 1,144 x 430)			
Uncrated (Net)	in (mm)	31.3 x 40.0 x 14.2 (795 x 1,018 x 360)			
<b>WEIGHT</b>					
Crated (Shipping)	lb (kg)	165.5 (75.0)	165.5 (76.0)	167.1 (76.8)	209.0 (94.8)
Uncrated (Net)	lb (kg)	154.4 (70.0)	154.4 (71.0)	151.7 (69.8)	187.0 (84.9)

<sup>1</sup> MCA - Minimum Circuit Ampacity ; calculated as follow : 125 % of compressor R.L.Amps plus the condenser fan motor R.L.Amps.

<sup>2</sup> CFM is rated with standard air-dry coil.

<sup>3</sup> At ARI system rating conditions 80°F-DB/67°F-WB indoor & 95°F-DB outdoors

<sup>4</sup> For uncrated, outdoor unit's width and depth do not include the size of the mounting feet

# General Data

## General Data TTK 50 Hz

UNIT MODELS		TTK512LB	TTK518PB	TTK524PB	TTK530PB
<b>POWER CONNECTION</b>	V/ph/Hz	220-240/1/50	220-240/1/50	220-240/1/50	220-240/1/50
<b>MCA<sup>1,3</sup></b>	A	7.1	11.0	14.6	18.6
<b>SYSTEM DATA</b>					
Refrigerant Type		R-22	R-22	R-22	R-22
No. Refrigerant Circuits		1	1	1	1
Refrigerant Connection Type		Flare	Flare	Flare	Flare
Refrigerant Charge	lb (kg)	2.65 (1.20)	3.53 (1.60)	4.41 (2.00)	5.51 (2.50)
Suction Line OD	in (mm)	1/2(12.7)	1/2 (12.7)	5/8 (15.88)	5/8 (15.88)
Liquid line OD	in (mm)	1/4(6.35)	1/4 (6.53)	3/8 (9.53)	3/8 (9.53)
<b>COMPRESSOR</b>					
Compressor Type		Rotary	Rotary	Rotary	Rotary
No. Used		1	1	1	1
V/ph/Hz		220/1/50	220/1/50	220/1/50	220/1/50
RLA/LRA		5.3/29	8.43 / 43.0	11.0 / 59.0	14.2 / 85.0
<b>COIL</b>					
Face Area	sq ft (m <sup>2</sup> )	0.74 (0.44)	5.60 (0.52)	5.60 (0.52)	5.60 (0.52)
Tube Size OD	in (mm)	7mm	5/16 (7.93)	5/16 (7.93)	5/16 (7.93)
Tube Type		Inn.Gr.	Inn. Grv.	Inn. Grv.	Inn. Grv.
Rows		1	1	1	2
Fin Type		Uncoated Corrugated			
Fins per inch		14	18	18	18
Refrigerant Flow Control		-	-	-	-
<b>FAN</b>					
Fan Type		Propeller	Propeller	Propeller	Propeller
No. used		1	1	1	1
Diameter	in (mm)	18(457.2)	18 (457.2)	18 (457.2)	18 (457.2)
No. of Blade		4	4	4	4
Pitch Angle	degree	25	25	25	30
Drive Type		Direct	Direct	Direct	Direct
Nominal Airflow <sup>2</sup>	cfm (cmh)	1490 (2532)	1360 (2311)	1360 (2311)	1600 (2717)
<b>MOTOR</b>					
Motor Type		Permanent Split Capacitor			
No. of Motor		1	1	1	1
Motor hp	hp (kW)	1/15 (0.052)	1/15 (0.052)	1/8 (0.098)	1/8 (0.098)
No. of Speed		1	1	1	1
Motor Speed	rpm	900	900	900	900
V/ph/Hz		220/1/50	220/1/50	220/1/50	220/1/50
RLA/LRA		0.46/0.93	0.46 / 0.93	0.8 / 1.79	0.8 / 1.79
<b>DIMENSION (HxWxD)<sup>4</sup></b>					
Crated (Shipping)	in	25.7 x 36.9 x 15.8		29.8 x 36.9 x 15.8	
	(mm)	(653 x 938 x 401)		(755 x 938 x 401)	
Uncrated (Net)	in	23.0 x 32.7 x 13.0		27.3 x 32.7 x 13.0	
	(mm)	585 x 830 x 330		(692 x 830 x 330)	
<b>WEIGHT</b>					
Crated (Shipping)	lb (kg)	87.5 (39.8)	126.3 (57.4)	138.8 (63.1)	144.5 (65.7)
Uncrated (Net)	lb (kg)	79.6 (36.2)	118.4 (53.8)	130.9 (59.5)	133.5 (60.7)

<sup>1</sup> MCA - Minimum Circuit Ampacity ; calculated as follow : 125 % of compressor R.L.Amps plus the condenser fan motor R.L.Amps.

<sup>2</sup> CFM is rated with standard air-dry coil.

<sup>3</sup> At ARI system rating conditions 80°F-DB/67°F-WB indoor & 95°F-DB outdoor

<sup>4</sup> For uncrated, outdoor unit's width and depth do not include the size of the mounting feet



# General Data

## General Data TTK 50 Hz

UNIT MODELS		TTK536KB	TTK536KD	TTK042KD	TTK048KD	TTK060KD
<b>POWER CONNECTION</b>	V/ph/Hz	220-240/1/50	380-415/3/50	380-415/3/50	380-415/3/50	380-415/3/50
<b>MCA<sup>1, 3</sup> A</b>		20.7	8.2	13.4	13.95	13.95
<b>SYSTEM DATA</b>						
Refrigerant Type		R-22	R-22	R-22	R-22	R-22
No. Refrigerant Circuits		1	1	1	1	1
Refrigerant Connection Type		Flare	Flare	Sweat	Sweat	Sweat
Refrigerant Charge	lb (kg)	6.61 (3.00)	6.61 (3.00)	7.49 (3.40)	6.61 (3.00)	8.82 (4.00)
Suction Line OD	in (mm)	3/4 (19.05)	3/4 (19.05)	7/8 (22.23)	1 1/8 (28.6)	1 1/8 (28.6)
Liquid line OD	in (mm)	3/8 (9.53)	3/8 (9.53)	3/8 (9.53)	3/8 (9.53)	3/8 (9.53)
<b>COMPRESSOR</b>						
Compressor Type		Rotary	Rotary	Scroll	Scroll	Scroll
No. Used		1	1	1	1	1
V/ph/Hz		220/1/50	380/3/50	380/3/50	380/3/50	380/3/50
RLA/LRA		15.8 / 79.0	5.85 / 43.0	10.0 / 56.0	10.0 / 59.0	10.0 / 74.0
<b>COIL</b>						
Face Area	sq ft (m <sup>2</sup> )	7.29 (0.68)	7.29 (0.68)	7.29 (0.68)	7.08 (0.66)	7.08 (0.66)
Tube Size OD	in (mm)	5/16 (7.93)	5/16 (7.93)	5/16 (7.93)	5/16 (7.93)	5/16 (7.93)
Tube Type		Inn. Grv.	Inn. Grv.	Inn. Grv.	Smooth	Inn. Grv.
Rows		2	2	2	3	3
Fin Type		Uncoated Corrugated				
Fins per inch		16	16	20	16	20
Refrigerant Flow Control		-	-	-	-	-
<b>FAN</b>						
Fan Type		Propeller	Propeller	Propeller	Propeller	Propeller
No. used		1	1	1	1	1
Diameter	in (mm)	20 (508)	20 (508)	20 (508)	20 (508)	20 (508)
No. of Blade		4	4	4	3	3
Pitch Angle	degree	30	30	30	32	32
Drive Type		Direct	Direct	Direct	Direct	Direct
Nominal Airflow <sup>2</sup>	cfm (cmh)	2130 (3619)	2130 (3619)	2130 (3619)	1903 (3233)	1903 (3233)
<b>Permanent Split Capacitor</b>						
<b>No. of Motor</b>		1	1	1	1	1
Motor hp	hp (kW)	1/6 (0.102)	1/6 (0.102)	1/6 (0.102)	1/4 (0.165)	1/4 (0.165)
No. of Speed		1	1	1	1	1
Motor Speed	rpm	900	900	900	900	900
V/ph/Hz		220/1/50	220/1/50	220/1/50	230/1/50	230/1/50
RLA/LRA		0.9 / 1.79	0.9 / 1.79	0.9 / 1.79	1.45 / 2.68	1.45 / 2.68
<b>DIMENSION (HxWxD)<sup>4</sup></b>						
Crated (Shipping)	in (mm)	33.8 x 45.0 x 16.9 (858 x 1,144 x 430)				
Uncrated (Net)	in (mm)	31.3 x 40.0 x 14.2 (795 x 1,018 x 360)				
<b>WEIGHT</b>						
Crated (Shipping)	lb (kg)	188.1 (85.5)	188.1 (85.5)	207.7 (94.4)	222.4 (101.1)	229.0 (104.1)
Uncrated (Net)	lb (kg)	172.3 (78.3)	172.3 (78.3)	191.8 (87.2)	200.4 (91.1)	207.0 (94.1)

<sup>1</sup> MCA - Minimum Circuit Ampacity ; calculated as follow : 125 % of compressor R.L.Amps plus the condenser fan motor R.L.Amps.

<sup>2</sup> CFM is rated with standard air-dry coil.

<sup>3</sup> At ARI system rating conditions 80°F-DB/67°F-WB indoor & 95°F-DB outdoor.

<sup>4</sup> For uncrated, outdoor unit's width and depth do not include the size of the mounting feet.



# General Data

## General Data TTK 60 Hz

UNIT MODELS		TTK512L1	TTK518P1	TTK524P1	TTK530P1
<b>POWER CONNECTION</b>		200-240/1/60	200-240/1/60	200-240/1/60	200-240/1/60
	V/ph/Hz				
MCA <sup>1,3</sup>	A	7.16	11.94	14.75	18.9
<b>SYSTEM DATA</b>					
Refrigerant Type		R-22	R-22	R-22	R-22
No. Refrigerant Circuits		1	1	1	1
Refrigerant Connection Type		Flare	Flare	Flare	Flare
Refrigerant Charge		2.64 (1.20)	2.60 (1.18)	3.75 (1.70)	5.51 (2.50)
	lb (kg)				
Suction Line OD		1/2 (12.7)	1/2 (12.7)	5/8 (15.88)	5/8 (15.88)
	in (mm)				
Liquid line OD		1/4 (6.35)	1/4 (6.53)	3/8 (9.53)	3/8 (9.53)
	in (mm)				
<b>COMPRESSOR</b>					
Compressor Type		Rotary	Rotary	Rotary	Rotary
No. Used		1	1	1	1
V/ph/Hz		220/1/60	220/1/60	220/1/60	220/1/60
RLA/LRA		5.2 / 29.0	8.55 / 50.0	10.8 / 58.0	14.1 / 78.0
<b>COIL</b>					
Face Area		3.0 (0.28)	5.60 (0.52)	5.60 (0.52)	5.60 (0.52)
	sq ft (m <sup>2</sup> )				
Tube Size OD		7mm	5/16 (7.93)	5/16 (7.93)	5/16 (7.93)
	in (mm)				
Tube Type		Inn. Grv.	Inn. Grv.	Inn. Grv.	Inn. Grv.
Rows		1	1	1	2
Fin Type		Uncoated Louver		Uncoated Corrugated	
Fins per inc		14	18	18	18
Refrigerant Flow Control		-	-	-	-
<b>FAN</b>					
Fan Type		Propeller	Propeller	Propeller	Propeller
No. used		1	1	1	1
Diameter		18 (457.2)	18 (457.2)	18 (457.2)	18 (457.2)
	in (mm)				
No. of Blade		4	4	4	4
Pitch Angle		25	30	30	30
	degree				
Drive Type		Direct	Direct	Direct	Direct
Nominal Airflow <sup>2</sup>		1490 (2532)	1600 (2717)	1600 (2717)	1600 (2717)
	cfm (cmh)				
<b>MOTOR</b>					
Motor Type		Permanent Split Capacitor			
No. of Motor		1	1	1	1
Motor hp		1/15 (0.037)	1/6 (0.104)	1/6 (0.104)	1/6 (0.104)
	hp (kW)				
No. of Speed		1	1	1	1
Motor Speed		900	900	900	900
	rpm				
V/ph/Hz		220 /1/ 60	220 /1/60	220 /1/60	220 /1/60
RLA/LRA		0.66 / 0.80	1.25 / 1.53	1.25 / 1.53	1.25 / 1.53
<b>DIMENSION (HxWxD)<sup>4</sup></b>					
Crated (Shipping)		22.4 x 29.9 x 15.4		29.8 x 36.9 x 15.8	
	in				
	(mm)	(570 x 760 x 390)		(755 x 938 x 401)	
Uncrated (Net)		20.9 x 27.6 x 9.8		27.3 x 32.7 x 13.0	
	in				
	(mm)	(530 x 700 x 250)		(692 x 830 x 330)	
<b>WEIGHT</b>					
Crated (Shipping)		83.6 (38.0)	107.0 (48.5)	127.3 (47.8)	144.5 (65.7)
	lb (kg)				
Uncrated (Net)		79.2 (36.0)	95.9 (43.5)	116.3 (42.8)	133.5 (60.7)
	lb (kg)				

<sup>1</sup> MCA - Minimum Circuit Ampacity ; calculated as follow : 125 % of compressor R.L.Amps plus the condenser fan motor R.L.Amps.

<sup>2</sup> CFM is rated with standard air-dry coil.

<sup>3</sup> At ARI system rating conditions 80°F-DB/67°F-WB indoor & 95°F-DB outdoor

<sup>4</sup> For uncrated, outdoor unit's width and depth do not include the size of the mounting feet



# General Data

## General Data TTK 60 Hz

UNIT MODELS		TTK536K1	TTK536K4	TTK042K4	TTK048K4	TTK060K4
<b>POWER CONNECTION</b>		V/ph/Hz	200-240/1/60	460/3/60	460/3/60	460/3/60
MCA <sup>1, 3</sup>		A	20.1	8.4	10.1	10.3
<b>SYSTEM DATA</b>						
Refrigerant Type		R-22	R-22	R-22	R-22	R-22
No. Refrigerant Circuits		1	1	1	1	1
Refrigerant Connection Type		Flare	Flare	Sweat	Sweat	Sweat
Refrigerant Charge	lb (kg)	6.61 (3.0)	7.48 (3.40)	8.14 (3.70)	11.46 (5.20)	11.46 (5.20)
Suction Line OD	in (mm)	3/4 (19.05)	3/4 (19.05)	7/8 (22.23)	1 1/8 (28.6)	1 1/8 (28.6)
Liquid line OD	in (mm)	3/8 (9.53)	3/8 (9.53)	3/8 (9.53)	3/8 (9.53)	3/8 (9.53)
<b>COMPRESSOR</b>						
Compressor Type		Rotary	Scroll	Scroll	Scroll	Scroll
No. Used		1	1	1	1	1
V/ph/Hz		220/1/60	460/3/60	460/3/60	460/3/60	460/3/60
RLA/LRA		15.1 / 81.0	5.7 / 39.0	7.1 / 44.0	7.2 / 46.0	10.0 / 63.0
<b>COIL</b>						
Face Area	sq ft (m <sup>2</sup> )	7.29 (0.68)	7.29 (0.68)	7.29 (0.68)	11.67 (1.08)	11.67 (1.08)
Tube Size OD	in (mm)	5/16 (7.93)	5/16 (7.93)	5/16 (7.93)	5/16 (7.93)	5/16 (7.93)
Tube Type		Inn. Grv.	Inn. Grv.	Inn. Grv.	Smooth	Inn. Grv.
Rows		2	2	2	2	2
Fin Type		Uncoated Corrugated				
Fins per inch		16	16	20	17	21
Refrigerant Flow Control		-	-	-	-	-
<b>FAN</b>						
Fan Type		Propeller	Propeller	Propeller	Propeller	Propeller
No. used		1	1	1	2	2
Diameter	in (mm)	20 (508)	20 (508)	20 (508)	18 (457.2)	18 (457.2)
No. of Blade		4	4	4	4	4
Pitch Angle	degree	30	30	30	25	25
Drive Type		Direct	Direct	Direct	Direct	Direct
Nominal Airflow <sup>2</sup>	cfm (cmh)	2130 (3619)	2130 (3619)	2130 (3619)	2690 (4570)	2690 (4570)
<b>MOTOR</b>						
Motor Type		Permanent Split Capacitor				
No. of Motor		1	1	1	2	2
Motor hp	hp (kW)	1/6 (0.104)	1/6 (0.104)	1/6 (0.104)	1/15 (0.043)	1/15 (0.043)
No. of Speed		1	1	1	1	1
Motor Speed	rpm	900	900	900	900	900
V/ph/Hz		220/1/60	220/1/60	220/1/60	220/1/60	220/1/60
RLA/LRA		1.25 / 1.53	1.25 / 1.53	1.25 / 1.53	0.66 / 0.80	0.66 / 0.80
<b>DIMENSION (HxWxD)<sup>4</sup></b>						
Crated (Shipping)	in (mm)	33.8 x 45.0 x 16.9 (858 x 1,144 x 430)			55.3 x 42.7 x 14.9 (1,405 x 1,086 x 380)	
Uncrated (Net)	in (mm)	31.3 x 40.0 x 14.2 (795 x 1,018 x 360)			49.4 x 38.9 x 13.8 (1,254 x 988 x 350)	
<b>WEIGHT</b>						
Crated (Shipping)	lb (kg)	194.7 (88.5)	186.9 (86.2)	194.9 (88.6)	206.6 (93.9)	224.0 (101.8)
Uncrated (Net)	lb (kg)	178.9 (81.3)	173.8 (79.0)	179.1 (81.4)	184.6 (83.9)	202.0 (91.8)

<sup>1</sup> MCA - Minimum Circuit Ampacity ; calculated as follow : 125 % of compressor R.L.Amps plus the condenser fan motor R.L.Amps.

<sup>2</sup> CFM is rated with standard air-dry coil.

<sup>3</sup> At ARI system rating conditions 80°F-DB/67°F-WB indoor & 95°F-DB outdoor

<sup>4</sup> For uncrated, outdoor unit's width and depth do not include the size of the mounting feet

# Fan Performance Data

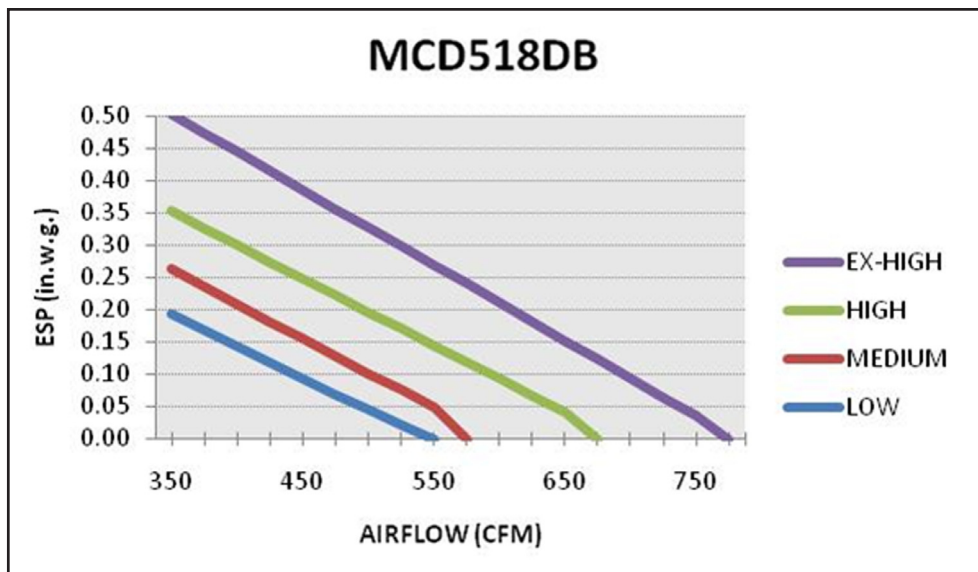
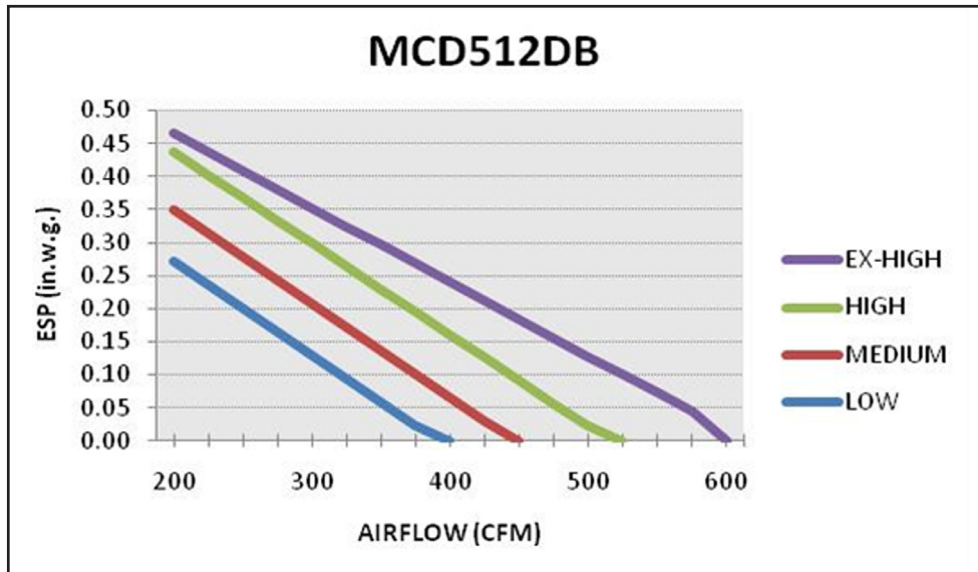

## Fan Performance Data

---

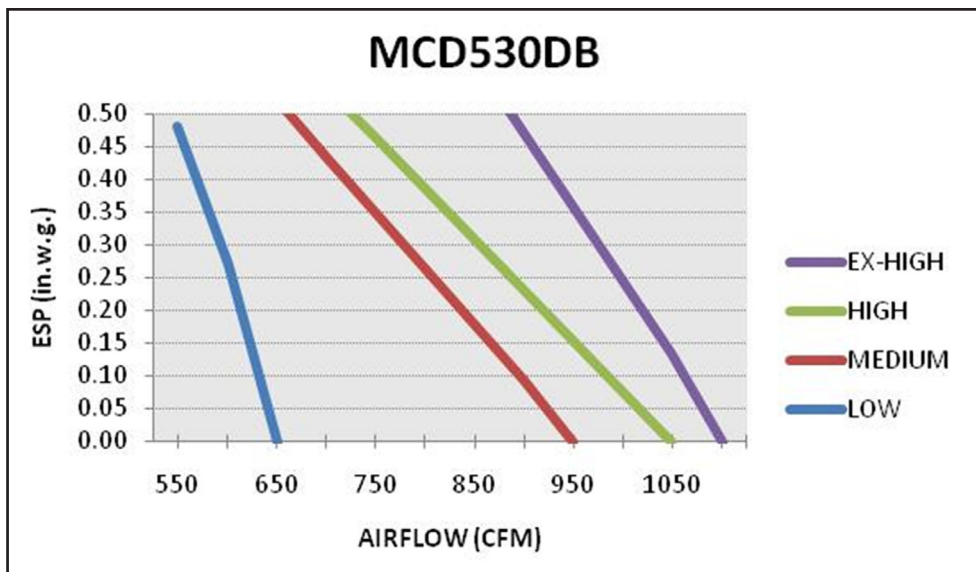
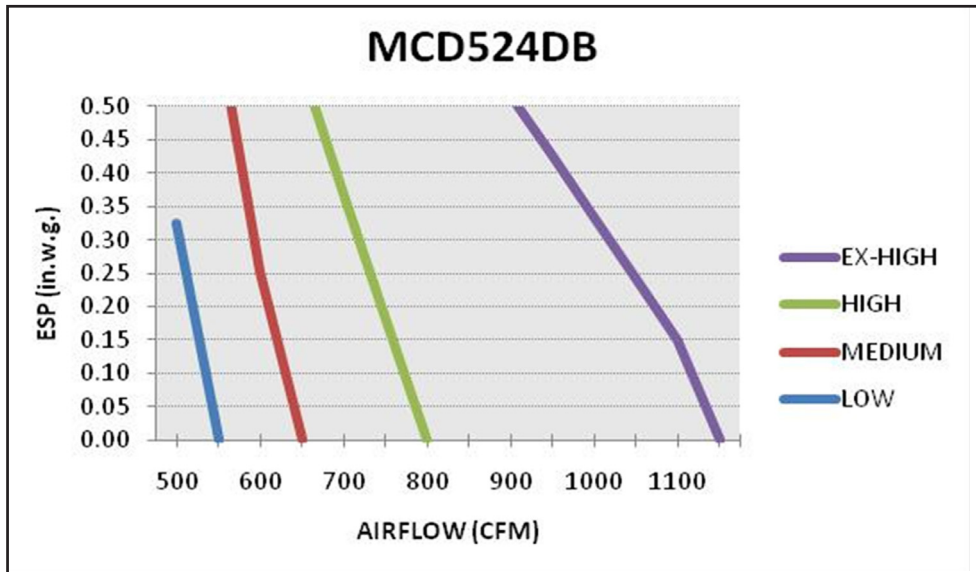

# Fan Performance Data

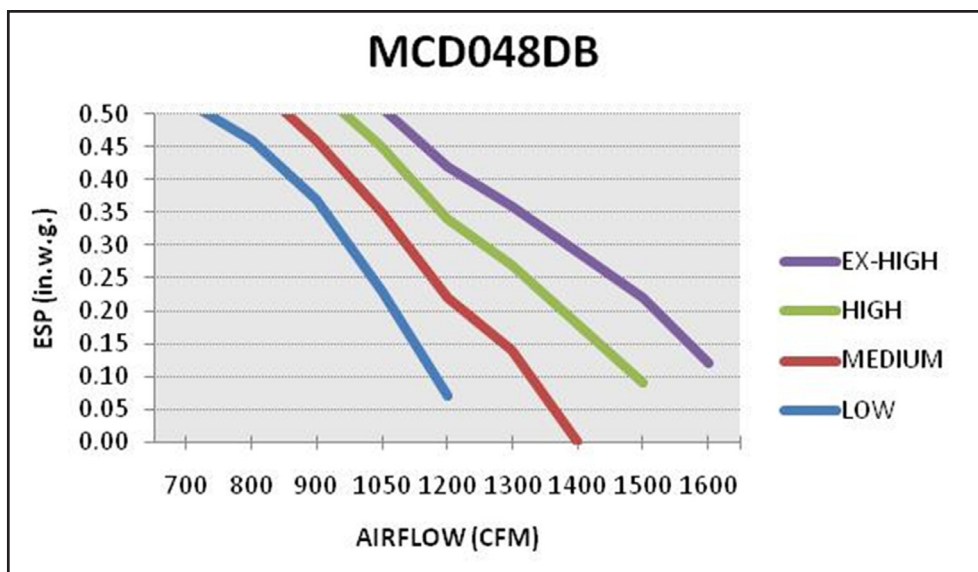
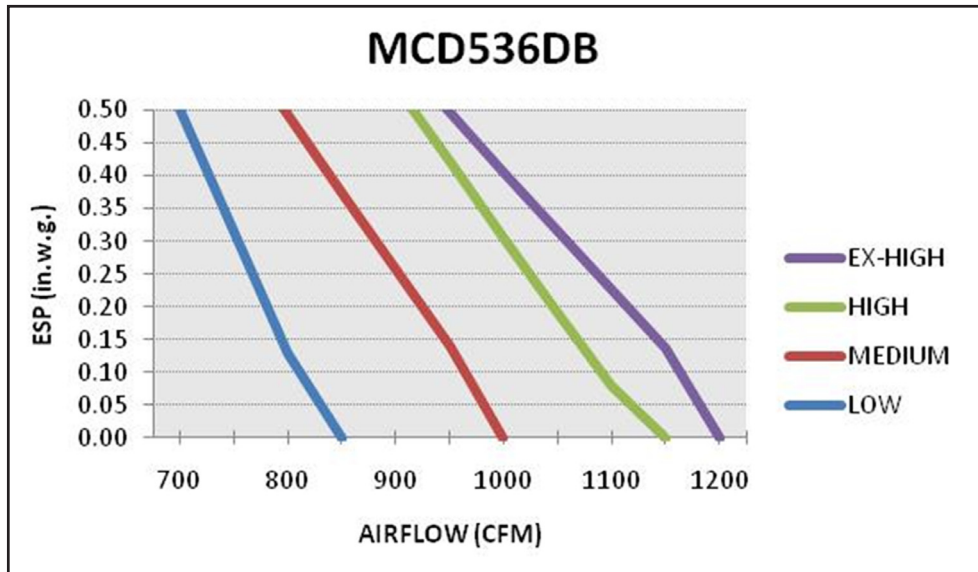

## Fan Performance Data

---

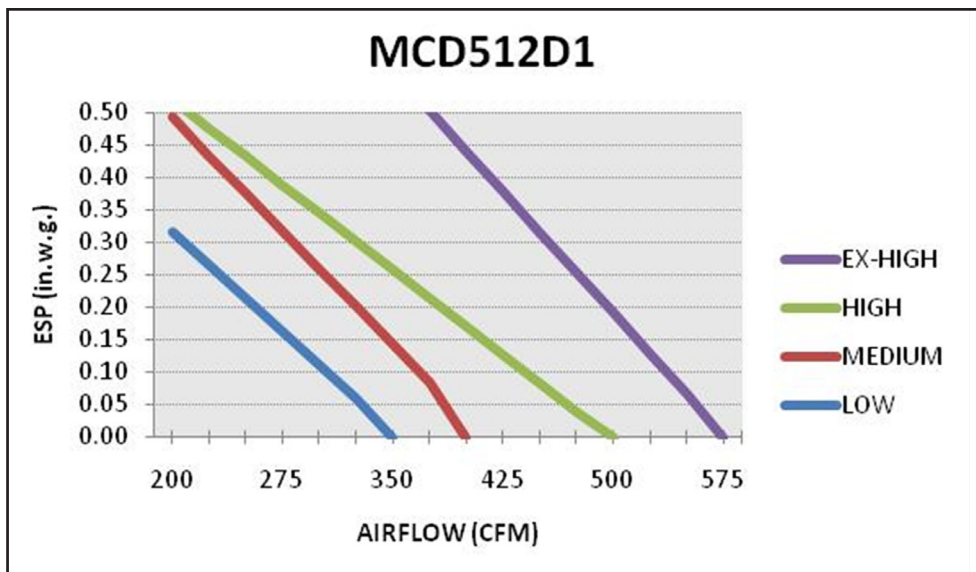
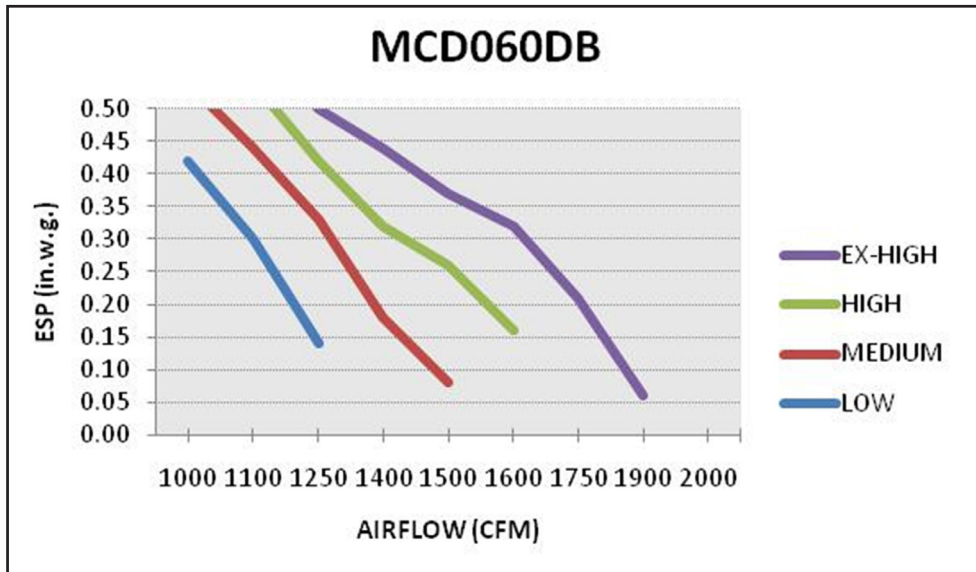

## Fan Performance Data

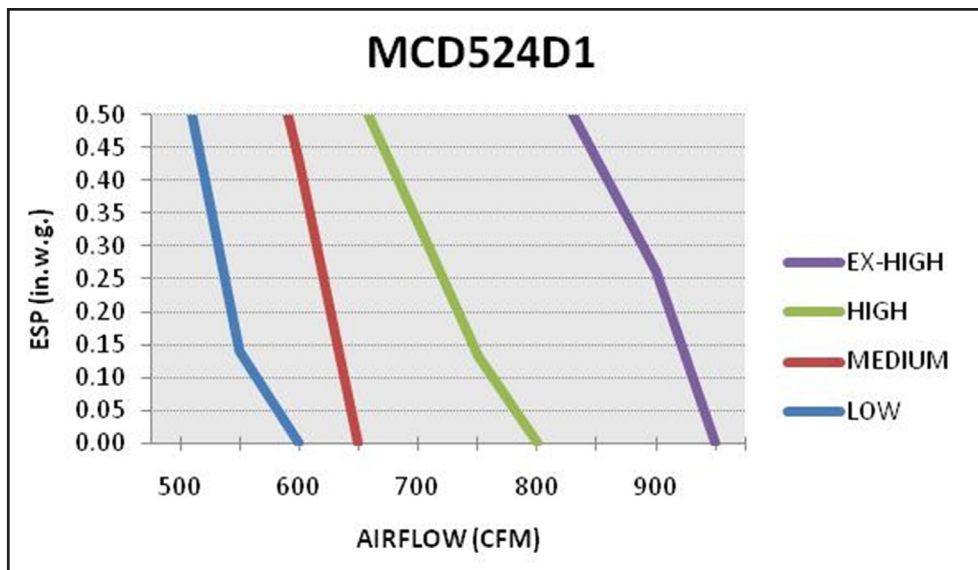
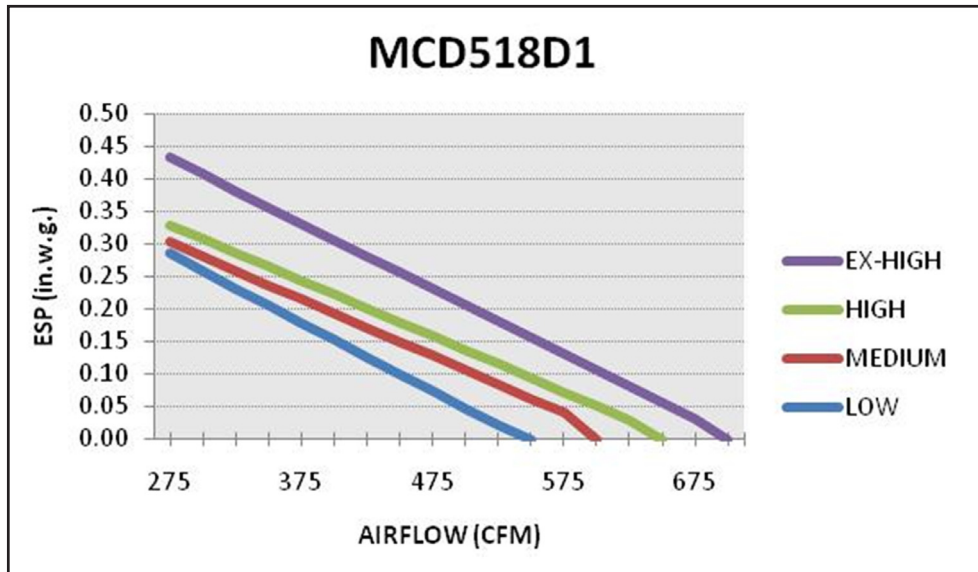

## Fan Performance Data

---

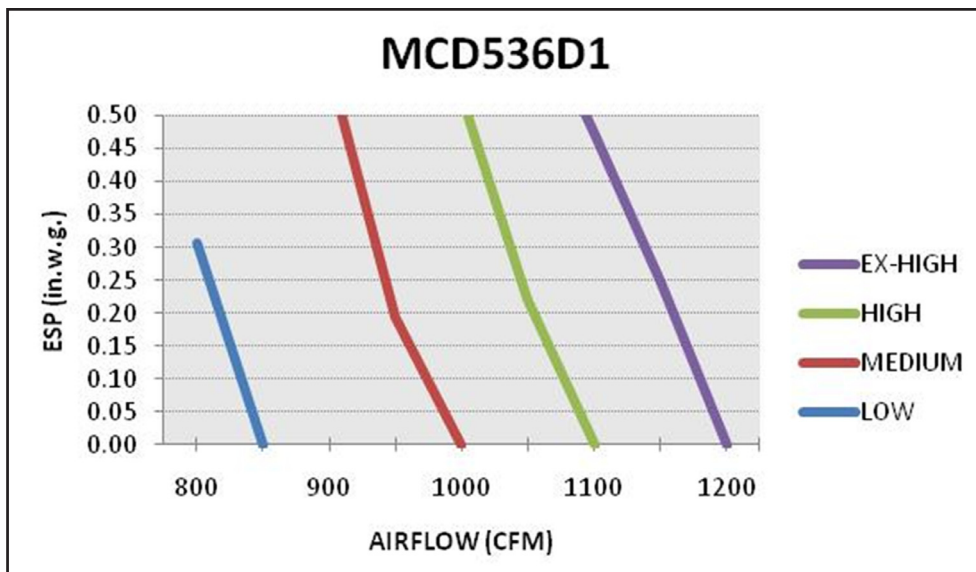
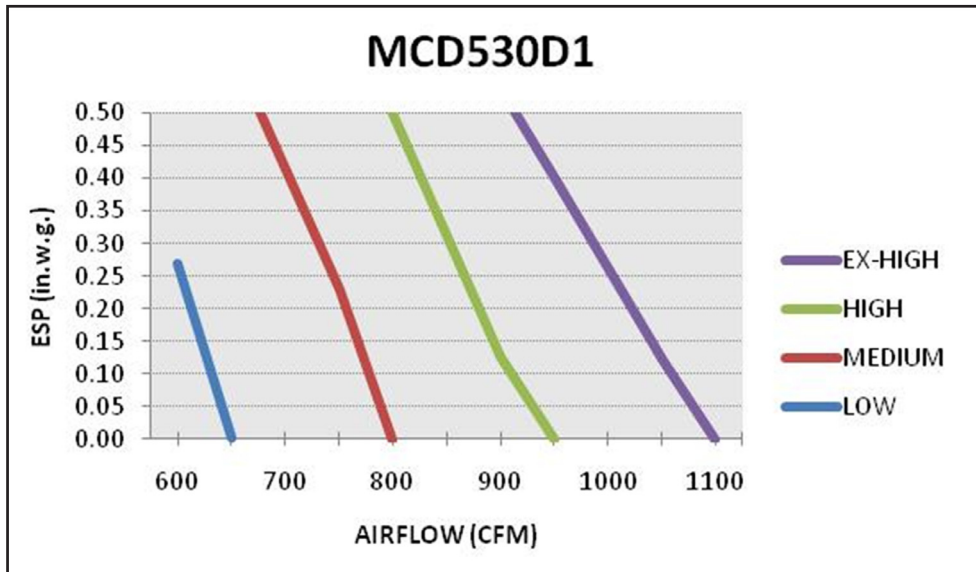



## Fan Performance Data

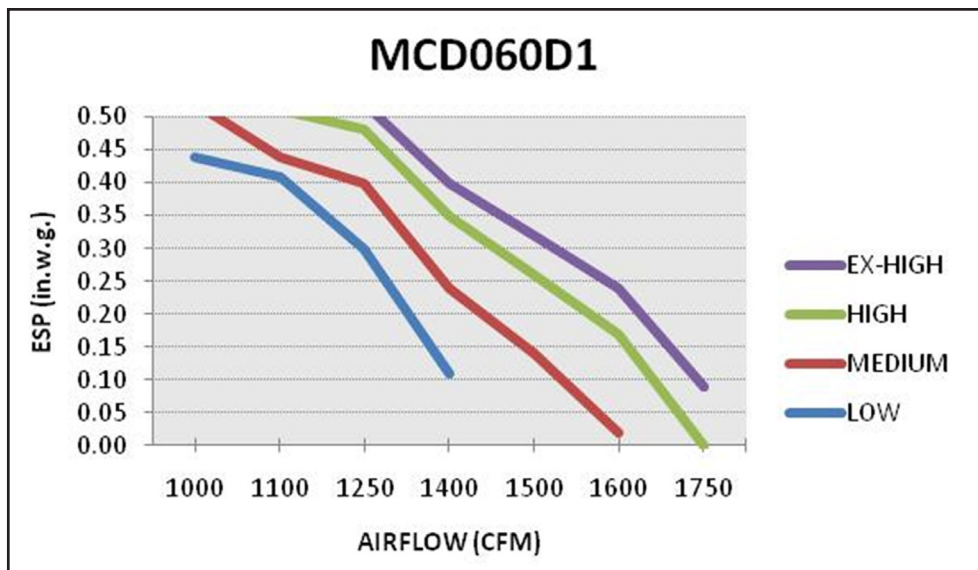
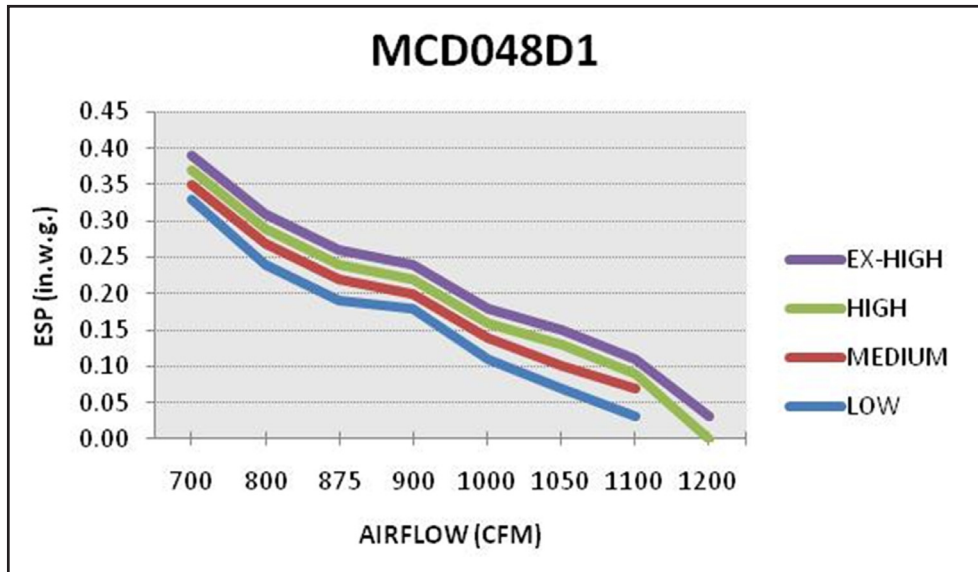



# System Performance Data

## Cooling

### English Units

**TTK509LB5 WITH MCD009AA5  
AT 300 CFM  
GROSS CAPACITY IN BTU/H x 1000**

OUTDOOR D.B.	I.D. W.B.	GROSS CAP.	SENS. CAP. AT ENTERING D.B. TEMP.					COMPR. KW
			72	74	76	78	80	
85	61	9.7	7.6	8.3	8.9	9.5	9.9*	0.67
	65	10.5	6.3	7.0	7.6	8.2	8.9	0.70
	67	10.9	5.6	6.3	6.9	7.5	8.2	0.71
	71	11.7	4.2	4.9	5.5	6.2	6.8	0.74
95	61	9.5	7.5	8.1	8.8	9.3	9.9*	0.73
	65	10.2	6.2	6.8	7.5	8.1	8.8	0.76
	67	10.6	5.5	6.1	6.8	7.4	8.1	0.78
	71	11.4	4.1	4.7	5.4	6.0	6.7	0.81
105	61	9.1	7.2	7.9	8.5	9.0	9.5*	0.80
	65	9.8	5.9	6.6	7.2	7.8	8.5	0.83
	67	10.2	5.2	5.9	6.5	7.1	7.8	0.84
	71	10.9	4.5	4.5	5.1	5.8	6.4	0.87
115	61	8.7	7.0	7.6	8.2	8.7*	9.2*	0.86
	65	9.4	5.7	6.4	7.0	7.6	8.3	0.89
	67	9.8	5.0	5.7	6.3	6.9	7.6	0.91
	71	10.5	3.6	4.3	4.9	5.6	6.2	0.94

\* Dry coil condition (Gross Capacity = Sensible Capacity)  
Gross Capacity and Comp. kW are valid only for Wet Coil

Performance at the Rating Conditions of 80/67 & 95 °F  
 GROSS CAPACITY: 10.6 MBH  
 AIRFLOW: 300 CFM  
 SYSTEM POWER: 929 WATTS  
 NOM. SYSTEM AMPS: 4.3 AMPS  
 All temperature in Degree F

**TTK512LB5 WITH MCD012AA5  
AT 400 CFM  
GROSS CAPACITY IN BTU/H x 1000**

OUTDOOR D.B.	I.D. W.B.	GROSS CAP.	SENS. CAP. AT ENTERING D.B. TEMP.					COMPR. KW
			72	74	76	78	80	
85	61	12.3	8.3	9.0	9.7	10.4	10.8	0.81
	65	13.3	6.9	7.6	8.3	9.0	9.7	0.85
	67	13.8	6.1	6.8	7.5	8.2	8.9	0.86
	71	14.8	4.6	5.3	6.0	6.7	7.4	0.90
95	61	12.0	8.2	8.8	9.6	10.2	10.7	0.88
	65	12.9	6.7	7.4	8.1	8.8	9.5	0.92
	67	13.4	6.0	6.7	7.4	8.1	8.8	0.94
	71	14.4	4.4	5.1	5.9	6.5	7.3	0.97
105	61	11.5	7.9	8.6	9.2	9.8	10.4	0.96
	65	12.4	6.4	7.1	7.9	8.5	9.2	1.00
	67	12.9	5.7	6.4	7.1	7.8	8.5	1.02
	71	13.8	4.9	4.9	5.6	6.3	7.0	1.06
115	61	11.0	7.6	8.3	8.9	9.5	10.0	1.04
	65	11.9	6.2	6.9	7.6	8.3	9.0	1.08
	67	12.3	5.5	6.2	6.9	7.6	8.3	1.10
	71	13.3	4.0	4.7	5.3	6.1	6.8	1.14

\* Dry coil condition (Gross Capacity = Sensible Capacity)  
Gross Capacity and Comp. kW are valid only for Wet Coil

Performance at the Rating Conditions of 80/67 & 95 °F  
 GROSS CAPACITY: 13.4 MBH  
 AIRFLOW: 400 CFM  
 SYSTEM POWER: 1120 WATTS  
 NOM. SYSTEM AMPS: 5.3 AMPS  
 All temperature in Degree F



# System Performance Data

## Cooling

### English Units

**TTK518LB5 WITH MCD018AA5  
AT 600 CFM  
GROSS CAPACITY IN BTU/H x 1000**

OUTDOOR D.B.	I.D. W.B.	GROSS CAP.	SENS. CAP. AT ENTERING D.B. TEMP.					COMPR. KW
			72	74	76	78	80	
85	61	16.6	13.3	14.5	15.6	16.6*	17.3*	1.19
	65	18.0	11.0	12.2	13.3	14.4	15.6	1.24
	67	18.7	9.8	11.0	12.1	13.2	14.4	1.26
	71	20.0	7.3	8.5	9.6	10.8	11.9	1.31
95	61	16.2	13.1	14.2	15.4	16.3*	17.3*	1.29
	65	17.4	10.8	11.9	13.1	14.2	15.3	1.34
	67	18.1	9.6	10.7	11.9	13.0	14.1	1.37
	71	19.5	7.2	8.3	9.4	10.5	11.7	1.42
105	61	15.5	12.6	13.8	14.8	15.7*	16.6*	1.40
	65	16.8	10.4	11.5	12.6	13.7	14.9	1.46
	67	17.4	9.2	10.3	11.4	12.5	13.7	1.49
	71	18.7	7.8	7.9	9.0	10.1	11.2	1.54
115	61	14.9	12.3	13.4	14.4	15.3*	16.1*	1.52
	65	16.0	10.0	11.1	12.2	13.4	14.5	1.58
	67	16.7	8.8	10.0	11.0	12.2	13.3	1.61
	71	17.9	6.4	7.5	8.6	9.7	10.9	1.66

\* Dry coil condition (Gross Capacity = Sensible Capacity)  
Gross Capacity and Comp. kW are valid only for Wet Coil

Performance at the Rating Conditions of 80/67 & 95 °F  
 GROSS CAPACITY: 18.1 MBH  
 AIRFLOW: 600 CFM  
 SYSTEM POWER: 1575 WATTS  
 NOM. SYSTEM AMPS: 7.4 AMPS  
 All temperature in Degree F

**TTK524LB5 WITH MCD024AA5  
AT 800 CFM  
GROSS CAPACITY IN BTU/H x 1000**

OUTDOOR D.B.	I.D. W.B.	GROSS CAP.	SENS. CAP. AT ENTERING D.B. TEMP.					COMPR. KW
			72	74	76	78	80	
85	61	23.4	18.8	20.5	22.0	23.6*	24.5*	1.52
	65	25.2	15.6	17.2	18.8	20.4	22.0	1.58
	67	26.2	13.9	15.5	17.1	18.7	20.3	1.61
	71	28.1	10.4	12.0	13.6	15.3	16.8	1.68
95	61	22.7	18.6	20.1	21.8	23.1*	24.5*	1.65
	65	24.5	15.3	16.9	18.5	20.1	21.7	1.72
	67	25.4	13.5	15.2	16.8	18.4	20.0	1.75
	71	27.3	10.1	11.7	13.3	14.9	16.6	1.82
105	61	21.8	17.9	19.5	21.0	22.3*	23.6*	1.80
	65	23.5	14.7	16.2	17.9	19.4	21.0	1.87
	67	24.5	13.0	14.5	16.1	17.7	19.3	1.90
	71	26.2	11.1	11.1	12.7	14.3	15.9	1.98
115	61	20.8	17.4	18.9	20.3	21.7*	22.8*	1.94
	65	22.5	14.1	15.7	17.3	18.9	20.5	2.02
	67	23.4	12.4	14.1	15.6	17.2	18.8	2.05
	71	25.1	9.0	10.6	12.2	13.8	15.4	2.13

\* Dry coil condition (Gross Capacity = Sensible Capacity)  
Gross Capacity and Comp. kW are valid only for Wet Coil

Performance at the Rating Conditions of 80/67 & 95 °F  
 GROSS CAPACITY: 25.4 MBH  
 AIRFLOW: 800 CFM  
 SYSTEM POWER: 2202 WATTS  
 NOM. SYSTEM AMPS: 10.3 AMPS  
 All temperature in Degree F



# System Performance Data

## Cooling

English Units

### TTK530KB5 WITH MCD030EB5 AT 1000 CFM GROSS CAPACITY IN BTU/H x 1000

OUTDOOR D.B.	I.D. W.B.	GROSS CAP.	SENS. CAP. AT ENTERING D.B. TEMP.					COMPR. KW
			72	74	76	78	80	
85	61	28.6	17.0	18.5	19.9	21.3	22.1	1.95
	65	30.9	14.1	15.6	17.0	18.5	19.9	2.03
	67	32.1	12.5	14.0	15.5	16.9	18.3	2.07
	71	34.4	9.4	10.9	12.3	13.8	15.2	2.15
95	61	27.8	16.8	18.2	19.7	20.9	22.1	2.11
	65	30.0	13.8	15.2	16.7	18.1	19.6	2.20
	67	31.1	12.2	13.7	15.2	16.6	18.0	2.25
	71	33.4	9.1	10.5	12.0	13.4	15.0	2.33
105	61	26.7	16.1	17.6	19.0	20.1	21.3	2.31
	65	28.8	13.2	14.7	16.1	17.5	19.0	2.39
	67	29.9	11.7	13.1	14.6	16.0	17.5	2.44
	71	32.1	10.0	10.1	11.5	12.9	14.4	2.53
115	61	25.5	15.7	17.1	18.4	19.6	20.6	2.49
	65	27.6	12.8	14.2	15.6	17.1	18.5	2.59
	67	28.6	11.2	12.7	14.1	15.6	17.0	2.64
	71	30.8	8.2	9.6	11.0	12.4	13.9	2.73

\* Dry coil condition (Gross Capacity = Sensible Capacity)  
Gross Capacity and Comp. kW are valid only for Wet Coil

Performance at the Rating Conditions of 80/67 & 95 °F

GROSS CAPACITY: 31.1 MBH  
AIRFLOW: 1000 CFM  
SYSTEM POWER: 2720 WATTS  
NOM. SYSTEM AMPS: 12.5 AMPS

All temperature in Degree F

### TTK536KB5 WITH MCD036EB5 AT 1200 CFM GROSS CAPACITY IN BTU/H x 1000

OUTDOOR D.B.	I.D. W.B.	GROSS CAP.	SENS. CAP. AT ENTERING D.B. TEMP.					COMPR. KW
			72	74	76	78	80	
85	61	33.2	24.9	27.1	29.1	31.1	32.3	2.44
	65	35.8	20.6	22.8	24.9	27.0	29.1	2.54
	67	37.2	18.4	20.5	22.6	24.7	26.8	2.59
	71	40.0	13.7	15.9	17.9	20.2	22.2	2.69
95	61	32.3	24.6	26.6	28.8	30.5	32.3*	2.65
	65	34.8	20.2	22.3	24.5	26.5	28.7	2.75
	67	36.1	17.9	20.1	22.2	24.3	26.4	2.81
	71	38.8	13.4	15.4	17.6	19.7	21.9	2.92
105	61	30.9	23.6	25.7	27.7	29.4	31.1*	2.89
	65	33.4	19.4	21.5	23.6	25.7	27.8	3.00
	67	34.8	17.1	19.2	21.3	23.4	25.6	3.05
	71	37.2	14.7	14.7	16.8	18.9	21.0	3.17
115	61	29.6	23.0	25.0	26.9	28.6	30.1*	3.12
	65	32.0	18.7	20.8	22.9	25.0	27.0	3.24
	67	33.2	16.4	18.6	20.6	22.8	24.8	3.30
	71	35.7	11.9	14.0	16.1	18.2	20.3	3.42

\* Dry coil condition (Gross Capacity = Sensible Capacity)  
Gross Capacity and Comp. kW are valid only for Wet Coil

Performance at the Rating Conditions of 80/67 & 95 °F

GROSS CAPACITY: 36.1 MBH  
AIRFLOW: 1200 CFM  
SYSTEM POWER: 3205 WATTS  
NOM. SYSTEM AMPS: 15.7 AMPS

All temperature in Degree F



# System Performance Data

## Cooling

### English Units

**TTK536KD5 WITH MCD036EB5  
AT 1200 CFM  
GROSS CAPACITY IN BTU/H x 1000**

OUTDOOR D.B.	I.D. W.B.	GROSS CAP.	SENS. CAP. AT ENTERING D.B. TEMP.					COMPR. KW
			72	74	76	78	80	
85	61	33.3	27.6	30.1	32.3	34.5*	35.9*	2.41
	65	35.9	22.9	25.3	27.6	30.0	32.3	2.51
	67	37.3	20.4	22.7	25.1	27.4	29.8	2.56
	71	40.1	15.2	17.6	19.9	22.4	24.7	2.67
95	61	32.4	27.3	29.5	31.9	33.9*	35.9*	2.62
	65	34.9	22.4	24.7	27.1	29.4	31.8	2.72
	67	36.2	19.9	22.3	24.6	27.0	29.3	2.78
	71	38.9	14.8	17.1	19.5	21.8	24.3	2.89
105	61	31.0	26.2	28.6	30.8	32.7*	34.5*	2.86
	65	33.5	21.5	23.8	26.2	28.5	30.9	2.96
	67	34.9	19.0	21.3	23.7	26.0	28.4	3.02
	71	37.3	16.3	16.3	18.6	21.0	23.3	3.14
115	61	29.7	25.5	27.8	29.8*	31.8*	33.4*	3.09
	65	32.1	20.7	23.1	25.4	27.7	30.0	3.21
	67	33.3	18.2	20.7	22.9	25.3	27.5	3.26
	71	35.8	13.2	15.5	17.8	20.2	22.5	3.38

\* Dry coil condition (Gross Capacity = Sensible Capacity)  
Gross Capacity and Comp. kW are valid only for Wet Coil

Performance at the Rating Conditions of 80/67 & 95 °F  
 GROSS CAPACITY: 36.2 MBH  
 AIRFLOW: 1200 CFM  
 SYSTEM POWER: 3175 WATTS  
 NOM. SYSTEM AMPS: 7.3 AMPS  
 All temperature in Degree F

**TTK042KD5 WITH MCD042EB5  
AT 1400 CFM  
GROSS CAPACITY IN BTU/H x 1000**

OUTDOOR D.B.	I.D. W.B.	GROSS CAP.	SENS. CAP. AT ENTERING D.B. TEMP.					COMPR. KW
			72	74	76	78	80	
85	61	37.6	29.3	31.9	34.3	36.7	38.1*	2.47
	65	40.6	24.3	26.8	29.3	31.8	34.3	2.57
	67	42.2	21.6	24.1	26.7	29.1	31.6	2.62
	71	45.3	16.2	18.7	21.1	23.8	26.2	2.72
95	61	36.6	28.9	31.3	33.9	36.0	38.1*	2.68
	65	39.4	23.8	26.2	28.8	31.2	33.8	2.78
	67	40.9	21.1	23.6	26.1	28.6	31.1	2.84
	71	44.0	15.8	18.2	20.7	23.2	25.8	2.95
105	61	35.1	27.8	30.3	32.7	34.7	36.7*	2.92
	65	37.9	22.8	25.3	27.8	30.2	32.8	3.03
	67	39.4	20.2	22.6	25.1	27.6	30.1	3.08
	71	42.2	17.3	17.3	19.8	22.3	24.7	3.21
115	61	33.6	27.1	29.5	31.7	33.7*	35.5*	3.16
	65	36.2	22.0	24.5	26.9	29.4	31.9	3.28
	67	37.6	19.3	21.9	24.3	26.8	29.2	3.33
	71	40.5	14.1	16.5	18.9	21.5	23.9	3.45

\* Dry coil condition (Gross Capacity = Sensible Capacity)  
Gross Capacity and Comp. kW are valid only for Wet Coil

Performance at the Rating Conditions of 80/67 & 95 °F  
 GROSS CAPACITY: 40.9 MBH  
 AIRFLOW: 1400 CFM  
 SYSTEM POWER: 3444 WATTS  
 NOM. SYSTEM AMPS: 8.3 AMPS  
 All temperature in Degree F



# System Performance Data

## Cooling

### English Units

**TTK512LB WITH MCD512DB  
AT 400 CFM  
GROSS CAPACITY IN BTU/H x 1000**

OUTDOOR D.B.	I.D. W.B.	GROSS CAP.	SENS. CAP. AT ENTERING D.B. TEMP.					COMPR. KW
			72	74	76	78	80	
85	61	11.9	8.9	9.6	10.4	11.1	11.5	1.20
	65	12.8	7.3	8.1	8.9	9.6	10.4	1.25
	67	13.3	6.5	7.3	8.1	8.8	9.6	1.27
	71	14.3	4.9	5.7	6.4	7.2	7.9	1.32
95	61	11.5	8.7	9.5	10.2	10.9	11.5	1.30
	65	12.4	7.2	7.9	8.7	9.4	10.2	1.35
	67	12.9	6.4	7.1	7.9	8.6	9.4	1.38
	71	13.9	4.8	5.5	6.3	7.0	7.8	1.43
105	61	11.1	8.4	9.2	9.9	10.5	11.1*	1.42
	65	12.0	6.9	7.6	8.4	9.1	9.9	1.47
	67	12.4	6.1	6.8	7.6	8.3	9.1	1.50
	71	13.3	5.2	5.2	6.0	6.7	7.5	1.56
115	61	10.6	8.2	8.9	9.6	10.2	10.7*	1.53
	65	11.4	6.6	7.4	8.1	8.9	9.6	1.59
	67	11.9	5.8	6.6	7.3	8.1	8.8	1.62
	71	12.8	4.2	5.0	5.7	6.5	7.2	1.68

\* Dry coil condition (Gross Capacity = Sensible Capacity)  
Gross Capacity and Comp. kW are valid only for Wet Coil

Performance at the Rating Conditions of 80/67 & 95 °F  
 GROSS CAPACITY: 12.9 MBH  
 AIRFLOW: 300 CFM  
 SYSTEM POWER: 1570 WATTS  
 NOM. SYSTEM AMPS: 7.2 AMPS  
 All temperature in Degree F

**TTK518PB WITH MCD518DB  
AT 600 CFM  
GROSS CAPACITY IN BTU/H x 1000**

OUTDOOR D.B.	I.D. W.B.	GROSS CAP.	SENS. CAP. AT ENTERING D.B. TEMP.					COMPR. KW
			72	74	76	78	80	
85	61	16.9	10.7	11.7	12.6	13.4	14.0	1.52
	65	18.3	8.9	9.8	10.7	11.7	12.6	1.58
	67	19.0	7.9	8.8	9.8	10.7	11.6	1.61
	71	20.4	5.9	6.9	7.7	8.7	9.6	1.68
95	61	16.4	10.6	11.5	12.4	13.2	14.0	1.65
	65	17.7	8.7	9.6	10.6	11.5	12.4	1.72
	67	18.4	7.7	8.7	9.6	10.5	11.4	1.75
	71	19.8	5.8	6.7	7.6	8.5	9.5	1.82
105	61	15.8	10.2	11.1	12.0	12.7	13.4	1.80
	65	17.0	8.4	9.3	10.2	11.1	12.0	1.87
	67	17.7	7.4	8.3	9.2	10.1	11.0	1.90
	71	19.0	6.3	6.4	7.2	8.2	9.1	1.98
115	61	15.1	9.9	10.8	11.6	12.4	13.0	1.94
	65	16.3	8.1	9.0	9.9	10.8	11.7	2.02
	67	16.9	7.1	8.0	8.9	9.8	10.7	2.05
	71	18.2	5.2	6.0	6.9	7.9	8.8	2.13

\* Dry coil condition (Gross Capacity = Sensible Capacity)  
Gross Capacity and Comp. kW are valid only for Wet Coil

Performance at the Rating Conditions of 80/67 & 95 °F  
 GROSS CAPACITY: 18.4 MBH  
 AIRFLOW: 450 CFM  
 SYSTEM POWER: 1958 WATTS  
 NOM. SYSTEM AMPS: 8.4 AMPS  
 All temperature in Degree F



# System Performance Data

## Cooling

### English Units

**TTK524PB WITH MCD524DB  
AT 800 CFM  
GROSS CAPACITY IN BTU/H x 1000**

OUTDOOR D.B.	I.D. W.B.	GROSS CAP.	SENS. CAP. AT ENTERING D.B. TEMP.					COMPR. KW
			72	74	76	78	80	
85	61	22.6	14.7	16.0	17.2	18.4	19.1	2.03
	65	24.4	12.2	13.5	14.7	16.0	17.2	2.12
	67	25.4	10.9	12.1	13.4	14.6	15.9	2.16
	71	27.2	8.1	9.4	10.6	11.9	13.1	2.24
95	61	22.0	14.5	15.7	17.0	18.0	19.1	2.20
	65	23.7	11.9	13.2	14.5	15.7	16.9	2.29
	67	24.6	10.6	11.9	13.1	14.4	15.6	2.34
	71	26.4	7.9	9.1	10.4	11.6	12.9	2.43
105	61	21.1	14.0	15.2	16.4	17.4	18.4	2.40
	65	22.8	11.5	12.7	13.9	15.2	16.4	2.49
	67	23.7	10.1	11.3	12.6	13.8	15.1	2.54
	71	25.4	8.7	8.7	9.9	11.2	12.4	2.64
115	61	20.2	13.6	14.8	15.9	16.9	17.8	2.60
	65	21.8	11.0	12.3	13.5	14.8	16.0	2.70
	67	22.6	9.7	11.0	12.2	13.4	14.7	2.75
	71	24.3	7.1	8.3	9.5	10.8	12.0	2.85

\* Dry coil condition (Gross Capacity = Sensible Capacity)  
Gross Capacity and Comp. kW are valid only for Wet Coil

Performance at the Rating Conditions of 80/67 & 95 °F  
 GROSS CAPACITY: 24.6 MBH  
 AIRFLOW: 600 CFM  
 SYSTEM POWER: 2638 WATTS  
 NOM. SYSTEM AMPS: 12.4 AMPS  
 All temperature in Degree F

**TTK530PB WITH MCD530DB  
AT 1000 CFM  
GROSS CAPACITY IN BTU/H x 1000**

OUTDOOR D.B.	I.D. W.B.	GROSS CAP.	SENS. CAP. AT ENTERING D.B. TEMP.					COMPR. KW
			72	74	76	78	80	
85	61	28.1	21.3	23.2	24.9	26.6	27.7	2.74
	65	30.4	17.6	19.5	21.3	23.1	24.9	2.86
	67	31.5	15.7	17.5	19.4	21.1	23.0	2.91
	71	33.9	11.7	13.6	15.4	17.3	19.0	3.03
95	61	27.4	21.0	22.8	24.6	26.1	27.7*	2.98
	65	29.5	17.3	19.1	20.9	22.7	24.5	3.10
	67	30.6	15.3	17.2	19.0	20.8	22.6	3.16
	71	32.9	11.4	13.2	15.1	16.8	18.7	3.28
105	61	26.2	20.2	22.0	23.7	25.2	26.6*	3.25
	65	28.3	16.6	18.4	20.2	22.0	23.8	3.37
	67	29.5	14.7	16.4	18.3	20.0	21.9	3.43
	71	31.6	12.6	12.6	14.4	16.2	18.0	3.57
115	61	25.1	19.7	21.4	23.0	24.5	25.8*	3.51
	65	27.1	16.0	17.8	19.6	21.4	23.2	3.65
	67	28.2	14.0	15.9	17.6	19.5	21.2	3.71
	71	30.3	10.2	12.0	13.8	15.6	17.4	3.84

\* Dry coil condition (Gross Capacity = Sensible Capacity)  
Gross Capacity and Comp. kW are valid only for Wet Coil

Performance at the Rating Conditions of 80/67 & 95 °F  
 GROSS CAPACITY: 30.6 MBH  
 AIRFLOW: 750 CFM  
 SYSTEM POWER: 3540 WATTS  
 NOM. SYSTEM AMPS: 16.6 AMPS  
 All temperature in Degree F



# System Performance Data

## Cooling

### English Units

**TTK536KB WITH MCD536DB  
AT 1200 CFM  
GROSS CAPACITY IN BTU/H x 1000**

OUTDOOR D.B.	I.D. W.B.	GROSS CAP.	SENS. CAP. AT ENTERING D.B. TEMP.					COMPR. KW
			72	74	76	78	80	
85	61	33.7	23.5	25.5	27.5	29.4	30.5	3.17
	65	36.3	19.4	21.5	23.4	25.5	27.4	3.30
	67	37.7	17.3	19.3	21.3	23.3	25.3	3.36
	71	40.5	12.9	15.0	16.9	19.0	21.0	3.50
95	61	32.7	23.2	25.1	27.1	28.8	30.5	3.44
	65	35.3	19.1	21.0	23.1	25.0	27.0	3.58
	67	36.6	16.9	18.9	20.9	22.9	24.9	3.65
	71	39.3	12.6	14.6	16.6	18.5	20.6	3.79
105	61	31.4	22.3	24.3	26.2	27.8	29.4	3.75
	65	33.9	18.3	20.2	22.3	24.2	26.2	3.89
	67	35.2	16.2	18.1	20.1	22.1	24.1	3.96
	71	37.7	13.8	13.9	15.8	17.9	19.8	4.12
115	61	30.0	21.7	23.6	25.4	27.0	28.4	4.06
	65	32.4	17.6	19.6	21.6	23.6	25.5	4.21
	67	33.7	15.5	17.6	19.4	21.5	23.4	4.29
	71	36.2	11.3	13.2	15.2	17.2	19.1	4.44

\* Dry coil condition (Gross Capacity = Sensible Capacity)  
Gross Capacity and Comp. kW are valid only for Wet Coil

Performance at the Rating Conditions of 80/67 & 95 °F  
 GROSS CAPACITY: 36.6 MBH  
 AIRFLOW: 900 CFM  
 SYSTEM POWER: 4100 WATTS  
 NOM. SYSTEM AMPS: 20.4 AMPS  
 All temperature in Degree F

**TTK536KD WITH MCD536DB  
AT 1200 CFM  
GROSS CAPACITY IN BTU/H x 1000**

OUTDOOR D.B.	I.D. W.B.	GROSS CAP.	SENS. CAP. AT ENTERING D.B. TEMP.					COMPR. KW
			72	74	76	78	80	
85	61	34.1	23.8	25.9	27.8	29.7	30.9	3.05
	65	36.8	19.7	21.7	23.7	25.8	27.8	3.17
	67	38.3	17.5	19.6	21.6	23.6	25.6	3.23
	71	41.1	13.1	15.2	17.1	19.2	21.2	3.37
95	61	33.2	23.4	25.4	27.5	29.1	30.8	3.31
	65	35.8	19.3	21.3	23.3	25.3	27.4	3.44
	67	37.1	17.1	19.2	21.2	23.2	25.2	3.51
	71	39.9	12.8	14.7	16.8	18.8	20.9	3.65
105	61	31.8	22.6	24.6	26.5	28.1	29.7	3.60
	65	34.4	18.5	20.5	22.5	24.5	26.5	3.74
	67	35.7	16.4	18.3	20.4	22.3	24.4	3.81
	71	38.3	14.0	14.1	16.0	18.1	20.1	3.96
115	61	30.4	21.9	23.9	25.7	27.3	28.7	3.90
	65	32.9	17.8	19.9	21.8	23.9	25.8	4.05
	67	34.1	15.7	17.8	19.7	21.7	23.7	4.12
	71	36.7	11.4	13.4	15.3	17.4	19.4	4.27

\* Dry coil condition (Gross Capacity = Sensible Capacity)  
Gross Capacity and Comp. kW are valid only for Wet Coil

Performance at the Rating Conditions of 80/67 & 95 °F  
 GROSS CAPACITY: 37.1 MBH  
 AIRFLOW: 900 CFM  
 SYSTEM POWER: 3960 WATTS  
 NOM. SYSTEM AMPS: 8.4 AMPS  
 All temperature in Degree F





# System Performance Data

## Cooling

English Units

### TTK042KD WITH MCD048DB AT 1400 CFM GROSS CAPACITY IN BTU/H x 1000

OUTDOOR D.B.	I.D. W.B.	GROSS CAP.	SENS. CAP. AT ENTERING D.B. TEMP.					COMPR. KW
			72	74	76	78	80	
85	61	39.6	29.2	31.8	34.2	36.6	38.0	3.76
	65	42.8	24.2	26.7	29.2	31.7	34.1	3.91
	67	44.4	21.6	24.1	26.6	29.0	31.5	3.99
	71	47.7	16.1	18.7	21.1	23.7	26.1	4.15
95	61	38.5	28.8	31.2	33.8	35.9	37.9	4.08
	65	41.5	23.7	26.2	28.7	31.1	33.7	4.24
	67	43.1	21.0	23.6	26.0	28.5	31.0	4.33
	71	46.3	15.7	18.1	20.7	23.1	25.7	4.50
105	61	36.9	27.7	30.2	32.6	34.6	36.5	4.45
	65	39.9	22.8	25.2	27.7	30.1	32.6	4.62
	67	41.5	20.1	22.5	25.1	27.5	30.0	4.70
	71	44.5	17.2	17.3	19.7	22.2	24.7	4.89
115	61	35.4	27.0	29.4	31.6	33.6	35.3	4.81
	65	38.2	21.9	24.4	26.8	29.3	31.8	5.00
	67	39.7	19.3	21.9	24.2	26.7	29.1	5.08
	71	42.6	14.0	16.4	18.9	21.4	23.8	5.27

\* Dry coil condition (Gross Capacity = Sensible Capacity)  
Gross Capacity and Comp. kW are valid only for Wet Coil

Performance at the Rating Conditions of 80/67 & 95 °F  
 GROSS CAPACITY: 43.1 MBH  
 AIRFLOW: 1600 CFM  
 SYSTEM POWER: 5140 WATTS  
 NOM. SYSTEM AMPS: 11.3 AMPS  
 All temperature in Degree F

### TTK048KD WITH MCD048DB AT 1600 CFM GROSS CAPACITY IN BTU/H x 1000

OUTDOOR D.B.	I.D. W.B.	GROSS CAP.	SENS. CAP. AT ENTERING D.B. TEMP.					COMPR. KW
			72	74	76	78	80	
85	61	46.2	37.3	40.6	43.7	46.7*	48.5*	4.38
	65	49.8	30.9	34.2	37.3	40.5	43.6	4.57
	67	51.8	27.5	30.7	34.0	37.1	40.3	4.65
	71	55.6	20.6	23.8	26.9	30.2	33.3	4.84
95	61	44.9	36.8	39.9	43.1	45.8*	48.5*	4.76
	65	48.4	30.3	33.4	36.7	39.8	43.0	4.95
	67	50.2	26.8	30.1	33.3	36.4	39.6	5.05
	71	54.0	20.1	23.1	26.4	29.5	32.8	5.25
105	61	43.0	35.4	38.6	41.6	44.2*	46.7*	5.19
	65	46.5	29.1	32.2	35.4	38.5	41.7	5.38
	67	48.3	25.7	28.8	32.0	35.1	38.3	5.48
	71	51.8	22.0	22.1	25.2	28.4	31.5	5.70
115	61	41.2	34.5	37.5	40.3	42.9*	45.2*	5.61
	65	44.5	28.0	31.2	34.3	37.5	40.6	5.83
	67	46.2	24.6	27.9	30.9	34.1	37.2	5.93
	71	49.6	17.9	21.0	24.1	27.3	30.4	6.14

\* Dry coil condition (Gross Capacity = Sensible Capacity)  
Gross Capacity and Comp. kW are valid only for Wet Coil

Performance at the Rating Conditions of 80/67 & 95 °F  
 GROSS CAPACITY: 50.2 MBH  
 AIRFLOW: 1600 CFM  
 SYSTEM POWER: 5850 WATTS  
 NOM. SYSTEM AMPS: 12.6 AMPS  
 All temperature in Degree F



# System Performance Data

## Cooling

English Units

**TTK060KD WITH MCD060DB  
AT 2000 CFM  
GROSS CAPACITY IN BTU/H x 1000**

OUTDOOR D.B.	I.D. W.B.	GROSS CAP.	SENS. CAP. AT ENTERING D.B. TEMP.					COMPR. KW
			72	74	76	78	80	
85	61	55.4	45.4	49.4	53.1	56.7*	58.9*	5.56
	65	59.8	37.6	41.5	45.3	49.2	53.0	5.79
	67	62.1	33.5	37.3	41.2	45.0	48.9	5.90
	71	66.7	25.0	29.0	32.7	36.7	40.5	6.15
95	61	53.8	44.7	48.5	52.4	55.6*	58.9*	6.04
	65	58.0	36.8	40.6	44.6	48.3	52.2	6.28
	67	60.2	32.6	36.6	40.4	44.3	48.1	6.41
	71	64.7	24.4	28.1	32.1	35.8	39.9	6.66
105	61	51.6	43.0	46.9	50.5	53.6*	56.7*	6.58
	65	55.8	35.3	39.1	43.0	46.8	50.7	6.83
	67	58.0	31.2	35.0	38.9	42.6	46.6	6.96
	71	62.1	26.7	26.8	30.6	34.5	38.3	7.24
115	61	49.4	41.8	45.6	49.0	52.2*	54.8*	7.12
	65	53.3	34.0	37.9	41.6	45.5	49.3	7.40
	67	55.4	29.9	33.9	37.5	41.5	45.2	7.53
	71	59.5	21.7	25.5	29.3	33.2	37.0	7.79

\* Dry coil condition (Gross Capacity = Sensible Capacity)  
Gross Capacity and Comp. kW are valid only for Wet Coil

Performance at the Rating Conditions of 80/67 & 95 °F  
 GROSS CAPACITY: 60.2 MBH  
 AIRFLOW: 2000 CFM  
 SYSTEM POWER: 7315 WATTS  
 NOM. SYSTEM AMPS: 15.4 AMPS  
 All temperature in Degree F



# System Performance Data

## Cooling

### English Units

#### TTK512L1 WITH MCD512D1 AT 400 CFM GROSS CAPACITY IN BTU/H x 1000

OUTDOOR D.B.	I.D. W.B.	GROSS CAP.	SENS. CAP. AT ENTERING D.B. TEMP.					COMPR. KW
			72	74	76	78	80	
85	61	11.8	8.8	9.5	10.3	11.0	11.4	1.17
	65	12.7	7.3	8.0	8.8	9.5	10.2	1.22
	67	13.2	6.5	7.2	8.0	8.7	9.5	1.24
	71	14.2	4.8	5.6	6.3	7.1	7.8	1.29
95	61	11.4	8.7	9.4	10.1	10.8	11.4	1.27
	65	12.3	7.1	7.8	8.6	9.3	10.1	1.32
	67	12.8	6.3	7.1	7.8	8.6	9.3	1.35
	71	13.8	4.7	5.4	6.2	6.9	7.7	1.40
105	61	11.0	8.3	9.1	9.8	10.4	11.0	1.39
	65	11.9	6.8	7.6	8.3	9.0	9.8	1.44
	67	12.3	6.0	6.8	7.5	8.2	9.0	1.47
	71	13.2	5.2	5.2	5.9	6.7	7.4	1.52
115	61	10.5	8.1	8.8	9.5	10.1	10.6*	1.50
	65	11.3	6.6	7.3	8.1	8.8	9.5	1.56
	67	11.8	5.8	6.6	7.3	8.0	8.7	1.58
	71	12.7	4.2	4.9	5.7	6.4	7.2	1.64

\* Dry coil condition (Gross Capacity = Sensible Capacity)  
Gross Capacity and Comp. kW are valid only for Wet Coil

Performance at the Rating Conditions of 80/67 & 95 °F  
 GROSS CAPACITY: 12.8 MBH  
 AIRFLOW: 300 CFM  
 SYSTEM POWER: 1540 WATTS  
 NOM. SYSTEM AMPS: 7.0 AMPS  
 All temperature in Degree F

#### TTK518P1 WITH MCD518D1 AT 600 CFM GROSS CAPACITY IN BTU/H x 1000

OUTDOOR D.B.	I.D. W.B.	GROSS CAP.	SENS. CAP. AT ENTERING D.B. TEMP.					COMPR. KW
			72	74	76	78	80	
85	61	17.2	10.9	11.9	12.8	13.7	14.2	1.63
	65	18.6	9.1	10.0	10.9	11.9	12.8	1.70
	67	19.3	8.1	9.0	9.9	10.9	11.8	1.73
	71	20.7	6.0	7.0	7.9	8.9	9.8	1.80
95	61	16.7	10.8	11.7	12.6	13.4	14.2	1.77
	65	18.0	8.9	9.8	10.7	11.7	12.6	1.84
	67	18.7	7.9	8.8	9.7	10.7	11.6	1.88
	71	20.1	5.9	6.8	7.7	8.6	9.6	1.95
105	61	16.0	10.4	11.3	12.2	12.9	13.7	1.93
	65	17.3	8.5	9.4	10.4	11.3	12.2	2.00
	67	18.0	7.5	8.4	9.4	10.3	11.2	2.04
	71	19.3	6.4	6.5	7.4	8.3	9.2	2.12
115	61	15.3	10.1	11.0	11.8	12.6	13.2	2.09
	65	16.6	8.2	9.1	10.0	11.0	11.9	2.17
	67	17.2	7.2	8.2	9.1	10.0	10.9	2.21
	71	18.5	5.2	6.1	7.1	8.0	8.9	2.29

\* Dry coil condition (Gross Capacity = Sensible Capacity)  
Gross Capacity and Comp. kW are valid only for Wet Coil

Performance at the Rating Conditions of 80/67 & 95 °F  
 GROSS CAPACITY: 18.7 MBH  
 AIRFLOW: 450 CFM  
 SYSTEM POWER: 2135 WATTS  
 NOM. SYSTEM AMPS: 9.9 AMPS  
 All temperature in Degree F



# System Performance Data

## Cooling

English Units

### TTK524P1 WITH MCD524D1 AT 800 CFM GROSS CAPACITY IN BTU/H x 1000

OUTDOOR D.B.	I.D. W.B.	GROSS CAP.	SENS. CAP. AT ENTERING D.B. TEMP.					COMPR. KW
			72	74	76	78	80	
85	61	22.3	14.4	15.7	16.9	18.0	18.7	1.99
	65	24.0	11.9	13.2	14.4	15.7	16.9	2.07
	67	25.0	10.6	11.9	13.1	14.3	15.6	2.11
	71	26.8	7.9	9.2	10.4	11.7	12.9	2.20
95	61	21.6	14.2	15.4	16.7	17.7	18.7	2.16
	65	23.3	11.7	12.9	14.2	15.4	16.6	2.24
	67	24.2	10.4	11.6	12.9	14.1	15.3	2.29
	71	26.0	7.7	8.9	10.2	11.4	12.7	2.38
105	61	20.7	13.7	14.9	16.1	17.1	18.0	2.35
	65	22.4	11.2	12.4	13.7	14.9	16.1	2.44
	67	23.3	9.9	11.1	12.4	13.6	14.8	2.49
	71	25.0	8.5	8.5	9.7	11.0	12.2	2.59
115	61	19.9	13.3	14.5	15.6	16.6	17.4	2.54
	65	21.4	10.8	12.1	13.2	14.5	15.7	2.64
	67	22.3	9.5	10.8	11.9	13.2	14.4	2.69
	71	23.9	6.9	8.1	9.3	10.6	11.8	2.78

\* Dry coil condition (Gross Capacity = Sensible Capacity)  
Gross Capacity and Comp. kW are valid only for Wet Coil

Performance at the Rating Conditions of 80/67 & 95 °F  
 GROSS CAPACITY: 24.2 MBH  
 AIRFLOW: 600 CFM  
 SYSTEM POWER: 2625 WATTS  
 NOM. SYSTEM AMPS: 12.4 AMPS  
 All temperature in Degree F

### TTK530P1 WITH MCD530D1 AT 1000 CFM GROSS CAPACITY IN BTU/H x 1000

OUTDOOR D.B.	I.D. W.B.	GROSS CAP.	SENS. CAP. AT ENTERING D.B. TEMP.					COMPR. KW
			72	74	76	78	80	
85	61	29.2	20.2	22.0	23.6	25.2	26.2	2.81
	65	31.6	16.7	18.5	20.2	21.9	23.6	2.93
	67	32.8	14.9	16.6	18.3	20.0	21.8	2.98
	71	35.2	11.1	12.9	14.5	16.3	18.0	3.11
95	61	28.4	19.9	21.6	23.3	24.8	26.2	3.05
	65	30.7	16.4	18.1	19.8	21.5	23.2	3.18
	67	31.8	14.5	16.3	18.0	19.7	21.4	3.24
	71	34.2	10.8	12.5	14.3	15.9	17.7	3.37
105	61	27.3	19.2	20.9	22.5	23.9	25.2	3.33
	65	29.5	15.7	17.4	19.1	20.8	22.5	3.45
	67	30.6	13.9	15.6	17.3	19.0	20.7	3.52
	71	32.8	11.9	11.9	13.6	15.4	17.0	3.66
115	61	26.1	18.6	20.3	21.8	23.2	24.4	3.60
	65	28.2	15.1	16.9	18.5	20.3	21.9	3.74
	67	29.3	13.3	15.1	16.7	18.4	20.1	3.80
	71	31.5	9.7	11.3	13.0	14.8	16.5	3.94

\* Dry coil condition (Gross Capacity = Sensible Capacity)  
Gross Capacity and Comp. kW are valid only for Wet Coil  
 Performance at the Rating Conditions of 80/67 & 95 °F  
 GROSS CAPACITY: 31.8 MBH  
 AIRFLOW: 750 CFM  
 SYSTEM POWER: 3730 WATTS  
 NOM. SYSTEM AMPS: 17.9 AMPS  
 All temperature in Degree F



# System Performance Data

## Cooling

English Units

### TTK536K1 WITH MCD536D1 AT 1200 CFM GROSS CAPACITY IN BTU/H x 1000

OUTDOOR D.B.	I.D. W.B.	GROSS CAP.	SENS. CAP. AT ENTERING D.B. TEMP.					COMPR. KW
			72	74	76	78	80	
85	61	33.6	21.5	23.4	25.2	26.9	27.9	2.96
	65	36.2	17.8	19.7	21.5	23.3	25.1	3.08
	67	37.6	15.9	17.7	19.5	21.3	23.2	3.14
	71	40.4	11.8	13.7	15.5	17.4	19.2	3.27
95	61	32.6	21.2	23.0	24.8	26.4	27.9	3.21
	65	35.2	17.5	19.2	21.1	22.9	24.8	3.34
	67	36.5	15.5	17.3	19.2	21.0	22.8	3.41
	71	39.2	11.5	13.3	15.2	17.0	18.9	3.54
105	61	31.3	20.4	22.2	24.0	25.4	26.9	3.50
	65	33.8	16.7	18.5	20.4	22.2	24.0	3.64
	67	35.1	14.8	16.6	18.4	20.2	22.1	3.70
	71	37.6	12.7	12.7	14.5	16.4	18.1	3.85
115	61	30.0	19.8	21.6	23.2	24.7	26.0	3.79
	65	32.3	16.1	18.0	19.7	21.6	23.4	3.94
	67	33.6	14.2	16.1	17.8	19.7	21.4	4.00
	71	36.1	10.3	12.1	13.9	15.7	17.5	4.15

\* Dry coil condition (Gross Capacity = Sensible Capacity)  
Gross Capacity and Comp. kW are valid only for Wet Coil

Performance at the Rating Conditions of 80/67 & 95 °F  
 GROSS CAPACITY: 36.5 MBH  
 AIRFLOW: 900 CFM  
 SYSTEM POWER: 3930 WATTS  
 NOM. SYSTEM AMPS: 18.2 AMPS  
 All temperature in Degree F

### TTK536K4 WITH MCD536D1 AT 1200 CFM GROSS CAPACITY IN BTU/H x 1000

OUTDOOR D.B.	I.D. W.B.	GROSS CAP.	SENS. CAP. AT ENTERING D.B. TEMP.					COMPR. KW
			72	74	76	78	80	
85	61	33.6	21.5	23.4	25.2	26.9	27.9	2.95
	65	36.2	17.8	19.7	21.5	23.3	25.1	3.07
	67	37.6	15.9	17.7	19.5	21.3	23.2	3.13
	71	40.4	11.8	13.7	15.5	17.4	19.2	3.26
95	61	32.6	21.2	23.0	24.8	26.4	27.9	3.20
	65	35.2	17.5	19.2	21.1	22.9	24.8	3.33
	67	36.5	15.5	17.3	19.2	21.0	22.8	3.40
	71	39.2	11.5	13.3	15.2	17.0	18.9	3.53
105	61	31.3	20.4	22.2	24.0	25.4	26.9	3.49
	65	33.8	16.7	18.5	20.4	22.2	24.0	3.62
	67	35.1	14.8	16.6	18.4	20.2	22.1	3.69
	71	37.6	12.7	12.7	14.5	16.4	18.1	3.84
115	61	30.0	19.8	21.6	23.2	24.7	26.0	3.78
	65	32.3	16.1	18.0	19.7	21.6	23.4	3.92
	67	33.6	14.2	16.1	17.8	19.7	21.4	3.99
	71	36.1	10.3	12.1	13.9	15.7	17.5	4.13

\* Dry coil condition (Gross Capacity = Sensible Capacity)  
Gross Capacity and Comp. kW are valid only for Wet Coil

Performance at the Rating Conditions of 80/67 & 95 °F  
 GROSS CAPACITY: 36.5 MBH  
 AIRFLOW: 900 CFM  
 SYSTEM POWER: 3895 WATTS  
 NOM. SYSTEM AMPS: 7.8 AMPS  
 All temperature in Degree F



# System Performance Data

## Cooling

### English Units

#### TTK042K4 WITH MCD048D1 AT 1400 CFM GROSS CAPACITY IN BTU/H x 1000

OUTDOOR D.B.	I.D. W.B.	GROSS CAP.	SENS. CAP. AT ENTERING D.B. TEMP.					COMPR. KW
			72	74	76	78	80	
85	61	39.6	35.0	38.1	40.9*	43.7*	45.4*	4.24
	65	42.8	29.0	32.0	34.9	38.0	40.9	4.42
	67	44.4	25.8	28.8	31.8	34.7	37.7	4.50
	71	47.7	19.3	22.3	25.2	28.3	31.2	4.69
95	61	38.5	34.5	37.4	40.4*	42.9*	45.4*	4.61
	65	41.5	28.4	31.3	34.4	37.3	40.3	4.79
	67	43.1	25.2	28.2	31.2	34.1	37.1	4.89
	71	46.3	18.8	21.7	24.7	27.6	30.8	5.08
105	61	36.9	33.2	36.2	39.0*	41.4*	43.7*	5.02
	65	39.9	27.2	30.2	33.2	36.1	39.1	5.21
	67	41.5	24.1	27.0	30.0	32.9	35.9	5.31
	71	44.5	20.6	20.7	23.6	26.6	29.5	5.52
115	61	35.4	32.3	35.2	37.8*	40.2*	42.3*	5.43
	65	38.2	26.2	29.2	32.1	35.1	38.0	5.64
	67	39.7	23.1	26.2	28.9	32.0	34.9	5.74
	71	42.6	16.8	19.7	22.6	25.6	28.5	5.95

\* Dry coil condition (Gross Capacity = Sensible Capacity)  
Gross Capacity and Comp. kW are valid only for Wet Coil

Performance at the Rating Conditions of 80/67 & 95 °F  
 GROSS CAPACITY: 43.1 MBH  
 AIRFLOW: 1400 CFM  
 SYSTEM POWER: 5560 WATTS  
 NOM. SYSTEM AMPS: 11.7 AMPS  
 All temperature in Degree F

#### TTK048K4 WITH MCD048D1 AT 1600 CFM GROSS CAPACITY IN BTU/H x 1000

OUTDOOR D.B.	I.D. W.B.	GROSS CAP.	SENS. CAP. AT ENTERING D.B. TEMP.					COMPR. KW
			72	74	76	78	80	
85	61	45.1	38.1	41.5	44.6	47.6*	49.5*	4.57
	65	48.6	31.5	34.8	38.0	41.3	44.5	4.76
	67	50.5	28.1	31.3	34.6	37.8	41.1	4.84
	71	54.3	21.0	24.3	27.5	30.9	34.0	5.04
95	61	43.8	37.6	40.7	44.0*	46.7*	49.4*	4.95
	65	47.2	30.9	34.1	37.4	40.6	43.9	5.15
	67	49.0	27.4	30.7	33.9	37.2	40.4	5.26
	71	52.7	20.5	23.6	26.9	30.1	33.5	5.47
105	61	42.0	36.2	39.4	42.4*	45.1*	47.6*	5.40
	65	45.4	29.7	32.8	36.1	39.3	42.5	5.61
	67	47.2	26.2	29.4	32.7	35.8	39.1	5.71
	71	50.5	22.4	22.5	25.7	29.0	32.1	5.94
115	61	40.2	35.1	38.3	41.1*	43.8*	46.1*	5.84
	65	43.4	28.6	31.8	35.0	38.2	41.4	6.07
	67	45.1	25.1	28.5	31.5	34.8	38.0	6.18
	71	48.5	18.3	21.4	24.6	27.9	31.1	6.40

\* Dry coil condition (Gross Capacity = Sensible Capacity)  
Gross Capacity and Comp. kW are valid only for Wet Coil

Performance at the Rating Conditions of 80/67 & 95 °F  
 GROSS CAPACITY: 49.0 MBH  
 AIRFLOW: 1600 CFM  
 SYSTEM POWER: 6020 WATTS  
 NOM. SYSTEM AMPS: 12.3 AMPS  
 All temperature in Degree F



# System Performance Data

## Cooling

English Units

**TTK060K4 WITH MCD060D1  
AT 2000 CFM  
GROSS CAPACITY IN BTU/H x 1000**

OUTDOOR D.B.	I.D. W.B.	GROSS CAP.	SENS. CAP. AT ENTERING D.B. TEMP.					COMPR. KW
			72	74	76	78	80	
85	61	55.2	45.7	49.8	53.5	57.2*	59.4*	5.49
	65	59.6	37.9	41.8	45.7	49.6	53.4	5.72
	67	61.9	33.7	37.6	41.6	45.4	49.3	5.83
	71	66.4	25.2	29.2	33.0	37.0	40.8	6.07
95	61	53.6	45.1	48.9	52.8	56.1*	59.4*	5.96
	65	57.8	37.1	40.9	44.9	48.7	52.7	6.20
	67	60.0	32.9	36.9	40.7	44.6	48.5	6.33
	71	64.5	24.6	28.3	32.3	36.1	40.2	6.58
105	61	51.4	43.4	47.3	50.9	54.1*	57.2*	6.50
	65	55.6	35.6	39.4	43.4	47.1	51.1	6.75
	67	57.8	31.5	35.3	39.2	43.0	46.9	6.87
	71	61.9	26.9	27.1	30.8	34.8	38.6	7.15
115	61	49.2	42.2	46.0	49.4*	52.6*	55.3*	7.03
	65	53.2	34.3	38.2	42.0	45.9	49.7	7.30
	67	55.2	30.1	34.2	37.8	41.8	45.6	7.43
	71	59.3	21.9	25.7	29.5	33.5	37.3	7.70

\* Dry coil condition (Gross Capacity = Sensible Capacity)  
Gross Capacity and Comp. kW are valid only for Wet Coil

Performance at the Rating Conditions of 80/67 & 95 °F

GROSS CAPACITY: 60.0 MBH  
 AIRFLOW: 2000 CFM  
 SYSTEM POWER: 7290 WATTS  
 NOM. SYSTEM AMPS: 14.4 AMPS  
 All temperature in Degree F

# MCD Wiring Diagram

**COOLING ONLY**  
**MCD009-012AA5**  
**MCD036EB5**

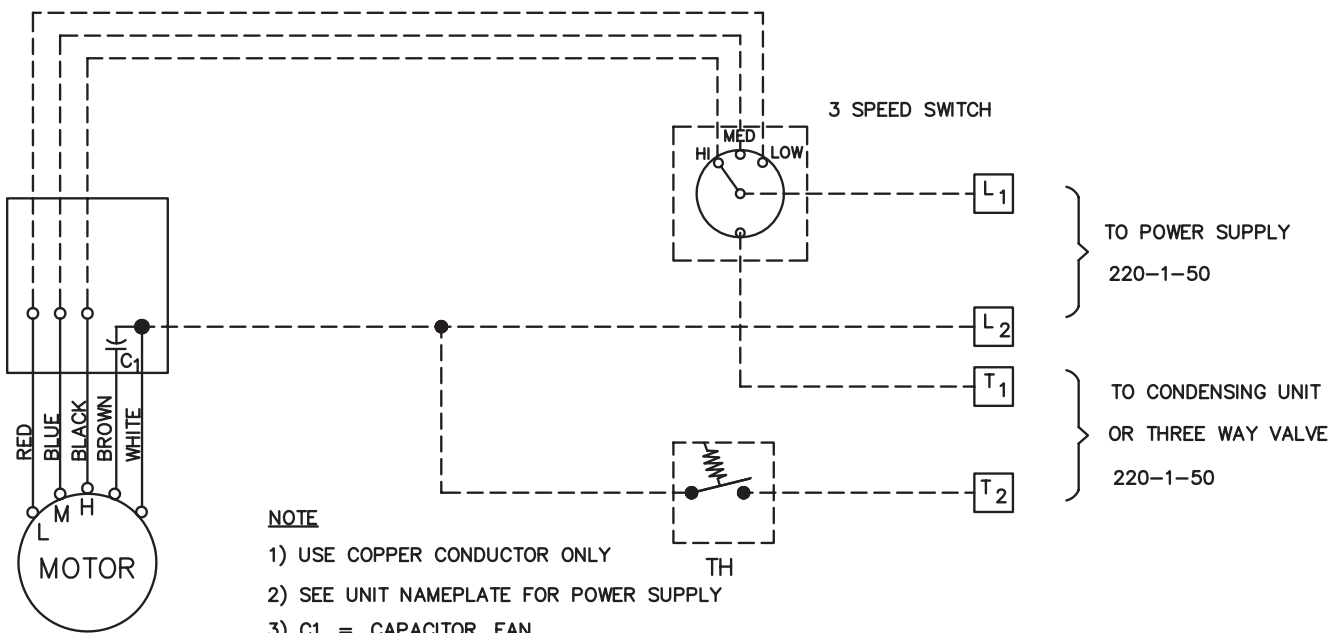

**NOTE**

- 1) USE COPPER CONDUCTOR ONLY
- 2) SEE UNIT NAMEPLATE FOR POWER SUPPLY
- 3) C1 = CAPACITOR, FAN
- 4) J = JUNCTION BOX
- 5) TH = THERMOSTAT
- 6) - - - FIELD WIRING & DEVICES BY OTHER
- 7) ——— FACTORY WIRING & DEVICES BY TRANE
- 8) MODEL MCD 030, 036 AA AND MCD 036 THRU MCD060 BA  
 HAVE TWO MOTORS WIRED PARALLEL



# MCD Wiring Diagram

## COOLING ONLY

**MCD018AA5-MCD024AA5**

**MCD030EB5, MCD042EB5**

**MCD512-536DB / D1**

**MCD048-060DB / D1**

Remove HI-BR wire from TB-1 and replace with EXTRA HI-BLK wire when high speed/cfm is required in the field.

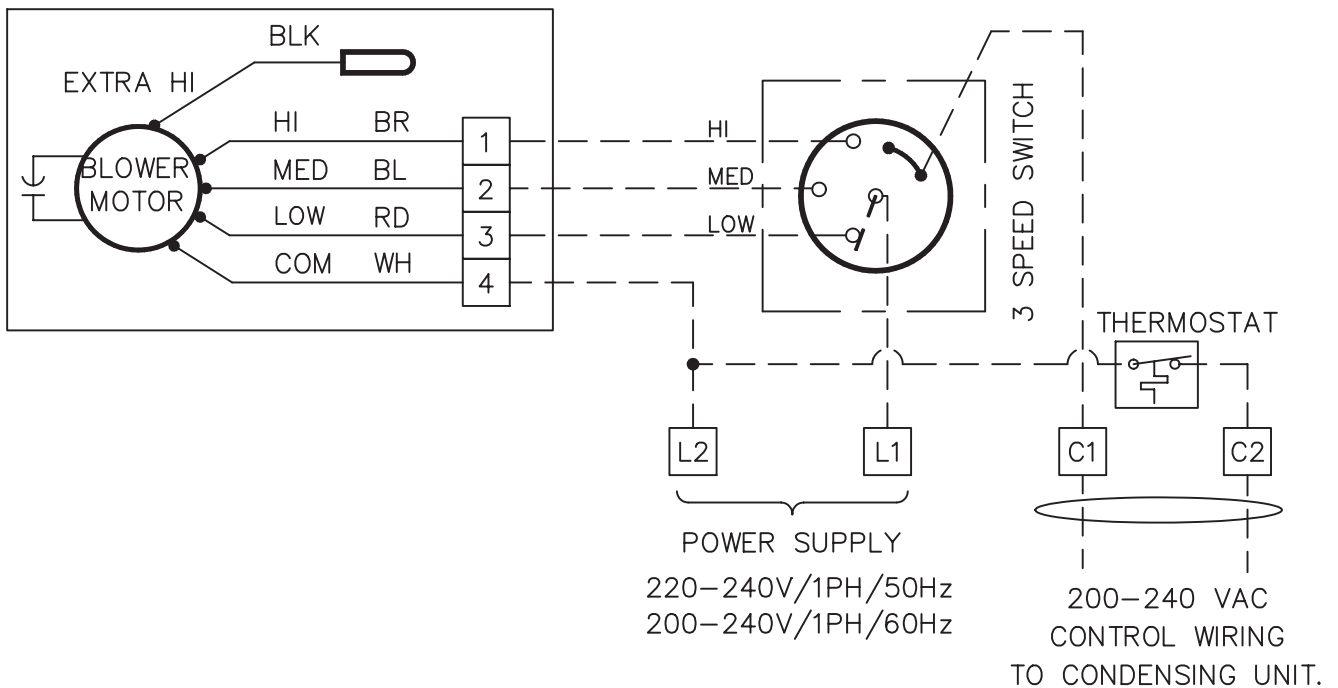

### LEGEND :

----- FIELD WIRING  
 \_\_\_\_\_ FACTORY WIRING

### NOTES :

1. Power wiring and grounding of equipment must comply with local codes.
2. Ensure that power supply agrees with equipment nameplate.
3. Use only copper conductors.

# MCD Wiring Diagram

## COOLING HEATING MCD512-524DB / D1

REMOVE HI-BR WIRE FROM TB-1 AND REPLACE WITH EXTRA HI-BLK WIRE WHEN HI SPEED/CFM IS REQUIRED IN THE FIELD.

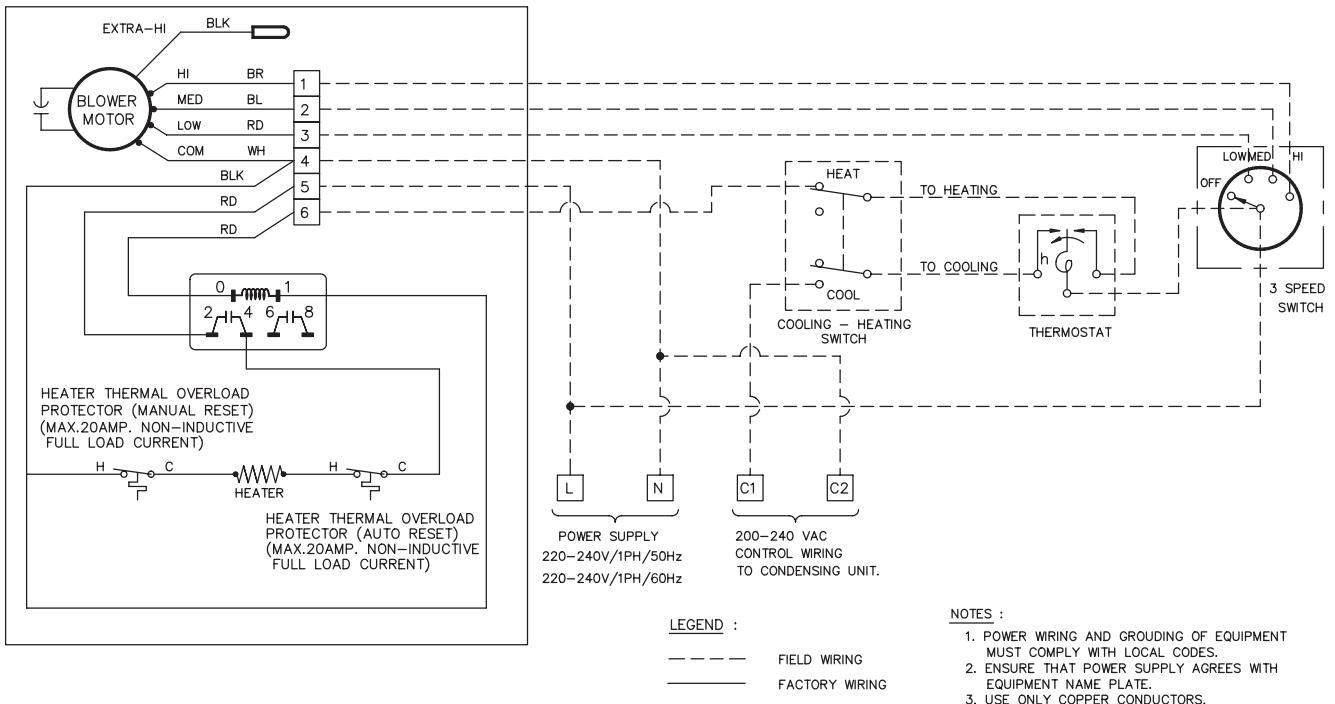

# MCD Wiring Diagram

## COOLING HEATING MCD530-536DB / D1 MCD048-060DB / D1

Remove HI-BR wire FROM TB-1 and replace with EXTRA HI-BLK wire when high speed/cfm is required in the field.

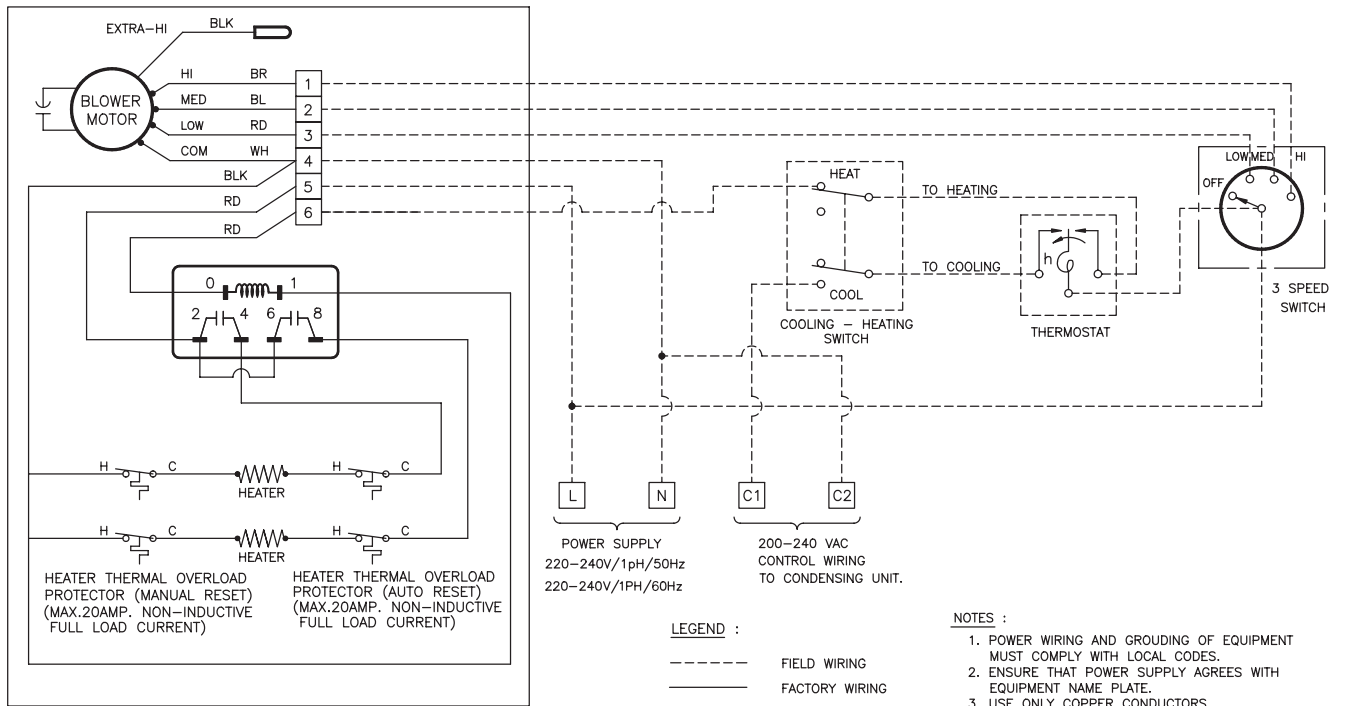

# TTK Wiring Diagram

TTK512LB  
 TTK512-524LB5  
 TTK530-536KB5  
 TTK518-530PB/P1  
 TTK536-060K1  
 TTK536KB

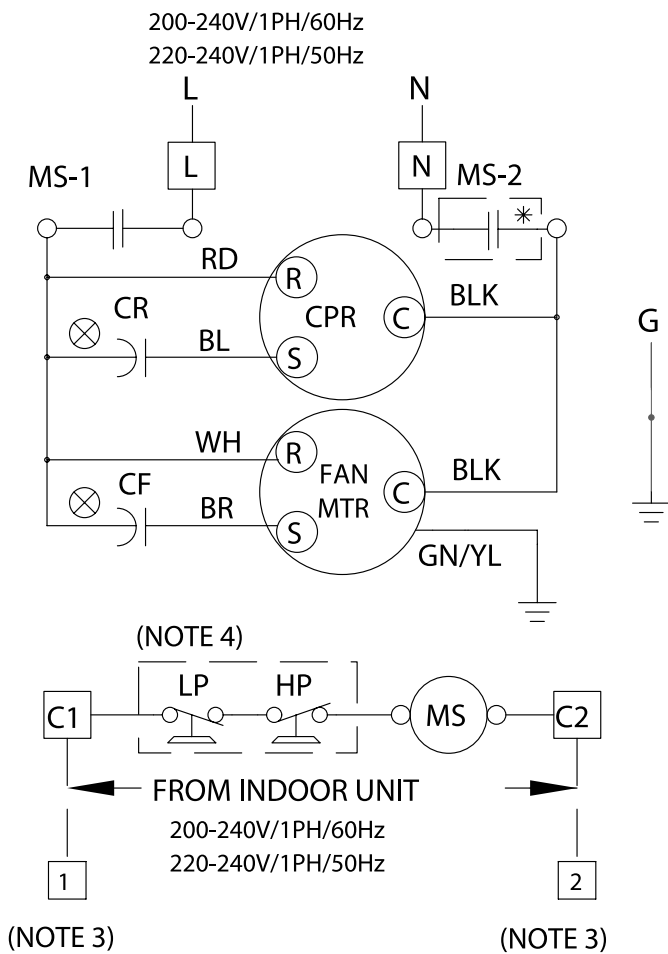

### LEGEND

CPR COMPRESSOR  
 CF FAN CAPACITOR  
 CR COMPRESSOR RUN CAPACITOR  
 FAN MTR FAN MOTOR  
 MS COMPRESSOR MOTOR CONTACTOR

○ TERMINAL  
 • JUNCTION  
 ⊗ IDENTIFIED TERMINAL  
 ⊙ COIL  
 □ [ ] TERMINAL BOARD BY OTHERS  
 □ [ ] TERMINAL BOARD BY FACTORY  
 — FIELD WIRING  
 — FACTORY WIRING  
 || RELAY CONTACT N.O.  
 —(—) CAPACITOR  
 ⊖ LOW PRESSURE SENSOR  
 ⊕ HIGH PRESSURE SENSOR

\* APPLY FOR DOUBLE POLE CONTACTOR ONLY  
 (FOR SINGLE POLE CONTACTOR, CONNECT ELECTRIC LINE FROM COMPRESSOR-C AND FAN MOTOR-C DIRECT TO TERMINAL-N)

### COLOR CODE

BL BLUE  
 BLK BLACK  
 BR BROWN  
 GN GREEN  
 GR GRAY  
 OR ORANGE  
 RD RED  
 WH WHITE  
 YL YELLOW

### NOTES:

1. POWER WIRING AND GROUNDING OF EQUIPMENT MUST COMPLY WITH LOCAL CODES.
2. USE COPPER CONDUCTORS ONLY.
3. TERMINALS AND [1] ARE [2] LOCATED ON INDOOR TERMINAL BOARD OF INDOOR UNITS.
4. HIGH & LOW PRESSURE SENSOR AVAILABLE IN OPTION MODEL.

# TTK Wiring Diagram

TTK536-042KD5  
 TTK536-060KD  
 TTK536-042K4  
 TTK060K3

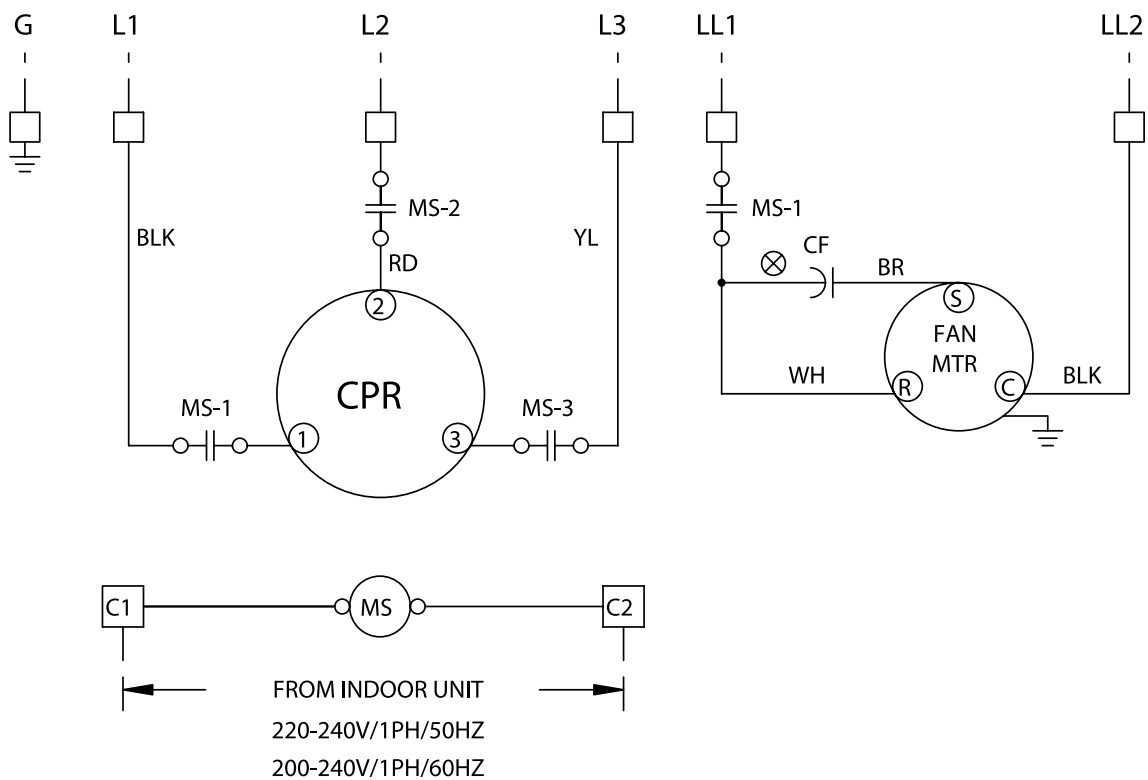

### LEGEND

CPR COMPRESSOR  
 CF FAN CAPACITOR  
 FAN MTR FAN MOTOR  
 MS COMPRESSOR MOTOR CONTACTOR

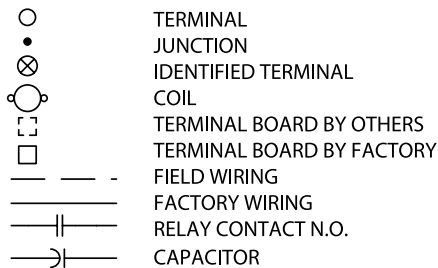

### NOTES:

1. POWER WIRING AND GROUNDING OF EQUIPMENT MUST COMPLY WITH LOCAL CODES.
2. USE COPPER CONDUCTORS ONLY.
3. THREE PHASE CONDENSING UNITS REQUIRE TWO POWER SUPPLY SOURCES AS SHOWN.

### COLOR CODE

BL BLUE  
 BLK BLACK  
 BR BROWN  
 GR GRAY  
 OR ORANGE  
 RD RED  
 WH WHITE  
 YL YELLOW

# TTK Wiring Diagram

## TTK048-060K4

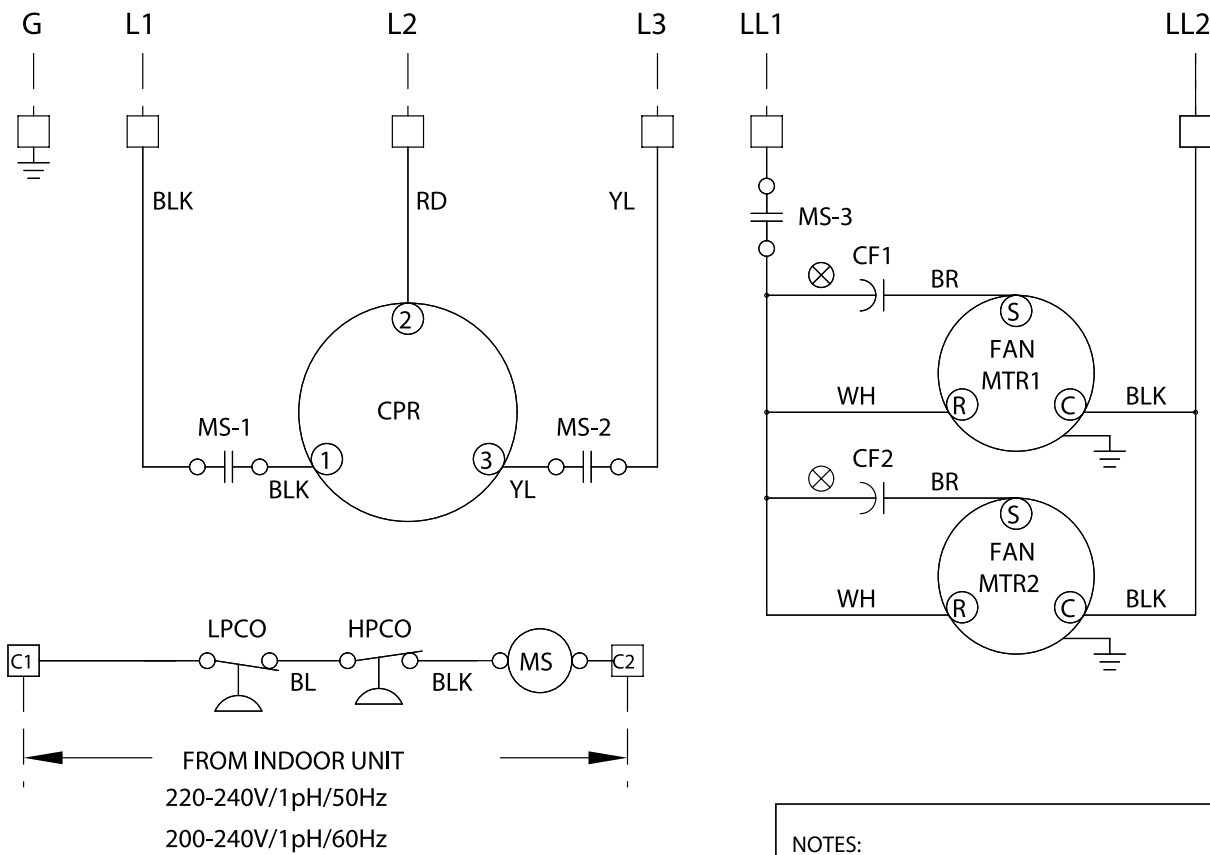

### LEGEND

CPR	COMPRESSOR
CF1, 2	FAN CAPACITOR
FAN MTR1, 2	FAN MOTOR
HPCO	HIGH PRESSURE CUT-OUT
LPCO	LOW PRESSURE CUT-OUT
MS	COMPRESSOR MOTOR CONTACTOR
○	TERMINAL
⊙	JUNCTION
⊗	IDENTIFIED TERMINAL
⊕	COIL
□	TERMINAL BOARD BY OTHERS
□	TERMINAL BOARD BY FACTORY
— — —	FIELD WIRING
— — —	FACTORY WIRING
— — —	RELAY CONTACT N.O.
— — —	CAPACITOR
— — —	PRESSURE SENSING SWITCH

### NOTES:

1. POWER WIRING AND GROUNDING OF EQUIPMENT MUST COMPLY WITH LOCAL CODES.
2. USE COPPER CONDUCTORS ONLY.
3. THREE PHASE CONDENSING UNITS REQUIRE TWO POWER SUPPLY SOURCES AS SHOWN.
4. HIGH & LOW PRESSURE CUT-OUT ARE OPTIONAL ACCESSORIES FOR TTK042KD5.

### COLOR CODE

BL	BLUE
BLK	BLACK
BR	BROWN
GR	GRAY
OR	ORANGE
RD	RED
WH	WHITE
YL	YELLOW

# MCD Dimensional Data

## OUTLINE DIMENSION MCD009-024AA5

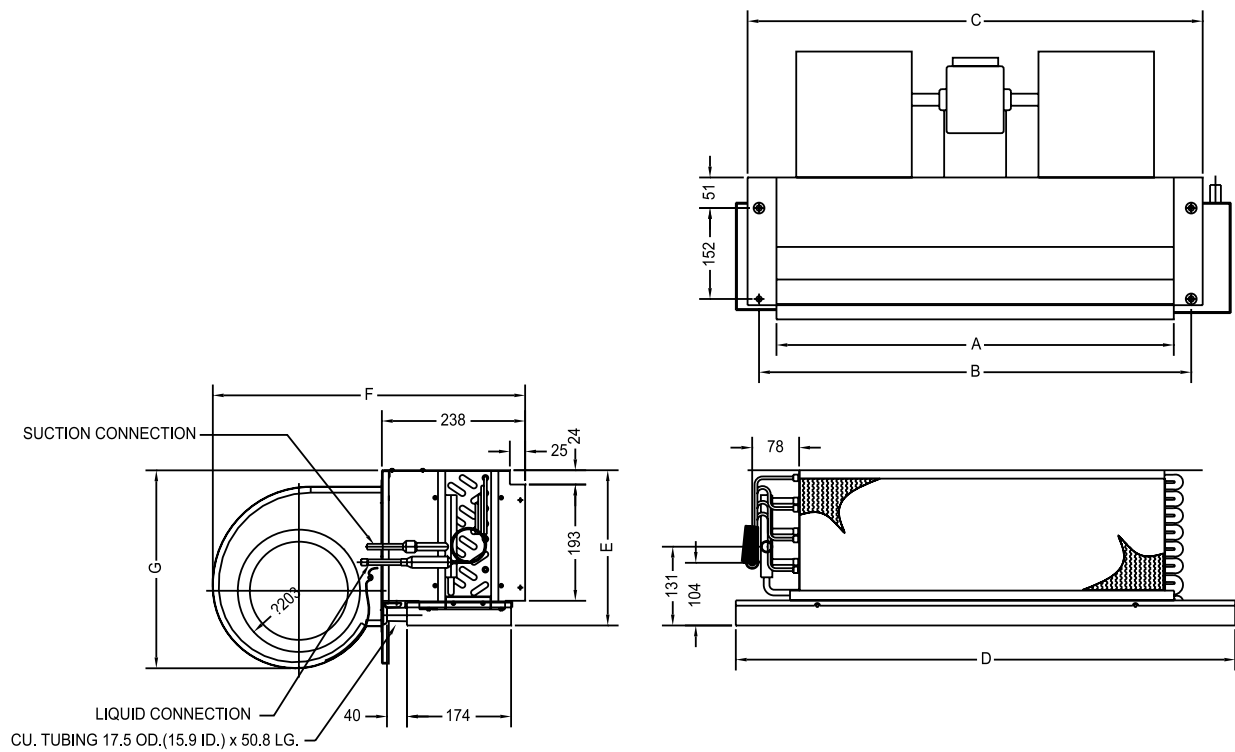





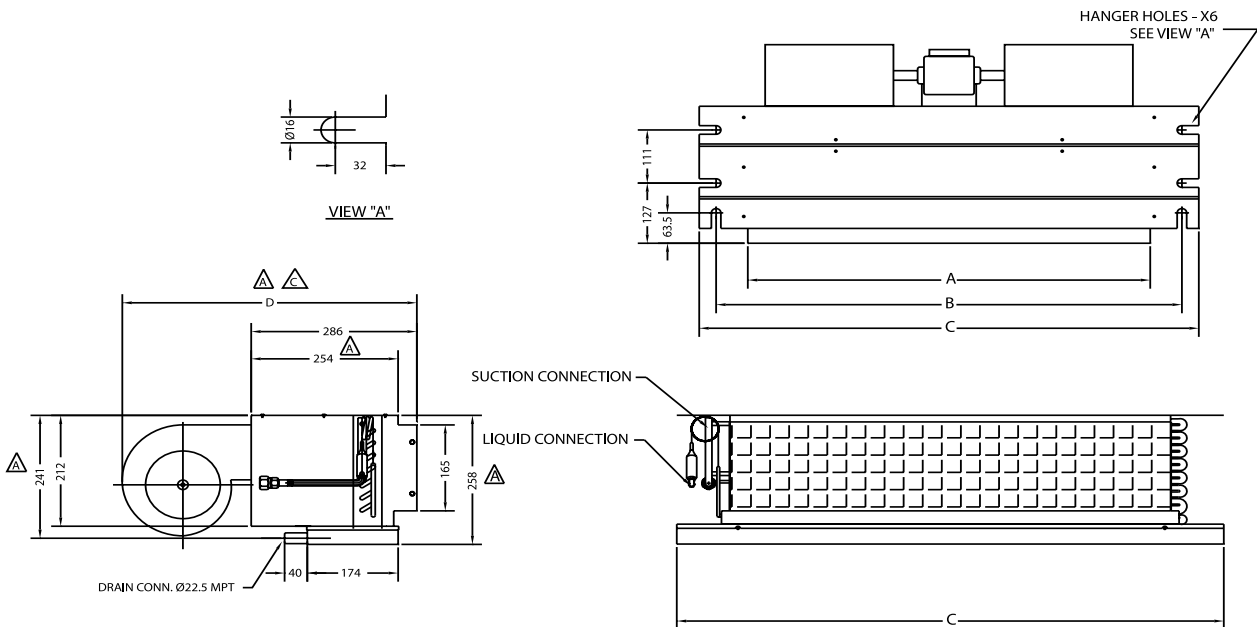

### External Dimensions

Model	All External Dimensions are in inch (mm.)							Refrig Line Conn. Size.		Number Of	
	A	B	C	D	E	F	G	Liquid	Suction	Fan(s)	Motor(s)
MCD009AA5(LH)	31 1/4"(794)	33 1/4"(845)	34 3/4"(883)	37 1/4"(946)	10 1/4"(260)	17 1/2"(445)	8 7/8"(226)	1/4"(6.35)	1/2"(12.7)	2	1
MCD012AA5(LH)	31 1/4"(794)	33 1/4"(845)	34 3/4"(883)	37 1/4"(946)	10 1/4"(260)	17 1/2"(445)	8 7/8"(226)	3/8"(9.53)	5/8"(15.87)	2	1
MCD018AA5(LH)	38 1/4"(972)	40 1/4"(1022)	41 3/4"(1061)	43 1/4"(1098)	10 1/4"(260)	19" (482)	10 5/8"(270)	3/8"(9.53)	5/8"(15.87)	2	1
MCD024AA5(LH)	38 1/4"(972)	40 1/4"(1022)	41 3/4"(1061)	43 1/4"(1098)	10 1/4"(260)	20 1/2"(520)	12 3/4"(325)	3/8"(9.53)	5/8"(15.87)	2	1

# MCD Dimensional Data

## OUTLINE DIMENSION MCD512-536DB/D1



Model	All External Dimensions are in inch (mm.)				Refrig Line Conn. Size.		Number Of	
	A	B	C	D	Liquid	Suction	Fan(s)	Motor(s)
MWD/MCD512DB/D1	30 1/16"(764)	34 3/4"(882)	37 1/4"(946)	19 7/16"(494)	1/4"(6.35)	1/2"(12.7)	2	1
MWD/MCD518DB/D1	30 1/16"(764)	34 3/4"(882)	37 1/4"(946)	19 7/16"(494)	1/4"(6.35)	1/2"(12.7)	2	1
MWD/MCD524DB/D1	30 1/16"(764)	34 3/4"(882)	37 1/4"(946)	20"(509) 	3/8"(9.52)	5/8"(15.87)	2	1
MWD/MCD530DB/D1 	36 1/16"(916)	40 3/4"(1034)	43 1/4"(1098)	20"(509) 	3/8"(9.52)	5/8"(15.87)	2	1
MWD/MCD536DB/D1 	42 1/16"(1069)	46 3/4"(1187)	49 1/4"(1251)	20"(509) 	3/8"(9.52)	3/4"(19.05)	2	1



# MCD Dimensional Data

## OUTLINE DIMENSION MCD030EB5 MCD512-536DB/D1

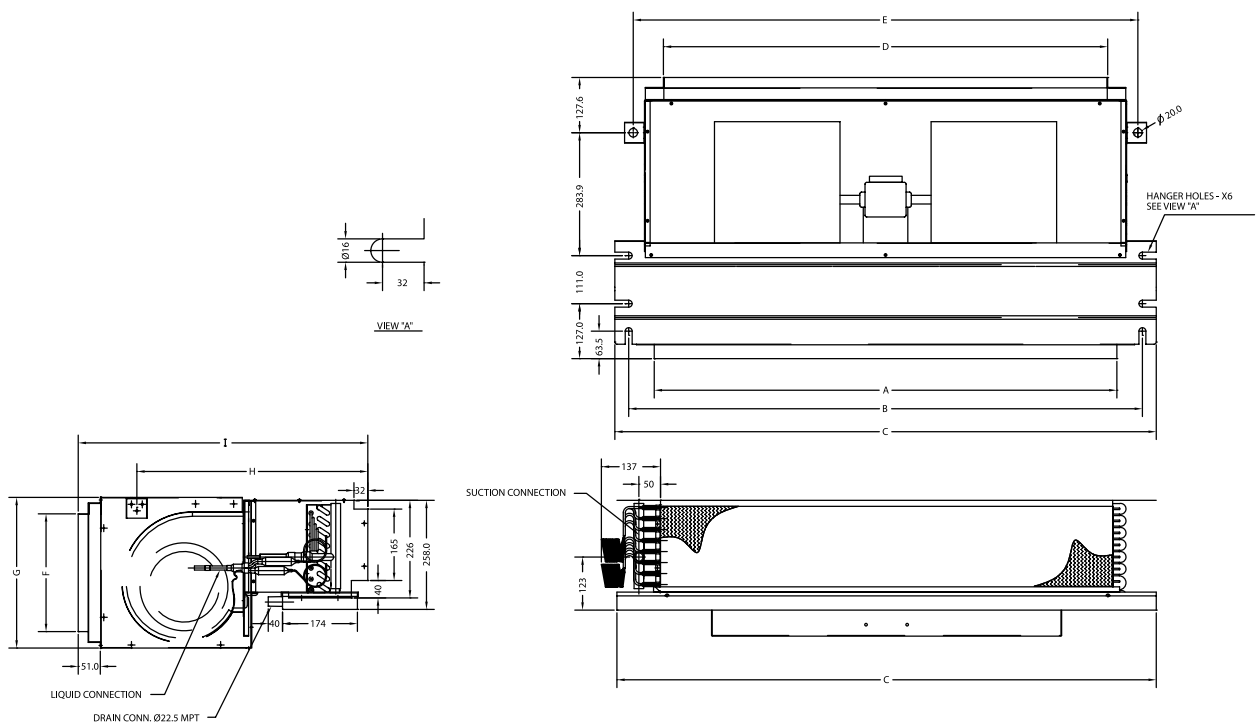

Model	All External Dimensions are in inch (mm.)					
	A	B	C	D	E	F
MCD512DB/D1	30 1/16"(764)	34 3/4"(882)	37 1/4"(946)	30 11/16"(779)	33 3/4"(857)	10 1/2"(266)
MCD518DB/D1	30 1/16"(764)	34 3/4"(882)	37 1/4"(946)	30 11/16"(779)	33 3/4"(857)	10 1/2"(266)
MCD524DB/D1	30 1/16"(764)	34 3/4"(882)	37 1/4"(946)	30 11/16"(779)	33 3/4"(857)	10 1/2"(266)
MCD530DB/D1	36 1/16"(916)	40 3/4"(1034)	43 1/4"(1098)	36 11/16"(931)	39 3/4"(1009)	10 1/2"(266)
MCD536DB/D1	42 1/16"(1069)	46 3/4"(1187)	49 1/4"(1251)	42 11/16"(1084)	45 3/4"(1162)	10 1/2"(266)
MCD030EB5	42 1/16"(1069)	46 3/4"(1187)	49 1/4"(1251)	42 11/16"(1084)	45 3/4"(1162)	10 3/4"(272)

Model	All External Dimensions are in inch (mm.)			Refrig Line Conn. Size.		Number Of	
	G	H	I	Liquid	Suction	Fan(s)	Motor(s)
MCD512DB/D1	11 3/4"(300)	19 1/4"(490)	24 5/8"(625)	1/4"(6.35)	1/2"(12.7)	2	1
MCD518DB/D1	11 3/4"(300)	19 1/4"(490)	24 5/8"(625)	1/4"(6.35)	1/2"(12.7)	2	1
MCD524DB/D1	11 3/4"(300)	19 1/4"(490)	24 5/8"(625)	3/8"(9.52)	5/8"(15.87)	2	1
MCD530DB/D1	11 3/4"(300)	19 1/4"(490)	24 5/8"(625)	3/8"(9.52)	5/8"(15.87)	2	1
MCD536DB/D1	11 3/4"(300)	19 1/4"(490)	24 5/8"(625)	3/8"(9.52)	3/4"(19.05)	2	1
MCD030EB5	13 3/4"(348)	21" (534)	26 5/8"(672)	3/8"(9.53)	3/4"(19.05)	2	1

# MCD Dimensional Data

## OUTLINE DIMENSION MCD036-042EB5 MCD048-00DB/D1

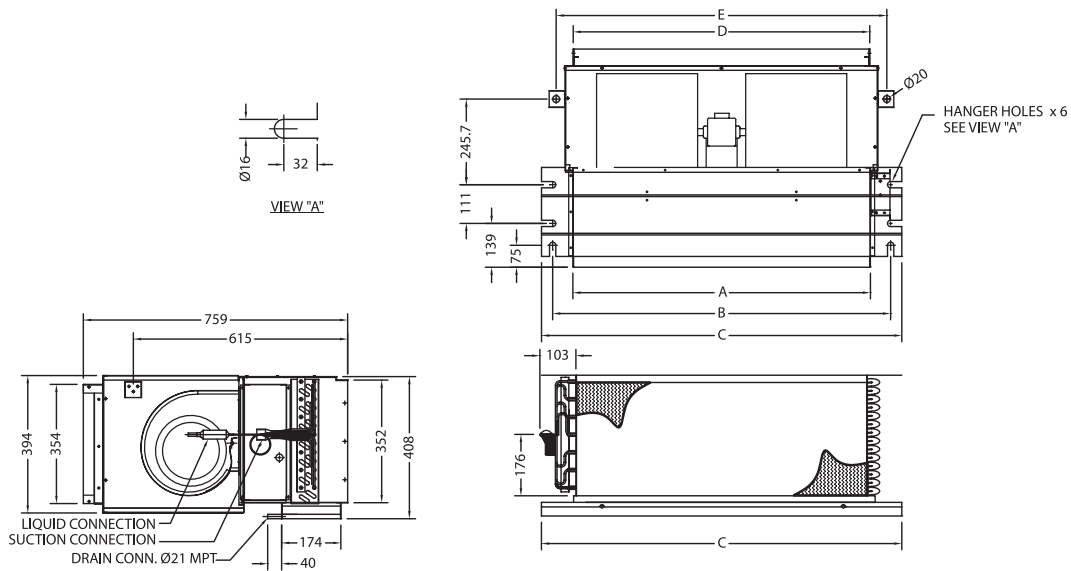

Model	All External Dimensions are in inch (mm)					Refrig. Line Conn. Size		Number Of	
	A	B	C	D	E	Liquid	Suction	Fan (s)	Motor (s)
MCD048DB/D1	36 1/16"(916)	40 3/4"(1034)	43 1/4"(1098)	35 3/4"(907)	39 7/8"(1013)	3/8"(9.53)	1 1/8"(28.6)	2	1
MCD060DB/D1	42 1/16"(1069)	46 3/4"(1187)	49 1/4"(1251)	41 3/4"(1060)	45. 7/8"(1166)	3/8"(9.53)	1 1/8"(28.6)	2	1
MCD036EB5	36 1/16"(916)	40 3/4"(1034)	43 1/4"(1098)	35 3/4"(907)	39 7/8"(1013)	3/8"(9.53)	3/4"(19.05)	2	1
MCD042EB5	36 1/16"(916)	40 3/4"(1034)	43 1/4"(1098)	35 3/4"(907)	39 7/8"(1013)	3/8"(9.53)	7/8"(22.23)	2	1

# TTK Dimensional Data

**OUTLINE DIMENSION**  
**TTK509-518LB5(50HZ)**  
**TTK512LB EX (50HZ)**  
**TTK512L1 EX (60HZ)**

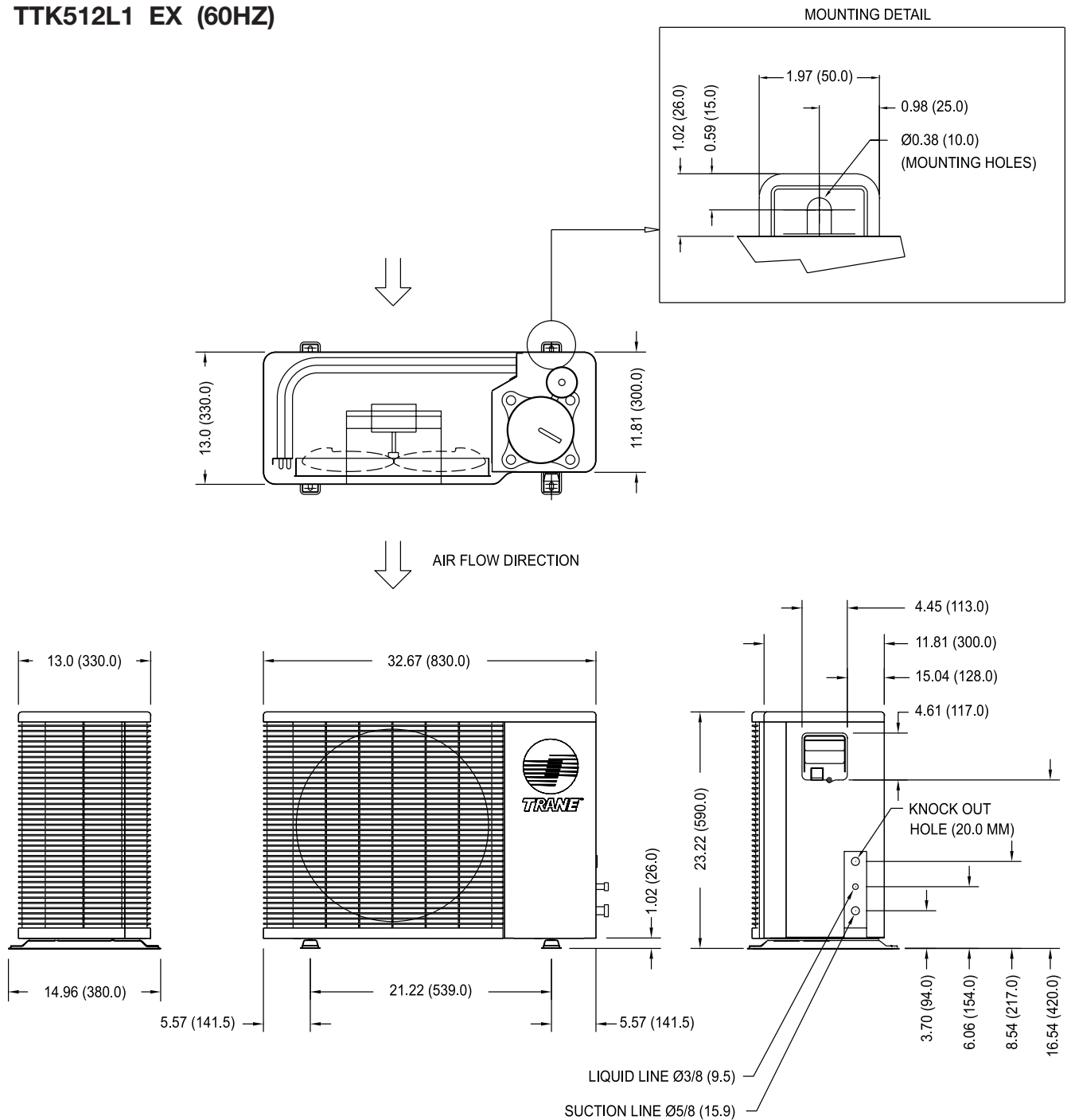

NOTE : DIMENSIONS ARE INCHE (MILIMETERS) ; 1 in = 25.40 mm

# TTK Dimensional Data

**OUTLINE DIMENSION**  
**TTK518-530PB(50HZ)**  
**TTK518LB5 (50HZ)**  
**TTK530PD(50HZ)**  
**TTK518-530P1(60HZ)**

MOUNTING DETAIL

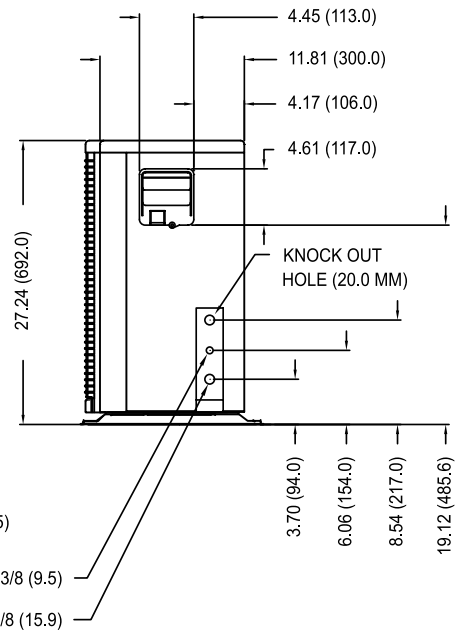
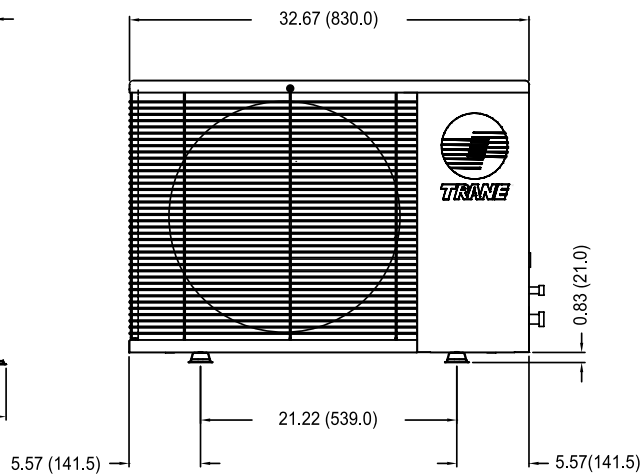
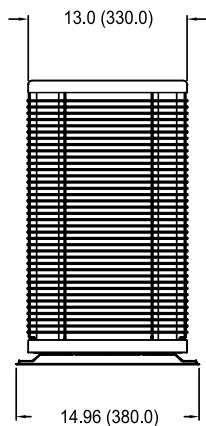
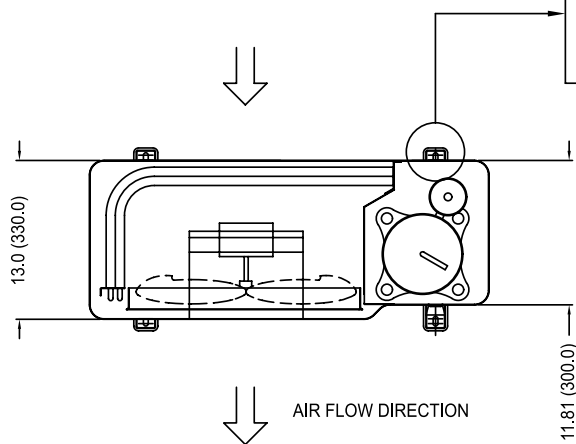
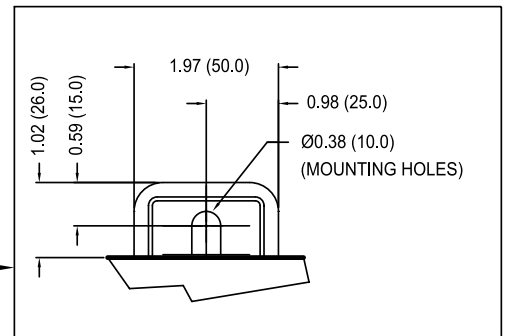

MODEL	REFRIG. LINE DIA.	
	LIQUID	SUCTION
TTK518PB/P1	1/4 (6.35)	1/2 (12.7)
TTK518LB5 TTK524-530PB TTK530PD TTK524-530P1	3/8 (9.5)	5/8 (15.9)

NOTE : DIMENSIONS ARE INCHES (MILLIMETERS) ; 1 in = 25.40 mm

# TTK Dimensional Data

## OUTLINE DIMENSION

TTK536KB(50HZ)

TTK536-060KD(50HZ)

TTK524LB5(50HZ)

TTK530-536KB5(50HZ)

TTK536-042KD5(50HZ)

TTK536-060K1 (60HZ)

TTK060K3 (60HZ)

TTK536-042K4(60HZ)

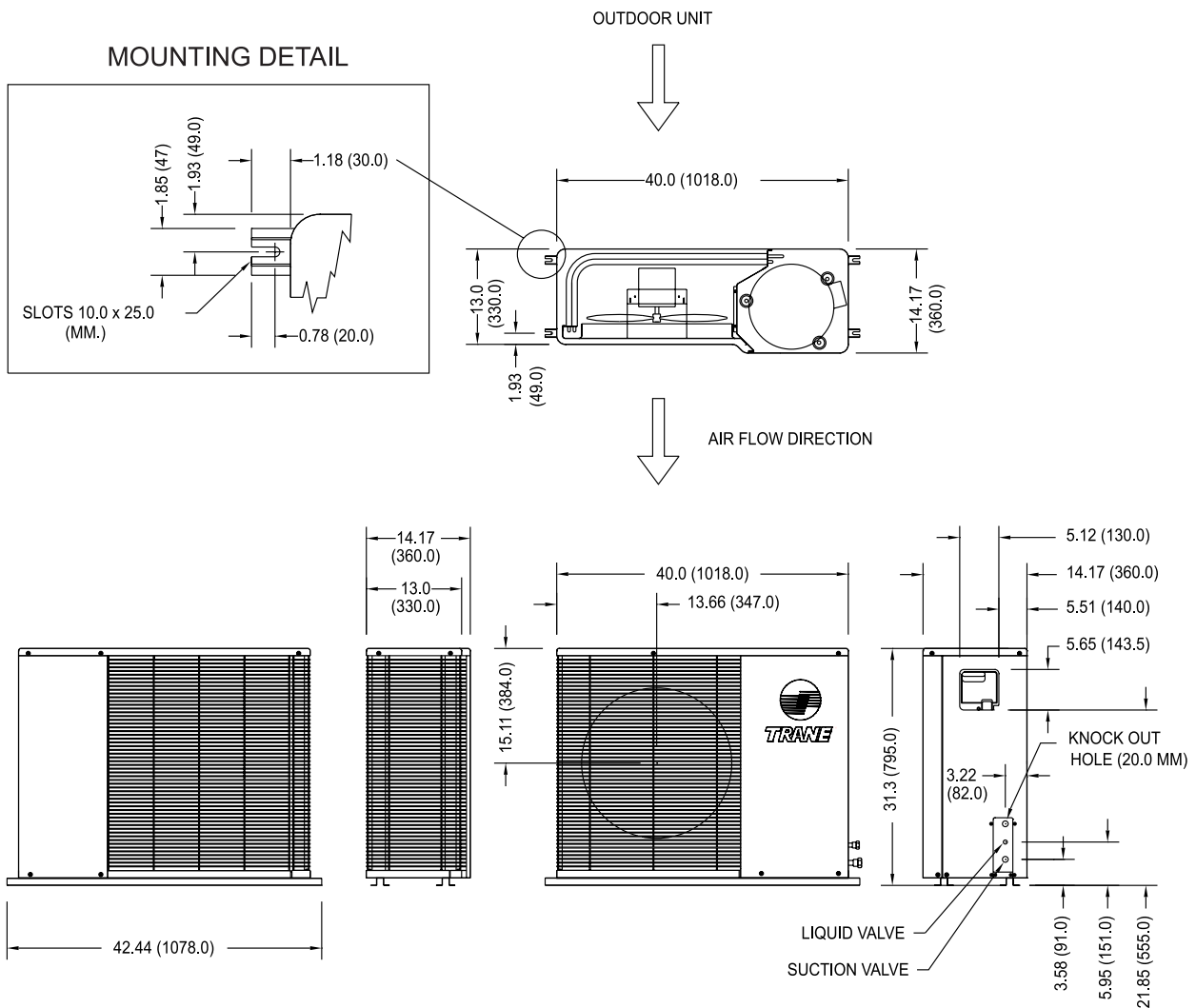

MODEL	REFRIG. LINE DIA.	
	LIQUID	SUCTION
TTK524LB5	3/8 (9.5)	5/8 (15.9)
TTK536KB/KD TTK536K1/K4 TTK530-536KB5 TTK536KD5	3/8 (9.5)	3/4 (19.1)
TTK042KD TTK042KD5 TTK042K1/K4	3/8 (9.5)	7/8 (22.2)
TTK048-060K1 TTK060K3 TTK048-060KD	3/8 (9.5)	1 1/8 (28.6)

NOTE : DIMENSIONS ARE INCHES (MILIMETERS) ; 1 in = 25.40 mm

# TTK Dimensional Data

## OUTLINE DIMENSION TTK048-060K4(60HZ)

## MOUNTING DETAIL

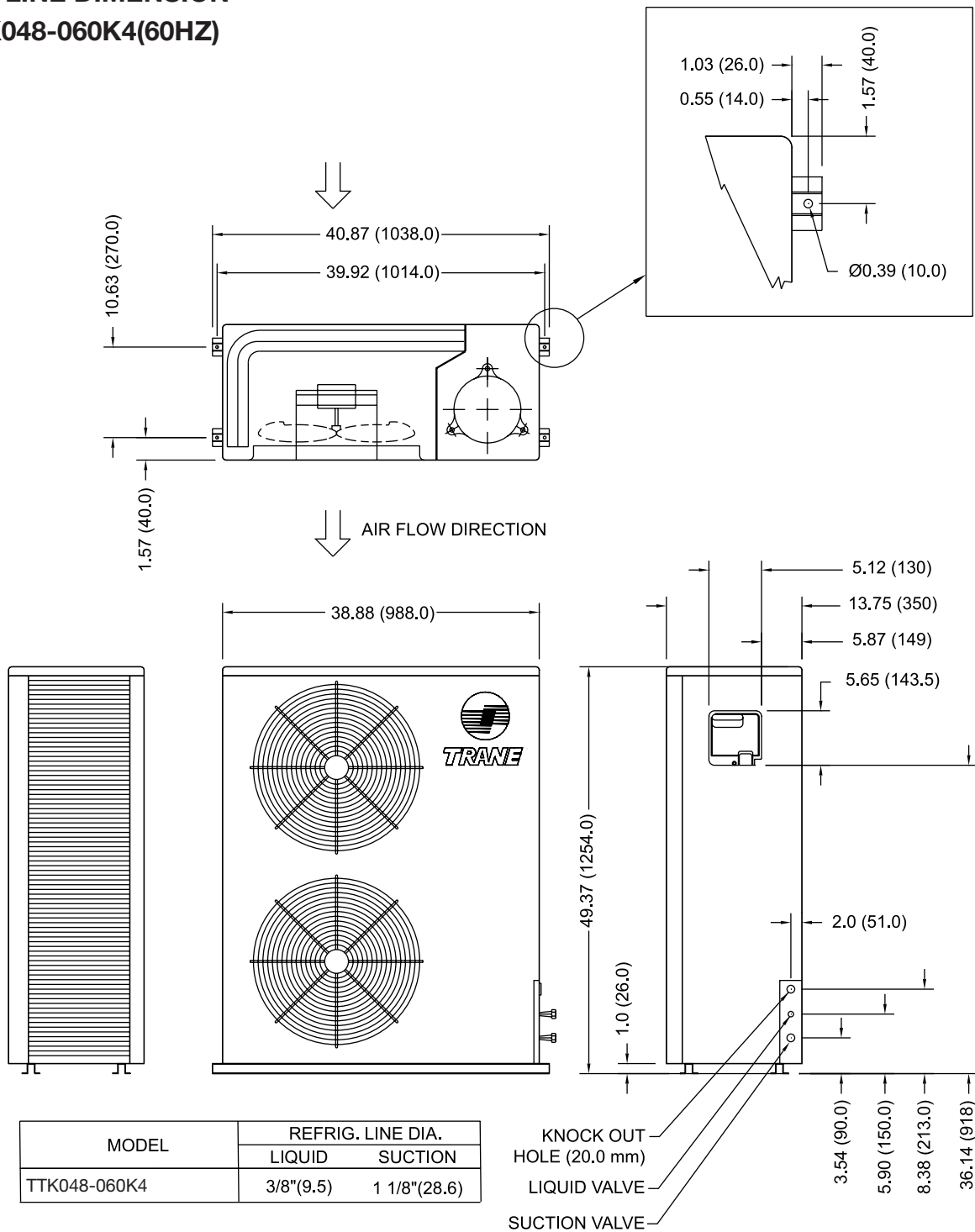

**NOTE** 1) SUCTION AND LIQUID VALVE ARE SWEAT TYPE CONNECTIONS.  
 2) DIMENSIONS : INCHES (MILIMETERS) ; 1 IN = 25.40 mm



Trane  
[www.trane.com](http://www.trane.com)

For more information, contact your local district office

---

Literature Order Number: SSA-PRC006-EN

---

Date: Mar 2011

---

Supersedes: December 2014

---

Stocking Location: Bangkok, Thailand

---

Trane has a policy of continuous product and product data improvement and reserves the right to change design and specifications without notice.