



RT-PRC020-EN

Package Two Stage Gas / Electric Units

Convertible Models
YCZ036,050,060F1/3/4

3, 4, 5 Ton

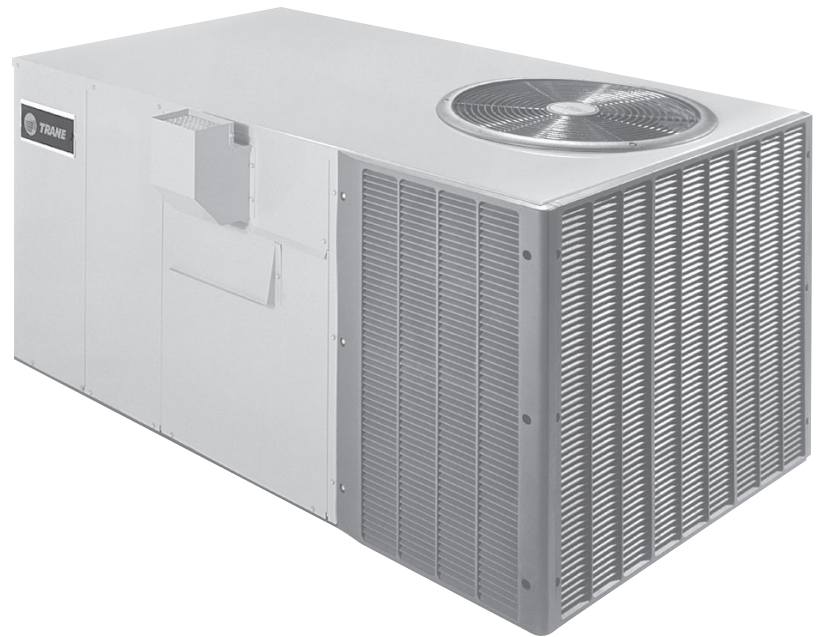

PUB. NO. 22-1684-03-0203 (EN)



General Features

It's Hard To Stop A Trane.®

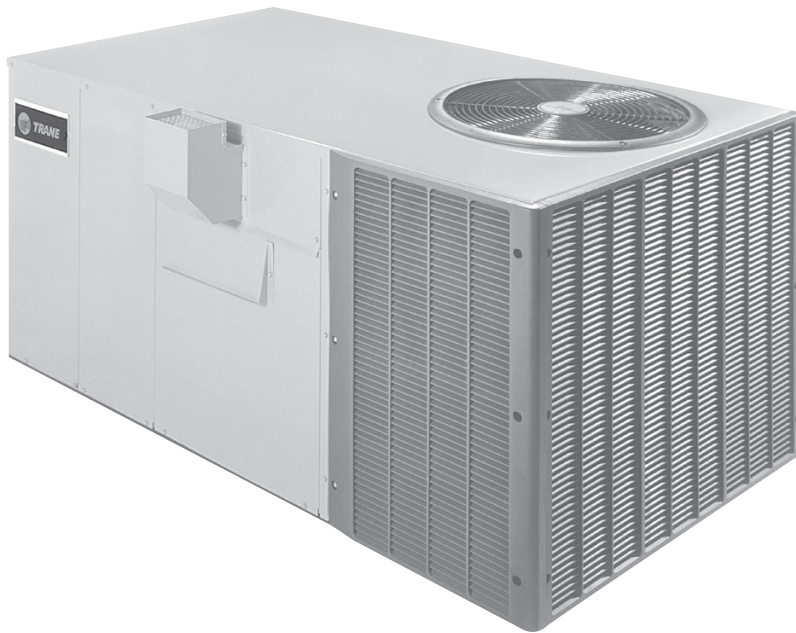

T-TOP™
COIL-SAV'R™ GRILLS
WEATHERGUARD™
Corrosion Resistant Screws
Powder Paint
WATER-SHED™ Base
High Efficiency

2-Climatuff® Compressors
DuraTuff™ Plate Fin Coil
Two Stage Gas Furnace
Side Electrical and Gas Access
Sloped Drain Pan
100% Foil Faced Insulation
Easy Access for Service and Installation

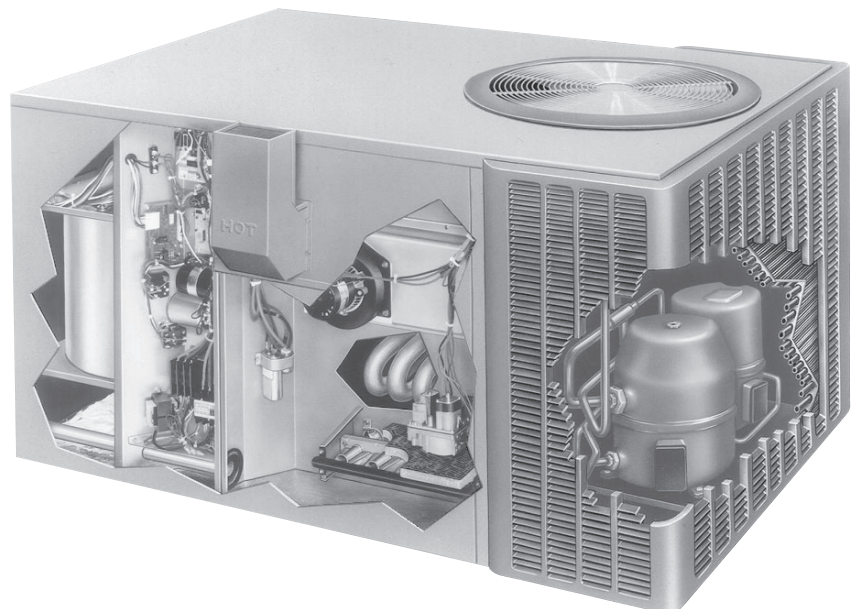

Features and Benefits

Contents

Standard Equipment

- **High Efficiency**
IMPACT performance is the highest in the industry at 16 SEER.

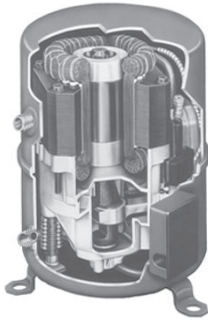

- **Two Climatuff® Compressors Two Stage Cooling**
Two stage operation for full and half cooling capacity. Protection against chemical, electrical, and mechanical stresses are built in for efficiency and a longer life. The compressors are backed by a 10-year limited warranty. (Single phase residential use only.)
- **Coil Guards**
The **COIL-SAV'R** end and side grilles are a new Lexan®, louvertype. The grilles will protect the coil from hail, kids with sticks, and normal shipping, installation and handling damage.
- **Powder Paint**
Beautiful high gloss silver gray finish blends with any architectural style. New powder paint covers surfaces uniformly increasing protection from rust and corrosion.
- **WEATHERGUARD™ Corrosion Resistant Screws**
Holds it all together beautifully. Resists rust and corrosion.
- **WATER-SHED Base**
Superior water integrity is accomplished with the **WATER-SHED** base pan having elevated downflow openings and a perimeter channel that prevents water from draining into the ductwork.
- **T-TOP™**
Exclusive one piece, solid unit top for improved water integrity and easy component access.
- **Two Stage Gas Furnace**
The furnace features aluminized tubular heat exchangers that have demonstrated their durability in torturous life cycle tests. The heat exchanger is backed by a 20-year limited warranty (residential use only).

(continued on page 4)

General Features

Features and Benefits

Standard Equipment
IMPACT Accessories

Selection Procedure

Model Number Nomenclature

Optional Equipment

General Data

YCZ036F1M0B
YCZ036F3M0B
YCZ036F4M0A
YCZ050F1H0A
YCZ050F3H0A
YCZ050F4H0A
YCZ060F1M0B
YCZ060F3M0B
YCZ060F4M0A

Performance Data

Cooling
Heating
Indoor Fan

Sequence Of Operation

Optional Equipment

Controls

Field Wiring

Typical Wiring

Dimensions

Mechanical Specification Options

2

3

3

5

5

5

6

7

7

7

7

8

8

8

9

9

9

10

10

13

14

15

17

18

19

20

22

28



Features and Benefits

Standard Equipment

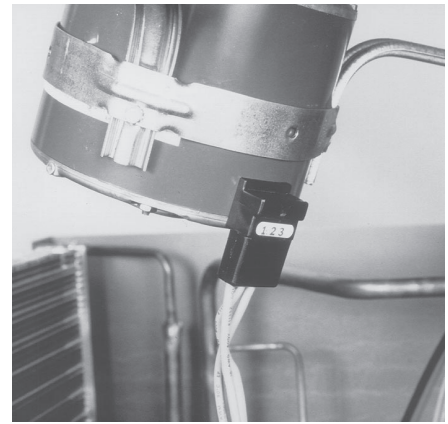

- **Venting**
Induced draft venting reduces combustion problems associated with high winds and combustion panels that have been improperly replaced.
- **California NOx**
The standard unit meets California NOx requirements eliminating the inventory problems associated with unique models or kits.
- **DuraTuff™ Plate Fin Coil**
Refrigeration coils are built with internally enhanced copper tubing for high efficiency with less coil area.
- **One for Us... Two for Customer**
Three-try direct spark ignition system eliminates pilot related problems and provides unsurpassed ignition reliability.
- **Exclusive Comfort-R™ System**
Provides better humidity control in cooling mode.
- **Commonality**
The common cabinet among the TCC's, WCX's, and YCY's minimizes both the training of sales and service personnel and replacement parts inventory.
- **Easy Access**
All electrical components can be diagnosed and replaced with the removal of one panel that is attached with two screws.
- **Flexibility**
A single curb fits the entire IMPACK line from 1.5 tons through 5 tons thereby providing great installation flexibility on shopping malls, factories, schools, and other commercial buildings where a mix-match of tonnages and utilities is desired.
- **Shipping**
Unit dimensions were carefully selected to provide an attractive aspect ratio and for shipping and handling considerations.
- **Good Neighbor**
Most units can be installed flush with the residence or building thereby minimizing the ground space required. Blankets of insulation reduce blower noise and energy losses to the outside environments.
- **Rooftop Mounting**
The cabinets are physically smaller than most competitive models. This means less intrusive installations on residential rooftops where aesthetics are critical.
- **Convertibility**
IMPACT units are easily converted from horizontal to down flow with the removal of one screw from each panel. Accordingly, the need to stock both dedicated horizontal and dedicated down flow models has been eliminated.
- **Installation**
The ease of installation and application flexibility exhibited through the design reduce both field time and material.
- **Structure**
The units are lighter weight through the use of high technology components thereby reducing mounting structure requirements and difficulty when manhandling.
- **Handling**
The three-way wooden skid allows for easy loading between the wheel wells on pickup trucks for transporting to job sites.
- **Application**
The low profile horizontal duct take-offs eliminate the need for expensive transition ducts in crawl space applications.
- **Duct Flanges**
Only IMPACK has downflow duct flanges for duct attachments that preserve the built-in water integrity.
- **Service**
All wiring is both numbered and color coded thereby reducing training and servicing costs related to circuit tracing and components replacements.
- **Maintenance**
A plug on the outdoor fan motor allows the top cover to be removed completely without the hassle of cumbersome wires. The unique service orifice ring allows the indoor fan motor/blower to be removed as a unit.
- **Corrosion**
The drain pan is engineered material and eliminates the need for coatings and sealers to prevent sweating and corrosion. The heavy gauge, zinc-coated steel cabinet has a weather resistant enamel finish that stays attractive and protects your investment for years.
- **Low Ambient Control**
Standard cooling operation to 45° F as shipped, zero degree ambient cooling is accomplished with two kits. One for low cost installations when full tonnage is not needed. The other kit maintains head pressure and full capacity at zero degrees.
- **Quality and Reliability Testing**
We perform a 100% coil leak test at the factory. The evaporator and condenser coils are leak tested at 200 psig and pressure tested to 450 psig respectively. In addition the IMPACK designs were rigorously rain tested at the factory to ensure water integrity. Shipping tests are performed to determine packaging requirements. Factory shake and drop tests are used as part of the package design process to help assure that the unit will arrive at the job site in top condition. Additionally, all components are inspected at the point of final assembly. Substandard parts and components are identified and rejected immediately. Every unit receives a 100% run test before leaving the production line to make sure it lives up to rigorous Trane requirements. We at Trane test our designs at our factory and not on our customers!



Optional Equipment

OPTIONAL EQUIPMENT FOR PACKAGED UNITS

(check mark [✓] indicates accessories included)

Indoor Thermostats — Prog. Auto. 2-Stage Htg/Clg w/ Econ.	TAYSTAT302C	[]
Electronic 2 Htg/2 Clg Auto (Non-prog.)	TAYSTAT375	[]
Outdoor Temp. Sensor (TAYSTAT302C,375)	TAYSENS100A	[]
Locking Thermostat Cover (Thermostats)	BAY28X190	[]
Humidistat	BAYSTAT253	[]
Roof Curb Full Perimeter (YCZ036F) ③	BAYCURB033A	[]
Roof Curb Full Perimeter (YCZ050-60F) ③	BAYCURB034A	[]
0-25% Manual Fresh Air Damper (YCZ036F) ①	BAYDMPR040A	[]
0-25% Manual Fresh Air Damper (YCZ050-60F) ①	BAYDMPR041A	[]
12" Round Duct Adapter (2 per box) (YCZ036F)	BAYDUCT004A	[]
14" Round Duct Adapter (1 per box) (YCZ036F)	BAYDUCT005A	[]
0-100% Mod Economizer w/Baro. Relief (YCZ036F) ①②④	BAYECON054B	[]
0-100% Mod. Economizer w/Baro. Relief (YCZ050-60F) ①②④	BAYECON055B	[]
0-100% Horizontal Economizer ①②	BAYECON073A	[]
Enthalpy Control for Economizer (solid state)	BAYENTH001A	[]
Remote Potentiometer (BAYECON054,055A,073A)	BAYSTAT023	[]
Outside Air Control for V.S.Economizer	BAYOSAC001A	[]
Filter Frame (YCYZ036F) (20x25x1) ①	BAYFLTR013A	[]
Filter Frame (YCZ050-60F) (3-10x25x1) ①	BAYFLTR014A	[]
Filter Frame (YCZ036F) (20x25x2) ①	BAYFLTR018A	[]
Filter Frame (YCZ050-60F) (2-16x25x2) ①	BAYFLTR019A	[]
LP Conversion Kit	BAYLPKT024A	[]
LP Conversion Kit w/Stainless Steel Burners	BAYLPSS002A	[]
Lifting Lug Kit	BAYLIFT002A	[]
Evaporator Defrost Control (Low Ambient Cooling) Kit	BAYLOAM011A	[]
Head Pressure Control (Low Ambient Cool) (208/240v) Kit ⑤	BAYLOAM323A	[]
Low Ambient Motor (208/230) ⑤	BAYMOTR307A	[]
Low Ambient Motor (460v) ⑤	BAYMOTR406A	[]

Notes:

- ① Must use filter frame when economizer/fresh air kit is used.
- ② Dry bulb control standard with economizer.
- ③ Ships knocked down.
- ④ Downflow only.
- ⑤ Use Low Ambient Motor With This Kit on YCZ036F models.



General Data

MODEL	YCZ036F1M0B	YCZ036F3M0B	YCZ036F4M0A
RATED VOLTS/PH/Hz	208-230/1/60	208-230/3/60	460/3/60
RATINGS (COOLING) ①			
BTUH (HIGH)	36000	36000	36000
Indoor Airflow (CFM)	1200	1200	1200
Power Input (KW)	3.00	3.00	3.28
BTUH (LOW)	20400	20400	20800
Indoor Airflow (CFM)	800	800	800
Power Input (KW)	1.57	1.57	1.64
EER - HI/LOW	12.00 / 13.00	12.00 / 13.00	11.70 / 12.40
SEER (BTU/Watt-Hr.)	16.05	16.05	15.60
Noise Rating No. ①	8.0	8.0	8.0
A.G.A. RATINGS (HEATING) ②			
(High) Input BTUH	72000	72000	72000
Capacity BTUH ⑤⑦	57000	57000	57000
AFUE/CSE*	80% / 76%	80% / 76%	80%/76%
Temp. Rise °F. (Min./Max.)	30 - 60	30 - 60	30 - 60
(Low) Input BTUH	56000	56000	56000
Capacity BTUH ⑤⑦	45000	45000	45000
AFUE/CSE*	80% / 76%	80% / 76%	80%/76%
Temp. Rise °F. (Min./Max.)	30 - 60	30 - 60	30 - 60
Type of Gas ③	NATURAL	NATURAL	NATURAL
NOx (ngm/joule)	<40*	<40*	<40*
POWER CONNS.—V/PH/Hz	208-230/1/60	208-230/1/60	460/3/60
Min. Brch. Cir. Ampacity	27.1	19.6	11.4
Br. Cir.—Max. (Amps)	40	30	15
Prot. Rtq.—Min. (Amps)	40	30	15
COMPRESSOR	CLIMATUFF®	CLIMATUFF®	CLIMATUFF®
No. Used	2	2	2
Volts/Ph/Hz (HIGH)	200-230/1/60	200-230/3/60	460/3/60
R.L. Amps—L.R. Amps	13.9 - 91	11.2 - 101.0	6.4 - 46
Volts/PH/Hz (LOW)	200-230/1/60	200-230/1/60	460/3/60
R.L. Amps—L.R. Amps	7.7 - 41	7.7 - 41	3.2 - 31
OUTDOOR COIL—TYPE	PLATE FIN	PLATE FIN	PLATE FIN
Rows / F.P.I.	2 / 22	2 / 22	2 / 22
Face Area (Sq. Ft.)	11.35	11.35	11.35
Tube Size (In.)	3/8	3/8	3/8
INDOOR COIL—TYPE	PLATE FIN	PLATE FIN	PLATE FIN
Rows / F.P.I.	4 / 15	4 / 15	4 / 15
Face Area (Sq. Ft.)	4.28	4.28	4.28
Tube Size (In.)	3/8	3/8	3/8
Refrigerant Control	TXV-NB	TXV-NB	TXV-NB
Drain Conn. Size (in.)	3/4" FEMALE	3/4" FEMALE	3/4" FEMALE
Duct Connections	SEE OUTLINE DRAWING	SEE OUTLINE DRAWING	SEE OUTLINE DRAWING
OUTDOOR FAN—TYPE	PROPELLER	PROPELLER	PROPELLER
No. Used / Dia. (in.)	1 / 18	1 / 18	1 / 18
Type Drive / No. Speeds	DIRECT / 2	DIRECT / 2	DIRECT / 2
No. Motors—HP	1 - 1/5	1 - 1/5	1 - 1/6
Motor Speed R.P.M.	1080	1080	1100
Volts/PH/Hz	230/1/60	230/1/60	460/1/60
F.L. Amps	1.3	1.3	0.6
INDOOR FAN—TYPE	CENTRIFUGAL	CENTRIFUGAL	CENTRIFUGAL
Dia. x Width (in.)	10 X 9	10 X 9	10 X 9
No. Used	1	1	1
Drive / Speeds (No.)	DIRECT	DIRECT	DIRECT
No. Motors—HP	1 - 1/2	1 - 1/2	1 - 1/2
Motor Speed R.P.M.	VARIABLE	VARIABLE	VARIABLE
Volts/PH/Hz	200/230/1/60	200/230/1/60	200/230/1/60
F.L. Amps	4.3	4.3	4.3
COMBUSTION FAN—TYPE	CENTRIFUGAL	CENTRIFUGAL	CENTRIFUGAL
Drive—Speeds (No.)	DIRECT - 2	DIRECT - 2	DIRECT - 2
Motor HP—Speed (RPM)	1/100 - 2920	1/100 - 2920	1/100 - 2920
Volts/PH/Hz	208/230/1/60	208/230/1/60	208/230/1/60
F.L. Amps	.18	.18	.18
FILTER—FURNISHED?	NO	NO	NO
Type Recommended	THROWAWAY	THROWAWAY	THROWAWAY
Min Face Area - Lo (Sq. Ft.) ⑤	3.47	3.47	3.47
REFRIGERANT			
Charge (lbs. of R-22) ④	10 LBS., 0 OZ.	10 LBS., 0 OZ.	10 LBS., 0OZ.
GAS PIPE SIZE (IN.)	1/2"	1/2"	1/2"
DIMENSIONS			
Crated (in.)	H X W X D 35-1/4 X 38 X 64-5/8	H X W X D 35-1/4 X 38 X 64-5/8	H X W X D 35-1/4 X 38 X 64-5/8
Uncrated	SEE OUTLINE DRAWING	SEE OUTLINE DRAWING	SEE OUTLINE DRAWING
WEIGHT			
Shipping (lbs.) / Net (lbs.)	588 / 528	588 / 528	613 / 553

*See unit nameplate for proper input adjustment.



General Data

MODEL	YCZ050F1H0A	YCZ050F3H0A	YCZ050F4H0A
RATED VOLTS/PH/Hz	208-230/1/60	208-230/3/60	460/3/60
RATINGS (COOLING) ①			
BTUH (HIGH)	51000	51000	51000
Indoor Airflow (CFM)	1600	1600	1600
Power Input (KW)	4.43	4.43	4.44
BTUH (LOW)	28000	28000	29000
Indoor Airflow (CFM)	1000	1000	1000
Power Input (KW)	2.00	2.00	2.13
EER - HI/LOW	11.5 / 14.00	11.5 / 14.0	11.5 / 13.70
SEER (BTU/Watt-Hr.)	16.00	16.00	15.75
Noise Rating No. ①	8.2	8.2	8.2
A.G.A. RATINGS (HEATING) ②			
(High) Input BTUH	120000	120000	120000
Capacity BTUH ⑤⑦	95500	95500	95000
AFUE/CSE*	80% / 76%	80% / 76%	80%/76%
Temp. Rise °F. (Min./Max.)	35 - 65	35 - 65	35 - 65
(Low) Input BTUH	90000	90000	90000
Capacity BTUH ⑤⑦	73000	73000	73000
AFUE/CSE*	80% / 76%	80% / 76%	80%/76%
Temp. Rise °F. (Min./Max.)	35 - 65	35 - 65	30 - 60
Type of Gas ③	NATURAL	NATURAL	NATURAL
NOx (ngm/joule)	<40*	<40*	<40*
POWER CONNS.—V/PH/Hz			
Min. Brch. Cir. Ampacity	208-230/1/60	208-230/1/60	460/3/60
Br. Cir.—Max. (Amps)	32	25.5	15.1
Prot. Rtq.—Min. (Amps)	40	30	20
	40	30	20
COMPRESSOR			
	CLIMATUFF®	CLIMATUFF®	CLIMATUFF®
No. Used	2	2	2
Volts/Ph/Hz (HIGH)	200-230/1/60	200-230/3/60	460/3/60
R.L. Amps—L.R. Amps	8.7 - 62	7.4 - 61	3.9 - 31
Volts/PH/Hz (LOW)	200-230/1/60	200-230/3/60	460/3/60
R.L. Amps—L.R. Amps	8.7 - 62	7.4 - 61	3.9 - 31
OUTDOOR COIL—TYPE			
	PLATE FIN	PLATE FIN	PLATE FIN
Rows / F.P.I.	2 / 22	2 / 22	2 / 22
Face Area (Sq. Ft.)	15.0	15.0	15.0
Tube Size (In.)	3/8	3/8	3/8
INDOOR COIL—TYPE			
	PLATE FIN	PLATE FIN	PLATE FIN
Rows / F.P.I.	4 / 15	4 / 15	4 / 15
Face Area (Sq. Ft.)	5.4	5.4	5.4
Tube Size (In.)	3/8	3/8	3/8
Refrigerant Control	TXV-NB	TXV-NB	TXV-NB
Drain Conn. Size (in.)	3/4" FEMALE	3/4" FEMALE	3/4" FEMALE
Duct Connections	SEE OUTLINE DRAWING	SEE OUTLINE DRAWING	SEE OUTLINE DRAWING
OUTDOOR FAN—TYPE			
	PROPELLER	PROPELLER	PROPELLER
No. Used / Dia. (in.)	1 / 24	1 / 24	1 / 24
Type Drive / No. Speeds	DIRECT / 2	DIRECT / 2	DIRECT / 2
No. Motors—HP	1 - 1/4	1 - 1/4	1 - 1/4
Motor Speed R.P.M.	840	840	825
Volts/PH/Hz	230/1/60	230/1/60	460/1/60
FL. Amps	2.0	2.0	0.9
INDOOR FAN—TYPE			
	CENTRIFUGAL	CENTRIFUGAL	CENTRIFUGAL
Dia. x Width (in.)	11 X 11	11 X 11	11 X 11
No. Used	1	1	1
Drive / Speeds (No.)	DIRECT	DIRECT	DIRECT
No. Motors—HP	1 - 3/4	1 - 3/4	1 - 3/4
Motor Speed R.P.M.	VARIABLE	VARIABLE	VARIABLE
Volts/PH/Hz	200/230/1/60	200/230/1/60	200/230/1/60
FL. Amps	6.8	6.8	6.8
COMBUSTION FAN—TYPE			
	CENTRIFUGAL	CENTRIFUGAL	CENTRIFUGAL
Drive—Speeds (No.)	DIRECT - 2	DIRECT - 2	DIRECT - 2
Motor HP—Speed (RPM)	1/45 - 2800	1/45 - 2800	1/45 - 2800
Volts/PH/Hz	208/230/1/60	208/230/1/60	208/230/1/60
FL. Amps	.22	.22	.22
FILTER—FURNISHED?			
	NO	NO	NO
Type Recommended	THROWAWAY	THROWAWAY	THROWAWAY
Min Face Area - Lo (Sq. Ft.) ⑤	5.33	5.33	5.33
REFRIGERANT			
Charge (lbs. of R-22) ④	11.8 LBS.	11.8 LBS.	11.8 LBS.
GAS PIPE SIZE (IN.)			
	1/2"	1/2"	1/2"
DIMENSIONS			
Crated (in.)	H X W X D 39-3/8 X 47 X 64-1/4	H X W X D 39-3/8 X 47 X 64-1/4	H X W X D 39-3/8 X 47 X 64-1/4
Uncrated	SEE OUTLINE DRAWING	SEE OUTLINE DRAWING	SEE OUTLINE DRAWING
WEIGHT			
Shipping (lbs.) / Net (lbs.)	693 / 626	693 / 626	718 / 651

*See unit nameplate for proper input adjustment.



General Data

MODEL	YCZ060F1M0B	YCZ060F3M0B	YCZ060F4M0A
RATED VOLTS/PH/Hz	208-230/1/60	208-230/3/60	460/3/60
RATINGS (COOLING) ①			
BTUH (HIGH)	59000	59000	59000
Indoor Airflow (CFM)	2000	2000	2000
Power Input (KW)	5.36	5.36	5.47
BTUH (LOW)	29800	29800	29200
Indoor Airflow (CFM)	1100	1100	1100
Power Input (KW)	2.29	2.29	2.23
EER - HI/LOW	11.0 / 13.0	11.0 / 13.0	10.90 / 13.18
SEER (BTU/Watt-Hr.)	15.20	15.20	14.85
Noise Rating No. ①	8.2	8.2	8.2
A.G.A. RATINGS (HEATING) ②			
(High) Input BTUH	120000	120000	120000
Capacity BTUH ⑤⑦	96000	96000	96000
AFUE/CSE*	80% / 76%	80% / 76%	80%/76%
Temp. Rise °F. (Min./Max.)	30 - 60	30 - 60	30 - 60
(Low) Input BTUH	90000	90000	90000
Capacity BTUH ⑤⑦	72000	72000	72000
AFUE/CSE*	80% / 76%	80% / 76%	80%/76%
Temp. Rise °F. (Min./Max.)	30 - 60	30 - 60	30 - 60
Type of Gas ③	NATURAL	NATURAL	NATURAL
NOx (ngm/joule)	<40*	<40*	<40*
POWER CONNS.—V/PH/Hz			
Min. Brch. Cir. Ampacity	208-230/1/60 43.5	208-230/1/60 30.9	460/3/60 20.3
Br. Cir.—Max. (Amps)	70	45	30
Prot. Rtg.—Min. (Amps)	70	45	30
COMPRESSOR			
	CLIMATUFF®	CLIMATUFF®	CLIMATUFF®
No. Used	2	2	2
Volts/Ph/Hz (HIGH)	200-230/1/60	200-230/3/60	460/3/60
R.L. Amps—L.R. Amps	22.1 - 145.0	17.6 - 118.0	10.3 - 71
Volts/PH/Hz (LOW)	200-230/1/60	200-230/1/60	460/3/60
R.L. Amps—L.R. Amps	11.0 - 57	11.0 - 57	3.9 - 31
OUTDOOR COIL—TYPE			
	PLATE FIN	PLATE FIN	PLATE FIN
Rows / F.P.I.	2 / 22	2 / 22	2 / 22
Face Area (Sq. Ft.)	15.0	15.0	15.0
Tube Size (In.)	3/8	3/8	3/8
INDOOR COIL—TYPE			
	PLATE FIN	PLATE FIN	PLATE FIN
Rows / F.P.I.	4 / 15	4 / 15	4 / 15
Face Area (Sq. Ft.)	5.4	5.4	5.4
Tube Size (In.)	3/8	3/8	3/8
Refrigerant Control	TXV-NB	TXV-NB	TXV-NB
Drain Conn. Size (in.)	3/4" FEMALE	3/4" FEMALE	3/4" FEMALE
Duct Connections	SEE OUTLINE DRAWING	SEE OUTLINE DRAWING	SEE OUTLINE DRAWING
OUTDOOR FAN—TYPE			
	PROPELLER	PROPELLER	PROPELLER
No. Used / Dia. (in.)	1 / 24	1 / 24	1 / 24
Type Drive / No. Speeds	DIRECT / 2	DIRECT / 2	DIRECT / 2
No. Motors—HP	1 - 1/4	1 - 1/4	1 - 1/4
Motor Speed R.P.M.	840	840	825
Volts/PH/Hz	230/1/60	230/1/60	460/1/60
F.L. Amps	2.0	2.0	0.9
INDOOR FAN—TYPE			
	CENTRIFUGAL	CENTRIFUGAL	CENTRIFUGAL
Dia. x Width (in.)	11 X 11	11 X 11	11 X 11
No. Used	1	1	1
Drive / Speeds (No.)	DIRECT	DIRECT	DIRECT
No. Motors—HP	1 - 1	1 - 1	1 - 1
Motor Speed R.P.M.	VARIABLE	VARIABLE	VARIABLE
Volts/PH/Hz	200/230/1/60	200/230/1/60	200/230/1/60
F.L. Amps	6.9	6.9	6.9
COMBUSTION FAN—TYPE			
	CENTRIFUGAL	CENTRIFUGAL	CENTRIFUGAL
Drive—Speeds (No.)	DIRECT - 2	DIRECT - 2	DIRECT - 2
Motor HP—Speed (RPM)	1/45 - 2800	1/45 - 2800	1/45 - 2800
Volts/PH/Hz	208/230/1/60	208/230/1/60	208/230/1/60
F.L. Amps	.22	.22	.22
FILTER—FURNISHED?			
Type Recommended	NO	NO	NO
Min Face Area - Lo (Sq. Ft.) ⑤	THROWAWAY 6.67	THROWAWAY 6.67	THROWAWAY 6.67
REFRIGERANT			
Charge (lbs. of R-22) ④	12 LBS, 13 OZ.	12 LBS, 13 OZ.	12 LBS, 13 OZ.
GAS PIPE SIZE (IN.)			
	1/2"	1/2"	1/2"
DIMENSIONS			
Crated (in.)	H X W X D 39-3/8 X 47X 64-1/4	H X W X D 39-3/8 X 47X 64-1/4	H X W X D 39-3/8 X 47X 64-1/4
Uncrated	SEE OUTLINE DRAWING	SEE OUTLINE DRAWING	SEE OUTLINE DRAWING
WEIGHT			
Shipping (lbs.) / Net (lbs.)	723 / 656	723 / 650	748 / 675

- ① Certified in accordance with the Unitary Air-Conditioner Equipment certification program, which is based on ARI Standard 210/240. Noise calculated in accordance with A.R.I. Standard 270. A.R.I. standard rating conditions are: 80 D.B. 67 W.B. entering air to indoor coil. 95 D.B. entering air to outdoor coil.
- ② All models are UL Listed. Ratings shown are for elevations up to 2000 ft. For higher elevations reduce ratings at a rate of 4% per 1000 ft. elevation.
- ③ Convertible to LPG.
- ④ This value is approximate. For more precise value, see Unit Nameplate.
- ⑤ Based on U.S. Government Standard Tests.
- ⑥ Filters must be installed in return air stream. Square footages listed are based on 300 f.p.m. face velocity. If permanent filters are used size per manufacturer's recommendation with a clean resistance of 0.05" W.C.
- ⑦ Check Unit Nameplate Unit for as shipped input, unit is convertible with a factory supplied orifice change to other input.

*See unit nameplate for proper input adjustment.



Performance Data Cooling

YCZ036F—B AT 1200 CFM

(CAPACITIES ARE NET IN BTUH/1000-INDOOR FAN HEAT DEDUCTED)

O.D. D.B.	I.D. W.B.	TOTAL CAP.	SENS. CAP. AT ENTERING D.B. TEMP.					COMPR. KW	APP.DEW PT.	CORRECTION FACTORS - OTHER AIRFLOWS (multiply or add as indicated)		
			72	74	76	78	80					
85	59	36.4	27.8	30.0	32.1	34.2	36.3	2.33	43.4	AIRFLOW 1050 1350 TOTAL CAP. X0.99 X1.01 SENS. CAP. X0.95 X1.05 COMPR. KW X1.00 X1.00 A.D.P. -1.5 +1.2		
	63	38.8	23.6	25.7	27.8	29.9	32.0	2.36	47.4			
	67	41.4	18.9	21.0	23.1	25.2	27.3	2.40	51.7			
	71	44.0	14.0	16.1	18.3	20.4	22.5	2.44	56.1			
90	59	33.8	26.7	28.8	31.0	33.1	34.3*	2.35	44.6	VALUES AT ARI RATING CONDITIONS TOTAL NET CAPACITY = 36000 BTUH AIRFLOW = 1200 CFM APP. DEW PT. = 54.0 DEG. F COMPRESSOR POWER = 2480 WATTS I.D. FAN POWER = 280 WATTS O.D. FAN POWER = 240 WATTS * DRY COIL CONDITION (TOTAL CAPACITY = SENSIBLE CAPACITY) TOTAL CAPACITY, COMP. KW AND APP. DEW PT. ARE VALID ONLY FOR WET COIL ALL TEMPERATURES IN DEGREES F.		
	63	36.2	22.5	24.6	26.7	28.8	30.9	2.39	48.6			
	67	38.7	17.8	19.9	22.1	24.2	26.3	2.44	52.9			
	71	41.2	13.0	15.2	17.3	19.4	21.5	2.49	57.2			
95	59	31.3	25.6	27.7	29.8	31.5*	32.3*	2.37	45.9			
	63	33.6	21.4	23.5	25.6	27.8	29.9	2.42	49.8			
	67	36.0	16.8	18.9	21.0	23.1	25.3	2.48	54.0			
	71	38.4	12.1	14.2	16.3	18.4	20.5	2.54	58.3			
100	59	28.7	24.5	26.6	28.7*	29.5*	30.2*	2.39	47.1			
	63	30.9	20.3	22.4	24.6	26.7	28.8	2.45	51.0			
	67	33.3	15.8	17.9	20.0	22.1	24.2	2.52	55.1			
	71	35.7	11.1	13.2	15.3	17.4	19.6	2.58	59.4			
105	59	26.2	23.4	25.5	26.7*	27.4*	28.2*	2.41	48.3			
	63	28.3	19.2	21.4	23.5	25.6	27.7	2.48	52.1			
	67	30.6	14.7	16.8	19.0	21.1	23.2	2.56	56.3			
	71	32.9	10.1	12.2	14.3	16.5	18.6	2.63	60.5			
115	59	21.0	21.9*	21.9*	22.7*	23.4*	24.1*	2.46	50.7			
	63	23.1	17.1	19.2	21.3	23.4*	24.1*	2.54	54.5			
	67	25.2	12.7	14.8	16.9	19.0	21.1	2.63	58.6			
	71	27.4	8.1	10.3	12.4	14.5	16.6	2.73	62.7			

YCZ036F—B AT 800 CFM

(CAPACITIES ARE NET IN BTUH/1000-INDOOR FAN HEAT DEDUCTED)

O.D. D.B.	I.D. W.B.	TOTAL CAP.	SENS. CAP. AT ENTERING D.B. TEMP.					COMPR. KW	APP.DEW PT.	CORRECTION FACTORS - OTHER AIRFLOWS (multiply or add as indicated)		
			72	74	76	78	80					
85	59	20.0	16.9	18.3	19.7	20.4*	20.9*	1.09	47.1	AIRFLOW 700 900 TOTAL CAP. X0.99 X1.01 SENS. CAP. X0.94 X1.06 COMPR. KW X1.00 X1.00 A.D.P. -1.3 +1.0		
	63	21.5	14.1	15.5	16.9	18.4	19.8	1.11	51.1			
	67	23.0	11.1	12.5	13.9	15.3	16.7	1.13	55.3			
	71	24.6	7.9	9.3	10.7	12.1	13.6	1.15	59.6			
90	59	18.8	16.4	17.8	18.9*	19.4*	19.9*	1.15	47.9			
	63	20.2	13.6	15.0	16.4	17.9	19.3	1.17	51.8			
	67	21.7	10.6	12.0	13.4	14.8	16.2	1.19	56.0			
	71	23.2	7.5	8.9	10.3	11.7	13.1	1.22	60.3			
95	59	17.5	15.9	17.3	17.9*	18.4*	18.9*	1.21	48.7			
	63	18.9	13.1	14.5	15.9	17.3	18.8	1.23	52.6			
	67	20.4	10.1	11.5	12.9	14.3	15.7	1.26	56.8			
	71	21.9	7.0	8.4	9.8	11.2	12.6	1.29	61.1			
100	59	16.3	15.3	16.5*	16.9*	17.4*	17.9*	1.27	49.6			
	63	17.7	12.6	14.0	15.4	16.8	17.9*	1.30	53.4			
	67	19.1	9.6	11.0	12.4	13.8	15.2	1.33	57.6			
	71	20.5	6.5	7.9	9.4	10.8	12.2	1.36	61.8			
105	59	15.1	14.8	15.5*	15.9*	16.4*	16.9*	1.33	50.4			
	63	16.4	12.1	13.5	14.9	16.4*	16.9*	1.36	54.2			
	67	17.8	9.1	10.5	11.9	13.4	14.8	1.39	58.3			
	71	19.2	6.1	7.5	8.9	10.3	11.7	1.42	62.5			
115	59	12.6	13.0*	13.5*	13.9*	14.4*	14.8*	1.45	52.0			
	63	13.8	11.1	12.5	13.9*	14.4*	14.8*	1.48	55.8			
	67	15.2	8.2	9.6	11.0	12.4	13.8	1.52	59.9			
	71	16.5	5.1	6.6	8.0	9.4	10.8	1.56	64.0			



Performance Data Cooling

YCZ050F—A AT 1600 CFM (CAPACITIES ARE NET IN BTUH/1000-INDOOR FAN HEAT DEDUCTED)

O.D. D.B.	I.D. W.B.	TOTAL CAP.	SENS. CAP. AT ENTERING D.B. TEMP.					TOTAL KW	APP. DEW PT.	CORRECTION FACTORS - OTHER AIRFLOWS (multiply or add as indicated)
			72	74	76	78	80			
85	59	46.2	36.4	39.4	42.3	45.3	47.1*	3.93	45.2	AIRFLOW 1400 1600 TOTAL CAP. X0.98 X1.00 SENS. CAP. X0.94 X1.00 COMPR. KW X0.99 X1.00 A.D.P. -1.4 0.0 VALUES AT ARI RATING CONDITIONS TOTAL NET CAPACITY = 51000 BTUH AIRFLOW = 1600 CFM APP. DEW PT. = 54.0 DEG. F COMPRESSOR POWER = 3720 WATTS I.D. FAN POWER = 310 WATTS O.D. FAN POWER = 400 WATTS * DRY COIL CONDITION (TOTAL CAPACITY = SENSIBLE CAPACITY) TOTAL CAPACITY, COMP. KW AND APP. DEW PT. ARE VALID ONLY FOR WET COIL ALL TEMPERATURES IN DEGREES F.
	63	49.8	30.7	33.6	36.6	39.5	42.5	4.00	49.1	
	67	53.7	24.4	27.3	30.3	33.2	36.2	4.08	53.3	
	71	57.6	17.9	20.9	23.8	26.8	29.7	4.16	57.5	
90	59	45.1	35.9	38.9	41.8	44.8	46.2*	4.10	45.6	
	63	48.6	30.2	33.1	36.1	39.1	42.0	4.18	49.5	
	67	52.3	23.9	26.8	29.8	32.7	35.7	4.26	53.6	
	71	56.2	17.4	20.4	23.3	26.3	29.2	4.34	57.9	
95	59	44.0	35.5	38.4	41.4	44.2*	45.3*	4.28	45.9	
	63	47.4	29.7	32.7	35.6	38.6	41.5	4.35	49.8	
	67	51.0	23.4	26.3	29.3	32.2	35.2	4.43	54.0	
	71	54.7	16.9	19.9	22.8	25.8	28.7	4.51	58.3	
100	59	42.7	35.0	37.9	40.9	43.2*	44.3*	4.46	46.3	
	63	46.1	29.2	32.1	35.1	38.1	41.0	4.53	50.2	
	67	49.5	22.8	25.8	28.8	31.7	34.7	4.60	54.4	
	71	53.1	16.4	19.3	22.3	25.2	28.2	4.68	58.7	
105	59	41.5	34.5	37.4	40.4	42.2*	43.3*	4.65	46.7	
	63	44.7	28.7	31.6	34.6	37.5	40.5	4.71	50.6	
	67	48.1	22.3	25.3	28.2	31.2	34.1	4.78	54.8	
	71	51.5	15.8	18.8	21.8	24.7	27.7	4.85	59.1	
115	59	39.1	33.4	36.4	39.3*	40.2*	41.2*	5.03	47.4	
	63	42.0	27.6	30.6	33.5	36.5	39.4	5.08	51.3	
	67	45.2	21.3	24.2	27.2	30.1	33.1	5.13	55.5	
	71	48.4	14.8	17.7	20.7	23.6	26.6	5.18	59.8	

YCZ050F—A AT 1000 CFM (CAPACITIES ARE NET IN BTUH/1000-INDOOR FAN HEAT DEDUCTED)

O.D. D.B.	I.D. W.B.	TOTAL CAP.	SENS. CAP. AT ENTERING D.B. TEMP.					TOTAL KW	APP. DEW PT.	CORRECTION FACTORS - OTHER AIRFLOWS (multiply or add as indicated)
			72	74	76	78	80			
85	59	25.6	20.1	21.8	23.6	25.4	26.2*	1.81	45.2	AIRFLOW 875 1000 TOTAL CAP. X0.98 X1.00 SENS. CAP. X0.93 X1.00 COMPR. KW X1.00 X1.00 A.D.P. -1.2 0.0 VALUES AT ARI RATING CONDITIONS TOTAL NET CAPACITY = 28000 BTUH AIRFLOW = 1000 CFM APP. DEW PT. = 54.0 DEG. F COMPRESSOR POWER = 1580 WATTS I.D. FAN POWER = 120 WATTS O.D. FAN POWER = 300 WATTS * DRY COIL CONDITION (TOTAL CAPACITY = SENSIBLE CAPACITY) TOTAL CAPACITY, COMP. KW AND APP. DEW PT. ARE VALID ONLY FOR WET COIL ALL TEMPERATURES IN DEGREES F.
	63	27.6	16.6	18.4	20.2	21.9	23.7	1.82	49.1	
	67	29.6	12.9	14.6	16.4	18.1	19.9	1.83	53.4	
	71	31.7	9.0	10.8	12.6	14.3	16.1	1.84	57.7	
90	59	25.0	19.9	21.6	23.4	25.1*	25.7*	1.91	45.5	
	63	26.9	16.4	18.2	19.9	21.7	23.4	1.91	49.4	
	67	28.8	12.6	14.4	16.1	17.9	19.6	1.92	53.7	
	71	30.8	8.8	10.5	12.3	14.0	15.8	1.92	58.0	
95	59	24.4	19.7	21.4	23.2	24.6*	25.2*	2.00	45.7	
	63	26.2	16.2	17.9	19.7	21.4	23.2	2.00	49.7	
	67	28.0	12.3	14.1	15.9	17.6	19.4	2.00	54.0	
	71	29.9	8.5	10.2	12.0	13.8	15.5	2.00	58.4	
100	59	23.8	19.4	21.2	22.9	24.1*	24.7*	2.10	46.0	
	63	25.4	15.9	17.6	19.4	21.2	22.9	2.10	50.0	
	67	27.1	12.1	13.8	15.6	17.3	19.1	2.09	54.3	
	71	28.9	8.2	9.9	11.7	13.5	15.2	2.08	58.7	
105	59	23.1	19.2	20.9	22.7	23.5*	24.1*	2.21	46.3	
	63	24.7	15.6	17.4	19.1	20.9	22.7	2.19	50.3	
	67	26.3	11.8	13.5	15.3	17.1	18.8	2.18	54.7	
	71	28.0	7.9	9.7	11.4	13.2	14.9	2.16	59.0	
115	59	21.7	18.7	20.4	21.9*	22.4*	22.9*	2.43	46.9	
	63	23.1	15.1	16.9	18.6	20.4	22.1	2.39	51.0	
	67	24.6	11.2	13.0	14.8	16.5	18.3	2.35	55.3	
	71	26.1	7.3	9.1	10.9	12.6	14.4	2.31	59.7	



Performance Data Cooling

YCZ060F—B AT 2000 CFM (CAPACITIES ARE NET IN BTUH/1000-INDOOR FAN HEAT DEDUCTED)

O.D. D.B.	I.D. W.B.	TOTAL CAP.	SENS. CAP. AT ENTERING D.B. TEMP.					COMPR. KW	APP.DEW PT.	CORRECTION FACTORS - OTHER AIRFLOWS (multiply or add as indicated)		
			72	74	76	78	80					
85	59	54.8	43.7	47.2	50.7	54.3	55.8*	3.91	46.2	AIRFLOW 1750 2250 TOTAL CAP. X0.99 X1.01 SENS. CAP. X0.94 X1.05 COMPR. KW X1.00 X1.00 A.D.P. -1.5 +1.2		
	63	58.5	36.6	40.1	43.6	47.1	50.7	3.98	50.2			
	67	62.5	28.8	32.3	35.8	39.4	42.9	4.05	54.5			
	71	66.4	20.8	24.3	27.8	31.4	34.9	4.12	58.8			
90	59	53.2	43.0	46.5	50.0	53.3*	54.5*	4.07	46.6	VALUES AT ARI RATING CONDITIONS TOTAL NET CAPACITY = 59000 BTUH AIRFLOW = 2000 CFM APP. DEW PT. = 55.3 DEG. F COMPRESSOR POWER = 4420 WATTS I.D. FAN POWER = 540 WATTS O.D. FAN POWER = 400 WATTS * DRY COIL CONDITION (TOTAL CAPACITY = SENSIBLE CAPACITY) TOTAL CAPACITY, COMP. KW AND APP. DEW PT. ARE VALID ONLY FOR WET COIL ALL TEMPERATURES IN DEGREES F.		
	63	56.8	35.9	39.4	42.9	46.5	50.0	4.15	50.6			
	67	60.7	28.1	31.6	35.2	38.7	42.2	4.24	54.9			
	71	64.6	20.2	23.7	27.2	30.7	34.3	4.32	59.2			
95	59	51.6	42.3	45.8	49.4	52.0*	53.2*	4.23	47.0			
	63	55.2	35.2	38.7	42.3	45.8	49.3	4.32	51.0			
	67	59.0	27.5	31.0	34.5	38.0	41.6	4.42	55.3			
	71	62.8	19.5	23.0	26.6	30.1	33.6	4.52	59.7			
100	59	50.0	41.6	45.1	48.7	50.8*	51.9*	4.39	47.5			
	63	53.5	34.5	38.1	41.6	45.1	48.7	4.49	51.5			
	67	57.3	26.8	30.3	33.9	37.4	40.9	4.60	55.7			
	71	61.0	18.9	22.4	25.9	29.5	33.0	4.72	60.1			
105	59	48.4	40.9	44.5	48.0	49.5*	50.6*	4.55	47.9			
	63	51.9	33.9	37.4	40.9	44.5	48.0	4.66	51.9			
	67	55.5	26.1	29.7	33.2	36.7	40.3	4.79	56.1			
	71	59.2	18.2	21.8	25.3	28.8	32.4	4.92	60.5			
115	59	45.3	39.6	43.1	45.8*	46.9*	48.0*	4.86	48.8			
	63	48.6	32.5	36.1	39.6	43.1	46.6	5.01	52.8			
	67	52.1	24.8	28.4	31.9	35.4	39.0	5.16	57.0			
	71	55.6	17.0	20.5	24.0	27.6	31.1	5.31	61.3			

YCZ060F—B AT 1100 CFM (CAPACITIES ARE NET IN BTUH/1000-INDOOR FAN HEAT DEDUCTED)

O.D. D.B.	I.D. W.B.	TOTAL CAP.	SENS. CAP. AT ENTERING D.B. TEMP.					COMPR. KW	APP.DEW PT.	CORRECTION FACTORS - OTHER AIRFLOWS (multiply or add as indicated)		
			72	74	76	78	80					
85	59	28.1	23.5	25.4	27.4	28.5*	29.2*	1.57	47.5	AIRFLOW 975 1250 TOTAL CAP. X0.99 X1.01 SENS. CAP. X0.95 X1.06 COMPR. KW X1.00 X1.00 A.D.P. -1.2 +1.1		
	63	30.1	19.7	21.6	23.5	25.5	27.4	1.59	51.4			
	67	32.3	15.4	17.4	19.3	21.3	23.2	1.62	55.6			
	71	34.4	11.1	13.0	15.0	16.9	18.9	1.64	60.0			
90	59	26.9	23.0	25.0	26.9	27.6*	28.2*	1.68	48.0			
	63	28.9	19.2	21.1	23.1	25.0	26.9	1.70	52.0			
	67	31.0	15.0	16.9	18.9	20.8	22.7	1.73	56.2			
	71	33.1	10.7	12.6	14.5	16.5	18.4	1.76	60.5			
95	59	25.8	22.5	24.5	26.0*	26.7*	27.3*	1.78	48.6			
	63	27.7	18.7	20.6	22.6	24.5	26.5	1.81	52.5			
	67	29.8	14.5	16.5	18.4	20.3	22.3	1.84	56.7			
	71	31.9	10.2	12.2	14.1	16.0	18.0	1.87	61.0			
100	59	24.7	22.0	24.0	25.1*	25.7*	26.4*	1.88	49.1			
	63	26.6	18.2	20.2	22.1	24.1	26.0	1.91	53.0			
	67	28.6	14.1	16.0	17.9	19.9	21.8	1.95	57.2			
	71	30.6	9.8	11.7	13.7	15.6	17.5	1.99	61.5			
105	59	23.5	21.6	23.5*	24.2*	24.8*	25.4*	1.98	49.7			
	63	25.4	17.8	19.7	21.6	23.6	25.4*	2.02	53.6			
	67	27.3	13.6	15.5	17.5	19.4	21.4	2.06	57.8			
	71	29.3	9.3	11.3	13.2	15.2	17.1	2.10	62.0			
115	59	21.2	20.6	21.7*	22.3*	23.0*	23.6*	2.19	50.8			
	63	23.0	16.8	18.8	20.7	22.6	23.6*	2.24	54.7			
	67	24.9	12.7	14.6	16.6	18.5	20.4	2.29	58.8			
	71	26.8	8.5	10.4	12.3	14.3	16.2	2.34	63.1			



Performance Data Heating

TEMPERATURE RISE

	YCZ036-M		YCZ050-H		YCZ060-M	
	1000 CFM NOM.		1600 CFM NOM.		2000 CFM NOM	
	1ST STAGE HT INPUT	2ND STAGE INPUT	1ST STAGE HT INPUT	2ND STAGE INPUT	1ST STAGE HT INPUT	2ND STAGE INPUT
	56,000	72,000	90,000	120,000	90,000	120,000
550	-	-	-	-	-	-
600	-	-	-	-	-	-
650	-	-	-	-	-	-
700	-	-	-	-	-	-
750	-	-	-	-	-	-
800	-	-	-	-	-	-
850	-	-	-	-	-	-
900	-	-	-	-	-	-
950	-	-	-	-	-	-
1000	41.5	53.3	-	-	-	-
1050	39.5	50.8	-	-	-	-
1100	37.7	48.5	-	-	-	-
1150	36.1	46.4	-	-	-	-
1200	34.6	44.4	-	-	-	-
1250	33.1	42.7	-	-	55.3	-
1300	31.9	41.0	51.3	-	53.2	-
1350	30.7	39.5	49.4	65.8	51.2	-
1400	29.6	38.1	47.6	63.6	49.4	-
1450	-	-	46.0	61.3	47.7	-
1500	-	-	44.4	59.3	46.1	-
1550	-	-	43.0	57.3	44.6	-
1600	-	-	41.7	55.6	43.2	-
1650	-	-	40.4	53.9	41.9	-
1700	-	-	39.2	52.3	40.7	-
1750	-	-	38.1	50.8	39.5	-
1800	-	-	37.0	49.4	38.4	51.2
1850	-	-	36.0	48.0	37.4	49.8
1900	-	-	35.1	46.8	-	48.5
1950	-	-	-	-	-	47.3
2000	-	-	-	-	-	46.1
2050	-	-	-	-	-	44.98
2100	-	-	-	-	-	43.9
2150	-	-	-	-	-	42.9
2200	-	-	-	-	-	41.9
2150	-	-	-	-	-	40.9
2200	-	-	-	-	-	-
2250	-	-	-	-	-	-



Performance Data Indoor Fan

INDOOR BLOWER PERFORMANCE YCZ,WCZ036F

AIRFLOW SETTING	DIPSWITCH SETTINGS				SPEED	EXTERNAL STATIC PRESSURE - IN. W.G.																	
						.20 ^①			.30 ^①			.50 ^①			.70 ^①			.90 ^①			1.0 ^①		
						CFM	PWR WATTS	BHP	CFM	PWR WATTS	BHP	CFM	PWR WATTS	BHP	CFM	PWR WATTS	BHP	CFM	PWR WATTS	BHP	CFM	PWR WATTS	BHP
350 CFM/TON	OFF	OFF	OFF	ON	HI	1040	180	.17	1140	210	.20	1050	250	.24	1040	310	.31	1030	360	.35	1020	380	.37
					LO	690	80	.07	680	94	.09	680	130	.12	670	170	.17	650	190	.19	640	210	.21
400 CFM/TON ^②	OFF	OFF	OFF	OFF	HI	1190	270	.25	1190	310	.29	1200	380	.36	1190	460	.46	1180	540	.53	1160	570	.56
					LO	790	120	.10	780	140	.13	780	200	.19	760	260	.25	740	290	.29	730	320	.32
450 CFM/TON	OFF	OFF	ON	OFF	HI	1340	380	.35	1340	440	.41	1350	540	.52	1340	650	.65	1330	770	.75	-----	-----	-----
					LO	890	170	.15	880	200	.19	890	280	.27	860	370	.36	830	410	.40	-----	-----	-----

B665606 REV. 0

① WET COIL, NO FILTERS

② FACTORY SETTINGS

INDOOR BLOWER PERFORMANCE YCZ050F

AIRFLOW SETTING	DIPSWITCH SETTINGS				SPEED	EXTERNAL STATIC PRESSURE - IN. W.G.																	
						.20 ^①			.30 ^①			.50 ^①			.70 ^①			.90 ^①			1.0 ^①		
						CFM	PWR WATTS	BHP	CFM	PWR WATTS	BHP	CFM	PWR WATTS	BHP	CFM	PWR WATTS	BHP	CFM	PWR WATTS	BHP	CFM	PWR WATTS	BHP
350 CFM/TON	ON	OFF	OFF	ON	HI	1303	211	.19	1329	250	.24	1366	326	.33	1383	417	.42	1100	418	.43	-----	-----	-----
					LO	835	100	.08	829	134	.13	809	175	.17	790	240	.24	743	276	.28	-----	-----	-----
400 CFM/TON ^②	OFF	ON	OFF	OFF	HI	1483	284	.28	1524	333	.33	1543	404	.41	1569	505	.51	1197	451	.47	-----	-----	-----
					LO	946	123	.12	957	150	.14	940	212	.21	911	280	.29	865	323	.34	-----	-----	-----
450 CFM/TON	ON	ON	ON	OFF	HI	1654	364	.36	1709	424	.42	1754	530	.53	1793	639	.64	1285	494	.51	-----	-----	-----
					LO	1064	146	.14	1065	171	.17	1081	251	.25	1076	319	.33	969	358	.37	-----	-----	-----

B668822 REV. 0

② FACTORY SETTINGS

① WET COIL, NO FILTERS

INDOOR BLOWER PERFORMANCE WCZ, YCZ060F

AIRFLOW SETTING	DIPSWITCH SETTINGS				SPEED	EXTERNAL STATIC PRESSURE - IN. W.G.																	
						.20 ^①			.30 ^①			.50 ^①			.70 ^①			.90 ^①			1.00 ^①		
						CFM	PWR WATTS	BHP	CFM	PWR WATTS	BHP	CFM	PWR WATTS	BHP	CFM	PWR WATTS	BHP	CFM	PWR WATTS	BHP	CFM	PWR WATTS	BHP
350 CFM/TON	OFF	OFF	OFF	ON	HI	1760	380	.38	1750	420	.40	1720	490	.48	1710	560	.54	1700	630	.62	1700	680	.66
					LO	1000	106	.01	970	116	.11	960	149	.14	940	187	.18	900	217	.22	-----	-----	-----
400 CFM/TON ^②	OFF	OFF	OFF	OFF	HI	2040	540	.54	2020	590	.57	2010	660	.64	2010	750	.71	2005	830	.81	2000	870	.85
					LO	1143	158	.14	1113	173	.16	1094	223	.21	1073	279	.27	1026	324	.32	-----	-----	-----
450 CFM/TON	OFF	OFF	ON	OFF	HI	2260	750	.70	2250	780	.72	2240	830	.78	2240	980	.89	2210	1070	1.02	-----	-----	-----
					LO	1290	225	.21	1250	246	.23	1230	318	.31	1210	397	.39	1150	461	.46	-----	-----	-----

B665605 REV. 0

① WET COIL, NO FILTER

② FACTORY SETTING

Sequence Of Operation

Operation of the unit heating or cooling cycles is controlled by the setting of the system switch on the room thermostat. Once the system switch is placed either in the "HEAT" or "COOL" position, unit operation is automatic. A fan switch on the thermostat also provides for its continuous operation of the evaporator fan when desired. The fan switch "ON" position provides continuous operation while the "AUTO" position provides operation during the heating or cooling cycles.

HEATING CYCLE

Thermostat call for heat (2-stage thermostat)

Call for 1st stage only:

(R) and (W1) thermostat contacts close signaling the control module (IGN) to run its self-check routine. After the control has verified that the pressure switch (PS) contacts are open, the limit switch (TCO) contacts are closed, and the flame rollout (FL) switch is closed, the induced draft blower (CBM) will be energized on high speed for approximately 5 seconds.

After the induced draft blower (CBM) has come up to speed, the control will verify that the pressure switch (PS) contacts are closed and switch the induced draft blower to low speed for 10-second prepurge. The gas valve (GV) is energized in the first stage to permit gas flow and the spark ignitor (IP) is energized. The flame detector (FD) confirms that ignition has been achieved within the 7 second trial period.

As the flame detector confirms that ignition has been achieved the delay to indoor fan on period begins timing and after approximately 45 seconds, the indoor blower motor (IDM) will be energized at low speed and will continue to run during the heating cycle.

Call for 2nd stage after 1st stage:

(R) and (W2) thermostat contacts close signaling a call for second stage heat. The induced draft motor (CBM) is energized on high speed and the gas valve on second stage. After approximately 30 seconds the control energizes the indoor blower on high speed.

2nd stage satisfied, 1st stage still called:

(R) and (W2) opens, the induced draft blower is reduced to low speed, the gas valve is reduced to first stage. After approx. 30 seconds the indoor blower motor is reduced to low speed.

1st stage satisfied:

(R) and (W1) opens, the gas valve (GV) will close. The induced draft blower (CBM) will be de-energized after approximately 5 seconds postpurge. The indoor blower motor (IDM) will continue to run for the fan off period (field selectable 60 or 90 seconds [by dip switch]), then will be de-energized by the control module.

Thermostat satisfied:

(R) and (W1/W2) (jumpered) contacts open signaling the control module to close the gas valve and de-energize the induced draft blower after approximately 5 second postpurge. The I.D. blower motor will continue to operate at the current speed for 60 or 90 seconds after the flames are extinguished.

SAFETY SEQUENCES

This product is equipped with safety devices to protect against abnormal conditions.

The temperature limit switch (TCO) is located in the gas compartment on the vestibule panel above the burner assembly. This automatic reset device protects against excessive leaving air temperature. If this device opens, the gas valve is immediately closed and will not permit operation until the limit switch closes.

The rollout switch (FS) is located in the gas compartment near the inlet of the burners. This is a single use device designed to protect against any form of flame rollout. If this device is opened the gas valve is immediately de-energized and the control (IGN) will lockout the system.

The rollout switch (FS) must be replaced before operation is allowed to continue.

The pressure switch (PS) is located in the upper right side of the gas compartment. This automatic device assures adequate combustion air pressure. If pressure against the induced draft blower outlet becomes excessive, the pressure switch will react and shut off the gas valve, until acceptable combustion pressure is again available.

If the control (IGN) does not sense flame within the first trial for ignition period. The gas valve will be de-energized. The control (IGN) will initiate a 60 seconds interpurge. Following the interpurge, on the second trial the gas valve will be energized on second stage (high heat input). If the flame is sensed within 10 seconds after the second try and only a call for first stage exists, the gas valve will be reduced to first stage. If the second try is not successful. The control will start another 60 second interpurge. After the interpurge, a third attempt will be tried. The gas valve will be energized on second stage (high heat input). If the flame is sensed within 10 seconds after the third try and only a call for first stage exists, the gas valve will be reduced to first stage. If the third try is not successful, the control will lock out.

If loss of flame occurs during a heating cycle, the control (IGN) will close the gas valve. The control will then recycle the ignition sequence, then if ignition is not achieved, it will shut off the gas valve and lock out the system.

If control lock out occurs, the control (IGN) will retry a complete ignition sequence in 2 hours.

The control (IGN) can be reset by removing power to the unit or by turning the thermostat from "on" to "off" for approximately three seconds, then back "on."

COOLING CYCLE

Thermostat call for cool (2-stage thermostat)

Call for 1st stage only:

With the room thermostat system switch in the "COOLING" position and the fan switch in the "AUTO" position, the Y1 thermostat contact closes to the micro board (*the board will wait 3 seconds to check if the Y2 may also be calling*) the micro will energize (CC1) and the outdoor fan relay for low speed and the G thermostat contact to G-IGN and to G1 on the ICMC is energized. (*The status light is flashing and the Y1 light is on.*)

The energized compressor contactor (CC1) completes the circuit to the compressor (CPR1). If the compressor safety controls are closed, the compressor (CPR1) will operate with the outdoor fan motor (ODM) on low speed. The indoor fan motor (IDM) will operate on low speed. The thermostat will continue to cycle the compressor and fans to maintain the desired temperature.

With the thermostat fan switch in the "ON" position, the G thermostat contact is closed to G1 on the ICMC board and the indoor fan motor (IDM) will continue to run on low speed regardless of compressor and condenser fan operation.

Call for 2nd stage after 1st stage:

The Y2 thermostat contact closes to the control board. For 1 minute both compressors are off (all lights are flashing for 1 minute), then the board will energize the (CC2) compressor contactor, and the outdoor fan relay for high speed, then the board (YCZ050 ONLY - will energize the (CC1) and 1 second later the (CC2) compressor contactors) and the indoor fan high to the Y on the ICMC board is energized for indoor high speed fan operation. (*The status light is flashing and the Y1 and Y2 lights are on.*)



Sequence Of Operation

2nd stage satisfied, 1st stage still called: (YCZ036,060F ONLY)

The Y2 thermostat contact opens to the control board. For 1 minute both compressors are off (*the status and Y1 light are flashing for 1 minute*), then the board will energize (CC1) low compressor contactor, and the outdoor fan relay for low speed and indoor fan for low speed. (*The status light is flashing and the Y1 light is on.*)

2nd stage satisfied, 1st stage still called: (YCZ050 ONLY)

The Y2 thermostat contact opens to the control board. The board will de-energize (CC2) second compressor contactor, and energize the outdoor fan relay for low speed and indoor fan for low speed. (*The status light is flashing and the Y1 light is on.*)

ICM FAN MOTOR ADJUSTMENTS

If the airflow needs to be increased or decreased, see the Indoor Blower Performance Table below. Information on changing the dip switch settings for speed control of the blower motor is in this table.

Blower speed changes are made on the ICM Fan Control mounted in the control box. The ICM Fan Control controls the variable speed motor.

There is a bank of 8 dip switches (See Figure below), located at the lower right side of the board. The dip switches work in pairs to select the cooling/heat airflow (CFM/TON), and Fan off-delay options.

INDOOR BLOWER TIMING

The ICM Fan Control controls the variable speed indoor blower. The FAN-OFF period is set on the ICM Fan Control board by dip switches #5 and #6. The delay settings of the blower are as follows:

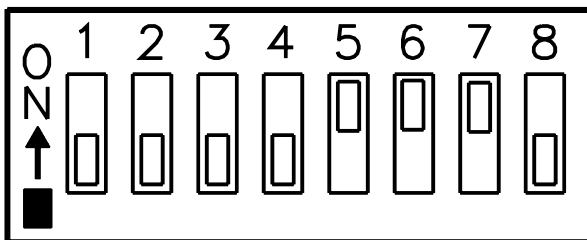
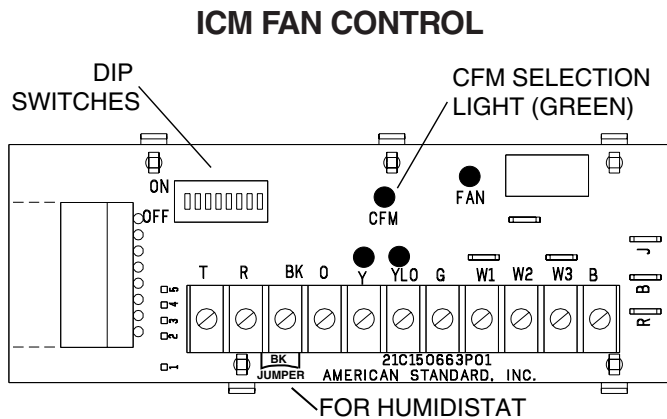

DIP SWITCHES (TYPICAL SETTINGS)

COOLING OFF - DELAY OPTIONS

SWITCH SETTINGS		SELECTION	NOMINAL AIRFLOW
5 - OFF	6 - OFF	NONE	SAME
5 - ON	6 - OFF	1.5 MINUTES	100% *
5 - OFF	6 - ON	3 MINUTES	50%
5 - ON	6 - ON	ENHANCED**	50 - 100%

* - This setting is equivalent to the BAY24X045 relay benefit

** - This ENHANCED MODE selection provides a ramping up and ramping down of the blower speed to provide improved comfort, quietness, and potential energy savings. The graph shows the ramping process.

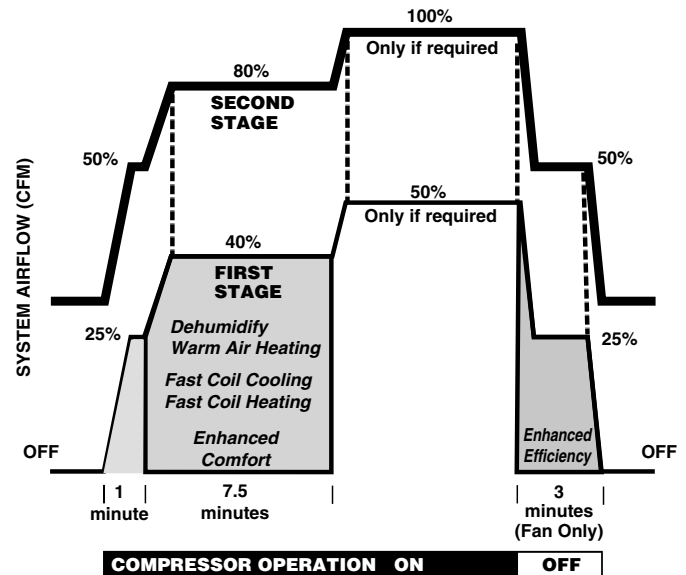

Optional Equipment

25% Manual Fresh Air Kit

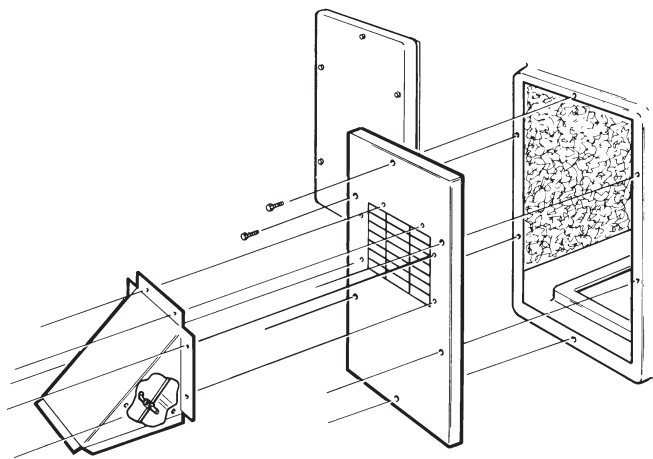

Filter Frame

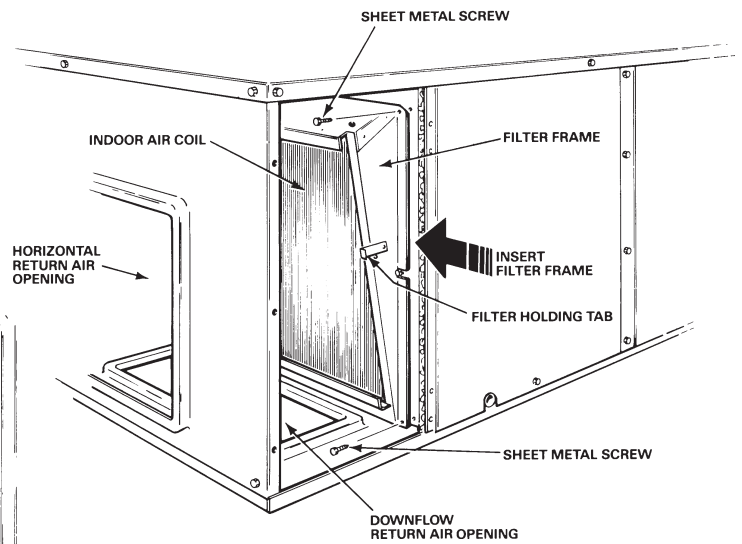

BAYECONO73A Horizontal Economizer and Rain Hood

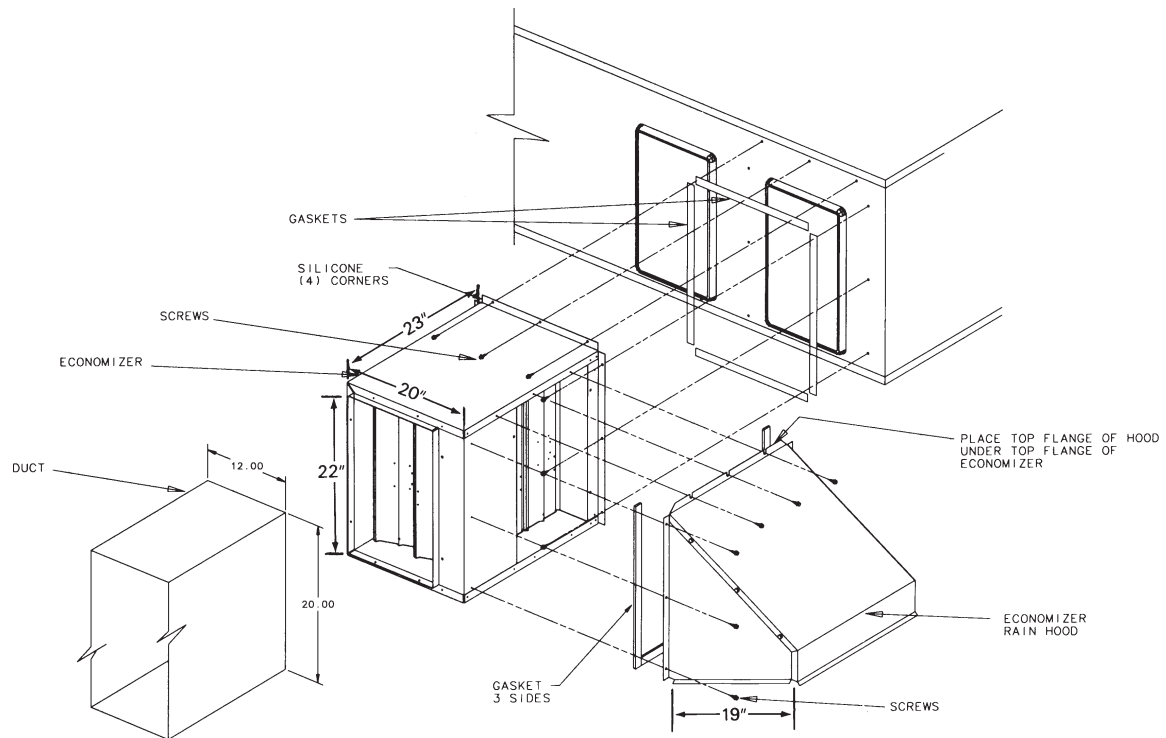

From Dwg. 21D662056 Rev. 0

Optional Equipment

Economizer and Rain Hood (Downflow Applications)

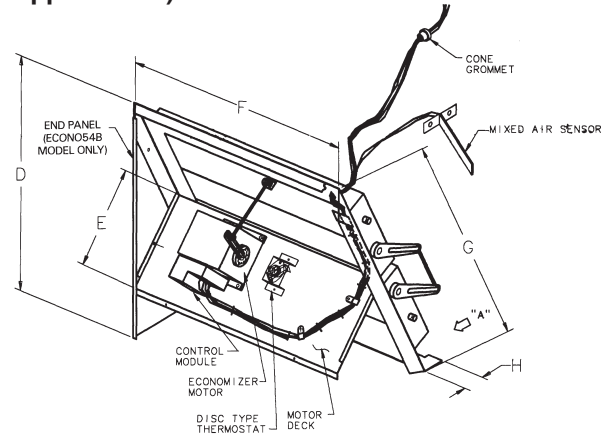
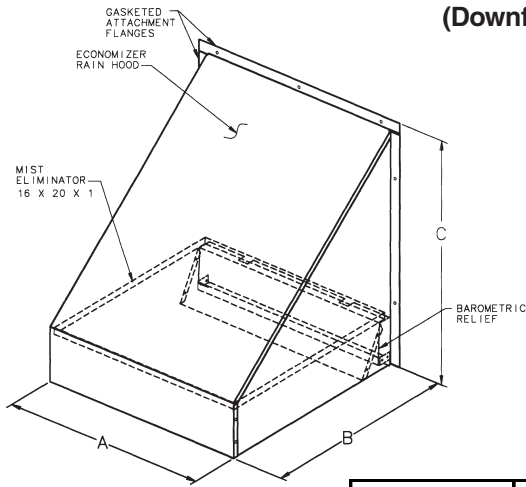

ECONOMIZER MODEL	APPLICATION MODELS	A	B	C	D	E	F	G	H
BAYECON054B	YCZ036F	20	16-5/8	23-1/2	22-9/16	8-5/8	22-1/4	25-1/8	1-1/2
BAYECON055B	YCZ050F YCZ060F	20	21	26	OMIT	12-1/8	26-1/8	32-1/8	1-3/4

Economizer Pressure Drop — (Return Air Restriction 0% Outdoor Air)

AIRFLOW (CFM)	BAYECON054B (in. H ₂ O)	BAYECON055B in. (H ₂ O)	BAYECON073A (in. H ₂ O)
600	.010		.010
800	.020		.015
1000	.050		.020
1200	.090	.040	.025
1400	.140	.050	.030
1600		.075	.035
1800		.100	.045
2000		.130	.055
2200		.150	.075
2400		.190	.100

From Dwg. 21A730983 Rev. 1

Controls

Field Installed Control Options

Thermostats

Two stages heating/cooling or one stage heating/cooling thermostats are available in either manual or automatic changeover.

Programmable Electronic Night Setback Thermostat

Heating setback and cooling setup with 7-day, 5-1-1 programming capability. Available in 2 heating/cooling or 1 heating/cooling versions with automatic changeover.

Economizer Controls

The standard equipment offering is a fixed dry bulb changeover control. In addition to the standard offering, there are two other field installed control accessories.

Enthalpy Control

Replaces the dry bulb control with a solid state dry bulb and wet bulb changeover controller which has a fully adjustable set point. Enthalpy control offers a higher level of

energy savings potential than the standard dry bulb control due to the additional wet bulb sensing capability.

Differential Enthalpy

Replaces the standard dry bulb control with two enthalpy sensors that compare total heat content of the indoor air and outdoor air to determine the most efficient entering air source. This control option offers the highest level of energy efficiency available.

Field Wiring

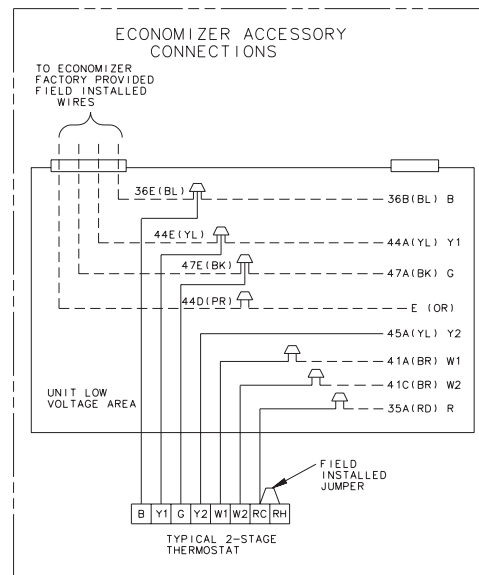
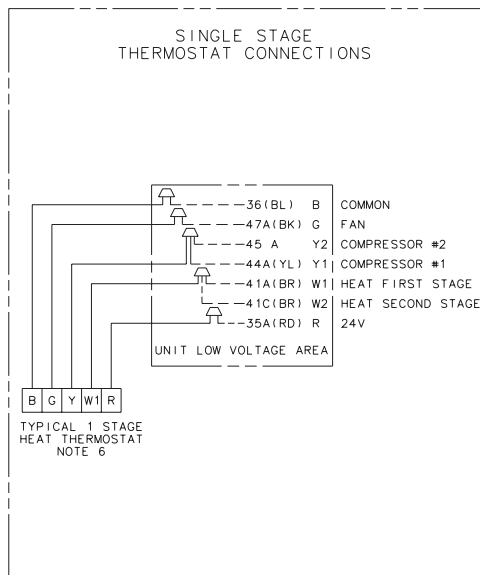
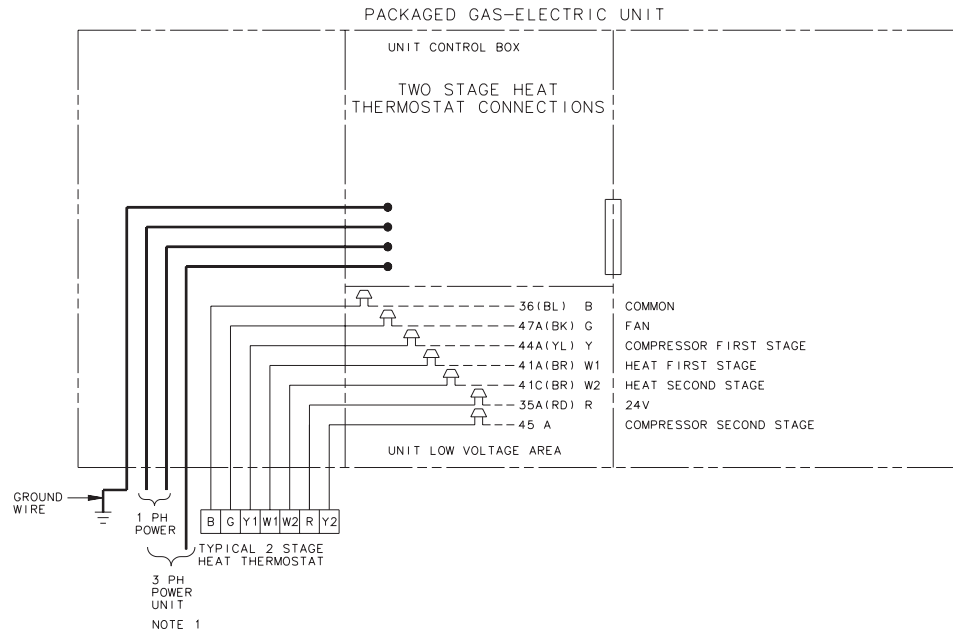

NOTES:

1. FUSED DISCONNECT SIZE, POWER WIRING AND GROUNDING OF EQUIPMENT MUST COMPLY WITH CODES.
2. BE SURE POWER SUPPLY AGREES WITH EQUIPMENT AND HEATER NAMEPLATE.
3. LOW VOLTAGE WIRING TO BE 18 AWG MINIMUM CONDUCTOR.
4. SEE UNIT DIAGRAM FOR ELECTRICAL CONNECTION DETAILS.
5. THE THERMOSTAT ON THE GAS/ELECTRIC UNIT MUST PROVIDE A 'G' SIGNAL IN THE COOLING MODE ONLY. DURING THE HEATING MODE THE FAN WILL BE ENERGIZED BY THE SYSTEM.
6. FOR SINGLE STAGE THERMOSTATS JUMPER W1 AND W2 TOGETHER. SECOND STAGE HEAT WILL BEGIN 10 MINUTES AFTER FIRST STAGE.

INTER-COMPONENT WIRING

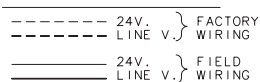

WIRE COLOR DESIGNATION			
ABBR	COLOR	ABBR	COLOR
BK	BLACK	PR	PURPLE
BL	BLUE	RD	RED
BR	BROWN	WH	WHITE
GR	GREEN	YL	YELLOW
OR	ORANGE		

From Dwg. 21C757231

Typical Wiring

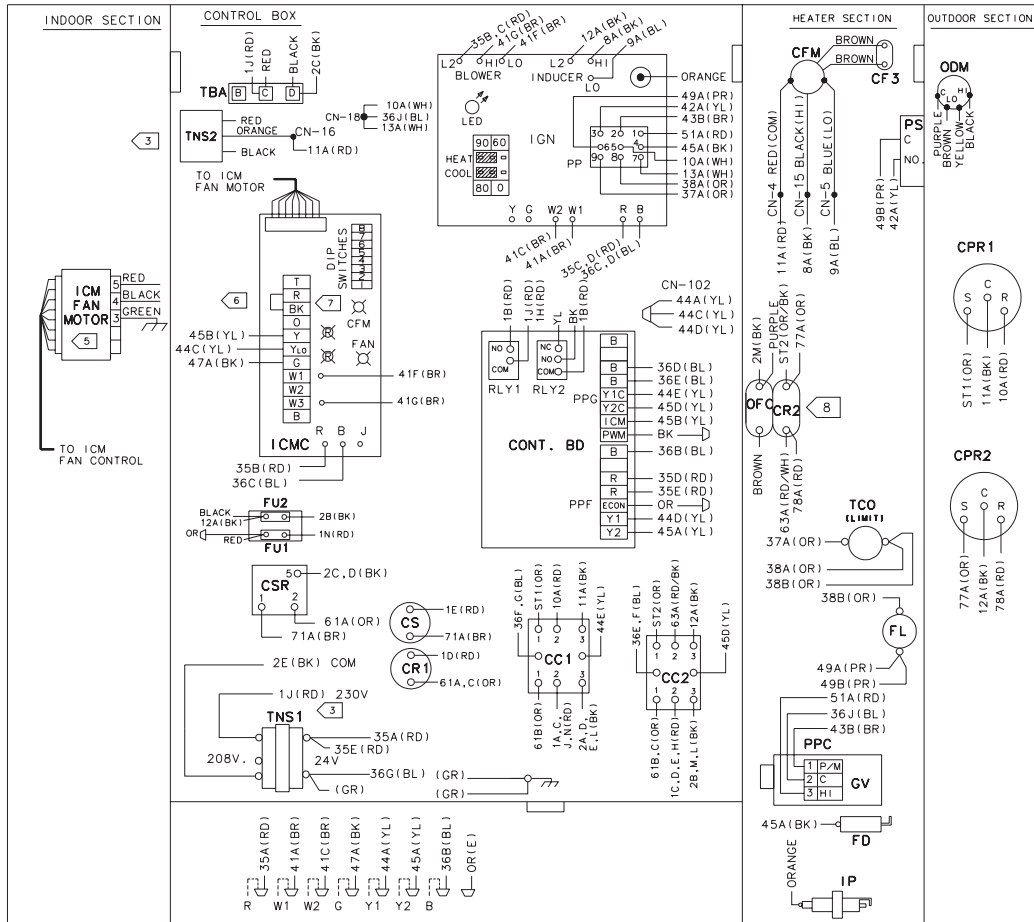

ICMC DIP SWITCH SETTINGS

DIP SWITCH SETTINGS			COOLING	NOMINAL AIRFLOW
SW 1	SW 2	SW 3	ON	350 CFM/TON
OFF	OFF	OFF	ON	1750 CFM
OFF	OFF	OFF	OFF	400 CFM/TON
OFF	OFF	OFF	ON	2000 CFM **
OFF	OFF	ON	OFF	450 CFM/TON
OFF	OFF	ON	ON	2250 CFM
			FAN OFF-DELAY OPTIONS	
SW 5	SW 6		NONE	NOMINAL **
OFF	OFF		ON	90 SECONDS
ON	OFF		ON	100 * NOMINAL
OFF	ON		ON	180 SECONDS
ON	ON		ON	50 * NOMINAL
ON	ON		ON	ENHANCED

** FACTORY SETTING.
 AT CONTINUOUS FAN SETTING ("G" ONLY) AIRFLOW VALUES ARE APPROXIMATELY 65% OF LISTED VALUE.
 NOTE: UNIT POWER MUST BE OFF WHEN DIP SWITCHES ARE RESET.

NOTES:

- CONNECTIONS SHOWN ARE FOR A TYPICAL THERMOSTAT. SEE SCHEMATIC SUPPLIED WITH THERMOSTAT FOR PROPER CONNECTIONS. LOW VOLTAGE WIRING TO UNIT MAY BE NEC CLASS 2 AND MUST BE A MIN. OF 18 A.W.G. FOR SINGLE OR TWO STAGE THERMOSTAT SET THE HEAT ANTICIPATOR TO .4 AMPS.
- MAXIMUM ADDITIONAL EXTERNAL LOAD (PILOT DUTY) BETWEEN "B" AND "R" OF 0.5 AMPS. 24 VAC IS AVAILABLE IN COOLING MODE ONLY.
- FOR 208 VOLT OPERATION MAKE THE FOLLOWING WIRING CHANGES:
 A: AT TNS1 REMOVE 1J(RD) WIRE AND CONNECT TO THE 208 TERMINAL ON THE TRANSFORMER.
 B: AT TNS2 DISCONNECT RED FROM 11A(RD) AND CONNECT ORANGE WIRE. THE RED WIRE MUST BE RE-TERMINATED TO AVOID ACCIDENTLY SHORTING.
- IF ANY OF THE ORIGINAL WIRE AS SUPPLIED IN THIS UNIT MUST BE REPLACED REPLACE IT WITH APPLIANCE WIRING MATERIAL RATED AT 105°C.
- THE ICM MOTOR HAS INTERNAL THERMAL PROTECTION.
- IF OPTIONAL HUMIDISTAT ACCESSORY IS USED ON ICM CUT THE "BK JUMPER" AND CONNECT THE HUMIDISTAT BETWEEN THE TERMINALS "R" AND "BK".
- THE GREEN LED ON THE ICMC BOARD FLASHES ONCE PER HUNDRED CFM.
- THE OUTDOOR FAN AND COMPRESSOR 2 CAPACITOR IS LOCATED IN THE HEATER AREA.

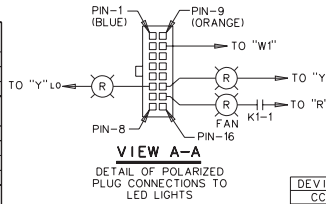

WIRE COLOR DESIGNATION		
ABBRI	COLOR	ABBRI
ABBRI	COLOR	ABBRI
ABBRI	COLOR	ABBRI
ABBRI	COLOR	ABBRI
ABBRI	COLOR	ABBRI
ABBRI	COLOR	ABBRI
ABBRI	COLOR	ABBRI
ABBRI	COLOR	ABBRI
ABBRI	COLOR	ABBRI
ABBRI	COLOR	ABBRI

DEVICE	DESCRIPTION	LINE
CC	COMPRESSOR CONTACTOR COIL	49
OFC	OUTDOOR FAN CAPACITOR	16
CF 3	COMB. FAN MOTOR CAPACITOR	22
CN	CONNECTOR OR WIRE NUT	40
CFM	COMBUSTION FAN MOTOR	24
CPR	COMPRESSOR	11
CR	COMPRESSOR RUN CAPACITOR	11
CS	COMPRESSOR START CAPACITOR	7
CSR	COMPRESSOR START RELAY COIL	7
F	INDOOR BLOWER RELAY	45,46
FD	FLAME DETECTOR	40
FL	FUSEABLE LINK	37
TBA	FAN TERMINAL BLOCK	18
GV	GAS VALVE	30-39
ICM	INTEGRATED COMMUTATED MOTOR	20
ICMC	INTEGRATED COMMUTATED MOTOR CONTROL	51-60
IGN	IGNITION CONTROL MODULE	23,31
IOL	INTERNAL OVERLOAD	42
IP	IGNITOR PROBE	42
LED	IGN DIAGNOSTICS INDICATOR	37
ODM	OUTDOOR FAN MOTOR	15
PP	POLARIZED PLUG	39
PS	PRESSURE SWITCH	35
TCO	TEMPERATURE LIMIT SWITCH	35
TNS1&2	CONTROL POWER TRANSFORMER	23&29

Typical Wiring

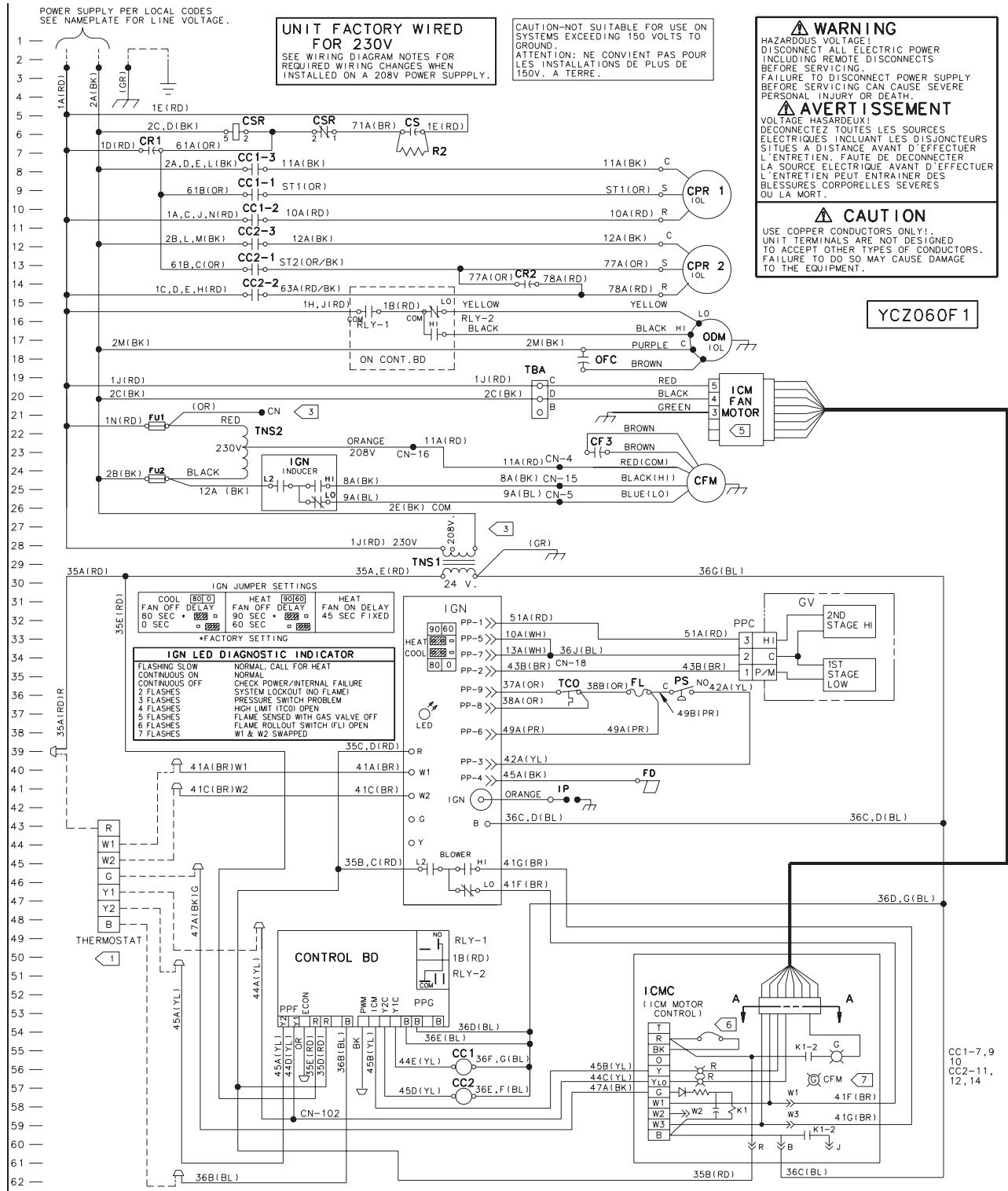

Dimensions

BAYCURB033A Roof Mounting Curb Outline YCZ036F — Unit

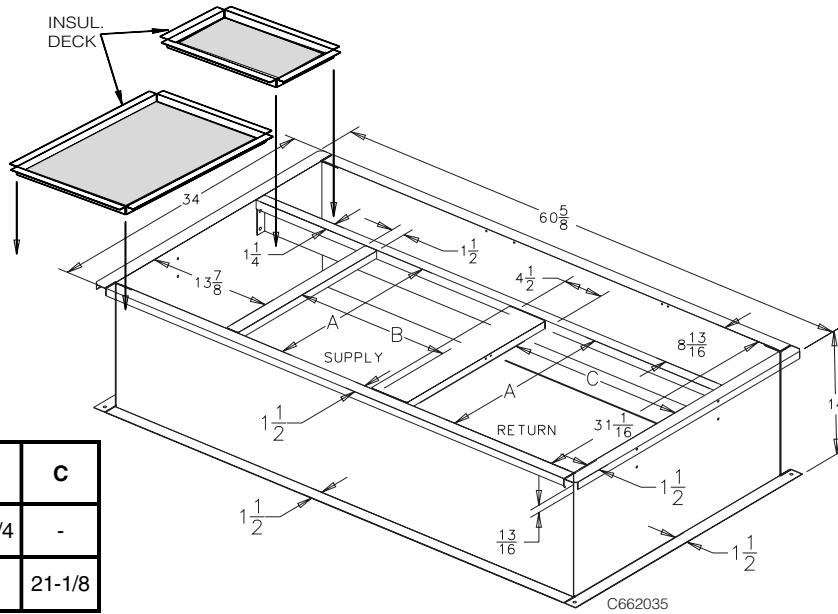

AIR DUCT OPENINGS	A	B	C
SUPPLY DUCT	21	16-3/4	-
RETURN DUCT	21	-	21-1/8

Required Clearance for Unit Installation and Roof Penetration Hole Size Required

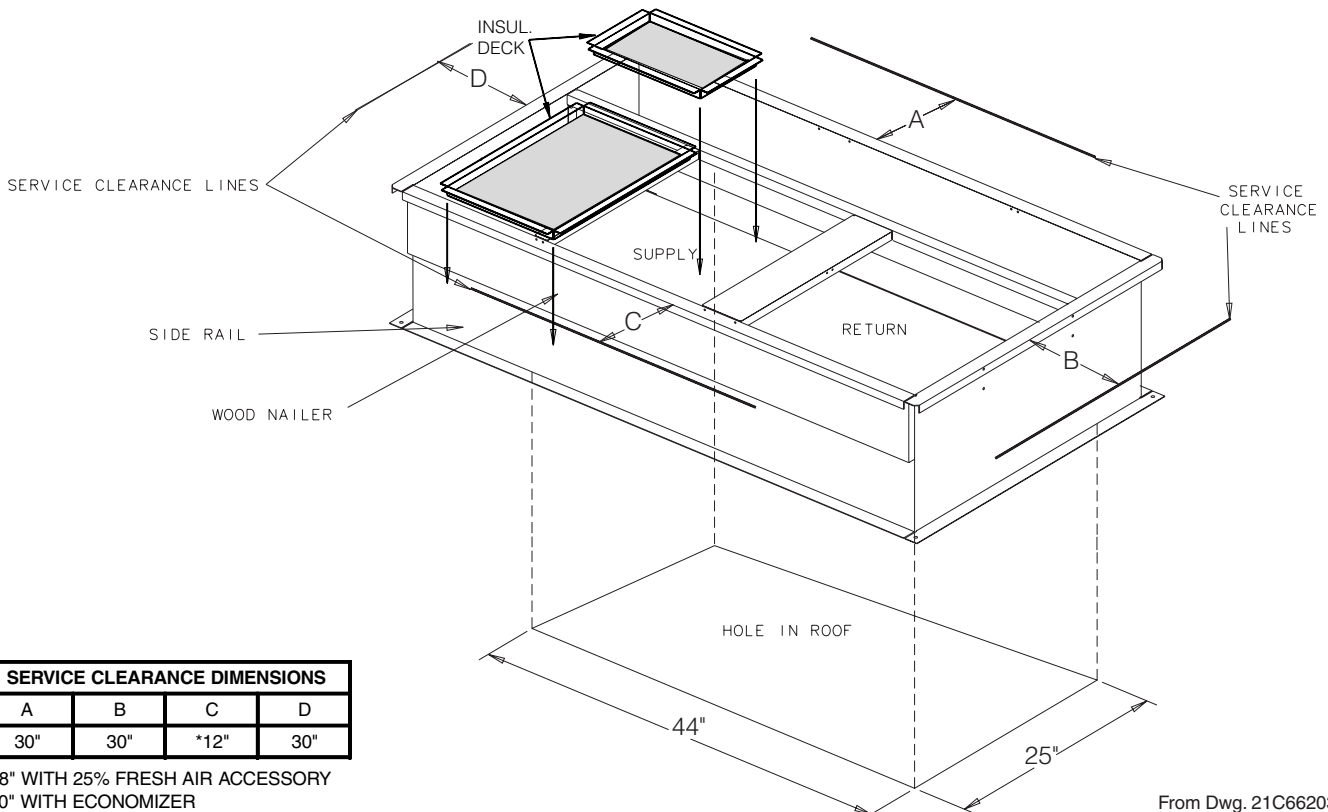

SERVICE CLEARANCE DIMENSIONS			
A	B	C	D
30"	30"	*12"	30"

*18" WITH 25% FRESH AIR ACCESSORY
30" WITH ECONOMIZER

From Dwg. 21C662039

Dimensions

BAYCURB034A Roof Mounting Curb Outline YCZ050,060F — Units

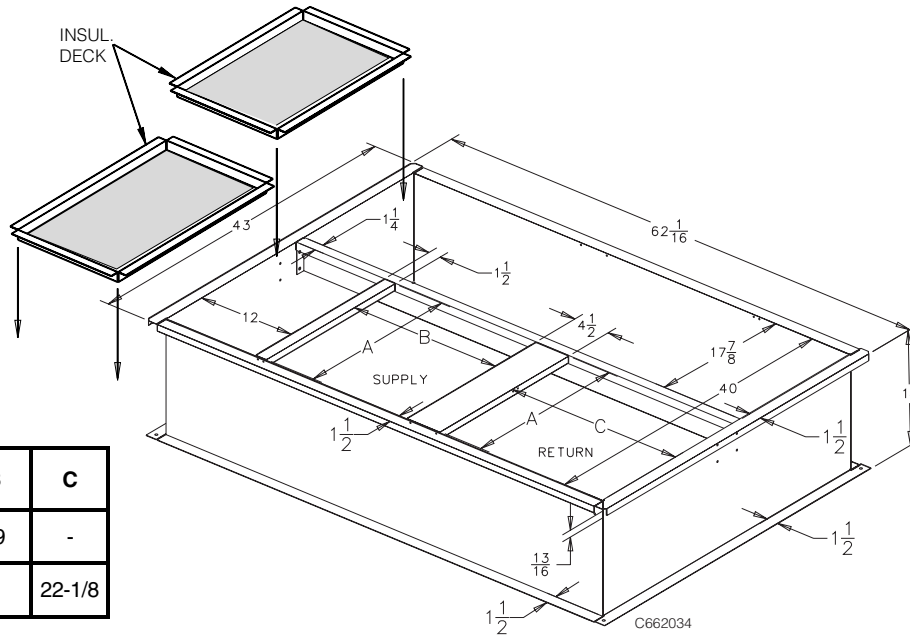

AIR DUCT OPENINGS	A	B	C
SUPPLY DUCT	21	19	-
RETURN DUCT	21	-	22-1/8

Required Clearance for Unit Installation and Roof Penetration Hole Size Required

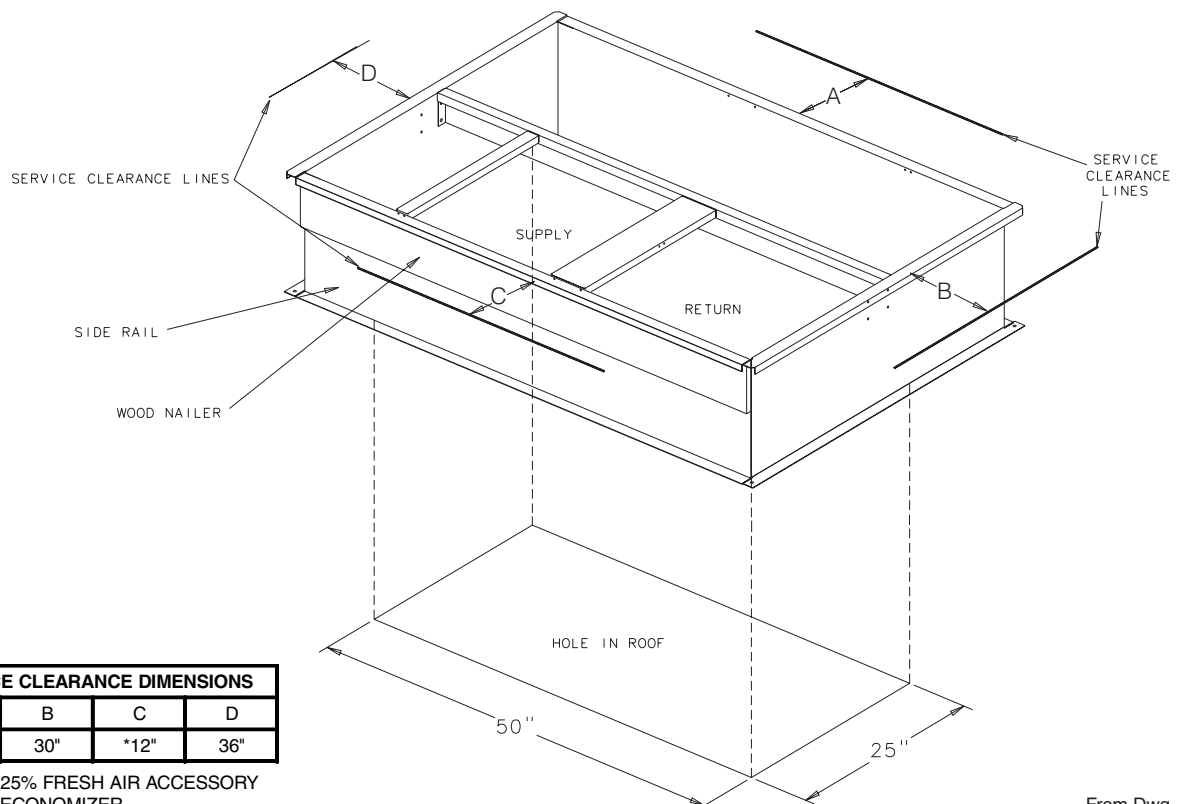

SERVICE CLEARANCE DIMENSIONS			
A	B	C	D
42"	30"	*12"	36"

*18" WITH 25% FRESH AIR ACCESSORY
30" WITH ECONOMIZER

From Dwg. 21C662038

Dimensions

Field Fabricated (Side X Side) Ducts — YCZ036,050,060F Units Installed from Above Mounting Curb

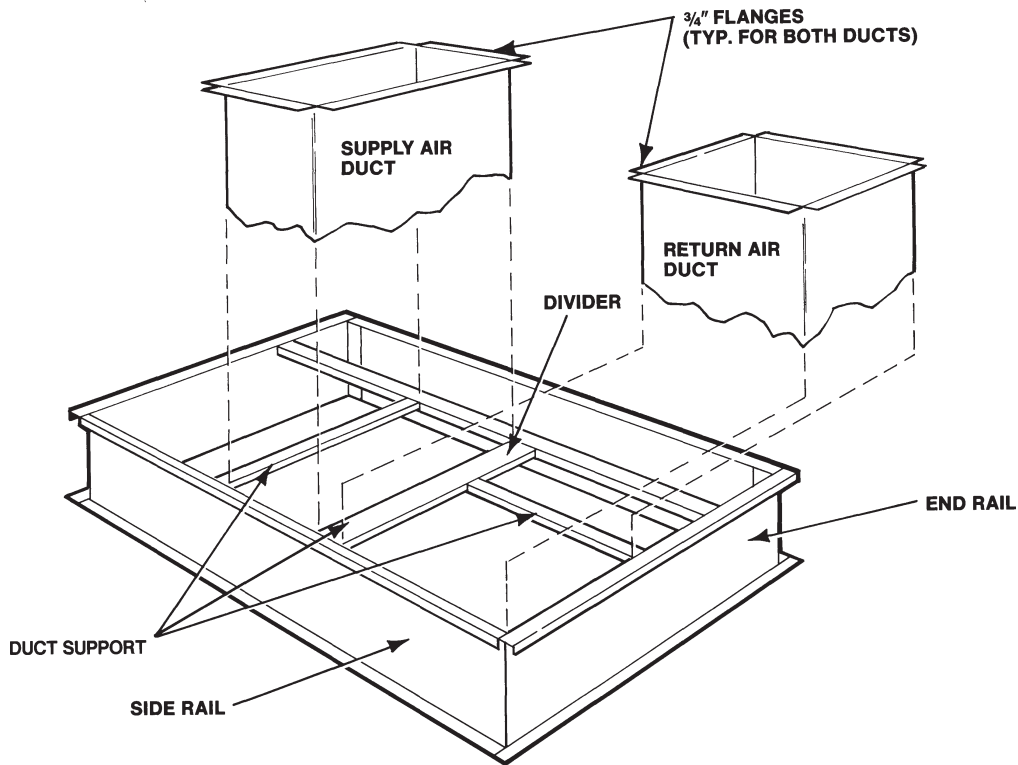

P.V.C. Rubber Gasket Position on BAYCURB033,034A for Unit Placement — YCZ036,050,060F Units

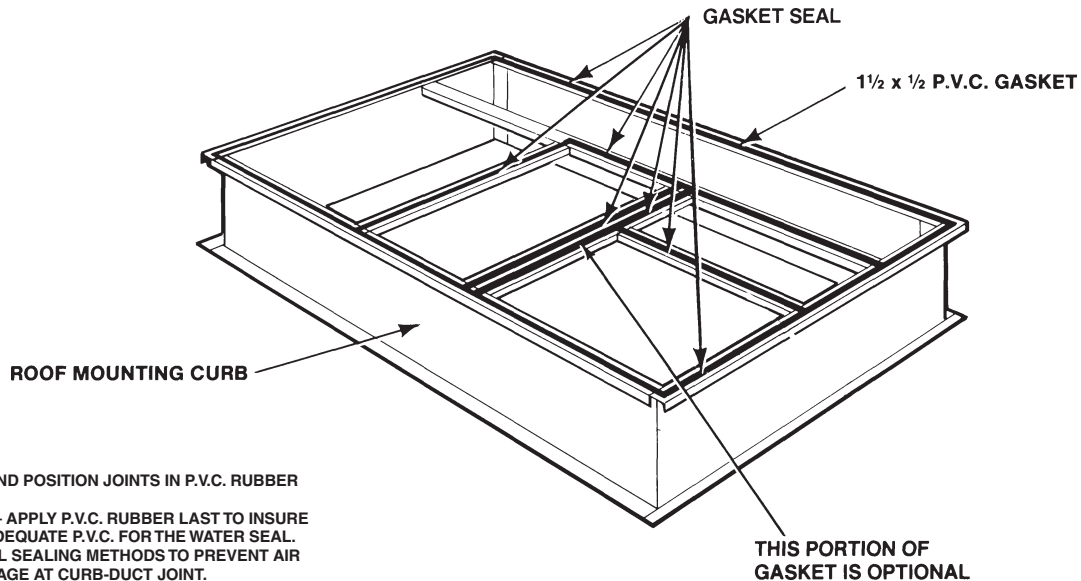

NOTES:

1. OVERLAP AND POSITION JOINTS IN P.V.C. RUBBER GASKET.
2. AIR SEALS – APPLY P.V.C. RUBBER LAST TO INSURE THERE IS ADEQUATE P.V.C. FOR THE WATER SEAL.
3. USE TYPICAL SEALING METHODS TO PREVENT AIR DUCT LEAKAGE AT CURB-DUCT JOINT.

THIS PORTION OF GASKET IS OPTIONAL

Dimensions

YCZ036,050,060F OUTLINE DRAWING — Front
 NOTE: ALL DIMENSIONS ARE IN INCHES

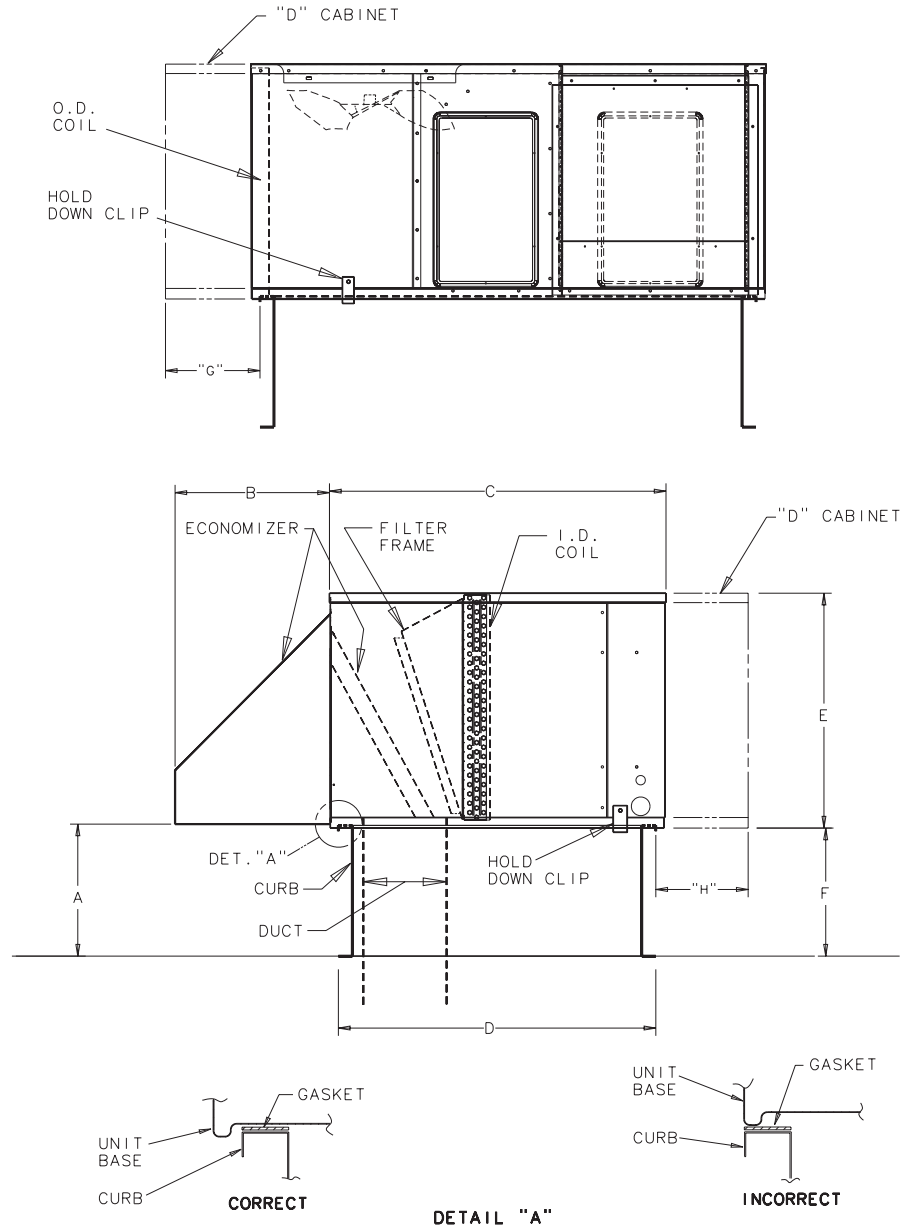

CABINET SIZE	MODEL	BAYCURB	"A"	"B"	"C"	"D"	"E"	"F"	"G"	"H"
"C"	YCZ036F-H	033A	14-13/16	16-5/8	36	34	29-3/16	13-3/4	--	--
"D"	YCZ050F-H YCZ060F-M	034A	14-13/16	21	45	43	33-3/8	13-3/4	--	--

From Dwg. 21D661772



Dimensions

YCZ036,050,060F OUTLINE DRAWING — Rear

NOTE: ALL DRAWING DIMENSIONS ARE IN MM (INCHES)

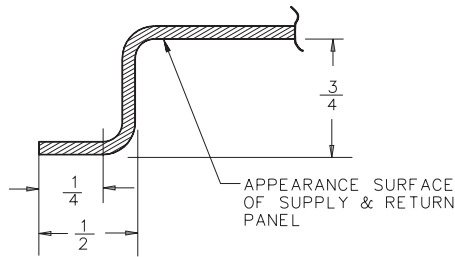
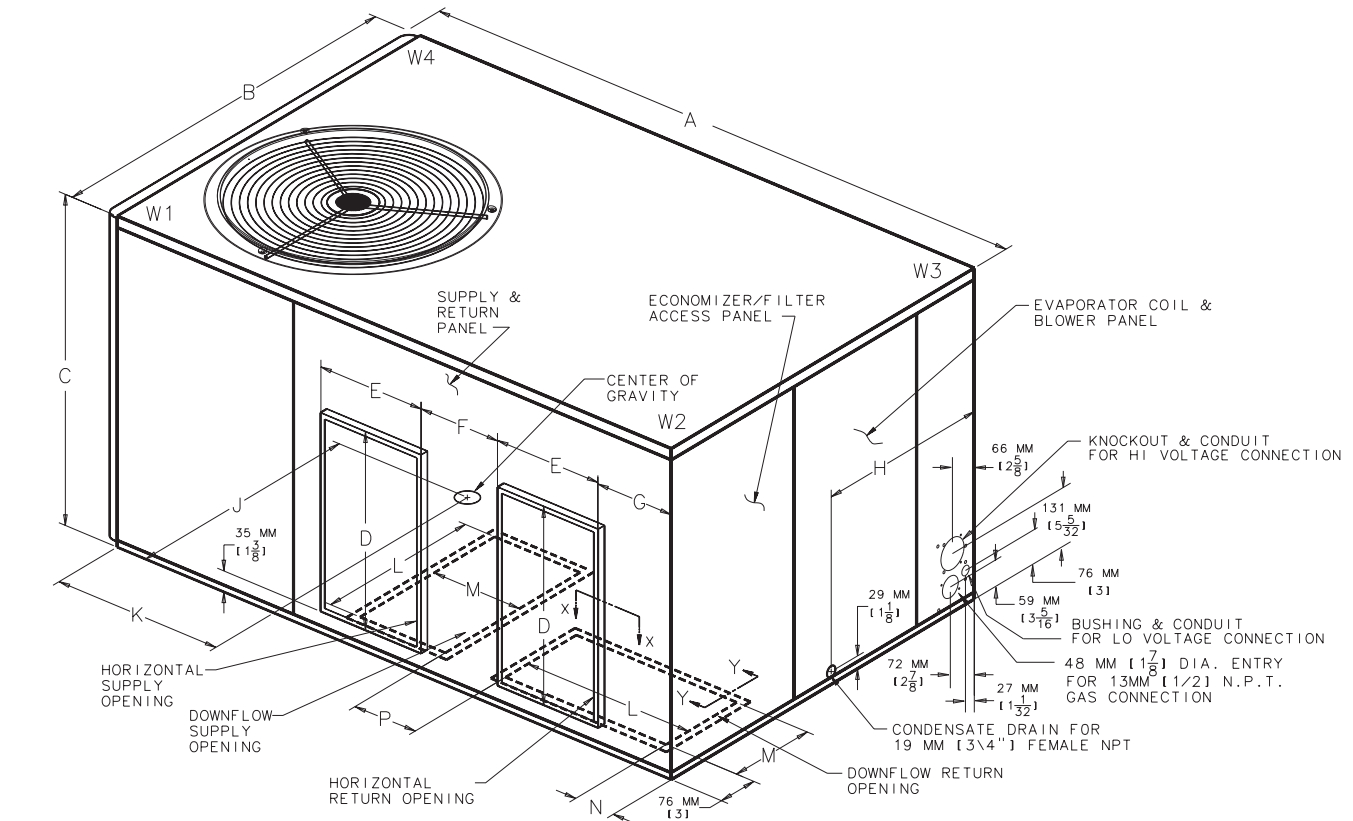

SECT. X-X

TYPICAL CROSS SECTION OF SUPPLY & RETURN PERIMETER FLANGES

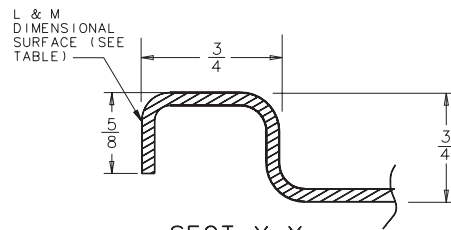

SECT Y-Y

TYPICAL CROSS SECTION OF DOWNFLOW SUPPLY & RETURN PERIMETER FLANGES

MODEL	CORNER WEIGHT (LBS)				NET UNIT WEIGHT (LBS)	A	B	C	D	E	F	G	H	J	K	L	M	N	P
	W1	W2	W3	W4															
YCZ036F	161	106	104	157	528	64	36	29-3/16	18-9/16	11-1/16	6-9/16	11-1/8	17	18-1/2	25-1/2	17-1/2	10	3	8-3/4
YCZ050F	172	121	137	196	626	65-1/8	45	33-3/8	21-1/16	15-1/16	4-15/16	9-1/8	21-15/16	24	26-1/2	20	14	3-1/2	8-5/16
YCZ060F	195	129	132	199	656									22-3/4	25-1/2				

NOTE: TABLE IN INCHES ONLY.

From Dwg. 21D667953

Dimensions

YCZ036,050,060F OUTLINE DRAWING — Front

NOTE: ALL DRAWING DIMENSIONS ARE IN MM (INCHES)

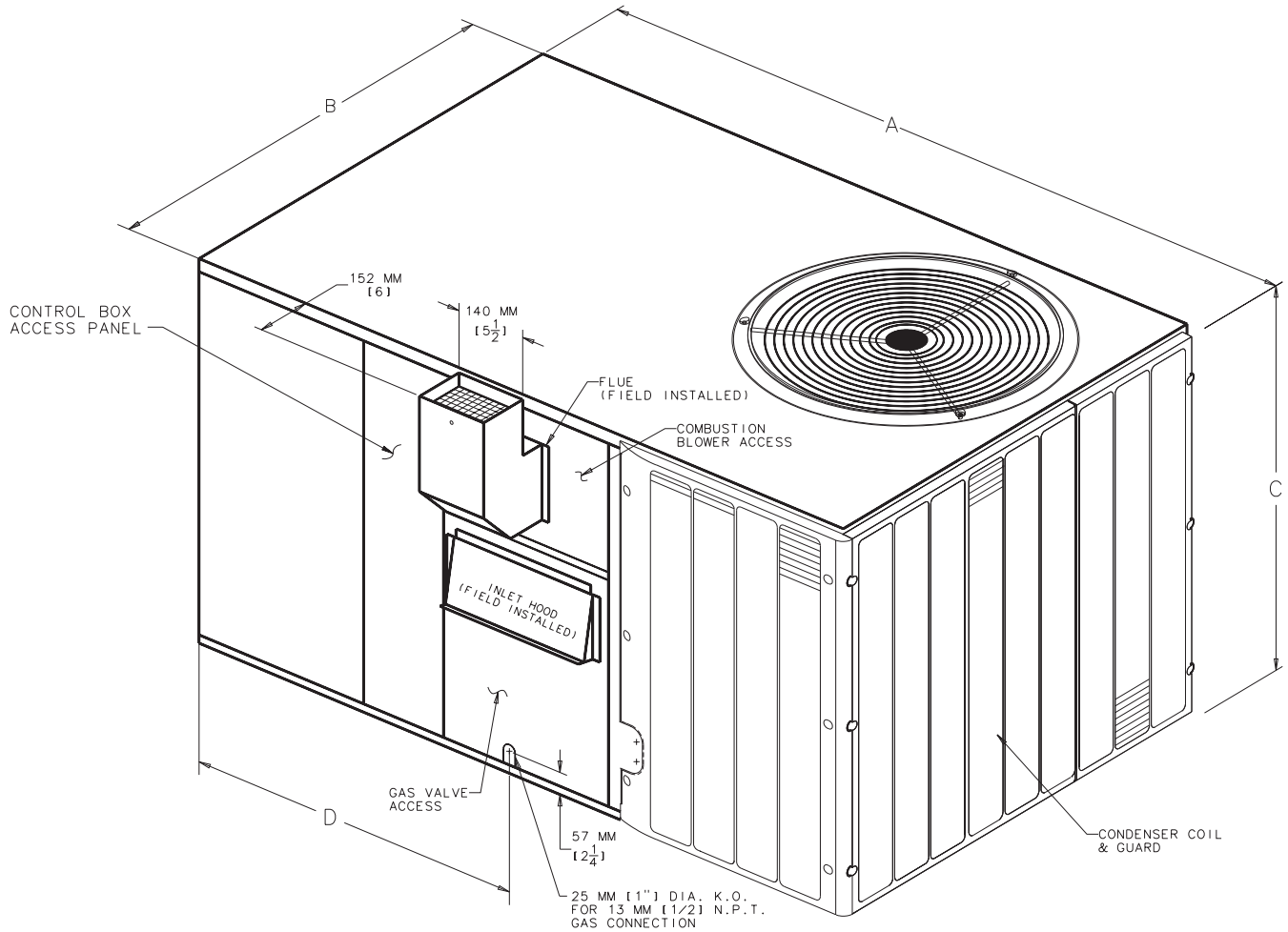

RECOMMENDED SERVICE CLEARANCE	
BACK	* 6.0"
LEFT SIDE	30.0"
RIGHT SIDE	24.0"
FRONT SIDE	30.0"

* 18" WITH FRESH AIR ACCESSORY
* 30" WITH ECONOMIZER

NOTE: TABLE IN INCHES ONLY.

CLEARANCE TO COMBUSTIBLE MATERIAL	
BOTTOM	0.0"
BACK	1.0"
LEFT SIDE	6.0"
RIGHT SIDE	6.0"
FRONT SIDE	12.0"
TOP	36.0"

NOTE: TABLE IN INCHES ONLY.

MODEL	A	B	C	D
YCZ036F-M	64	36	29-3/16	27-1/2
YCZ050F-H YCZ060F-M	65-1/8	45	33-3/8	27-15/16

NOTE: TABLE IN INCHES ONLY.

From Dwg. 21D667952



Mechanical Specification Options

General

All units shall be factory assembled, piped, internally wired and fully charged with R-22. All units shall be designed to operate at outdoor ambient temperatures as high as 115°F. Cooling capacities shall be rated in accordance with A.R.I. standards. The YCZ-F heating/cooling unit design is UL listed, specifically for outdoor applications using propane or natural gas. All units shall be designed for outdoor rooftop or ground level installation. Exterior surfaces of all units shall be phosphatized, zinc-coated steel with epoxy resin primer and baked enamel finish. Shipped for horizontal application, convertible to downflow.

Casings

All panels shall be 20-gauge steel, gasketed and insulated. Foil-faced glass fiber insulation shall be in the heat exchanger section. Mat-faced insulation shall be in the evaporator section. Base pan and mounting rails shall be 18 gauge. **WEATHERGUARD™** exterior corrosion resistant screws shall be used for added resistance to rust and corrosion.

Coil Guards

The **COIL-SAV'R™** end and side grilles shall be Lexan®, louver type. The grilles shall protect the coil from hail, sticks, and handling damage.

Controls

Refrigeration cycle controls shall include condenser fan, evaporator fan and compressor contactors. Compressors shall be equipped with a combination internal winding thermostat/current overload. Internal high pressure relief shall also be provided.

Comfort-R™ System shall provide better humidity control in the cooling mode.

Refrigeration System

Compressors — All units shall have hermetically sealed Climatuff® compressors. Compressors shall be equipped with over

temperature, over current and high pressure protection. Crankcase heaters shall be standard on all three phase models.

Evaporator Coil — Internally enhanced 3/8-inch OD seamless copper tubing mechanically bonded to aluminum fins, factory pressure and leak tested at 250 to 300 psig.

Condenser Coil — Outdoor coils shall be internally enhanced 3/8-inch OD seamless copper tubing mechanically bonded to aluminum fins. Each coil shall be factory pressure and leak tested at 420 psig.

Indoor Air Fan — Direct-drive, forward-curved, centrifugal type. Motor shall have thermal overload protection. Permanently lubricated motor bearings. Motor/blower assembly isolated from unit with rubber mounts.

Condenser Fan — Direct-drive, draw thru propeller type. Weather-proofed permanent split capacitor fan motor shall have built-in thermal overload and permanently lubricated motor bearings.

Low Ambient — Standard refrigerant system operation down to 55°F. Low ambient accessory required for operation in 0°F. ambient condition.

Heating System

Gas-Fired Heating Section — Models shall provide completely assembled, wired and piped gas fired heating systems within unit. Design certified by U.L., specifically for outdoor application. Threaded gas connection on the unit.

Electronic Ignition System — Main burner is lit each time thermostat calls for heat. Flame sensor proves flame and keeps the main burners on. Should a loss of flame occur, the main valve closes and the spark recurs within 0.8 second. When thermostat is satisfied, main burner is extinguished.

Forced Combustion Blower — Insures flame stability under varying wind conditions. Gives higher combustion efficiency and location flexibility.

Heat Exchanger — Aluminized steel tubes. Free floating design.

Burners — 20-gauge aluminized steel. Multi-port inshot.

Accessories

Roof Curb — The roof curb shall be designed to mate with the unit and provide support and complete weather-tight installation when properly installed. Curb shall ship knocked down for field assembly, and include wood nailer strips.

Modulating Economizer — This accessory shall be field installed and be composed of the following items: 0-100% fresh air damper, damper drive motor fixed dry bulb enthalpy control, and low voltage polarized plug for electrical connections. Solid state enthalpy or differential enthalpy control is optional. Economizer operations shall be controlled by the preset position of the enthalpy control. A barometric relief damper shall be standard with the economizer and provide a pressure operated damper that shall be gravity closing and prohibit entrance of outside air on equipment "off" cycle.

Manual Fresh Air Hood — Manual outside air provides a fixed outside air quantity from 0 to 25 percent. Includes hood and birdscreen.

Low Ambient Control — Control allows cycling of compressor under low ambient cooling conditions. Required for cooling operation to 0°F.

Propane Gas Conversion Kit — For conversion from natural gas to LP gas.



Trane
A business of
American Standard Companies
www.trane.com

Literature Order Number	22-1684-03-0203 (EN)	P.I.
File Number	PL-UN-RT-PRC020-EN 02/03	
Supersedes	YCZ-D-1 07/00	
Stocking Location	Webb/Mason-Houston	

Trane has a policy of continuous product and product data improvement and it reserves the right to change design and specifications without notice.