



Product Catalog

Air-Cooled Scroll Chillers/Heat Pumps

Model CGAM 20-160 Nominal Tons

Model CXAM 20-160 Nominal Tons

50 Hertz Version





Introduction

Design and manufacturing excellence makes Trane a leader in the air-cooled chiller market place. This tradition of using excellence to meet market demands is illustrated with the new Trane AquaStream 20-160 ton nominal air-cooled chiller and 20-160 ton nominal heat pump unit. The introduction of this next-generation chiller is an exciting step forward in energy-efficiency, sound, reliability, ease of serviceability, control precision, application versatility, and operational cost-effectiveness. The new chiller is designed to deliver proven AquaStream performance based on the redesign of a European model that has been a market leader, plus all the benefits of new heat transfer and fan designs, as well as, low-speed, direct-drive scroll compressors.

Important Design Advances and New Features

- Higher full-load and part-load energy efficiency that reduce operating costs.
- Significantly lower noise levels than other scroll compressor chillers.
- HFC-410A optimized design.
- Factory-installed evaporator pump and buffer tank available to make installation easier.
- Flow switch and water strainer are factory installed in the optimum locations for seamless operation and reduced chiller installation and maintenance time.
- Trane CH530™ with Adaptive Controls™ have improved fan algorithms for more reliable operation at extreme conditions.
- Single chiller time of day scheduling communication for easier control of small jobs.
- Easily integrated with existing BAS via Modbus™, LonTalk™, or BACnet™ communication interface.
- All major service components are close to the unit edge for safe and easy maintenance.
- The chiller is designed for easy serviceability with input from our extended experience in design, testing and field operation.

Trane and the Trane logo, AquaStream, CH-530, Adaptive Controls, System Analyzer™ and TRACE™ are trademarks of Trane in the United States and other countries. All trademarks referenced in this document are the trademarks of their respective owners.

Table of Contents

Features and Benefits	4
Application Considerations	7
Model Number Descriptions	14
General Data	16
Controls	24
Electrical Data	28
Electrical Connections	32
Dimensions	36
Weights	44



Features and Benefits

Reliability

- Years of laboratory testing, including running the chiller at extreme operating conditions, have resulted in optimized compressor and chiller systems reliability by confirming a robust design and verifying quality each step of the way.
- Direct-drive, low-speed scroll compressors with fewer moving parts provide maximum efficiency, high reliability, and low maintenance requirements. Suction gas-cooled motor stays at a uniformly low temperature for long motor life.
- The third generation microprocessor control system provides improved control capabilities with Adaptive Control to keep the unit operating even in adverse conditions. Advanced microelectronics protect both the compressor and the motor from typical electrical fault conditions like thermal overload and phase rotation.
- Standard factory-installed water strainer helps prevent system debris from affecting unit flow or heat transfer.
- Flow switch is factory-installed at the optimum location in the piping for reduced chiller installation cost and superior flow sensing, reducing the potential for nuisance trips.
- Exceptionally rigid condenser coil structure is manufactured with hairpin tubes which halves the number of braze joints significantly reducing the potential for leaks.
- Innovative condenser pressure integrated fan control algorithms provide more reliable operation at extreme temperature conditions.

Life Cycle Cost-Effectiveness

- Industry leading full- and part-load efficiency
- Electronic expansion valve and high speed suction temperature sensor enables tight chilled water temperature control and low superheat, resulting in more efficient full-load and part-load operation than previously available.
- Partial heat recovery available to save energy on pre-heat or reheat applications.
- The factory-installed and tested pump package is available with many options to meet a variety of customer needs.

Application Versatility

- Industrial/low temperature process cooling - Excellent operating temperature range and precise control capabilities enable tight control.
- Ice/thermal storage - Utilities and owners benefit from reduced cooling energy cost. The AquaStream chiller's dual setpoint control and industry leading ice energy storage efficiency assures reliable operation and superior system efficiency.
- Partial heat recovery - An optional factory-installed heat exchanger provides hot water for many needs; water preheat and reheat for enhanced system humidity control are just two. This option reduces operating costs associated with boilers/domestic hot water.

Simple, Economical Installation

- Standard sound levels are roughly 5-8 dBA less than the previous Trane air-cooled models, perfect for applying outdoor HVAC equipment in neighborhoods, such as K-12 schools. There are a variety of sound options to help meet many different job site requirements: compact, super quiet and comprehensive acoustic package.
- System integration available with LonTalk, BACnet, or ModBus, through a single twisted-pair wire for a less expensive translation to an existing building automation system.
- Powder-coated paint provides superior durability, corrosion protection, and is less likely to be damaged while rigging/lifting/installing the chiller.
- Single point power connection installation
- Factory commissioned unit-mounted starter reduces overall job cost and improves system reliability by eliminating job site design, installation and labor coordination requirements.

Precision Control

- Microprocessor-based Trane CH530 controls monitor and maintain optimal operation of the chiller and its associated sensors, actuators, relays, and switches, all of which are factory-installed, powered up and tested prior to shipping.
- Adaptive Control maintains chiller operation under adverse conditions, when many other chillers might simply shut down. Operating conditions that are compensated for include high condensing pressure and low suction pressure.
- AquaStream advanced microprocessor controls enable variable primary flow applications providing chilled water temperature control accuracy of $\pm 2^{\circ}\text{F}$ (1.1°C) for flow changes up to 10 percent per minute, plus handling of flow changes up to 30 percent per minute with continuous operation.
- Easy-to-use operator interface displays all operating and safety messages, with complete diagnostics information, on a highly readable panel with a scrolling touch-screen display. Status and diagnostic messages are in plain language - no codes to interpret - and are available in 20 languages.

Improved Serviceability

- All major serviceable components are close to the edge. Service shutoff valves and water strainer are conveniently located to enable easy service.
- Water piping connections are factory piped to the edge of the unit to make installation safer and faster.
- Electronic expansion valve designed so controls can be removed and serviced without refrigerant handling.
- The optional pump package is designed to be serviced in place. The unit structure includes a rigging point for pump servicing, making inspection, cleaning and pump seal changes easier.
- High pressure transducer and temperature sensors mountings enable troubleshooting and replacement without removing refrigerant charge, greatly improving serviceability over the life of the unit.
- Dead front panel construction provides for enhanced service technician safety.



Features and Benefits



Application Considerations

Certain application constraints should be considered when sizing, selecting and installing Trane AquaStream CGAM and CXAM units. Unit and system reliability is often dependent upon proper and complete compliance with these considerations. Where the application varies from the guidelines presented, it should be reviewed with your local Trane sales engineer.

Note: *The terms water and solution are used interchangeably in the following paragraphs.*

Unit Sizing

Intentionally over-sizing a unit to assure adequate capacity is not recommended. Erratic system operation and excessive compressor cycling are often a direct result of an oversized unit. In addition, an oversized unit is usually more expensive to purchase, install, and operate. If over sizing is desired consider using two smaller units.

Water Treatment

The use of untreated or improperly treated water in units may result in scaling, erosion, corrosion, and algae or slime buildup. This will adversely affect heat transfer between the water and system components. Proper water treatment must be determined locally and depends on the type of system and local water characteristics.

Neither salt nor brackish water is recommend for use in Trane air-cooled AquaStream units. Use of either will lead to a shortened life. Trane encourages the employment of a qualified water treatment specialist, familiar with local water conditions, to assist in the establishment of a proper water treatment program.

Foreign matter in the chilled water system can also increase pressure drop and, consequently, reduce water flow. For this reason it is important to thoroughly flush all water piping to the unit before making the final piping connections to the unit.

Effect of Altitude on Capacity

At elevations substantially above sea level, the decreased air density will decrease condenser capacity and, therefore, unit capacity and efficiency.

Ambient Limitations

Trane AquaStream units are designed for year-round operation over a range of ambient temperatures. The air-cooled model CGAM chiller will operate in ambient temperatures of up to 52°C. Selecting the wide ambient option will allow the chiller to operate down to -18°C. Without the wide ambient option freeze damage can occur with operation between 0°C and 12.8°C depending on the unit tonnage. The heat pump model CXAM with standard ambient will operate in cooling mode with ambient temperatures of up to 46°C.

The minimum ambient temperatures are based on still conditions (winds not exceeding five mph). Greater wind velocities will result in a drop in head pressure, therefore increasing the minimum starting and operating ambient temperature. The Adaptive Control microprocessor will attempt to keep the unit on-line when high or low ambient conditions exist, making every effort to avoid nuisance trip-outs and provide the maximum allowable tonnage.

Water Flow Limits

The minimum water flow rates are given in the General Data section of this catalog. Brazed plate heat exchanger flow rates below the tabulated values will result in laminar flow causing freeze-up problems, scaling, stratification and poor control. The maximum water flow rate is also given. Flow rates exceeding those listed may result in very high pressure drop across the heat exchanger.

Flow Rates Out of Range

Many process cooling jobs require flow rates that cannot be met with the minimum and maximum published values within the AquaStream brazed plate heat exchanger. A simple piping change can alleviate this problem. For example: a plastic injection molding process requires 5.0 l/s of 10°C water and returns that water at 15.6°C. The selected unit can operate at these temperatures, but has a minimum flow rate of 6.6 l/s. The system layout in Figure 1 can satisfy the process.

Figure 1. Flow Rate Out of Range Systems Solution

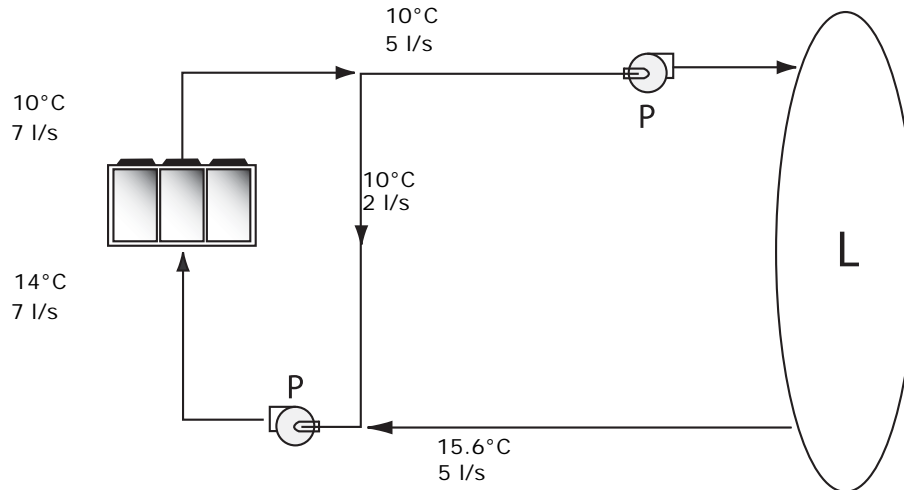

Flow Proving

Trane provides a factory-installed water flow switch monitored by CH530 which protects the unit from operating in loss of flow conditions.

Variable Flow in the Brazed Plate Heat Exchanger

An attractive chilled water system option may be a Variable Primary Flow (VPF) system. VPF systems present building owners with several cost-saving benefits when compared with Primary/Secondary chilled water systems. The most obvious cost savings results from eliminating the constant volume chiller pump(s), which in turn eliminates the related expenses of the associated piping connections (material, labor), and electrical service and switch gear. In addition to the installed cost advantage building owners often cite pump related energy savings as the reasons that prompted them to select a VPF system.

The AquaStream has the capability to handle variable flow without losing leaving water temperature control. The microprocessor and capacity control algorithms are designed to take a 10 percent change in water flow rate per minute while maintaining a $\pm 1.1^\circ\text{C}$ leaving water temperature control accuracy. The unit tolerates up to 30 percent per minute water flow variation as long as the flow is equal or above the minimum flow rate requirement.

With the help of a software analysis tool such as System Analyzer™, DOE-2 or TRACE™, you can determine whether the anticipated energy savings justify the use of variable primary flow in a particular application. Existing constant flow chilled water systems may be relatively easily converted to VPF and benefit greatly from the inherent efficiency advantages.

Water Temperature

Leaving Water Temperature Limits

Trane AquaStream chillers have three distinct leaving water categories:

- standard, with a leaving solution range of 5.5 to 18°C
- low temperature process cooling, with leaving solution range of -12 to 18°C
- ice-making, with leaving solution range of -7 to 18°C

Since leaving solution temperature below 5.5°C results in suction temperature at or below the freezing point of water, a glycol solution is required for all low temperature and ice-making machines. Ice making control includes dual setpoint controls and safeties for ice making and standard cooling capabilities. Consult your local Trane sales engineer for applications or selections involving low temperature or ice making machines.

The maximum water temperature that can be circulated through the CGAM brazed plate heat exchanger when the unit is not operating is 51.7°C. For the CXAM the water temperature limit is 60°C. Heat exchanger damage may result above this temperature.

Leaving Water Temperature Out of Range

Similar to the flow rate limitations above, many process cooling jobs require temperature ranges that are outside the allowable minimum and maximum operating values for the unit. Figure 2 below shows a simple example of a mixed water piping arrangement change that can permit reliable unit operation while meeting such cooling conditions. For example, a laboratory load requires 15 l/s of water entering the process at 30°C and returning at 35°C. The unit's maximum leaving chilled water temperature of 15.6°C. In the example shown, both the unit and process flow rates are equal, however, this is not necessary. For example, if the unit had a higher flow rate, there would simply be more water bypassing and mixing with warm water returning to the unit.

Figure 2. Temperature Out of Range System Solution

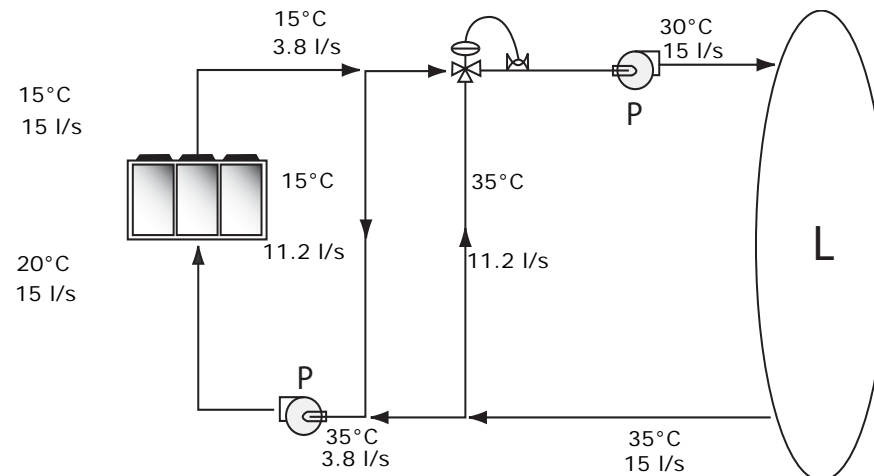

Application Considerations

Supply Water Temperature Drop

Full load chilled water temperature drops from 3.3 to 10°C may be used as long as minimum and maximum water temperature and minimum and maximum flow rates are not violated.

Temperature drops outside this range at full load conditions are beyond the optimum range for control and may adversely affect the microcomputer's ability to maintain an acceptable supply water temperature range. Furthermore, full load temperature drops of less than 3.3°C may result in inadequate refrigerant superheat which is critical to long term efficient and reliable operation. Sufficient superheat is always a primary concern in any refrigerant system and is especially important in a packaged unit where the brazed plate heat exchanger is closely coupled to the compressor.

Typical Water Piping

All building water piping must be flushed prior to making final connections to the unit. To reduce heat loss and prevent condensation, insulation should be applied. Expansion tanks are also usually required so that chilled water volume changes can be accommodated.

Avoidance of Short Water Loops

Adequate chilled water system water volume is an important system design parameter because it provides for stable chilled water temperature control and helps limit unacceptable short cycling of unit compressors.

The AquaStream unit's temperature control sensor is located in the supply (outlet) water connection or pipe. This location allows the building to act as a buffer to slow the rate of change of the system water temperature. If there is not a sufficient volume of water in the system to provide an adequate buffer, temperature control can suffer, resulting in erratic system operation and excessive compressor cycling.

Typically, a two-minute water loop circulation time is sufficient to prevent short water loop issues. Therefore, as a guideline, ensure the volume of water in the chilled water loop equals or exceeds two times the brazed plate heat exchanger flow rate. For systems with a rapidly changing load profile the amount of volume should be increased.

If the installed system volume does not meet the above recommendations, the following items should be given careful consideration to increase the volume of water in the system and, therefore, reduce the rate of change of the return water temperature.

- A volume buffer tank located in the return water piping.
- Larger system supply and return header piping (which also reduces system pressure drop and pump energy use).

An optional factory-installed buffer tank is designed to meet the minimum two minute loop time without additional job site piping. The buffer tank can also be used on jobs that already meet or exceed the minimum loop time to further reduce the potential for compressor cycling, increasing the compressor life span, and reducing system temperature fluctuations.

Minimum water volume for a process application

If a unit is attached to an on/off load such as a process load, it may be difficult for the controller to respond quickly enough to the very rapid change in return solution temperature if the system has only the minimum water volume recommended. Such systems may cause unit low temperature safety trips or in the extreme case heat exchanger freezing. In this case, it may be necessary to add or increase the size of the mixing tank in the return line or consider the optional factory-installed buffer tank with the unit.

Multiple Unit Operation

Whenever two or more units are used on one chilled water loop, Trane recommends that their operation be coordinated with a higher level system controller for best system efficiency and reliability. The Trane Tracer system has advanced chilled plant control capabilities designed to provide such operation.

Ice Storage Operation

An ice storage system uses the chiller to make ice at night when utilities generate electricity more efficiently and charge less for electricity with lower demand and energy charges. The stored ice reduces or even replaces mechanical cooling during the day when utility rates are at their highest. This reduced need for cooling results in significant utility cost savings and source energy savings.

Another advantage of an ice storage system is its ability to eliminate chiller over sizing. A "rightsized" chiller plant with ice storage operates more efficiently with smaller support equipment while lowering the connected load and reducing operating costs. Best of all this system still provides a capacity safety factor and redundancy by building it into the ice storage capacity for practically no cost compared to over sized systems.

The Trane air-cooled chiller is uniquely suited to low temperature applications like ice storage because of the ambient relief experienced at night. Chiller ice making efficiencies are typically similar to or even better than standard cooling daytime efficiencies as a result of night-time dry-bulb ambient relief.

Standard smart control strategies for ice storage systems are another advantage of the AquaStream chiller. The dual mode control functionality are integrated right into the chiller. Trane Tracer building management systems can measure demand and receive pricing signals from the utility and decide when to use the stored cooling and when to use the chiller.

Partial Heat Recovery Operation

Partial heat recovery is designed to salvage a portion of the heat that is normally rejected to the atmosphere through the air-cooled condenser coil and put it to beneficial use. With the addition of a heat recovery cycle, heat removed from the building cooling load can be transferred to a preheat application. Keep in mind that the heat recovery cycle is only possible if a cooling load exists to act as a heat source.

To provide a heat recovery cycle, a supplemental heat exchanger is mounted in series to the air-cooled condenser. The supplemental heat exchanger is piped into a preheat circuit. During the heat recovery cycle, the unit operates just as it does in the cooling-only mode except that a portion of the cooling load heat is rejected to the water heating circuit rather than to the air through the air-cooled condenser. Water circulated through the heat recovery heat exchanger by the pumps absorbs cooling load heat from the compressed refrigerant gas discharged by the compressors. The heated water is then used to satisfy heating requirements.

Partial heat recovery can be used in applications where hot water is needed for use in kitchens, lavatories, etc. It is comparatively smaller in size and its heating capacity is not controlled. The partial heat recovery heat exchanger cannot operate alone without a load on the unit.

The partial heat recovery heat exchanger can get up to 157°F (69.4°C) leaving temperature. For more information see the Performance Selection Program.

Unit Placement

Setting The Unit

A base or foundation is not required if the selected unit location is level and strong enough to support the unit's operating weight (see "Weights" section of this catalog).

For a detailed discussion of base and foundation construction, refer to the sound engineering bulletin or the unit IOM. Manuals are available through the local Trane office.

HVAC equipment must be located to minimize sound and vibration transmission to the occupied spaces of the building structure it serves. If the equipment must be located in close proximity to a building, it should be placed next to an unoccupied space such as a storage room, mechanical room, etc. It is not recommended to locate the equipment near occupied, sound sensitive areas of the building or near windows. Locating the equipment away from structures will also prevent sound reflection, which can increase sound levels at property lines or other sensitive points.

Isolation and Sound Emission

Structurally transmitted sound can be reduced by elastomeric vibration eliminators or spring isolators. Elastomeric or spring isolators are generally effective in reducing vibratory noise generated by compressors, and therefore, are recommended for sound sensitive installations. An acoustical engineer should always be consulted on critical applications.

Figure 3. Installation Example

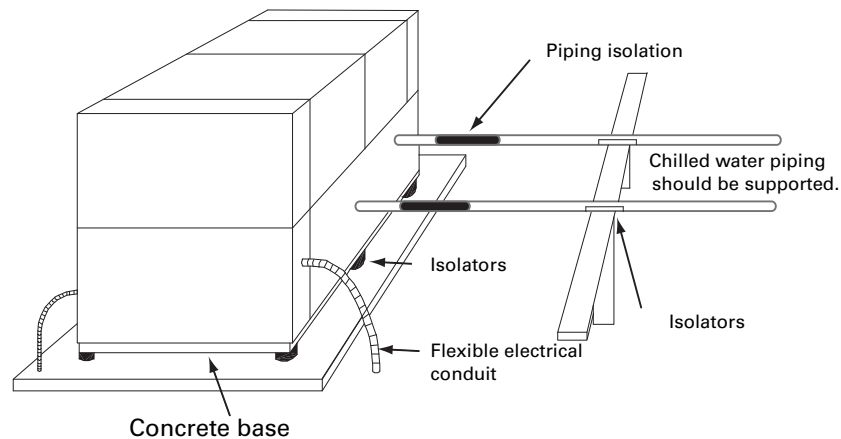

For maximum isolation effect, water lines and electrical conduit should also be isolated. Wall sleeves and rubber isolated piping hangers can be used to reduce the sound transmitted through water piping. To reduce the sound transmitted through electrical conduit, use flexible electrical conduit.

Local codes on sound emissions should always be considered. Since the environment in which a sound source is located affects sound pressure, unit placement must be carefully evaluated. Sound power levels for units are available on request.

Servicing

Adequate clearance for brazed plate heat exchanger and compressor servicing should be provided. Recommended minimum space envelopes for servicing are located in the dimensional data section and can serve as a guideline for providing adequate clearance. The minimum space envelopes also allow for control panel door swing and routine maintenance requirements. Local code requirements may take precedence.

Unit Location

General

Unobstructed flow of condenser air is essential to maintain unit capacity and operating efficiency. When determining unit placement, careful consideration must be given to assure a sufficient flow of air across the condenser heat transfer surface. Two detrimental conditions are possible and must be avoided: warm air recirculation and coil starvation. Air recirculation occurs when discharge air from the condenser fans is recycled back to the condenser coil inlet. Coil starvation occurs when free airflow to the condenser is restricted.

Condenser coils and fan discharge must be kept free of snow or other obstructions to permit adequate airflow for satisfactory unit operation. Debris, trash, supplies, etc., should not be allowed to accumulate in the vicinity of the air-cooled unit. Supply air movement may draw debris into the condenser coil, blocking spaces between coil fins and causing coil starvation.

Both warm air recirculation and coil starvation cause reductions in unit efficiency and capacity because of the higher head pressures associated with them. The air-cooled AquaStream unit offers an advantage over competitive equipment in these situations. Operation is minimally affected in many restricted air flow situations due to its advanced Adaptive Control microprocessor which has the ability to understand the operating environment of the unit and adapt to it by first optimizing its performance and then staying on line through abnormal conditions. For example, high ambient temperatures combined with a restricted air flow situation will generally not cause the unit to shut down. Other units would typically shut down on a high pressure nuisance cut-out in these conditions.

Cross winds, those perpendicular to the condenser, tend to aid efficient operation in warmer ambient conditions. However, they tend to be detrimental to operation in lower ambients due to the accompanying loss of adequate head pressure. Special consideration should be given to low ambient units. As a result, it is advisable to protect air-cooled units from continuous direct winds exceeding 4.5 m/s in low ambient conditions.

The recommended lateral clearances are depicted in the close spacing engineering bulletin available from your local office.

Provide Sufficient Unit-to-Unit Clearance

Units should be separated from each other by sufficient distance to prevent warm air recirculation or coil starvation. Doubling the recommended single unit air-cooled unit clearances will generally prove to be adequate.

Walled Enclosure Installations

When the unit is placed in an enclosure or small depression, the top of the surrounding walls should be no higher than the top of the fans. The unit should be completely open above the fan deck. There should be no roof or structure covering the top of the unit. Ducting individual fans is not recommended.



Model Number Descriptions

Digit 1-4 – Chiller Model

- CGAM = Air-Cooled Scroll Packaged Chiller
- CXAM = Air-Cooled Scroll Heat Pump

Digit 5-7 – Unit Nominal Tonnage

- 020 = 20 Tons
- 023 = 23 Tons
- 026 = 26 Tons
- 030 = 30 Tons
- 035 = 35 Tons
- 040 = 40 Tons
- 046 = 46 Tons
- 052 = 52 Tons
- 060 = 60 Tons
- 070 = 70 Tons
- 080 = 80 Tons
- 090 = 90 Tons
- 100 = 100 Tons
- 110 = 110 Tons
- 120 = 120 Tons
- 140 = 140 Tons
- 150 = 150 Tons
- 160 = 160 Tons

Digit 8 – Unit Voltage

- C = 380 Volt 50 Hz 3 Phase
- E = 400 Volt 50 Hz 3 Phase

Digit 9 – Manufacturing Plant

- 3 = Taicang, China

Digit 10-11 – Design Sequence

- A-Z = Factory/ABU Assigned

Digit 12 – Unit Type

- 2 = High Efficiency/Performance

Digit 13 – Agency Listing

- X = No Agency Listing
- C = GB Standards

Digit 14 – Pressure Vessel Code

- X = No Pressure Vessel Code
- 3 = Chinese Code-China Built Pressure Vessel

Digit 15 – Unit Application

- B = High Ambient (up to 52°C)
- D = Wide Ambient (-18 to 52°C)
- E = Standard Ambient Heat Pump Cooling Mode (up to 46°C)

Digit 16 – Refrigerant Isolation Valves

- 1 = No Isolation Valves
- 2 = Refrigerant Isolation Valves (Discharge Valve)

Digit 17

- A

Digit 18 – Freeze Protection (Factory-Installed Only)

- 1 = With Freeze Protection (External T-Stat Control)

Digit 19 – Insulation

- A = Factory Insulation - All Cold Parts
- B = Insulation for High Humidity/Low Evap Temp

Digit 20 – Factory Charge

- 1 = Full Factory Refrigerant Charge (HFC-410A)

Digit 21 – Evaporator Application

- A = Standard Cooling (5.5 to 18°C)
- B = Low Temperature Processing (lower than 5.5°C)
- C = Ice-Making - hardwired interface (-7 to 18°C)

Digit 22 – Water Connection (Evap)

- 1 = Grooved Pipe Connection
- 2 = Grooved Pipe with Flange Adapter

Digit 23 – Condenser Fin Material

- A = Lanced Aluminum Fins
- B = Non-Lanced Aluminum Fins
- E = Non-Lanced Aluminum Fins w/ Pre-Coat (Black Epoxy)
- F = Non-Lanced Aluminum Fins w/ Pre-Coat (Blue Fin)

Digit 24 – Condenser Heat Recovery

- X = No Heat Recovery
- 1 = Partial Heat Recovery w/ Fan Control
- 2 = Partial Heat Recovery w/o Fan Control (CGAM only)

Digit 25

- X

Digit 26 – Starter Type

- A = Across the Line Starter/ Direct on Line
- B = Solid State Soft Starter

Model Number Descriptions

Digit 27 – Incoming Power Line Connection

- 1 = Single Point Power Connection

Digit 28 – Power Line Connection Type

- A = Terminal Block Conn. For Incoming Lines
- B = Disconnect Switch

Digit 29 – Enclosure Type

- 2 = IP55 Protection

Digit 30 – Unit Operator Interface

- A = Dyna-View/English
- M = Dyna-View/Thai
- N = Dyna-View/Simplified Chinese
- P = Dyna-View/Traditional Chinese

Digit 31 – Remote Interface (digital comm)

- X = No Remote Digital Communication
- 1 = LonTalk LCI-C Interface with Modbus Interface
- 2 = LonTalk/Tracer Summit Interface
- 3 = Time of Day Scheduling
- 4 = BACNet Interface

Digit 32 – Ext. Chilled/Hot Water and Curr. Demand Limit Setpoint

- X = No Ext. Chilled Water Setpoint
- A = Ext Chilled Water and Demand Limit Setpoint - 4-20mA
- B = Ext Chilled Water and Demand Limit Setpoint - 2-10Vdc

Digit 33 – % Capacity

- X = Without % Capacity
- 1 = With % Capacity

Digit 34 – Programmable Relays

- X = No Programmable Relays
- A = Programmable Relays

Digit 35 – Pump Type

- X = No Pumps and no Contactors
- 3 = No Pumps w/ Single Contactors Single High Head Pump
- 4 = No Pumps w/ Dual Contactors Dual High Head Pump
- 6 = Single High Head Pump (20-70 ton only)
- 8 = Dual High Head Pump (80-160 ton only)

Digit 36 – Pump Flow Control

- X = No Pump Flow Control
- A = Pump Flow Controlled by Triple Duty Valve
- B = Pump Flow Controlled by Variable Speed Drive

Digit 37 – Buffer Tank

- X = No Tank
- 1 = With Tank

Digit 38

- X =

Digit 39 – Installation Accessories

- X = No Installation Accessories
- 1 = Elastomeric Isolators
- 2 = Spring Isolators

Digit 40 – Water Strainer

- A = With Water Strainer Factory-Installed

Digit 41 – Sound Attenuator Package

- 1 = Compact
- 5 = Comprehensive Acoustic Package

Digit 42 – Appearance Options

- X = No Appearance Options
- A = Architectural Louvered Panels
- B = Half Louvers
- C = Access Guards
- D = Access Guards and Half Louvers

Digit 43 – Exterior Finish

- 1 = Standard Paint

Digit 44 – Label and Literature Language

- D = English
- F = Chinese - Simple

Digit 45

- X

Digit 46 – Shipping Package

- A = Unit Containerization Package

Digit 47

- X

Digit 48

- X

Digit 49

- X

Digit 50 – Specials

- X = None
- S = Special

Notes:

1. If a digit is not defined it may be held for future use.



General Data

Table 1. General Data - CGAM - Compact Units - 20-70 ton

Size		20	23	26	30	35	40	46	52	60	70
Compressor											
Number	#	2	2	2	2	2	4	4	4	4	4
Tonnage/circuit ¹		10+10	10+13	13+13	15+15	15+20	10+10	10+13	13+13	15+15	15+20
Evaporator											
Water storage	(l)	5.3	5.3	8.2	8.2	12.1	9.1	14.3	15.6	18.9	28.2
Minimum flow ²	(l/s)	1.4	1.5	1.8	2.0	2.3	2.7	3.0	3.5	4.0	4.6
Maximum flow ¹	(l/s)	4.1	4.6	5.3	6.0	6.9	8.0	9.1	10.4	11.9	13.9
Water connection	(mm)	50	50	50	65	65	65	65	80	80	80
Pump Package											
Evap head pressure avail - high head	(kPa)	284.9	255.3	248.6	250.2	248.9	214.1	199.7	182.1	214.5	211.3
Power - high head	(kW)	4	4	4	4	5.5	5.5	5.5	5.5	7.5	7.5
Expansion tank volume	(l)	24	24	24	24	24	24	24	24	24	24
Expansion tank capacity	(l)	350	350	350	350	350	350	350	350	350	350
Buffer tank volume	(l)	542	542	542	542	542	515	515	515	515	515
Condenser											
Quantity of coils	#	1	1	1	1	1	2	2	2	2	2
Coil length	(mm)	2311	2311	2311	3226	3226	2311	2311	2311	3226	3226
Coil height/circuit ¹	(mm)	1727	1727	1727	1727	1727	1727	1727	1727	1727	1727
Number of rows	#	2	2	2	2	2	2	2	2	2	2
Fins per foot	(fpf)	192	192	192	192	192	192	192	192	192	192
Fan											
Quantity	#	2	2	2	3	3	4	4	4	6	6
Diameter	(mm)	757	757	757	757	757	757	757	757	757	757
Airflow per fan	(m ³ /h)	13341	13344	13347	13129	13133	13341	13344	13347	13129	13133
Power per motor	(kW)	0.8	0.8	0.8	0.8	0.8	0.8	0.8	0.8	0.8	0.8
Motor RPM	(rpm)	920	920	920	920	920	920	920	920	920	920
Tip Speed	(m/s)	36	36	36	36	36	36	36	36	36	36
General Unit											
Refrigerant circuit	#	1	1	1	1	1	2	2	2	2	2
Capacity steps	%	50-100	43-100	50-100	50-100	43-100	25-50-75-100	21-43-72-100	25-50-75-100	25-50-75-100	21-43-71-100
Refrig charge/circuit ¹	(kg)	14.5	14.5	15.4	21.8	21.8	14.5	14.5	14.5	21.8	22.7
Oil charge/circuit ¹	(l)	6.6	6.6	6.6	13.4	13.4	6.6	6.6	6.6	13.4	13.4
Min ambient											
High ambient	(°C)	7	7	7	3	3	7	7	7	3	3
Wide ambient	(°C)	-18	-18	-18	-18	-18	-18	-18	-18	-18	-18

1. Data shown for circuit one only. The second circuits always matches.

2. Flow limits are for water only.

Table 2. General Data - CGAM - Compact Units - 80-160 ton

Size		80	90	100	110	120	140	150	160
Compressor									
Number	#	4	4	4	4	4	6	6	6
Tonnage/circuit ¹		20+20	20+25	25+25	25+30	30+30	20+25+25	25+25+25	25+25+30
Evaporator									
Water storage	(l)	26.5	34.1	39.2	43.4	43.4	46.7	46.7	46.7
Minimum flow ²	(l/s)	5.4	6.1	6.9	7.4	7.9	9.3	10.0	10.5
Maximum flow ¹	(l/s)	16.3	18.3	20.6	22.3	23.8	27.9	30.0	31.5
Water connection	(mm)	100	100	100	100	100	100	100	100
Pump Package									
Evap head pressure avail - high head	(kPa)	217.6	214.8	200.3	188.7	224.3	189.9	172.1	215.0
Power - high head	(kW)	7.5	7.5	7.5	7.5	11	11	11	15
Expansion tank volume	(l)	50	50	50	50	50	50	50	50
Expansion tank capacity	(l)	1300	1300	1300	1300	1300	1300	1300	1300
Buffer tank volume	(l)	592	592	762	762	762	762	762	762
Condenser									
Quantity of coils	#	4	4	4	4	4	4	4	4
Coil length	(mm)	3073	3073	3658	3658	3658	4572	5486	5486
Coil height/circuit ¹	(mm)	2134	2134	2134	2134	2134	2134	2134	2134
Number of rows	#	3	3	3	3	3	3	3	3
Fins per foot	(fpf)	192	192	192	192	192	192	192	192
Fan									
Quantity	#	6	6	8	8	8	10	12	12
Diameter	(mm)	757	757	757	757	757	757	757	757
Airflow per fan	(m ³ /h)	13158	13162	12794	12796	12799	12796	12793	12795
Power per motor	(kW)	0.8	0.8	0.8	0.8	0.8	0.8	0.8	0.8
Motor RPM	(rpm)	920	920	920	920	920	920	920	920
Tip Speed	(m/s)	36	36	36	36	36	36	36	36
General Unit									
Refrigerant circuit	#	2	2	2	2	2	2	2	2
Capacity steps	%	25-50-75-100	22-44-72-100	25-50-75-100	23-45-73-100	25-50-75-100	14-29-46-64-82-100	17-33-50-67-83-100	16-31-47-63-81-100
Refrig charge/circuit ¹	(kg)	33.6	33.6	37.2	38.1	38.1	50.8	58.1	59.0
Oil charge/circuit ¹	(l)	13.4	13.4	13.4	13.9	14.4	22.5	23.0	23.5
Min ambient									
High ambient	(°C)	3	3	0	0	0	0	0	0
Wide ambient	(°C)	-18	-18	-18	-18	-18	-18	-18	-18

1. Data shown for circuit one only. The second circuits always matches.

2. Flow limits are for water only.



General Data

Table 3. General Data - CGAM - Comprehensive Acoustic Package Units - 20-70 ton

Size		20	23	26	30	35	40	46	52	60	70
Compressor											
Number	#	2	2	2	2	2	4	4	4	4	4
Tonnage/circuit ¹		10+10	10+13	13+13	15+15	15+20	10+10	10+13	13+13	15+15	15+20
Evaporator											
Water storage	(l)	5.3	8.2	6.3	6.3	10.6	14.3	14.3	15.6	18.9	28.2
Minimum flow ²	(l/s)	1.4	1.6	1.8	1.9	2.2	2.7	3.0	3.5	3.9	4.5
Maximum flow ¹	(l/s)	4.1	4.7	5.3	5.7	6.7	8.0	8.9	10.6	11.7	13.6
Water connection	(mm)	50	50	65	65	65	65	65	80	80	80
Pump Package											
Evap head pressure avail - high head	(kPa)	286.3	264.3	233.5	237.1	247.7	230.8	206.1	180.4	218.0	214.3
Power - high head	(kW)	4	4	4	4	5.5	5.5	5.5	5.5	7.5	7.5
Expansion tank volume	(l)	24	24	24	24	24	24	24	24	24	24
Expansion tank capacity	(l)	350	350	350	350	350	350	350	350	350	350
Buffer tank volume	(l)	542	542	542	542	542	515	515	515	515	515
Condenser											
Quantity of coils	#	1	1	1	1	1	2	2	2	2	2
Coil length	(mm)	2311	2311	2769	3226	3226	2311	2311	2769	3226	3226
Coil height/circuit ¹	(mm)	1727	1727	1727	1727	1727	1727	1727	1727	1727	1727
Number of rows	#	2	2	2	2	2	2	2	2	2	2
Fins per foot	(fpf)	192	192	192	192	192	192	192	192	192	192
Fan											
Quantity	#	2	2	3	3	3	4	4	6	6	6
Diameter	(mm)	757	757	757	757	757	757	757	757	757	757
Airflow per fan	(m ³ /h)	10077	10081	9500	9909	9913	10077	10080	9500	9909	9913
Power per motor	(kW)	0.4	0.4	0.4	0.4	0.4	0.4	0.4	0.4	0.4	0.4
Motor RPM	(rpm)	700	700	700	700	700	700	700	700	700	700
Tip speed	(m/s)	28	28	28	28	28	28	28	28	28	28
General Unit											
Refrigerant circuit	#	1	1	1	1	1	2	2	2	2	2
Capacity steps	%	50-100	43-100	50-100	50-100	43-100	25-50-75-100	21-43-72-100	25-50-75-100	25-50-75-100	21-43-71-100
Refrig charge/circuit ¹	(kg)	14.5	14.5	19.1	21.8	21.8	14.5	14.5	19.1	21.8	21.8
Oil charge/circuit ¹	(l)	6.6	6.6	6.6	13.4	13.4	6.6	6.6	6.6	13.4	13.4
Min ambient											
High ambient	(°C)	7	7	3	3	3	7	7	3	3	3
Wide ambient	(°C)	-18	-18	-18	-18	-18	-18	-18	-18	-18	-18

1. Data shown for circuit one only. The second circuits always matches.

2. Flow limits are for water only.

Table 4. General Data - CGAM - Comprehensive Acoustic Package Units - 80-160 ton

Size		80	90	100	110	120	140	150	160
Compressor									
Number	#	2	2	2	2	2	4	4	4
Tonnage/circuit ¹		20+20	20+25	25+25	25+30	30+30	20+25+25	25+25+25	25+25+30
Evaporator									
Water storage	(l)	28.2	34.1	39.2	39.2	43.4	46.7	46.7	46.7
Minimum flow ²	(l/s)	5.4	6.1	6.7	7.2	7.9	9.3	9.8	10.3
Maximum flow ¹	(l/s)	16.2	18.3	20.2	21.7	23.7	27.9	29.4	30.8
Water connection	(mm)	100	100	100	100	100	100	100	100
Pump Package									
Evap head pressure avail - high head	(kPa)	223.4	214.1	204.5	190.2	224.9	190.3	177.5	221.6
Power - high head	(kW)	7.5	7.5	7.5	7.5	11	11	11	15
Expansion tank volume	(l)	50	50	50	50	50	50	50	50
Expansion tank capacity	(l)	1300	1300	1300	1300	1300	1300	1300	1300
Buffer tank volume	(l)	762	762	762	762	762	762	762	762
Condenser									
Quantity of coils	#	4	4	4	4	4	4	4	4
Coil length	(mm)	3658	3658	3658	4572	4572	5486	5486	5486
Coil height/circuit ¹	(mm)	2134	2134	2134	2134	2134	2134	2134	2134
Number of rows	#	3	3	3	3	3	3	3	3
Fins per foot	(fpf)	192	192	192	192	192	192	192	192
Fan									
Quantity	#	6	8	8	8	10	12	12	12
Diameter	(mm)	757	757	757	757	757	757	757	757
Airflow per fan	(m ³ /h)	10291	9626	9629	10163	9627	9627	9628	9630
Power per motor	(kW)	0.3	0.4	0.4	0.3	0.4	0.4	0.4	0.4
Motor RPM	(rpm)	700	700	700	700	700	700	700	700
Tip speed	(m/s)	28	28	28	28	28	28	28	28
General Unit									
Refrigerant circuit	#	2	2	2	2	2	2	2	2
Capacity steps	%	25-50-75-100	22-44-72-100	25-50-75-100	23-45-73-100	25-50-75-100	14-29-46-64-82-100	17-33-50-67-83-100	16-31-47-63-81-100
Refrig charge/circuit ¹	(kg)	36.3	36.3	37.2	44.5	45.4	58.1	58.1	59.0
Oil charge/circuit ¹	(l)	13.4	13.4	13.4	13.9	14.4	22.5	23.0	23.5
Min ambient									
High ambient	(°C)	3	0	0	0	0	0	0	0
Wide ambient	(°C)	-18	-18	-18	-18	-18	-18	-18	-18

1. Data shown for circuit one only. The second circuits always matches.

2. Flow limits are for water only.



General Data

Table 5. General Data - CXAM - Compact Units - 20-70 ton

Size		20	23	26	30	35	40	46	52	60	70
Compressor											
Number	#	2	2	2	2	2	4	4	4	4	4
Tonnage/circuit ¹		10+10	10+13	13+13	15+15	15+20	10+10	10+13	13+13	15+15	15+20
Brazed Plate Heat Exchanger											
Water storage	(l)	6.7	6.7	8.2	6.3	10.6	14.3	14.3	15.6	15.6	28.2
Min. flow ²	(l/s)	1.4	1.5	1.8	1.9	2.2	2.6	2.9	3.5	3.8	4.5
Max. flow ¹	(l/s)	4.1	4.5	5.3	5.7	6.6	7.8	8.7	10.4	11.4	13.4
Water connection	(mm)	50	50	65	65	65	65	65	80	80	80
Pump Package											
Evap head pressure avail - high head	(kPa)	289.5	262.2	248.8	238.5	249.3	234.4	212.6	183.3	207.4	215.5
Power - high head	(kW)	4	4	4	4	5.5	5.5	5.5	5.5	7.5	7.5
Expansion tank volume	(l)	24	24	24	24	24	24	24	24	24	24
Expansion tank capacity	(l)	50	50	50	50	50	50	50	50	50	50
Buffer tank volume	(l)	534.4	534.4	534.4	534.4	534.4	505.4	505.4	505.4	505.4	505.4
Air-Cooled Coil											
Quantity of coils	#	1	1	1	1	1	2	2	2	2	2
Coil length	(mm)	2311	2311	2769	3226	3226	2311	2311	2769	3226	3226
Coil height/circuit ¹	(mm)	1727	1727	1727	1727	1727	1727	1727	1727	1727	1727
Number of rows	#	3	3	3	3	3	3	3	3	3	3
Fins per foot	(fpf)	192	192	192	192	192	192	192	192	192	192
Fan											
Quantity	#	2	2	3	3	3	4	4	6	6	6
Diameter	(mm)	757	757	757	757	757	757	757	757	757	757
Airflow per fan	(m ³ /h)	13060	13062	12250	12823	12827	13059	13061	12250	12823	12827
Power per motor	(kW)	0.8	0.8	0.9	0.8	0.8	0.8	0.8	0.9	0.8	0.8
Motor RPM	(rpm)	920	920	920	920	920	920	920	920	920	920
Tip speed	(m/s)	36	36	36	36	36	36	36	36	36	36
General Unit											
Refrigerant circuit	#	1	1	1	1	1	2	2	2	2	2
Capacity steps	%	50-100	43-100	50-100	50-100	43-100	25-50-75-100	21-43-71-100	25-50-75-100	25-50-75-100	21-43-71-100
Refrig charge/circuit ¹	(kg)	22.7	22.7	29.0	33.6	33.6	22.7	22.7	29.0	32.7	32.7
Oil charge/circuit ¹	(l)	6.6	6.6	6.6	13.4	13.4	6.6	6.6	6.6	13.4	13.4
Min ambient											
Std ambient (cooling)	(°C)	7	7	3	3	3	7	7	3	3	3
Std ambient (heating)	(°C)	-10	-10	-10	-10	-10	-10	-10	-10	-10	-10

1. Data shown for circuit one only. The second circuits always matches.

2. Flow limits are for water only.

Table 6. General Data - CXAM - Compact Units - 80-160 ton

Size		80	90	100	110	120	140	150	160
Compressor									
Number	#	4	4	4	4	4	6	6	6
Tonnage/circuit ¹		20+20	20+25	25+25	25+30	30+30	20+25+25	25+25+25	25+25+30
Brazed Plate Heat Exchanger									
Water storage	(l)	32.4	40.8	46.7	40.8	43.4	46.7	46.7	46.7
Min. flow ²	(l/s)	5.4	5.9	6.8	7.2	7.7	8.8	9.4	9.8
Max. flow ¹	(l/s)	16.1	17.8	20.4	21.7	23.2	26.4	28.1	29.5
Water connection	(mm)	100	100	100	100	100	100	100	100
Pump Package									
Evap head pressure avail - high head	(kPa)	229.0	225.6	203.6	193.2	228.8	201.8	188.6	232.6
Power - high head	(kW)	7.5	7.5	7.5	7.5	11	11	11	11
Expansion tank volume	(l)	50	50	50	50	50	50	50	50
Expansion tank capacity	(l)	900	900	900	900	900	900	900	900
Buffer tank volume	(l)	744	744	744	744	744	744	744	744
Air-Cooled Coil									
Quantity of coils	#	4	4	4	4	4	4	4	4
Coil length	(mm)	3658	3658	4572	4572	4572	5486	5486	5486
Coil height/circuit ¹	(mm)	2134	2134	2134	2134	2134	2134	2134	2134
Number of rows	#	3	3	3	3	3	3	3	3
Fins per foot	(fpf)	192	192	192	192	192	192	192	192
Fan									
Quantity	#	8	8	10	10	10	12	12	12
Diameter	(mm)	757	757	757	757	757	757	757	757
Airflow per fan	(m ³ /h)	13012	13015	13013	13014	13016	13015	13017	13018
Power per motor	(kW)	0.8	0.8	0.8	0.8	0.8	0.8	0.8	0.8
Motor RPM	(rpm)	920	920	920	920	920	920	920	920
Tip speed	(m/s)	36	36	36	36	36	36	36	36
General Unit									
Refrigerant circuit	#	2	2	2	2	2	3	3	3
Capacity steps	%	25-50-75-100	22-44-72-100	25-50-75-100	23-45-73-100	25-50-75-100	14-29-46-64-82-100	17-33-50-67-83-100	16-31-47-63-81-100
Refrig charge/circuit ¹	(kg)	45.4	49.0	59.2	59.0	59.0	72.0	72.0	72.0
Oil charge/circuit ¹	(l)	13.4	13.4	13.4	13.9	14.4	22.5	23.0	23.5
Min ambient									
Std ambient (cooling)	(°C)	0	0	0	0	0	0	0	0
Std ambient (heating)	(°C)	-10	-10	-10	-10	-10	-10	-10	-10

1. Data shown for circuit one only. The second circuits always matches.

2. Flow limits are for water only.



General Data

Table 7. General Data - CXAM - Comprehensive Acoustic Package Units - 20-70 ton

Size		20	23	26	30	35	40	46	52	60	70
Compressor											
Number	#	2	2	2	2	2	4	4	4	4	4
Tonnage/circuit ¹		10+10	10+13	13+13	15+15	15+20	10+10	10+13	13+13	15+15	15+20
Brazed Plate Heat Exchanger											
Water storage	(l)	6.7	6.7	8.2	6.3	10.6	14.3	14.3	15.6	15.6	28.2
Min. flow ²	(l/s)	1.3	1.5	1.7	1.9	2.1	2.5	3.0	3.4	3.7	4.3
Max. flow ¹	(l/s)	3.9	4.5	5.1	5.6	6.4	7.6	9.0	10.2	11.1	12.9
Water connection	(mm)	50	65	65	65	65	65	80	80	80	80
Pump Package											
Evap head pressure avail - high head	(kPa)	291.0	258.4	237.7	258.9	253.9	236.5	219.7	186.8	211.3	220.1
Power - high head	(kW)	4	4	4	4	5.5	5.5	5.5	5.5	7.5	7.5
Expansion tank volume	(l)	24	24	24	24	24	24	24	24	24	24
Expansion tank capacity	(l)	50	50	50	50	50	50	50	50	50	50
Buffer tank volume	(l)	534.4	534.4	534.4	534.4	534.4	505.4	505.4	505.4	505.4	505.4
Air-Cooled Coil											
Quantity of coils	#	1	1	1	1	1	2	2	2	2	2
Coil length	(mm)	2311	2769	3226	3226	3226	2311	2769	3226	3226	3226
Coil height/circuit ¹	(mm)	1727	1727	1727	1727	1727	1727	1727	1727	1727	1727
Number of rows	#	3	3	3	3	3	3	3	3	3	3
Fins per foot	(fpf)	192	192	192	192	192	192	192	192	192	192
Fan											
Quantity	#	2	3	3	3	3	4	6	6	6	6
Diameter	(mm)	757	757	757	757	757	757	757	757	757	757
Airflow per fan	(m ³ /h)	9846	9201	9656	9658	9662	9845	9201	9656	9658	9662
Power per motor	(kW)	0.4	0.4	0.4	0.4	0.4	0.4	0.4	0.4	0.4	0.4
Motor RPM	(rpm)	700	700	700	700	700	700	700	700	700	700
Tip speed	(m/s)	28	28	28	28	28	28	28	28	28	28
General Unit											
Refrigerant circuit	#	1	1	1	1	1	2	2	2	2	2
Capacity steps	%	50-100	43-100	50-100	50-100	43-100	25-50-75-100	21-43-71-100	25-50-75-100	25-50-75-100	21-43-71-100
Refrig charge/circuit ¹	(kg)	22.7	29.9	33.6	33.6	33.6	22.7	29.9	33.6	34.5	34.5
Oil charge/circuit ¹	(l)	6.6	6.6	6.6	13.4	13.4	6.6	6.6	6.6	13.4	13.4
Min ambient											
Std ambient (cooling)	(°C)	7	3	3	3	3	7	3	3	3	3
Std ambient (heating)	(°C)	-10	-10	-10	-10	-10	-10	-10	-10	-10	-10

1. Data shown for circuit one only. The second circuits always matches.

2. Flow limits are for water only.

Table 8. General Data - CXAM - Comprehensive Acoustic Package Units - 80-120 ton

Size		80	90	100	110	120
Compressor						
	Number #	4	4	4	4	4
	Tonnage/circuit ¹	20+20	20+25	25+25	25+30	30+30
Brazed Plate Heat Exchanger						
	Water storage (l)	39.2	39.2	46.7	43.4	46.7
	Min. flow ² (l/s)	5.2	5.8	6.6	7.2	7.7
	Max. flow ¹ (l/s)	15.7	17.5	19.9	21.7	23.2
	Water connection (mm)	100	100	100	100	100
Pump Package						
	Evap head pressure avail - high head (kPa)	237.7	227.6	208.0	195.8	226.1
	Power - high head (kW)	7.5	7.5	7.5	7.5	11
	Expansion tank volume (l)	50	50	50	50	50
	Expansion tank capacity (l)	900	900	900	900	900
	Buffer tank volume (l)	744	744	744	744	744
Air-Cooled Coil						
	Quantity of coils #	4	4	4	4	4
	Coil length (mm)	3658	4572	4572	5486	5486
	Coil height/circuit ¹ (mm)	2134	2134	2134	2134	2134
	Number of rows #	3	3	3	3	3
	Fins per foot (fpf)	192	192	192	192	192
Fan						
	Quantity #	8	8	10	12	12
	Diameter (mm)	757	757	757	757	757
	Airflow per fan (m ³ /h)	9807	10301	9807	9805	9807
	Power per motor (kW)	0.4	0.3	0.4	0.4	0.4
	Motor RPM (rpm)	700	700	700	700	700
	Tip speed (m/s)	28	28	28	28	28
General Unit						
	Refrigerant circuit #	2	2	2	2	2
	Capacity steps %	25-50-75-100	22-44-72-100	25-50-75-100	23-45-73-100	25-50-75-100
	Refrig charge/circuit ¹ (kg)	45.4	54.4	56.2	66.2	66.2
	Oil charge/circuit ¹ (l)	13.4	13.4	13.4	13.9	14.4
Min ambient						
	Std ambient (cooling) (°C)	0	0	0	0	0
	Std ambient (heating) (°C)	-10	-10	-10	-10	-10

1. Data shown for circuit one only. The second circuits always matches.

2. Flow limits are for water only.



Controls

LCD Touch-Screen Display with Multi-Language Support

The standard DynaView display provided with the Trane CH530 control panel features an LCD touch-screen that is navigated by file tabs. This is an advanced interface that allows the user to access any important information concerning setpoints, active temperatures, modes, electrical data, pressure, and diagnostics. It uses full text display available in 19 languages.

Display Features Include:

- LCD touch-screen with LED backlighting, for scrolling access to input and output operating information
- Single-screen, folder/tab-style display of all available information on individual components (evaporator, condenser, compressor, etc.)
- Password entry/lockout system to enable or disable display
- Automatic and immediate stop capabilities for standard or immediate manual shutdown
- Fast, easy access to available chiller data in tabbed format, including:
 - Modes of operation, including normal cooling and heating as well as ice making
 - Water temperatures and setpoints
 - Loading and limiting status and setpoints
 - Outdoor air temperature
 - Start/stop differential timers
 - Pump status and override
 - Chilled and hot water reset settings
- Optional external setpoints, including:
 - Chilled and hot water, demand limit, ice building

Reports, listed on a single tabbed screen for easy access, including:

- ASHRAE, containing all guideline 3 report information
- Evaporator, condenser, compressor

Evaporator, condenser, and compressor reports containing all operational information on individual components, including:

- Water temperatures, refrigerant pressures, temperatures, and approach
- Flow switch status, EXV position, compressor starts and run-time

Alarm and diagnostic information, including:

- Flashing alarms with touch-screen button for immediate address of alarm condition
- Scrollable list of last ten active diagnostics
- Specific information on applicable diagnostic from list of over one-hundred
- Automatic or manual resetting diagnostic types

Adaptive Controls

Adaptive Controls directly sense the control variables that govern the operation of the chiller: evaporator pressure and condenser pressure. When any one of these variables approaches a limit condition when damage may occur to the unit or shutdown on a safety, Adaptive Controls takes corrective action to avoid shutdown and keep the chiller operating. This happens through combined actions of compressor and/or fan staging. Whenever possible, the chiller is allowed to continue making chilled or hot water. This keeps cooling capacity available until the problem can be solved. Overall, the safety controls help keep the building or process running and out of trouble.

Stand-Alone Controls

Single chillers installed in applications without a building management system is simple to install and control: only a remote auto/stop for scheduling is required for unit operation. Signals from the chilled-water pump contactor auxiliary, or a flow switch, are wired to the chilled-water flow interlock. Signals from a time clock or some other remote device are wired to the external auto/stop input.

- Auto/Stop - A job-site provided contact closure turns the unit on and off.
- External Interlock - A job-site provided contact opening wired to this input turns the unit off and requires a manual reset of the unit microcomputer. This closure is typically triggered by a job-site provided system such as a fire alarm.

Time of Day Scheduling

Time of day scheduling allows the customer to perform simple chiller scheduling without the need for a building automation system.

This feature allows the user to set ten events in a seven day time period. For each event the user can specify an activation time and the days of the week the event is active. Any available setpoints can be specified for each event, such as the leaving chilled water temperature (standard) and the demand limit setpoint (optional if ordered).

Required features:

- Time of day scheduling (selectable option with chiller)

Additional options that if ordered may be incorporated into the scheduling:

- External chilled or hot water setpoint, external demand limit setpoint
- Ice-making initiation

Hardwire Points

Microcomputer controls allow simple interface with other control systems, such as time clocks, building automation systems, and ice storage systems via hardwire points. This means you have the flexibility to meet job requirements while not having to learn a complicated control system.

Remote devices are wired from the control panel to provide auxiliary control to a building automation system. Inputs and outputs can be communicated via a typical 4–20 mA electrical signal, an equivalent 2–10 Vdc signal, or by utilizing contact closures.

This setup has the same features as a stand-alone water chiller, with the possibility of having additional optional features:

- Ice making control
- External chilled or hot water setpoint, external demand limit setpoint
- Chilled water temperature reset
- Programmable relays - available outputs are: alarm-latching, alarm-auto reset, general alarm, warning, chiller limit mode, compressor running, and Tracer control

LonTalk LCI-C Interface with Modbus Interface

LonTalk (LCI-C) with ModBus communications capabilities are available, with communication link via single twisted-pair wiring to factory-installed, tested communication board.

Required features:

- LonTalk LC I-C Interface w/ Modbus Interface
- Protocol Interface Controller

Modbus is a messaging structure developed by Modicon to transfer and register data between control devices. Modbus is a membership-based trade association that seeks to drive the adoption of the Modbus communication protocol as the messaging structure that devices support. Modbus is a system level communications protocol.

BACnet Interface

BACnet interface capabilities are available, with communication link via single twisted-pair wiring to a factory-installed and tested communication board.

Required features:

- BACnet Interface (selectable option with chiller)

BACnet is a data communication protocol for building automation and control networks developed by American Society of Heating, Refrigerating and Air-Conditioning Engineers (ASHRAE).

LonTalk LCI-C Interface

LonTalk (LCI-C) communications capabilities are available, with communication link via single twisted-pair wiring to factory-installed, tested communication board.

Required features:

- LonTalk/Tracer Summit Interface (selectable option with chiller)

LonTalk is a communications protocol developed by the Echelon Corporation. The LonMark association develops control profiles using the LonTalk communication protocol. LonTalk is a unit level communications protocol.

LonTalk Communications Interface for Chillers (LCI-C) provides a generic automation system with the LonMark chiller profile inputs/outputs. In addition to the standard points, Trane provides other commonly used network output variables for greater interoperability with any automation system. The complete reference list of Trane LonTalk points is available on the LonMark web site.

Trane controls or another vendor's system can use the predefined list of points with ease to give the operator a complete picture of how the system is running

Tracer Summit

The chiller plant control capabilities of the Trane Tracer Summit building automation system are unequalled in the industry. Trane's depth of experience in chillers and controls makes us a well-qualified choice for automation of chiller plants using air-cooled AquaStream chillers. Our chiller plant automation software is fully pre-engineered and tested.

Required features:

- LonTalk/Tracer Summit Interface (selectable option with chiller)
- Building Control Unit (external device required)

Energy Efficiency

- Sequences starting of chillers to optimize the overall chiller plant energy efficiency
 - Individual chillers operate as base, peak, or swing based on capacity and efficiency
 - Automatically rotates individual chiller operation to equalize runtime and wear between chillers.
 - Evaluates and selects the lowest energy consumption alternative from an overall system perspective.

Easy Operation and Maintenance

- Remote monitoring and control
- Displays both current operation conditions and scheduled automated control actions
- Concise reports assist in planning for preventative maintenance and verifying performance
- Alarm notification and diagnostic messages aid in quick and accurate troubleshooting

When integrated with a Tracer Summit building management system the total building operation can be optimized. With this system option, the full breadth of Trane's HVAC and controls experience are applied to offer solutions to many facility issues. If your project calls for an interface to other systems, Tracer Summit can share data via Modbus or BACnet open systems protocols.



Electrical Data

Table 1. Electrical Data - CGAM

Size	Power	Noise	Compressor Motor		Cond Fan	Field Wiring				Ring Size
			RLA	LRA	FLA	Without Pump	High Head Pump			
						MCA	MOPD	MCA	MOPD	
20	380/50/3	Compact	19-19	130-130	2.6	49	63	57	63	FOT16-8
	400/50/3		19-19	130-130	2.6	49	63	56	63	FOT16-8
	380/50/3	Comprehensive	19-19	130-130	1.9	47	63	55	63	FOT16-8
	400/50/3		19-19	130-130	1.9	47	63	55	63	FOT16-8
23	380/50/3	Compact	19-22	130-158	2.6	54	63	62	80	FOT16-8
	400/50/3		19-22	130-158	2.6	54	63	61	80	FOT16-8
	380/50/3	Comprehensive	19-22	130-158	1.9	52	63	60	80	FOT16-8
	400/50/3		19-22	130-158	1.9	52	63	60	80	FOT16-8
26	380/50/3	Compact	22-22	158-158	2.6	58	63	66	80	FOT16-8
	400/50/3		22-22	158-158	2.6	57	63	65	80	FOT16-8
	380/50/3	Comprehensive	22-22	158-158	1.9	57	63	65	80	FOT16-8
	400/50/3		22-22	158-158	1.9	57	63	65	80	FOT16-8
30	380/50/3	Compact	28-28	160-160	2.6	72	100	80	100	FOT25-8
	400/50/3		27-27	160-160	2.6	69	80	77	100	FOT25-8
	380/50/3	Comprehensive	28-28	160-160	1.9	70	80	78	100	FOT25-8
	400/50/3		27-27	160-160	1.9	66	80	74	100	FOT25-8
35	380/50/3	Compact	28-35	160-215	2.6	81	100	92	125	FOT35-8
	400/50/3		27-33	160-215	2.6	78	100	88	100	FOT35-8
	380/50/3	Comprehensive	28-35	160-215	1.9	79	100	90	100	FOT35-8
	400/50/3		27-33	160-215	1.9	75	100	85	100	FOT25-8
40	380/50/3	Compact	19-19/19-19	130-130/130-130	2.6	91	100	102	100	FOT35-8
	400/50/3		19-19/19-19	130-130/130-130	2.6	91	100	102	100	FOT35-8
	380/50/3	Comprehensive	19-19/19-19	130-130/130-130	1.9	88	100	99	100	FOT35-8
	400/50/3		19-19/19-19	130-130/130-130	1.9	88	100	98	100	FOT35-8
46	380/50/3	Compact	19-22/22-19	130-158/158-130	2.6	100	100	111	125	FOT50-10
	400/50/3		19-22/22-19	130-158/158-130	2.6	100	100	110	125	FOT50-10
	380/50/3	Comprehensive	19-22/22-19	130-158/158-130	1.9	96	100	108	125	FOT35-8
	400/50/3		19-22/22-19	130-158/158-130	1.9	96	100	107	125	FOT35-8
52	380/50/3	Compact	22-22/22-22	158-158/158-158	2.6	107	125	119	125	FOT50-10
	400/50/3		22-22/22-22	158-158/158-158	2.6	107	125	118	125	FOT50-10
	380/50/3	Comprehensive	22-22/22-22	158-158/158-158	1.9	107	125	118	125	FOT50-10
	400/50/3		22-22/22-22	158-158/158-158	1.9	106	125	117	125	FOT50-10
60	380/50/3	Compact	28-28/28-28	160-160/160-160	2.6	136	160	150	160	FOT70-10
	400/50/3		27-27/27-27	160-160/160-160	2.6	130	125	143	160	FOT70-10
	380/50/3	Comprehensive	28-28/28-28	160-160/160-160	1.9	130	125	145	160	FOT70-10
	400/50/3		27-27/27-27	160-160/160-160	1.9	124	125	138	160	FOT70-10
70	380/50/3	Compact	28-28/28-28	160-215/215-160	2.6	152	160	166	200	FOT70-10
	400/50/3		27-27/27-27	160-215/215-160	2.6	145	160	158	160	FOT70-10
	380/50/3	Comprehensive	28-28/28-28	160-215/215-160	1.9	146	160	161	160	FOT70-10
	400/50/3		27-27/27-27	160-215/215-160	1.9	139	160	153	160	FOT70-10

Table 1. Electrical Data - CGAM

Size	Power	Noise	Compressor Motor		Cond	Field Wiring				Ring Size
			RLA	LRA	Fan FLA	Without Pump MCA	MOPD	High Head Pump MCA	MOPD	
80	380/50/3	Compact	35-35/35-35	215-215/215-215	2.6	166	200	180	200	FOT95-10
	400/50/3		33-33/33-33	215-215/215-215	2.6	158	160	172	200	FOT70-10
	380/50/3	Comprehensive Acoustic	35-35/35-35	215-215/215-215	1.9	160	160	175	200	FOT95-10
	400/50/3		33-33/33-33	215-215/215-215	1.9	153	160	166	160	FOT70-10
90	380/50/3	Compact	35-46/46-35	215-260/260-215	2.6	190	200	205	250	FOT95-10
	400/50/3		33-44/44-33	215-260/260-215	2.6	181	200	195	200	FOT95-10
	380/50/3	Comprehensive Acoustic	35-46/46-35	215-260/260-215	1.9	188	200	202	200	FOT95-10
	400/50/3		33-44/44-33	215-260/260-215	1.9	179	200	192	200	FOT95-10
100	380/50/3	Compact	46-46/46-46	260-260/260-260	2.6	217	250	231	250	FOT120-12
	400/50/3		44-44/44-44	260-260/260-260	2.6	207	250	221	250	FOT120-12
	380/50/3	Comprehensive Acoustic	46-46/46-46	260-260/260-260	1.9	209	250	224	250	FOT120-12
	400/50/3		44-44/44-44	260-260/260-260	1.9	199	200	213	250	FOT120-12
110	380/50/3	Compact	46-51/51-46	260-320/320-260	2.6	227	250	242	250	FOT150-12
	400/50/3		44-51/51-44	260-320/320-260	2.6	222	250	236	250	FOT120-12
	380/50/3	Comprehensive Acoustic	46-51/51-46	260-320/320-260	1.9	220	250	235	250	FOT120-12
	400/50/3		44-51/51-44	260-320/320-260	1.9	215	250	229	250	FOT120-12
120	380/50/3	Compact	51-51/51-51	320-320/320-320	2.6	237	250	257	300	FOT150-12
	400/50/3		51-51/51-51	320-320/320-320	2.6	236	250	256	300	FOT150-12
	380/50/3	Comprehensive Acoustic	51-51/51-51	320-320/320-320	1.9	232	250	253	300	FOT150-12
	400/50/3		51-51/51-51	320-320/320-320	1.9	231	250	251	300	FOT150-12
140	380/50/3	Compact	46-35-46/46-35-46	260-215-260/260-215-260	2.6	292	315	312	350	FOT240-14
	400/50/3		44-34-44/44-34-44	260-215-260/260-215-260	2.6	278	315	298	315	FOT185-12
	380/50/3	Comprehensive Acoustic	46-35-46/46-35-46	260-215-260/260-215-260	1.9	285	315	306	350	FOT185-12
	400/50/3		44-34-44/44-34-44	260-215-260/260-215-260	1.9	271	315	291	315	FOT185-12
150	380/50/3	Compact	46-46-46/46-46-46	260-260-260/260-260-260	2.6	318	350	339	350	FOT240-14
	400/50/3		44-44-44/44-44-44	260-260-260/260-260-260	2.6	303	315	323	350	FOT240-14
	380/50/3	Comprehensive Acoustic	46-46-46/46-46-46	260-260-260/260-260-260	1.9	307	350	327	350	FOT240-14
	400/50/3		44-44-44/44-44-44	260-260-260/260-260-260	1.9	292	315	312	350	FOT185-12
160	380/50/3	Compact	46-46-51/51-46-46	260-260-320/320-260-260	2.6	329	350	357	400	FOT240-14
	400/50/3		44-44-51/51-44-44	260-260-320/320-260-260	2.6	319	350	345	350	FOT240-14
	380/50/3	Comprehensive Acoustic	46-46-51/51-46-46	260-260-320/320-260-260	1.9	317	350	345	350	FOT240-14
	400/50/3		44-44-51/51-44-44	260-260-320/320-260-260	1.9	308	350	334	350	FOT240-14

1. Circuit 1/circuit 2
2. RLA - Rated Load Amps
3. LRA - Locked Rotor Amps - Based on full winding starts.
4. MCA - Minimum Circuit Ampacity-125 percent of largest compressor RLA plus 100 percent of all other loads.
5. MOPD or Max Fuse -225 percent of the largest compressor RLA plus 100 percent of all other loads.
6. Voltage Utilization Range:
Rated voltage (use range): 400/50/3 (360-440)
7. One separate 120/50/1, 15 amp customer provided power connection is required to power the heaters. An additional 120/50/1, 15 amp customer provided power connection is required if the optional buffer tank is selected.
8. Local codes may take precedence.
9. Copper wire only, based on nameplate Minimum Circuit Ampacity (MCA).



Electrical Data

Table 2. Electrical Data - CXAM

Size	Volts	Noise	Compressor Motor		Field Wring					Ring Size
			RLA	LRA	Fan FLA	Without Pump MCA	MOPD	High Head Pump MCA	MOPD	
020	380/50/3	Compact	19-19	130-130	2.4	49	63	57	63	FOT16-8
	400/50/3		19-19	130-130	2.3	49	63	56	63	FOT16-8
	380/50/3	Comprehensive Acoustic	19-19	130-130	1.4	47	63	55	63	FOT16-8
	400/50/3		19-19	130-130	1.3	47	63	55	63	FOT16-8
023	380/50/3	Compact	19-19	130-130	2.4	54	63	62	80	FOT16-8
	400/50/3		19-19	130-130	2.3	54	63	61	80	FOT16-8
	380/50/3	Comprehensive Acoustic	19-19	130-130	1.4	54	63	62	80	FOT16-8
	400/50/3		19-19	130-130	1.3	53	63	61	80	FOT16-8
026	380/50/3	Compact	22-22	158-158	2.4	60	80	68	80	FOT16-8
	400/50/3		22-22	158-158	2.3	60	80	67	80	FOT16-8
	380/50/3	Comprehensive Acoustic	22-22	158-158	1.4	57	63	65	80	FOT16-8
	400/50/3		22-22	158-158	1.3	57	63	65	80	FOT16-8
030	380/50/3	Compact	28-28	160-160	2.4	72	100	80	100	FOT25-8
	400/50/3		27-27	160-160	2.3	69	80	77	100	FOT25-8
	380/50/3	Comprehensive Acoustic	28-28	160-160	1.4	70	80	78	100	FOT25-8
	400/50/3		27-27	160-160	1.3	66	80	74	100	FOT25-8
035	380/50/3	Compact	28-28	160-160	2.4	81	100	92	125	FOT35-8
	400/50/3		27-27	160-160	2.3	78	100	88	100	FOT35-8
	380/50/3	Comprehensive Acoustic	28-28	160-160	1.4	79	100	90	100	FOT35-8
	400/50/3		27-27	160-160	1.3	75	100	85	100	FOT25-8
040	380/50/3	Compact	19-19/19-19	130-130/130-130	2.4	91	100	102	100	FOT35-8
	400/50/3		19-19/19-19	130-130/130-130	2.3	91	100	102	100	FOT35-8
	380/50/3	Comprehensive Acoustic	19-19/19-19	130-130/130-130	1.4	88	100	99	100	FOT35-8
	400/50/3		19-19/19-19	130-130/130-130	1.3	88	100	98	100	FOT35-8
046	380/50/3	Compact	19-19/19-19	130-130/130-130	2.4	100	100	111	125	FOT50-8
	400/50/3		19-19/19-19	130-130/130-130	2.3	100	100	110	125	FOT50-8
	380/50/3	Comprehensive Acoustic	19-19/19-19	130-130/130-130	1.4	99	100	110	125	FOT50-8
	400/50/3		19-19/19-19	130-130/130-130	1.3	99	100	109	125	FOT35-8
052	380/50/3	Compact	22-22/22-22	158-158/158-158	2.4	112	125	123	125	FOT50-8
	400/50/3		22-22/22-22	158-158/158-158	2.3	112	125	122	125	FOT50-8
	380/50/3	Comprehensive Acoustic	22-22/22-22	158-158/158-158	1.4	107	125	118	125	FOT50-8
	400/50/3		22-22/22-22	158-158/158-158	1.3	106	125	117	125	FOT50-8
060	380/50/3	Compact	28-28/28-28	160-160/160-160	2.4	136	160	150	160	FOT70-10
	400/50/3		27-27/27-27	160-160/160-160	2.3	130	125	143	160	FOT70-10
	380/50/3	Comprehensive Acoustic	28-28/28-28	160-160/160-160	1.4	130	125	145	160	FOT70-10
	400/50/3		27-27/27-27	160-160/160-160	1.3	124	125	138	160	FOT70-10
070	380/50/3	Compact	28-35/35-28	160-215/215-160	2.4	152	160	166	200	FOT70-10
	400/50/3		27-33/33-27	160-215/215-160	2.3	145	160	158	160	FOT70-10
	380/50/3	Comprehensive Acoustic	28-35/35-28	160-215/215-160	1.4	146	160	161	160	FOT70-10
	400/50/3		27-33/33-27	160-215/215-160	1.3	139	160	153	160	FOT70-10

Table 2. Electrical Data - CXAM

Size	Volts	Noise	Compressor Motor		Field Wiring					
			RLA	LRA	Fan FLA	Without Pump MCA	MOPD	High Head Pump MCA	MOPD	Ring Size
080	380/50/3	Compact	35-35/35-35	215-215/215-215	2.4	171	200	185	200	FOT95-10
	400/50/3		33-33/33-33	215-215/215-215	2.3	163	160	176	200	FOT95-10
	380/50/3	Comprehensive Acoustic	35-35/35-35	215-215/215-215	1.4	163	160	178	200	FOT95-10
	400/50/3		33-33/33-33	215-215/215-215	1.3	155	160	169	200	FOT70-10
090	380/50/3	Compact	35-46/46-35	215-260/260-215	2.4	195	200	210	250	FOT120-12
	400/50/3		33-44/44-33	215-260/260-215	2.3	186	200	200	200	FOT95-10
	380/50/3	Comprehensive Acoustic	35-46/46-35	215-260/260-215	1.4	188	200	202	200	FOT95-10
	400/50/3		33-44/44-33	215-260/260-215	1.3	179	200	192	200	FOT95-10
100	380/50/3	Compact	46-46/46-46	260-260/260-260	2.4	222	250	236	250	FOT120-12
	400/50/3		44-44/44-44	260-260/260-260	2.3	211	250	225	250	FOT120-12
	380/50/3	Comprehensive Acoustic	46-46/46-46	260-260/260-260	1.4	212.2	250	236.1	250	FOT120-12
	400/50/3		44-44/44-44	260-260/260-260	1.3	202.0	200	215.8	250	FOT120-12
110	380/50/3	Compact	46-51/51-46	260-320/320-260	2.4	232	250	247	250	FOT150-12
	400/50/3		44-51/51-44	260-320/320-260	2.3	227	250	241	250	FOT150-12
	380/50/3	Comprehensive Acoustic	46-51/51-46	260-320/320-260	1.4	225.6	250	240.1	250	FOT120-12
	400/50/3		44-51/51-44	260-320/320-260	1.3	220.1	250	233.9	250	FOT120-12
120	380/50/3	Compact	51-51/51-51	320-320/320-320	2.4	242	250	262	300	FOT150-12
	400/50/3		51-51/51-51	320-320/320-320	2.3	241	250	260	300	FOT150-12
	380/50/3	Comprehensive Acoustic	51-51/51-51	320-320/320-320	1.4	235	250	256	300	FOT150-12
	400/50/3		51-51/51-51	320-320/320-320	1.3	234	250	254	300	FOT150-12
140	380/50/3	Compact	46-35-46/46-35-46	260-215-260/260-215-260	2.4	296	315	317	350	FOT240-14
	400/50/3		44-34-44/44-34-44	260-215-260/260-215-260	2.3	283	315	302	315	FOT185-12
150	380/50/3	Compact	46-46-46/46-46-46	260-260-260/260-260-260	2.4	318	350	339	350	FOT240-14
	400/50/3		44-44-44/44-44-44	260-260-260/260-260-260	2.3	303	315	323	350	FOT240-14
160	380/50/3	Compact	46-46-51/51-46-46	260-260-320/320-260-260	2.4	329	350	357	400	FOT240-14
	400/50/3		44-44-51/51-44-44	260-260-320/320-260-260	2.3	319	350	345	350	FOT240-14

1. Circuit 1/circuit 2
2. RLA - Rated Load Amps
3. LRA - Locked Rotor Amps - Based on full winding starts.
4. MCA - Minimum Circuit Ampacity-125 percent of largest compressor RLA plus 100 percent of all other loads.
5. MOPD or Max Fuse -225 percent of the largest compressor RLA plus 100 percent of all other loads.
6. Voltage Utilization Range:
Rated voltage (use range): 400/50/3 (360-440)
7. One separate 120/50/1, 15 amp customer provided power connection is required to power the heaters. An additional 120/50/1, 15 amp customer provided power connection is required if the optional buffer tank is selected.
8. Local codes may take precedence.
9. Copper wire only, based on nameplate Minimum Circuit Ampacity (MCA).

Electrical Connections

⚠ WARNING
HAZARDOUS VOLTAGE!
DISCONNECT ALL ELECTRIC POWER INCLUDING REMOTE DISCONNECTS AND FOLLOW LOCK OUT AND TAG PROCEDURES BEFORE SERVICING. INSURE THAT ALL MOTOR CAPACITORS HAVE DISCHARGED STORED VOLTAGE. UNITS WITH VARIABLE SPEED DRIVE, REFER TO DRIVE INSTRUCTIONS FOR CAPACITOR DISCHARGE. FAILURE TO DO THE ABOVE COULD RESULT IN DEATH OR SERIOUS INJURY.

⚠ AVERTISSEMENT
TENSION DANGEREUSE!
COUPER TOUTES LES TENSIONS ET OUVRIER LES SECTIONNEURS A DISTANCE, PUIS SUIVRE LES PROCEDURES DE VERROUILLAGE ET DES ETIQUETTES AVANT TOUTE INTERVENTION. VERIFIER QUE TOUTS LES CONDENSATEURS DES MOTEURS SONT DECHARGES. DANS LE CAS D'UNITES COMPORTANT DES ENTRAÎNEMENTS A VITESSE VARIABLE, SE REPORTER AUX INSTRUCTIONS DE L'ENTRAÎNEMENT POUR DECHARGER LES CONDENSATEURS. NE PAS RESPECTER CES MESURES DE PRECAUTION PEUT ENTRAINER DES BLESSURES GRAVES POUVANT ETRE MORTELLES.

⚠ ADVERTENCIA
¡VOLTAJE PELIGROSO!
DESCONECTE TODA LA ENERGIA ELECTRICA, INCLUIDO LAS DESCONEXIONES REMOTAS Y SIGA LOS PROCEDIMIENTOS DE CIERRE Y ETIQUETADO ANTES DE PROCEDER AL SERVICIO. ASEGURESE DE QUE TODOS LOS CAPACITORES DEL MOTOR HAYAN DESCARGADO EL VOLTAJE ALMACENADO. PARA LAS UNIDADES CON TRANSMISION DE VELOCIDAD VARIABLE, CONSULTE LAS INSTRUCCIONES PARA LA DESCARGA DEL CONDENSADOR. EL NO REALIZAR LO ANTERIORMENTE INDICADO, PODRIA OCASIONAR LA MUERTE O SERIAS LESIONES PERSONALES.

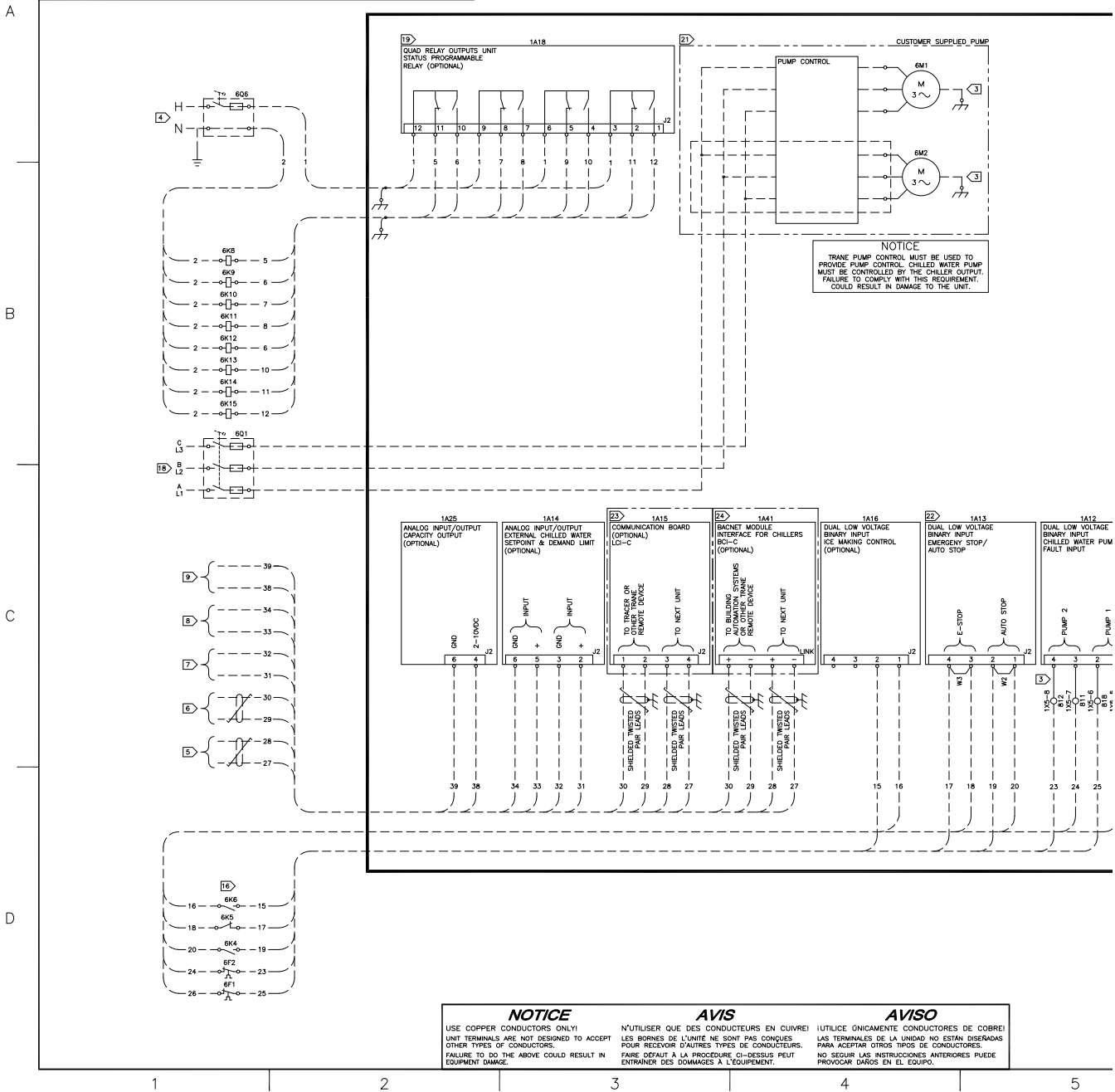

Electrical Connections

A

B

C

D

- 1 SINGLE SOURCE POWER IS PROVIDED AS STANDARD ON THESE PRODUCTS, FIELD CONNECTIONS ARE MADE TO 1X1, OR 1Q2.
- 2 FOR VOLTAGES 200V/60HZ, 220V/50HZ, 380V/60HZ, 460V/60HZ, WIRE 26A SHALL BE CONNECTED TO H2. FOR VOLTAGES 230V/60HZ & 575V/60HZ, WIRE 26A SHALL BE CONNECT TO H3. 400V/50HZ UNIT IS FACTORY WIRED WITH 26A CONNECTED TO H3 – RECONNECT WIRE 26A TO H2 FOR 380V/50HZ, OR H4 FOR 415V/50HZ. H4 IS ONLY AVAILABLE WITH 400V/50HZ PANELS.
- 3 FIELD CONNECTIONS ARE ONLY MADE IN A CUSTOMER PROVIDED PUMP (PTYP=NONE). THESE CONNECTIONS WILL BE MADE BY THE FACTORY WHEN THE PUMP IS PROVIDED BY THE FACTORY (PTYP=DHHP).
- 4 CUSTOMER SUPPLIED POWER 115/60/1 OR 220/50/1 TO POWER RELAYS. MAX. FUSE SIZE IS 20 AMPS. GROUND ALL CUSTOMER SUPPLIED POWER SUPPLIES AS REQUIRED BY APPLICABLE CODES. GREEN GROUND SCREWS ARE PROVIDED IN UNIT CONTROL PANEL.
- 5 WIRED TO NEXT UNIT. 22 AWG SHIELDED COMMUNICATION WIRE EQUIVALENT TO HELIX LF22P0014216 RECOMMENDED. THE SUM TOTAL OF ALL INTERCONNECTED CABLE SEGMENTS NOT TO EXCEED 4500 FEET. CONNECTION TOPOLOGY SHOULD BE DAISY CHAIN. REFER TO BUILDING AUTOMATION SYSTEM (BAS) COMMUNICATION INSTALLATION LITERATURE FOR END OF LINE TERMINATION RESISTOR REQUIREMENTS.
- 6 WIRED TO TRACER OR OTHER TRANE REMOTE DEVICE. 22 AWG SHIELDED COMMUNICATION WIRE EQUIVALENT TO HELIX LF22P0014216 RECOMMENDED. THE SUM TOTAL OF ALL INTERCONNECTED CABLE SEGMENTS NOT TO EXCEED 4500 FEET. CONNECTION TOPOLOGY SHOULD BE DAISY CHAIN. REFER TO BUILDING AUTOMATION SYSTEM (BAS) COMMUNICATION INSTALLATION LITERATURE FOR END OF LINE TERMINATION RESISTOR REQUIREMENTS.
- 7 WIRED TO CUSTOMER CHILLED WATER SET POINT 2–10V OR 4–20mA.
- 8 WIRED TO CUSTOMER EXTERNAL DEMAND LIMIT 2–10V OR 4–20mA.
- 9 WIRED TO CUSTOMER 2–10V OR 4–20mA % CAPACITY ANNUNCIATOR.
11. REFER TO CGAM ELECTRICAL SCHEMATIC FOR SPECIFIC ELECTRICAL CONNECTION INFORMATION AND NOTES PERTAINING TO WIRING INSTALLATION.
- 12 ALL UNIT POWER WIRING MUST BE 600 VOLT COPPER CONDUCTORS ONLY AND HAVE A MINIMUM TEMPERATURE INSULATION RATING OF 90 DEGREE C. REFER TO UNIT NAMEPLATE FOR MINIMUM CIRCUIT AMPACITY AND MAXIMUM OVERCURRENT PROTECTION DEVICE. PROVIDE AN EQUIPMENT GROUND IN ACCORDANCE WITH APPLICABLE ELECTRIC CODES. REFER TO WIRE RANGE TABLE FOR LUG SIZES.
13. ALL FIELD WIRING MUST BE IN ACCORDANCE WITH NATIONAL ELECTRIC CODE AND LOCAL REQUIREMENTS.
14. ALL CUSTOMER CONTROL CIRCUIT WIRING MUST BE COPPER CONDUCTORS ONLY AND HAVE A MINIMUM INSULATION RATING OF 300 VOLTS. EXCEPT AS NOTED, ALL CUSTOMER WIRING CONNECTIONS ARE MADE TO CIRCUIT BOARD MOUNTED BOX LUGS WITH A WIRE RANGE OF 14 TO 18 AWG OR DIN RAIL MOUNTED SPRING FORCE TERMINALS.
- 15 UNIT PROVIDED DRY CONTACTS FOR THE CONDENSER/CHILLED WATER PUMP CONTROL. RELAYS ARE RATED FOR 7.2 AMPS RESISTIVE, 2.88 AMPS PILOT DUTY, OR ½ HP, 7.2 FLA AT 120 VOLTS 60 HZ, CONTACTS ARE RATED FOR 5 AMPS GENERAL PURPOSE DUTY 240 VOLTS.
- 16 CUSTOMER SUPPLIED CONTACTS FOR ALL LOW VOLTAGE CONNECTIONS MUST BE COMPATIBLE WITH DRY CIRCUIT 24 VOLTS DC FOR A 12 mA RESISTIVE LOAD. SILVER OR GOLD PLATED CONTACTS RECOMMENDED.
- 17 FIELD CONNECTIONS ARE ONLY MADE IN A CUSTOMER PROVIDED PUMP. THESE CONNECTIONS WILL BE MADE BY THE FACTORY WHEN THE PUMP IS PROVIDED BY THE FACTORY. CUSTOMER SUPPLIED POWER 115V, 60Hz, 1PH.
- 18 CUSTOMER SUPPLIED 3 PHASE POWER.
- 19 OPTIONAL FIELD ASSIGNED PROGRAMMABLE RELAYS (STAT=PRLY). CLASS 1 FIELD WIRED MODULE, RELAY AT 120V: 7.2A RESISTIVE 2.88A PILOT DUTY, 1/2HP 7.2FLA; AT 240VAC: 5 AMPS GENERAL PURPOSE.
- 20 WIRED TO CUSTOMER 0–10 VDC PUMP SPEED SIGNAL.
- 21 WHEN FACTORY PROVIDED PUMP IS NOT SELECTED, CUSTOMER MUST SUPPLY SUITABLE PUMP SYSTEM. REFER TO PUMP MANUFACTURER FOR WIRING REQUIREMENTS.
- 22 THE CONTACTS FOR AUTO STOP AND EMERGENCY STOP SWITCHES ARE JUMPERED AT THE FACTORY BY JUMPERS W2 & W3 TO ENABLE UNIT OPERATION. IF REMOTE CONTROL IS DESIRED, REMOVED THE JUMPERS AND CONNECT TO THE DESIRED CONTROL CIRCUIT.
- 23 1A15, LCI MODULE USED WHEN (COMM = LCI).
- 24 1A41, BACNET INTERFACE MODULE USED WHEN (COMM = BCNT).

1

2

3

4

5

TRANE		2309-2076	SHEET 2 OF 2	REV C
THIS DRAWING IS PROPRIETARY AND SHALL NOT BE COPIED OR ITS CONTENTS DISCLOSED TO OUTSIDE PARTIES WITHOUT THE WRITTEN CONSENT OF TRANE.				
DRAWN BY:		FIELD WIRING DIAGRAM CGAM (NAR) SLANT, V & W UNITS		
REPLACES:				
REVISION DATE:				
SIMILIAR TO:				
		© TRANE DATE: 12/5/08		

REPLACEMENT FUSE TABLE					
FUSE	VOLTAGE	Hz	CLASS	AMPS	NOTES
1F1	ALL	ALL	CC	10	FUSE, COMPRESSOR CRANKCASE HEATER, CIRCUIT 1
1F2	ALL	ALL	CC	10	
1F3	ALL	ALL	CC	10	FUSE, COMPRESSOR CRANKCASE HEATER, CIRCUIT 2
1F4	ALL	ALL	CC	10	
1F5, 1F6	200	60	CC	10	FUSE, CONTROL POWER TRANSFORMER, PRIMARY
	230	60	CC	8	
	380	60	CC	5	
	400	50	CC	5	
	460	60	CC	5	
1F7	575	60	CC	4	THIRD PHASE, PHASE PROTECTION MONITOR
	200	60	CC	10	
	230	60	CC	8	
	380	60	CC	5	
	400	50	CC	5	
1F8, 1F9, 1F10	460	60	CC	5	DUAL POINT, POWER SECOND PHASE, PHASE PROTECTION MONITOR
	575	60	CC	4	
	200	60	CC	10	
	230	60	CC	8	
	380	60	CC	5	
1F11	ALL	ALL	CC	10	FUSE, CONTROL POWER TRANSFORMER, SECONDARY, 115V
1F12 - 1F13	ALL	ALL	CC	6	FUSE, CONTROL POWER TRANSFORMER, SECONDARY, 24V
1F14 - 1F16 1F17 - 1F19	200-460	ALL	CC	30	FUSE, INVERTER, FAN (FAST ACTING EXCEPT 575V)
	575	60	CC	6	
1F38 - 1F40 1F44 - 1F46	ALL	ALL	CC	30	FAST ACTING FUSE, ATM-R-30
1F38 - 1F40 1F41 - 1F43	ALL	ALL	CC	30	FAST ACTING FUSE, USED ONLY ON W UNITS
FACTORY PROVIDED PUMP INVERTER FUSE					
1F32, 1F33, 1F34	200,230	60	J	30	3.7Kw VSD
	460,575	60	J	25	5.5 Kw VSD
	200,230	60	J	60	7.5Kw VSD
			CC	30	
	200,230	60	J	60	11Kw VSD
	460,575			40	

Dimensions

Figure 1. CGAM 20 and 23 ton (compact and comprehensive acoustic package versions), 26 ton (compact version), CXAM 20 (compact and comprehensive acoustic package version), 23 (compact version)

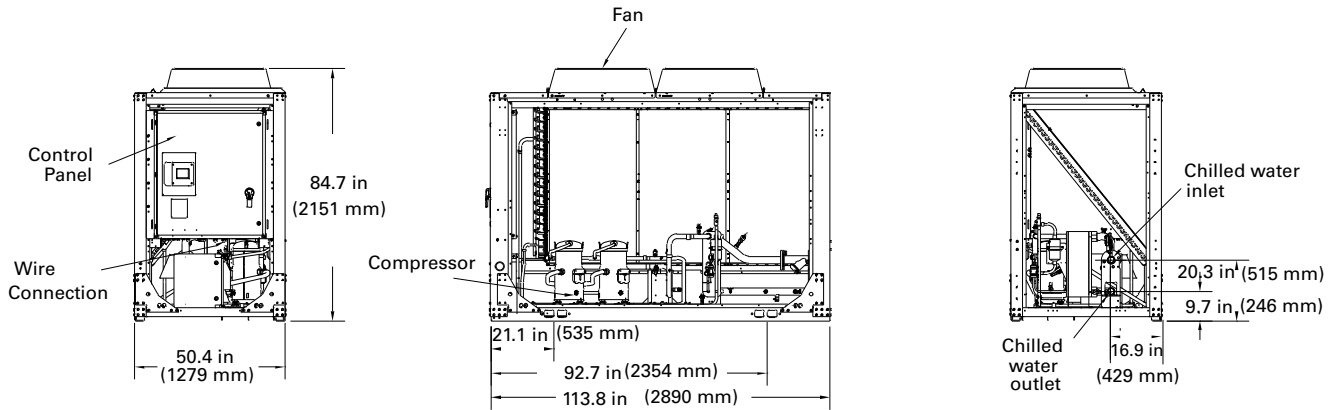

Water connections are 1.8 in (44 mm) from the end.

Figure 2. CGAM 20 and 23 ton (compact and comprehensive acoustic package versions), 26 ton (compact version), CXAM 20 (compact and comprehensive acoustic package version), 23 (compact version) - service clearances and mounting locations

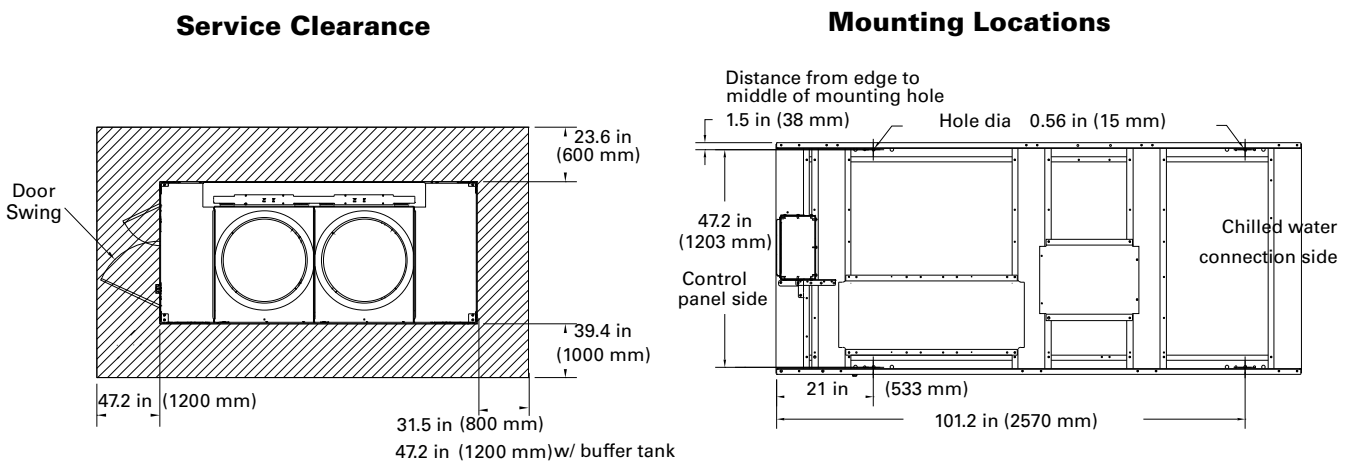

More clearance may be needed for airflow depending on the installation.

Total of four mounting locations.

Figure 3. CGAM 26 ton (comprehensive acoustic package version), 30 and 35 ton (compact and comprehensive acoustic package versions), CXAM 23 ton (comprehensive acoustic package version), 26-35 ton (compact and comprehensive acoustic package versions)

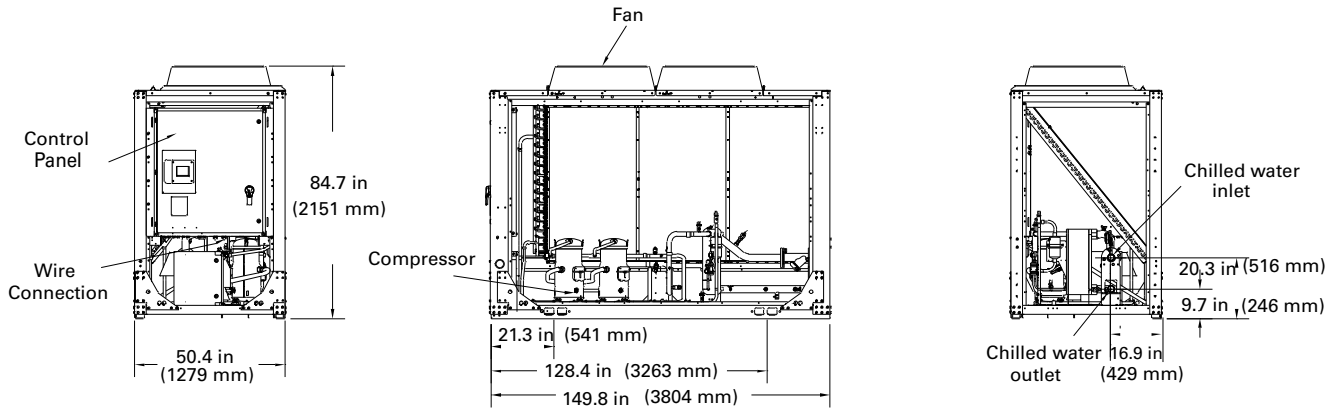

The number of fans shown does not represent the number of fans installed.

Water connections are 1.6 in (40 mm) from unit end.

Figure 4. CGAM 26 ton (comprehensive acoustic package versions), 30 and 35 ton (compact and comprehensive acoustic package versions), CXAM 23 ton (comprehensive acoustic package version), 26-35 ton (compact and comprehensive acoustic package versions) - service clearances and mounting locations

Service Clearance

The number of fans shown does not represent the number of fans installed.

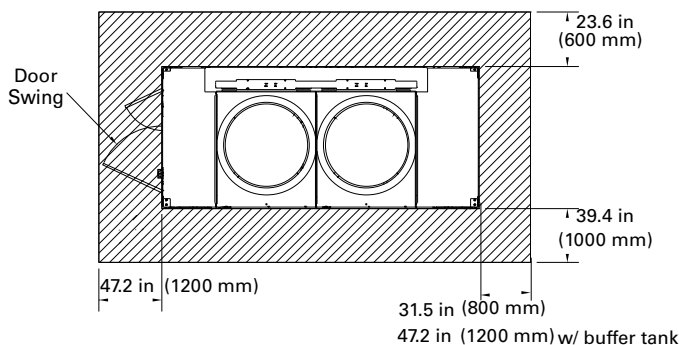

More clearance may be needed for airflow depending on the installation.

Mounting Locations

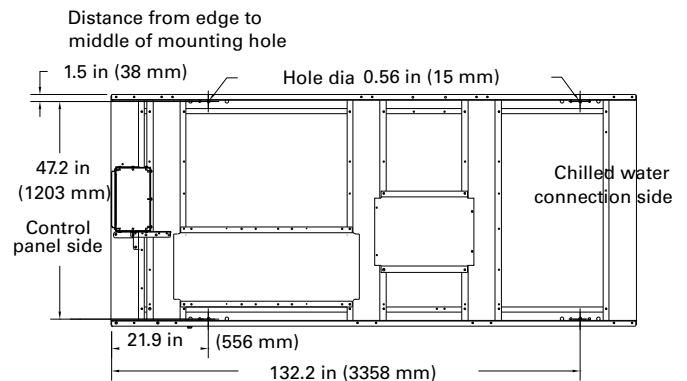

Total of four mounting locations.

Dimensions

Figure 5. CGAM 40 and 46 ton (compact and comprehensive acoustic package versions), 52 ton (compact version), CXAM 40 (compact and comprehensive acoustic package versions), 46 ton (compact version)

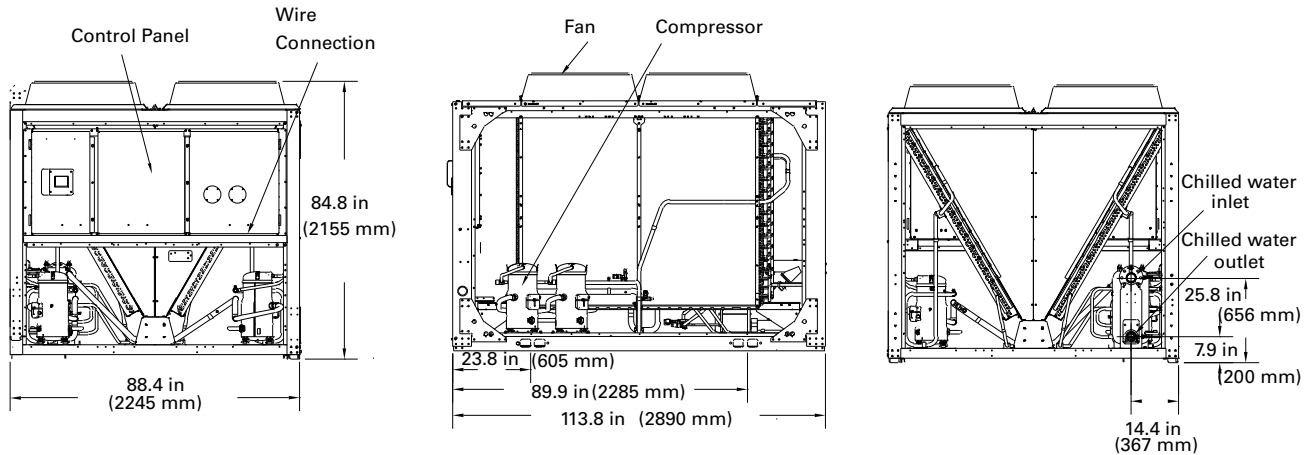

Water connections are 1.9 in (50 mm) outside unit end.

Figure 6. CGAM 40 and 46 ton (compact and comprehensive acoustic package versions), 52 ton (compact version), CXAM 40 (compact and comprehensive acoustic package versions), 46 ton (compact version)- service clearances and mounting locations

Service Clearance

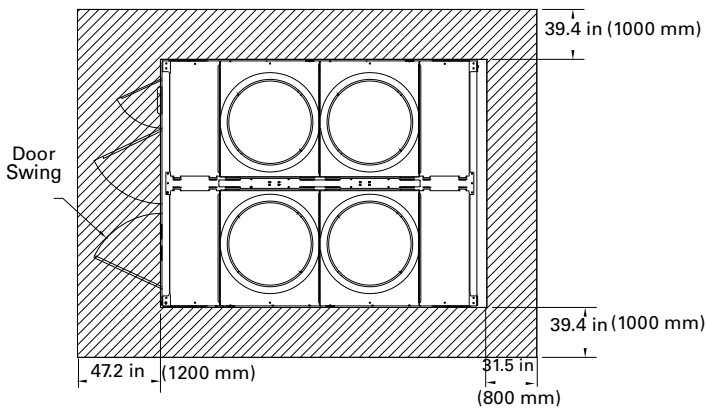

More clearance may be needed for airflow depending on the installation.

Mounting Locations

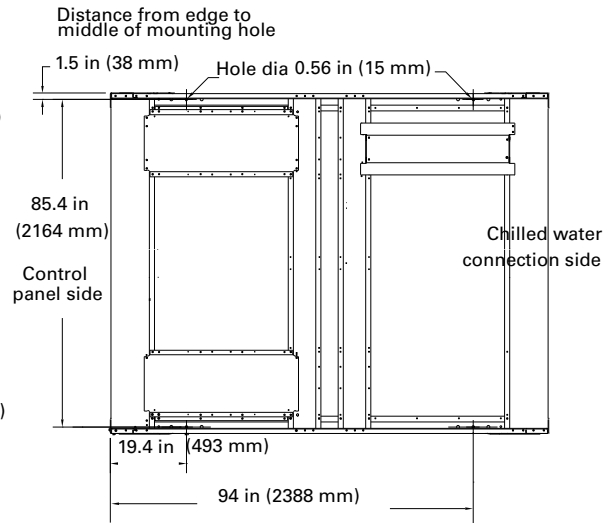

Total of four mounting locations.

Figure 7. CGAM 52 ton (comprehensive acoustic package version), 60 and 70 ton (compact and comprehensive acoustic package versions), CXAM 46 (comprehensive acoustic package version), 52-70 ton (compact and comprehensive acoustic package versions)

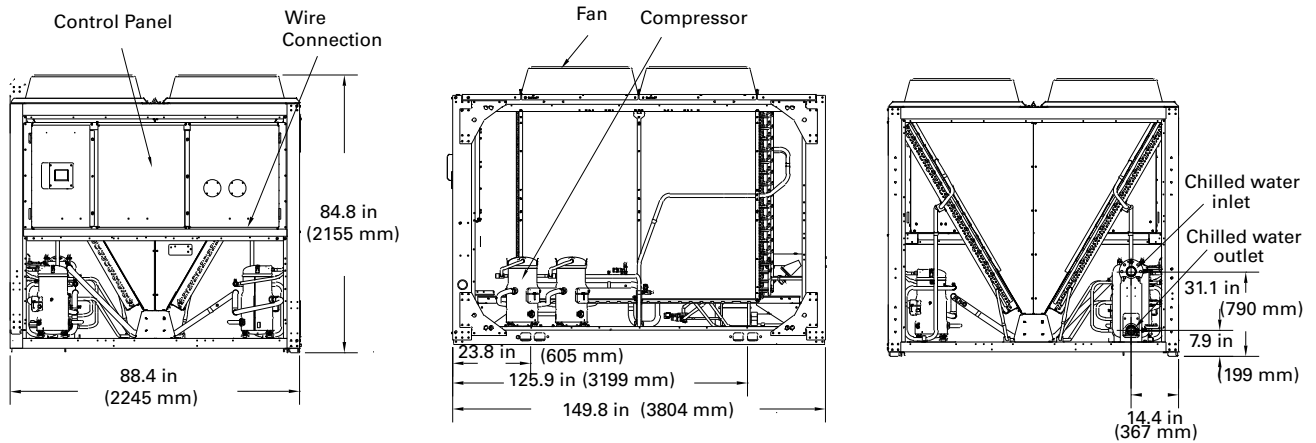

The number of fans shown does not represent the number of fans installed.

Water connections are even with unit end.

Figure 8. CGAM 52 ton (comprehensive acoustic package version), 60 and 70 ton (compact and comprehensive acoustic package versions), CXAM 46 (comprehensive acoustic package version), 52-70 ton (compact and comprehensive acoustic package versions)- service clearances and mounting locations

Service Clearance

The number of fans shown does not represent the number of fans installed.

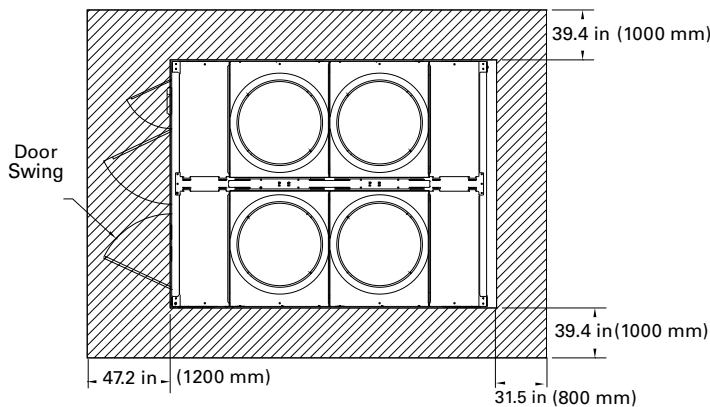

More clearance may be needed for airflow depending on the installation.

Mounting Locations

Distance from edge to middle of mounting hole

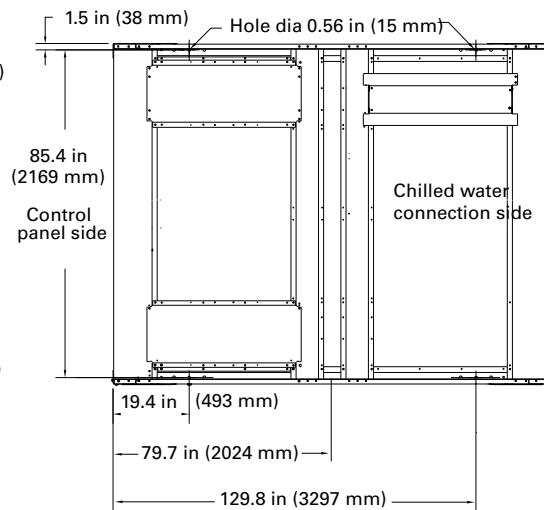

Total of six mounting locations.

Dimensions

Figure 9. CGAM 80 and 90 (compact version)

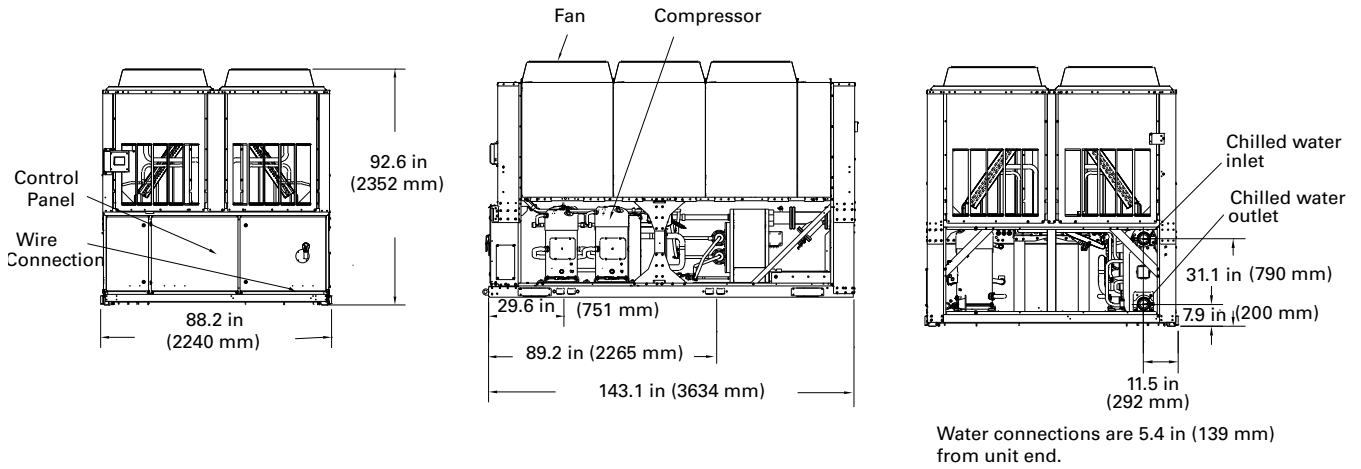
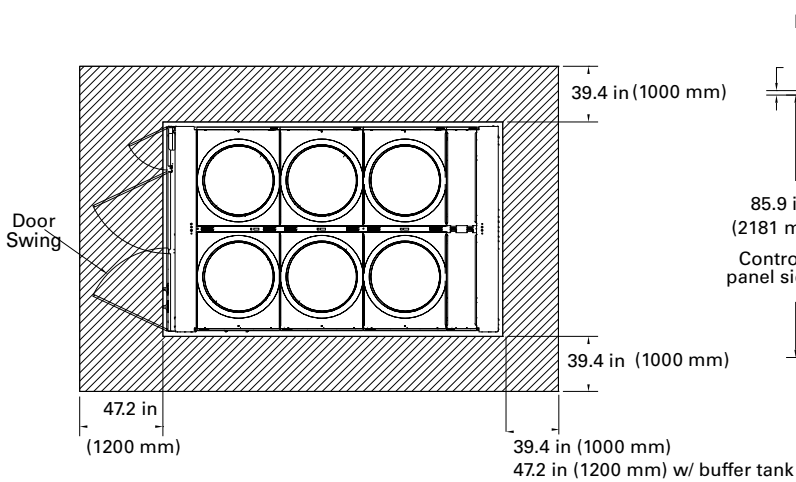

Figure 10. CGAM 80 and 90 (compact version) - service clearances and mounting locations

Service Clearance



More clearance may be need for airflow depending on the installation.

Mounting Locations

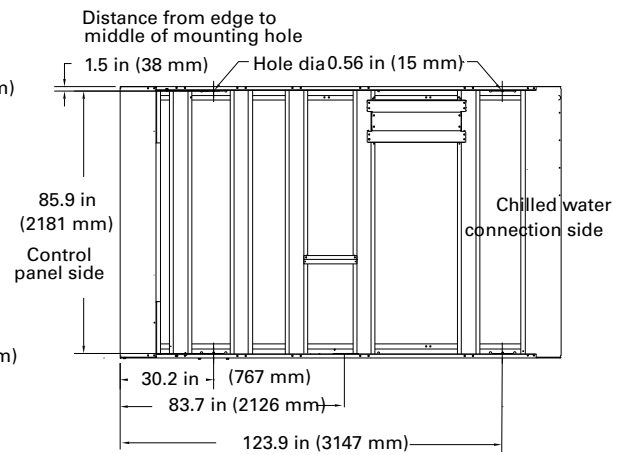

Total of six mounting location.

Figure 11. CGAM 80 and 90 (comprehensive acoustic package version), 100 (compact and comprehensive acoustic package versions), 110 (compact version), CXAM 80 (compact and comprehensive acoustic package versions), 90 (compact version)

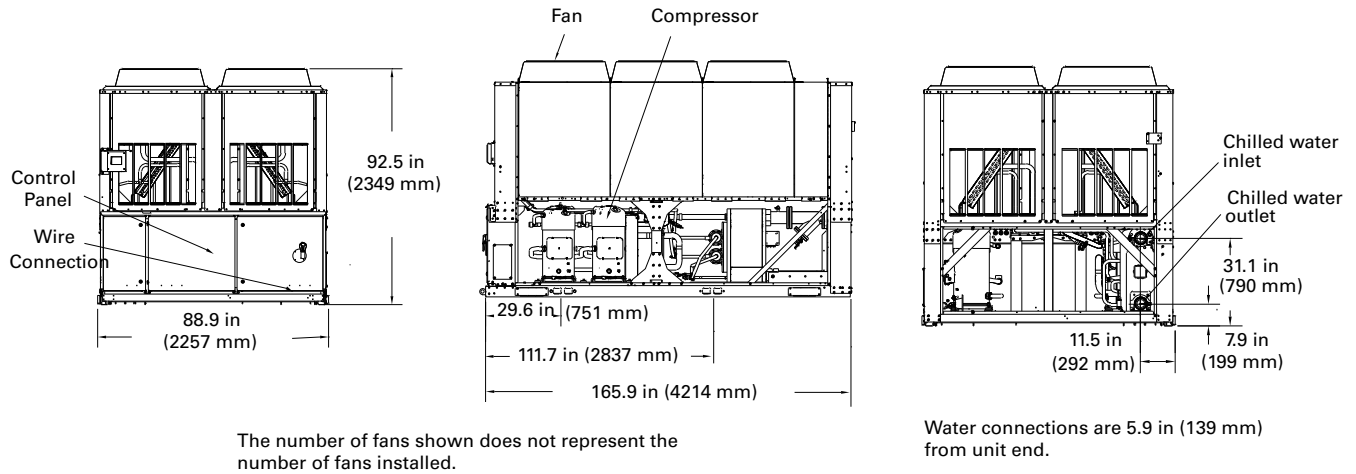
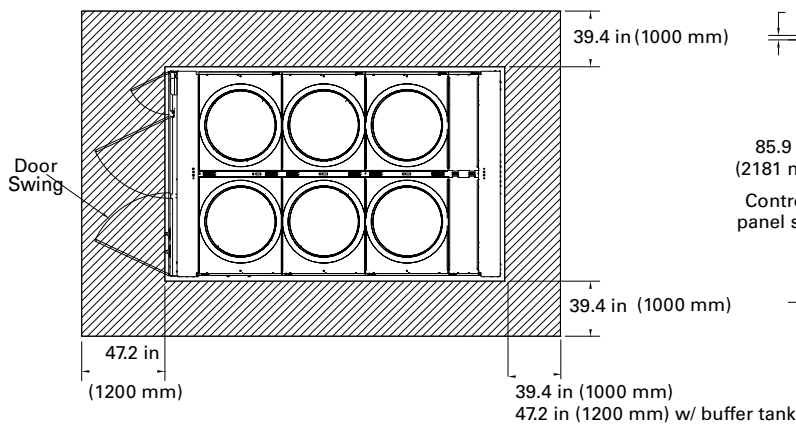

Figure 12. CGAM 80 and 90 (comprehensive acoustic package version), 100 (compact and comprehensive acoustic package versions), 110 (compact version), CXAM 80 (compact and comprehensive acoustic package versions), 90 (compact version) - service clearances and mounting locations

Service Clearance

The number of fans shown does not represent the number of fans installed.



More clearance may be needed for airflow depending on the installation.

Mounting Locations

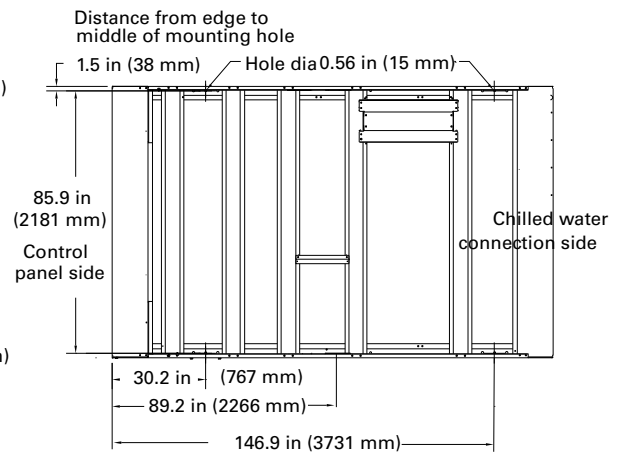

Total of six mounting locations.

Dimensions

Figure 13. CGAM 110 and 120 (comprehensive acoustic package versions), 140 (compact version), CXAM 90 (comprehensive acoustic package versions), 100 (compact and comprehensive acoustic package versions), 110 and 120 (compact version)

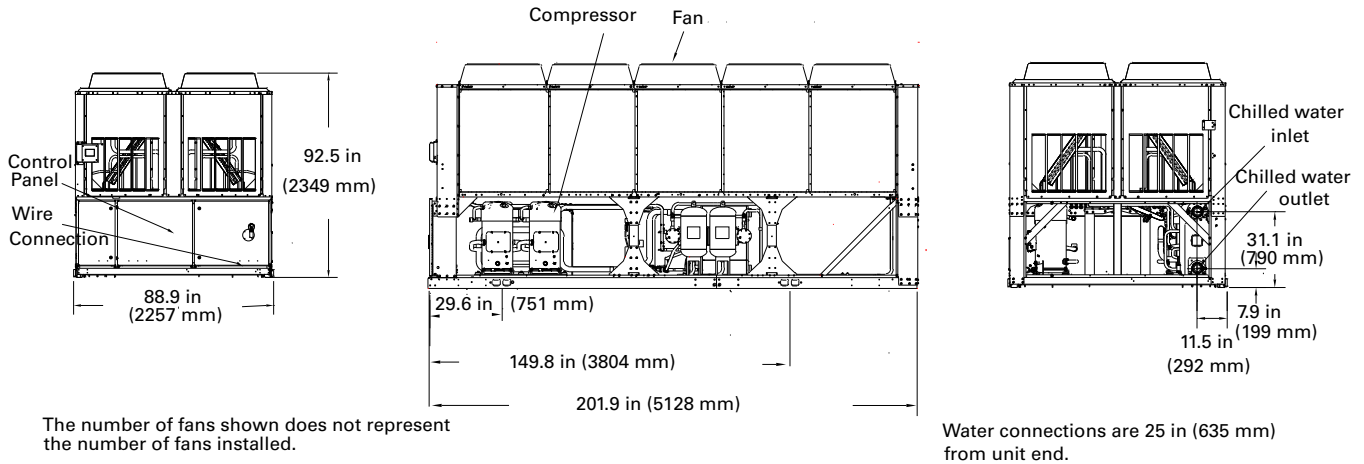
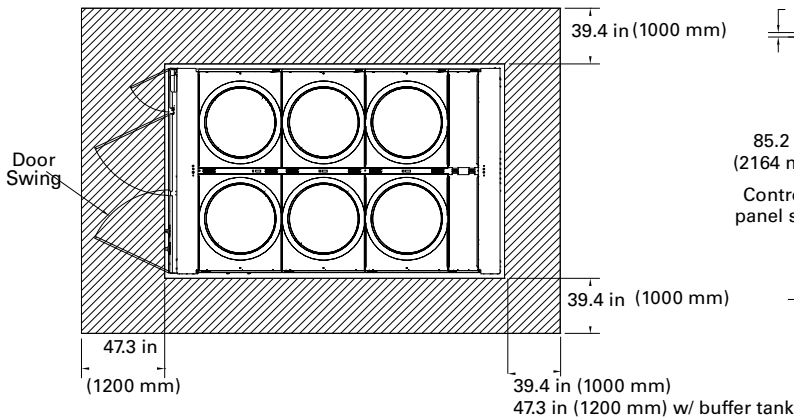

Figure 14. CGAM 110 and 120 (comprehensive acoustic package versions), 140 (compact version), CXAM 90 (comprehensive acoustic package versions), 100 (compact and comprehensive acoustic package versions), 110 and 120 (compact version) - service clearances and mounting locations

Service Clearance

The number of fans shown does not represent the number of fans installed.



More clearance may be needed for airflow depending on the installation.

Mounting Locations

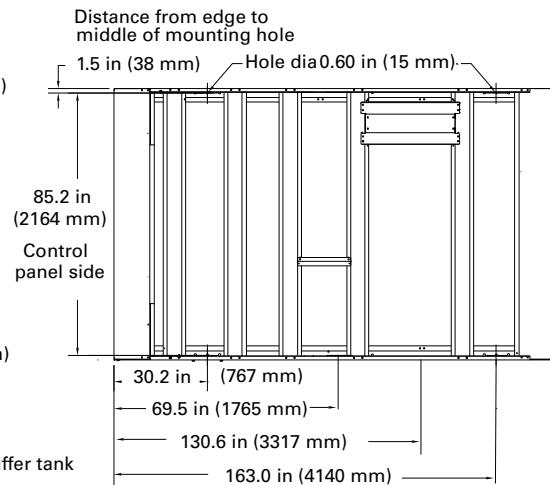

Figure 15. CGAM 140 (comprehensive acoustic package version), 150 and 160 (compact and comprehensive acoustic package versions), CXAM 110 and 120 (comprehensive acoustic package version), 140, 150 and 160 (compact)

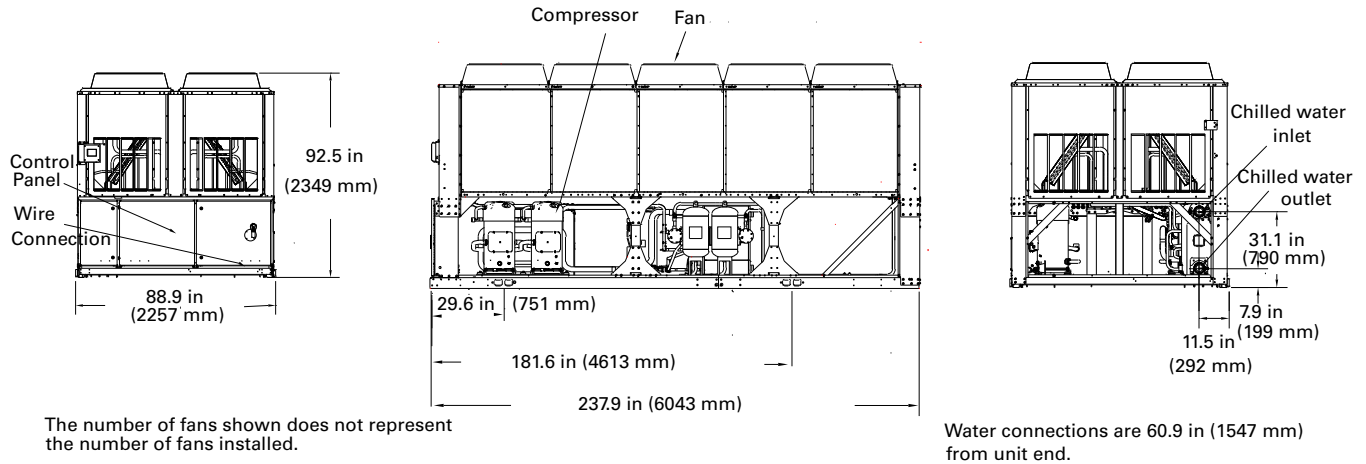
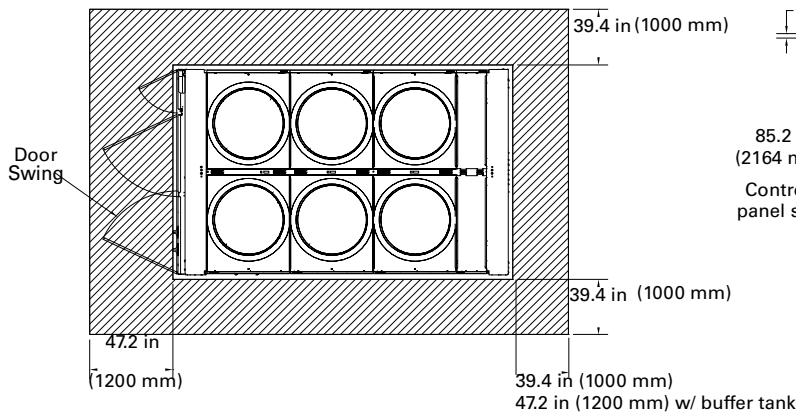

Figure 16. CGAM 140 (comprehensive acoustic package version), 150 and 160 (compact and comprehensive acoustic package versions), CXAM 110 and 120 (comprehensive acoustic package version), 140, 150 and 160 (compact)- service clearances and mounting locations

Service Clearance

The number of fans shown does not represent the number of fans installed.



Mounting Locations

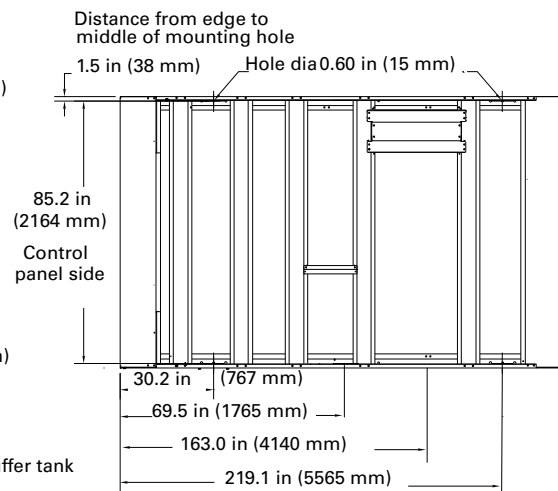

Weights

Table 1. Weights - CGAM - Compact Units

Tons	Base Unit Weight - kg		Pump Unit Weight - kg		Pump and Buffer Tank Weight- kg	
	Shipping	Operating	Shipping	Operating	Shipping	Operating
20	862	890	1024	1070	1396	1976
23	866	894	1029	1076	1401	1982
26	887	918	1050	1099	1422	2005
30	1107	1138	1311	1360	1683	2266
35	1122	1157	1331	1383	1702	2290
40	1529	1561	1708	1758	2145	2700
46	1557	1594	1736	1791	2173	2734
52	1570	1607	1749	1804	2185	2746
60	1994	2034	2216	2286	2652	3227
70	2026	2076	2248	2327	2685	3269
80	2332	2380	2739	2816	2979	3637
90	2446	2502	2852	2936	3093	3757
100	2738	2798	3144	3233	3444	4278
110	2773	2838	3179	3272	3480	4317
120	2794	2859	3283	3391	3584	4436
140	3326	3393	3836	3948	4136	4992
150	3801	3869	4357	4469	4657	5512
160	3822	3890	4406	4517	4705	5561

1. Weights based on aluminum fins.
2. Weights do not include: partial heat recovery, louvered panels, etc.
3. All weights $\pm 5\%$.

Table 2. Weights - CGAM - Comprehensive Acoustic Package Units

Tons	Base Unit Weight - kg		Pump Unit Weight - kg		Pump and Buffer Tank Weight- kg	
	Shipping	Operating	Shipping	Operating	Shipping	Operating
20	896	924	1058	1105	1430	2011
23	916	947	1079	1128	1451	2034
26	1047	1076	1251	1298	1623	2204
30	1145	1174	1349	1397	1721	2302
35	1162	1195	1371	1422	1742	2328
40	1615	1653	1794	1850	2231	2791
46	1626	1663	1804	1860	2241	2802
52	1876	1913	2056	2112	2493	3054
60	2084	2125	2305	2375	2742	3317
70	2117	2166	2338	2417	2775	3360
80	2548	2598	2955	3034	3255	4078
90	2746	2802	3153	3237	3453	4281
100	2852	2912	3258	3348	3558	4392
110	3128	3188	3556	3645	3856	4689
120	3253	3317	3763	3872	4064	4916
140	3863	3931	4420	4531	4720	5576
150	3954	4022	4511	4623	4812	5667
160	3976	4044	4559	4671	4859	5715

1. Weights based on aluminum fins.
2. Weights do not include: partial heat recovery, louvered panels, etc.
3. All weights $\pm 5\%$.

Weights

Table 3. Weights - CXAM - Compact

Tons	Base Unit Weight - kg		Pump Unit Weight - kg		Pump and Buffer Tank Weight- kg	
	Shipping	Operating	Shipping	Operating	Shipping	Operating
20	940	969	1102	1150	1474	2056
23	945	975	1108	1155	1480	2062
26	1152	1183	1357	1406	1728	2312
30	1240	1269	1445	1492	1817	2398
35	1258	1291	1466	1517	1838	2424
40	1714	1752	1893	1949	2330	2891
46	1725	1762	1903	1958	2340	2901
52	1980	2018	2161	2216	2597	3158
60	2169	2207	2391	2458	2828	3400
70	2212	2262	2435	2513	2871	3455
80	2658	2712	3065	3148	3365	4192
90	2775	2837	3181	3272	3481	4316
100	3227	3294	3655	3751	3955	4796
110	3230	3292	3659	3750	3959	4794
120	3260	3324	3771	3879	4071	4924
140	3834	3901	4390	4501	4690	5546
150	3924	3992	4481	4593	4782	5637
160	3946	4014	4529	4641	4829	5685

1. Weights based on aluminum fins.
2. Weights do not include: partial heat recovery, louvered panels, etc.
3. All weights $\pm 5\%$.

Table 4. Weights - CXAM - Comprehensive Acoustic Package Units

Tons	Base Unit Weight - kg		Pump Unit Weight - kg		Pump and Buffer Tank Weight - kg	
	Shipping	Operating	Shipping	Operating	Shipping	Operating
20	974	1004	1136	1184	1508	2090
23	1175	1204	1379	1426	1751	2333
26	1200	1229	1404	1451	1777	2358
30	1292	1323	1496	1545	1868	2451
35	1302	1336	1511	1562	1883	2468
40	1782	1820	1961	2017	2398	2959
46	2038	2075	2218	2274	2655	3216
52	2089	2127	2270	2326	2707	3268
60	2259	2297	2482	2548	2918	3490
70	2303	2353	2524	2603	2962	3546
80	2793	2853	3199	3289	3499	4333
90	3137	3197	3565	3655	3866	4699
100	3341	3409	3769	3865	4070	4910
110	3739	3803	4213	4307	4513	5351
120	3771	3839	4327	4439	4628	5483

1. Weights based on aluminum fins.
2. Weights do not include: partial heat recovery, louvered panels, etc.
3. All weights $\pm 5\%$.



Trane optimizes the performance of homes and buildings around the world. A business of Ingersoll Rand, the leader in creating and sustaining safe, comfortable and energy efficient environments, Trane offers a broad portfolio of advanced controls and HVAC systems, comprehensive building services, and parts. For more information, visit www.Trane.com.

Trane has a policy of continuous product and product data improvement and reserves the right to change design and specifications without notice.

© 2010 Trane All rights reserved
CG-PRC018-EN 20 Dec 2010
Supersedes: CG-PRC018-EN (01 Nov 2010)

