



Product Catalogue

CGAD Liquid Chillers Air-Cooled Scroll Compressor 20 to 150 Tons



Models: 50 / 60 Hz

CGAD020	CGAD040	CGAD070	CGAD100
CGAD025	CGAD050	CGAD080	CGAD120
CGAD030	CGAD060	CGAD090	CGAD150



July 2012

CG-PRC002E-EN

Introduction

IMPORTANT:
Dimensional measuring units on this catalog are on millimetres (mm). (Except for those locally referenced).

**CGAD
Air-Cooled Liquid Chillers
Designed for great performance.
Built to last.**

For more than 40 years Trane has been using the best resources available on development engineering, production and marketing to produce quality equipments. All this tradition and know-how were gathered to develop the new generation of CGAD liquid chillers 20 to 150 Tons, equipped with scroll compressors.



It's Hard To Stop A Trane.®



Contents

Introduction	2
Model Number	4
General Data	5
Selection Procedures	6
Application Considerations	7
Performance Adjustment Factors	9
Performance Data	12
Acoustic Pressure Levels	16
Controls	17
Electrical Data	21
Dimensional Data	22
Mechanical Especifications	34
General Dimensions	36
Conversion Table	37



Model Number

C	G	A	D	1	5	0	J	B	A	0	N	2	N	N	A	N	0	N	N	N	N	N	N	N	N	0	N	P	0	0	0	N
1	2	3	4	5	6	7	8	9	10	11	12	13	14	15	16	17	18	19	20	21	22	23	24	25	26	27	28	29	30	31	32	33

Digits 1, 2 - Unit Model
CG = "Cold Generator" Scroll Chiller

Digit 3 - Unit Type
A = Air Cooled

Digit 4 - Model Series
D = Sequence D

Digits 5, 6 e 7 - Nominal Capacity
020 = 20 Ton.
025 = 25 Ton.
030 = 30 Ton.
040 = 40 Ton.
050 = 50 Ton.
060 = 60 Ton.
070 = 70 Ton.
080 = 80 Ton.
090 = 90 Ton.
100 = 100 Ton.
120 = 120 Ton.
150 = 150 Ton.

Digit 8 - Unit Voltage
C = 220/60/3
J = 380/60/3
D = 380-400/50/3
4 = 440-460/60/3

Digit 9 - Manufacturing Location
B = Curitiba Plant - Brazil

Digits 10,11 - Sequence of Modifi. minor of Project
A0 - Sequence A0 (Defined by factory)

Digit 12 - Certifying Agency
N = No certification

Digit 13 - Refrigerant Type
2 = R22
4 = R407c

Digit 14 - Expansion Valve type
N = Thermostatic

Digit 15 - Evaporator Application
N = Standard Cooling (40-60°F)

Digit 16 - Coil Type
A = Aluminium fins
S = Yellow Fin

Digit 17 - Piping Configuration
N = Standard
A = Service valves on suction and discharge lines

Digit 18 - Digit Reserved
0 = Reserved

Digit 19 - Feed Type
N = Terminal Block
D = Disconnecter Key
C = Circuit Breaker

Digit 20 - Remote Operation Interface
N = No Remote Interface
C = Tracer Comm3 Interface
L = Comm5 - LonTalk Compatible (LCI-C) Interface

Digit 21 - Input controls
N = No controls
R = External Leaving Water Setpoint

Digit 22 - Output controls
N = No controls
A = Alarm Relay Output

Digit 23 - Electrical Accessories
N = No accessories

Digit 24 - Control Panel Accessories
N = No accessories

Digit 25 - Protection panels
N = No Protection panels

Digit 26 - Installation accessories
N = Without Installation accessories
R = Neoprene Vibration isolators
F = Adapter Kit for Flange
G = Isolator and Flange adapter kit

Digit 27 - Digit Reserved
0 = Reserved

Digit 28 - Digit Reserved
0 = Reserved

Digit 29 - Language - Literature/Labels
P = Portuguese/Spanish

Digit 30 - Digit Reserved
0 = Reserved

Digit 31 - Digit Reserved
0 = Reserved

Digit 32 - Digit Reserved
0 = Reserved

Digit 33 - Product Type
N = Standard
Z = Special

The product's code describes the configuration, capacity, and optional characteristics. It is very important to indicate the correct order of the equipment's code in order to avoid future problems when delivering them. Above you will find the description of each digit that makes up the product code.



General Data

Tab. 01 - General Data - CGAD 20-90 TR - 50 or 60 Hz

Model ⁽¹⁾		CGAD020	CGAD025	CGAD030	CGAD040	CGAD050	CGAD060	CGAD070	CGAD080	CGAD090	CGAD100	CGAD120	CGAD150
60 Hz													
Capacity	Tons	17,9	21,4	26,5	36,1	42,8	52,6	65,7	76,2	82,6	95,3	116,8	144,0
System KW ⁽³⁾		20,0	27,2	30,7	41,3	53,9	61,6	71,8	82,2	93,9	106,5	135,3	156,5
MCA ⁽²⁾	A	54,0	68,0	78,0	97,0	123,0	142,0	163,0	192,0	210,0	255,0	295,0	376,0
Efficiency ⁽³⁾	E.E.R.	10,8	9,4	10,4	10,5	9,5	10,2	11,0	11,1	10,5	10,7	10,4	11,0
	KW/TR	1,115	1,273	1,157	1,143	1,258	1,171	1,093	1,079	1,137	1,118	1,158	1,087
50 Hz													
Capacity	Tons	15,5	18,6	23,0	31,2	37,2	45,5	56,5	65,4	71,2	85,2	104,7	128,6
System KW ⁽³⁾		16,8	23,0	25,8	34,6	45,6	51,8	59,9	68,9	78,4	95,4	121,0	140,5
MCA ⁽⁴⁾	A	45,0	57,0	65,0	80,0	110,0	116,0	130,0	150,0	170,0	190,0	225,0	284,0
Efficiency ⁽³⁾	E.E.R.	11,1	9,7	10,7	10,8	9,8	10,6	11,3	11,4	10,9	10,7	10,4	11,0
	KW/TR	1,086	1,238	1,123	1,109	1,227	1,137	1,060	1,053	1,102	1,119	1,155	1,093
Compressor													
Model ⁽⁷⁾		SM125	SM185 SM125	SM185	SM125	SM185 SM125	SM185	SM185 SM125	SM185 SM125	SM185	SY300	SY240	SY300
Type		Scroll	Scroll	Scroll	Scroll	Scroll	Scroll	Scroll	Scroll	Scroll	Scroll	Scroll	Scroll
Quantity		2	1 / 1	2	4	2 / 2	4	2 / 4	4 / 2	6	4	6	6
Nominal Capacity	Tons	10	15/10	15/15	10	15/10	15	15 / 10	15 / 10	15	25	20	25
Evaporator													
Water Storage	Liters	44	41	62	52	79	143	151	143	122	122	173	277
Min. water flow rate	m ³ /h	5,5	6,8	8,2	10,9	13,6	16,4	21,8	27,3	27,3	32,7	40,9	49,1
Max. water flow rate	m ³ /h	16,4	20,4	24,5	32,7	40,9	49,1	65,4	81,8	81,8	98,1	122,7	147,2
Inlet connection ⁽⁸⁾		2"	2"	2 1/2"	2 1/2"	3"	4"	4"	4"	4"	4"	6"	6"
Outlet connection ⁽⁸⁾		2"	2"	2 1/2"	2 1/2"	3"	4"	4"	4"	4"	4"	6"	6"
Condenser													
Type		Aluminum fins, 3/8"- OD copper tubes											
No. of coils		2	2	2	4	4	4	4	4	4	4	4	4
Total face area	m ²	4,7	4,7	4,7	8,5	11,0	11,0	14,0	14,7	14,7	13,1	16,9	19,5
Fins per inches		16	16	14	16	16	16	14	14	14	16	16	16
No. of rows		2	2	3	2	2	2	3	3	3	3	3	3
Fans													
Quantity		2	3	3	4	6	6	6	8	8	6	8	10
Diameter	mm	762	762	762	762	762	762	762	762	762	762	762	762
Air flow rate	m ³ /h	32.620	45.870	44.170	64.560	95.140	95.140	97.690	122.330	122.330	98.118	130.824	163.530
RPM	RPM	1140	1140	1140	1140	1140	1140	1140	1140	1140	1140	1140	1140
Motor power	KW	1,12	1,12	1,12	1,12	1,12	1,12	1,12	1,12	1,12	1,12	1,12	1,12
Transmission type		Direct	Direct	Direct	Direct	Direct	Direct	Direct	Direct	Direct	Direct	Direct	Direct
General Data													
Height	mm	1840,5	1840,5	1840,5	2190,5	2190,5	2190,5	2190,5	2190,5	2190,5	2376,0	2376,0	2376,0
Length ⁽⁵⁾	mm	2195,0	2195,0	2195,0	2389,0	2989,0	2989,0	3695,0	3903,0	3903,0	3425,0	4949,0	4949,0
Width	mm	1350,0	1700,0	1700,0	1880,0	1880,0	1880,0	1880,0	1880,0	1880,0	2242,0	2242,0	2242,0
Footprint area ⁽⁶⁾	m ²	2,700	3,400	3,400	3,940	5,250	5,250	6,580	6,970	6,970	7,237	10,654	10,654
Refrigerant type	Standard	R-22	R-22	R-22	R-22	R-22	R-22	R-22	R-22	R-22	R-22	R-22	R-22
	Optional	R-407C	R-407C	R-407C	R-407C	R-407C	R-407C	R-407C	R-407C	R-407C	R-407C	R-407C	R-407C
No. of circuits		1	1	1	2	2	2	2	2	2	2	2	2
Capacity stages		50/100	40/100	50/100	25 / 50	20 / 40	25 / 50	29/57	31/63	33/67	25/50	17/33	17/33
					75 / 100	70 / 100	75 / 100	79/100	81/100	83/100	75/100	67/100	67/100
Operating weight	Kg	1340	1420	1480	1910	2210	2500	3000	3240	3220	3775	4135	4653
Shipping weight	Kg	1300	1380	1420	1860	2130	2360	2850	3100	3100	3653	3962	4376

Notes:

- (1) Rated in accordance with ARI Standard 550/590-03.
- (2) MCA Ratings (Minimum Circuit Ampacity) based on 380V / 60Hz.
- (3) Ratings based on global consumption (compressors and fans).
- (4) MCA Ratings (Minimum Circuit Ampacity) based on 380V / 50Hz.
- (5) Control panel width is included in the unit length
- (6) Control panel area is not included.
- (7) Compressor model refers to units with R22 (CGAD020-090). Models presented in this manual are up to the present time.
- (8) The adapters to Victaulic connection are not supplied in the standard option.
- (9) Operating Weight includes refrigerant and water weight.
- (10) Shipping Weight includes only refrigerant weight.

Selection Procedures

Liquid chiller capacity on table of performance adjust factors, show the most frequent leaving water temperatures. The table reflects a temperature drop of 5,5 °C (10°F) through the evaporator. For low temperature selections, check the tables for it.

To select a CGAD Air-Cooled Liquid Chiller Trane, the following information is required:

- 1 Thermal project load of project in tons of cooling.
- 2 Chilled water temperature project drop.
- 3 Leaving chilled water project temperature.
- 4 Project ambient temperature and refrigerant type.

The evaporator flow is determined through the following formulas:

$$\text{GPM} = \frac{\text{Tons} \times 24}{\text{Temperature drop (°F)}}$$

$$\text{L/s} = \frac{\text{kW (Capacity)} \times 0,239}{\text{Temperature drop (°C)}}$$

NOTE 1:

The flow should be within the limits specified in General Data table.

Note:

The selection above is an example for manual equipment selection. Please note that a more accurate data check is required for a correct selection.

Selection example:

Data:

- System load required= 70 Tons.
- Leaving chilled water temp. = 7°C
- Chilled water temperature drop = 5,5°C (10°F)
- Project ambient temperature = 35°C

- 1 Calculate the required chilled water flow using the formula below:

$$\text{GPM} = \frac{70 \text{ Tons} \times 24}{10^\circ\text{F}} = 168 \text{ GPM}$$
- 2 Using table 03 (Performance Data - R-22), a CGAD 080 unit at these conditions will output 76,2 Tons with a compressor consumption of 81,1 kW.

- 3 Determine the evaporator pressure drop using the flow and the evaporator water pressure drop curves, introducing the curve at 168 GPM, the pressure drop for an evaporator with the nominal value of 80 Tons is 9 ft, or 2,74 m.

- 4 For selection of low temperature units, or applications in which the altitude is significantly above sea level, or the temperature drop is different from 5,5 °C, contact a local Trane engineer for further information.

For example:

- Corrected capacity = Capacity (not adjusted) x Glycol Capacity Adjustment Factor
- Corrected Flow = Flow (not adjusted) x Glycol Flow Rate Adjustment Factor

- 5 The final unit selection is: CGAD 080B
 Refrigerant Type: R-22
 Cooling capacity =76,2 Tons.
 Entering temperatures = 12,5 °C
 Leaving chilled water temperature = 7°C
 Chilled water flow =168 GPM
 Evaporator pressure drop =2,74 m
 Compressor consumption = 81,1 kW

NOTE 2:

Minimum leaving chilled water temperature setpoint

The minimum leaving chilled water temperature setpoint is 4°C. For applications where a lower setpoint is required, a glycol solution must be used. Contact the local Trane engineer for further information.

Application Considerations

Unit Sizing

Unit capacities are listed in the Performance Data section. Intentionally over-sizing a unit to assure adequate capacity is not recommended. The excess in the system and compressor capacity calculation results in an over-sized liquid chiller. In addition, an oversized unit is usually more expensive to purchase, install and operate. If over-sizing is desired, consider using two units.

Unit Placement

1 Setting the Unit

2 Isolation and Sound Transmissions

The most effective isolation solution is to locate the unit away from any sound sensitive area. Structurally transmitted sound can be reduced by vibration eliminators. Spring isolators have proved to be of little efficiency in CGAD Air-Cooled Liquid Chiller installations and thus are not recommended. An acoustical engineer should always be consulted on applications with critical acoustic reduction levels.

For maximum isolation, water lines and electrical conduits should also be isolated. Wall sleeves and rubber-isolated piping hangers can be used to reduce the sound transmitted through water piping. To reduce the sound transmitted through electrical conduits, use flexible electrical conduits. State and local codes on sound emissions should always be considered. As the environment in which a sound source is located affects the sound pressure, unit placement must be carefully evaluated.

3 Unit Location

A General

Unobstructed airflow for the condenser is essential to assure efficient operation and the liquid chiller capacity. When determining unit placement, careful considerations must be given to assure enough air flow across the condenser heat-transfer surface.

Two conditions should be avoided in order to achieve optimum performance: warm air recirculation and coil starvation.

Warm air recirculation occurs when the airflow from the condenser fans discharged back at the condenser coil inlet, due to installation site restrictions. Coil starvation occurs when the free airflow

to the condenser coil is restricted. Both warm air recirculation and coil starvation cause reductions in unit efficiency and capacity, due to the associated high discharge pressures.

A - Provide Vertical Clearance

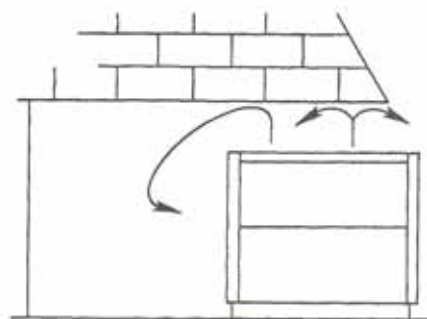

B - Provide Side Clearance

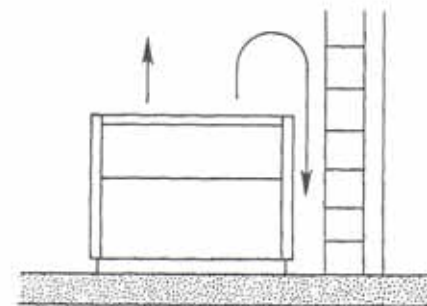

C - Provide enough clearance between devices

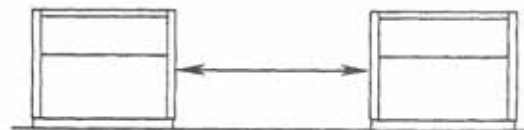

D - Installations in locations surrounded by walls

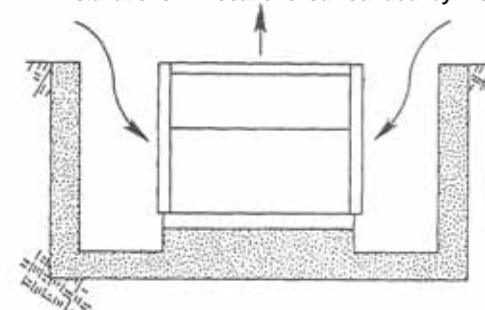

Application Considerations

Evaporator hydraulic piping components

The figure below shows how to proceed with the installation of the water piping. An air purge is placed on the evaporator and at the water outlet. Provide additional air purges at high piping points to release it from the chilled water system.

Evaporator Drain

The evaporator drain connection must be piped to an available strainer in order to drain the evaporator even during operation. Install a gate valve in the drain line.

Thermometers and Manometers

It is essential to install thermometers (items 5 and 12 in the figure) and manometers (item 9) at the chilled water inlet and outlet. These instruments must be installed close to the unit, with a maximum scale of 1°C for thermometers and 0,1 kgf/cm² for manometers.

Important: In order to avoid evaporator damages, do not exceed a 150-psig water pressure.

The manometer with connection should be installed at water inlet and outlet according to item 9 in the figure below in order to avoid reading mistakes. Manometers and thermometers must be installed at the appropriate height to avoid parallax errors*. Thermometers must be of glass or mercury-scale type, with colored contrasting fluid, and provide easy reading.

- Manometers must be equipped with siphons;
- Install gate valves to isolate the manometers when they are not being used.

Use piping joints to facilitate assembly and disassembly services.

Inlet and outlet must be equipped with gate valves to isolate the evaporator during service, and a globe valve must be installed at the outlet to adjust the water flow.

Flow-Switch

Verify that safety interlockings, particularly the flow-switch, are installed in straight and horizontal runs, with vanes adequate to the pipe diameter, and the distance from curves and valves must be at least 5 times its diameter, on each side.

Water treatment

The use of untreated or improperly treated water may result in scaling, erosion, corrosion, algae and slime. The services of a qualified water treatment specialist should be engaged to determine what treatment, if any, is advisable. Trane do Brasil assumes no responsibility for equipment failures resulting from the use of untreated or improperly treated water.

Fig. 01 - Evaporator hydraulic piping components

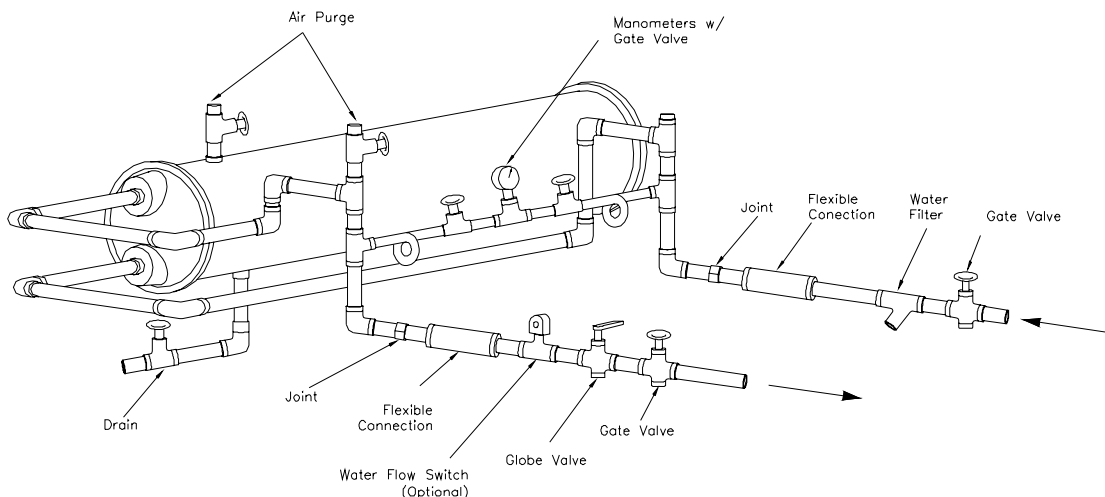

* Parallax error: Apparent displacement of an object, when the observation point changes. It is especially said of the apparent deviation of a measure instrument needle, when it is not observed from a vertical point of view (parallax error).

Performance Adjustment Factors

Fig. 02 - Evaporator Pressure Drop - 20 to 60 Tons Units

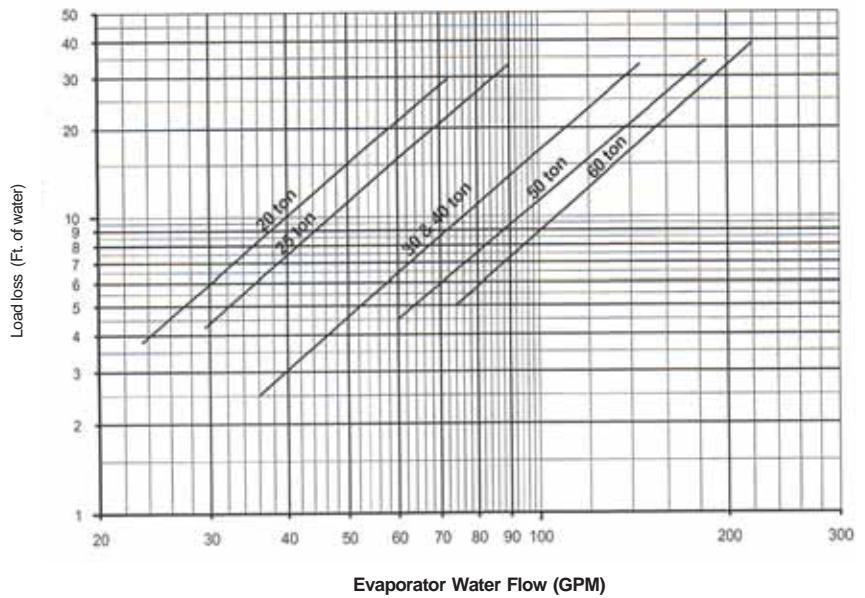

Unit Conversion

From:	To:	Multiplier:
Gallons/min (GPM)	L/s	0.06308
Feet of water (Ft Water)	Pa	2900

Fig. 03 - Evaporator Pressure Drop - 70 to 90 Tons Units

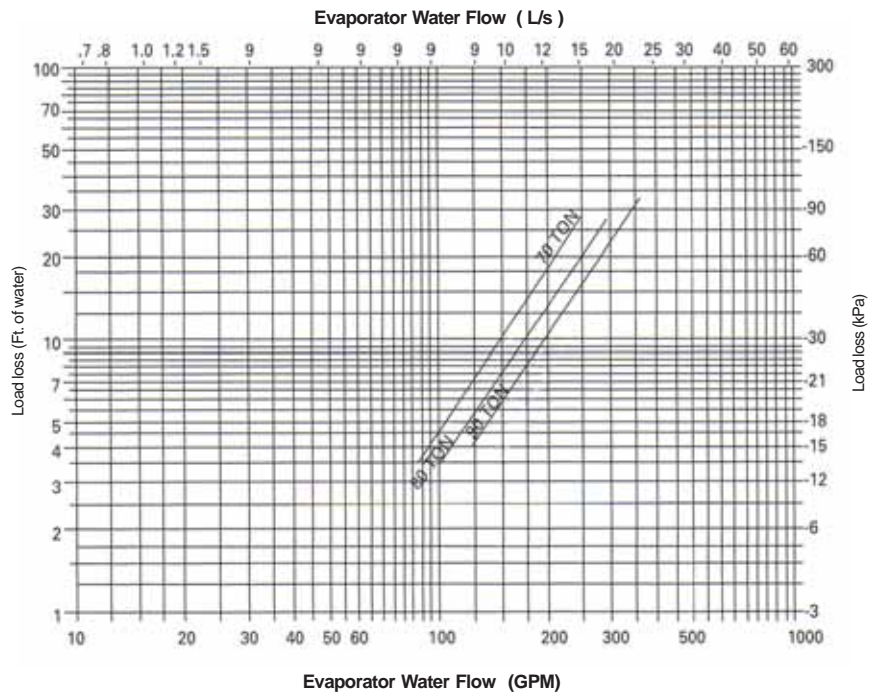



Performance Adjustment Factors

Fig. 04 - Evaporator Pressure Drop - 100 to 120 Tons Units

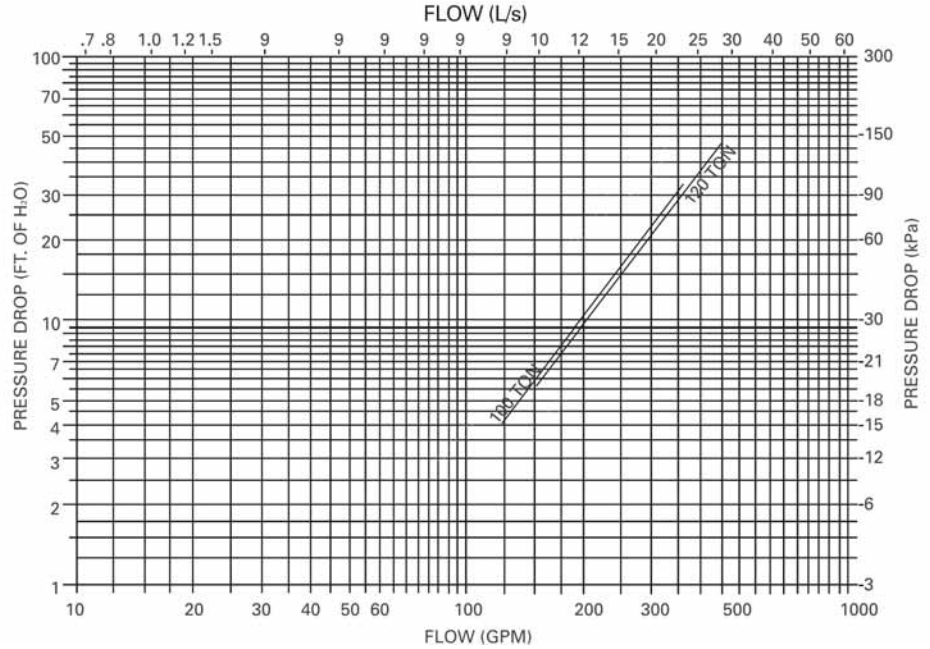

Conversão de Unidades

De:	Para:	Multiplicador:
Galões/min (GPM)	L/s	0,06308
Pés de Água (Ft. Água)	Pa	2990

Fig. 05 - Evaporator Pressure Drop - 150 Tons Units

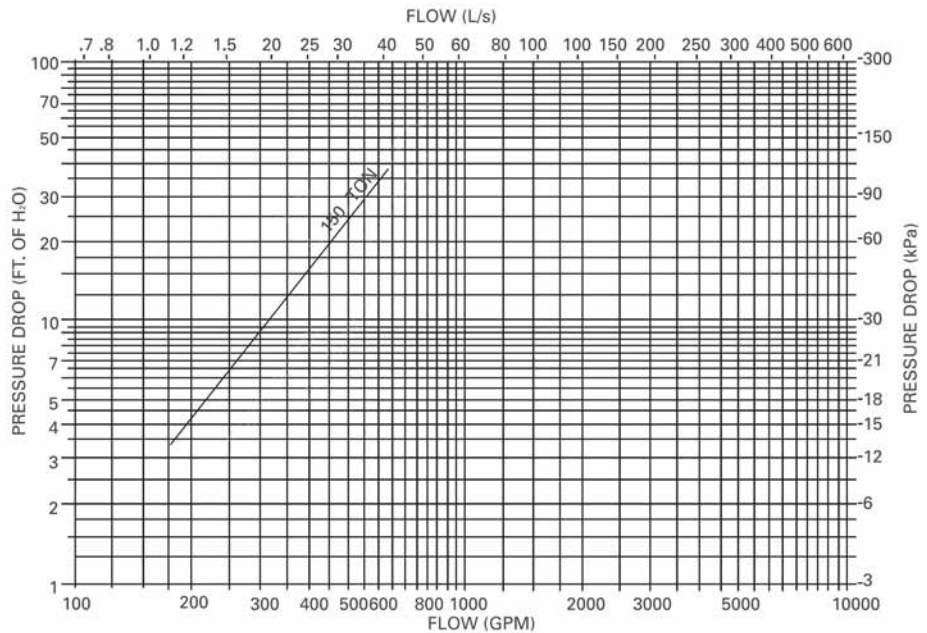

Performance Adjustment Factors

Fig. 06 - Ethylene Glycol Performance Factors

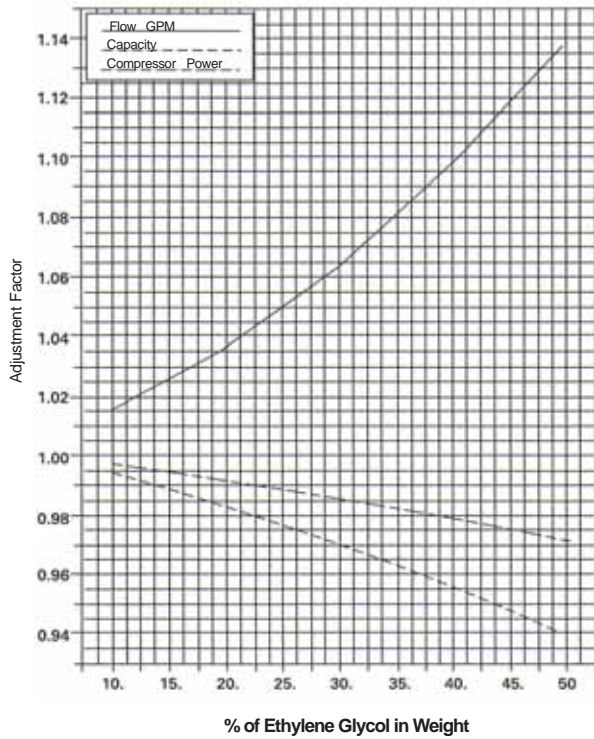
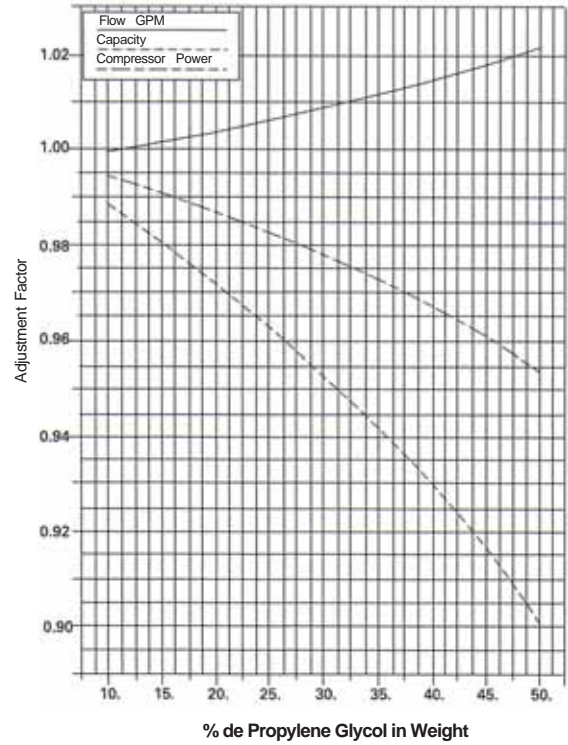

Fig. 07 - Propylene Glycol Performance Factors



Tab. 02 - Altitude Correction Factors

Altitude	Capacity	Consumption	Water Flow
0	1,000	1,000	1,000
500	0,997	1,012	0,997
1000	0,994	1,024	0,994
1500	0,991	1,037	0,991
2000	0,987	1,052	0,987
2500	0,983	1,067	0,983
3000	0,978	1,084	0,978

Fig. 08 - Ethylene and Propylene Freezing Points

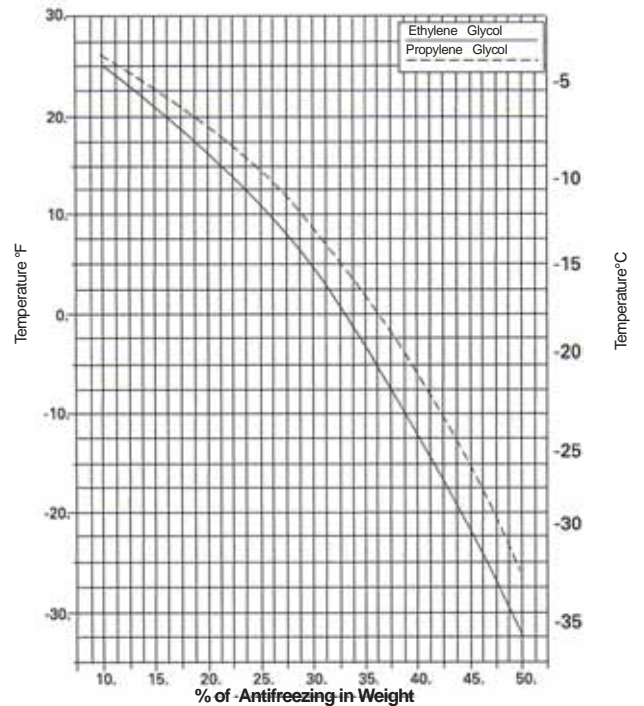

Acoustic Pressure Levels

Tab. 07 - Cooled liquid CGAD series.

Equipment	Acoustic Pressure (dbA) of 10 meters
CGAD020C	64
CGAD025C	65
CGAD030C	65
CGAD040C	67
CGAD050C	68
CGAD060C	68
CGAD070C	70
CGAD080C	72
CGAD090C	72
CGAD100C	72
CGAD120C	74
CGAD150C	74

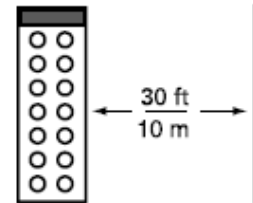

Notes: Measurements are made on the side of equipment at distance of 10 meters. Measurements smaller than 10 meters may provide different results because of the large size of equipment and different sources of noise located in different positions.

Controls

Control Module

Trane do Brasil makes the latest microprocessor control technology available to its clients. The CH530 controller with the DynaView control module. The DynaView has a touch sensitive liquid crystal display which gives the user access to all information about configuration, operating mode, temperatures, electrical data, pressures and diagnostics.



Safety Controls

The controller also provides a high level of protection for the equipment, by constantly monitoring the evaporator and condenser pressure, current, voltage and temperature variables. When one of these variables approaches a limit which could cause the unit to switch off, the controller starts a number of actions, such as stepping the compressors and fans, in order to keep the equipment working before taking the final decision to take it out of service. In normal operation, the controller will always optimize the unit's operation by stepping the compressors and fans so as to ensure the best energy efficiency level for the equipment operating conditions.

External Controls

The controller provides a number of different controls using external signals, thus making equipment operation more flexible.

Remote On/ Off - The unit can be switched on or off remotely by means of an NC (normally closed) contact or switch..

Water Pump Interlock -The equipment will be notified if there is water flow in the evaporator by means of an auxiliary contact in the water pump contactor and a flow switch.

Water Pump Control -The controller has an output to activate the evaporator water pump contactor; an external control is therefore not required to activate it.

Hot Gas Bypass Valve Control- When the Hot Gas Bypass valve option is requested, the controller has an output for operating the valve based on the operational information which the user sets in the DynaView controller.

Emergency Stop - An NC contact or external switch can be used to switch the unit off in emergencies. The unit must then be restarted manually using the DynaView. This facility allows the unit to be switched off by a fire alarm system, for example.

Optional Controls

Trane also offers an extremely wide range of controls which are intended for applications specific to individual installations.

Remote Adjustment of the Chilled Water Setpoint

The chilled water setpoint can be controlled remotely by means of an analog input, using a 0-10VDC or 4-20mA signal.

Signalling Relays

A set of 4 programmable relays can be used for remote signaling of the unit's operational status, such as maximum capacity, operation at the limit, compressors in operation and alarm signaling.

Ice Making and Demand Control

The equipment can be put into ice making mode externally by means of an NO (normally open) contact. Unit demand control can be carried out by means of an NC (normally closed) contact in another of this module inputs.

COMM3 Interface- This interface will enable the equipment to be interconnected to the Trane Tracer Summit control and management system.



Controls

Protections and Operational Functions

Operational Protection Measures and Functions - The main operational protection measures and functions available are described below:

Compressor Internal Thermostats - Trane compressors have internal thermostats to protect the motor windings, which are constantly monitored by the controller.

Inversion and No Phase
The controller monitors the phase sequence and the presence of current in each phase by means of current sensors installed in each of the supply phases.

Overload Relay
The supply for each compressor is via an overload relay, which is constantly monitored by the controller, which turns the compressor off when an overload is detected.

Balancing Starts / Operating Hours
The controller optimizes the start sequence for the compressors by balancing the number of starts and the number of hours for each compressor, and does not allow one compressor to have a greater operating regime than the others.

Evaporator Water Flow
A suitable flow switch must be installed and electrically connected to the controller in order to report water flow in the evaporator. This ensures that the equipment either does not go into operation or is shut down if there is no water flow.

Anti-freeze Protection
The controller monitors the leaving water temperature and will disable the compressors when the water temperature reaches the set cutout temperature.

High Pressure Protection
The controller constantly monitors the pressure regulator installed in the equipment discharge line and shuts the circuit down when pressure greater than the set maximum is detected.

Low Pressure Limit
The controller will restrict the operation of the compressors, by switching them off or not allowing other compressors to start, when the suction pressure approaches the set cutout pressure.

External Temperature Cutout - Operation of the equipment can be controlled by the temperature of the outdoor air, i.e. the equipment will only go into operation when the outdoor air temperature is above the temperature set in the controller. If the equipment is working, it will be switched off when the outdoor air temperature reaches the set temperature.

Automatic Adjustment of the Chilled Water Setpoint - The controller can provide automatic adjustment of the chilled water temperature setpoint based on the outdoor air temperature or on the return temperature of the water. This kind of adjustment offers better ambient temperature comfort control, as well as providing energy savings and allowing the customer to find the best system control point.

Capacity Limiting during Starting - When the equipment goes into operation and the leaving water temperature is above 19°C, the controller will not allow the second compressor to go into operation until the leaving water temperature drops below 19°C. This prevents the equipment from being switched off due to high discharge pressure because of compressor overload.

Starting in Cold Areas
When the equipment is installed in a location where the ambient or outdoor temperature is low, there is a possibility that the equipment will be switched off because of low pressure before there is enough condensing pressure to send the refrigerant back to the evaporator. Therefore, cutout due to low pressure will be ignored for a period; this period will vary according to the outdoor temperature at the location.

Operational Recovery and Service Recovery
In equipment with reciprocating compressors, recovery ensures that, when started again, the liquid left in the evaporator is not sucked in by the compressor, thus damaging it. Unlike reciprocating ones, scroll compressors tolerate flood back. However, when required, operational recovery of the refrigerant after the equipment or circuit in operation has stopped can be undertaken. In order to be able to use this function the equipment must be equipped with solenoid valves in the liquid line. The purpose of service recovery is to recover the refrigerant into the condenser so that maintenance work can be carried out. This recovery can only be done manually from the controller. Optional valves in the compressors suction and discharge can be requested.

Controls

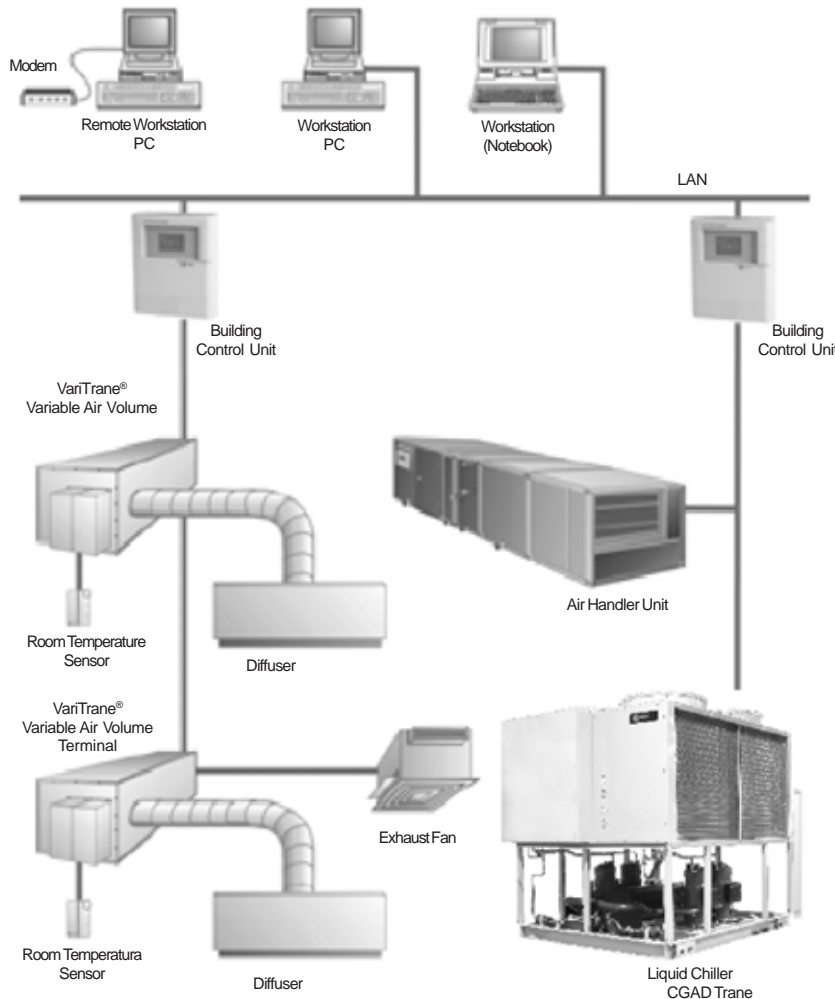

The owner of an establishment or building can monitor the chiller fully from the Tracer system, as all the monitoring information shown on the unit controller can be read from the Tracer system display. Furthermore, all the diagnostic information can be read in the tracer system. Best of all, these powerful features are achieved with only one twisted pair of wires. The chillers can interface to a range of external control systems, from simple independent units to ice making systems.

A single twisted pair of wires connected directly between the chiller and a Tracer Summit system provides control, monitoring and diagnostic capabilities. Control functions include switch on/ switch off, adjustment of the leaving water temperature setpoint, blocking compressor operation for demand limiting and control of ice making mode. The Tracer system reads the monitoring information, such as entering and leaving evaporator water temperatures and outdoor temperature. The Tracer system can read a large number of individual diagnostics on equipment being controlled/ monitored. In addition to this, it can provide sequencing control for up to 25 units on the same system.

Required Options

COMM3 Communications Interface

Required Devices

Building Control Unit (BCU) and Tracer Summit management software.

Tracer Summit - Trane Integrated Comfort System (ICS)

The Tracer Summit Building Management System with Chiller Control provides building automation and energy management functions using independent control. The Chiller Control is able to monitor and control the complete installed chiller system.

Available applications:

- . Time programmer;
- . Demand limiter
- . Chiller sequencing
- . Process control language.
- . Boolean processing.
- . Ambient controllers
- . Reports and logs
- . Personalized messages

- . Operating and maintenance time
- . Trend log
- . PID control loop

Of course, Trane Chiller Control can also be used independently or in conjunction with a complete building automation system.

When one or more chillers are used with a Tracer Summit system from Trane, the units can be monitored and controlled from a remote location.

The chillers can fit into a global building automation strategy by using scheduling, programmed changes, demand limiting and chiller sequencing.

Controls

Ice Making System Controls

The ice making option can be requested with the chiller. The unit will have two operating modes, ice making and normal chilling. In ice making mode the chiller will operate at total compressor capacity until the return solution temperature matches the setpoint for ice making. The chiller needs two input signals. The first is an on/off signal for scheduling and the second is required to switch the unit between ice making mode and normal operation. The signals are supplied by a remote building automation device, such as, for example, a timer or a manual switch. The signals can also be supplied by the Tracer System.

Additional Options which Can Also Be Used

- Signalling Relays

Further Tracer Summit Characteristics- Trane Chiller Systems Automation

Trane's experience in chillers and controls makes us the preferred choice for chiller automation. The Tracer Summit building automation system from Trane has chiller control capabilities which are unparalleled in the industry. Our chiller automation software is fully developed and tested by Trane.

Energy Efficiency

Trane chiller automation manages chiller starts so as to optimize the total energy efficiency of the equipment. Sophisticated software automatically determines which chiller should be operating in response to the current conditions. The software also switches automatically between individual

chillers in order to ensure equal operating time and wear between chillers.

Trane chiller automation allows unique strategies for energy saving. An example is the control of pumps and chillers based on a view of the total energy consumption of the system. The software intelligently evaluates and selects the option with least energy consumption.

Keeping Operators Informed

It is vital for efficient chiller operation to ensure that operational personnel have instant information on what is happening in the equipment. By clearly describing the chiller system, drawings with schematic layouts of chillers, tubing, pumps and towers allow building operational staff to monitor all the conditions efficiently. Status screens show the current conditions and control actions which have to be taken in order to increase or decrease chiller capacity.

Chillers can be monitored and controlled from a remote location. The Tracer Summit provides standardized report templates which list key operational data for problem solving and performance checking. The reports for each type of chiller and for chiller sequencing systems are also standardized. Detailed reports with chiller operating times help in planning preventive maintenance.

Rapid Response in Emergencies

We appreciate the importance of maintaining chilled water production and at the same time protecting your chillers from expensive damage. If water flow into a

chiller's tubing is not detected, the start sequence is interrupted in order to protect the chiller and the next chiller within the sequence is immediately started up to maintain chilling. Should a problem occur, the operator receives an alarm warning and a diagnostic message to help solve the problem quickly and accurately. An instant report showing the system status immediately before it was switched off helps operators identify the cause. If the emergency conditions warrant an immediate manual shutdown the operator can ignore the automatic control.

Documentation

The comprehensive documentation covering chiller management practices is now a fact of life. Trane chiller system automation generates the reports defined in the ASHRAE Guidelines.

ICS or Integrated Comfort System Capabilities

When it is integrated with a tracer Summit management system, Trane chiller automation manages the coordination with the Tracer Summit applications in order to optimize global building operation. With this system option, a large part of Trane's HVAC* and control experience is used to provide solutions for different parts of the installation. If your project requires an interface to other systems the Tracer Summit system can share data using BACNet, the ASHRAE open systems protocol, MODBUS and other protocols (subject to confirmation).

*HVAC = Heating, Ventilation and Air Conditioning.



Electrical Data

Tab. 08 - Electrical Data - 60 Hz

Modelos	Componentes	60 Hz											
		Nominal Current (A)	220V Start Current(A)	MCA	Fuse	Nominal Current (A)	380V Start Current(A)	MCA	Fuse	Nominal Current (A)	440V Start Current(A)	MCA	Fuse
CGAD020	Compresores	65,2				38,4				30,3			
	Fans	8,2	310,0	88,0	125,0	4,7	183,0	54,0	70,0	4,2	143,0	45,0	60,0
	Total	73,4				43,1				34,5			
CGAD025	Compresores	78,9				47,8				37,7			
	Fans	12,3	328,0	110,0	150,0	7,1	195,0	68,0	100,0	6,3	153,0	57,0	80,0
	Total	91,2				54,8				44,0			
CGAD030	Compresores	92,5				57,2				45,1			
	Fans	12,3	443,0	135,0	175,0	7,1	275,0	78,0	100,0	6,3	208,0	65,0	80,0
	Total	104,8				64,2				51,4			
CGAD040	Compresores	130,4				76,7				60,5			
	Fans	16,4	383,0	163,0	200,0	9,4	226,0	97,0	110,0	8,4	178,0	80,0	90,0
	Total	146,8				86,1				68,9			
CGAD050	Compresores	157,7				95,5				75,4			
	Fans	24,6	419,0	209,0	250,0	14,1	250,0	123,0	150,0	12,6	197,0	110,0	125,0
	Total	182,3				109,6				88,0			
CGAD060	Compresores	185,0				114,4				90,2			
	Fans	24,6	547,0	230,0	300,0	14,1	339,0	142,0	175,0	12,6	259,0	116,0	150,0
	Total	209,6				128,5				102,8			
CGAD070	Compresores	222,9				133,9				105,6			
	Fans	24,6	624,0	270,0	300,0	14,1	367,0	163,0	200,0	12,6	287,0	130,0	150,0
	Total	247,5				148,0				118,2			
CGAD080	Compresores	250,2				152,7				120,5			
	Fans	32,8	761,0	310,0	350,0	18,8	461,0	192,0	200,0	16,8	354,0	150,0	175,0
	Total	283,0				171,5				137,3			
CGAD090	Compresores	277,6				171,5				135,3			
	Fans	32,8	889,0	330,0	400,0	18,8	550,0	210,0	225,0	16,8	416,0	170,0	200,0
	Total	310,4				190,3				152,1			
CGAD100	Compresores	359,0				213,2				157,4			
	Fans	36,3	870,0	425,0	500,0	21,0	490,0	255,0	300,0	16,5	409,0	190,0	225,0
	Total	395,3				234,2				173,9			
CGAD120	Compresores	426,4				251,7				187,3			
	Fans	48,4	1257,0	500,0	500,0	28,0	720,0	295,0	300,0	22,0	581,0	225,0	250,0
	Total	474,8				279,7				209,3			
CGAD150	Compresores	538,6				319,7				236,7			
	Fans	60,5	1545,0	630,0	700,0	35,0	863,0	376,0	400,0	27,5	730,0	284,0	300,0
	Total	599,1				354,7				264,2			

Tab. 09 - Electrical Data - 50 Hz

Modelos	Componentes	50 Hz			
		Nominal Current (A)	380V Start Current(A)	MCA	Fuse
CGAD020	Compresores	29,7			
	Fans	4,4	143,0	45,0	60,0
	Total	34,1			
CGAD025	Compresores	37,8			
	Fans	6,6	154,0	57,0	80,0
	Total	44,4			
CGAD030	Compresores	45,9			
	Fans	6,6	209,0	65,0	80,0
	Total	52,5			
CGAD040	Compresores	59,3			
	Fans	8,8	177,0	80,0	90,0
	Total	68,1			
CGAD050	Compresores	75,6			
	Fans	13,2	198,0	110,0	125,0
	Total	88,8			
CGAD060	Compresores	91,9			
	Fans	13,2	261,0	116,0	150,0
	Total	105,1			
CGAD070	Compresores	105,3			
	Fans	13,2	287,0	130,0	150,0
	Total	118,5			
CGAD080	Compresores	121,5			
	Fans	17,6	355,0	150,0	175,0
	Total	139,1			
CGAD090	Compresores	137,8			
	Fans	17,6	418,0	170,0	200,0
	Total	155,4			
CGAD100	Compresores	156,7			
	Fans	14,7	406,0	190,0	225,0
	Total	171,4			
CGAD120	Compresores	185,3			
	Fans	19,6	577,0	225,0	250,0
	Total	204,9			
CGAD150	Compresores	235,0			
	Fans	24,5	726,0	284,0	300,0
	Total	259,5			

NOTES:

- (1)Values of operation conditions are based on ARI 590-92
- (2)MCA: Minimum Circuit Ampacity

Dimensional Data

CGAD020

Fig. 09 - Unit Dimensions - CGAD 020

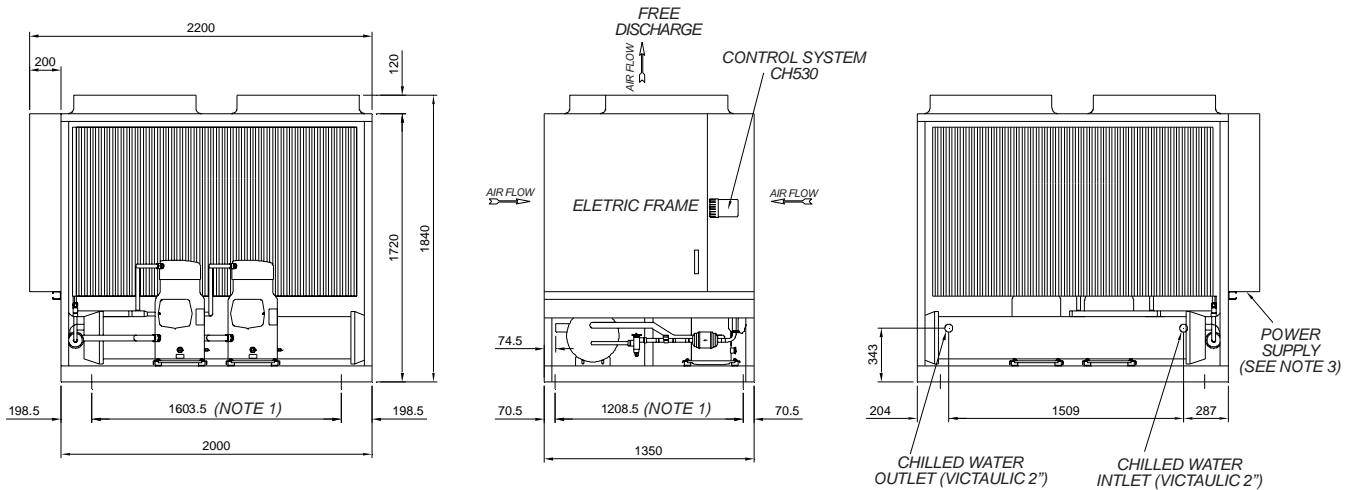

NOTES:

- 1 - FIXING POINTS FOR VIBRATION INSULATORS (4 X 13mm DIAM HOLES)
- 2 - VIBRATION INSULATORS ARE NOT SUPPLIED WITH THE EQUIPMENT.
- 3 - THE ORIFICE FOR ENTRY OF ELECTRICAL CABLES SHOULD BE CARRIED OUT IN THE FIELD BY THE INSTALLER.
- 4 - UNITS : mm

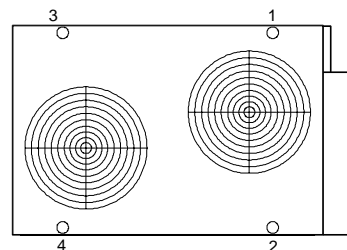
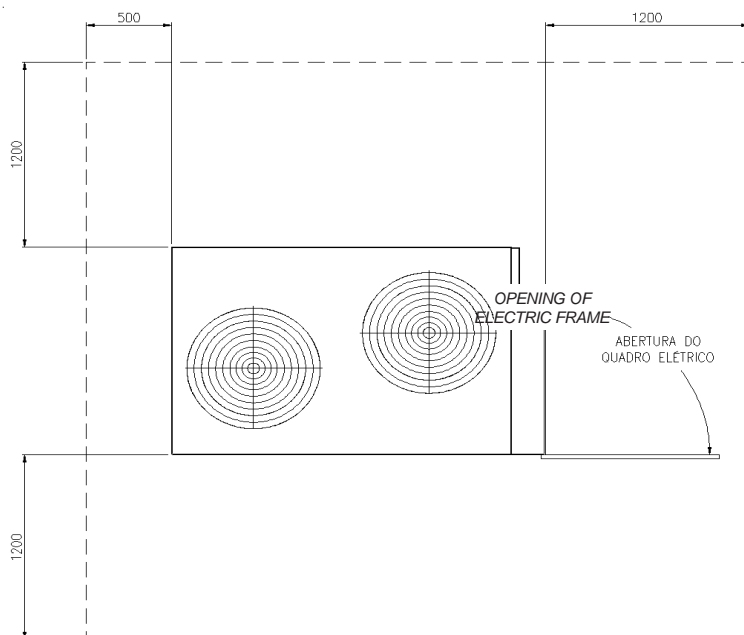

Fig. 10 - Maintenance and air circulation clearances



Dimensional Data

CGAD025

Fig.11 - Unit Dimensions - CGAD 025

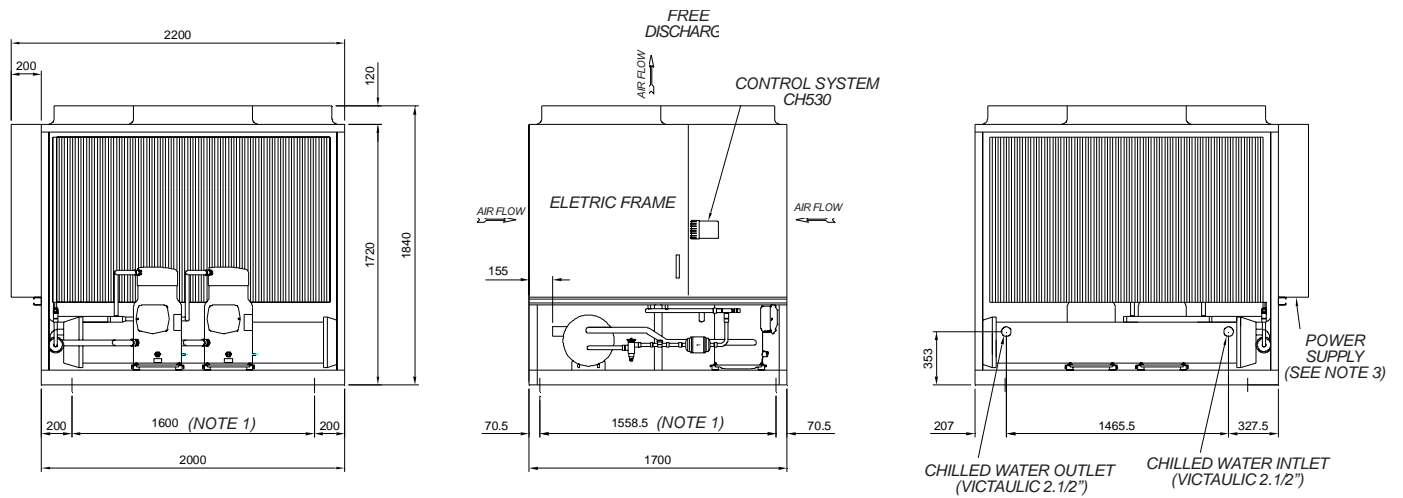

NOTES:

- 1 - FIXING POINTS FOR VIBRATION INSULATORS (4 X 13mm DIAM HOLES)
- 2 - VIBRATION INSULATORS ARE NOT SUPPLIED WITH THE EQUIPMENT.
- 3 - THE ORIFICE FOR ENTRY OF ELECTRICAL CABLES SHOULD BE CARRIED OUT IN THE FIELD BY THE INSTALLER.
- 4 - UNITS : mm

Fig. 12 - Maintenance and air circulation clearances

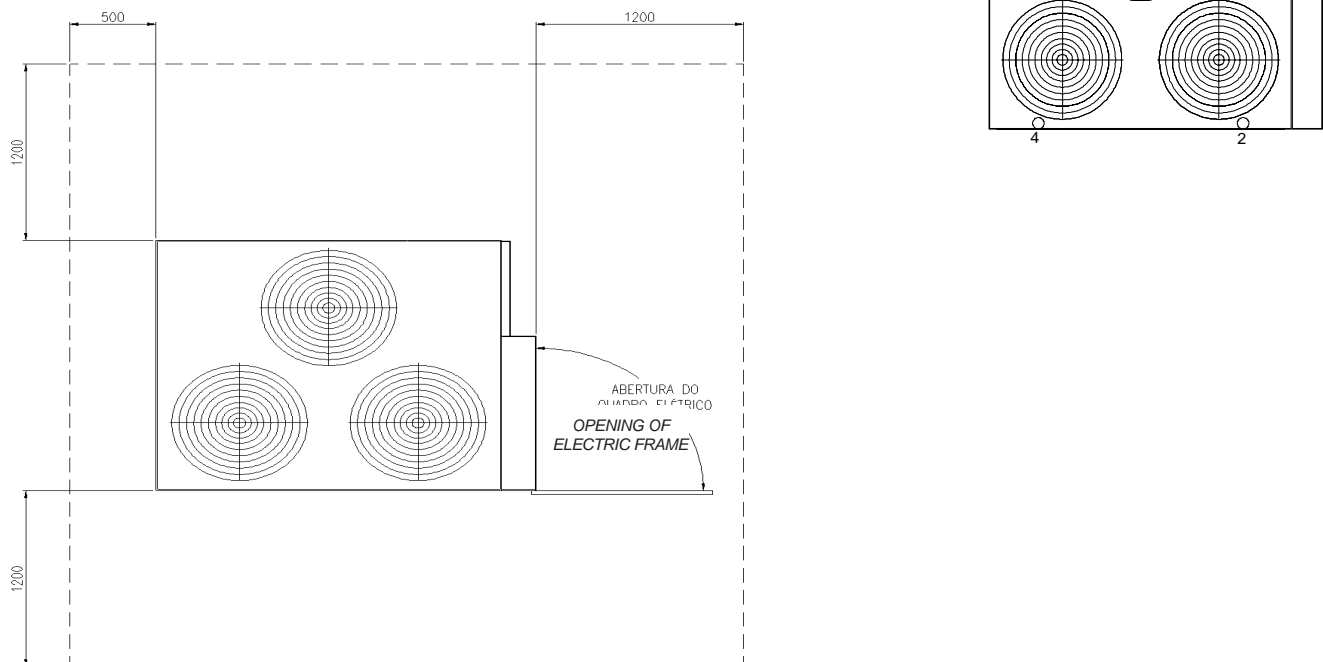

Dimensional Data

CGAD030

Fig.13 - Unit Dimensions - CGAD 030

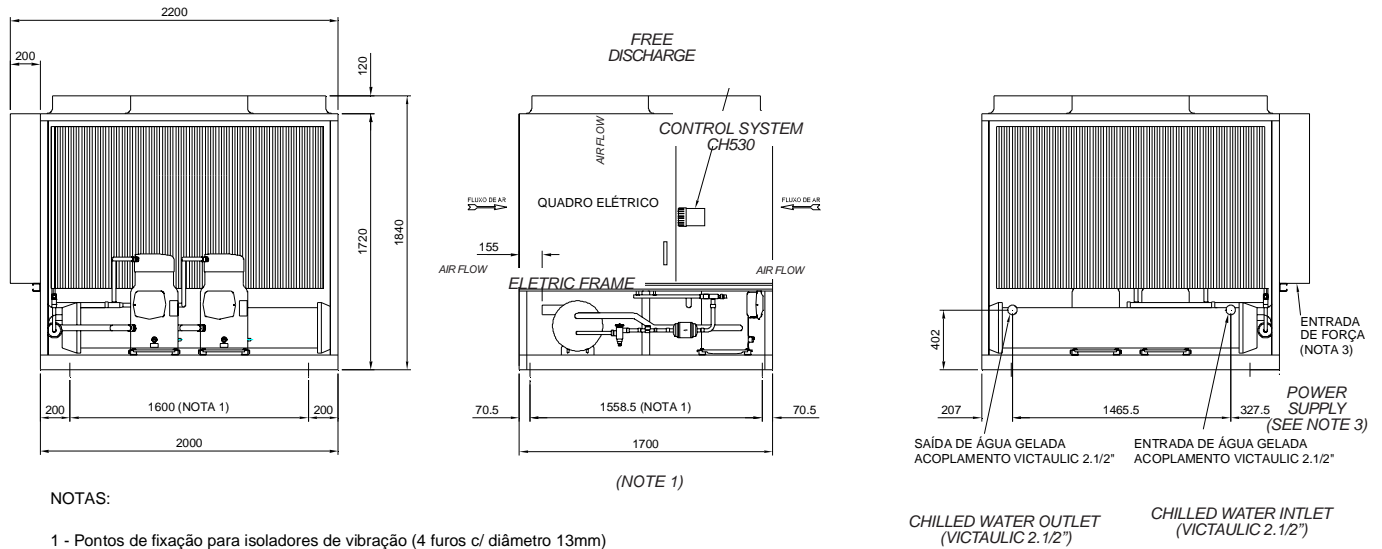
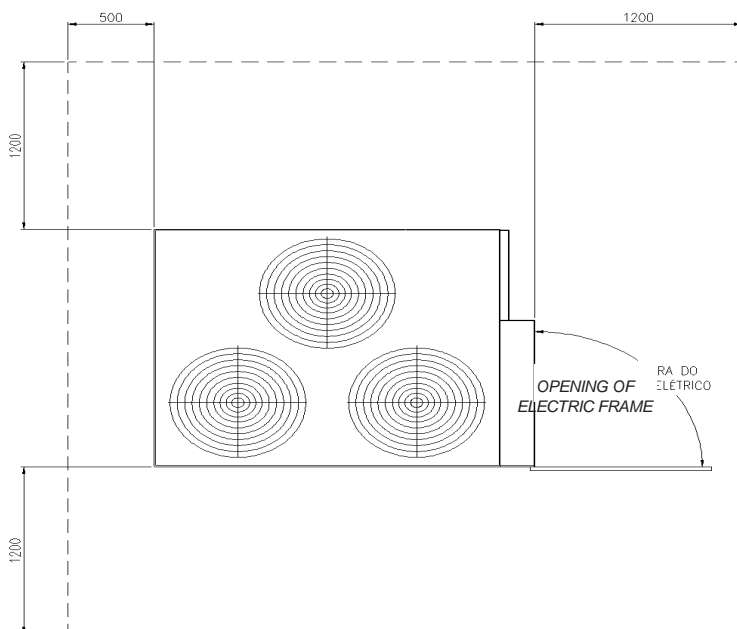

Fig. 14 - Maintenance and air circulation clearances



Dimensional Data

CGAD 040

Fig. 15 - Unit Dimensions - CGAD 040

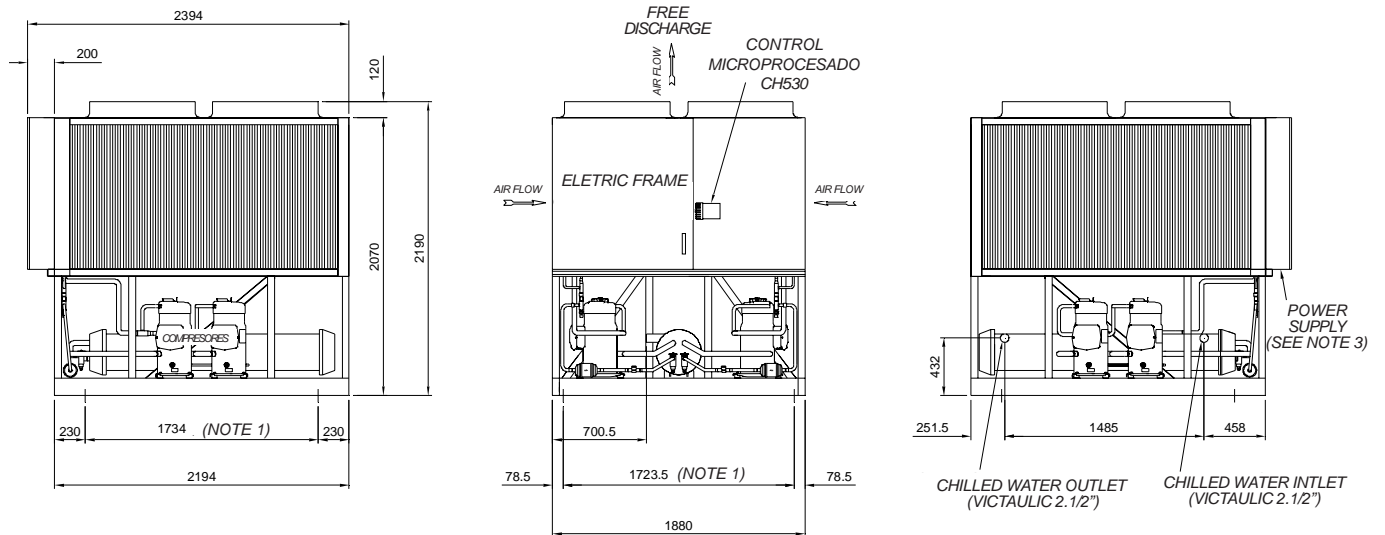

- NOTES:
- 1 - FIXING POINTS FOR VIBRATION INSULATORS (4 X 13mm DIAM HOLES)
 - 2 - VIBRATION INSULATORS ARE NOT SUPPLIED WITH THE EQUIPMENT.
 - 3 - THE ORIFICE FOR ENTRY OF ELECTRICAL CABLES SHOULD BE CARRIED OUT IN THE FIELD BY THE INSTALLER.
 - 4 - UNITS : mm

Fig. 16 - Maintenance and air circulation clearances

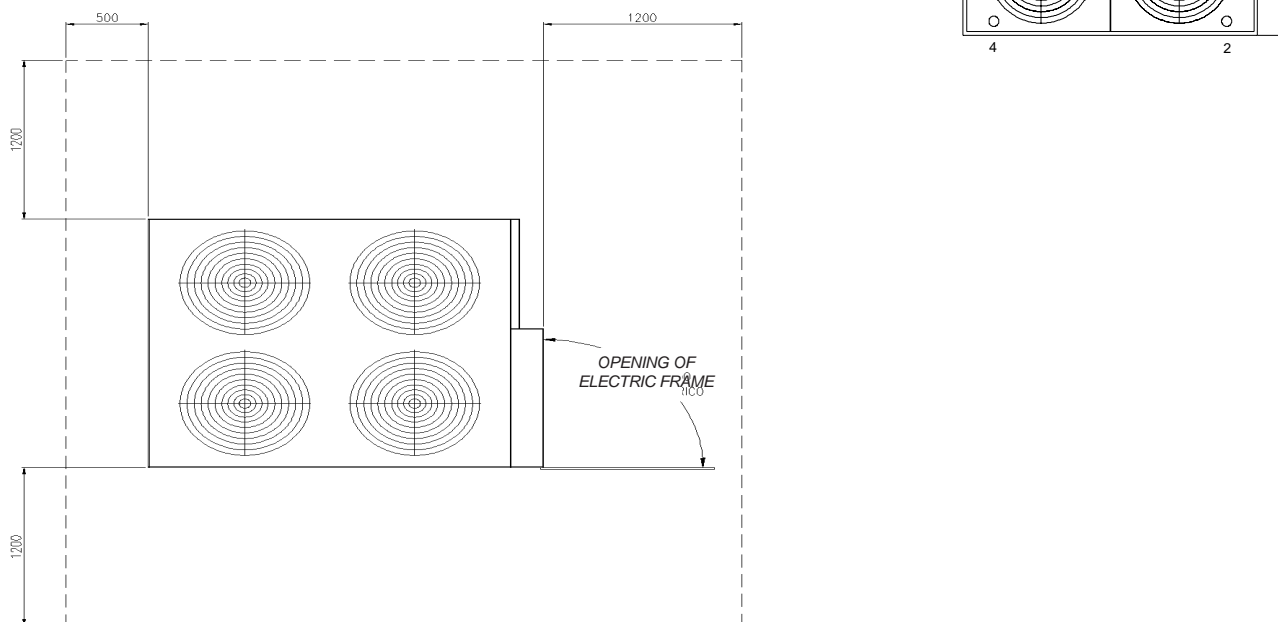

Dimensional Data

CGAD 050

Fig. 17 - Unit Dimensions - CGAD 050

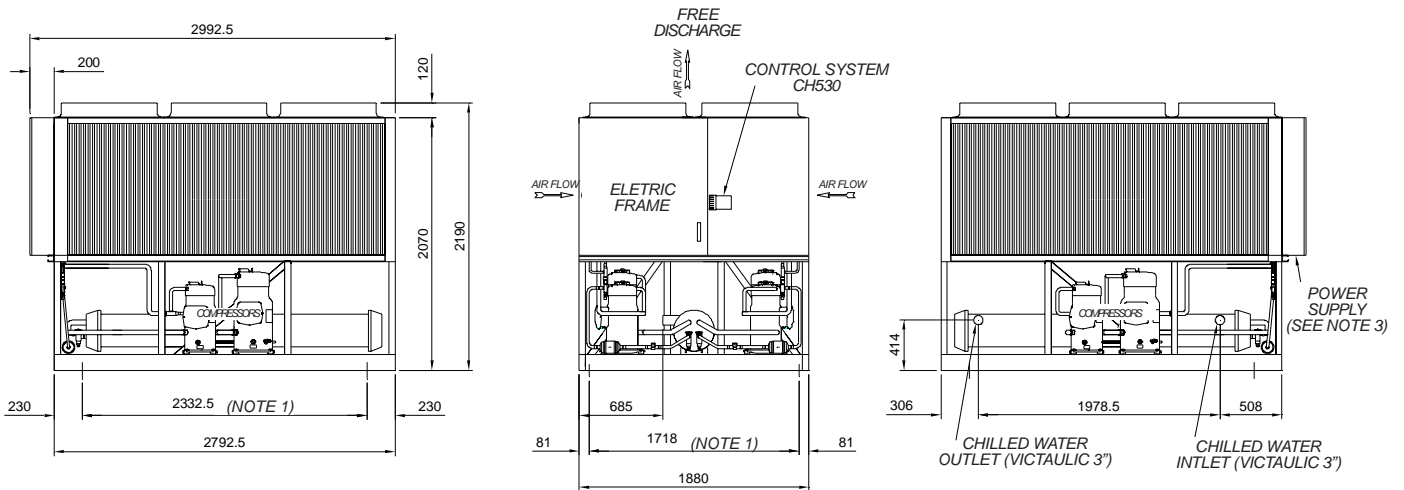

- NOTES:
- 1 - FIXING POINTS FOR VIBRATION INSULATORS (4 X 13mm DIAM HOLES)
 - 2 - VIBRATION INSULATORS ARE NOT SUPPLIED WITH THE EQUIPMENT.
 - 3 - THE ORIFICE FOR ENTRY OF ELECTRICAL CABLES SHOULD BE CARRIED OUT IN THE FIELD BY THE INSTALLER.
 - 4 - UNITS : mm

Fig. 18 - Maintenance and air circulation clearances

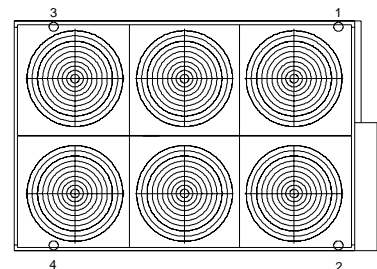
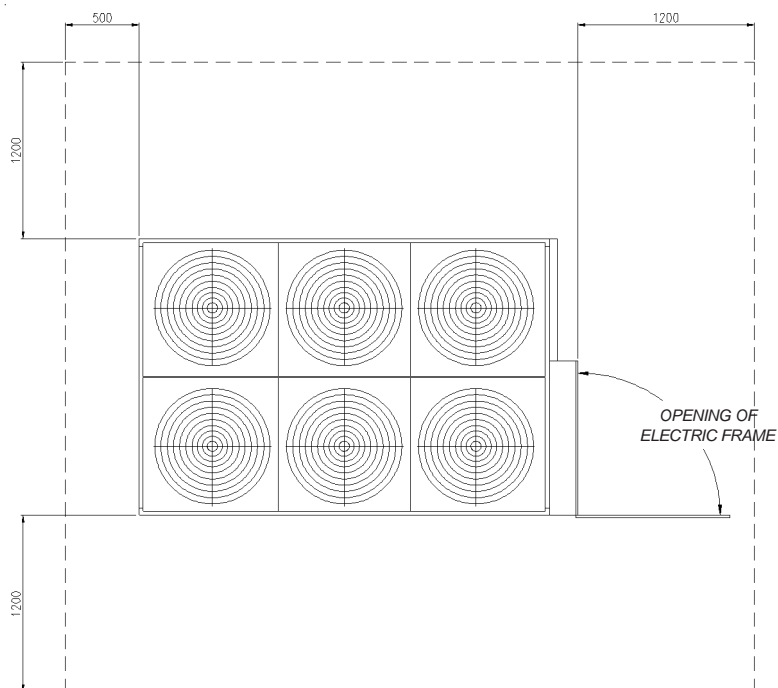

Dimensional Data

CGAD 060

Fig. 19 - Unit Dimensions - CGAD 060

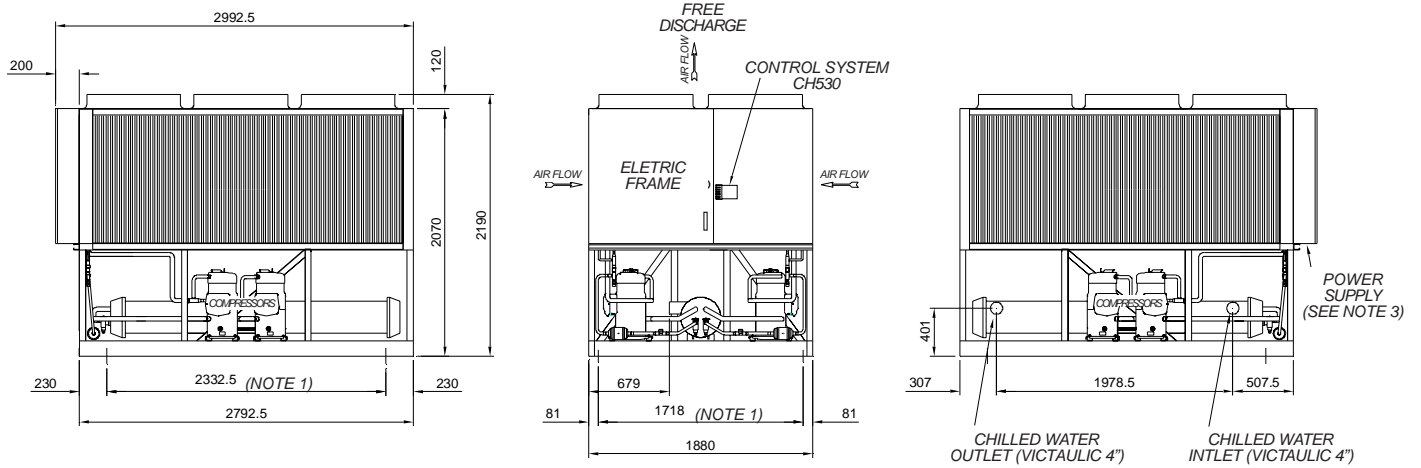

- NOTES:
- 1 - FIXING POINTS FOR VIBRATION INSULATORS (4 X.13mm DIAM HOLES)
 - 2 - VIBRATION INSULATORS ARE NOT SUPPLIED WITH THE EQUIPMENT.
 - 3 - THE ORIFICE FOR ENTRY OF ELECTRICAL CABLES SHOULD BE CARRIED OUT IN THE FIELD BY THE INSTALLER.
 - 4 - UNITS : mm

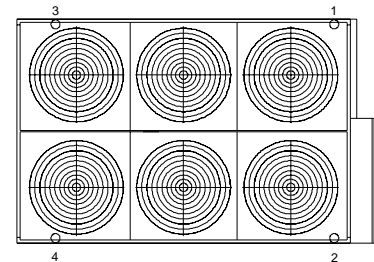
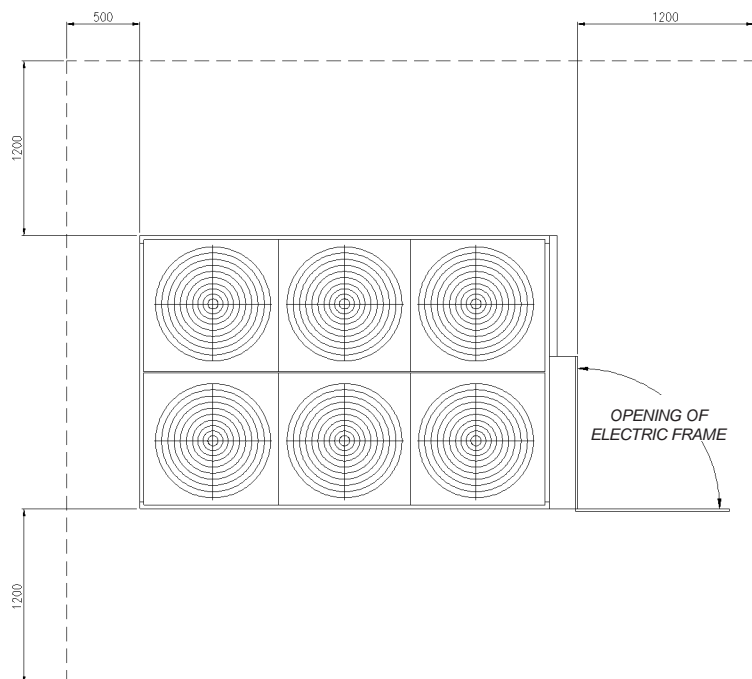

Fig. 20 - Maintenance and air circulation clearances



Dimensional Data

CGAD 070

Fig. 21 - Unit Dimensions - CGAD 070

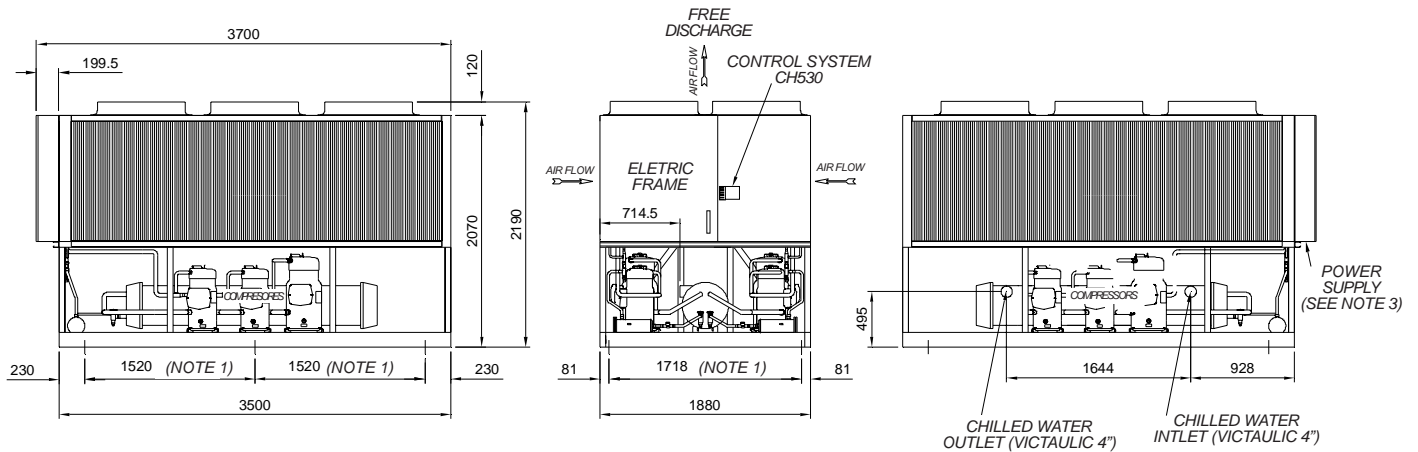

- NOTES:
- 1 - FIXING POINTS FOR VIBRATION INSULATORS (6 X 13mm DIAM HOLES)
 - 2 - VIBRATION INSULATORS ARE NOT SUPPLIED WITH THE EQUIPMENT.
 - 3 - THE ORIFICE FOR ENTRY OF ELECTRICAL CABLES SHOULD BE CARRIED OUT IN THE FIELD BY THE INSTALLER.
 - 4 - UNITS : mm

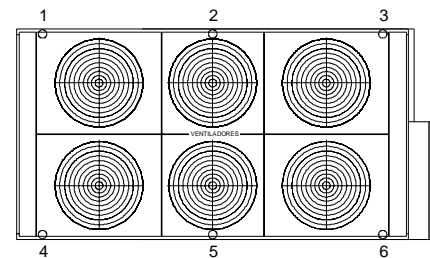
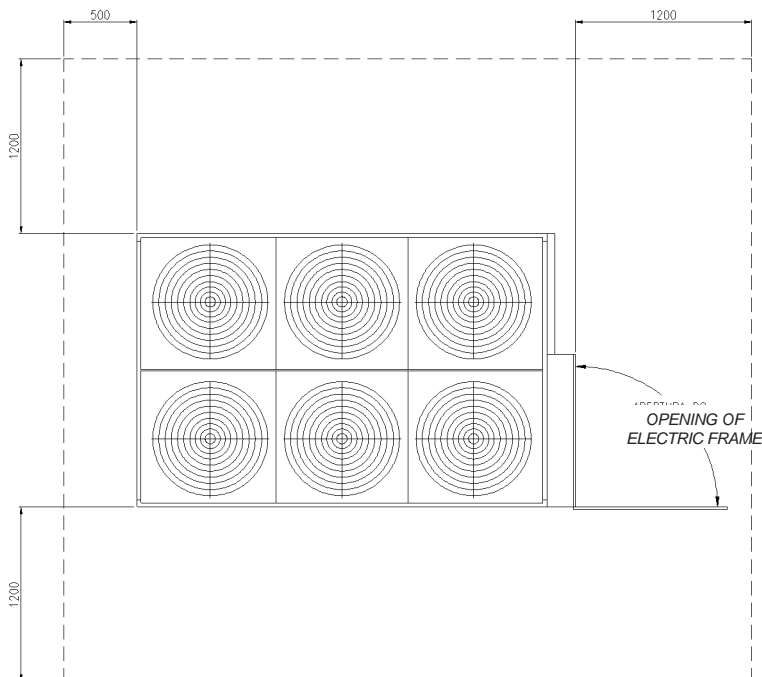

Fig. 22 - Maintenance and air circulation clearances



Dimensional Data

CGAD 080

Fig. 23 - Dimensiones de la Unidad CGAD 080

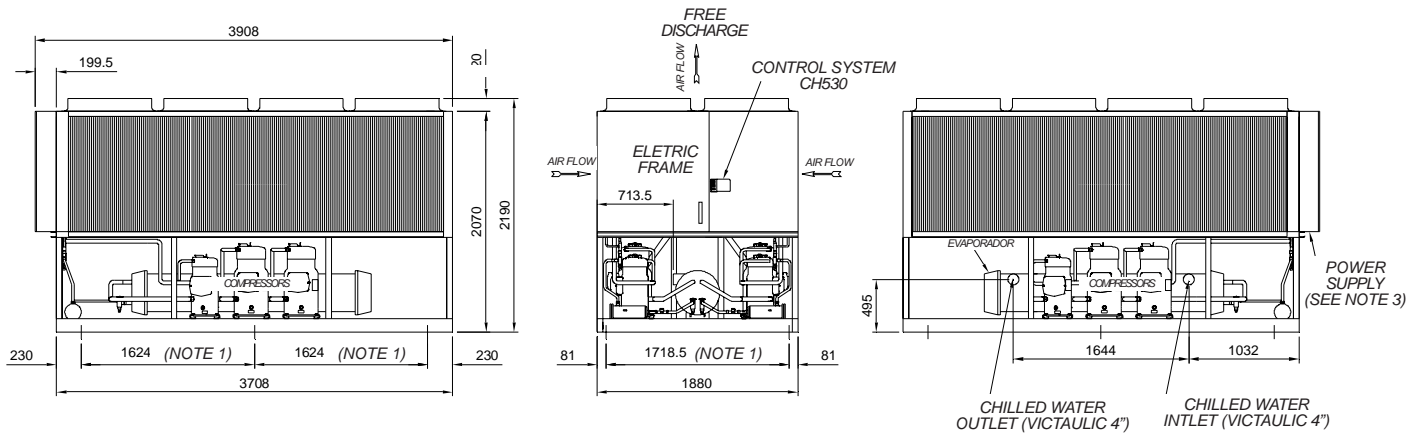

- NOTES:
- 1 - FIXING POINTS FOR VIBRATION INSULATORS (6mm DIAM HOLES)
 - 2 - VIBRATION INSULATORS ARE NOT SUPPLIED WITH THE EQUIPMENT.
 - 3 - THE ORIFICE FOR ENTRY OF ELECTRICAL CABLES BE CARRIED OUT IN THE FIELD BY THE INSTALLER.
 - 4 - UNITS : mm

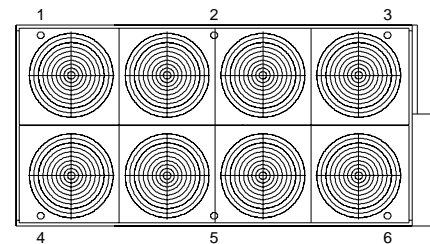
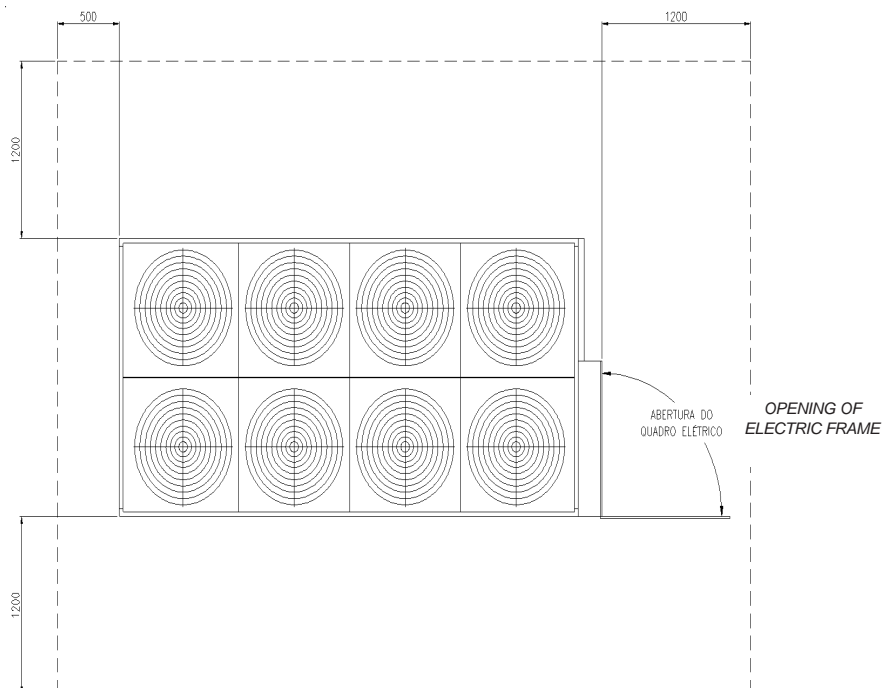

Fig. 24 - Maintenance and air circulation clearances



Dimensional Data

CGAD 090

Fig. 25 - Unit Dimensions - CGAD 090

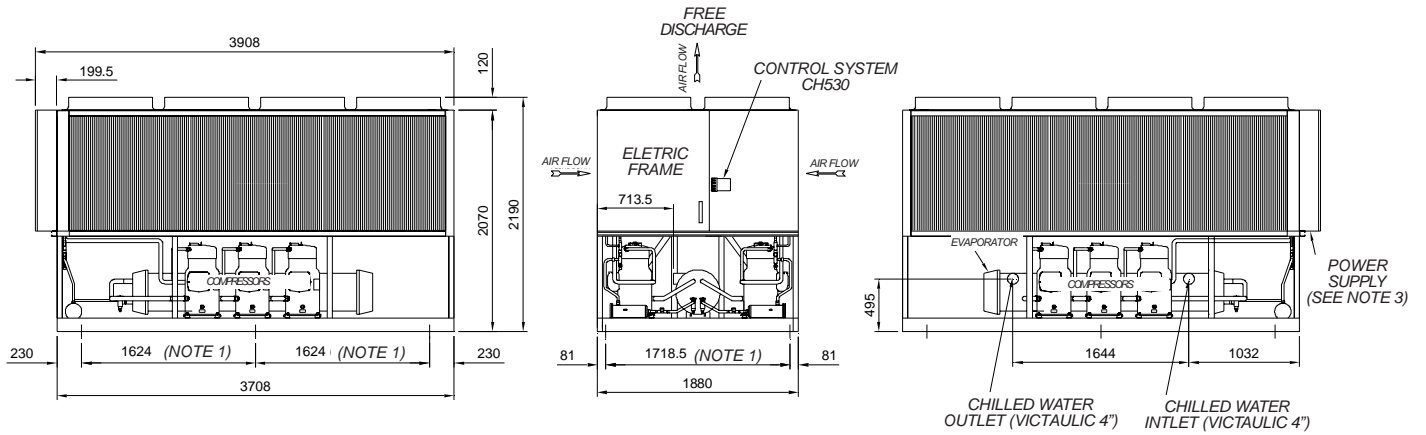

- NOTES:
- 1 - FIXING POINTS FOR VIBRATION INSULATORS (6 X 13mm DIAM HOLES)
 - 2 - VIBRATION INSULATORS ARE NOT SUPPLIED WITH THE EQUIPMENT.
 - 3 - THE ORIFICE FOR ENTRY OF ELECTRICAL CABLES SHOULD BE CARRIED OUT IN THE FIELD BY THE INSTALLER.
 - 4 - UNITS : mm

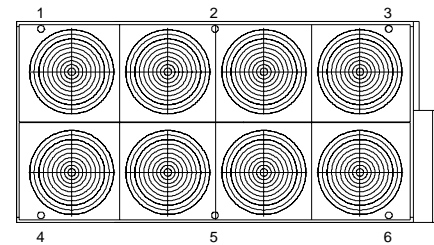
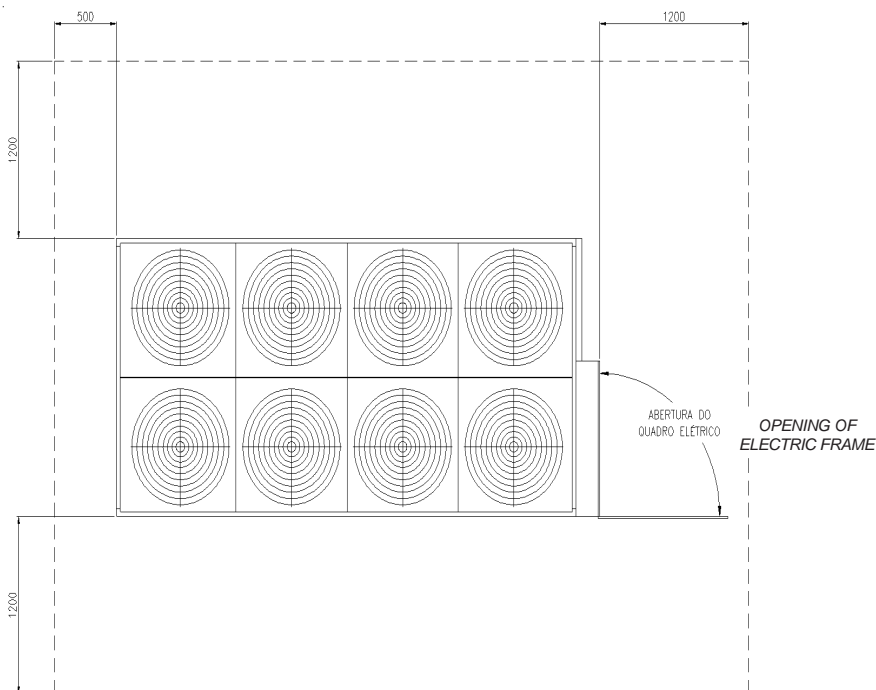

Fig. 26 - Maintenance and air circulation clearances



Dimensional Data

CGAD 100

Fig. 27 - Unit Dimensions - CGAD 100

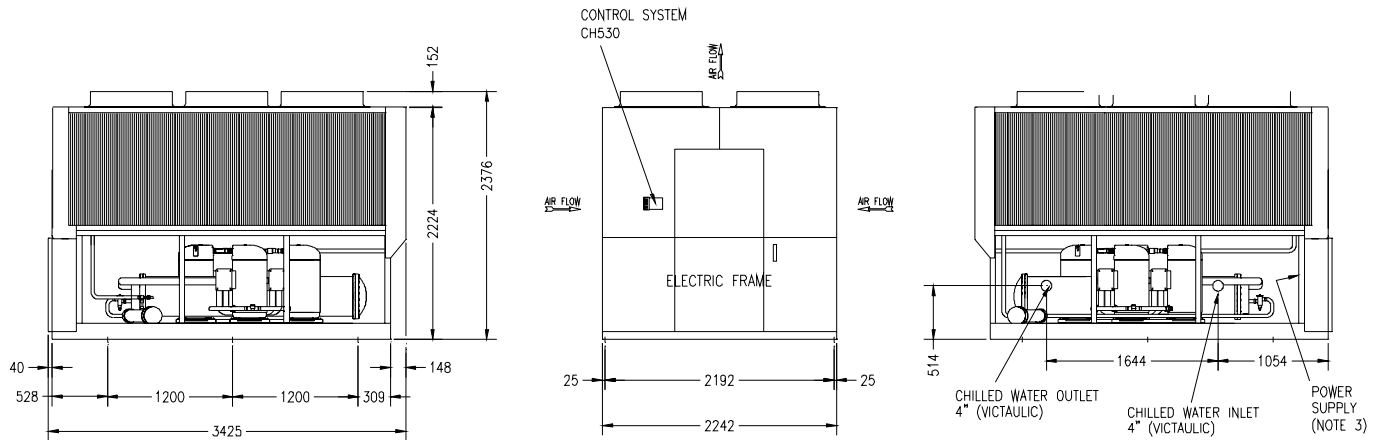

- NOTES:
- 1 - FIXING POINTS FOR VIBRATION INSULATORS (6 X. 17,5 mm DIAM HOLES)
 - 2 - VIBRATION INSULATORS ARE NOT SUPPLIED WITH THE EQUIPMENT.
 - 3 - THE ORIFICE FOR ENTRY OF ELECTRICAL CABLES SHOULD BE CARRIED OUT IN THE FIELD BY THE INSTALLER.
 - 4 - UNITS : mm

Fig. 28 - Maintenance and air circulation clearances

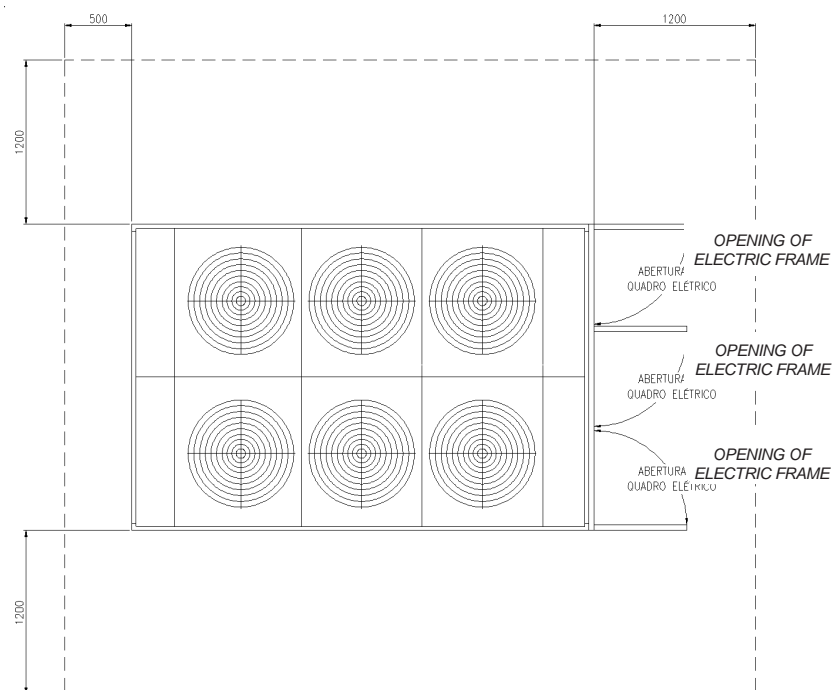

Dimensional Data

CGAD 120

Fig. 29 - Unit Dimensions - CGAD 120

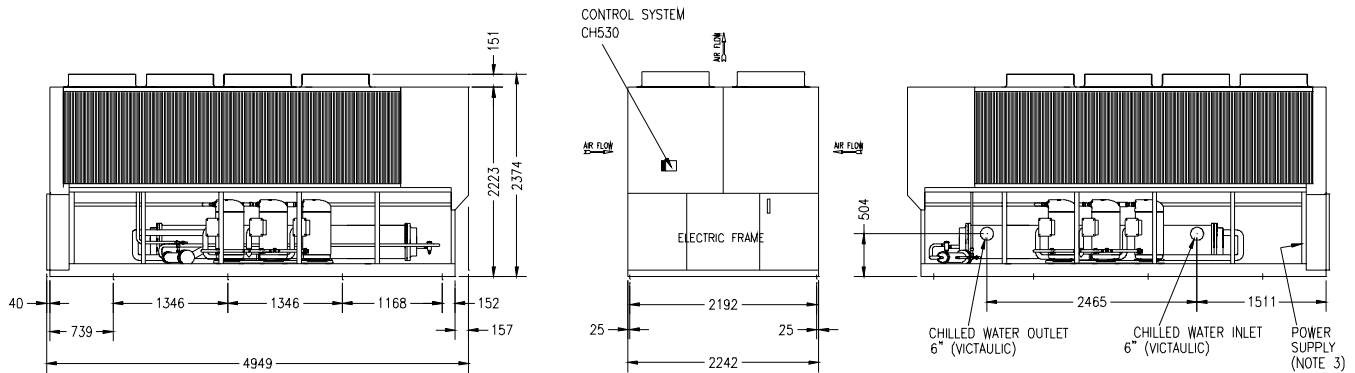

- NOTES:
- 1 - FIXING POINTS FOR VIBRATION INSULATORS (8 X1 7,5mm DIAM HOLES)
 - 2 - VIBRATION INSULATORS ARE NOT SUPPLIED WITH THE EQUIPMENT.
 - 3 - THE ORIFICE FOR ENTRY OF ELECTRICAL CABLES SHOULD BE CARRIED OUT IN THE FIELD BY THE INSTALLER.
 - 4 - UNITS : mm

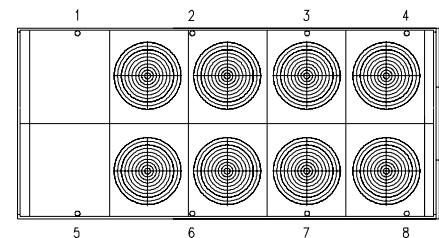
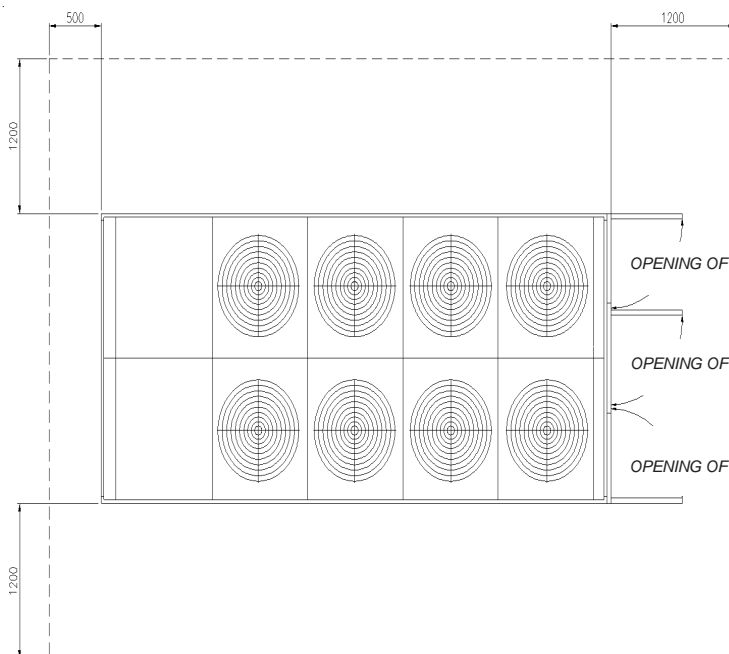

Fig. 30 - Maintenance and air circulation clearances



Dimensional Data

CGAD 150

Fig. 31 - Unit Dimensions - CGAD 150

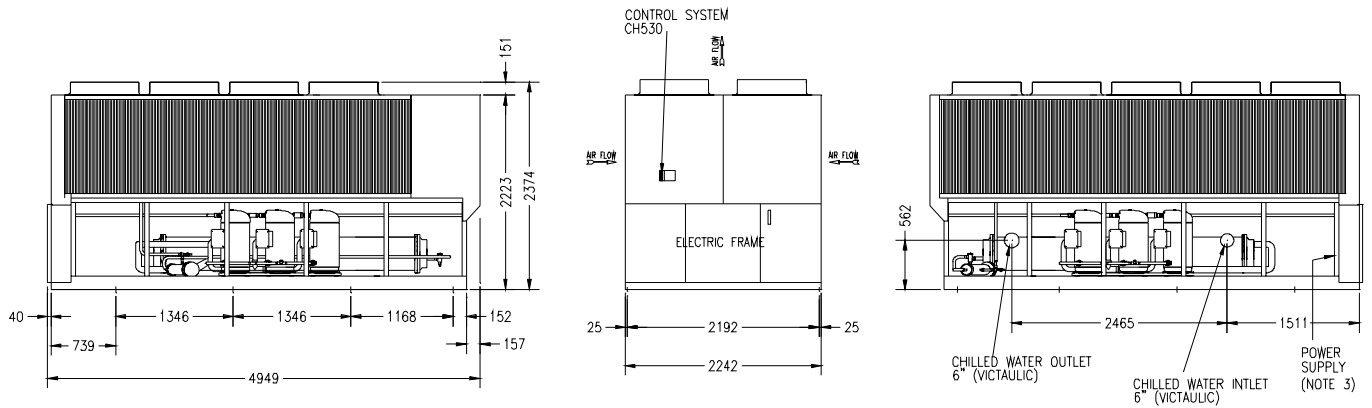

- NOTES:
- 1 - FIXING POINTS FOR VIBRATION INSULATORS (8 X 17,5mm DIAM HOLES)
 - 2 - VIBRATION INSULATORS ARE NOT SUPPLIED WITH THE EQUIPMENT.
 - 3 - THE ORIFICE FOR ENTRY OF ELECTRICAL CABLES SHOULD BE CARRIED OUT IN THE FIELD BY THE INSTALLER.
 - 4 - UNITS : mm

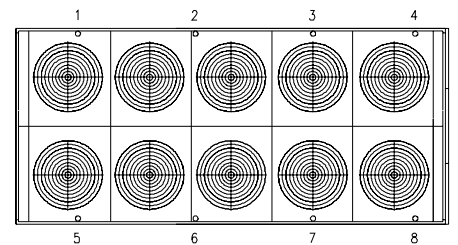
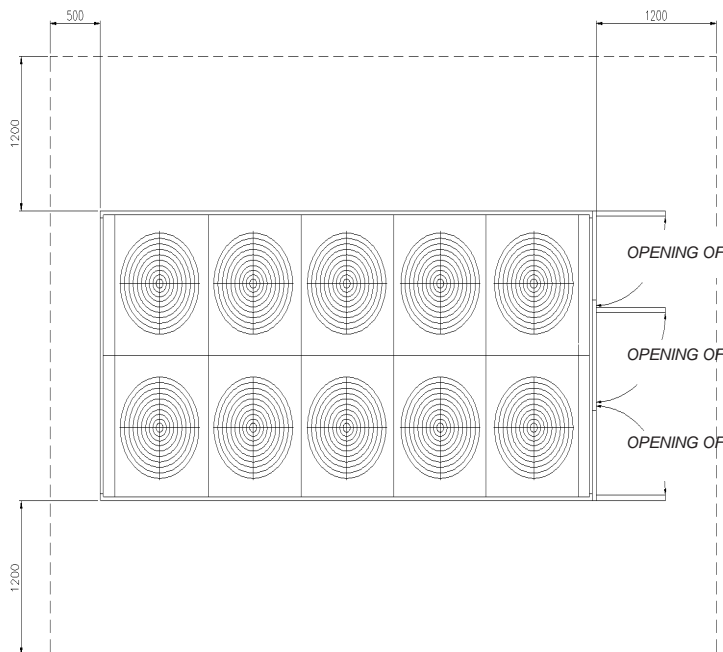

Fig. 32 - Maintenance and air circulation clearances



Mechanical Specifications

Evaporators

Shell & Tube evaporators are designed according to the ASME standard for pressure vessels, without internal combustion, and are factory tested with 225 psig at refrigerant side (tubes) and 150 psig at water side (casing). The evaporator casing is made of carbon steel and the covers are made of cast iron.

The copper tubes are internally-rifled, seamless tubes, mounted and mechanically expanded in carbon steel mirrors to avoid refrigerant leaks. In order to avoid tube vibration problems and maintain the crossed drainage of evaporator water, traverse baffle plates are mounted along the evaporator. Thermal insulation of the assembly is provided by 16-mm rubber sheets.

Refrigerating lines

Trane CGAD Air-Cooled Liquid Chillers are equipped with the following refrigerating lines:

Model	Suction	Discharge	Liquid
020	1 5/8"	1 3/8"	7/8"
025	2 1/8"	1 3/8"	7/8"
030	2 1/8"	1 3/8"	7/8"
040	2 x 1 5/8"	2 x 1 3/8"	2 x 7/8"
050	2 x 2 5/8"	2 x 1 3/8"	2 x 7/8"
060	2 x 2 5/8"	2 x 1 3/8"	2 x 7/8"
070	2 x 2 5/8"	2 x 1 3/8"	2 x 1 1/8"
080	2 x 2 5/8"	2 x 1 3/8"	2 x 1 1/8"
090	2 x 2 5/8"	2 x 1 3/8"	2 x 1 1/8"
100	2 5/8"	1 5/8"	1 1/8"
120	3 1/8"	1 5/8"	1 1/8"
150	3 1/8"	1 5/8"	1 1/8"

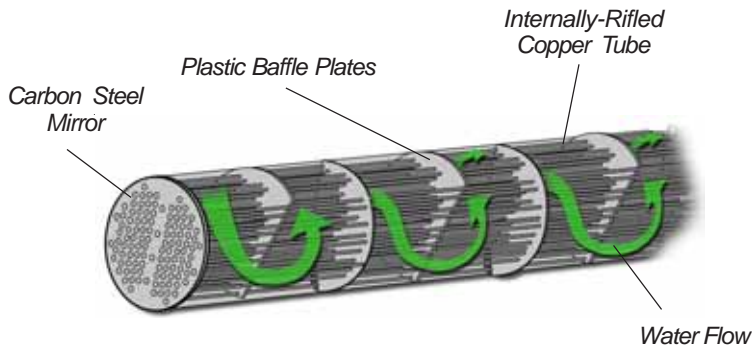

Fig. 33 - Shell & Tube Evaporator

Condensers

Coil-type condensers are built with aluminum fins model Wavy-3B, 3/8"-OD internally-rifled copper tubes, mechanically expanded in the fins, and galvanized steel structure, and are equipped with an integral sub-cooler. After manufacturing, condensers are tested with a pressure of 30 kgf/cm² (425 psig).30 kgf/cm² (425 psig).

Global Connector

The Global Connectors facilitate the connection of terminals and decrease the interference.

They have aesthetically pleasing; automotive industry grade; sealed connector system; easier connection for factory and field; repeated manual disconnection and re-connection allowed.

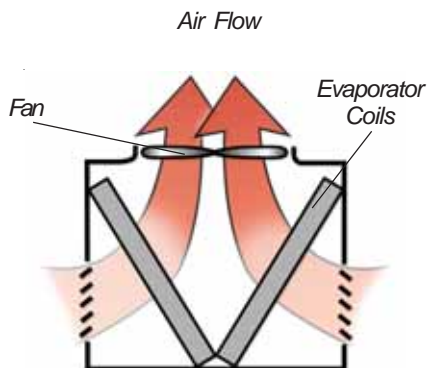

Fig. 34 - Condenser Air Flow



Fig. 35 - Global Connector

Mechanical Specifications

Cooling Components

Trane 20, 25 and 30Tons CGAD Air-Cooled Liquid Chillers have only one cooling circuit, and the 40, 50, 60, 70, 80 and 90 Tons units have two independent cooling circuits. Each cooling circuit is supplied with the following components:

- Thermostatic expansion valve;
- Tank valve at condenser outlet, with a pressure intake point of 1/4" SAE;
- Liquid sightglass with humidity indicator;
- Dryer filter;



Fig. 36 - Liquid Sightglass



Fig. 37 - Expansion Valve

Compressor Scroll

Compressors Scroll provide more benefits to the air conditioning system user when compared to reciprocating compressors.

- They have a 5 to 10% higher efficiency, in average;
- They do have no valves, being extremely resistant to slugging;
- They have 64% fewer moving parts;
- Extremely smooth and silent operation, comparable to a centrifugal compressor;
- Low torque variation, which provides vibration and noise reduction and increases motor life.

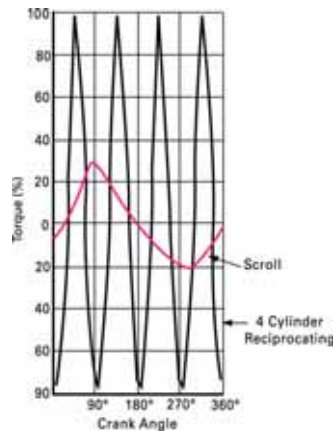

Fig. 38 - Comparison Scroll x Reciprocating

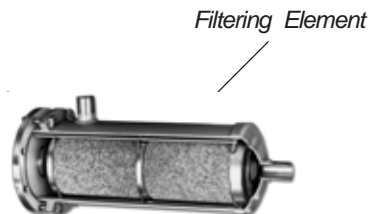

Fig. 39 - Drier Filter

Compression Cycle

Figure above shows a Scroll compressor in detail, presenting its main components and the operational principle, according to the items below:

- A.** The refrigerant, in gaseous state, is suctioned into its interior through the suction connection.
- B.** The refrigerant passes through a cavity between the rotor and the stator, cooling the motor.
- C.** The refrigerant speed decreases when it leaves the motor cavity and the oil is separated. The oil returns to the crankcase.
- D.** The refrigerant goes into the suction chamber and fills out the compression scroll.
- E.** After compression, the refrigerant is discharged in the compressor hood through a hole in the center of the fixed Scroll. The hood function is to amortize the refrigerant flow, reducing vibrations. Then the refrigerant leaves the compressor through the discharge connection.

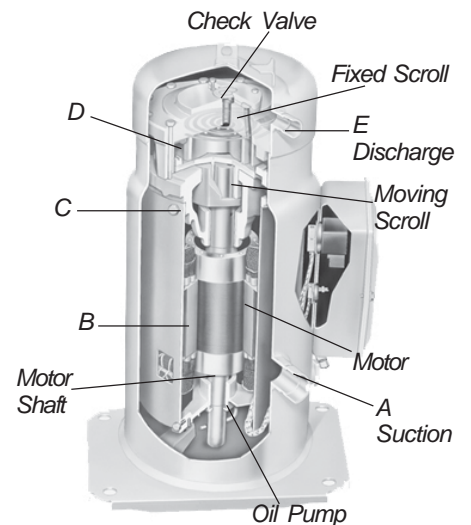

Fig. 40 - Compressor Scroll

General Dimensions

Tab.10 - General dimensional data

Modelo	Height	Width ⁽¹⁾	Depth	Floor Area ⁽²⁾	Operational Weight	Shipping Weight
	mm	mm	mm	m ²	kg	kg
CGAD020C	1840,5	2195,0	1350,0	2,700	1340	1300
CGAD025C	1840,5	2195,0	1700,0	3,400	1420	1380
CGAD030C	1840,5	2195,0	1700,0	3,400	1480	1420
CGAD040C	2190,5	2389,0	1880,0	3,940	1910	1860
CGAD050C	2190,5	2989,0	1880,0	5,250	2210	2130
CGAD060C	2190,5	2989,0	1880,0	5,250	2500	2360
CGAD070C	2190,5	3695,0	1880,0	6,580	3000	2850
CGAD080C	2190,5	3903,0	1880,0	6,970	3240	3100
CGAD090C	2190,5	3903,0	1880,0	6,970	3220	3100
CGAD100C	2376,0	3425,0	2442,0	7,237	3775	3653
CGAD120C	2376,0	4949,0	2442,0	10,654	4135	3962
CGAD1500C	2376,0	4949,0	2442,0	10,654	4653	4376

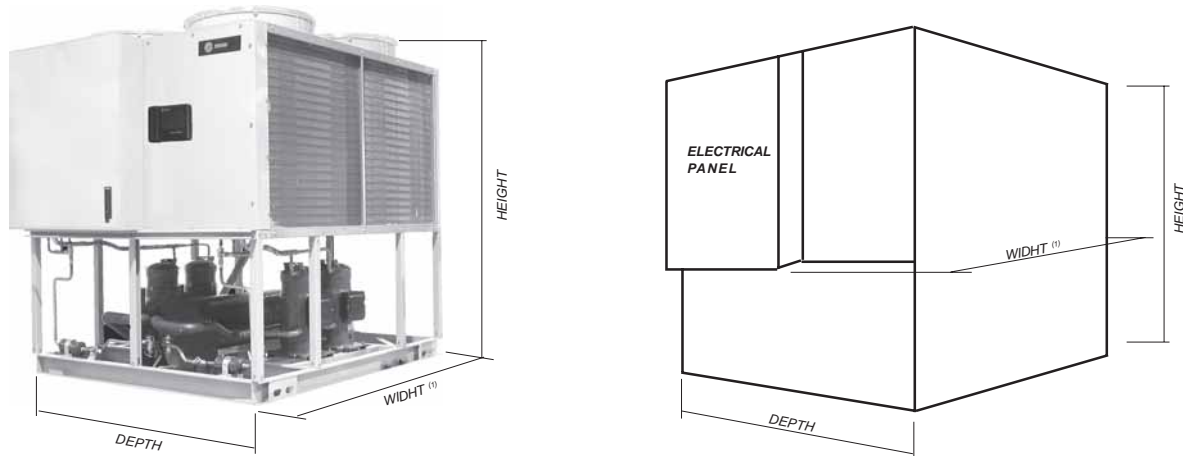

Fig. 41 -- Dimensional drawing

Notas:

(1) The length measurements take into account the depth of the electrical frame coupled to the equipment.

(2) The floor area measurements do not take into account the base of the electrical frame coupled to the equipment.



Conversion Table

To convert from:	To:	Multiply By:	To convert from:	To:	Multiply By:
Length			Velocity		
Feet (ft)	meters (m)	0,30481	Feet per minute (ft/min)	meters per second (m/s)	0,00508
Inche (in)	milimeters (mm)	25,4	Feet per second (ft/s)	meters per second (m/s)	0,3048
Area			Energy, Power and Capacity		
Square feet (ft ²)	square meters(m ²)	0,93	British Termal Units (BTU)	Kilowatt (kW)	0,000293
Square inche(in ²)	square milimeters(mm ²)	645,2	British Termal Units (BTU)	Kilocalorie (kcal)	0,252
			Tons (refrig. Effect)	Kilowatt (kW)	3,516
Volume			Tons (refrig. Effect)	Kilocalorie per hour (kcal/h)	3024
Cubic feet (ft ³)	cubic meters(m ³)	0,0283	Horsepower (HP)	Kilowatt (kW)	0,7457
Cubic Inches (in ³)	cubic milimeters (mm ³)	16387			
Gallons (gal)	litres (L)	3,785			
Gallons (gal)	cubic meters (m ³)	0,003785	Pressão		
Flow			Feet of water (ft.H ₂ O)	Pascal (Pa)	2990
Cubic feet / min (cfm)	cubic meters / second (m ³ /s)	0,000472	Inches os water (in.H ₂ O)	Pascal (Pa)	249
Cubic feet / min (cfm)	cubic meters / hour (m ³ /h)	1,69884	Pounds per square inch (PSI)	Pascal (Pa)	6895
Gallons / min (GPM)	cubic meters / hour (m ³ /h)	0,2271	Pounds per square inch (PSI)	Bar ou kg/cm ²	6,895 x 10 ⁻⁴
Gallons / min (GPM)	litres / second (L/s)	0,06308			
			Peso		
			Ounces (oz)	Kilograms (kg)	0,02835
			Pounds (lbs)	Kilograms (kg)	0,4536

Temperature		
°C	Cou F	°F
-40,0	-40	-40
-39,4	-39	-38,2
-38,9	-38	-36,4
-38,3	-37	-34,6
-37,8	-36	-32,8
-37,2	-35	-31
-36,7	-34	-29,2
-36,1	-33	-27,4
-35,6	-32	-25,6
-35,0	-31	-23,8
-34,4	-30	-22
-33,9	-29	-20,2
-33,3	-28	-18,4
-32,8	-27	-16,6
-32,2	-26	-14,8
-31,7	-25	-13
-31,1	-24	-11,2
-30,6	-23	-9,4
-30,0	-22	-7,6
-29,4	-21	-5,8
-28,9	-20	-4
-28,3	-19	-2,2
-27,8	-18	-0,4
-27,2	-17	1,4
-26,7	-16	3,2
-26,1	-15	5
-25,6	-14	6,8
-25,0	-13	8,6
-24,4	-12	10,4
-23,9	-11	12,2
-23,3	-10	14
-22,8	-9	15,8
-22,2	-8	17,6
-21,7	-7	19,4
-21,1	-6	21,2
-20,6	-5	23
-20,0	-4	24,8
-19,4	-3	26,6
-18,9	-2	28,4
-18,3	-1	30,2
-17,8	0	32
-17,2	1	33,8
-16,7	2	35,6
-16,1	3	37,4
-15,6	4	39,2

Temperature		
°C	Cou F	°F
-15,0	5	41
-14,4	6	42,8
-13,9	7	44,6
-13,3	8	46,4
-12,8	9	48,2
-12,2	10	50
-11,7	11	51,8
-11,1	12	53,6
-10,6	13	55,4
-10,0	14	57,2
-9,4	15	59
-8,9	16	60,8
-8,3	17	62,6
-7,8	18	64,4
-7,2	19	66,2
-6,7	20	68
-6,1	21	69,8
-5,6	22	71,6
-5,0	23	73,4
-4,4	24	75,2
-3,9	25	77
-3,3	26	78,8
-2,8	27	80,6
-2,2	28	82,4
-1,7	29	84,2
-1,1	30	86
-0,6	31	87,8
0,0	32	89,6
0,6	33	91,4
1,1	34	93,2
1,7	35	95
2,2	36	96,8
2,8	37	98,6
3,3	38	100,4
3,9	39	102,2
4,4	40	104
5,0	41	105,8
5,6	42	107,6
6,1	43	109,4
6,7	44	111,2
7,2	45	113
7,8	46	114,8
8,3	47	116,6
8,9	48	118,4
9,4	49	120,2

Temperature		
°C	Cou F	°F
10,0	50	122
10,6	51	123,8
11,1	52	125,6
11,7	53	127,4
12,2	54	129,2
12,8	55	131
13,3	56	132,8
13,9	57	134,6
14,4	58	136,4
15,0	59	138,2
15,6	60	140
16,1	61	141,8
16,7	62	143,6
17,2	63	145,4
17,8	64	147,2
18,3	65	149
18,9	66	150,8
19,4	67	152,6
20,0	68	154,4
20,6	69	156,2
21,1	70	158
21,7	71	159,8
22,2	72	161,6
22,8	73	163,4
23,3	74	165,2
23,9	75	167
24,4	76	168,8
25,0	77	170,6
25,6	78	172,4
26,1	79	174,2
26,7	80	176
27,2	81	177,8
27,8	82	179,6
28,3	83	181,4
28,9	84	183,2
29,4	85	185
30,0	86	186,8
30,6	87	188,6
31,1	88	190,4
31,7	89	192,2
32,2	90	194
32,8	91	195,8
33,3	92	197,6
33,9	93	199,4
34,4	94	201,2

Temperature		
°C	Cou F	°F
35,0	95	203
35,6	96	204,8
36,1	97	206,6
36,7	98	208,4
37,2	99	210,2
37,8	100	212
38,3	101	213,8
38,9	102	215,6
39,4	103	217,4
40,0	104	219,2
40,6	105	221
41,1	106	222,8
41,7	107	224,6
42,2	108	226,4
42,8	109	228,2
43,3	110	230
43,9	111	231,8
44,4	112	233,6
45,0	113	235,4
45,6	114	237,2
46,1	115	239
46,7	116	240,8
47,2	117	242,6
47,8	118	244,4
48,3	119	246,2
48,9	120	248
49,4	121	249,8
50,0	122	251,6
50,6	123	253,4
51,1	124	255,2
51,7	125	257
52,2	126	258,8
52,8	127	260,6
53,3	128	262,4
53,9	129	264,2
54,4	130	266
55,0	131	267,8
55,6	132	269,6
56,1	133	271,4
56,7	134	273,2
57,2	135	275
57,8	136	276,8
58,3	137	278,6
58,9	138	280,4
59,4	139	282,2

Temperature		
°C	Cou F	°F
60,0	140	284
60,6	141	285,8
61,1	142	287,6
61,7	143	289,4
62,2	144	291,2
62,8	145	293
63,3	146	294,8
63,9	147	296,6
64,4	148	298,4
65,0	149	300,2
65,6	150	302
66,1	151	303,8
66,7	152	305,6
67,2	153	307,4
67,8	154	309,2
68,3	155	311
68,9	156	312,8
69,4	157	314,6
70,0	158	316,4
70,6	159	318,2
71,1	160	320
71,7	161	321,8
72,2	162	323,6
72,8	163	325,4
73,3	164	327,2
73,9	165	329
74,4	166	330,8
75,0	167	332,6
75,6	168	334,4
76,1	169	336,2
76,7	170	338
77,2	171	339,8
77,8	172	341,6
78,3	173	343,4
78,9	174	345,2
79,4	175	347
80,0	176	348,8
80,6	177	350,6
81,1	178	352,4
81,7	179	354,2
82,2	180	356
82,8	181	357,8
83,3	182	359,6
83,9	183	361,4
84,4	184	363,2



Trane optimizes the performance of homes and buildings around the world. A business of Ingersoll Rand, the leader in creating and sustaining safe, comfortable and energy efficient environments, Trane offers a broad portfolio of advanced controls and HVAC systems, comprehensive building services, and parts. For more information, visit www.trane.com.br

Trane has a policy of continuous product and product data improvement and reserves the right to change design and specifications without notice.

© 2012 Trane
All rights reserved
CG-PRC002E-EN July 2012
Supersedes CG-PRC002D-EN September 2009

Produced with paper that uses fewer
trees and chemicals, less energy, and
environmentally friendly print practices that
reduce waste.

