



Product Catalog

# Split System

Air-Cooled Condensers — 20 to 120 Tons





## Introduction

**Trane has the right condenser...** If you are designing a new system or replacing an existing air-cooled condenser, Trane can satisfy virtually any application need. Whether coupled with an industrial compressor, a single zone commercial self-contained unit, compressor chiller or a Cold Generator™ chiller, Trane has the right air-cooled condenser for the job. When teamed with any one of a wide range of compressor-evaporator combinations, Trane air-cooled condensers, available in 20 to 120 tons, are ideal for multistory office buildings, hotels, schools, municipal and industrial facilities, and more.



## Copyright

This document and the information in it are the property of Trane, and may not be used or reproduced in whole or in part without written permission. Trane reserves the right to revise this publication at any time, and to make changes to its content without obligation to notify any person of such revision or change.

## Trademarks

All trademarks referenced in this document are the trademarks of their respective owners.

## Revision History

- Miscellaneous edits in Introduction and Unit Dimensions section.
- Revised Corrosion Protected Condenser Coil in Mechanical Specification section.



# Table of Contents

Features and Benefits.....	4
20 to 120 Ton Units .....	4
Durable Construction .....	4
Microchannel Condenser Coil.....	4
Application Considerations .....	5
Unit Location .....	5
Voltage .....	6
Effect of Altitude on Capacity .....	6
Ambient Considerations.....	6
Corrosive Atmospheres .....	6
Selection Procedures .....	8
Model Number Description .....	11
General Data.....	12
Performance Data .....	13
Performance Adjustment Factors.....	13
Performance Data.....	14
Electrical.....	15
Unit Dimensions.....	16
Unit Weights.....	30
Mechanical Specifications .....	31
Air-Cooled Condenser – Model CAUJ.....	31
Options .....	31



# Features and Benefits

## 20 to 120 Ton Units

Trane® 20 to 120 ton model CAUJ air-cooled condensers have an operating range of 40°F to 115° F, with a low ambient option down to 0°F.

The control panel is factory-installed and wired to prevent potential damage and to provide weathertight protection.

The control panel contains:

- fan motor contactors
- fan cycling controls
- terminal point connection for compressor interlock
- 115-volt control power transformer

These standard features reduce installation costs and provide easy interface with control logic.

All Trane air-cooled condenser coils are an all aluminum microchannel design. The 20 to 30 ton condensers are single circuit; 40 to 120 ton units are dual circuited; all feature integral subcooling.

Units can have optional corrosion protected condenser coil.

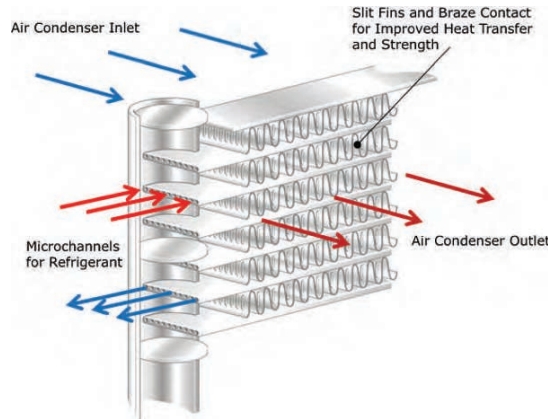
## Durable Construction

Trane® 20 to 120 ton condensers are built for long life. The unit frame is constructed of 14 gauge galvanized steel. Louvered panels provide excellent coil protection while enhancing unit appearance and strength. The unit surface is phosphatized and finished with Trane slate grey air-dry paint. This air dry-paint finish exceeds 672 consecutive hour salt spray resistance in accordance with ASTM B117.

## Microchannel Condenser Coil

Microchannel condensing coils are all-aluminum coils with fully-brazed construction. This design reduces risk of leaks and provides increased coil rigidity — making them more rugged on the jobsite. Their flat streamlined tubes with small ports and metallurgical tube-to-fin bond allow for exceptional heat transfer. Microchannel all-aluminum construction provides several additional benefits:

- Light weight (simplifies coil handling)
- Easy to recycle
- Minimize galvanic corrosion





# Application Considerations

Certain application constraints should be considered when sizing, selecting and installing Trane® air-cooled condensers. Unit reliability is dependent upon these considerations. Where your application varies from the guidelines presented, it should be reviewed with the local Trane sales engineer.

## Unit Location

### Foundation

A base or foundation is not required if the selected unit location is level and strong enough to support the unit's operating weight.

### Isolation and Sound Emission

Since the environment in which a sound source is located affects sound pressure, unit placement must be carefully evaluated. The most effective form of noise isolation is proper unit location. Units should be placed away from noise sensitive areas.

Structurally transmitted sound can be reduced by using isolators, which are recommended for sound sensitive installations. For maximum isolation effect, the refrigeration lines and electrical conduit should also be isolated and flexible electrical conduit used.

An acoustical engineer should always be consulted on critical applications.

State and local codes on sound emissions should always be considered.

### Air Flow Considerations

Unobstructed flow of condenser air is essential for maintaining capacity and operating efficiency. When determining unit placement, careful consideration must be given to assure proper air flow across the condenser heat transfer surface. Inadequate air flow will result in warm air recirculation and coil air flow starvation.

- Warm air recirculation occurs when discharge air from the condenser fans is recycled back at the condenser coil inlet.
- Coil starvation occurs when free air flow to the condenser is restricted.

Both warm air recirculation and coil starvation cause reductions in unit efficiency and capacity. In more severe cases, nuisance unit shutdowns will result from excessive head pressures. Accurate estimates of the degree of efficiency and capacity reduction are not possible due to the unpredictable effect of varying winds.

When hot gas bypass is used, reduced head pressure increases the minimum ambient condition for proper operation. In addition, wind tends to further reduce head pressure. Therefore, it is advisable to protect the air-cooled condensing unit from continuous direct winds exceeding 10 miles per hour.

Debris, trash, supplies, etc., should not be allowed to accumulate in the vicinity of the air-cooled condenser. Supply air movement may draw debris between coil fins and cause coil starvation. Special consideration should be given to units operating in low ambient temperatures. Condenser coils and fan discharge must be kept free of snow and other obstructions to permit adequate air flow for satisfactory unit operation.

### Clearances

Adequate service clearance is required for unit access and maintenance. See Dimensions chapter for service clearance recommendations. Local code requirements may take precedence.

Vertical condenser air discharge must be unobstructed. While it is difficult to predict the degree of warm air recirculation, a unit installed with a ceiling or other obstruction above it will lose capacity and the maximum ambient operation will be reduced. Nuisance high head pressure trips may also occur.

The inlet to the coil must also be unobstructed. A unit installed closer than the minimum recommended distance to a wall or other vertical riser may experience a combination of coil



## Application Considerations

starvation and warm air recirculation, resulting in unit capacity and efficiency reductions, as well as possible excessive head pressures. The recommended lateral distances are listed in the Dimensional Data section.

## Voltage

Nominal voltage is the nameplate rating voltage. The actual range of line voltages at which the equipment can satisfactorily operate is given below:

**Table 1. Voltage range**

Nominal Voltage	Voltage Utilization Range
200/230 <sup>(a)</sup>	180-220 or 208-254
460	416-508
575	520-635

<sup>(a)</sup> Units rated for 200/230-volts ship from the factory set for operation in the 180 through 220-volt range. By changing leads on unit transformers, the unit will operate in the 208 through 254-volt range.

## Effect of Altitude on Capacity

Capacities given in the performance data tables are at sea level. At elevations substantially above sea level, the decreased air density will decrease condenser capacity. The adjustment factors shown in can be applied directly to the catalog performance data to determine the unit's adjusted performance.

## Ambient Considerations

Trane condensers are designed for year-around applications in ambients from 0°F through 115°F. For operation below 0°F or above 115°F, contact the local Trane sales office.

Start-up and operation at lower ambients requires sufficient head pressure be maintained for proper operation. Minimum operating ambient temperatures for standard unit selections and units with hot gas bypass are shown in the General Data section. These temperatures are based on still conditions (winds not exceeding five mph.) Greater wind velocities will result in a drop in head pressure, therefore, increasing the minimum starting and operating ambient temperatures.

Units with the low ambient option are capable of starting and operating in ambients down to 0°F, 10°F with hot gas bypass. Optional low ambient units use a condenser fan damper arrangement that controls condenser capacity by modulating in response to head pressure.

Maximum cataloged ambient temperature operation of a standard condenser is 115°F. Operation at design ambients above 115°F can result in excessive head pressures.

For proper operation outside these recommendations, contact the local Trane sales office.

## Corrosive Atmospheres

Trane's large condensers are designed and built to industrial standards and will perform to those standards for an extended period depending on the hours of use, the quality of maintenance performed, and the regularity of that maintenance. One factor that can have an adverse effect on unit life is its operation in a corrosive environment. Since the microchannel condenser coil is an all-aluminum design, it provides a high level of corrosion protection on its own. Uncoated, it withstands a salt spray test in accordance with ASTM B117 for 1,000 hours. When condensers are operated in highly corrosive environments, Trane recommends the corrosion protected condenser coil option. This corrosion protection option meets the most stringent testing in the industry, including ASTM B117 Salt Spray test for 6,000 hours and ASTM G85A2 Cyclic Acidified Salt Fog test for 2,400 hours. The acid fog test is the most stringent available today. This coating is added after coil construction covering all tubes, headers, fins and edges. The design provides superior protection from any corrosive agent.

**Note:** Field coating is not allowed on microchannel coils.

The exterior panels are durable enough to withstand a minimum of 672 hours consecutive salt spray application in accordance with standard ASTM B117. All screws are coated with zinc-plus-zinc chromate.



# Selection Procedures

When manually matching condensers with compressors, performance cross plotting becomes necessary. The following procedure should be used to determine the correct condenser.

1. Determine the total cooling load. Make a preliminary compressor selection based on the expected evaporator SST and condensing temperature.

**Example**

Given: Total cooling load = 101 tons (1212 Mbh) Design outdoor temperature = 95°F

Assume: Evaporator SST = 45°F (used in this example - application dependent) Condenser SCT between 115°F and 125°F (20-30°F ITD SCT-ambient)

2. Select compressors from manufacturer's data to meet the load at the evaporator SST (for chiller low suction applications contact Trane applications).

**Table 2. Compressor capacity with subcooling**

<b>(Qty 2) CSHN611 Trane R-410A Trio Scrolls Performance data includes 15°F subcooling</b>			
<b>SST</b>	<b>SCT</b>	<b>Tons</b>	<b>Mbh</b>
45	115	110	1320
45	125	103	1236

**Notes:**

1. SST = Saturated Suction Temperature
2. SCT = Saturated Condensing Temperature

3. Remove the subcooling effect from the compressor performance at two or more compressor capacity points.
  - a. R-410A capacity increases 0.75% for every degree of subcooling ( $0.75\% \times 15^\circ\text{F} = 11.25\%$ ).
  - b. If compressor performance is at 15°F subcooling, divide capacity by 1.1125 to get capacity at 0°F subcooling.
  - c. Plot these two points (SCT vs. compressor tons a 0°F subcooling) as shown in the selection example. See "Figure 1," p. 9.



Figure 1. Selection example

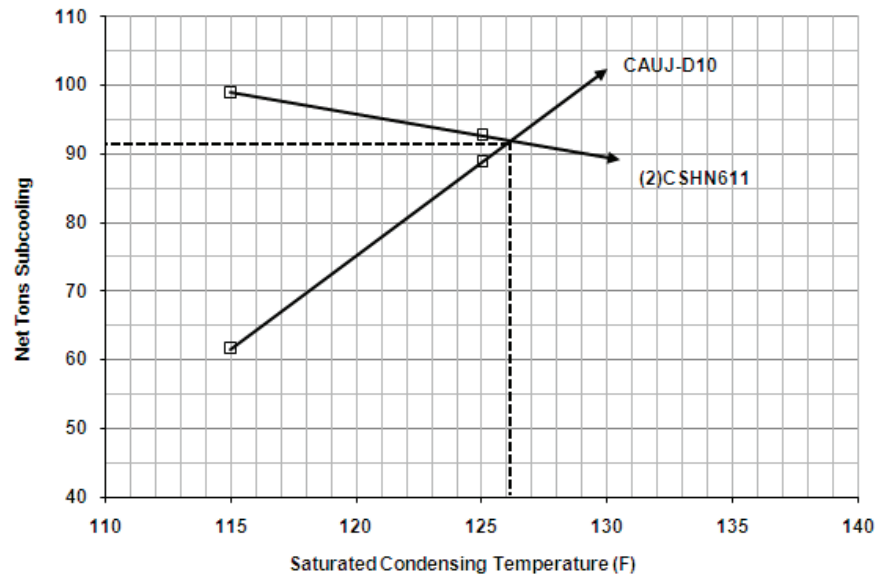


Table 3. Compressor capacity with subcooling removed

SST <sup>(a)</sup>	SCT <sup>(b)</sup>	(Qty 2) CSHN611 Trane R-410A Trio Scrolls			
		Capacity			
		15°F subcooling		0°F subcooling	
		Tons	Mbh	Tons	Mbh
45	115	110	1320	98.9	1187
45	125	103	1236	92.6	1111

<sup>(a)</sup> SST = Saturated Suction Temperature

<sup>(b)</sup> SCT = Saturated Condensing Temperature

4. Select a condenser on the Condenser Heat Rejection graph in Performance Data chapter and read two condenser-only heat rejection points.
5. Divide the condenser heat rejection by the compressor N factor found in Table 4, p. 9 to convert from heat rejection to net capacity (Net Tons Less Subcooling).

**Note:** The N factor equals the ratio of compressor heat rejection divided by compressor capacity at 0°F subcooling.

Table 4. N factor - Trane R-410A scroll compressors

Sat cond temp °F	Saturated suction temperature, °F				
	30	35	40	45	50
110	1.33	1.30	1.27	1.24	1.22
115	1.36	1.33	1.30	1.27	1.25
120	1.40	1.36	1.33	1.30	1.27
125	1.45	1.40	1.37	1.33	1.30
130	1.50	1.45	1.41	1.37	1.34
135	1.57	1.51	1.46	1.41	1.37
140	1.64	1.57	1.51	1.46	1.42
145	1.73	1.65	1.58	1.53	1.48

6. Plot these two points (SCT vs. Net Tons at 0°F subcooling) as shown in [Figure 1, p. 9](#) selection example.

**Table 5. Condenser net capacity Mbh (less subcooling)**

Assumed ΔT°F ITD (SCT - ambient)	Ambi- ent °F	SCT °F	Cond only heat rejection Mbh	N factor	Net capacity less subcooling	
					Mbh	Tons
20	95	115	938	1.27	739	61.5
30	95	125	1418	1.33	1066	88.8

**Notes:**

1. ITD = Initial Temperature Difference
2. SCT = Saturated Condensing Temperature
3. N Factor = Compressor Efficiency Ratio

7. As shown on "[Figure 1,](#)" p. 9, draw a line through the points representing the compressor capacity at 0°F subcooling.
8. Draw a line through the points representing condenser net capacity less subcooling.
9. At the point of intersection of the compressor and condenser lines, draw dashed lines to the left and bottom margins as shown in [Figure 1, p. 9](#). The end points of these lines will show a resultant gross capacity of 92 tons at 126.1°F condensing temperature.
10. From the condenser heat rejection increase graph:
  - a. Calculate the percent increase in total heat rejection due to subcooling
  - b. Multiply by the N factor from "[Table 4,](#)" p. 9 to get the percent increase in net capacity due to subcooling.

**Example (using a 100T condenser):**

- At 95°F ambient and 126.1°F condensing temperature, the condenser heat rejection increase graph shows a 7.8% increase in total heat rejection due to subcooling.
  - N factor table shows a 1.34 N factor by linear interpolation.
  - This yields a system capacity of 92 tons x (1 + 7.8% x 1.34) = 102 tons.
11. If necessary, use the values in the Altitude Correction Multiplier table to adjust the system capacity for altitude.
  12. Compare this result with the design capacity and condensing temperature.
 

*Note: In the example above, the required cooling load is 101 tons. Therefore, the 100T CAUJ is the proper selection.*
  13. Repeat steps 2 through 12 above as necessary to achieve the most economic condenser selection.

**Note:** Evaporator selection must also meet performance requirements. For this example, the evaporator needs to provide at least 105 tons at 45°SST. A conservative estimate for liquid temperature entering the evaporator is the SCT minus the design subcooling (125.1 - 15°F = 110.1°F for the example above). Contact Trane Applications if excessive refrigerant line lengths or pressure drops are required.



# Model Number Description

## Digit 1 – Unit Type

C = Condenser

## Digit 2 – Condenser

A = Air-Cooled

## Digit 3 – System Type

U = Upflow

## Digit 4 – Development Sequence

J = Third

## Digit 5, 6, 7 – Nominal Capacity

C20 = 20 Tons

C25 = 25 Tons

C30 = 30 Tons

C40 = 40 Tons

C50 = 50 Tons

C60 = 60 Tons

C80 = 80 Tons

D10 = 100 Tons

D12 = 120 Tons

## Digit 8 – Voltage and Start Characteristics

E = 200/60/3 XL (80 to 120 tons only)

F = 230/60/3 (80 to 120 tons only)

G = 200–230/60/3 (20 to 60 tons only)

4 = 460/60/3 XL

5 = 575/60/3 XL

## Digit 9 – Condenser Circuit

1 = Single (20 to 30 tons)

2 = Dual (40 to 120 tons)

## Digit 10 – Design Sequence

Factory Assigned

## Digit 11 – Ambient Control

0 = Standard

1 = 0°F

## Digit 12 – Agency Approval

0 = None

3 = cULus (60 Hz only)

## Digit 13 – Corrosion Protected Condenser Coil

0 = None

J = Corrosion Protected Condenser Coil

## Digit 14 – Unit Isolation

1 = Spring Isolator

2 = Neoprene Isolators (20 to 60 tons only)

**Note:** The service digit for each model number contains 14 digits. All 14 digits must be referenced.



# General Data

**Table 6. General data – CAUJ condensers**

Unit Size (tons)		20	25	30	40	50	60	80	100	120
<b>Condenser Fan Data</b>										
Type/Drive Type		Prop/Direct								
Qty		2	3	3	4	6	6	8	12	12
Diameter	in	26	26	26	26	26	26	26	26	26
Power/motor	hp	1.0	1.0	1.0	1.0	1.0	1.0	1.0	1.0	1.0
Nominal Total Airflow	cfm	14600	20700	20700	26790	36890	40490	56490	73890	76280
<b>Condenser Coil Data</b>										
Type		Microchannel								
Number of Coils		2	2	2	2	2	2	4	4	4
Size	in	42x71	42x71	42x71	59x71	51x96	51x96	59x71	51x96	64x96
Face Area	ft <sup>2</sup>	41.4	41.4	41.4	58.2	68.0	68.0	116.4	136.0	170.7
Rows/Fin Per Ft.		1/240	1/240	1/240	1/240	1/240	1/240	1/240	1/240	1/240
Storage Capacity <sup>(a)</sup>	lbs	18.7	18.7	18.7	23.5	25.0	25.0	47.1	50.0	62.9
<b>Refrigerant Data<sup>(b)</sup></b>										
Type		R-410A								
Operating Charge <sup>(c)</sup>	lbs	11.9	11.8	11.8	22.7	23.4	23.8	57.1	59.1	65.3
<b>Outdoor Air Temperature for Mechanical Cooling</b>										
Standard Ambient Operating Range	°F	40-125	40-125	40-125	40-125	40-125	40-125	40-125	40-125	40-125
Low Ambient Option	°F	0-125	0-125	0-125	0-125	0-125	0-125	0-125	0-125	0-125

<sup>(a)</sup> Condenser storage capacity is given at conditions of 95°F outdoor temperature, and 95% full.

<sup>(b)</sup> Condensing units are shipped with nitrogen holding charge only.

<sup>(c)</sup> Operating charge is approximate for condensing unit only, and does not include charge for low side or interconnecting lines. Condensing units are shipped with a nitrogen holding charge only.



# Performance Data

## Performance Adjustment Factors

Figure 2. Condenser heat rejection increase due to subcooling (R-410A)

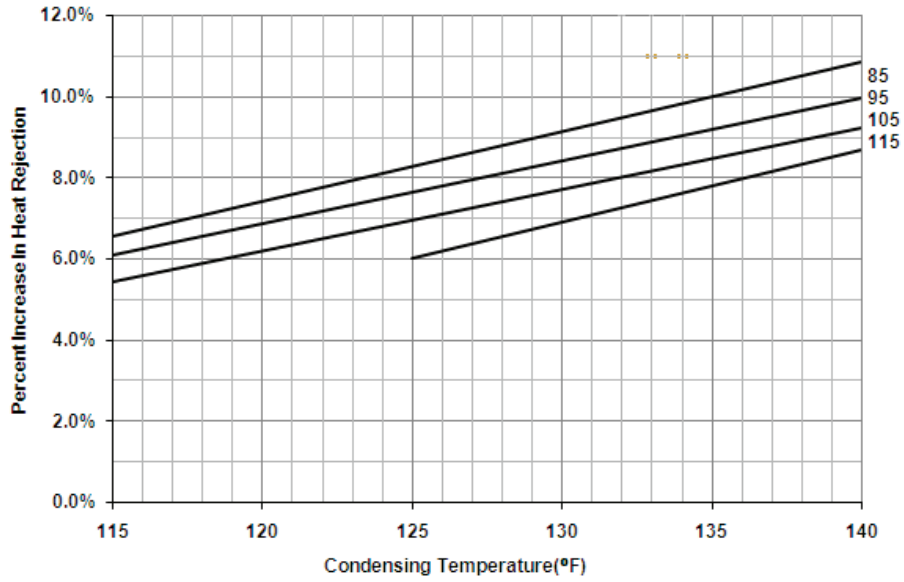


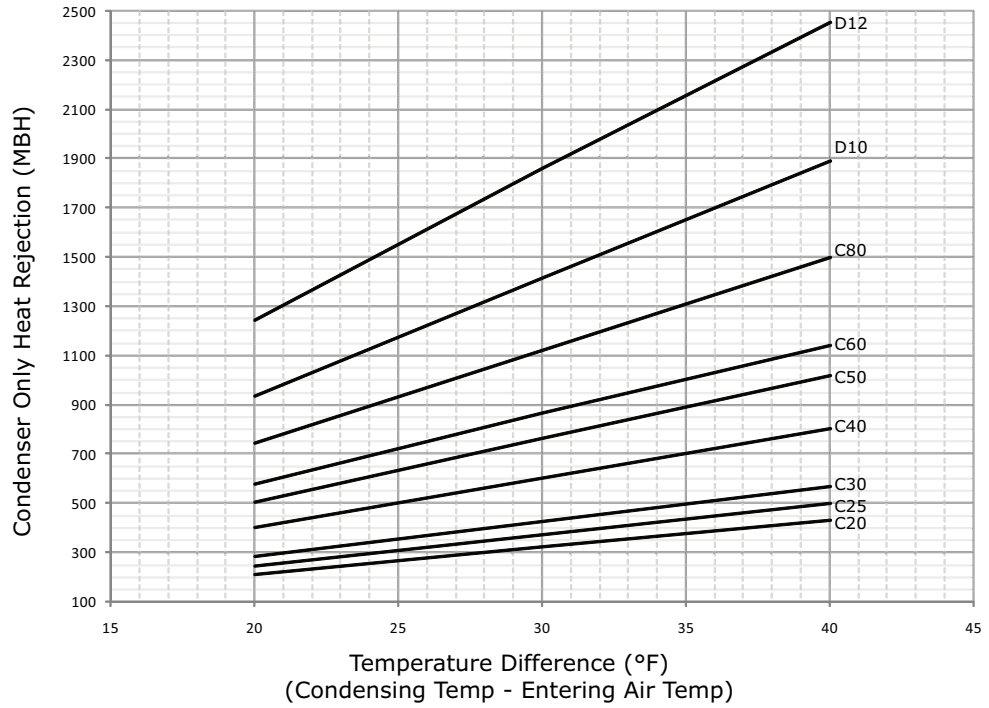
Table 7. Altitude correction multiplier for cooling capacity — air-cooled condenser

Altitude (ft)	2,000	4,000	6,000	8,000	10,000
Correction Multiplier	0.977	0.949	0.917	0.881	0.843



# Performance Data

Figure 3. Condenser heat rejection (R-410A) – 20 to 120 tons





# Electrical

*Note: Local codes may take precedence.*

**Table 8. CAUJ electrical data**

Unit Size (ton)	Rated Voltage <sup>(a)</sup>	Unit Characteristics		Condenser Fan Motor <sup>(b)</sup>				
		MCA <sup>(c)</sup>	Max Fuse <sup>(d)</sup>	kW <sup>(e)</sup>	Qty	FLA	HP	LRA
20	200-230/60/3	9.2	15	0.9	2	4.1	1	20.7
	460/60/3	4.1	15	0.9	2	1.8	1	9.0
	575/60/3	3.2	15	0.9	2	1.4	1	7.2
25	200-230/60/3	13.3	20	0.9	3	4.1	1	20.7
	460/60/3	5.9	15	0.9	3	1.8	1	9.0
	575/60/3	4.6	15	0.9	3	1.4	1	7.2
30	200-230/60/3	13.3	20	0.9	3	4.1	1	20.7
	460/60/3	5.9	15	0.9	3	1.8	1	9.0
	575/60/3	4.6	15	0.9	3	1.4	1	7.2
40	200-230/60/3	17.4	20	0.9	4	4.1	1	20.7
	460/60/3	7.7	15	0.9	4	1.8	1	9.0
	575/60/3	6.0	15	0.9	4	1.4	1	7.2
50	200-230/60/3	25.6	30	0.9	6	4.1	1	20.7
	460/60/3	11.3	15	0.9	6	1.8	1	9.0
	575/60/3	8.8	15	0.9	6	1.4	1	7.2
60	200-230/60/3	25.6	30	0.9	6	4.1	1	20.7
	460/60/3	11.3	15	0.9	6	1.8	1	9.0
	575/60/3	8.8	15	0.9	6	1.4	1	7.2
80	200/60/3	34	40	0.9	8	4.1	1	20.7
	230/60/3	34	40	0.9	8	4.1	1	20.7
	460/60/3	15	20	0.9	8	1.8	1	9
	575/60/3	12	15	0.9	8	1.4	1	7.2
100	200/60/3	50	60	0.9	12	4.1	1	20.7
	230/60/3	50	60	0.9	12	4.1	1	20.7
	460/60/3	22	25	0.9	12	1.8	1	9
	575/60/3	17	20	0.9	12	1.4	1	7.2
120	200/60/3	50	60	0.9	12	4.1	1	20.7
	230/60/3	50	60	0.9	12	4.1	1	20.7
	460/60/3	22	25	0.9	12	1.8	1	9
	575/60/3	17	20	0.9	12	1.4	1	7.2

<sup>(a)</sup> Voltage Utilization Range is +/- 10% of Rated voltage (use range): 200/60/3 (180-220), 230/60/3 (208-254), 460/60/3 (414-506), 575/60/3 (516-633)

<sup>(b)</sup> Electrical information is for each individual motor.

<sup>(c)</sup> Minimum circuit ampacity (MCA) is 125 percent of the RLA of one compressor motor plus the total RLA of the remaining motors.

<sup>(d)</sup> Maximum fuse size is permitted by NEC 440-22 is 300 percent of one motor RLA plus the RLA of the remaining motors

<sup>(e)</sup> All kW values taken at conditions of 45°F saturated suction temperature at the compressor and 95°F ambient.

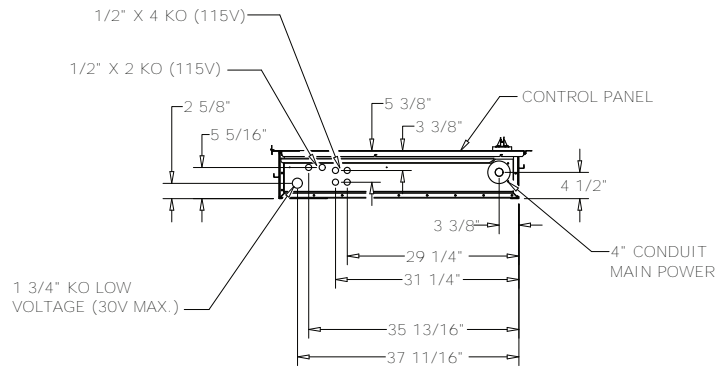
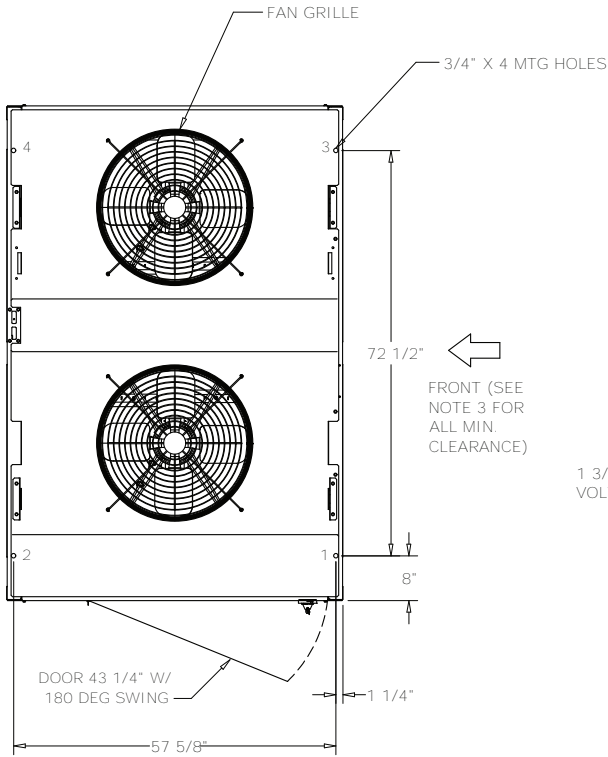


# Unit Dimensions

Figure 4. Air-cooled condenser – 20 ton

NOTES:

1. SEE CONNECTION DRAWING FOR CONNECTION LOCATION AND SIZES.
2. LOW AMBIENT DAMPER ONLY COMES WITH SELECTED UNIT.
3. FRONT OF UNIT CLEARANCE 72" . BACK OF UNIT CLEARANCE 72" . LEFT AND RIGHT SIDE OF UNIT CLEARANCE 42" .



DETAIL A

CONTROL BOX BOTTOM

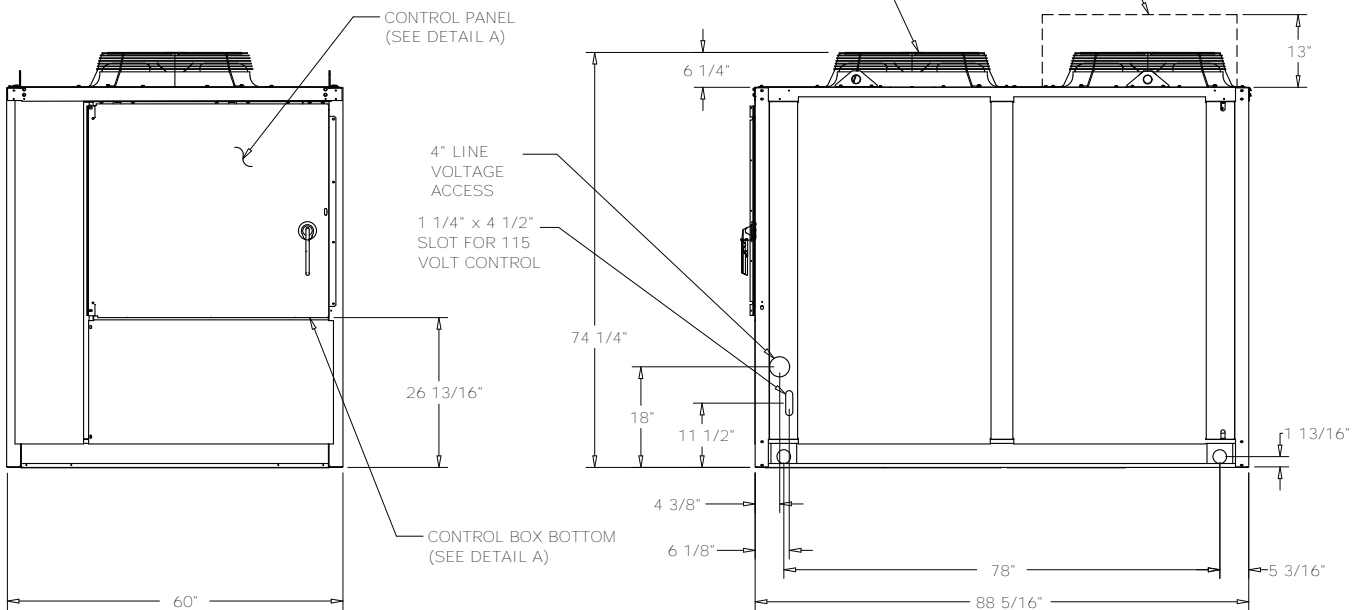
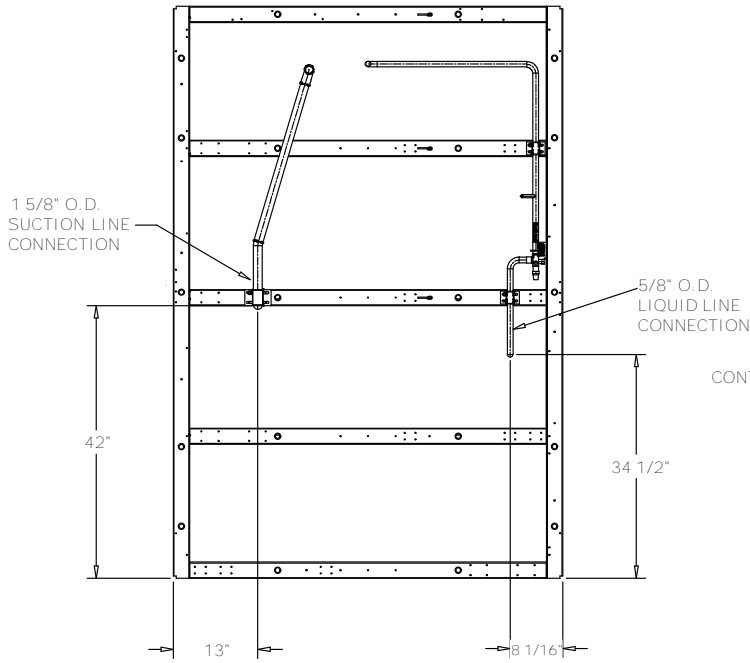




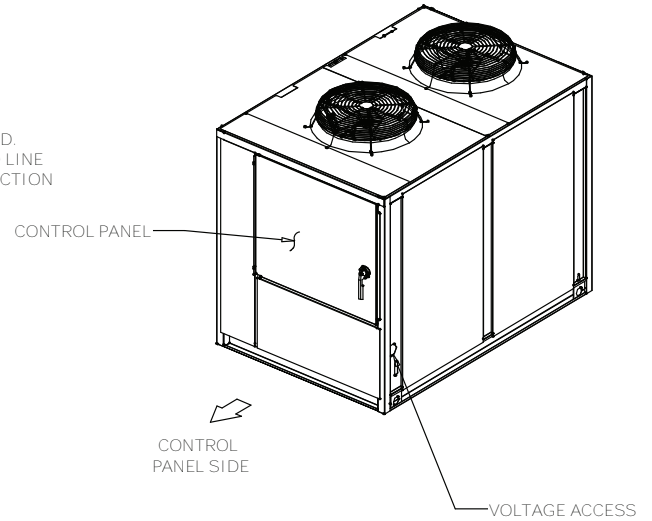
Figure 5. Air-cooled condenser connections – 20 ton

CONTROL PANEL SIDE

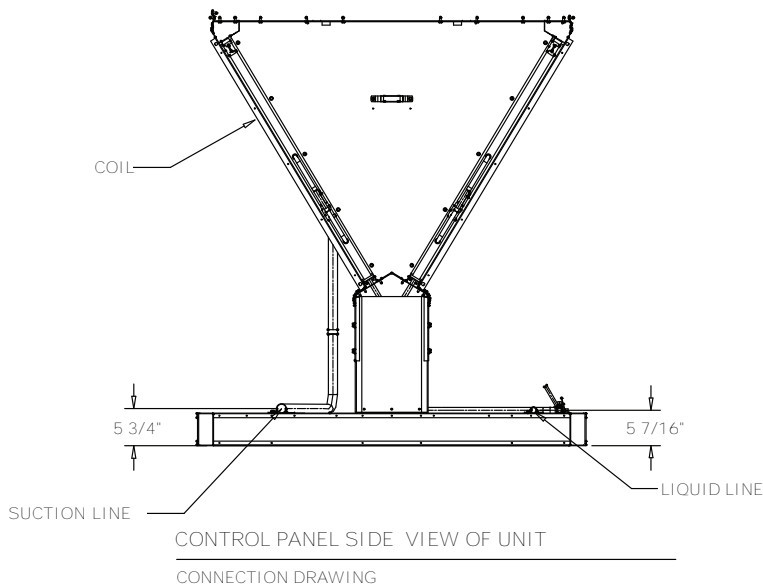


PLAN VIEW OF UNIT  
CONNECTION DRAWING

NOTES:  
1. VERIFY WEIGHT, CONNECTION, AND ALL DIMENSION WITH INSTALLER DOCUMENTS BEFORE INSTALLATION



ORIENTATION VIEW OF UNIT  
ISOMETRIC DRAWING



CONTROL PANEL SIDE VIEW OF UNIT  
CONNECTION DRAWING

20 TON UNIT

DIMENSIONAL CONNECTION DRAWING

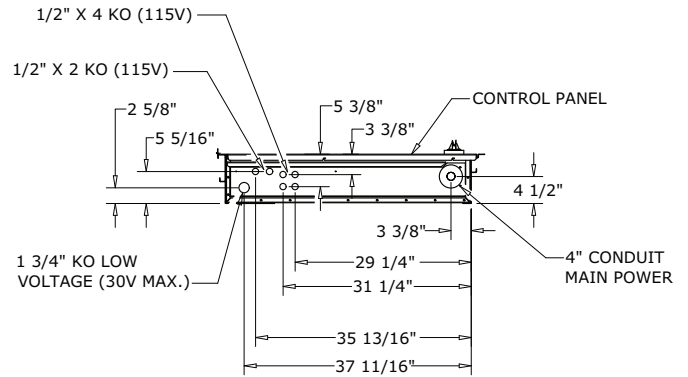
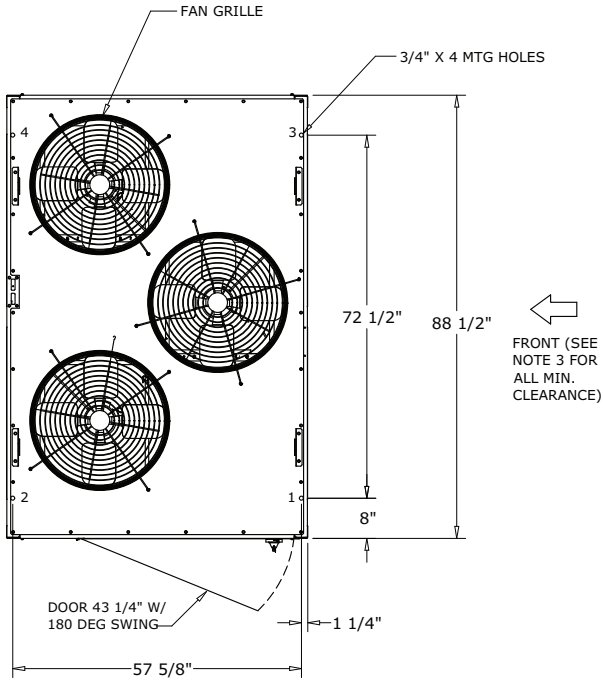


# Unit Dimensions

Figure 6. Air-cooled condenser — 25 and 30 ton

### NOTES:

1. SEE CONNECTION DRAWING FOR CONNECTION LOCATION AND SIZES.
2. LOW AMBIENT DAMPER ONLY COMES WITH SELECTED UNIT .
3. FRONT OF 20 AND 30 UNIT CLEARANCE 72" . BACK OF UNIT CLEARANCE 72". LEFT AND RIGHT SIDE OF 20 AND 30 UNIT CLEARANCE 42".



DETAIL A  
CONTROL BOX BOTTOM

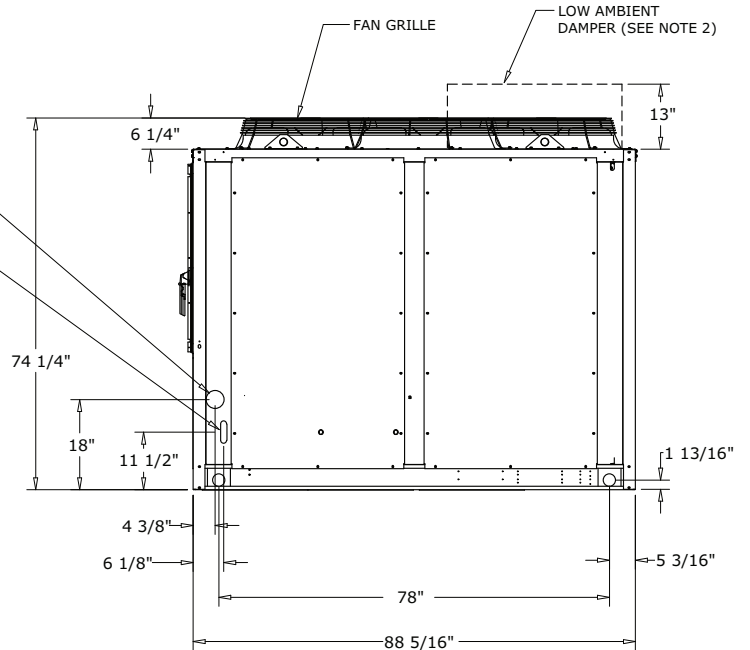
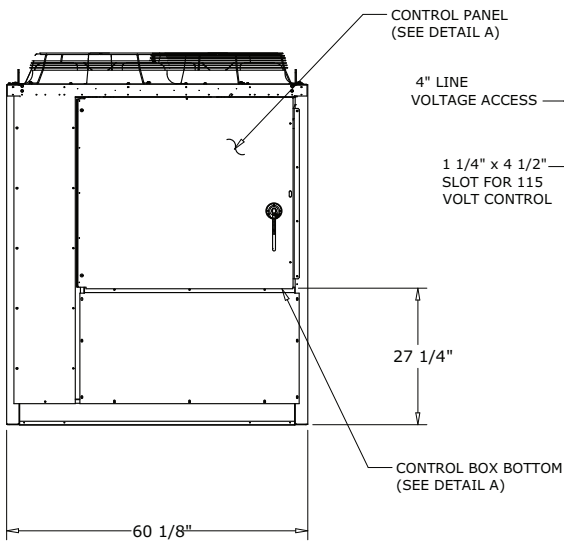
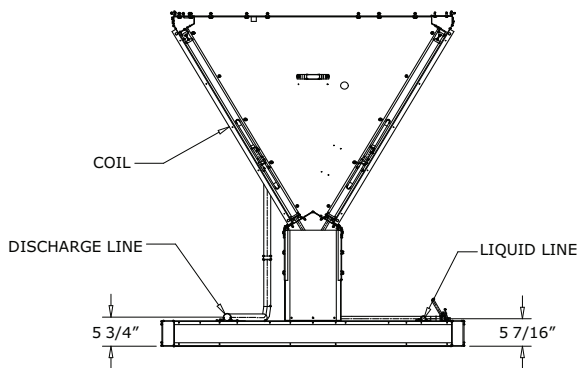
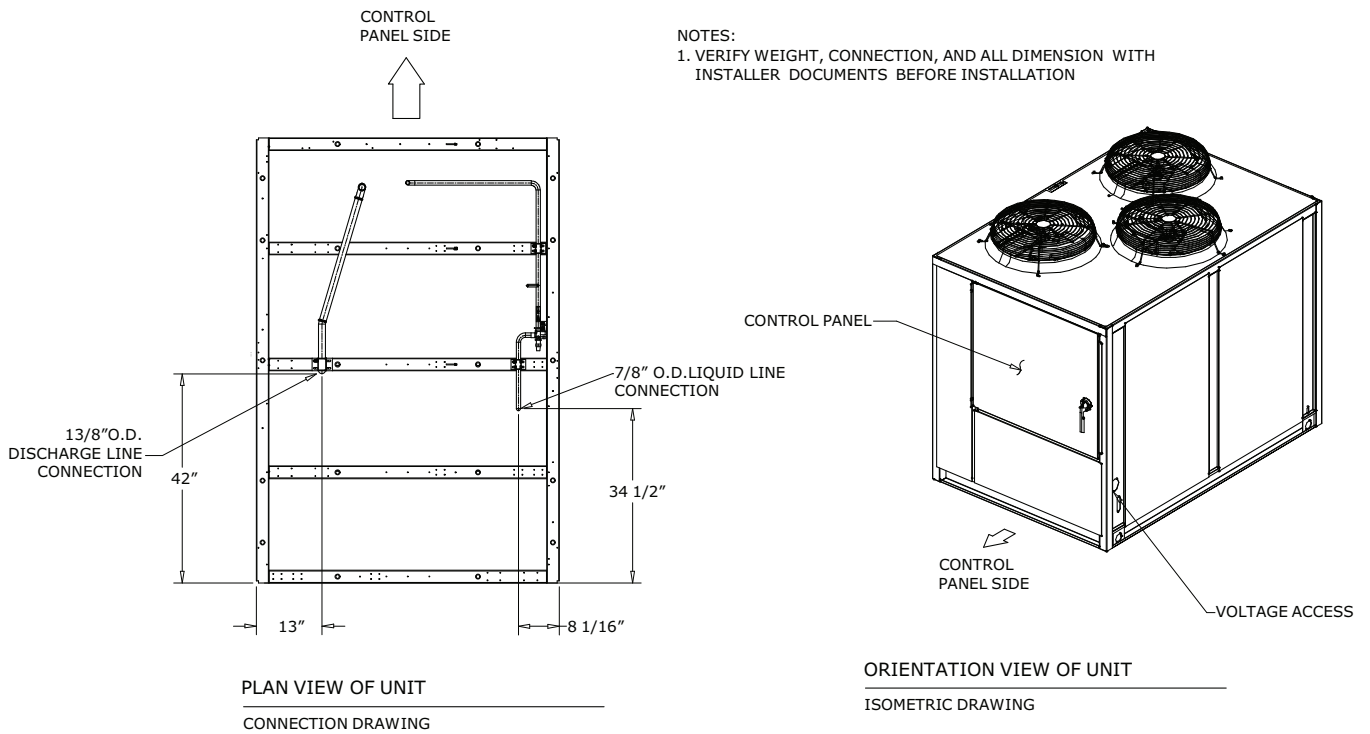


Figure 7. Air-cooled condenser connections — 25 and 30 tons



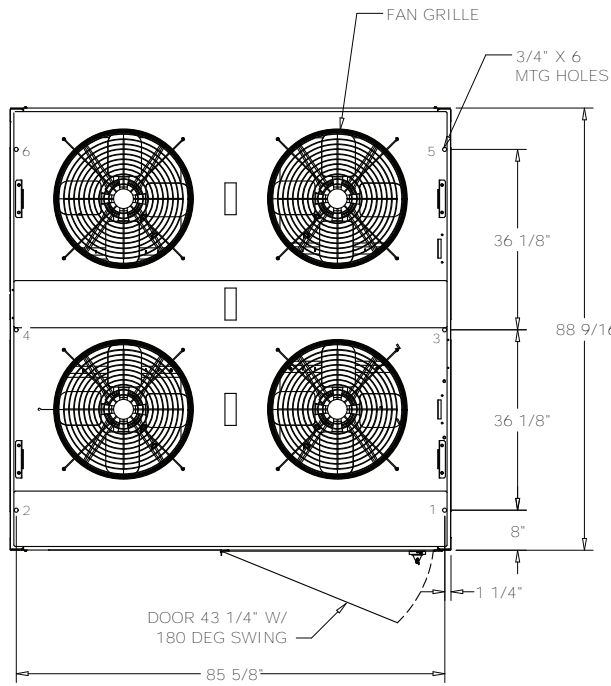
25 - 30 TON UNIT

DIMENSIONAL CONNECTION DRAWING



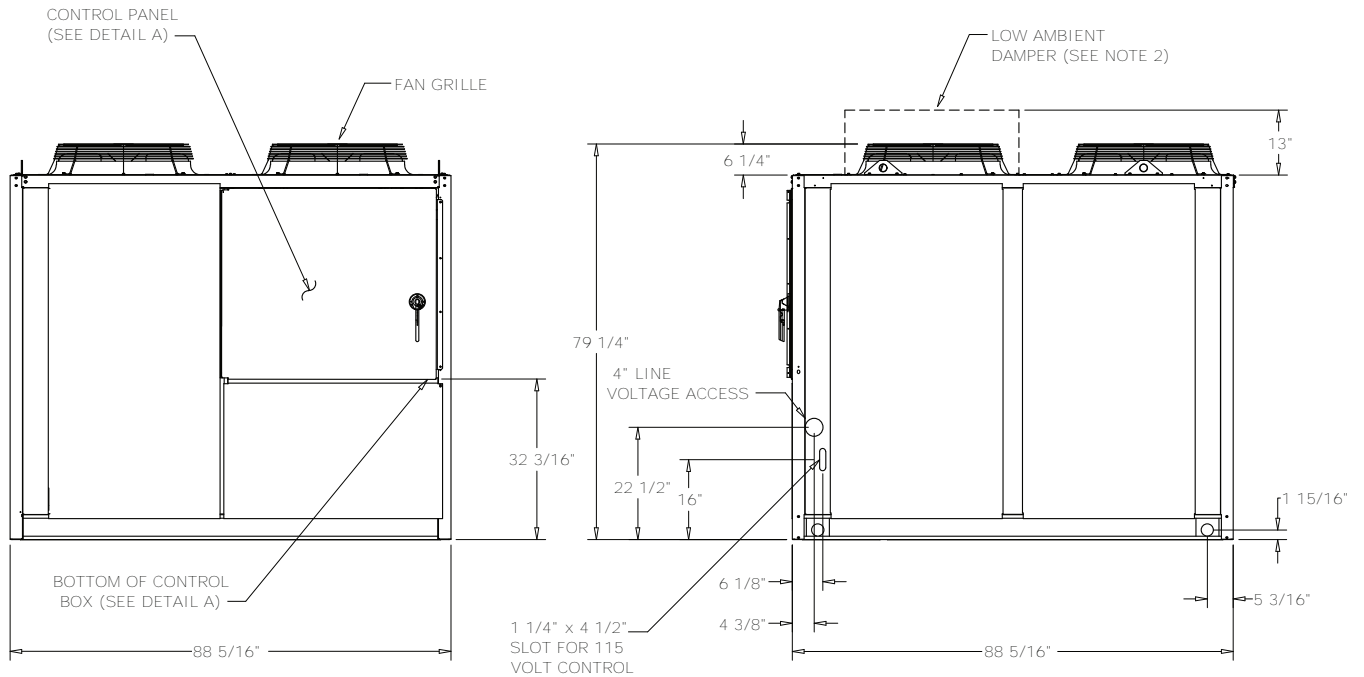
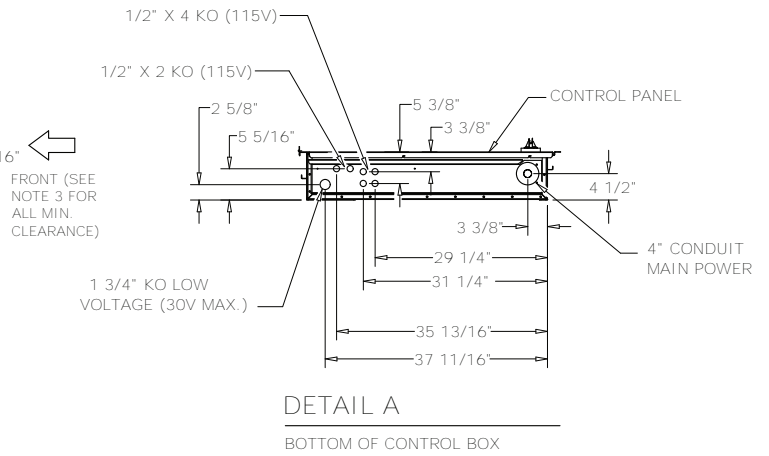
# Unit Dimensions

**Figure 8. Air-cooled condenser — 40 ton**

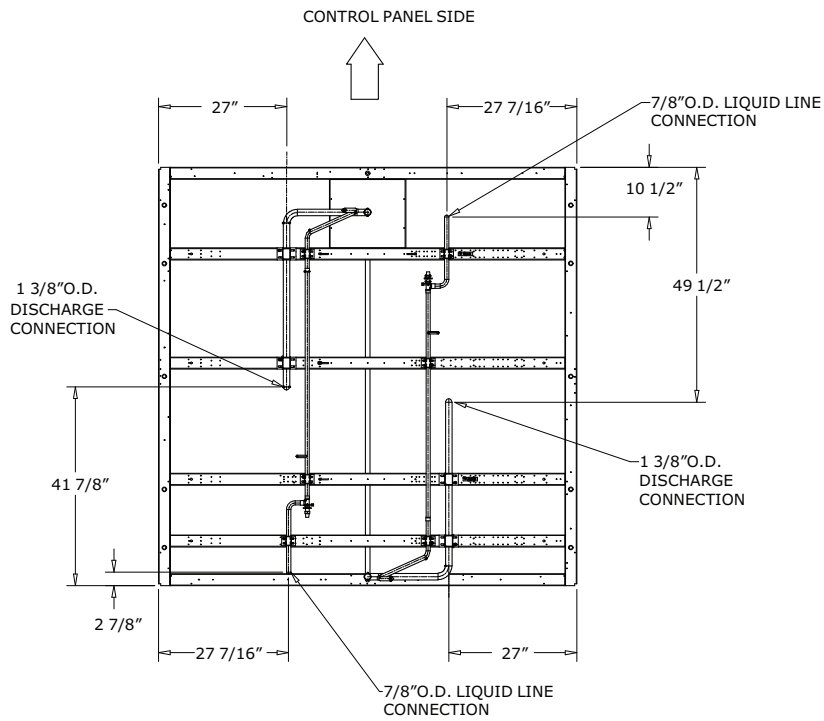


**NOTES:**

1. SEE CONNECTION DRAWING FOR CONNECTION LOCATION AND SIZES.
2. LOW AMBIENT DAMPER ONLY COMES WITH SELECTED UNIT .
3. FRONT AND BACK OF UNIT CLEARANCE 72" . LEFT AND RIGHT SIDE OF UNIT CLEARANCE 42" .

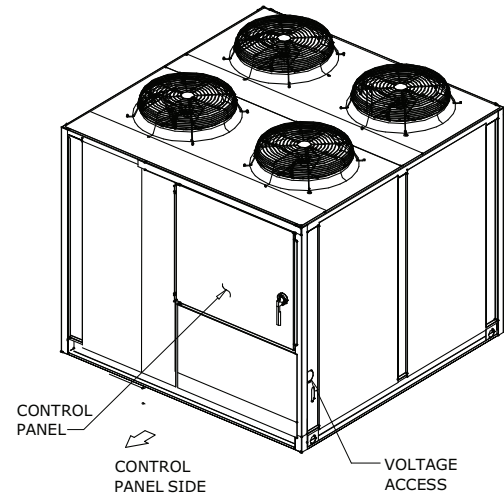


**Figure 9. Air-cooled condenser connections — 40 ton**

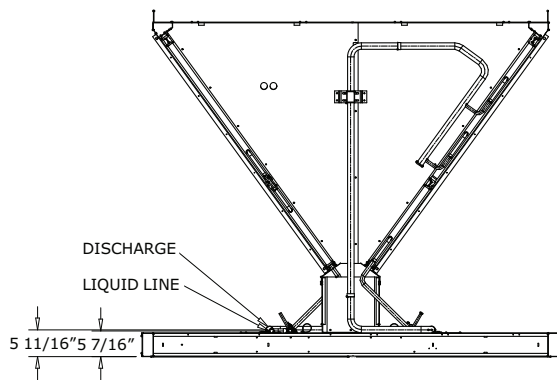


PLAN VIEW OF UNIT  
CONNECTION DRAWING

NOTES:  
1. VERIFY WEIGHT, CONNECTION, AND ALL DIMENSION WITH INSTALLER DOCUMENTS BEFORE INSTALLATION



ORIENTATION VIEW OF UNIT  
ISOMETRIC DRAWING



CONTROL PANEL SIDE VIEW OF UNIT  
CONNECTION DRAWING

**40 TON UNIT**  
DIMENSIONAL CONNECTION DRAWING



# Unit Dimensions

**Figure 10. Air-cooled condenser — 50 ton**

**NOTES:**

1. SEE CONNECTION DRAWING FOR CONNECTION LOCATION AND SIZES.
2. LOW AMBIENT DAMPER ONLY COMES WITH SELECTED UNIT .
3. FRONT AND BACK OF UNIT CLEARANCE 72" . LEFT AND RIGHT SIDE OF UNIT CLEARANCE 42" .

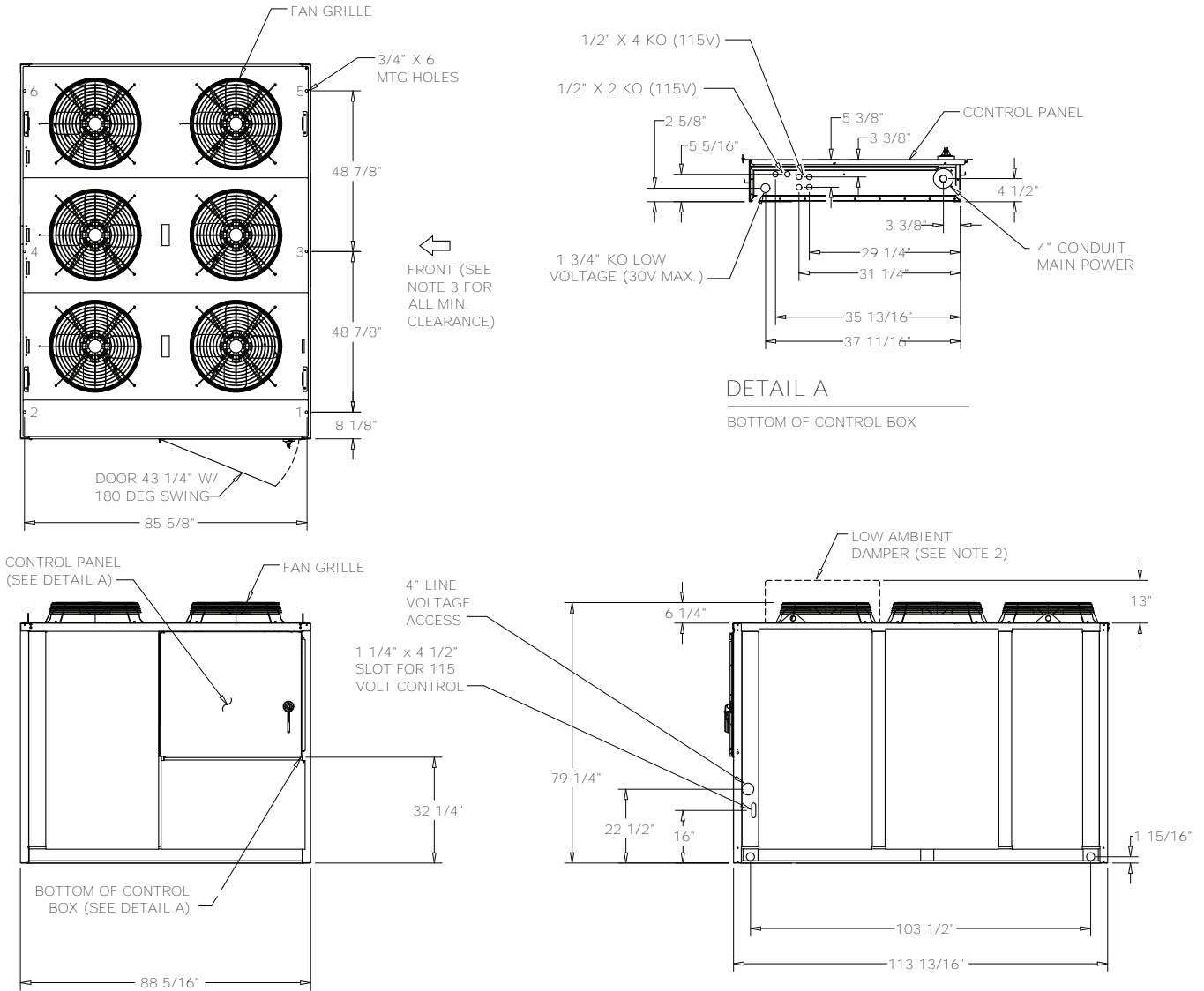
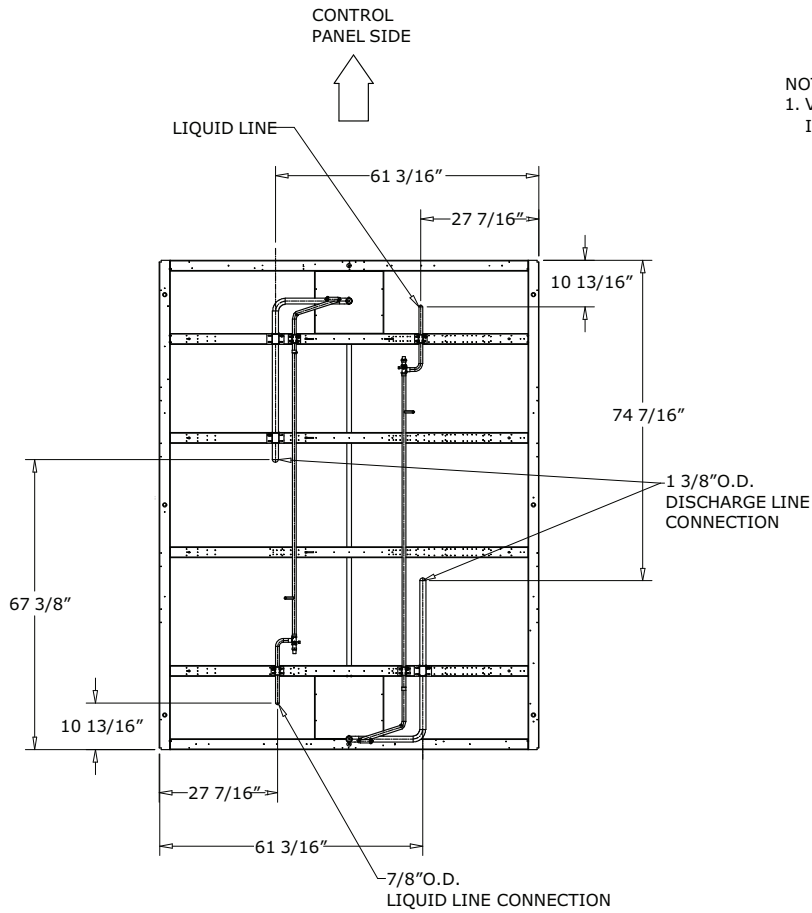


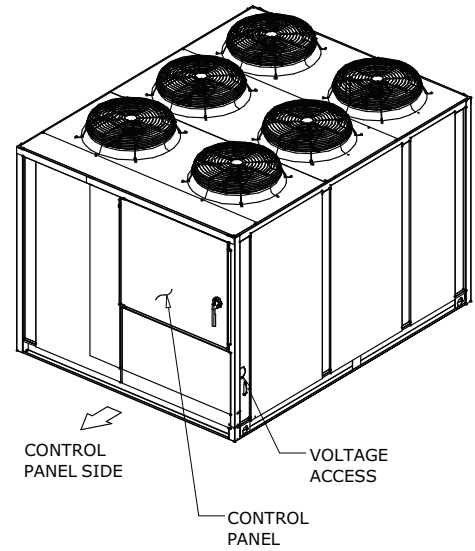
Figure 11. Air-cooled condenser connections — 50 ton



PLAN VIEW OF UNIT

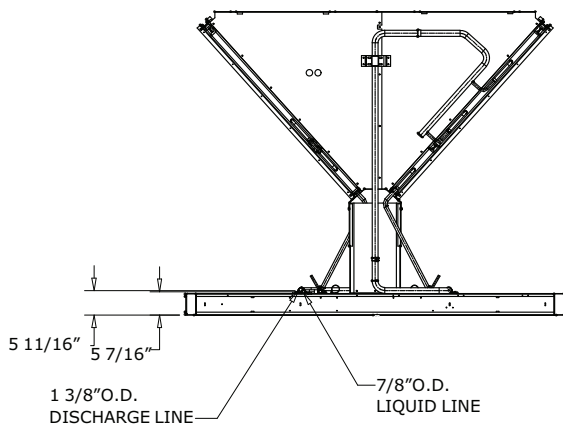
CONNECTION DRAWING

NOTES:  
1. VERIFY WEIGHT, CONNECTION, AND ALL DIMENSION WITH INSTALLER DOCUMENTS BEFORE INSTALLATION



ORIENTATION VIEW OF UNIT

ISOMETRIC DRAWING



CONTROL PANEL SIDE VIEW OF UNIT

CONNECTION DRAWING

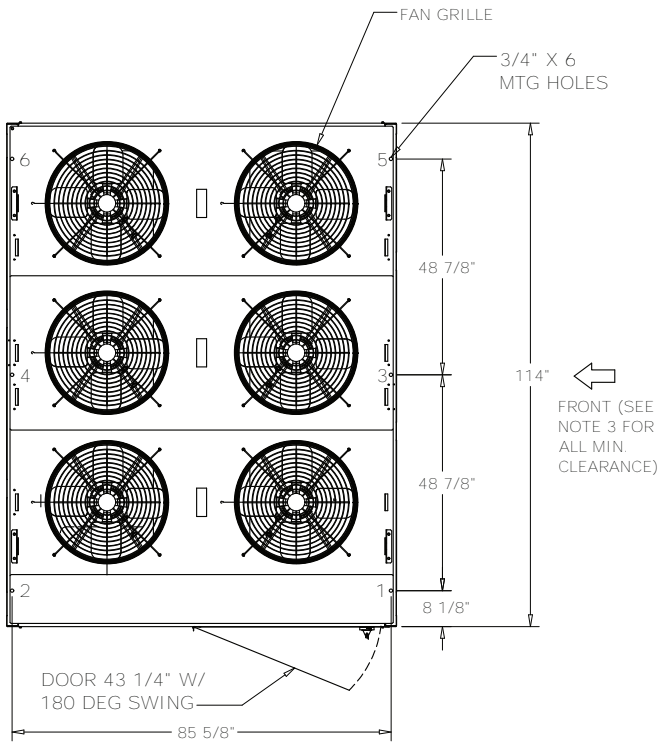
50 TON UNIT

DIMENSIONAL CONNECTION DRAWING



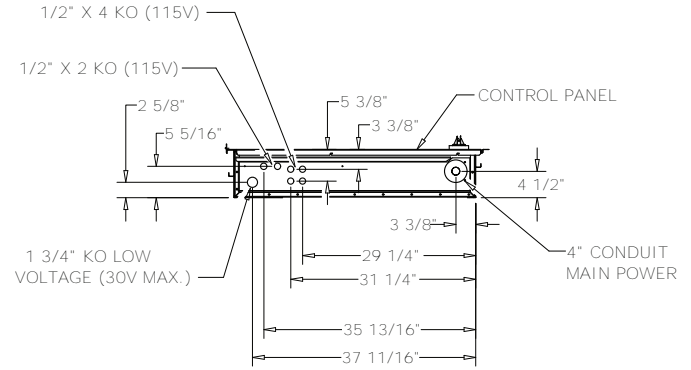
# Unit Dimensions

**Figure 12. Air-cooled condenser — 60 ton**



**NOTES:**

1. SEE CONNECTION DRAWING FOR CONNECTION LOCATION AND SIZES.
2. LOW AMBIENT DAMPER ONLY COMES WITH SELECTED UNIT.
3. FRONT AND BACK OF UNIT CLEARANCE 72". LEFT AND RIGHT SIDE OF UNIT CLEARANCE 42".



**DETAIL A**

BOTTOM OF CONTROL BOX

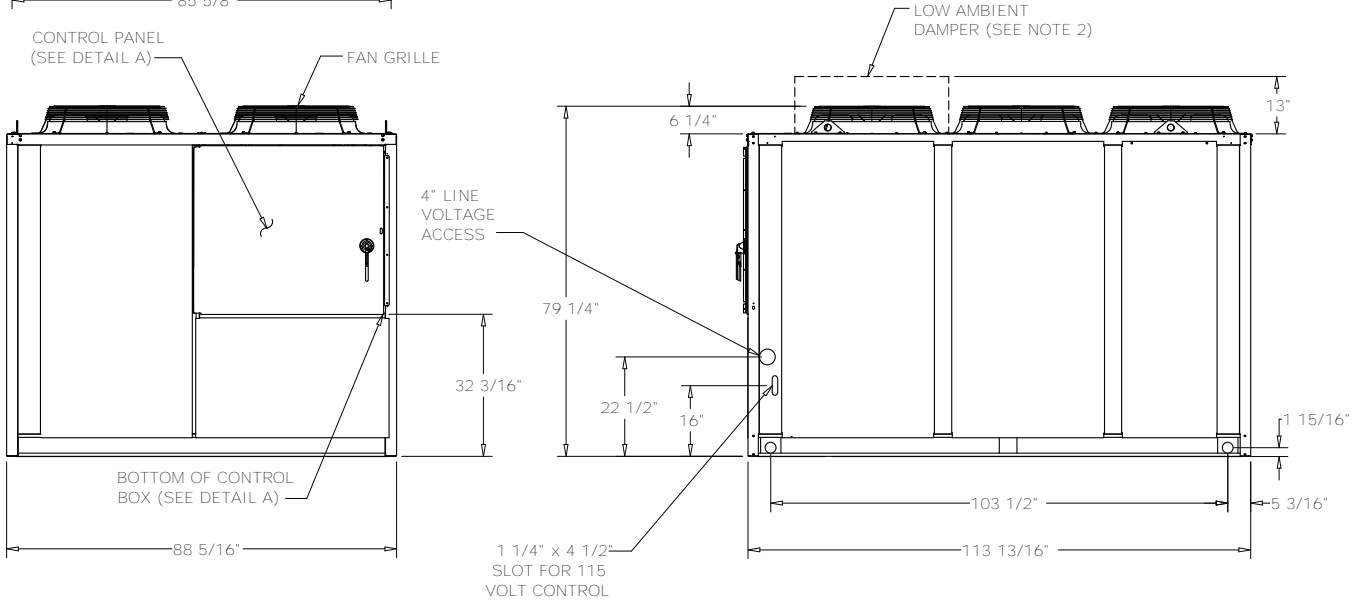
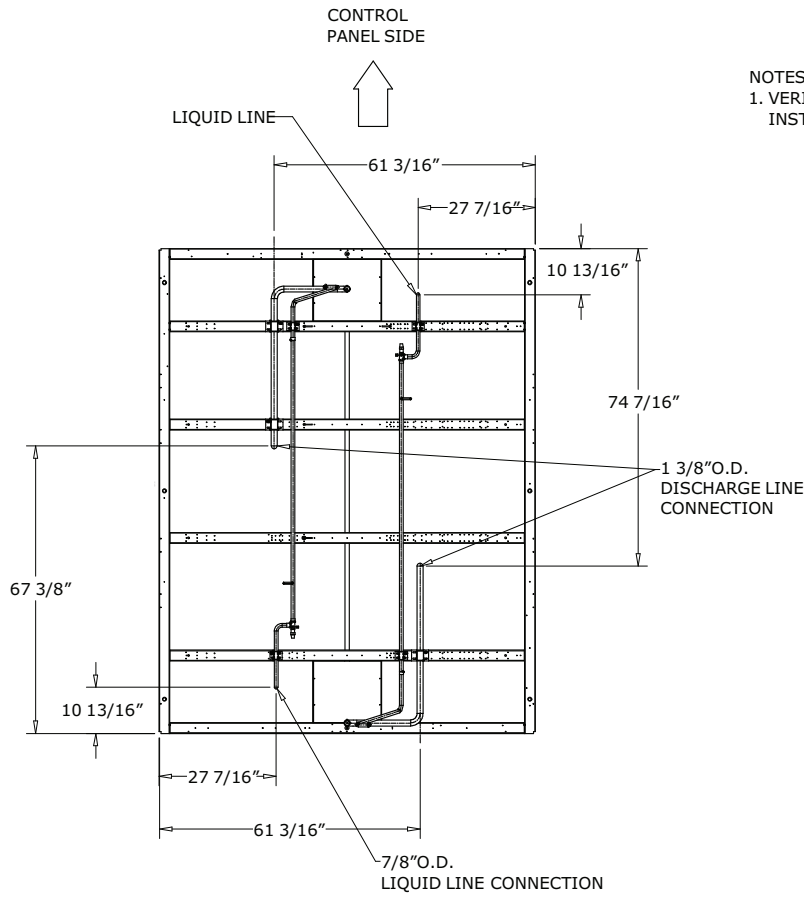




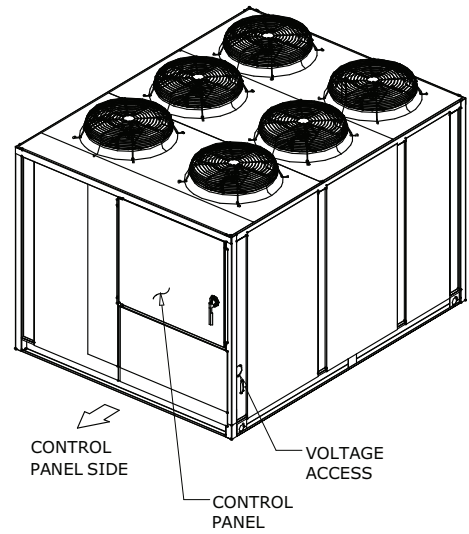
Figure 13. Air-cooled condenser connections — 60 ton



PLAN VIEW OF UNIT

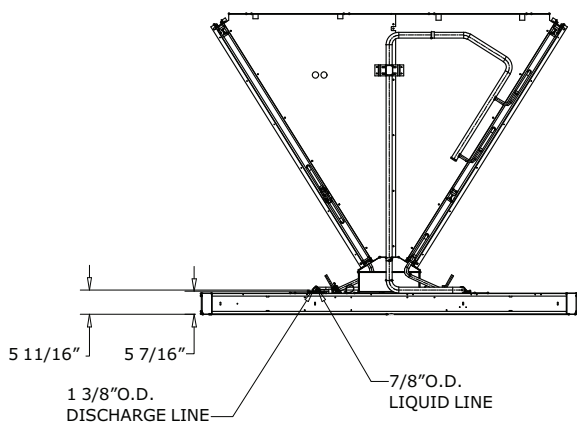
CONNECTION DRAWING

NOTES:  
1. VERIFY WEIGHT, CONNECTION, AND ALL DIMENSION WITH INSTALLER DOCUMENTS BEFORE INSTALLATION



ORIENTATION VIEW OF UNIT

ISOMETRIC DRAWING



CONTROL PANEL SIDE VIEW OF UNIT

CONNECTION DRAWING

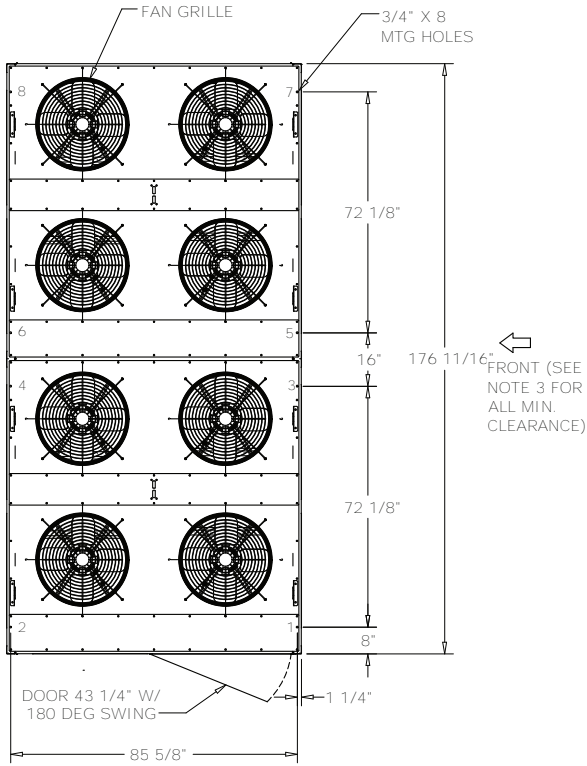
60 TON UNIT

DIMENSIONAL CONNECTION DRAWING



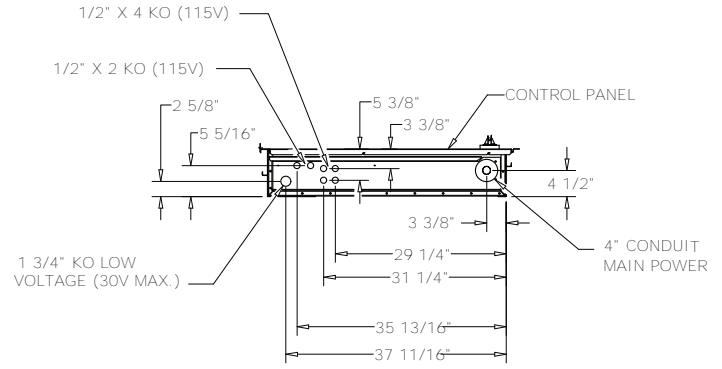
# Unit Dimensions

**Figure 14. Air-cooled condenser — 80 ton**



**NOTES:**

1. SEE CONNECTION DRAWING FOR CONNECTION LOCATION AND SIZES.
2. LOW AMBIENT DAMPER ONLY COMES WITH SELECTED UNIT.
3. FRONT AND BACK OF UNIT CLEARANCE 96". LEFT AND RIGHT SIDE OF UNIT CLEARANCE 48".



**DETAIL A**  
DIMENSIONAL DETAIL

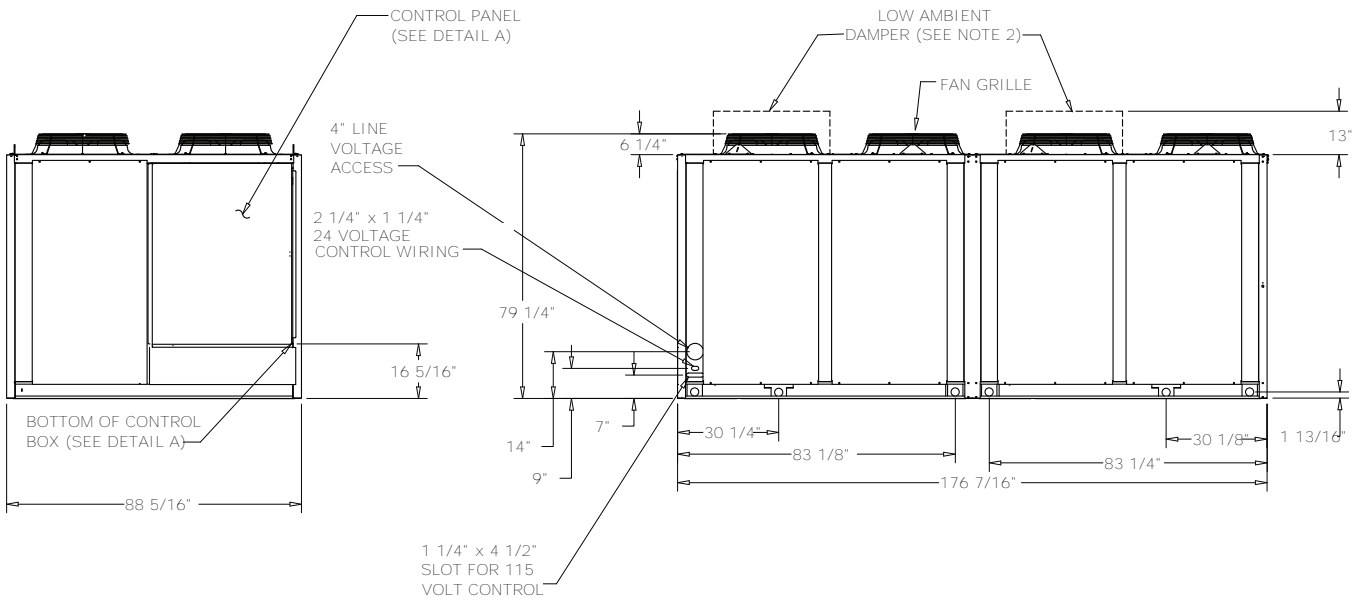
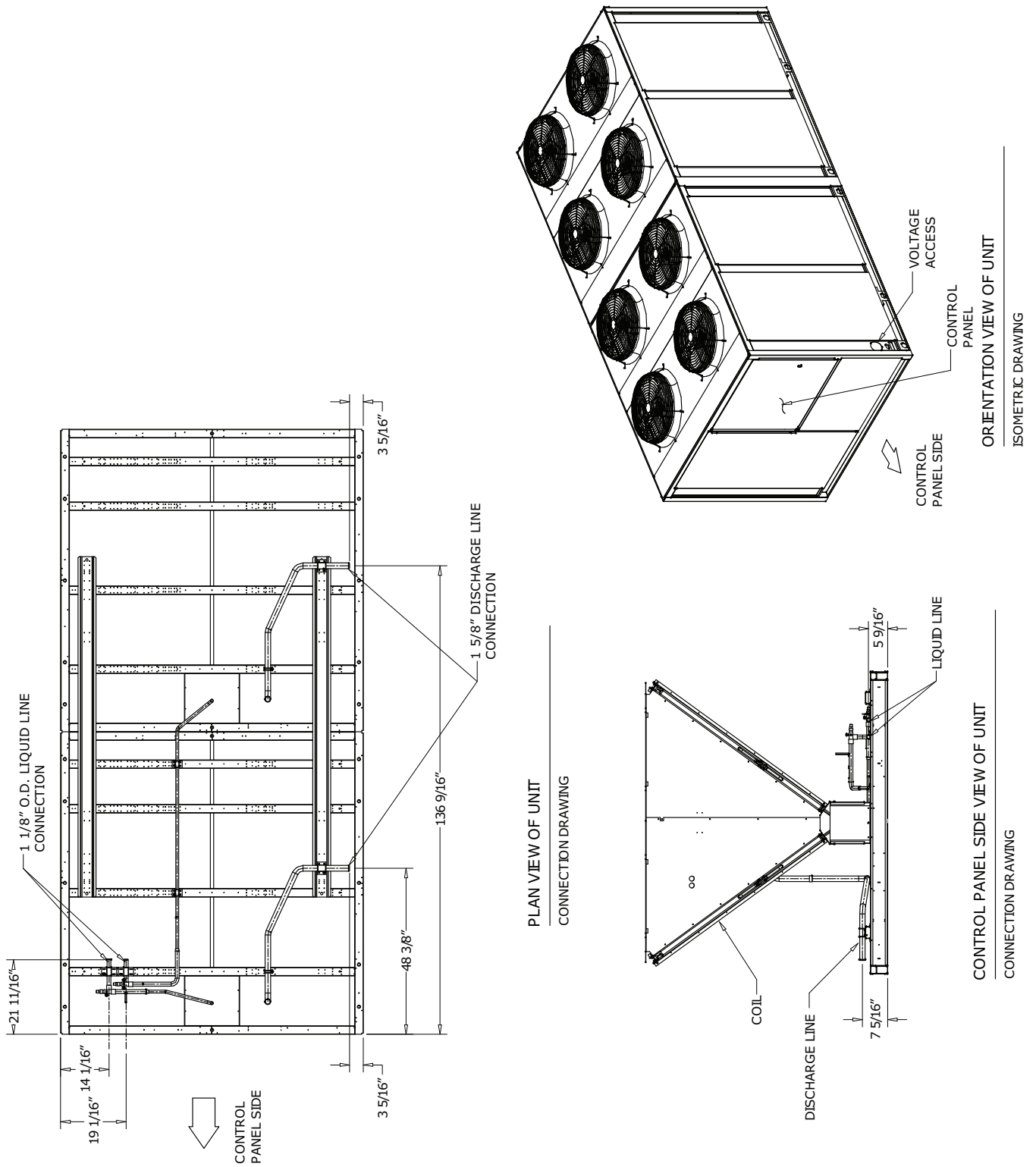


Figure 15. Air-cooled condenser connections — 80 ton





# Unit Dimensions

Figure 16. Air-cooled condenser — 100 and 120 tons

### NOTES:

1. SEE CONNECTION DRAWING FOR CONNECTION LOCATION AND SIZES.
2. LOW AMBIENT DAMPER ONLY COMES WITH SELECTED UNIT .
3. FRONT AND BACK OF UNIT CLEARANCE 96" . LEFT AND RIGHT SIDE OF UNIT CLEARANCE 48" .

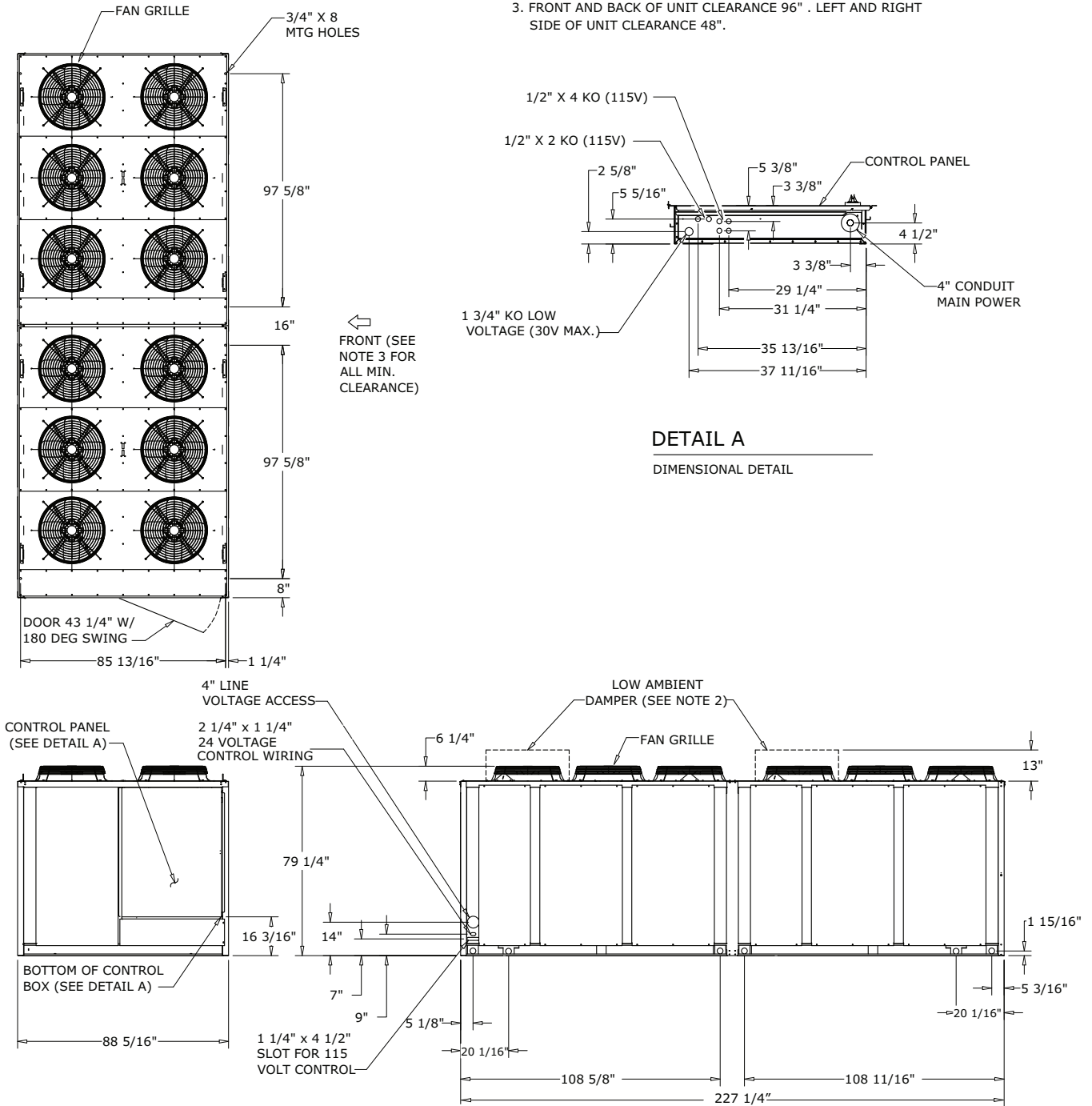
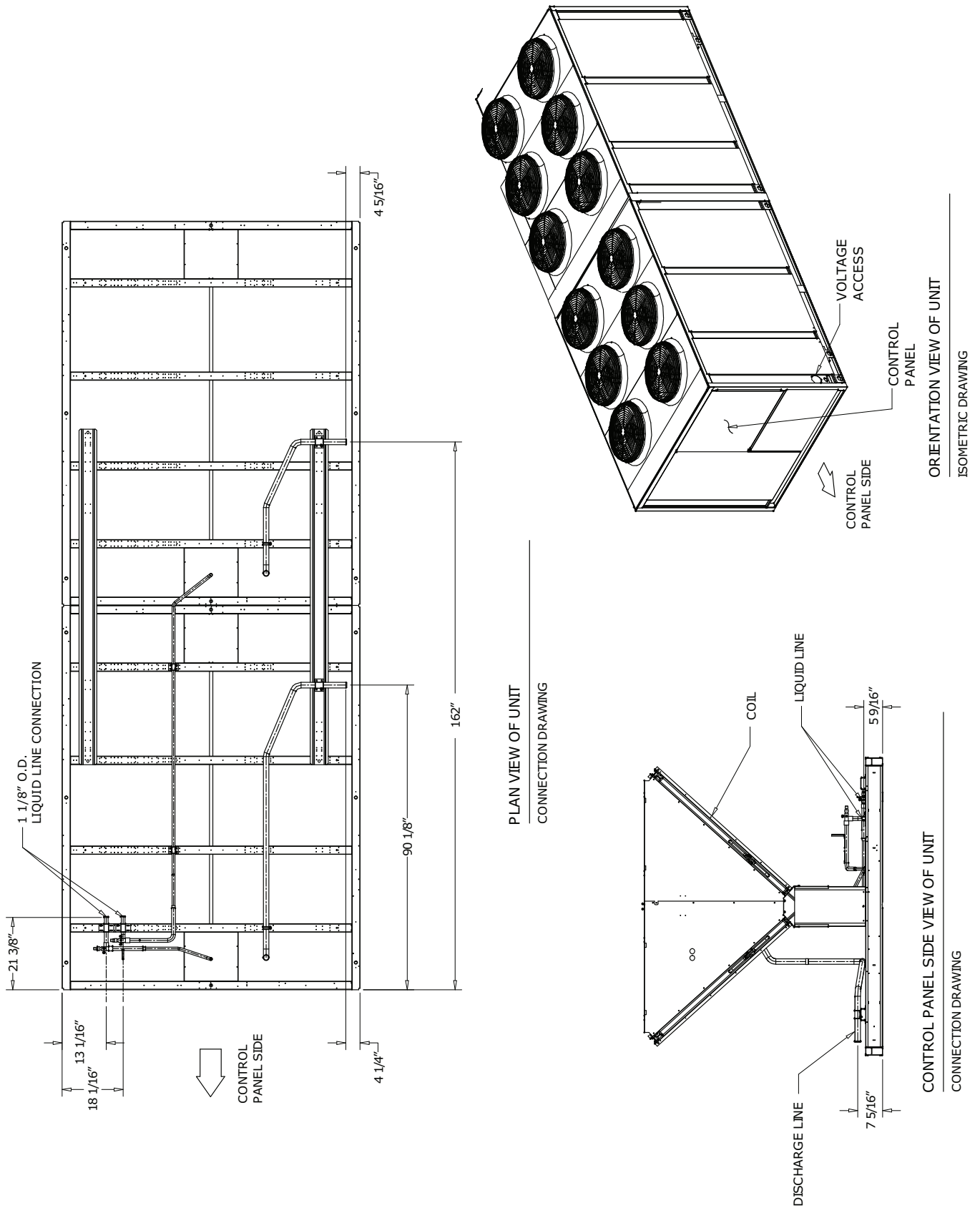


Figure 17. Air-cooled condenser connections — 100 and 120 tons





# Unit Weights

Table 9. CAUJ air-cooled condenser weights

Unit Size (tons)	Weights (lbs)	
	Shipping	Operating
20	1163	1188
25	1213	1238
30	1211	1236
40	1758	1808
50	2078	2120
60	2086	2136
80	3142	3212
100	3877	3960
120	4325	4451



# Mechanical Specifications

## Air-Cooled Condenser – Model CAUJ

### General

Units shall be constructed of 14-gauge welded galvanized steel frame with 14 and 16-gauge galvanized steel panels and access doors. Units shall have factory mounted, louvered, full-length steel grilles to protect the condenser coils and piping. Unit surface shall be phosphatized and finished with an air-dry paint. This air-dry paint finish shall be durable enough to withstand a minimum of 672-consecutive-hour salt spray application in accordance with standard ASTM B117.

### Refrigeration Circuits

The 20 to 30 ton units shall be single circuit. The 40 to 120 ton units shall be dual circuited.

### Unit control

The control panel shall contain fan motor contactors, terminal point connection for compressor interlock and 115 volt control power transformer.

### Condenser Coils

Condenser coils shall have all aluminum microchannel coils. All coils shall be leak tested at the factory to ensure pressure integrity. The condenser coil shall be pressure tested to 650 psig.

### Condenser Fans

All condenser fans shall be vertical discharge, direct drive fans, statically balanced, with aluminum blades and zinc plated steel hubs. Condenser fan motors shall be three-phase motors with permanently lubricated ball bearings, built in current and thermal overload protection and weather-tight slingers over motor bearings.

## Options

### Low Ambient Control

Low ambient option shall allow operation down to 0°F through the use of fan cycling and head pressure control dampers. The control shall consist of a heavy gauge damper assembly that is modulated by an actuator. The actuator shall be controlled by a low ambient control module. All components are factory-mounted.

### Corrosion Protected Condenser Coil

All Aluminum Microchannel condenser coil protection shall consist of a corrosion resistant coating that shall withstand ASTM B117 Salt Spray test for 6000 hours and ASTM G85 A2 Cyclic Acidified Salt Fog test for 2400 hours. This coating shall be added after coil construction covering all tubes, headers and fin edges, therefore providing optimal protection in more corrosive environments.

### Spring Isolation Package

Spring vibration isolators shall be supplied for field installation under the unit base to minimize transmission of unit vibrations. Isolators shall consist of a cast, spring loaded, telescoping housing as the isolation medium. Mountings shall include built-in leveling bolts, resilient inserts that act as centering guides, and ribbed neoprene acoustical pads bonded to the bottom of the isolator. The kit shall include instructions for field installation.

### Neoprene Vibration Isolation Package

Neoprene-in shear isolators shall be supplied for field installation under the unit base to minimize transmission of unit vibration. The isolators shall consist of a steel top plate and base



## Mechanical Specifications

---

completely imbedded in color coded oil-resistant neoprene stock. Mountings shall have a 1/4-inch deflection. The kit shall include instructions for field installation. (Available on 20 to 60 ton units only).







Notes

---





Trane - by Trane Technologies (NYSE: TT), a global innovator - creates comfortable, energy efficient indoor environments for commercial and residential applications. For more information, please visit [trane.com](http://trane.com) or [tranetechnologies.com](http://tranetechnologies.com).

Trane has a policy of continuous product and product data improvements and reserves the right to change design and specifications without notice. We are committed to using environmentally conscious print practices.