

Ameristar™
HEATING & COOLING

AFFORDABLE DUCTLESS
SOLUTIONS FROM AMERISTAR





Cost-effective solutions for single-zone and multi-zone ductless applications

Whether providing options for single-zone or multi-zone applications, these units offer quiet, high-efficiency comfort with no ductwork.

Quiet Design

Specially designed air vent efficiently reduces operation noise, as low as 28 dB.

Turbo Function

High speed operation efficiently reaches desired temperature.

Sleep Mode Function

Temperature rises/falls automatically to maintain room comfort and save energy while you sleep.

Anti-Cold Design

To prevent blowing cold air directly to the room, the indoor coil is pre-heated.

Timer

Operate the unit automatically only when you want by setting the timer.

Convenience

Convenient accessibility with both wired and handheld remote controls

Energy Efficiency

Quickly reach the desired temperature without sacrificing your electricity bills with our higher EER/COP levels.

Robust Grill

Prevent damage without impacting airflow with our strong, hot-dip galvanized steel grill.

Intelligent Defrost

Auto defrosting is implemented if necessary. It improves the system's heating efficiency and helps you save power. (Standard on all heat pump models.)

Anti-Corrosive Coastal Coating

Increase durability and ensure continued efficiency with our special anti-corrosion coil treatment. (Standard on all heat pump models.)

Twin Rotary DC Compressor

Compressor design provides better balance and higher efficiency.

Compressor Protection

Compressor stops or delays operation if conflicts arise.

Take Comfort In Our Warranties

The Ameristar Ductless System Registered Limited Warranty terms* include: 10 years on all functional parts.



Single Zone Quick Reference

	9,000 BTUH	12,000 BTUH	18,000 BTUH	24,000 BTUH
Cooling Only 15 SERIES	M4MCW1509A M4TCS1509A	M4MCW1512A M4TCS1512A	M4MCW1518A M4TCS1518A	M4MCW1524A M4TCS1524A
Heat Pump 15 SERIES	M4MHW1509A M4THS1509A	M4MHW1512A M4THS1512A	M4MHW1518A M4THS1518A	M4MHW1524A M4THS1524A
Heat Pump 18 SERIES Low Ambient Heating	M4MLW1809A M4TLS1809A	M4MLW1812A M4TLS1812A	M4MLW1818A M4TLS1818A	M4MLW1824A M4TLS1824A
Heat Pump 22 SERIES 115 Volt	M4MHW2209A M4THS2209A	M4MHW2212A M4THS2212A		

For complete equipment / combination selections, installation instructions and warranty information, please refer to Product Data/Ratings and/or Installers Guides and Limited Warranty Handbooks.

* Registered Limited Warranty terms are available when you register within 60 days of installation. You can register online at Ameristarhvac.com, otherwise Ameristar's Base Limited Warranty terms will apply. Base Limited Warranty information on specific products can be found on Ameristar.com. Ask your dealer for full warranty information at time of purchase. Warranties are for residential and multi-family use only, some exclusions may apply.

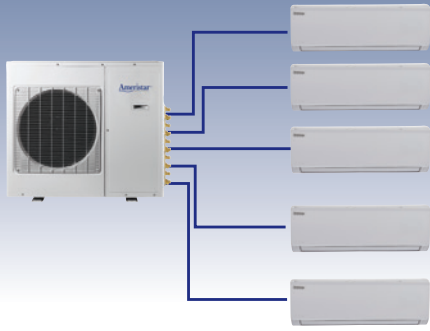

Multi Zone Quick Reference 15 SERIES

Multi-Zone Heat Pumps - Outdoor

18,000 BTUH	24,000 BTUH	30,000 BTUH	36,000 BTUH	42,000 BTUH
M4THM1518A	M4THM1524A	M4THM1530A	M4THM1536A	M4THM1542A
				

Energy Efficiency

Efficiently reach the desired temperature without sacrificing your electricity bills with our higher EER/COP levels.

Robust Grill

Prevent damage without impacting airflow with our strong, hot-dip galvanized steel grill.

Intelligent Defrost

Auto defrosting is implemented if necessary. It improves the system's heating efficiency and helps you save power. (Standard on all heat pump models.)

Compressor Protection

Compressor stops or delays operation if conflicts arise.

Twin Rotary DC Compressor

Provides better balance and higher efficiency.

Anti-Corrosive Coastal Coating

Increase durability and ensure continued efficiency with our special anti-corrosion coil treatment. (Standard on all heat pump models.)

Multi-Zone Heat Pumps - Indoor Options

	9000 BTUH	12000 BTUH	18000 BTUH	24000 BTUH
High Wall Mounted	M4MHW1509A	M4MHW1512A	M4MHW1518A	M4MHW1524A
				

Quiet Design

Specially designed air vent efficiently reduces operation noise, as low as 26 dB.

Compact Design

The compact construction and simple structure make the console and floor/ceiling models easy to install and maintain.

Turbo Function

High speed operation efficiently reaches desired temperature.

Sleep Mode Function

Temperature rises/falls automatically to maintain room comfort and save energy while you sleep.

Auto Clean and Triple Filtration

Fan runs when unit is stopped to reduce moisture and inhibit the development of bacteria, and the triple filtration system further cleans the air that you breathe. Fan runs continuous in cooling mode, however, in heat mode, it does not.

Cold Air Prevention

Helps to prevent cold air distribution while the indoor coil pre-heats prior to blower starting while in heating mode.

Timer

Timer allows the unit to run only during specific time intervals.

Take Comfort In Our Warranties

The Ameristar Ductless System Registered Limited Warranty terms* include: 10 years on all functional parts.

* Registered Limited Warranty terms are available when you register within 60 days of installation. You can register online at Ameristarhvac.com, otherwise Ameristar's Base Limited Warranty terms will apply. Base Limited Warranty information on specific products can be found on Ameristar.com. Ask your dealer for full warranty information at time of purchase. Warranties are for residential and multi-family use only, some exclusions may apply.

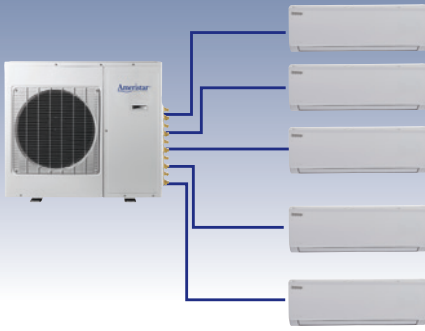

Multi Zone Sizing Combinations 15 SERIES

Ductless Multi-Zone Approved Combinations

INDOOR UNIT COMBINATIONS WITH ASSOCIATED NOMINAL CAPACITY (KBTUH)										
Outdoor Unit	One Unit		Two Units							
M4THM1518A12N 18,000 BTUH	9		9+9	12+12						
	12		9+12							
Outdoor Unit	Two Units		Three Units							
M4THM1524A13N 24,000 BTUH	9+9	9+12	9+9+9	9+12+12	12+12+12					
	9+18	12+12	9+9+12	9+9+18						
	12+18	18+18								
Outdoor Unit	Two Units		Three Units			Four Units				
M4THM1530A14N 30,000 BTUH	9+9	9+12	9+9+9	9+9+12	9+9+18	9+9+9+9	9+9+9+12	9+9+12+12		
	9+18	12+12	9+12+12	9+12+18	12+12+12					
	12+18	18+18	12+12+18							
Outdoor Unit	Two Units		Three Units			Four Units				
M4THM1536A14N 36,000 BTUH	9+9	12+18	9+9+9	9+12+18	12+12+18	9+9+9+9	9+9+12+18			
	9+12	12+24	9+9+12	9+12+24	12+12+24	9+9+9+12	9+9+18+18			
	9+18	18+18	9+9+18	9+18+18	12+18+18	9+9+9+18	9+12+12+12			
	9+24	18+24	9+9+24	9+18+24	18+18+18	9+9+9+24	9+12+12+18			
	12+12	24+24	9+12+12	12+12+12		9+9+12+12	12+12+12+12			
Outdoor Unit	Two Units		Three Units			Four Units			Five Units	
M4THM1542A15N 42,000 BTUH	9+9	12+18	9+9+9	9+12+24	12+12+24	9+9+9+9	9+9+12+24	9+12+18+18	9+9+9+9+9	9+9+9+18+18
	9+12	12+24	9+9+12	9+18+18	12+18+18	9+9+9+12	9+9+18+18	9+18+18+18	9+9+9+9+12	9+9+12+12+12
	9+18	18+18	9+9+18	9+18+24	12+18+24	9+9+9+18	9+9+18+24	12+12+12+12	9+9+9+9+18	9+9+12+12+18
	9+24	18+24	9+9+24	9+24+24	12+24+24	9+9+9+24	9+12+12+12	12+12+12+18	9+9+9+9+24	9+12+12+12+12
	12+12	24+24	9+12+12	12+12+12	18+18+18	9+9+12+12	9+12+12+18	12+12+12+24	9+9+9+12+12	9+12+12+12+18
			9+12+18	12+12+18	18+18+24	9+9+12+18	9+12+12+24	12+12+18+18	9+9+9+12+18	12+12+12+12+12

Ductless Multi-Zone Quick Reference

Multi-Zone Heat Pumps Outdoor				
18,000 BTUH	24,000 BTUH	30,000 BTUH	36,000 BTUH	42,000 BTUH
M4THM1518A12N	M4THM1524A13N	M4THM1530A14N	M4THM1536A14N	M4THM1542A15N

Multi-Zone Heat Pumps Indoor Options				
	9,000 BTUH	12,000 BTUH	18,000 BTUH	24,000 BTUH
High-Wall Mounted	M4MHW1509A1N	M4MHW1512A1N	M4MHW1518A1N	M4MHW1524A1N



Single Zone System Air Conditioner 15 SERIES

- Cooling efficiency range: 15 SEER
- Nominal capacity range: 9-24 MBH
- Power Supply: 208-230/60/1
- Low sound level (as low as 28dB)
- Refrigerant: R-410A
- Low ambient cooling to 0° F

Wireless controller Wired controller

Rated Cooling Capacity [Btu/h]	9,000 BTUH	12,000 BTUH	18,000 BTUH	22,000 BTUH
Cooling Capacity (@95F) (Btu/h) (Min/Max)	3,100 / 9,600	3,700 / 12,500	7,100 / 20,000	8,600 / 23,200
Total Capacity (W) (High/Standard/Low):	2800 / 2600 / 900	3600 / 3500 / 1100	5800 / 5200 / 2100	6600 / 6400 / 2500
SEER	15.0	15.0	15.0	15.0
EER (@95F)	10.0	9.25	9.0	9.75
RATED Volts/Phase/Frequency	208 - 230 / 1 / 60	208 / 230 / 1	208 / 230 / 1	208 / 230 / 1
Rated Power Input (W)	900	1300	1800	2260
Nominal Input Current (A)	4.0	5.8	8.0	10.0
Indoor Model Number	M4MCW1509A	M4MCW1512A	M4MCW1518A	M4MCW1524A
Dehumidifying Volume (pt./h)	1.69	2.96	3.8	5.3
Fan Motor Speed (r/min) (SH/H/M/L)	1350 / 1200 / 1050 / 750	1350 / 1200 / 1000 / 800	1350 / 1200 / 1050 / 900	1250 / 1100 / 900 / 800
Sound PRESSURE Level dB (A)(SH/H/M/L)	43 / 38 / 34 / 28	45 / 39 / 35 / 29	46 / 42 / 39 / 35	48 / 44 / 40 / 36
Outer Diameter Liquid Pipe (inch)	1/4	1/4	1/4	1/4
Outer Diameter Gas Pipe (inch)	3/8	3/8	1/2	5/8
Uncrated Dimension (W/D/H) (inch)	31.1 x 7.8 x 10.8	33.2 x 8.2 x 11.3	38.2 x 8.8 x 11.8	42.5 x 9.6 x 12.9
Net Weight /Gross Weight (lbs)	19.8 / 24.2	23.1 / 28.7	29.8 / 36.4	37.5 / 45.2
Outdoor Model Number - Cooling Only	M4TCS1509A	M4TCS1512A	M4TCS1518A	M4TCS1524A
Sound PRESSURE Level dB (A)	52	53	56	59
MCA	9.0	9.0	16.0	15.0
MOP	15.0	15.0	25.0	25.0
Working Temp Range (°F)	0 - 115	0 - 115	0 - 115	0 - 115
Outer Diameter Liquid Pipe (inch)	1/4	1/4	1/4	1/4
Outer Diameter Gas Pipe (inch)	3/8	3/8	1/2	5/8
Max Height Distance (ft)	65	65	65	65
Max Length Distance (ft)	100	100	130	130
Uncrated Dimension (W/D/H) (inch)	30.5 x 12.6 x 21.2	30.5 x 12.6 x 21.2	37.6 x 15.6 x 27.5	37.6 x 15.6 x 27.5
Net Weight /Gross Weight (lbs)	66.2 / 71.7	70.6 / 76.1	90.4 / 100.3	103.6 / 113.6
Wireless Controller	CNT07728	CNT07728	CNT07728	CNT07728
Wired Controller (sold separately)	TREWIRE1A	TREWIRE1A	TREWIRE1A	TREWIRE1A

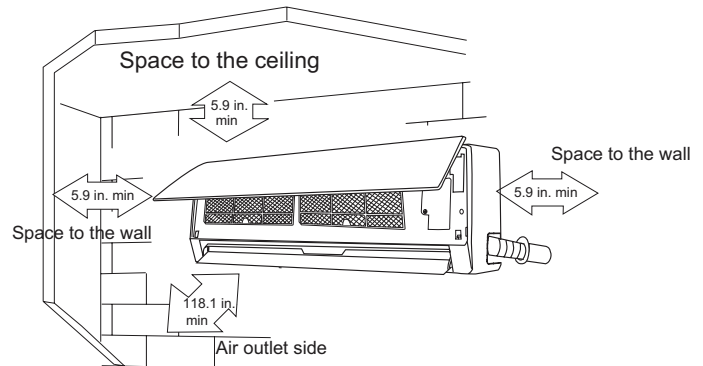
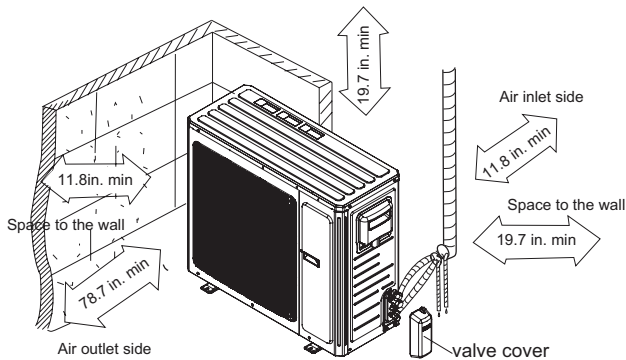



Wireless controller Wired controller

Single Zone System Heat Pump 15 SERIES

- Cooling efficiency range: 15 SEER
- Heating efficiency range: 9-HSPF
- Nominal capacity range: 9–24 MBH
- Power Supply: 208-230/60/1
- Low ambient heating to -4° F [-20° C]
- Low ambient cooling to 0° F
- Low sound level (as low as 28dB)
- Refrigerant: R-410A

Rated Cooling Capacity (Btu/h)	9,000 BTUH	12,000 BTUH	18,000 BTUH	22,000 BTUH
Rated Heating Capacity (Btu/h)	9,500 BTUH	13,000 BTUH	19,000 BTUH	23,000 BTUH
Cooling Capacity (@95F) (Btu/h) (Min/Max)	3,100 / 9,600	3,700 / 12,500	7,100 / 20,000	8,600 / 23,200
Heating Capacity (@47F) (Btu/h) (Min/Max)	3,100 / 12,000	3,900 / 14,000	7,300 / 23,400	8,600 / 26,000
Heating Capacity (@17F) (Btu/h) (Max)	5,600	8,100	12,000	13,500
Total Cooling Capacity (W) (High/Standard/Low):	2800 / 2600 / 900	3600 / 3500 / 1100	5800 / 5200 / 2100	6800 / 6400 / 2500
Total Heating Capacity (W) (High/Standard/Low):	3500 / 2700 / 900	4100 / 3800 / 1100	6800 / 5500 / 2100	7600 / 6600 / 2500
SEER	15.0	15.0	15.0	15.0
HSPF	9.0	9.0	9.0	9.0
Cooling EER (@95F)	10.0	9.25	9.0	9.8
RATED Volts/PH	208 / 230 / 1	208 / 230 / 1	208 / 230 / 1	208 / 230 / 1
Cooling Rated Power Input (W)	900	1300	1920	2260
Heating Rated Power Input (W)	800	1250	2000	2300
Cooling Nominal Input Current (A)	4.0	5.8	8.5	10.0
Heating Nominal Input Current (A)	3.6	5.6	8.9	10.2
Indoor Model Number	M4MHW1509A	M4MHW1512A	M4MHW1518A	M4MHW1524A
Dehumidifying Volume (pt./h)	1.69	2.96	3.8	5.3
Cooling Fan Motor Speed (r/min) (SH/H/M/L)	1350 / 1200 / 1050 / 750	1350 / 1200 / 1000 / 800	1350 / 1200 / 1050 / 900	1250 / 1100 / 900 / 800
Heating Fan Motor Speed (r/min) (SH/H/M/L)	1350 / 1200 / 1050 / 850	1350 / 1200 / 1000 / 900	1300 / 1200 / 1100 / 900	1150 / 1000 / 900 / 850
Sound PRESSURE Level dB (A)(SH/H/M/L)	43 / 38 / 34 / 28	45 / 39 / 35 / 29	46 / 42 / 39 / 35	48 / 44 / 40 / 36
Outer Diameter Liquid Pipe (inch)	1/4	1/4	1/4	1/4
Outer Diameter Gas Pipe (inch)	3/8	3/8	1/2	5/8
Uncrated Dimension (W/D/H) (inch)	31.1 x 7.8 x 10.8	33.2 x 8.2 x 11.3	38.2 x 8.8 x 11.8	42.4 x 9.6 x 12.8
Net Weight /Gross Weight (lbs)	19.8 / 24.2	23.2 / 28.7	29.8 / 36.4	37.5 / 45.2
Outdoor Model Number	M4THS1509A	M4THS1512A	M4THS1518A	M4THS1524A
Sound PRESSURE Level dB (A)	52	53	56	59
Cooling Working Temp Range (°F)	0 – 115	0 – 115	0 – 115	0 – 115
Heating Working Temp Range (°F)	-4 – 75	-4 – 75	-4 – 75	-4 – 75
MCA	9.0	9.0	16.0	16.0
MOP	15.0	15.0	25.0	25.0
Outer Diameter Liquid Pipe (inch)	1/4	1/4	1/4	1/4
Outer Diameter Gas Pipe (inch)	3/8	3/8	1/2	5/8
Max Height Distance (ft)	65	65	65	65
Max Length Distance (ft)	100	100	130	130
Uncrated Dimension (W/D/H) (inch)	30.5 x 12.6 x 21.2	30.5 x 12.6 x 21.2	37.6 x 15.6 x 27.3	37.6 x 15.6 x 27.3
Net Weight /Gross Weight (lbs)	65.0 / 70.6	69.5 / 75.0	95.9 / 105.8	110.3 / 120.2
Wireless Controller	CNT07728	CNT07728	CNT07728	CNT07728A
Wired Controller (sold separately)	TREWIRE1A	TREWIRE1A	TREWIRE1A	TREWIRE1A



Wireless controller

Wired controller

Single Zone Heat Pumps 18 SERIES, Low Ambient

- Cooling efficiency range: 18 SEER
- Heating efficiency range: 9.2-10.5 HSPF
- Nominal capacity range: 9-24 MBH
- Power Supply: 208-230/60/1
- Low ambient heating down to -13° F (-25° C)
- Low ambient cooling down to 0° F (-18° C)
- Low sound level (as low as 28dB)
- Refrigerant: R-410A

Rated Cooling Capacity (Btu/h)	9,200 BTUH	12,100 BTUH	17,800 BTUH	22,800 BTUH
Rated Heating Capacity (Btu/h)	10,000 BTUH	12,900 BTUH	20,000 BTUH	25,000 BTUH
Cooling Capacity (@95F) (Btu/h) [Min/Max]	3,100 / 9,600	3,750 / 12,500	3,400 / 20,000	8,600 / 24,000
Heating Capacity (@47F) (Btu/h) [Min/Max]	3,100 / 12,000	3,900 / 14,000	3,400 / 22,000	8,600 / 26,000
Heating Capacity (@17F) (Btu/h) (Max)	5,800	8,100	11,600	16,000
Total Cooling Capacity (W) [High/Standard/Low]:	2800 / 2600 / 900	3600 / 3500 / 1100	6000 / 5275 / 1000	7000 / 6450 / 2500
Total Heating Capacity (W) [High/Standard/Low]:	3500 / 2700 / 900	4100 / 3800 / 1150	6400 / 5800 / 1000	7600 / 7000 / 2500
SEER	18.5	18.5	18.0	18.4
HSPF	10.2	9.2	9.2	10.5
Cooling EER (@95F)	10.6	10.4	9.9	11.0
RATED Volts/PH	208 / 230 / 1	208 / 230 / 1	208 / 230 / 1	208 / 230 / 1
Cooling Rated Power Input (W)	850	1150	1820	2010
Heating Rated Power Input (W)	850	1250	2090	2130
Cooling Nominal Input Current (A)	4.0	5.1	8.1	8.9
Heating Nominal Input Current (A)	3.8	5.6	8.5	9.5
Indoor Model Number	M4MLW1809A	M4MLW1812A	M4MLW1818A	M4MLW1824A
Dehumidifying Volume (pt./h)	1.7	3.0	3.8	4.2
Cooling Fan Motor Speed (r/min) [SH/H/M/L]	1350 / 1200 / 1050 / 750	1350 / 1200 / 1000 / 800	1350 / 1200 / 1050 / 900	1300 / 1150 / 1000 / 850
Heating Fan Motor Speed (r/min) [SH/H/M/L]	1350 / 1200 / 1050 / 850	1350 / 1200 / 1000 / 900	1300 / 1200 / 1100 / 900	1300 / 1150 / 1000 / 850
Sound PRESSURE Level dB [A][SH/H/M/L]	43 / 38 / 34 / 28	43 / 39 / 35 / 29	47 / 44 / 41 / 35	49 / 46 / 42 / 36
Outer Diameter Liquid Pipe (inch)	1/4	1/4	1/4	1/4
Outer Diameter Gas Pipe (inch)	3/8	3/8	1/2	5/8
Uncrated Dimension (W/D/H) (inch)	31.1 x 7.9 x 10.8	33.3 x 8.2 x 11.4	38.2 x 8.8 x 11.8	42.4 x 9.7 x 12.8
Net Weight /Gross Weight (lbs)	20.9 / 25.4	23.1 / 27.6	30.9 / 37.5	37.5 / 45.2
Outdoor Model Number	M4TLS1809A	M4TLS1812A	M4TLS1518A	M4TLS1824A
Sound PRESSURE Level dB (A)	52	53	57	58
Cooling Working Temp Range (°F)	0 – 115	0 – 115	0 – 115	0 – 115
Heating Working Temp Range (°F)	-13 – 75	-13 – 75	-13 – 75	-13 – 75
MCA	9.0	9.0	16.0	16.0
MOP	15.0	15.0	25.0	25.0
Outer Diameter Liquid Pipe (inch)	1/4	1/4	1/4	1/4
Outer Diameter Gas Pipe (inch)	3/8	3/8	1/2	5/8
Max Height Distance (ft)	65	65	65	65
Max Length Distance (ft)	100	100	100	100
Uncrated Dimension (W/D/H) (inch)	30.6 x 12.6 x 21.3	30.6 x 12.6 x 21.3	37.6 x 15.6 x 27.6	37.6 x 15.6 x 27.6
Net Weight /Gross Weight (lbs)	63.9 / 69.4	69.4 / 75.0	97.0 / 106.9	103.6 / 113.5
Wireless Controller	CNT07728	CNT07728	CNT07728	CNT07728
Wired Controller (sold separately)	TREWIRE1A	TREWIRE1A	TREWIRE1A	TREWIRE1A



Wireless controller
Wired controller
Sold Separately

Single Zone Heat Pumps 22 SERIES, 115 Volt

- Cooling efficiency range: 20–22 SEER
- Nominal capacity range: 9–12 MBH
- Heating efficiency range 9.6–9.8 HSPF
- Low ambient heating to 5° F (-15° C)
- Low ambient cooling down to 0° F (-18° C)
- Power Supply: 115/60/1
- Refrigerant: R-410A
- Temperature overshoot adjustment

Rated Cooling Capacity (Btu/h)	9,000 BTUH	12,000 BTUH
Rated Heating Capacity (Btu/h)	9,500 BTUH	13,000 BTUH
Cooling Capacity (@95F) (Btu/h) (Min/Max)	2,500 / 11,600	2,600 / 13,300
Heating Capacity (@47F) (Btu/h) (Min/Max)	2,400 / 12,900	2,900 / 13,900
Heating Capacity (@17F) (Btu/h) (Max)	5,500	7,600
Heating Capacity (@5F) (Btu/h) (Min)	5,700	7,700
Total Cooling Capacity (W) (High/Standard/Low):	3390 / 2610 / 750	3900 / 3510 / 780
Total Heating Capacity (W) (High/Standard/Low):	3780 / 2760 / 690	4080 / 3810 / 840
SEER	22.0	20.0
HSPF	9.8	9.6
Cooling EER (@95F)	13.2	12.0
RATED Volts/PH	115 / 1	115 / 1
Cooling Rated Power Input (W)	680	1000
Heating Rated Power Input (W)	700	1200
Cooling Nominal Input Current (A)	8.2	12.0
Heating Nominal Input Current (A)	8.5	14.5
Indoor Model Number	M4MHW2209A	M4MHW2212A
Dehumidifying Volume (pt./h)	1.69	2.96
Cooling Fan Motor Speed (r/min) (SH/H/M/L)	1290 / 1100 / 950 / 750	1290 / 1100 / 950 / 750
Heating Fan Motor Speed (r/min) (SH/H/M/L)	1320 / 1200 / 1050 / 950	1320 / 1200 / 1050 / 950
Sound PRESSURE Level dB (A)(SH/H/M/L)	40 / 37 / 35 / 32	42 / 39 / 36 / 33
Outer Diameter Liquid Pipe (inch)	1/4	1/4
Outer Diameter Gas Pipe (inch)	3/8	3/8
Uncrated Dimension (W/D/H) (inch)	33.3 x 7.1 x 10.8	33.3 x 7.1 x 10.8
Net Weight /Gross Weight (lbs)	20.9 / 27.6	20.9 / 27.6
Outdoor Model Number	M4THS2209A	M4THS2212A
Sound PRESSURE Level dB (A)	52	52
Cooling Working Temp Range (°F)	0 – 109	0 – 109
Heating Working Temp Range (°F)	5 – 75	5 – 75
MCA	20.0	20.0
MOP	30.0	30.0
Outer Diameter Liquid Pipe (inch)	1/4	1/4
Outer Diameter Gas Pipe (inch)	3/8	3/8
Max Height Distance (ft)	33	33
Max Length Distance (ft)	50	66
Uncrated Dimension (W/D/H) (inch)	33.4 x 12.6 x 21.3	33.4 x 12.6 x 23.3
Net Weight /Gross Weight (lbs)	73.9 / 82.7	76.1 / 84.9
Wireless Controller	CNT07728	CNT07728
Wired Controller (sold separately)	TREWIRE1A	TREWIRE1A

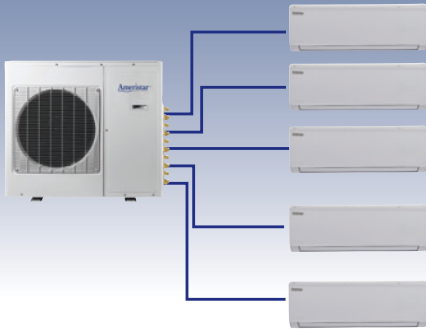

Multi Zone Heat Pumps 15 SERIES Outdoor

- Flexibility to accommodate to different applications
- Connect up to 5 indoor units to a single condensing unit
- Capacity range: 18 – 42 MBH
- Efficiency level: 15 SEER
- Refrigerant: R-410A
- Heat pump systems
- Low ambient heating down to 5° F (-15° C)
- Low ambient cooling down to 0° F (-18° C)

Rated Cooling Capacity (Btu/h)	18,000 BTUH	26,000 BTUH	29,000 BTUH	34,000 BTUH	40,000 BTUH
Outdoor Model Number	M4THM1518A	M4THM1524A	M4THM1530A	M4THM1536A	M4THM1542A
Cooling Capacity Range [Btu/h]	7,000 - 21,000	7,500 - 33,000	7,500 - 34,000	8,530 - 34,120	8,530 - 46,400
Rated Heating Capacity	19,000	29,000	30,500	35,800	44,500
Heating Capacity Range (@47F) [Btu/h]	8,530 - 22,600	7,500 - 35,000	7,500 - 36,000	10,660 - 40,900	10,660 - 47,750
Heating Capacity (@17F) [Btu/h] (Max)	9,600	15,000	16,500	22,000	24,800
Heating Capacity (@5F) [Btu/h] (Max)	8,600	12,100	13,300	14,400	17,600
SEER / HSPF	15.0 / 8.2	15.0 / 8.2	15.0 / 8.2	15.0 / 8.2	15.0 / 8.2
EER	10.0	8.0	8.0	7.75	9.1
RATED Volts/PH	208 / 230 / 1	208 / 230 / 1	208 / 230 / 1	208 / 230 / 1	208 / 230 / 1
Compressor Power Input (W)	1,245	2,200	2,200	2,200	3,010
Compressor RLA (A)	9.56	14.69	19.62	21.0	19.07
Fan Motor Speed (r/min)	830 / 670 / 500	690 / 600 / 500	690 / 600 / 500	820 / 640 / 560	860 / 650 / 550
Sound PRESSURE Level dB [A](SH/H/M/L)	56	56	56	59	58
Fuse (A)	20	30	45	45	50
Liquid Line Flare Connection Diameters	1/4, 1/4	1/4, 1/4, 1/4	1/4, 1/4, 1/4, 1/4	1/4, 1/4, 1/4, 3/8	1/4, 1/4, 1/4, 1/4, 3/8
Gas Pipe Flare Connection Diameters	3/8, 3/8	3/8, 3/8, 3/8	3/8, 3/8, 3/8, 3/8	3/8, 3/8, 1/2, 5/8	3/8, 3/8, 1/2, 1/2, 5/8
Max Height Distance OD to ID (ft)	16	33	33	50	50
Max Length Distance (ft) - Single Unit Each	66	66	66	66	80
Max Length Distance (ft) - Multiple Units Total	75	230	230	230	230
Uncrated Dimension (W/D/H) (inch)	35.4 x 14.9 x 23.5	37.2 x 15.6 x 27.6	37.2 x 15.6 x 27.6	39.1 x 16.8 x 31.1	42.8 x 17.3 x 43.4
Net Weight /Gross Weight (lbs)	94.8 / 105.8	134.5 / 145.5	136.7 / 147.7	152.6 / 165.2	224.9 / 247
Working Temp Range (°F)	0 - 118 / 5 - 75	0 - 118 / 5 - 75	0 - 118 / 5 - 75	0 - 118 / 5 - 75	0 - 118 / 5 - 75
MCA	13.0	20.0	26.0	28.0	29.0
MOP	20.0	30.0	45.0	45.0	50.0

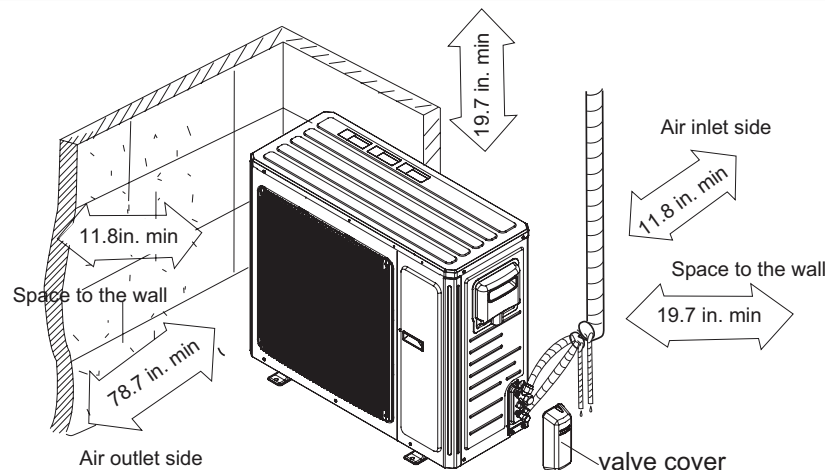



Multi Zone Heat Pumps: Indoor High Wall Mount matched with 15 Series Multi Zone Outdoor Units

- High wall mounted
- Fan Speed: 4
- Condensate pump: Sold Separately
- Remote control capable
- Louver: adjustable and oscillating
- Capacity: 9k, 12k, 18k, 24K

Rated Capacity (Btu/h)	9,000 BTUH	12,000 BTUH	18,000 BTUH	24,000 BTUH
Indoor Model Number	M4MHW1509A	M4MHW1512A	M4MHW1518A	M4MHW1524A
Rated Cooling Capacity (Btu/h)	9,000 BTUH	12,000 BTUH	18,000 BTUH	22,000 BTUH
Rated Heating Capacity (Btu/h)	9,500 BTUH	13,000 BTUH	19,000 BTUH	23,000 BTUH
RATED Volts/PH	208 / 230 / 1	208 / 230 / 1	208 / 230 / 1	208 / 230 / 1
Cooling Rated Power Input (W)	900	1300	1920	2260
Heating Rated Power Input (W)	800	1250	2000	2300
Cooling Nominal Input Current (A)	4.0	5.8	8.5	10.0
Heating Nominal Input Current (A)	3.6	5.6	8.9	10.2
Dehumidifying Volume (pt./h)	1.69	2.96	3.8	5.3
Cooling Fan Motor Speed (r/min) (SH/H/M/L)	1350 / 1200 / 1050 / 750	1350 / 1200 / 1000 / 800	1350 / 1200 / 1050 / 900	1250 / 1100 / 900 / 800
Heating Fan Motor Speed (r/min) (SH/H/M/L)	1350 / 1200 / 1050 / 850	1350 / 1200 / 1000 / 900	1300 / 1200 / 1100 / 900	1150 / 1000 / 900 / 850
Sound PRESSURE Level dB (A)(SH/H/M/L)	43 / 38 / 34 / 28	45 / 39 / 35 / 29	46 / 42 / 39 / 35	48 / 44 / 40 / 36
Outer Diameter Liquid Pipe (inch)	1/4	1/4	1/4	1/4
Outer Diameter Gas Pipe (inch)	3/8	3/8	1/2	5/8
Uncrated Dimension (W/D/H) (inch)	31.1 x 7.8 x 10.8	33.2 x 8.2 x 11.3	38.2 x 8.8 x 11.8	42.5 x 9.6 x 12.9
Net Weight /Gross Weight (lbs)	19.8 / 24.2	23.2 / 28.7	29.8 / 36.4	37.5 / 45.2
Wireless Controller	CNT07728	CNT07728	CNT07728	CNT07728
Wired Controller (sold separately)	TREWIRE1A	TREWIRE1A	TREWIRE1A	TREWIRE1A

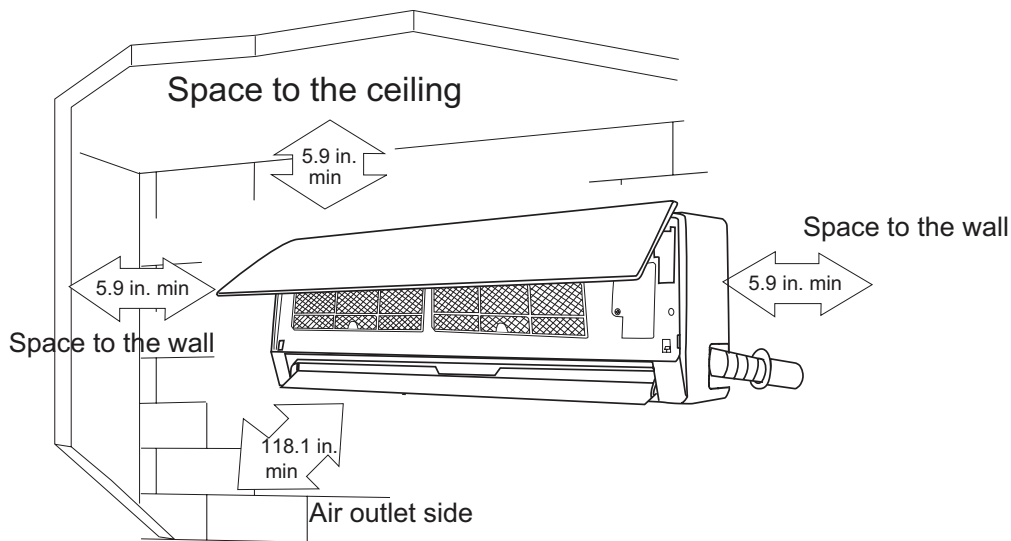



Ameristar is a brand of Ingersoll Rand. Ingersoll Rand (NYSE:IR) is a \$14 billion global business driven by a purpose to advance the quality of life by creating and sustaining safe, comfortable and efficient environments in commercial, residential and industrial markets. Our people and our market-leading brands are committed to helping meet growing, critical needs for clean and comfortable air, secure homes and buildings, safe and fresh food, energy efficiency and sustainable business practices around the world.

ameristarhvac.com