



Installation Operation Maintenance

Cond. Unit TRCE - 5 to 15 TR (Centrifugal Fan)

Cond. Unit TRAE - 5 to 25 TR (Axial Fan)

Cond. Unit CRCB - 5 to 15 TR

Cond. Unit CRCE - 5 to 15 TR

Split System

60Hz

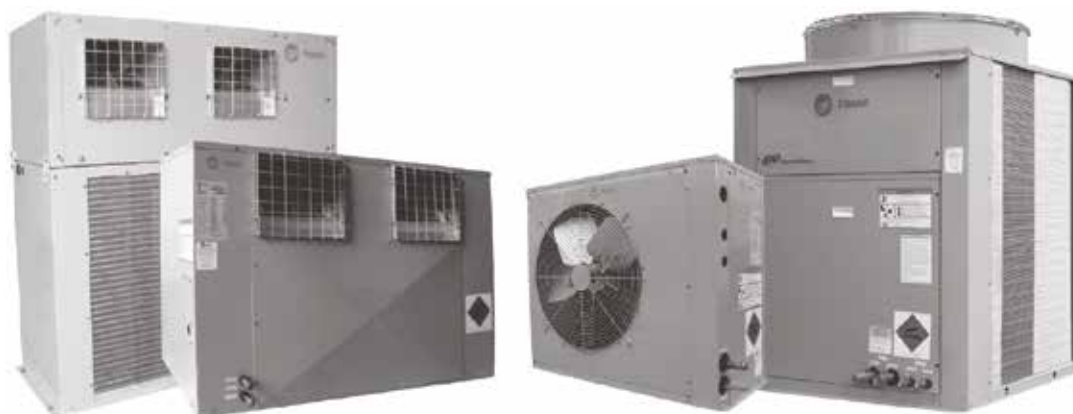

Models:

TRAE050 1C	TRAE200 1C	TRCE050 1C	CRCB050 1C	CRCE050 1C
TRAE075 1C	TRAE200 2C	TRCE075 1C	CRCB075 1C	CRCE075 1C
TRAE100 1C	TRAE250 1C	TRCE100 1C	CRCB100 1C	CRCE100 1C
TRAE100 2C	TRAE250 2C	TRCE100 2C	CRCB100 2C	CRCE100 2C
TRAE150 1C		TRCE150 1C	CRCB125 1C	CRCE125 1C
TRAE150 2C		TRCE150 2C	CRCB125 2C	CRCE125 2C
			CRCB150 1C	CRCE150 1C
			CRCB150 2C	CRCE150 2C

SAFETY WARNING

Only qualified personnel should install and service the equipment. The installation, starting up, and servicing of heating, ventilating, and air-conditioning equipment can be hazardous and requires specific knowledge and training. Improperly installed, adjusted or altered equipment by an unqualified person could result in death or serious injury. When working on the equipment, observe all precautions in the literature and on the tags, stickers, and labels that are attached to the equipment.



Important Notice

Literature History

This manual describes installation, operation and maintenance for TRAE and TRCE condensing units, which are part of Trane split system Solution Plus. For further information on Solution Plus installation, operation and maintenance, refer to literature SS-PRC002G-EN, which includes detailed information about the Solution Plus set, which includes evaporating and condensing units.

IMPORTANT:

Dimensional measuring units on this catalog are in millimeters (mm). (Except for those locally referenced).

Refrigerant Emission Control

Trane-recommended service and operation procedures must be followed in order to allow gas conservation and gas emission reduction, with a special attention to:

The refrigerant used in any type of air conditioning equipment should be recovered and/or recycled for reuse, reclaimed or completely destroyed whenever it is removed from the equipment. **Never release it into the atmosphere.**

Before starting recovery through any method, always consider the possibility of recycling or reprocessing the transferred refrigerant.

Issues involving recovered refrigerants and acceptable qualities are described in norm ARI 700.

Use safe and approved cylinders. Follow all applicable transport and safety norms when transporting refrigerant containers.

To minimize emissions during refrigerant gas transfer, use recycling equipment. Always use methods that produce the lowest possible vacuum while recovering and condensing the refrigerant inside the cylinder.

Important:

As Trane has the policy of continually improving its products, it reserves the right to change specifications and drawings without prior notice. Only technicians accredited and/or authorized by Trane should install and maintain equipment specified in this manual. If any procedure contained in this manual is ignored and/or not adopted, product warranty may be void.

Contents

I-General Data	4
II-Unit Inspection	6
III-Transport and Movement	7
IV-Refrigeration Piping (Interconnection)	8
V-Periodic Preventive	13
VI-Operational and Electric Features	15
VII-Wiring Diagram	16
VIII-Control Panel Lay Out	35
IX-Interconnection Diagram	41
X-Dimensional Data	42
XI-Application Considerations	52
XII-Standard Conversion Table	53



I-General Data

TRAE/TRCE

Tab I-01 - General Data - Condensing Units TRAE - 050 to 250

Model	050	075	100	150	200	250					
Nominal Cap.	Ton	5	7,5	10	15	20	25				
Dimensions											
Width	mm	920	930	1140	1590	1067	1067				
Depth	mm	420	620	800	800	1096	1096				
Height	mm	818	920	1021	1275	1452	1452				
Compressor											
Type	Scroll	Scroll	Scroll	Scroll	Scroll	Scroll	Scroll				
Qty.	Ton	1/5	1/7,5	1/10	2x5	1/15	2x7,5	1/20	2x10	1/25 ou 2x12,5	
Condensing Coil											
Rows		2	2	2	2	2	2	2	2		
FPF (Fins perfoot)		228	216	216	216	216	204	204	204		
Fin Side Area	m ²	0,8	1,01	1,67	1,67	2,24	2,97	3,33	3,33		
Condensing Fan											
Quantity		1	1	1	1	2	1	1	1		
Propeller diameter	mm	22"	26"	30"	30"	26"	35"	35"	35"		
Air Flow	m ³ /h	7234	9180	11900	11900	18360	23800	30600	30600		
Pipe Diameters											
Number of Circuits		1	1	1	2	1	2	1	2	1	2
Liquid Line	in.	1/2"	1/2"	5/8"	1/2"	7/8"	1/2"	7/8"	5/8"	1.1/8"	5/8"
Suction Line	in.	7/8"	1.1/8"	1.3/8"	7/8"	1.3/8"	1.1/8"	1.5/8"	1.3/8"	2.1/8"	1.3/8"
Equipment Weight	kg	108	127	198	196	335	275	355	359	360	368

Tab. I-02 - General Data - Condensing Units TRCE 050 to 150

Model	050	075	100	150			
Nominal Cap.	Ton	5	7,5	10	15		
Dimensions							
Width	mm	993	1217	1491	1712		
Depth	mm	560	560	560	560		
Height	mm	1393	1494	1545	1849		
Compressor							
N° Circuits		1	1	1	2	1	2
Type	Scroll	Scroll	Scroll	Scroll	Scroll	Scroll	Scroll
Qty/Ton	Ton	1/5	1/7,5	1/10	2/5	1/15	2/7,5
Condensing Coil							
Rows		1	1	1	1		
FPF (Fin per Feet)	ft	276	276	276	276		
Fin Side Area	m ²	0,55	0,83	0,99	1,72		
Quantity		1	1	1	1		
Condensing Fan							
Motor	CV	1,5	3	4	5		
N° Phases		3	3	3	3		
Air Flow	m ³ /h	1,22	2,23	2 x 2,93	2 x 3,54		
Equipment Weight	kg	184	210	305	310	400	400

Note:
 (1) RLA = Rated Amps - 220V / 60 Hz.
 (2) FLA = Full Load Amps - 220V / 60 HZ
 (3) Voltage variation: +/- 10%

General Data

CRCB/CRCE

Tab. I-03 - General Data - Condensing Unit CRCE 050 to 150 for use w/ SIVE.

Model		050	075	100	125	150	
Nominal Cap. ⁽¹⁾	Ton	5	7,5	10	12,5	15	
Length	mm	993	1217	1491	1712	1712	
Depth	mm	560	560	560	560	560	
Height	mm	1393	1494	1545	1620	18 49	
Coil							
Rows		1	1				
FPF (Fins per foot)	ft	276	276	276	276	276	
Finned Face Area	m ²	0,55	0,83	0,99	1,39	1,72	
Fan Motor							
Quantity		1	1		1	1	
Motor	HP	1,5	3	4	4	5	
N° Phase		3	3	3	3	3	
Nominal Power	kW	1,17	2,18	2,83	2,83	3,46	
RLA ⁽³⁾	A	3,85	7,94	9,28	9,28	11,20	
FLA ⁽⁴⁾	A	4,81	9,93	11,60	11,60	14,00	
LRA ⁽⁵⁾	A	22,42	77,45	87,00	87,00	106,40	
Rotation/N° Poles	RPM	1700/4	1710/4	1720/4	1720/4	1730/4	
Air Flow	m ³ /h	5500	8250	99 50	13770	15750	
Pipe Diameters							
Number of Circuits		1	1	1	2	1	2
Liquid Line	in	1/2"	1/2"	5/8"	1/2"	5/8"	1/2"
Suction Line	in	7/8"	3/4"	7/8"	5/8"	1 1/8"	3/4"
Equipment Weight(3)	kg	148	170	233	236	276	278
							315
							320

Tab. I-04 - General Data - Remote Condensing Unit CRCB 100 to 150 for use w/ SIVE

Model		CRCB050	CRCB075	CRCB100	CRCB125	CRC B150
Nominal Cap. ⁽¹⁾	TR	5	7,5	10	12,5	15
Coil						
Rows		1	1	1	1	1
FPF (Fins per foot)		276	276	276	276	276
Finned type		Aletas de aluminio corrugadas				
Finned face area	m ²	0,54	0,83	0,99	1,38	1,72
Fan						
Quantity		1	1	2	2	2
Type		Centrifugo				
Diam. x Length	mm	321 x 321	321 x 321	270 x 270	321 x 321	321 x 321
Motor	CV	1	3	3	4	5
Air Flow	m ³ /h	5450	8315	9935	13930	17320
Dimensions - Remote Condenser - CRCB						
Length	mm	987	1241	1341	1646	1646
Depth	mm	631	631	631	714	714
Height	mm	890	890	941	1018	1247
Net Weight	kg	93	124	139	180	212

Note:

- (1) Data according to conditions in standard ARI 210.
- (2) Equipment weight refers to the Standard machine.
- (3) RLA = Rated Load Amps (A) - 220V/60Hz;
- (4) FLA = Full Load Amps (A) - 220V/60Hz;
- (5) LRA = Locked Rotor Amps (A) - 220V/60Hz.

II-Unit Inspection

Unit Inspection

Upon unit arrival at the location, proceed as follows:

- Make sure that the nameplate data matches Sales Order and delivery note data (including electrical ratings);
- Make sure the local power supply complies with nameplate ratings;
- Carefully inspect the unit looking for any sign of damage during transport. In case of any damage or lack of material, notify the carrier immediately. Specify the damage class and amplitude in the shipping/delivery note, before signing it;
- Report damages and actions to be taken for appropriate repair to Trane and/or the Contractor. The unit should only be repaired after damage inspection.

Storage

At delivery, if the unit cannot be placed in its permanent location, store it in a safe and weatherproof location and/or one that is not affected by other damage originators. Undue equipment storage and movement will result in void equipment warranty.

Instructions for proper installation

For proper installation, consider the following items before putting the unit into place:

- The engine room should have coherent lighting for service and/or maintenance.
- The unit floor or base must be leveled, solid and sufficiently resistant to support the weight of the unit and its accessories. Level or repair the floor where the unit is to be installed before putting it into place.
- Provide rubber grommets or vibration insulators for the units.
- Perform the hydraulic installation required to drain water from the condensate drip pan.
- Provide the recommended minimum clearances for routine maintenance and services (see page 22 of this manual).
- Consider the same clearances for multiple units together or condensing units.
- Perform the electric installation. Electric connection inlets are provided on both sides of the units.
- Provide enough clearances for accessing the piping and removing the covers.
- Power supply must comply with local and/or NEC codes.
- The contractor should provide and install the refrigerating piping - liquid line and suction line, in order to interconnect EU evaporating units and CU condensing units.

General Safety

TRAE and TRCE condensing units are designed for safe and reliable operation, whenever units are operated accordingly to safety norms.

The system operates with electric components, mechanical components, gas and water pressures, etc., which can result in damages to people and equipment, if required safety norms are not observed.

Thus, only installers who are accredited and/or authorized by Trane should perform installation, startup and maintenance in this equipment.

Follow all working safety norms and warnings in labels attached to the units. Always use appropriate equipment and tools.

Danger Identification



WARNING!

Warning are provided at appropriate intervals and places in this manual to indicate to operators and service personnel of potentially hazardous situations which MAY result in serious personal injuries or damage to the equipment, if safety norms are not observed.



CAUTION!

Caution are provided at appropriate intervals and places in this manual to indicate to operators and service personnel of potentially hazardous situations that may result in damages to equipment and/or to the environment.

III-Transport and Movement

Fig. III-01 - Instructions for transport and movement.

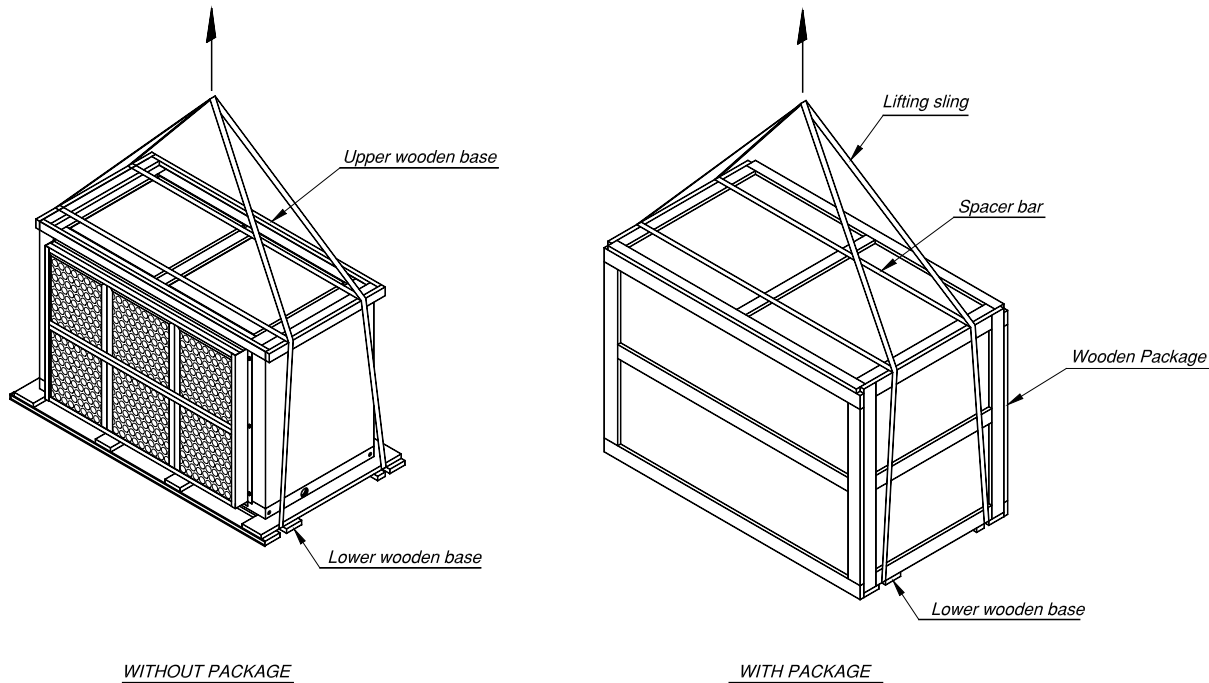

WARNING!

To avoid death or unit damage, equipment lifting capacity should exceed the unit weight and include an appropriate safety factor.



WARNING!

Each cable, belt or chain used to lift the unit should be able to support the total unit weight.

Instructions for handling and movement

For unit transport and movement, follow these instructions:

1. Check the actual equipment weight in the manual or on the nameplate.
2. For all units, place the cables or lifting chains under the wooden skid. Other lifting operations may cause equipment damages and serious personal injuries.
3. Avoid contact between steel cables, riggings or chains and the conditioner, preventing damages or accidents. Use adequate spacer bars, as shown in the drawing.
4. Do not remove module package until its placement in the permanent installation location. Be careful when moving the equipment.
5. During transport, do not swing the equipment more than 15° (fifteen degrees) in relation to its vertical position.
6. Always perform a lifting test to determine the exact stability and balance of the unit, before lifting it into the installation place.
7. For horizontal movement, use rollers of equal diameter under the wooden base.

IV-Refrigeration Piping (Interconnection)

TRAE/TRCE

Condenser Unit

To install remote condenser units, the following precautions must be taken:

- The condenser unit must be placed in a well ventilated area and comply with the clearance recommendations.
- The length of interconnection line between the evaporator unit and the condenser unit should be as short as possible;
- Do not reduce the line gauge;
- Avoid curves in the interconnection lines;
- Do not install the condenser unit in shafts or tunnels;
- The CU must be as close as possible to a horizontal line.
- Pipes must be soldered with silver or foscofer.
- Special care should be taken not to cause any type of obstruction in the pipes when soldering the lines. The interconnection pipes must not be dented. All soldering must be effected with nitrogen circulating inside the pipes to avoid carbonization
- When the interconnection lines are ready, pressure test the system at 200 psig to check for leaks.
- Evacuate the whole system - interconnection lines, evaporator and condenser units.
- Carry out the refrigerant charge.

Instructions for Fixing the Expansion Valve Thermostatic Bulb

- In the suction line, as closest as possible to the evaporator output.
- Before external equalization, in an horizontal line run.

- The copper tube must be completely clean.
- At the 12h position for pipes smaller than 7/8", and 4h or 8h position for 7/8" or larger pipes.
- Then insulate the pipes using thermal sheets.

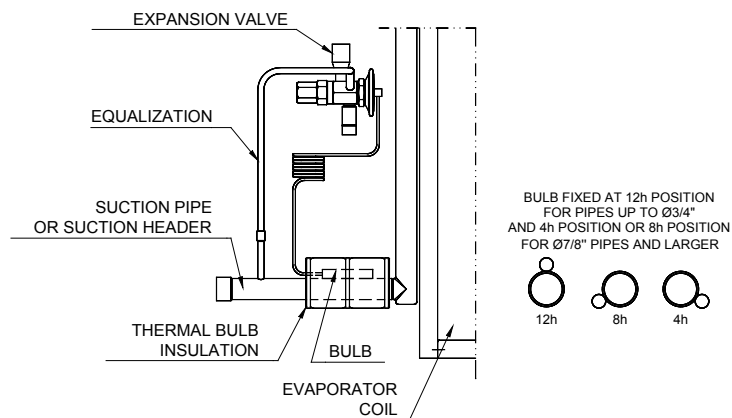

Tab. IV-01 - Tubing and connection gauges recommended by circuit

Line(Ton)	Connection Size (in.)		Equivalent Pipe Length													
	CXS Mod.		TRCE/TRAE		<12m		12~18m		18~24m		24~30m		30~36m		36~46m	
	Liq.	Suct.	Liq.	Suct.	Liq.	Suct.	Liq.	Suct.	Liq.	Suct.	Liq.	Suct.	Liq.	Suct.	Liq.	Suct.
5	1/2	7/8	1/2	7/8	1/2	7/8	1/2	7/8	1/2	7/8	1/2	1-1/8	5/8	1-1/8	5/8	1-1/8
7,5	5/8	1-1/8	1/2	1-1/8	1/2	7/8	1/2	1-1/8	5/8	1-1/8	5/8	1-1/8	5/8	1-1/8	7/8	1-3/8
10	5/8	1-3/8	5/8	1-3/8	5/8	1-1/8	5/8	1-1/8	5/8	1-1/8	7/8	1-3/8	7/8	1-3/8	7/8	1-3/8
12,5	5/8	1-3/8	5/8	1-3/8	5/8	1-1/8	7/8	1-3/8	5/8	1-5/8	7/8	1-5/8	7/8	1-5/8	7/8	1-5/8
15	5/8	1-5/8	7/8	1-3/8	5/8	1-3/8	7/8	1-3/8	7/8	1-3/8	7/8	1-5/8	7/8	1-5/8	7/8	1-5/8
20	5/8	1-5/8	1 1/8	1-5/8	7/8	1-3/8	7/8	1-5/8	7/8	1-5/8	7/8	1-5/8	7/8	1-5/8	1-1/8	2-1/8
25	7/8	2-1/8	1 1/8	1-5/8	7/8	1-3/8	7/8	1-5/8	7/8	1-5/8	1-1/8	2-1/8	1-1/8	2-1/8	1-1/8	2-1/8

Note: For equivalent lengths above the values indicated, please contact Trane or an authorized installer.

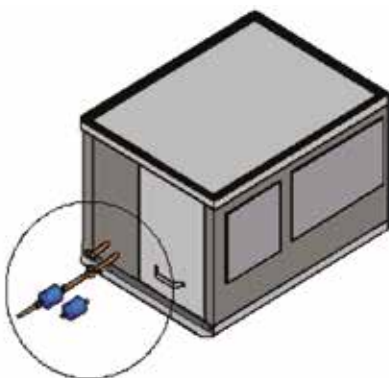

MOUNTING DIAGRAM DRIER FILTER

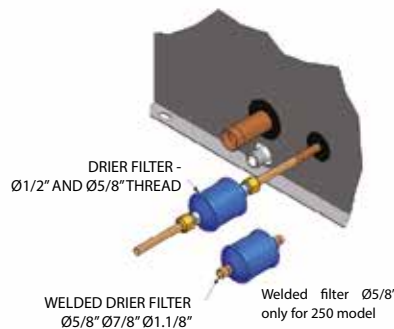

MOUNTING DIAGRAM DRIER FILTER AND LIQUID SIGHT GLASS

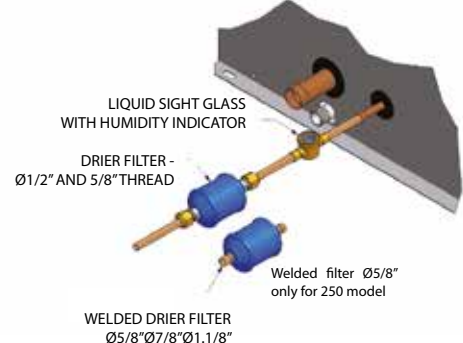

Refrigerating Tubing - Interconnection

TRAE/TRCE

Refrigerant Piping

Units should be interconnected with copper pipes.

Connection gauges of evaporating units and remote condensing units TRAE or TRCE, and suction and liquid piping gauges recommended for interconnecting both are indicated on Table IV-01.

The corresponding lengths already include losses generated by valves, curves, elbows, reductions, etc.

Maximum distance (recommended)*

distance between units: **46 m**.

difference in levels between units: **18 m**.

(*) – Calculated distance, considering equivalent length of connection elements.

For distances higher than the recommended value, please contact **Trane**.

Evaporating Unit above the Condensing Unit

- Build a 20 cm inverted siphon in the suction line at the evaporating unit outlet, after the regular oil accumulation siphon.
- Horizontal sections in the suction line should be inclined by 45 mm at every 10 m of line towards condensing unit.

Condensing Unit above the Evaporating Unit

- Build a 10 cm siphon at rising and a siphon at every 7.5 m of vertical line.
- Horizontal sections in the suction line should be inclined by 45 mm at every 10 m of line towards condensing unit.

Fig. IV-01 - Assembly Evaporating Unit over Condensing Unit.

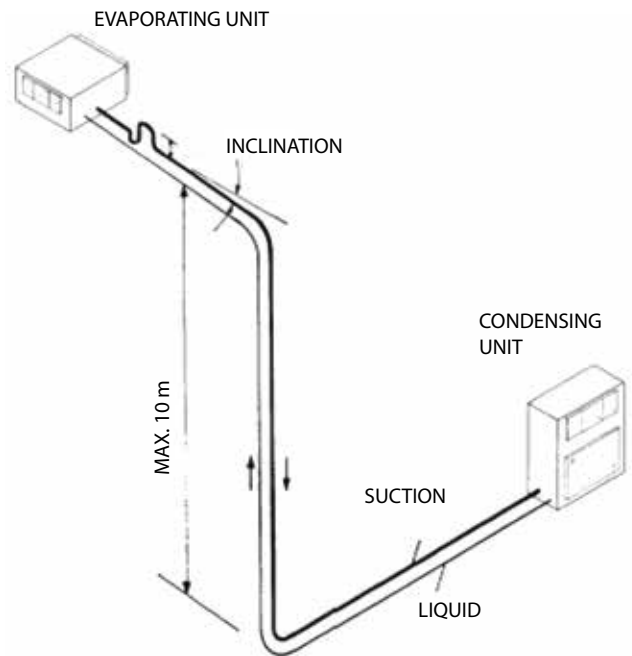
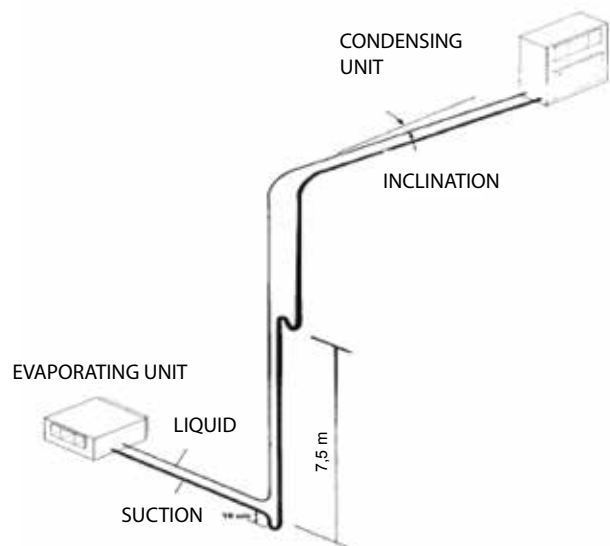

Fig. IV-02 - Assembly Condensing Unit over Evaporating Unit.



Refrigerating Tubing - Interconnection

TRAE/TRCE

Condensing Unit at the same level as Evaporating Unit (fig. on the right)

- Build a 20 cm inverted siphon in the suction line at the evaporating unit outlet, after the regular oil accumulation siphon.
- Horizontal sections in the suction line should be inclined by 45 mm at every 10 m of line towards condensing unit.

Nominal Load of Refrigerant R410A

The nominal load of refrigerant R410A and oil for the units is indicated in Table 04.

The refrigerant in the piping that should be added is not considered in these loads. When the distance between the evaporating unit and the condensing unit is **more than 5 meters**, it is necessary to complement the refrigerant load. The calculation is based on Table 05.

The refrigerant load will only be correct when superheat and subcooling range is 8°C to 12°C and 5°C to 10°C, respectively. See Table VI - 03 on page 14 of this manual.

Nominal Oil Load

In installations where the actual length is higher than 20 m, add 0.10 liters of oil for each kg of refrigerant added due to tubing.

Note: The oil used is Trane OIL00080 (except for TRAE/TRCE050 and TRAE/TRCE100 2 circuits which use OIL00068P).

Fig.IV-03 - Assembly diagram for EU at the same level as CU

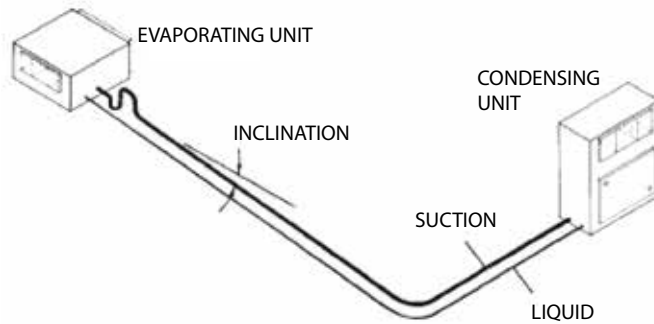

Tab. IV-04 - Nominal load of refrigerant R410a and oil load - Condensing Units + Onix

Indoor	Outdoor	R410a(kg)		Oil(L)	
		Ckt1	Ckt2	Ckt1	Ckt2
CXPA050 1C	TRAE050 1C	2,99		1,57	
CXPA075 1C	TRAE075 1C	3,40		3	
CXPA100 1C	TRAE100 1C	5,95		3,3	
CXPA100 2C	TRAE100 2C	2,99	2,99	1,57	1,57
CXPA125 2C	TRAE 075 + TRAE 050	4,59	2,99	3	1,57
CXPA150 1C	TRAE150 1C	8,76		3,6	
CXPA150 2C	TRAE150 2C	4,59	4,59	3	3
CXPA200 1C	TRAE200 1C	10,46		6,7	
CXPA200 2C	TRAE200 2C	7,07	7,07	3,3	3,3
CXPA250 1C	TRAE250 1C	13,01		6,7	
CXPA250 2C	TRAE250 2C	7,07	7,07	3,3	3,3
CXPA300 2C	TRAE150 1C + TRAE150 1C	8,76	8,76	3,6	3,6
CXPA350 2C	TRAE200 1C + TRAE150 1C	10,46	8,76	6,7	3,6
CXPA400 2C	TRAE200 1C + TRAE200 1C	10,46	10,46	6,7	6,7
CXPA500 2C	TRAE250 1C + TRAE250 1C	13,01	13,01	6,7	6,7
CXPA050 1C	TRCE050 1C	1,36		1,57	
CXPA075 1C	TRCE075 1C	2,08		3	
CXPA100 1C	TRCE100 1C	2,72		3,3	
CXPA100 2C	TRCE100 2C	1,36	1,36	1,57	1,57
CXPA125 2C	TRCE 075 + TRCE 050	2,08	1,36	3	1,57
CXPA150 1C	TRCE150 1C	4,17		3,6	
CXPA150 2C	TRCE150 2C	2,08	2,08	3	3
CXPA200 2C	TRCE100 1C + TRCE100 1C	2,72	2,72	3,3	3,3
CXPA250 2C	TRCE150 1C + TRCE100 1C	4,17	2,72	3,6	3
CXPA300 2C	TRCE150 1C + TRCE150 1C	4,17	4,17	3,6	3,6

Refrigerating Tubing - Interconnection

Tab. IV-05 - Nominal Load of R410a Refrigerant and Oil - Condensing Units + Solution Plus

Model	R410a Refrigerant (kg)	Oil Inicial Load (liters)
5	3,27	1,57
7,5	3,71	3,0
10	6,50	3,3
10	3.27+3.27	1.57+1.57
12,5	3.27+5.01	1.57+3.0
15	5.01+5.01	3.0+3.0
20	7.72+7.72	3.3+3.3
25	7.72+9.56	3.3+3.3
30	9.56+9.56	3.6+3.6
35	9.56+11.42	6.7+3.6
40	11.42+11.42	6.7+6.7
50	14.2+14.2	6.7+6.7

Tab. IV-06 - Additional load of refrigerant R410a.

Diameter	Suc Line (kg/m)	Liquid Line (kg/m)
1/2"	0,004	0,120
5/8"	0,007	0,187
3/4"	0,010	0,269
7/8"	0,013	0,366
1 1/8"	0,022	0,606
1 3/8"	0,033	
1 5/8"	0,046	

Refrigerating Tubing - Interconnection

CRCB/CRCE

Recommendations for refrigerating and accessories installation

Condenser Unit above Evaporator Unit

a. Put a trap in the riser base of the discharge line. If the vertical riser exceeds 7,5 m, put an additional trap in each 7,5 m. Install it at the middle of the piping. Make an inverse trap next to the condenser, according to figure above.

b. In the horizontal sections of the discharge line, put a 45 mm inclination in the direction of the flow of refrigerant each 10 meters.

Evaporator Unit above Condenser Unit and at the Same Level

In these cases, it is not necessary to make traps; it is enough to put a 45 mm inclination in the horizontal sections in the direction of the flow, each 10 m.

Figure IV-06 - Recommendations For Refrigerating Instalation. Condenser Unit above Evaporator Unit

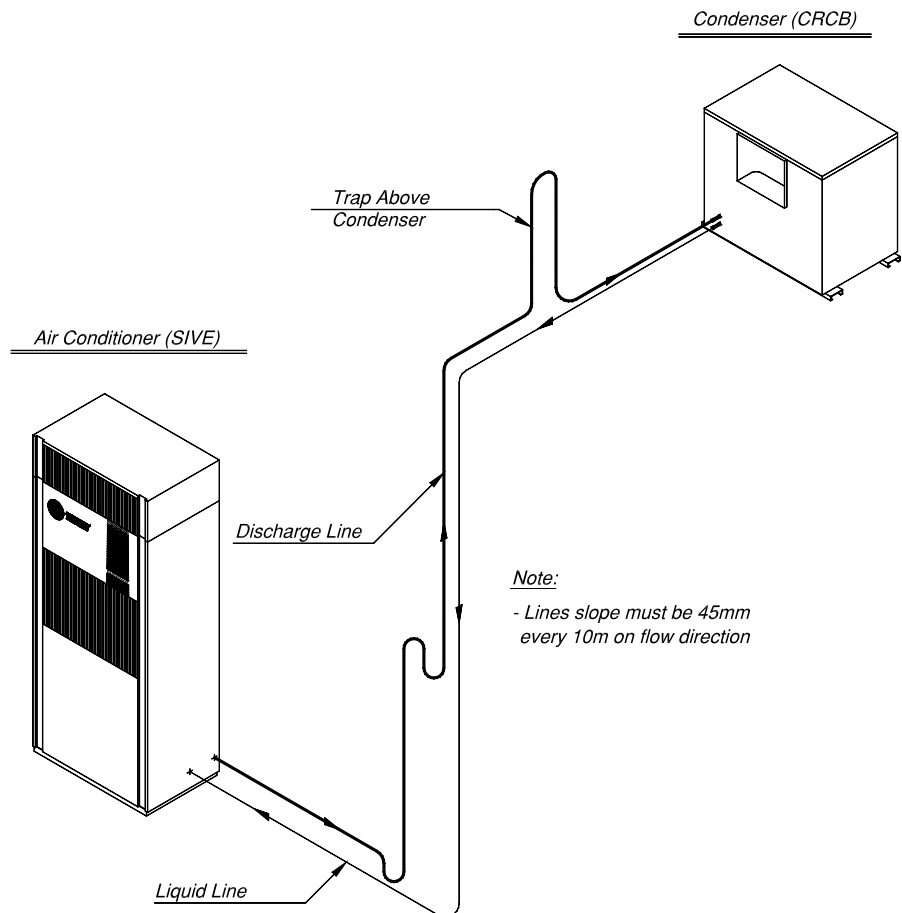

V-Periodic Preventive Maintenance

Preventive Maintenance

IMPORTANT

Perform all inspections and maintenance services at recommended intervals. This will extend the equipment life and reduce the possibility of equipment failure.

Operational conditions of this unit should be logged monthly. The operational data sheet can be a valuable tool for technical support personnel during diagnosis. By noting operational condition trends, the operator can often foresee and avoid problems before they become serious. If the unit is not operating properly, please refer to the irregularity analysis section, at the end of this manual.

Weekly Maintenance

After the equipment has been running for approximately 30 minutes and the system is stable, check the operation conditions and follow these checking procedures:

- Clean permanent air filters regularly, according to the installation site.

Monthly Maintenance

- Clean permanent air filters. Replace throwaway filters.
- Check fan belts for tension, alignment and wear.
- Clean the fan volutes.
- Tighten all terminal bolts.
- Clean the evaporator pan, the drain hose and the condensed water drain.

- Check the liquid line sight glass. Test against leakages and repair them, if required.
- If operational conditions and liquid sight glass indicate lack of gas, measure the system superheat and subcooling. Please refer to "System Superheat" and "System Subcooling" sections.
- If operational conditions indicate overcharge, slowly remove refrigerant through the service Schrader valve of the liquid line.
- Inspect the system to detect abnormal conditions. Use the log sheet to register unit conditions. A comprehensive log sheet is a valuable tool for technical support personnel.

Quarterly Maintenance

- Perform all monthly maintenance services.
- Check sheave and bearing fastening bolts. Adjust them, if necessary.
- Clean the condenser, according to the installation site.
- Clean the evaporator, according to the installation site.
- Check and note down service voltages and currents of fan and compressor motors.
- Test the safety controls.
- Check and note down wet bulb and dry bulb temperatures at evaporator inlet and outlet.
- Check suction and discharge pressure using a manifold gauge.
- Measure and register the system superheat.
- Measure and register the system subcooling.

Annual Maintenance

- Perform all recommended quarterly and monthly maintenance services.
- Ask a qualified technician to verify the adjustment and operation of each control, and also inspect and replace contactors or controls, if necessary.
- Remove cabinet panels and eliminate rust points.
- Replace defective thermal insulation and hardware.
- Touch up internal and external paintings, if required.
- Eliminate oxidation.
- Inspect the condenser pipes and clean them, if required.
- Inspect the expansion valve bulb for cleaning. Clean it, if required. The contact between the bulb and the suction line must be excellent and adequately isolated.
- Measure the compressor motor electric insulation.

IMPORTANT

If equipment preventive maintenance is not performed, this may result in loss of performance and the equipment warranty can even become void.

Corrective Maintenance

Compressor Installation

The compressor may have problems mainly at two levels: mechanical or electric. In both cases, the compressor must be replaced, but keep in mind that this replacement is not enough. It is always important to locate and eliminate the cause(s) of the failure(s).

Mechanic Breakdown

If the compressor has no service valves, transfer the refrigerant to an appropriate cylinder, perform a pressurization test (maximum 200 psig to protect low pressure regulator), make new vacuum, refrigerant load and new start with all readings. Correct the installation to solve any problems that have affected the equipment, releasing it to normal operation and always perform follow-up using the services of a qualified company. In case the compressor has service valves, the refrigerant can remain in the circuit.

- 1.1. Turn the compressor electric circuitry off and remove electric cables (mark them);
- 1.2. Close compressor suction and discharge valves;
- 1.3. Remove the welding in the connections of the compressor to suction and discharge pipes;
- 1.4. Remove the compressor;
- 1.5. Install the new compressor
- 1.6. Install the electric circuitry and pressure regulator tails;
- 1.7. Evacuate the compressor;
- 1.8. Open compressor valves.

Motor Burnout

The motor burnout results in the production of acids and deposition of oxides and sludge in parts of the circuitry. Thus, it is necessary to replace the refrigerant and the oil, as well as to clean all circuit and place HH antiacid dryer filters in liquid and

suction lines. In this case, cleaning should proceed as follows:

- 2.1. Collect all refrigerant in a cylinder and send it to the manufacturer for recycling, or recycle it using appropriate equipment.

 **WARNING!**

Never release gas into the environment; always use appropriate equipment.

- 2.2. Remove the compressor;
- 2.3. Remove the dryer filter;
- 2.4. Install the adequate filter in the compressor suction line and replace the one in the liquid line;
- 2.5. Install the new or recovered compressor, evacuate and load the system;
- 2.6. Check contactors for cleanliness. If required, replace them;
- 2.7. Start the equipment and observe its operation;
- 2.8. Verify pressure loss through the suction filter. If it exceeds the manufacturer-recommended value, replace the filter;
- 2.9. After 24-hour operation, analyze oil;
- 2.10. Change oil and filters every 48 hours until oil is free of acidity;
- 2.11. Remove the suction filter.

When cleaning a circuit with two compressors, replace burnout compressor oil and its pair.

Leakage tests with nitrogen

The leakage test should be performed after the installation of interconnection tubing of separated units, whenever the liquid sight glass shows bubbling or after repairs in the equipment refrigerating circuit.

Use refrigerant as a test element to detect leakage and dry nitrogen to achieve the test pressure.

Evacuation

- Evacuation is required to remove water steam and non-condensable gases from the system;
- Use rotary style high vacuum pump;
- Install the set manometer-manifold.
- A vacuum of at least one hour is recommended to perform the first reading. The evacuation is only completed when the final vacuum is between 250 and 500 microns. As a release test, the pump register should be closed for 5 minutes and the vacuum should not exceed 100 microns.

 **WARNING!**

Always use pressure regulator valve in the dry nitrogen cylinder to test leakage. If this valve is not used, there may be fatal consequences due to explosion.

 **WARNING!**

Under no circumstances use oxygen or acetylene instead of dry nitrogen to test leakage. Undue use of such gases may have fatal consequences, as explosions, chemical reactions or other reactions can occur.

IMPORTANT

The follow-up of a perfect evacuation must be performed using proper equipment, and never measured in relation to evacuation time, but in reference to negative pressure: 250 to 500 microns.

VI-Operational and Electric Features

Tab. V-01 - Compressor Electrical Characteristics - 60 Hz

Nominal Capacity	Kw (Nominal)	Kw (Maximum)	RLA			FLA			LRA		
	220V / 380V / 440V	220V / 380V / 440V	220	380	440	220	380	440	220	380	440
5	5,7	7,18	16,8	11,0	7,9	20,5	13,2	9,5	170,0	96,0	82,0
7,5	8,57	10,83	26,2	16,3	13,2	31,6	19,7	15,9	203,0	124,0	98,0
10	9,96	12,51	31,3	19,0	15,3	37,5	22,8	18,3	267,0	160,0	142,0
12,5	12,94	16,22	38,8	23,8	19,0	46,8	28,8	22,9	304,0	168,0	147,0
15	16,45	20,45	50,0	29,8	25,0	59,8	35,7	29,9	351,0	239,0	197,0
20	22,56	28,18	74,6	40,9	31,2	86,5	49,5	38,6	485,0	260,0	215,0
25	27,21	34,29	81,3	48,7	39,2	98,7	59,6	48,0	560,0	310,0	260,0

Notes:

- (1) RLA = Rated Load Amps (A)
- (2) FLA = Full Load Amps (A)
- (3) LRA = Locked Rotor Amps (A)

Tab. VI-02 - Motors and Condensers Electrical Characteristics - TRAE (60 Hz)

Motors Capacity (cv)	Single-phase - IP21			CNO			CMO			CRT		
	N. Polos	rpm	kW	220		440	220		440	220		440
0,25	8	800	0,18	1,8	-	-	1,79	-	-	3,4	-	-
0,75	8	800	0,55	4,3	-	2	4,3	-	2	12,9	-	6
1	8	800	0,75	4,9	-	2,4	4,9	-	2,4	14,20	-	6,70

Tab. V-03 - Normal operational conditions

1. High Pressure	329 a 548 psig
2. Low Pressure	124 a 134 psig
3. Overheating	5.5°C ~ 11°C
4. Subcooling	5°C ~ 10°C
5. Liquid Sight Glass	Refrigerant flow with no traces of gas
6. Voltage (V)	Must not exceed +/- 10% of nameplate voltage
7. Current (A)	Must not exceed the nameplate current



WARNING!

Never connect a jumper to protection and safety devices, so as to avoid damages to motors and compressors, as well as to preserve the physical integrity of operators and maintenance personnel.

Tab. V-04 - Control Adjustment

Control	Cutout	Reset	Notes
High Pressure Regulator	625 +/- 17 psig	465 +/- 30 psig	Air Condensation
Low Pressure Regulator	50 +/- 7 psig	45 +/- 17 psig	For both
Motor Coil Thermostat	105°C	82°C	For both

Notes:

- (1) Subcooling measure must be done on saturated liquid data.
- (2) Overheating must be done on saturated heat data.

VII-Wiring Diagram

Fig. VII-01 - Wiring Diagram - TRAE050

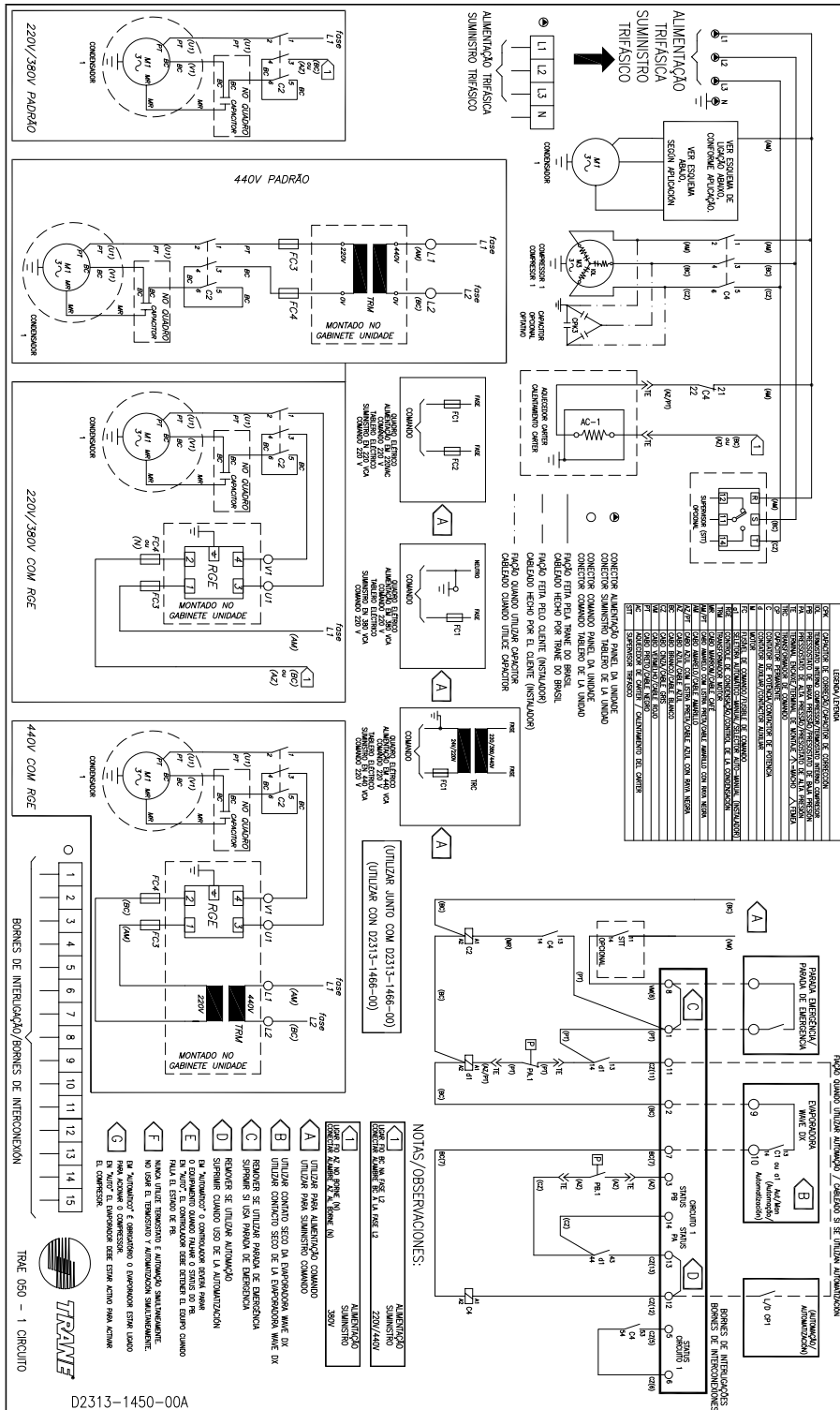

Wiring Diagram

Fig. VII-02 - Wiring Diagram - TRAE075/TRAE100 with 1 Circuit/TRAE150 with 1 Circuit

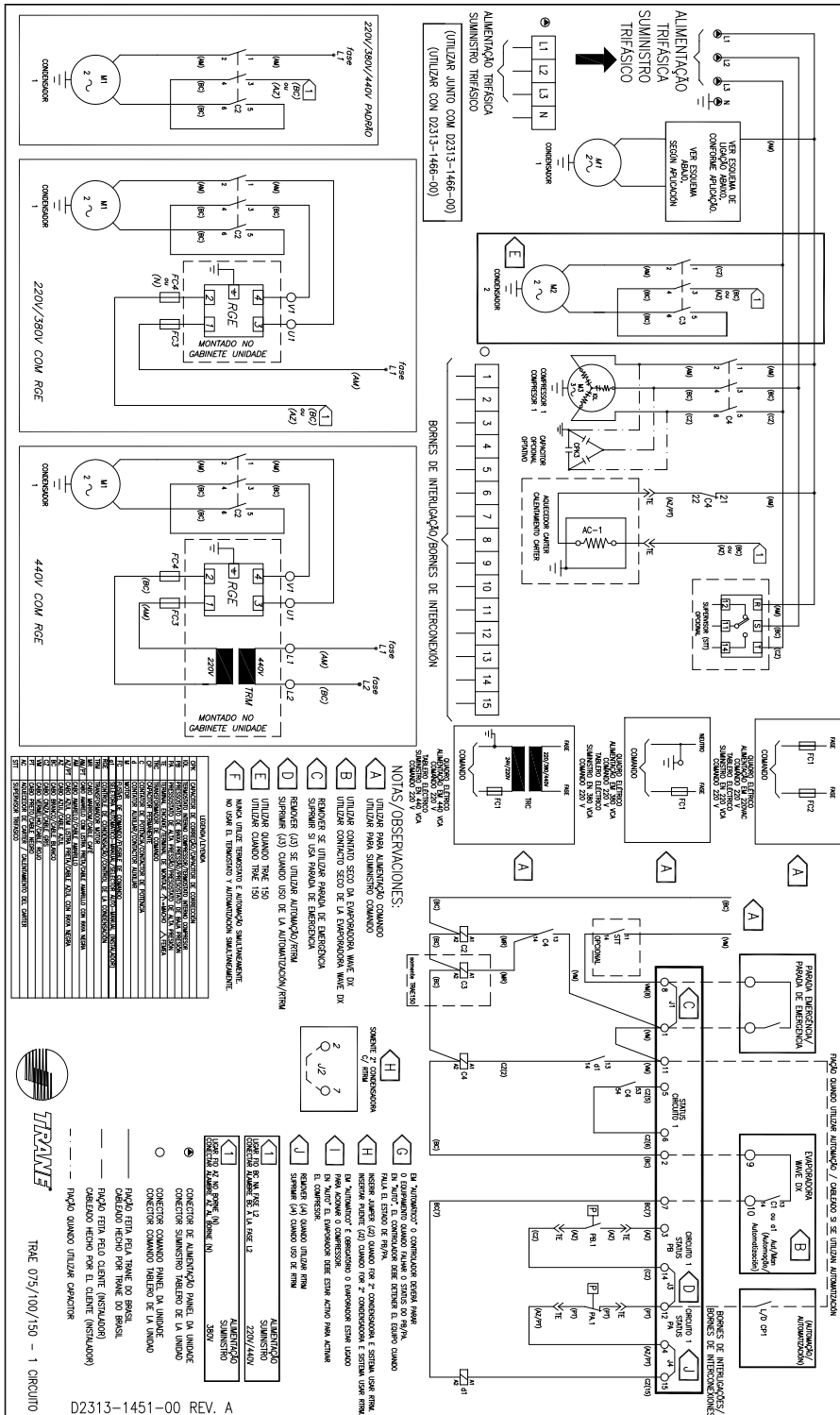

Wiring Diagram

Fig. VII-06 - Wiring Diagram - TRAE050/TRAE075; TRAE100/TRAE150 with 2 Circuits (RTRM Option)

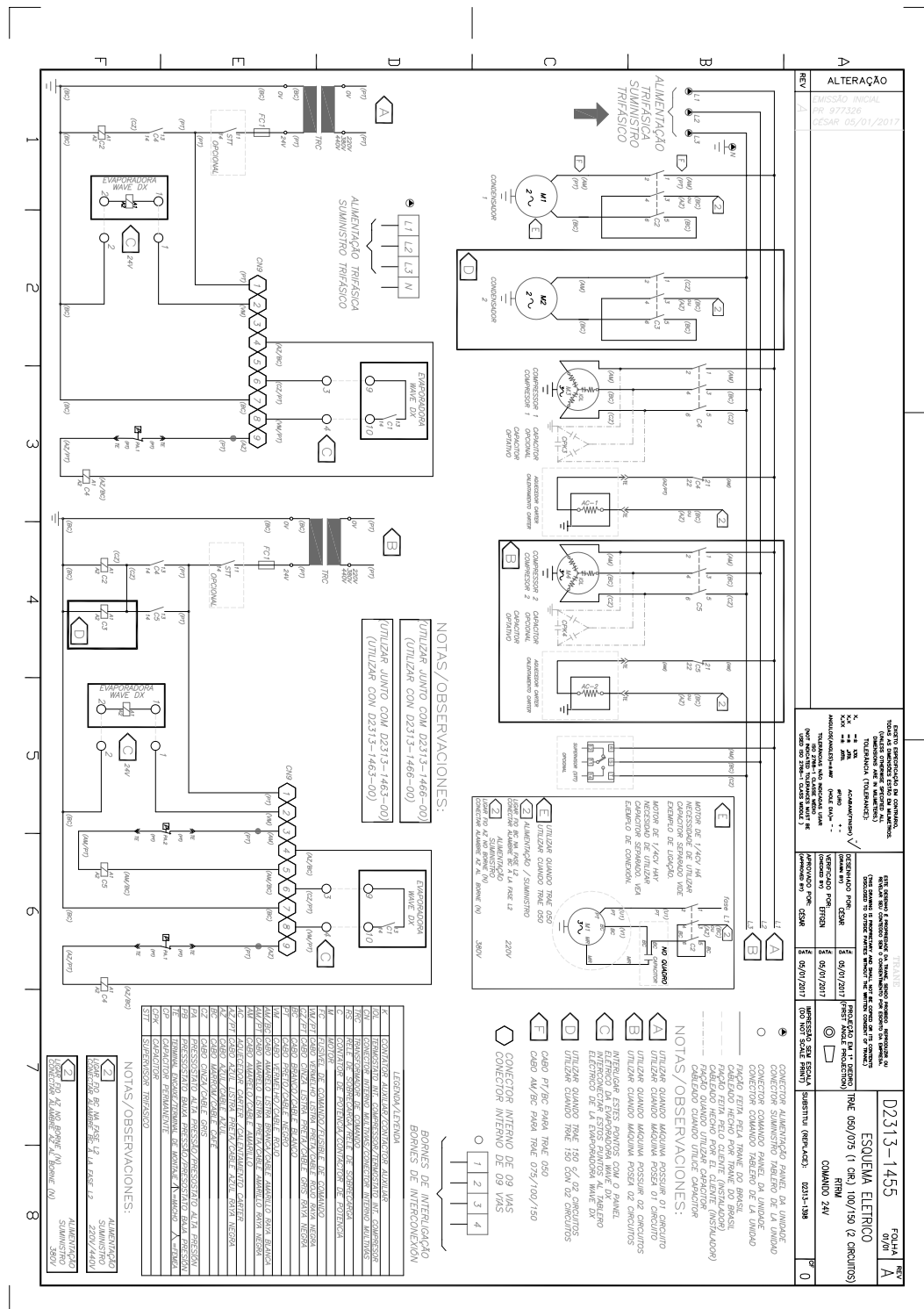

Wiring Diagram

Fig. VII-09b - Wiring Diagram - TRAE200/TRAE250 with 1 Circuit (RTRM Option)

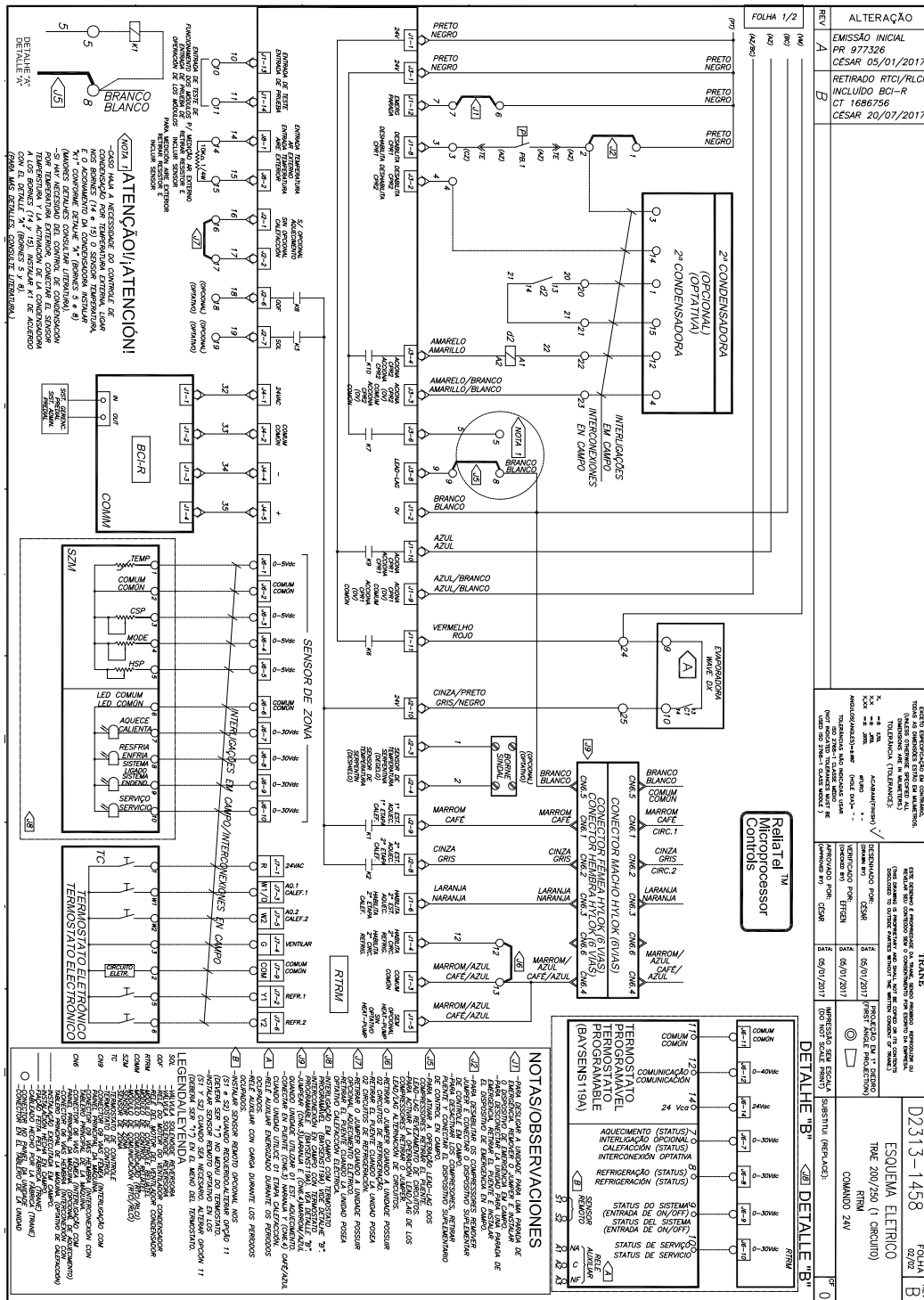

REV	ALTERACIÓN	FECHA
A	EMISSÃO INICIAL PR 977326 CESAR 05/01/2017	05/01/2017
B	RETIRADO RTC/RLCI INCLUIDO BCI-R CT 1686756 CESAR 20/07/2017	20/07/2017

DATA	APROBADO POR	DESIGNADO POR
05/01/2017	CESAR	CESAR
20/07/2017	CESAR	CESAR

DATA	APROBADO POR	DESIGNADO POR
05/01/2017	CESAR	CESAR
20/07/2017	CESAR	CESAR

DATA	APROBADO POR	DESIGNADO POR
05/01/2017	CESAR	CESAR
20/07/2017	CESAR	CESAR

Wiring Diagram

Fig. VII-10a - Wiring Diagram - TRAE200/TRAE250 with 2 Circuits (RTRM Option)

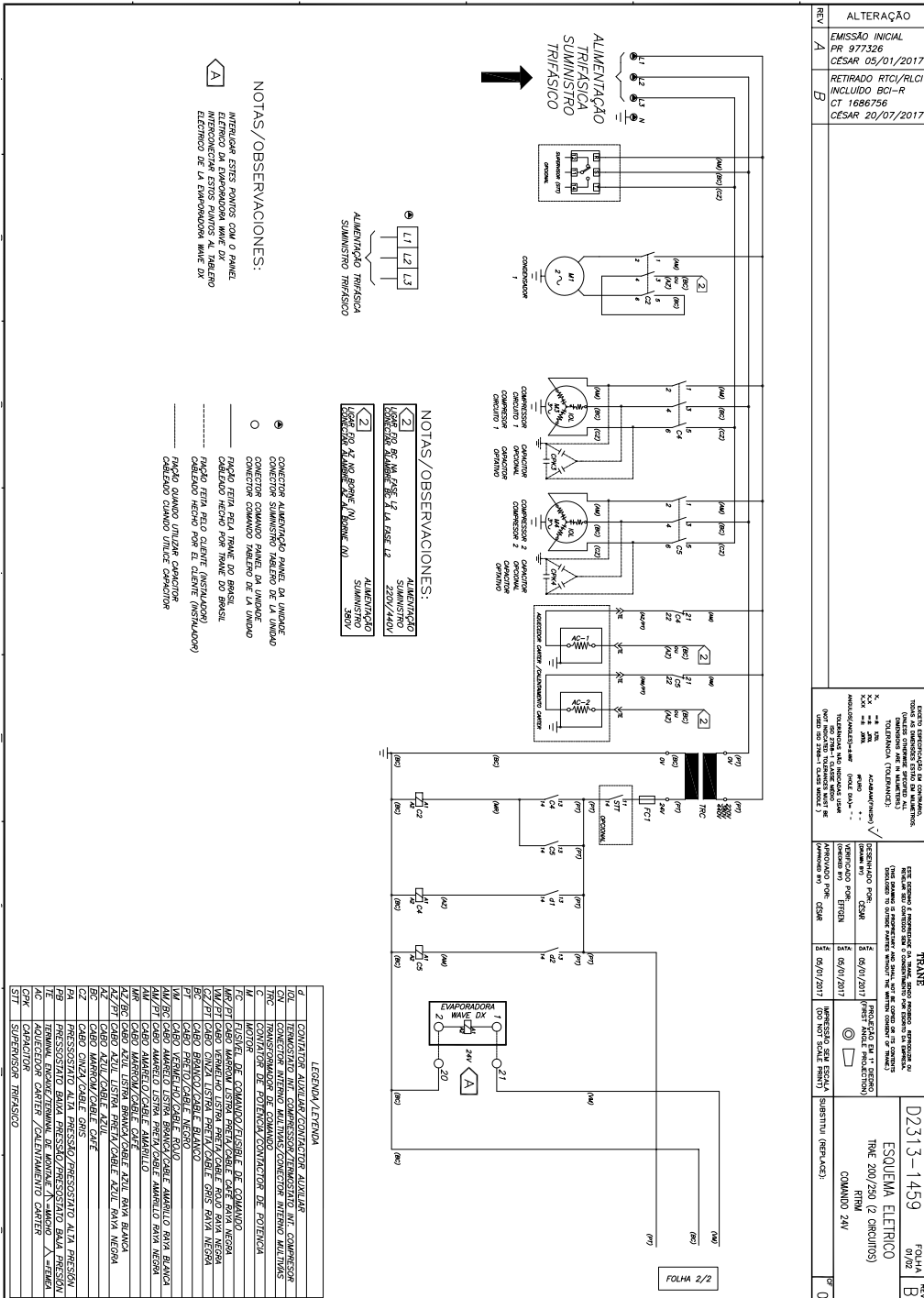

REV	ALTERAÇÃO	PR	977326	CE	05/01/2017	RE	1686756	CE	20/07/2017
A	EMIÇÃO INICIAL								
B	RETIRADO RTCI/RLCI INCLUIDO BCI-R								
<p>Este documento é propriedade da TRANE. Não é permitida a reprodução ou a utilização sem a autorização da TRANE. A TRANE não se responsabiliza por danos ou prejuízos decorrentes do uso indevido deste documento.</p> <p>TRANE ESQUIVA, ELÉTRICO TRAE 200/250 (2 CIRCUITOS) COMANDO 2AV</p>									
<p>FOFHA 01/02 D2313-1459</p>									
<p>Substitui (replace):</p>									
<p>0</p>									

Wiring Diagram

Fig. VII-16 - Wiring Diagram - TRCE050/TRCE075; TRCE100/TRCE150 with 2 Circuits (RTRM)

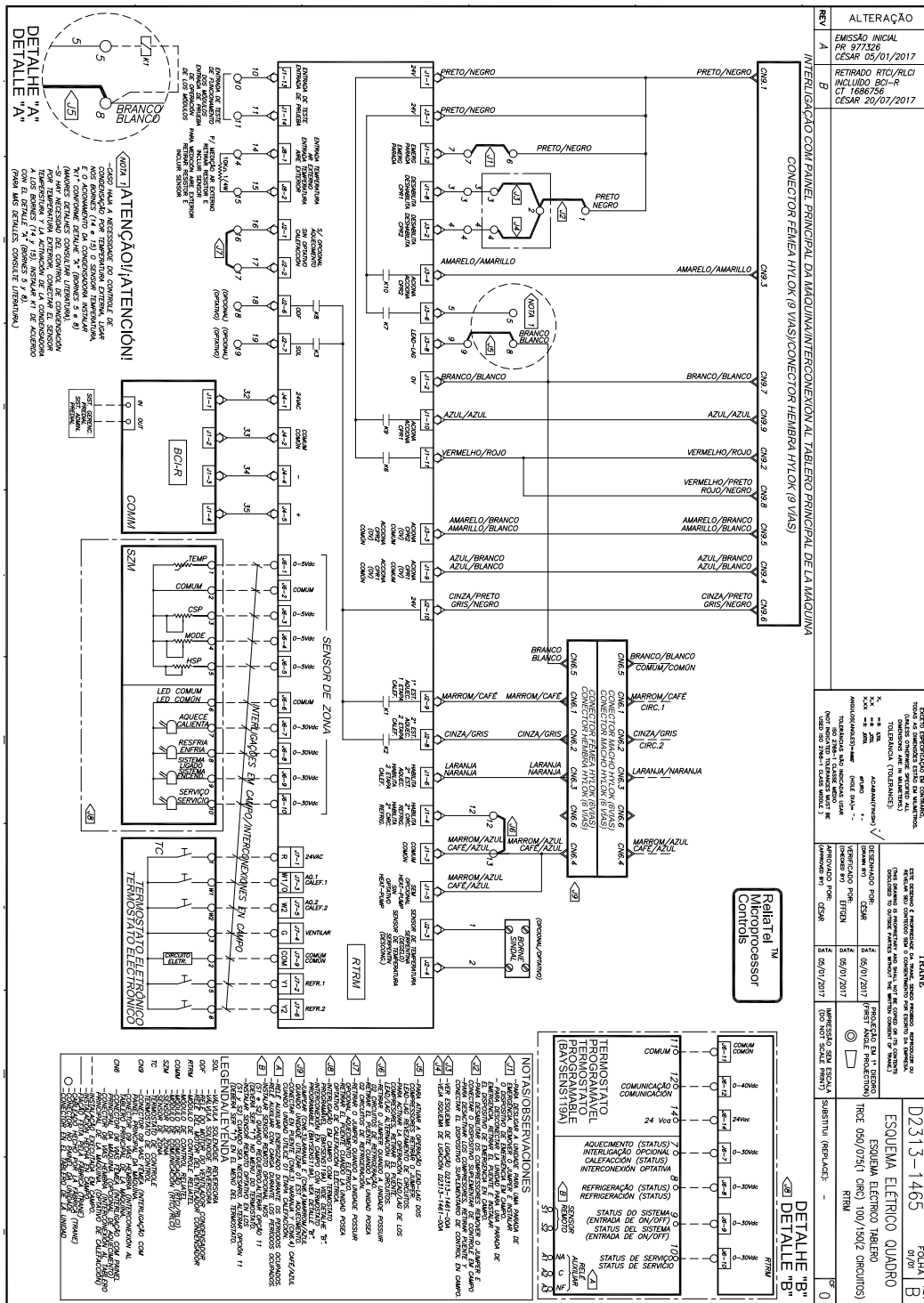

VIII-Control Panel Lay Out

Fig. VII-18 - Control Panel Lay Out - TRAE (Standard)

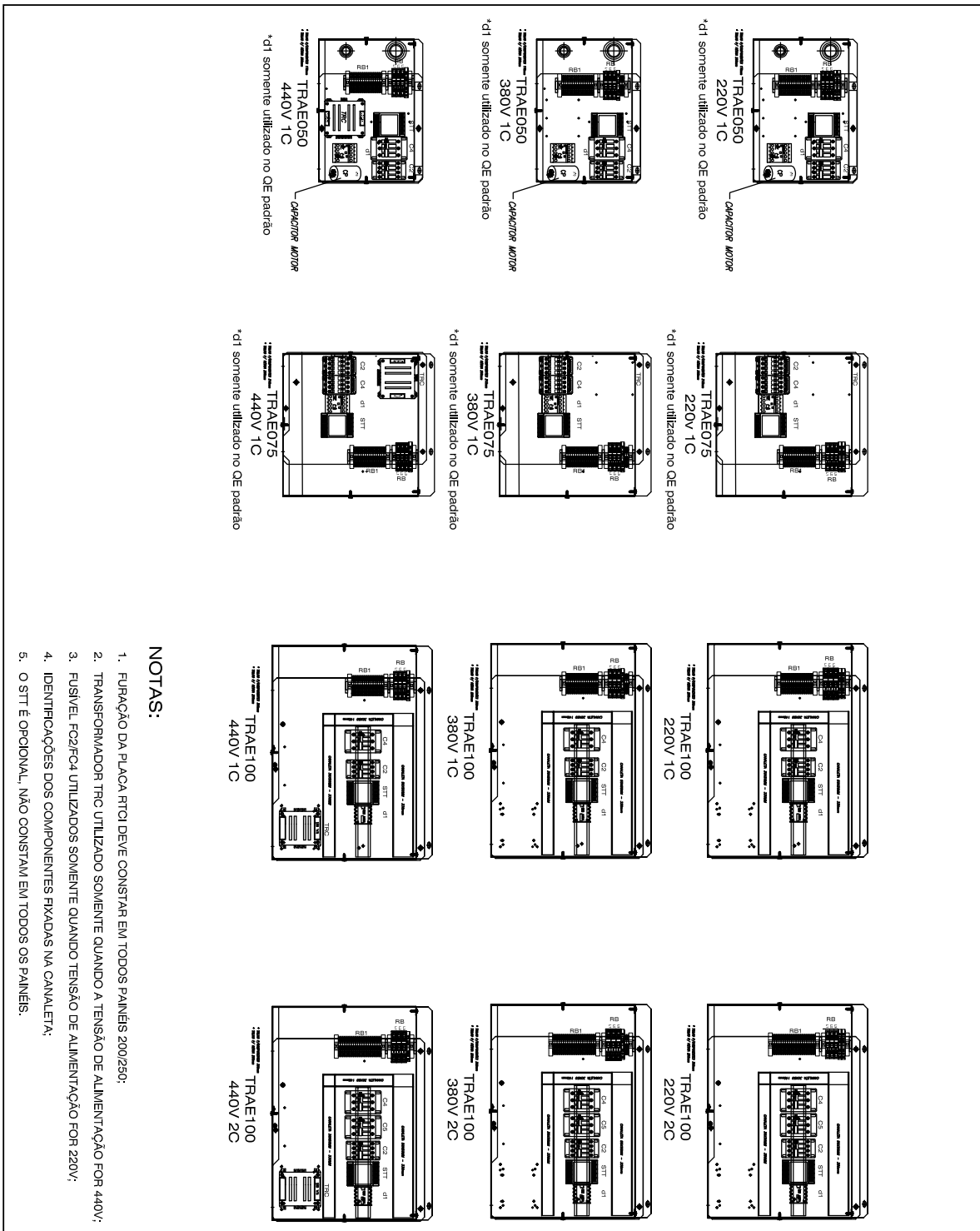

NOTAS:

1. FURAÇÃO DA PLACA RTCI DEVE CONSTAR EM TODOS PAINÉIS 200/250.
2. TRANSFORMADOR TRC UTILIZADO SOMENTE QUANDO A TENSÃO DE ALIMENTAÇÃO FOR 440V.
3. FUSÍVEL F02/F04 UTILIZADOS SOMENTE QUANDO TENSÃO DE ALIMENTAÇÃO FOR 220V.
4. IDENTIFICAÇÕES DOS COMPONENTES FIXADAS NA CANALETA.
5. O STT É OPCIONAL, NÃO CONSTAM EM TODOS OS PAINÉIS.

Control Panel Lay Out

TRAE

Fig. VII-19 - Control Panel Lay Out - TRAE (Standard)

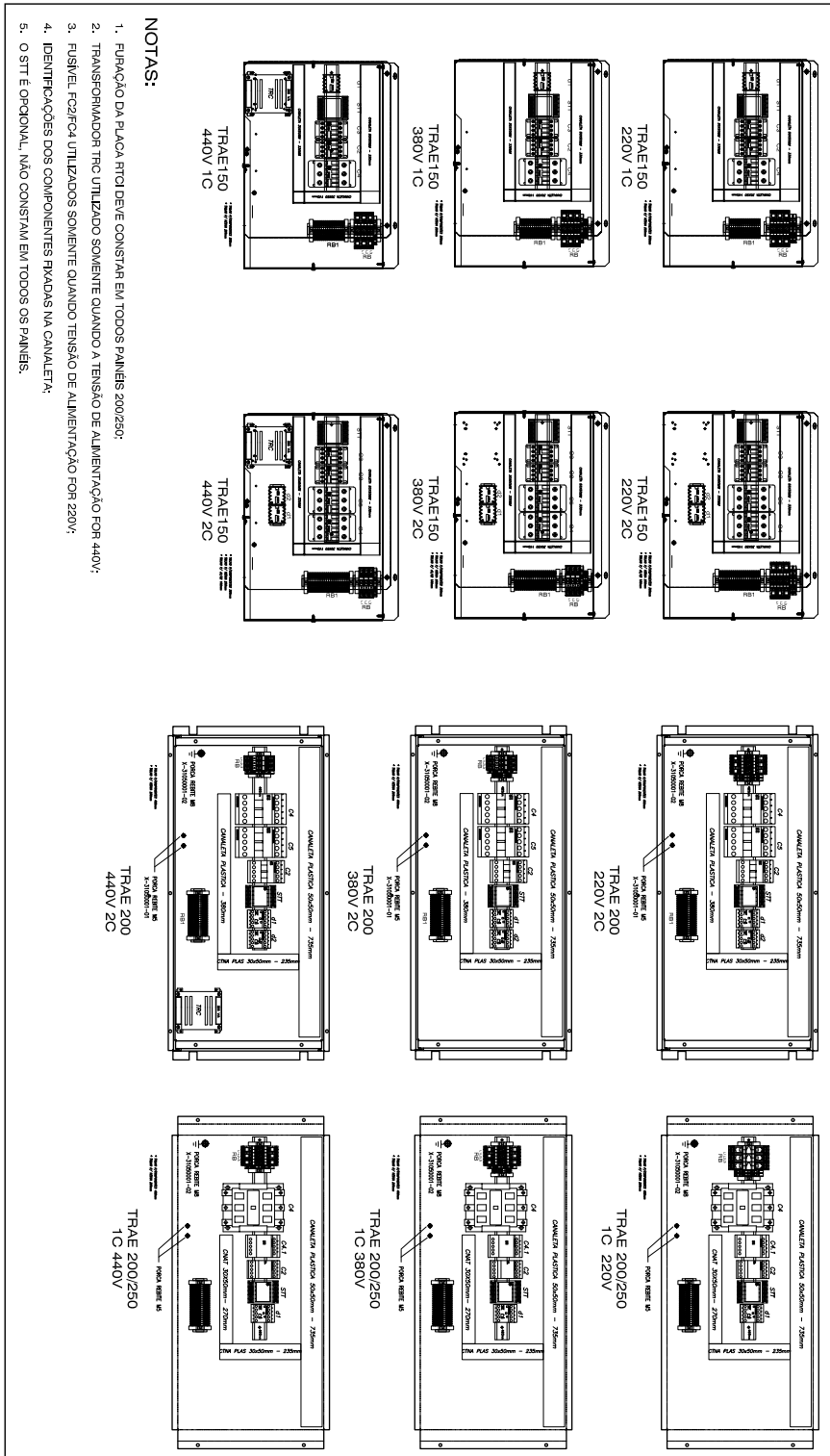

Control Panel Lay Out

TRAE-RTRM

Fig. VII-20- Control Panel Lay Out - TRAE (RTRM)

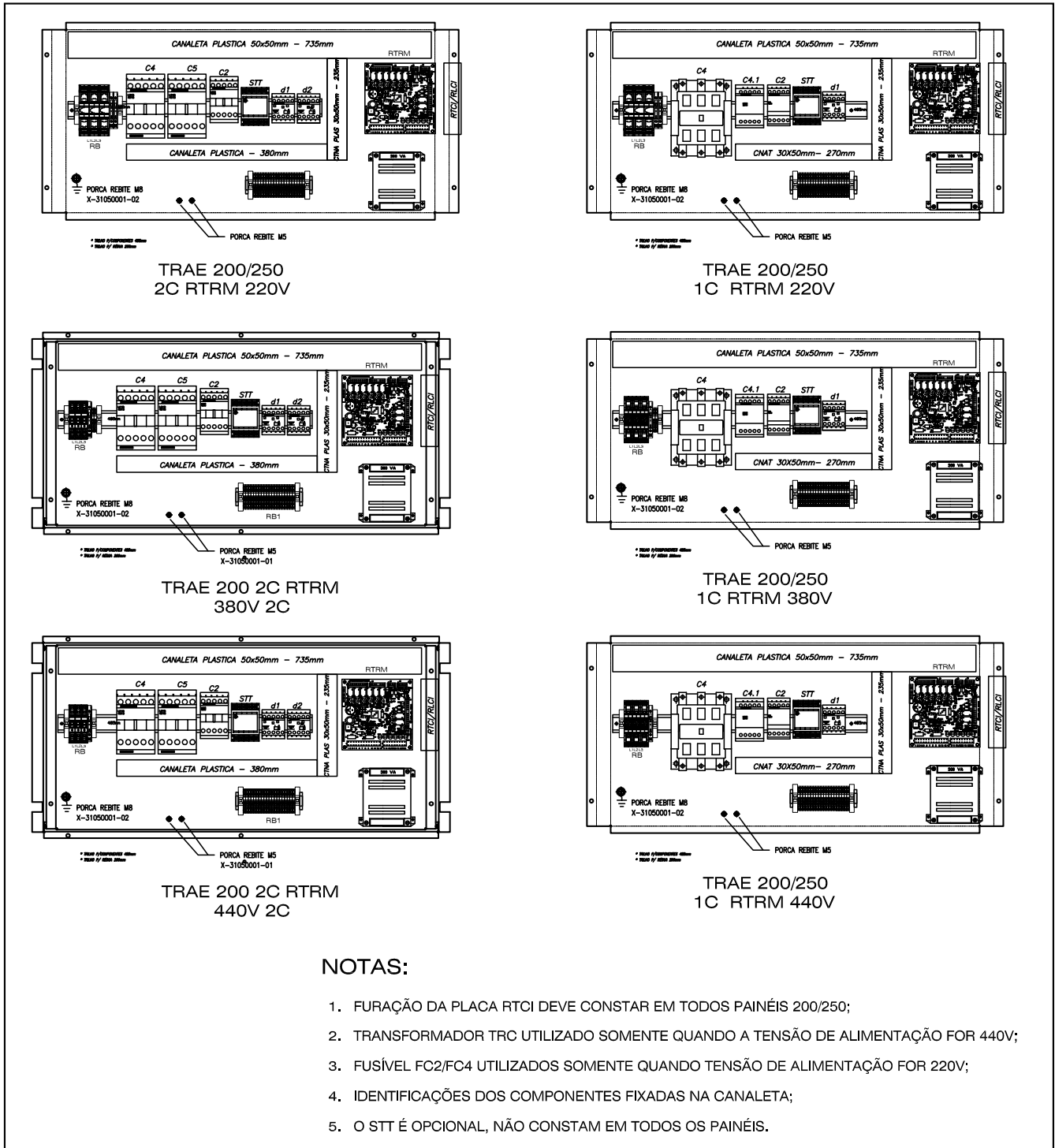

Control Panel Lay Out

TRAE-RGE

Fig. VII-21 - Control Panel Lay Out - TRAE (RGE)

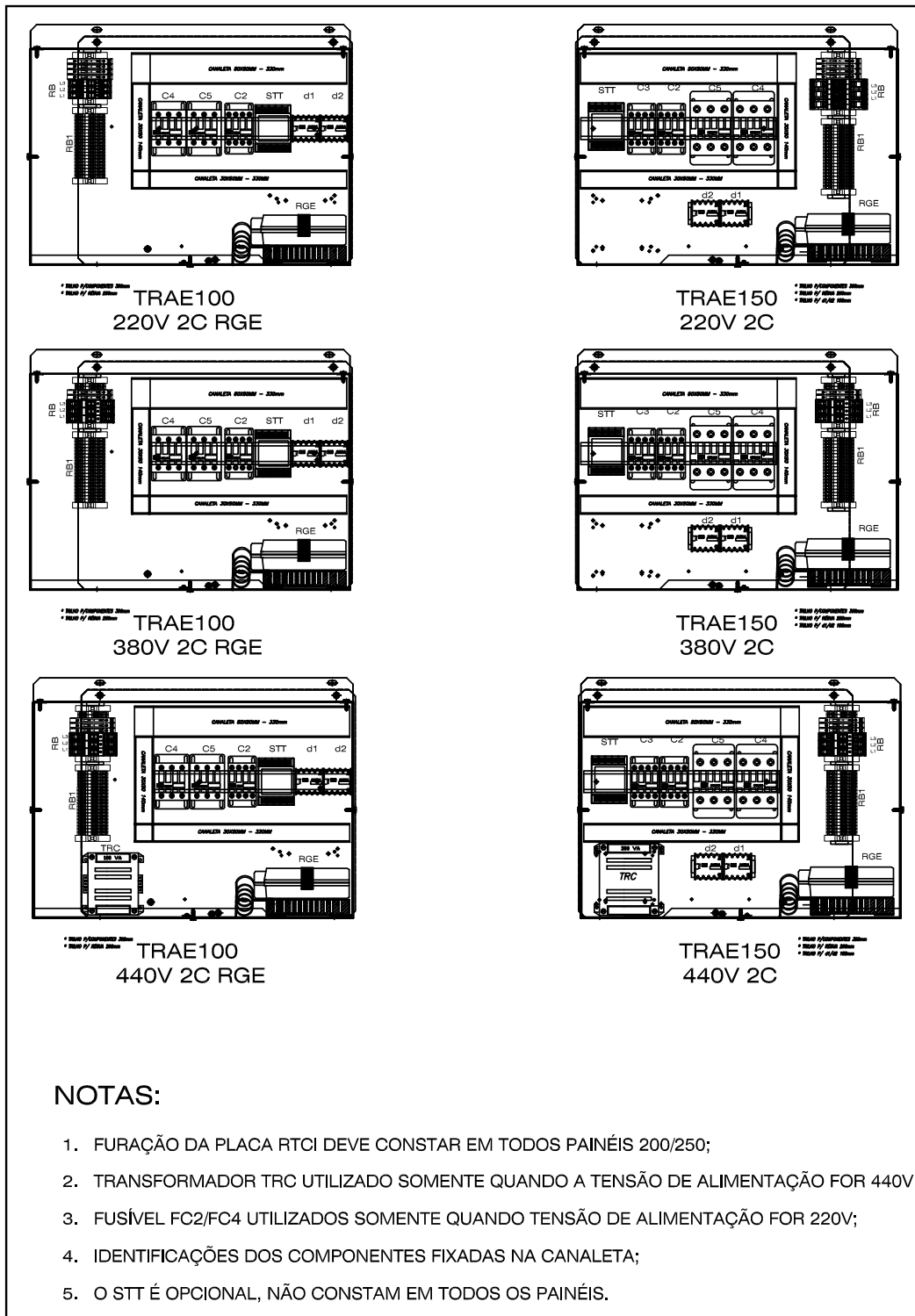

Control Panel Lay Out

TRAE-RGE

Fig. VII-22 - Control Panel Lay Out - TRAE (RGE)

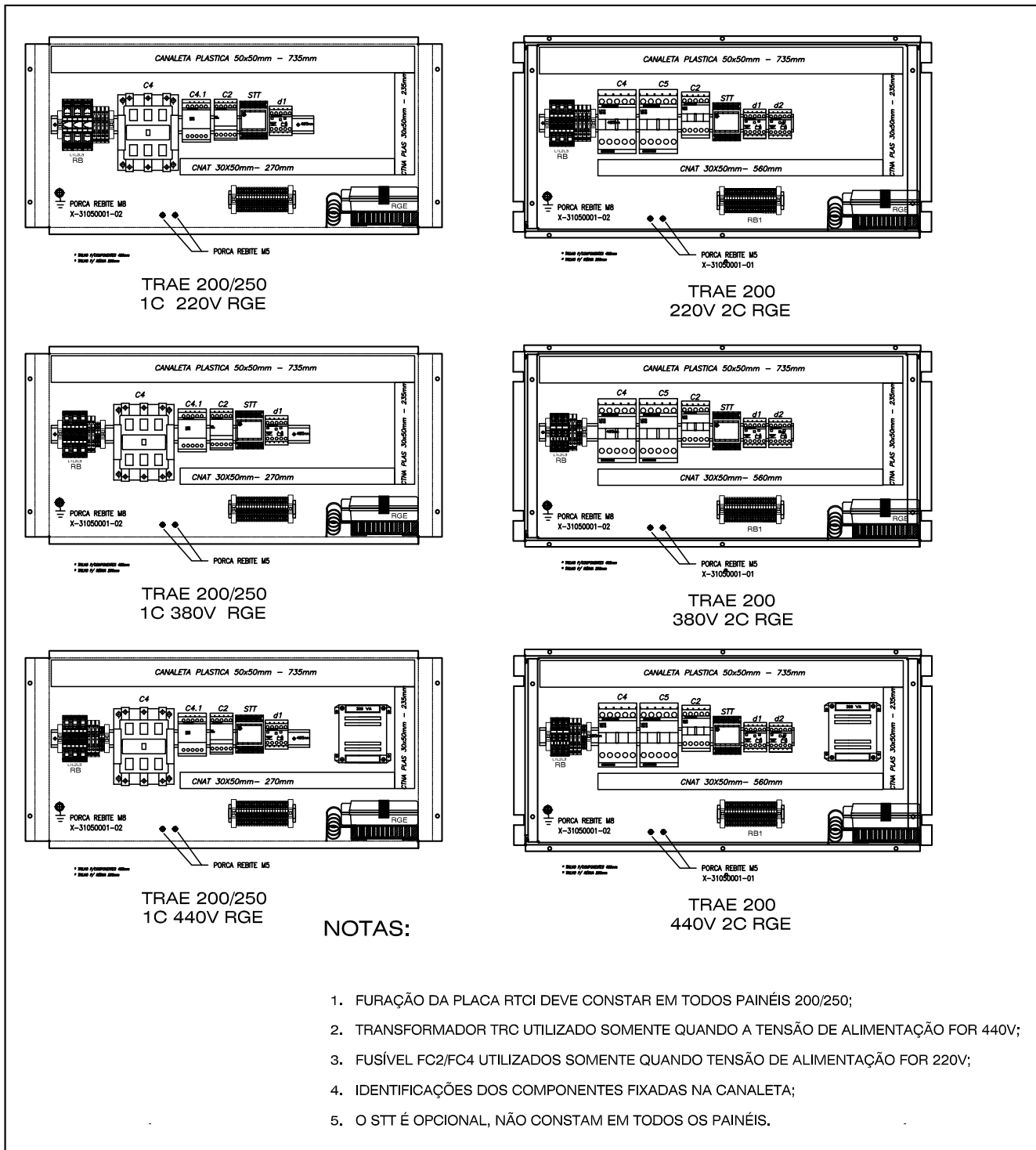

Control Panel Lay Out

TRCE/RTRM

Fig. VII-223- Control Panel Lay Out - TRCE (Standard/RTRM)

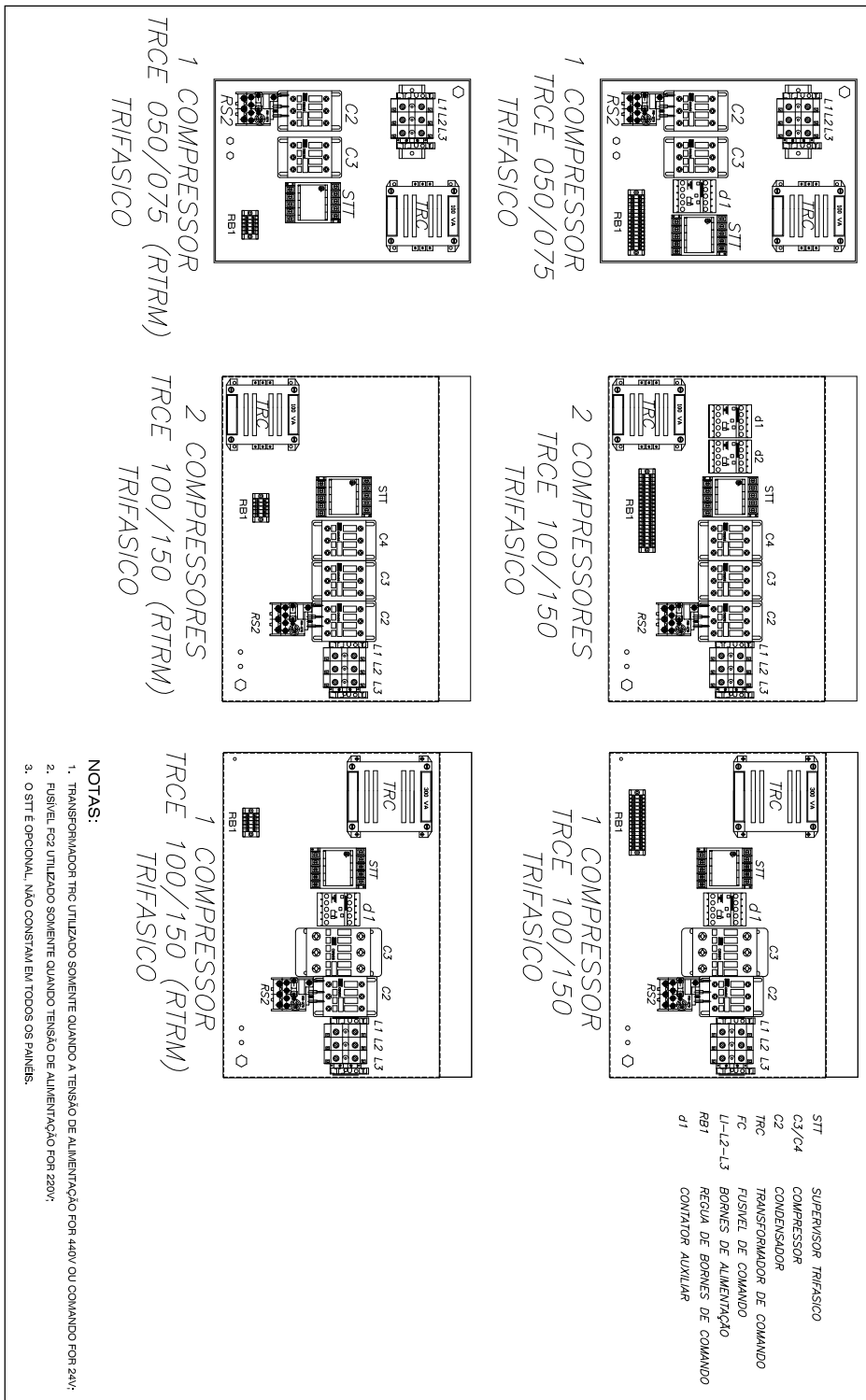

IX-Interconnection Diagram

TRAE-TRCE

Fig. IX-01 - Interconnection Diagram TRAE-TRCE

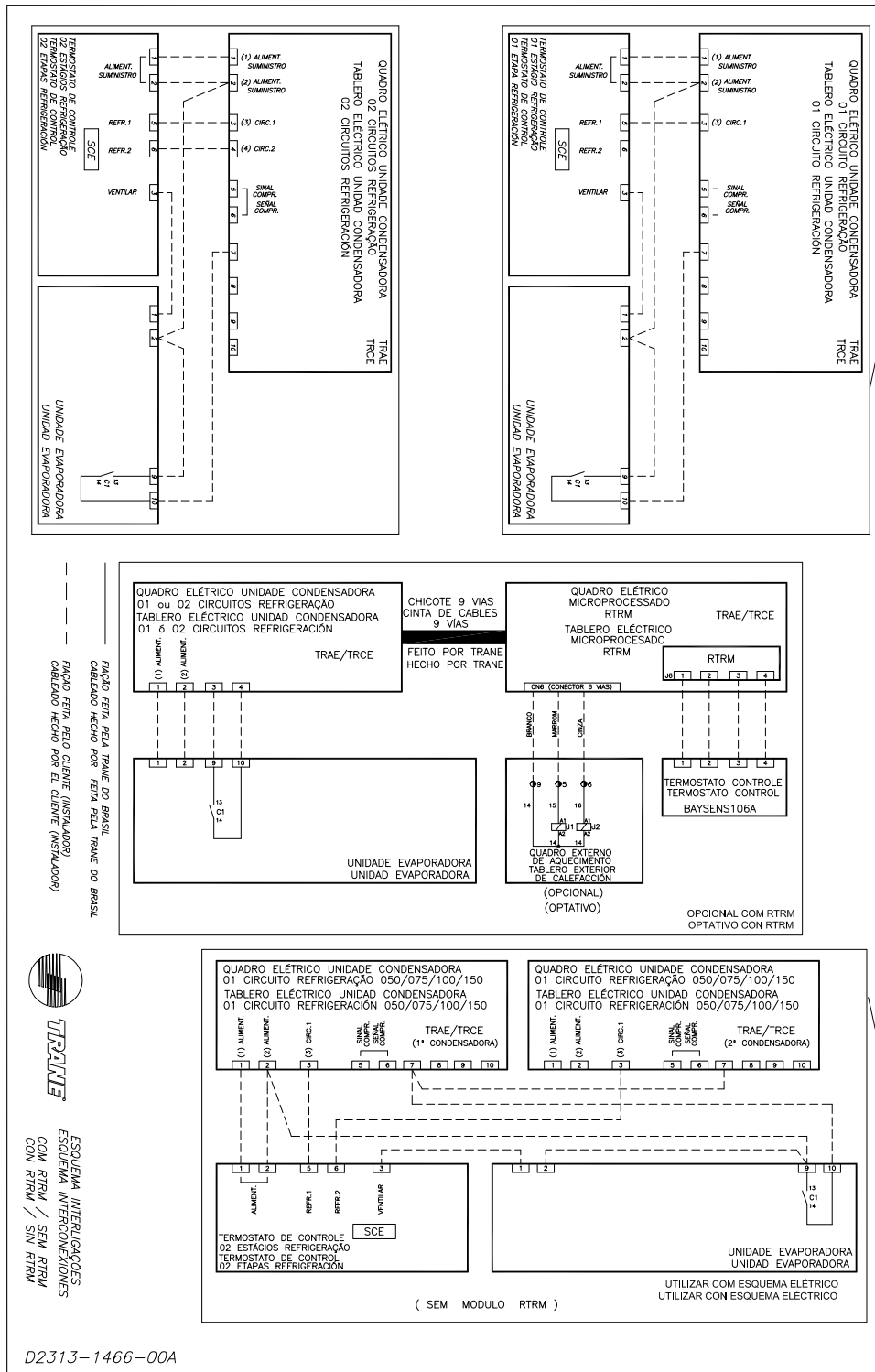

X-Dimensional Data

TRAE

Fig. X-01 - Dimensions - Condensing Units TRAE 050

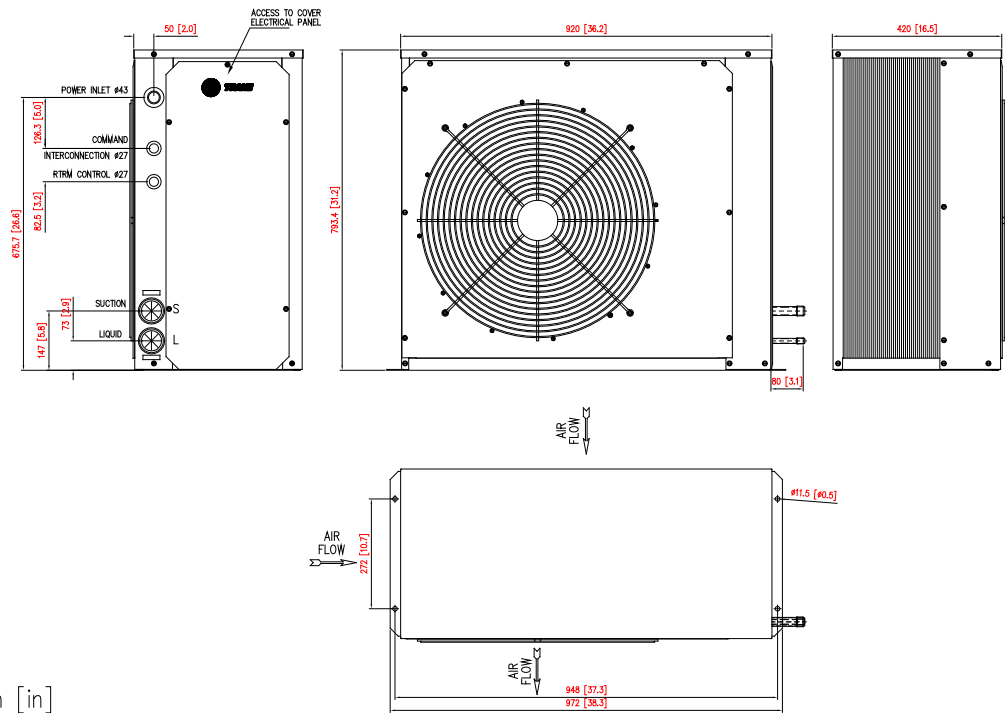

Unit: mm [in]

Fig. X-02 - Dimensions - Condensing Units TRAE 075

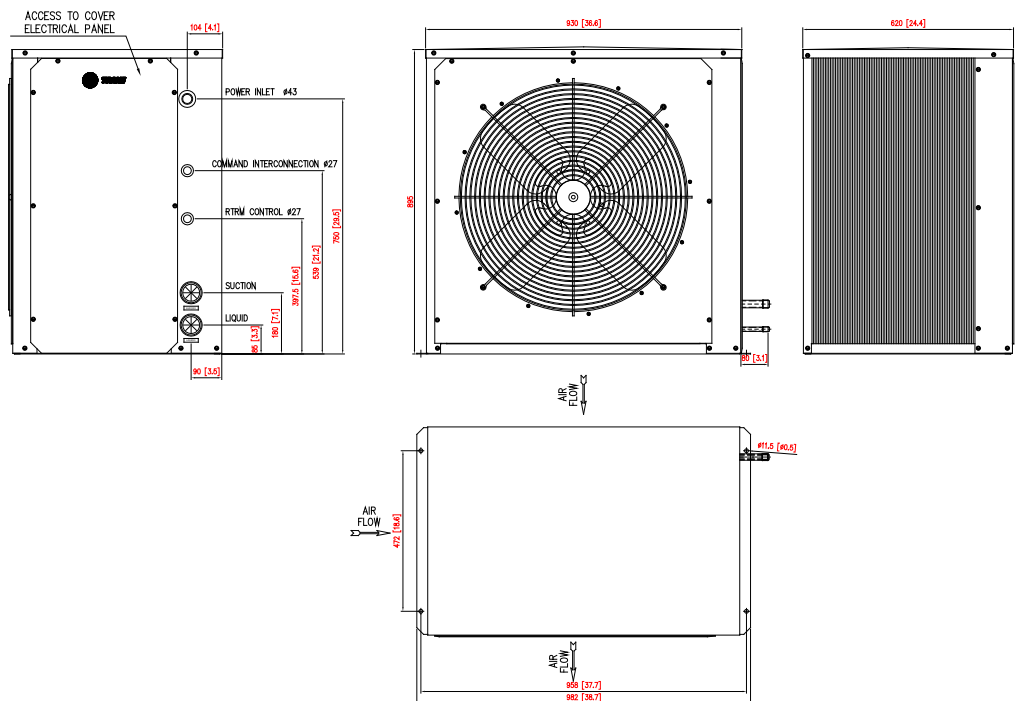

Unit: mm [in]

Dimensional Data

TRAE

Fig. X-03 - Dimensions - Condensing Units TRAE 100 - 1 circuit

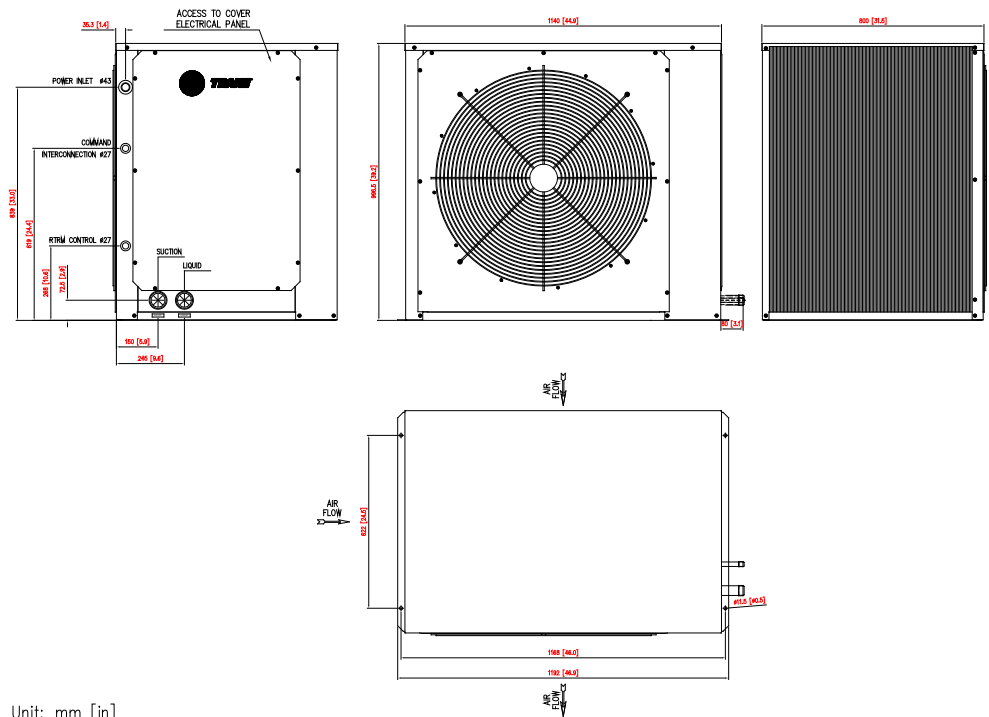

Unit: mm [in]

Fig. X-04 - Dimensions - Condensing Units TRAE 100 - 2 circuits

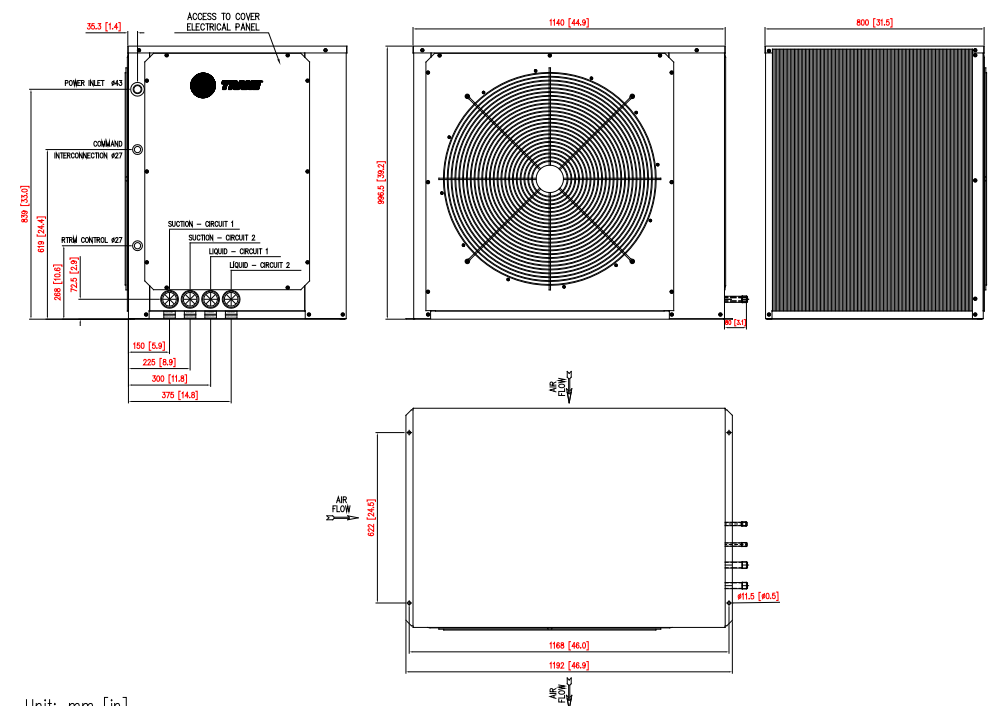

Unit: mm [in]

Dimensional Data

TRAE

Fig. X-05 - Dimensions - Condensing Units TRAE 150 - 1 circuit

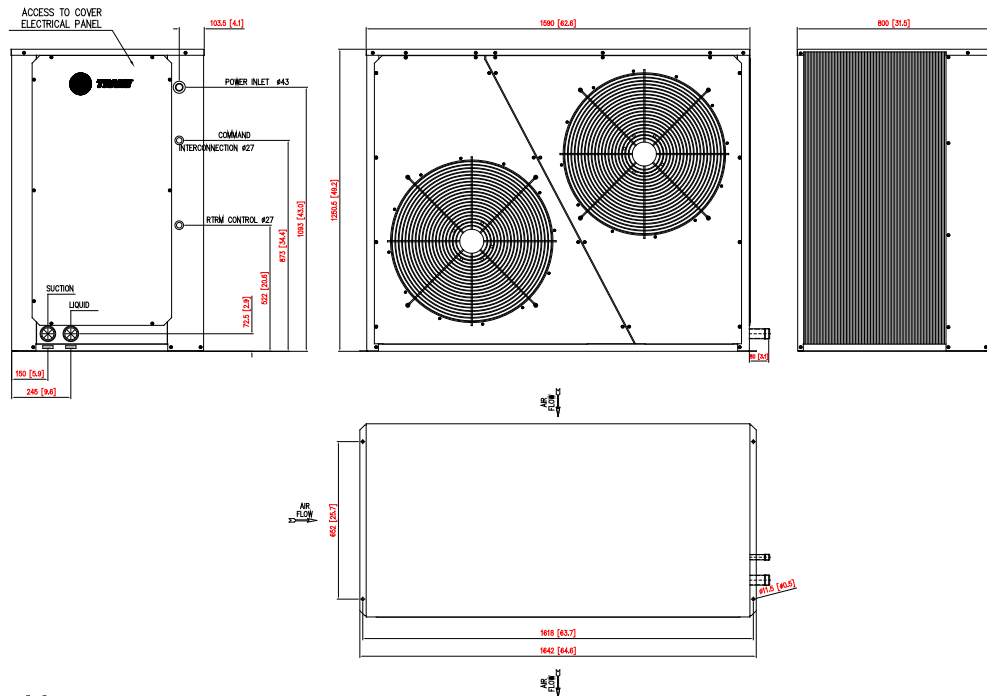

Unit: mm [in]

Dimensional Data

TRAE

Fig. X-06 - Dimensions - Condensing Units TRAE 150 - 2 circuits

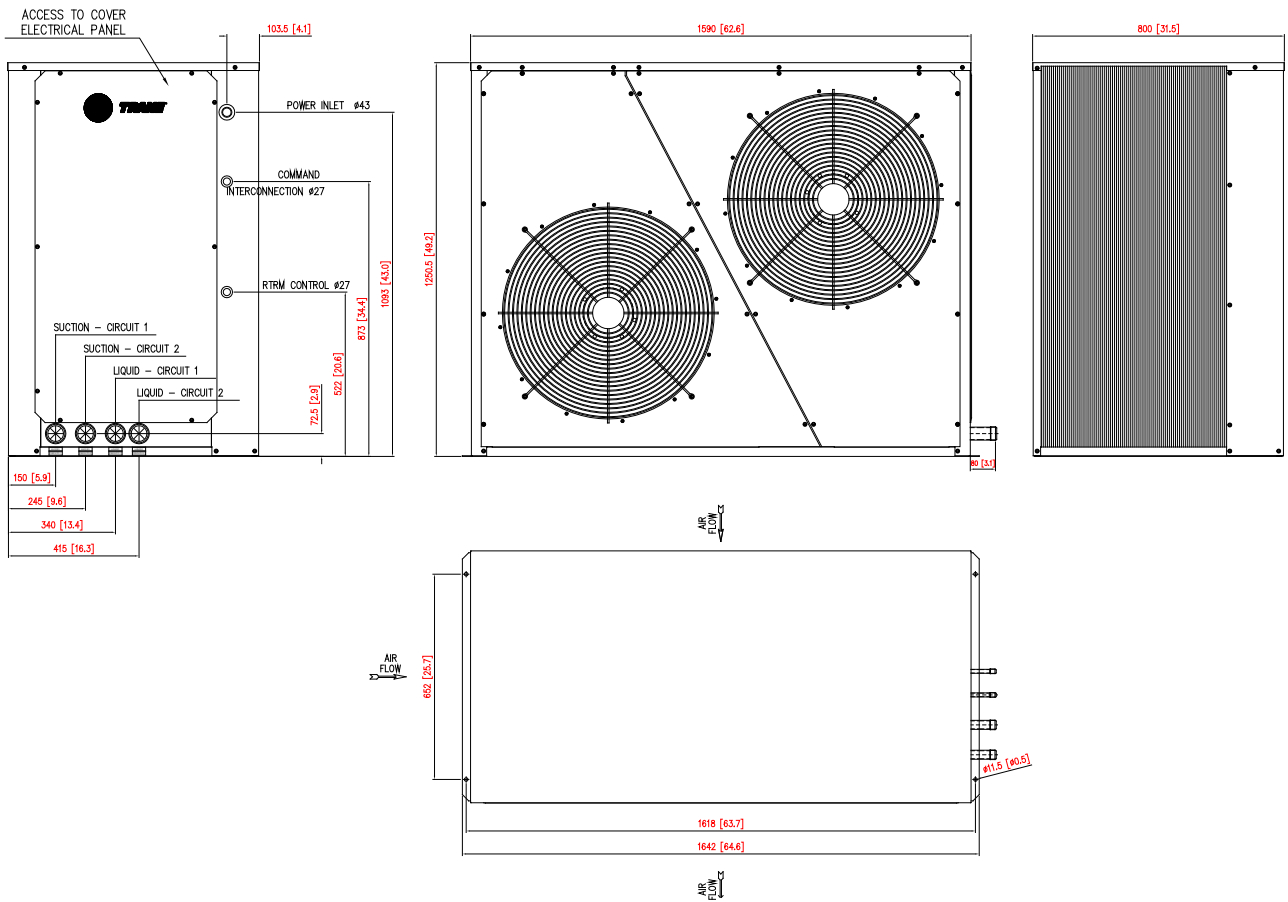

Unit: mm [in]

Dimensional Data

Fig. X-07 - Dimensions - Condensing Units TRAE 200 - 1 Circuit

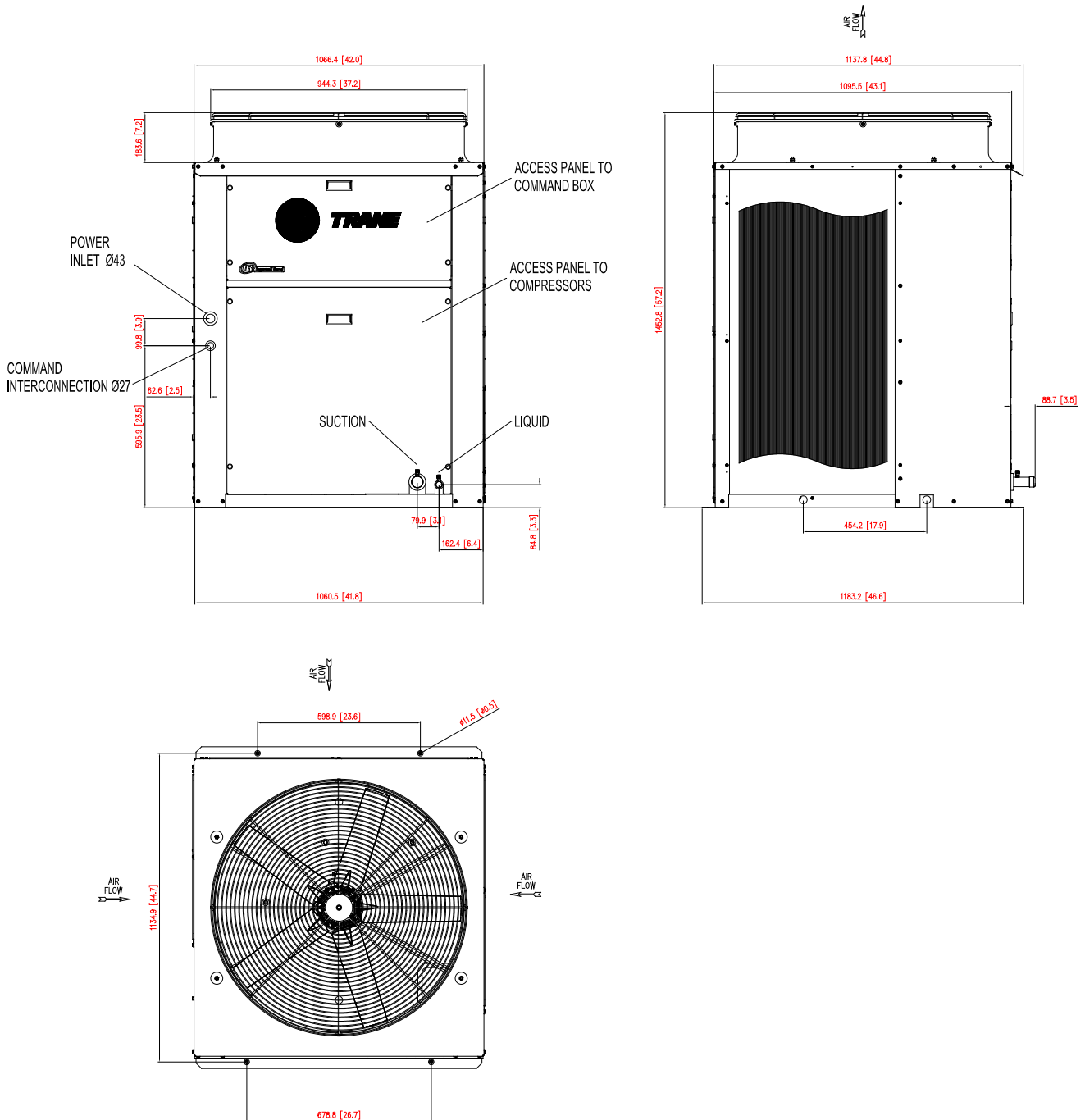

Unit: mm [in]

Dimensional Data

TRAE

Fig. X-08 - Dimensions - Condensing Units TRAE 200 - 2 Circuits

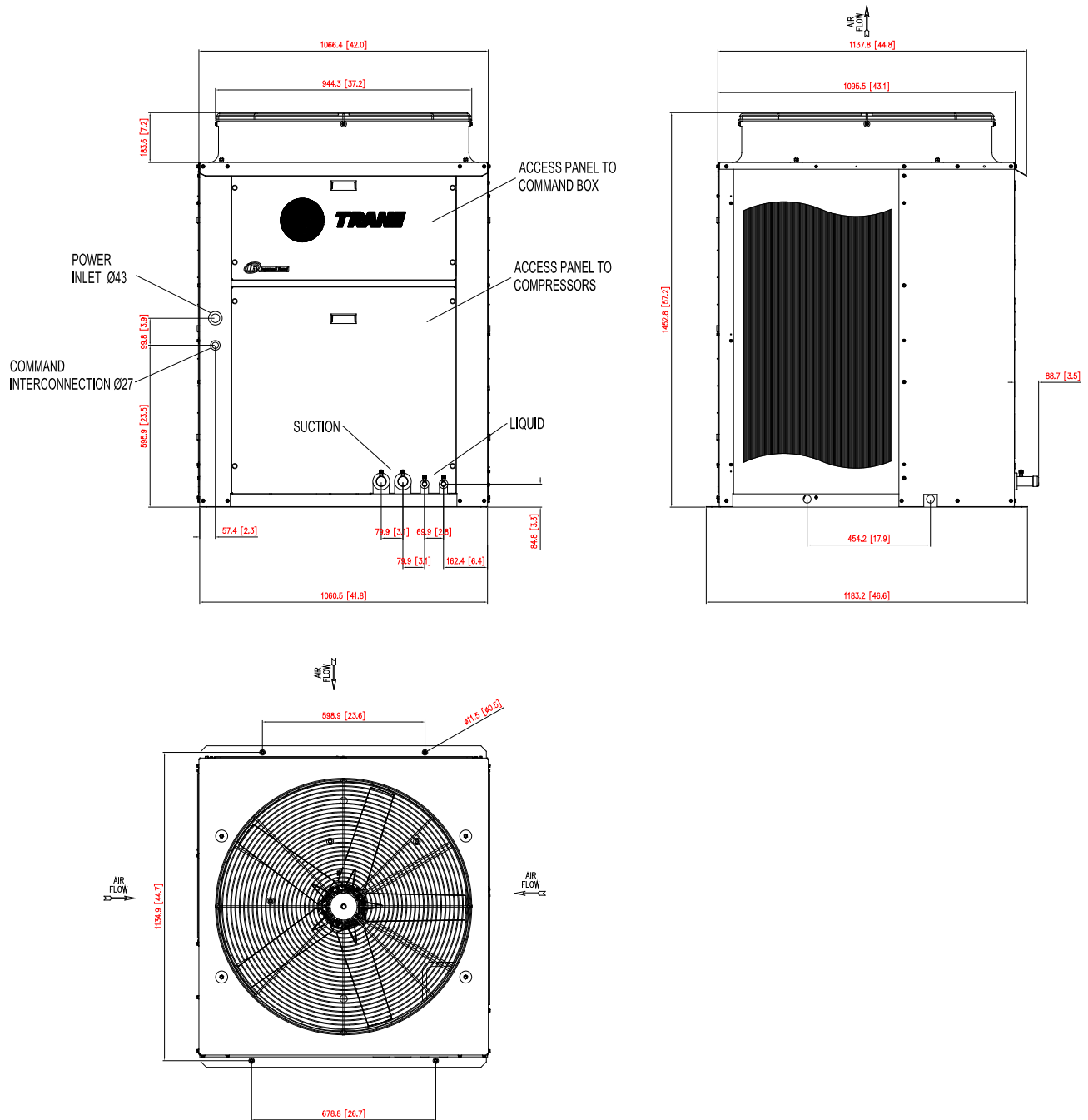

Unit: mm [in]

Dimensional Data

TRAE

Fig. X-09 - Dimensions - Condensing Units TRAE 250 - 1 Circuit

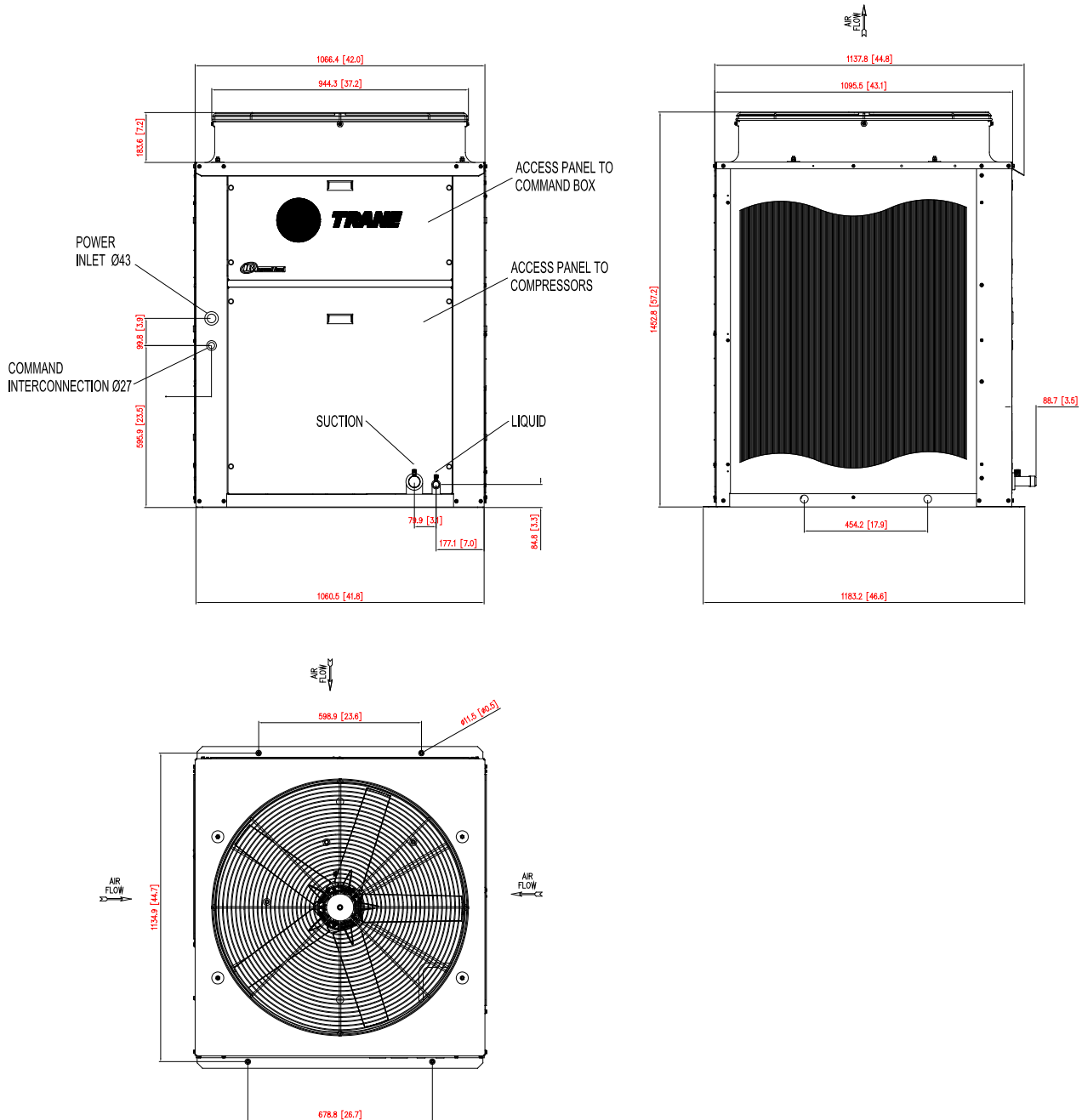

Unit: mm [in]

Dimensional Data

TRAE

Fig. X-10 - Dimensions - Condensing Units TRAE 250 - 2 Circuits

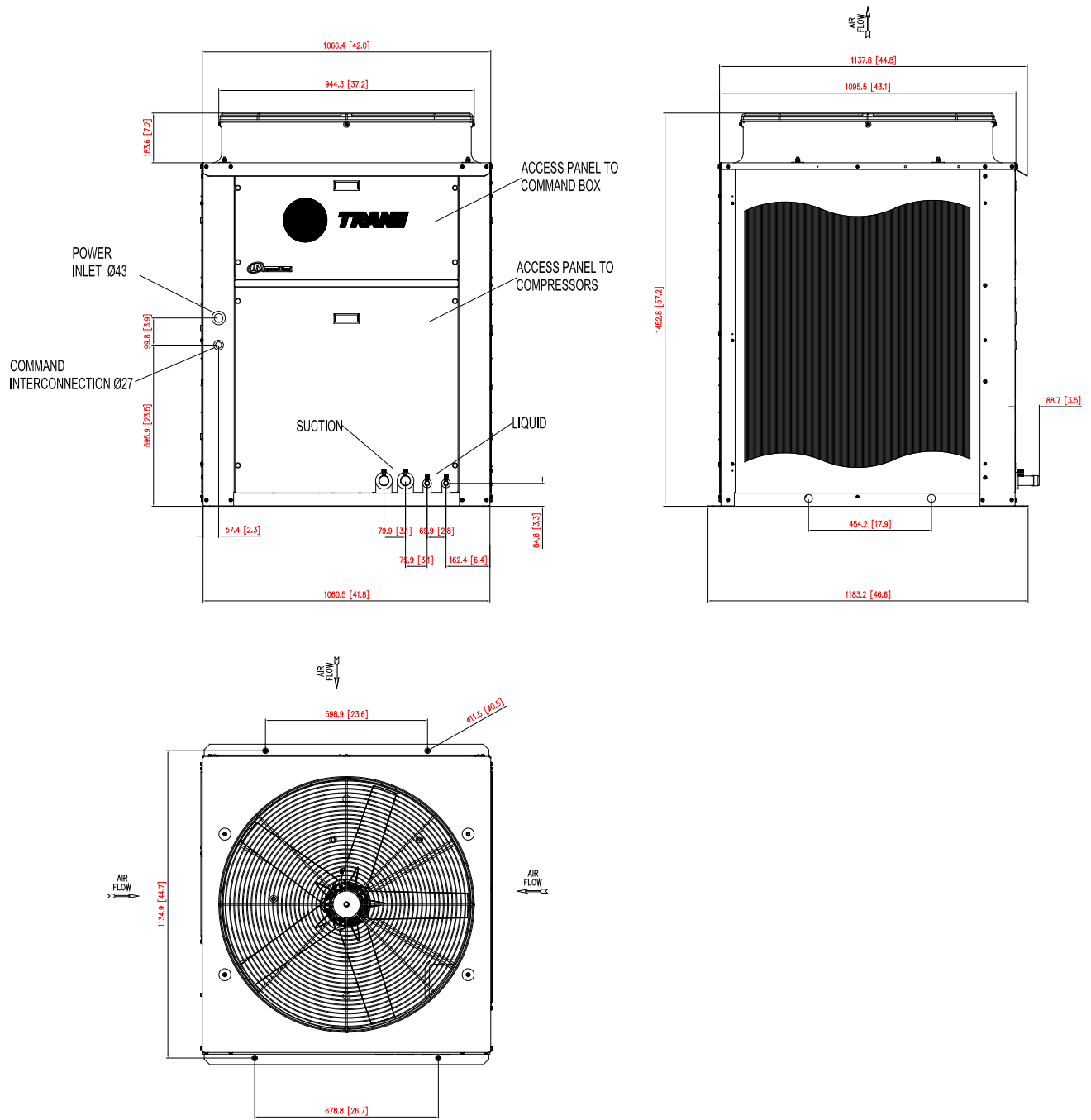

Unit: mm [in]

Dimensional Data

CRCB

Fig. X-11- Dimensions CRCB 050 to 150.

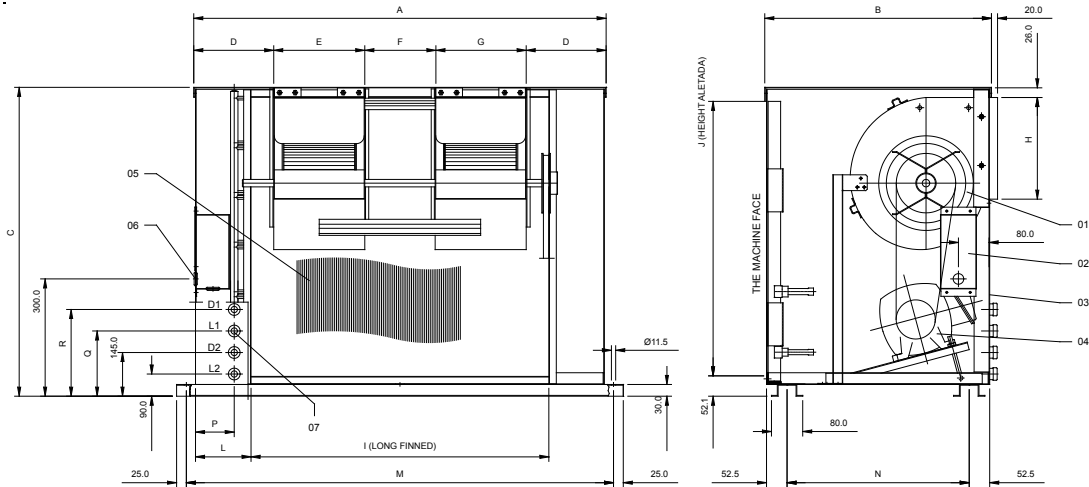

- 1 Double-suction centrifugal fan (evaporator)
- 2 Terminal box
- 3 Maintenance cover
- 4 Three-phase electrical motor
- 5 Condensing coil (Micro-channel)
- 6 Cable passage Ø27 for power inlet
- 7 Refrigeration connections (single position)

Tab. X-01 - Dimensions CRCB 050 to 150.

MODEL	A	B	C	D	E	F	G	H	I	J	L	M	N	P	Q	R	ØL1	ØD1	ØL2	ØD2
050	987	631	890	295.5	396	-	-	341	762	711	110	1029	521	132	-	-	1/2"	5/8"	-	-
075	1241	631	890	422.5	396	-	-	341	1016	816.5	110	1283	521	132	-	-	1/2"	3/4"	-	-
100 C/2	1341	631	941	222.5	333	230	333	289	1143	863.5	97	1383	521	159	200	255	1/2"	5/8"	1/2"	5/8"
125 C/2	1646	714	1018	299.5	396	255	396	341	1473	940	84	1688	604	236	200	255	1/2"	3/4"	1/2"	5/8"
150 C/2	1646	714	1247	299.5	396	255	396	341	1473	1168.5	84	1688	604	236	200	255	1/2"	3/4"	1/2"	3/4"

Note:
Unit: mm

Dimensional Data

CRCE/TRCE

Tab. XI-02 - Dimensions - TRCE/CRCE

	Modelo			
Cota	050	076	100	150
A	922	1146	1420	1640
B	1373	1474	1525	1829
C	560	560	560	560
D	341	341	290	341
E	374	480	402	432
F	386	386	326	386
G	-----	-----	230	255
H	778	879	930	1234
K	813	914	965	1269
L	560	560	560	560

Fig. X-13 - Dimensions - TRCE/CRCE

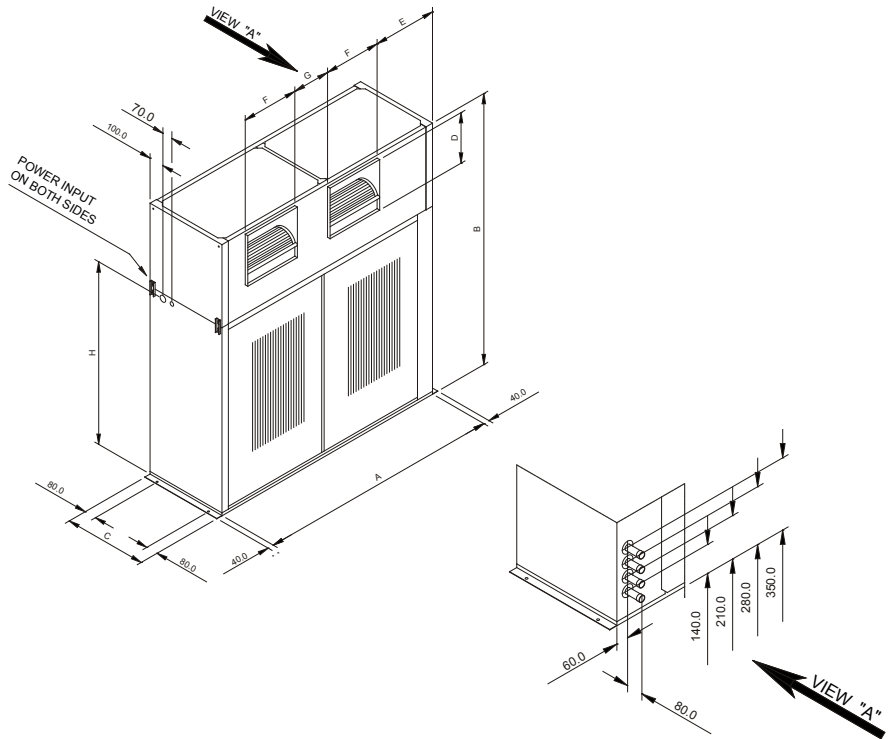
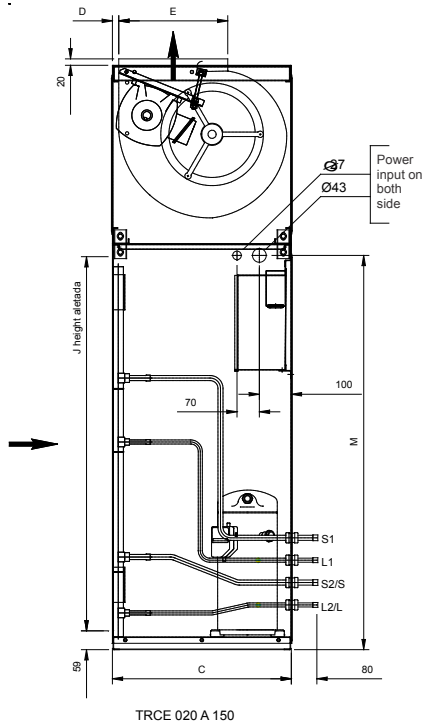

Fig. X-12 - Connections - condensing unit TRCE



Tab.X-03 - Dimensions - TRCE/CRCE

	Measures (mm)					
	C	D	E	J	M	
Models TRCE	50	560	20	341	711	778
	75	560	20	341	813	879
100C/1	560	95	290	864	930	
150C/1	560	20	341	1168	1234	

Tab. X-04 - Connection dimensions - TRCE

		Models TRCE					
		050	075	100C/1	100C/2	150C/1	150C/2
Connections (pol)	S1	7/8"	...	1 1/8"
	L1	1/2"	...	1/2"
	S2/S	7/8"	1 1/8"	1 3/8"	7/8"	1 5/8"	1 1/8"
	L2/L	1/2"	1/2"	5/8"	1/2"	7/8"	1/2"

XI-Application Considerations

Fig. XI-14 - Clearances required for Maintenance and Air Circulation - TRAE

Suggestes clearances TRAE 050 to 150 - Horizontal Discharge

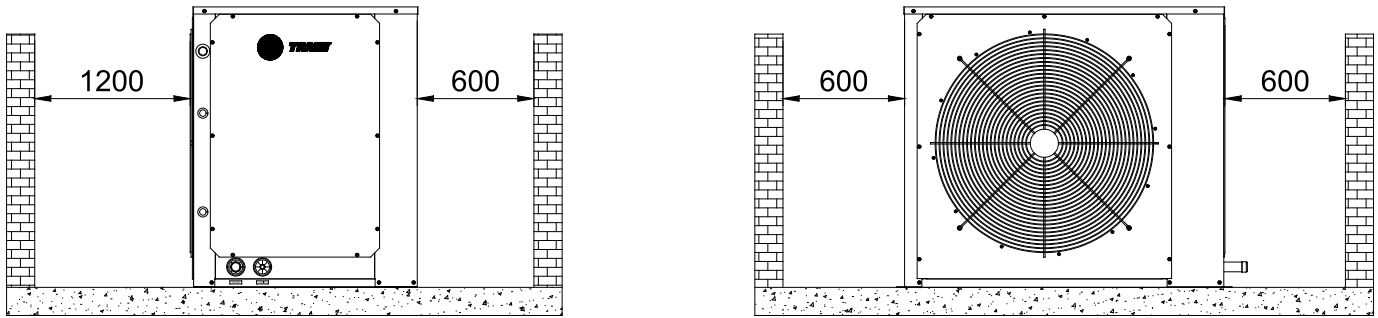

Suggested clearances TRAE 200 to 250 - Vertical Discharge

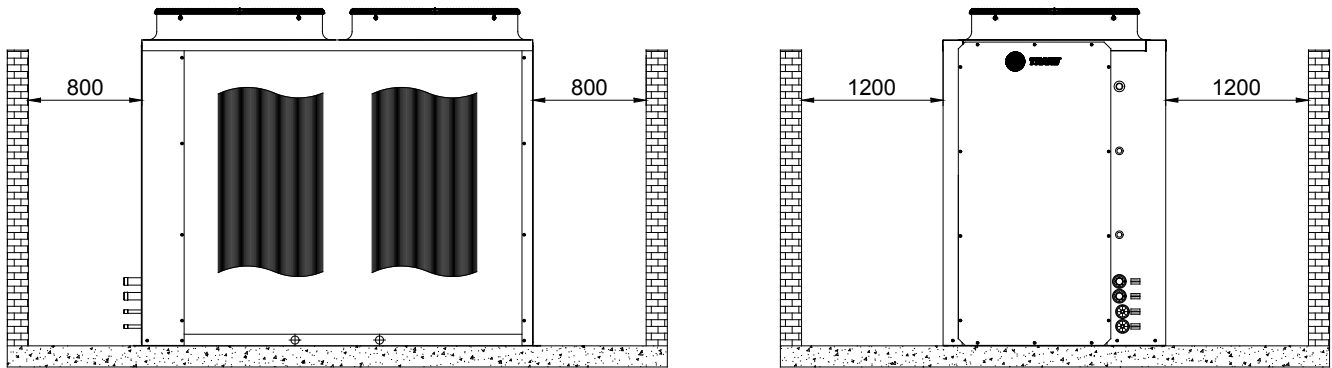
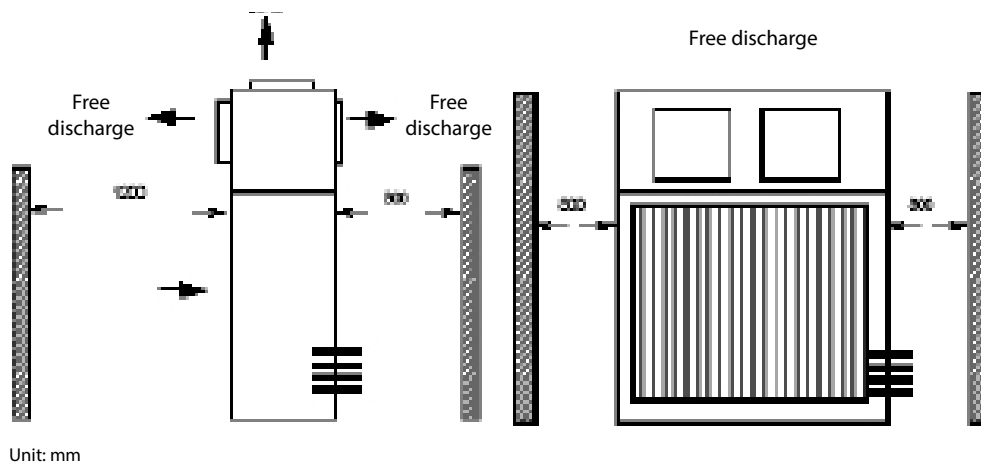

Fig. XI-15 - Suggested Clearances for Maintenance and Air Circulation - Condensing Unit TRCE 050 to 150.





XII-Standard Conversion Table

To convert from:	To:	Multiply By:	To convert from:	To:	Multiply By:
Length			Velocity		
Feet (ft)	meters (m)	0,30481	Feet per minute (ft/min)	meters per second (m/s)	0,00508
Inche (in)	milimeters (mm)	25,4	Feet per second (ft/s)	meters per second (m/s)	0,3048
Area			Energy, Power and Capacity		
Square feet (ft ²)	square meters(m ²)	0,93	British Thermal Units (BTU)	Kilowatt (kW)	0,000293
Square inche(in ²)	square milimeters(mm ²)	645,2	British Thermal Units (BTU)	Kilocalorie (kcal)	0,252
			Tons (refrig. Effect)	Kilowatt (kW)	3,516
Volume			Tons (refrig. Effect)	Kilocalorie per hour (kcal/h)	3024
Cubic feet (ft ³)	cubic meters(m ³)	0,0283	Horsepower (HP)	Kilowatt (kW)	0,7457
Cubic Inches (in ³)	cubic milimeters (mm ³)	16387			
Gallons (gal)	litres (L)	3,785			
Gallons (gal)	cubic meters (m ³)	0,003785	Pressão		
Flow			Feet of water (ft.H ₂ O)	Pascal (Pa)	2990
Cubic feet / min (cfm)	cubic meters / second (m ³ /s)	0,000472	Inches os water (in.H ₂ O)	Pascal (Pa)	249
Cubic feet / min (cfm)	cubic meters / hour (m ³ /h)	1,69884	Pounds per square inch (PSI)	Pascal (Pa)	6895
Gallons / min (GPM)	cubic meters / hour (m ³ /h)	0,2271	Pounds per square inch (PSI)	Bar ou kg/cm ²	6,895 x 10 ⁻²
Gallons / min (GPM)	litres / second (L/s)	0,06308			
			Peso		
			Ounces (oz)	Kilograms (kg)	0,02835
			Pounds (lbs)	Kilograms (kg)	0,4536

Temperature		
°C	C ou F	°F
-40,0	-40	-40
-39,4	-39	-38,2
-38,9	-38	-36,4
-38,3	-37	-34,6
-37,8	-36	-32,8
-37,2	-35	-31
-36,7	-34	-29,2
-36,1	-33	-27,4
-35,6	-32	-25,6
-35,0	-31	-23,8
-34,4	-30	-22
-33,9	-29	-20,2
-33,3	-28	-18,4
-32,8	-27	-16,6
-32,2	-26	-14,8
-31,7	-25	-13
-31,1	-24	-11,2
-30,6	-23	-9,4
-30,0	-22	-7,6
-29,4	-21	-5,8
-28,9	-20	-4
-28,3	-19	-2,2
-27,8	-18	-0,4
-27,2	-17	1,4
-26,7	-16	3,2
-26,1	-15	5
-25,6	-14	6,8
-25,0	-13	8,6
-24,4	-12	10,4
-23,9	-11	12,2
-23,3	-10	14
-22,8	-9	15,8
-22,2	-8	17,6
-21,7	-7	19,4
-21,1	-6	21,2
-20,6	-5	23
-20,0	-4	24,8
-19,4	-3	26,6
-18,9	-2	28,4
-18,3	-1	30,2
-17,8	0	32
-17,2	1	33,8
-16,7	2	35,6
-16,1	3	37,4
-15,6	4	39,2

Temperature		
°C	C ou F	°F
-15,0	5	41
-14,4	6	42,8
-13,9	7	44,6
-13,3	8	46,4
-12,8	9	48,2
-12,2	10	50
-11,7	11	51,8
-11,1	12	53,6
-10,6	13	55,4
-10,0	14	57,2
-9,4	15	59
-8,9	16	60,8
-8,3	17	62,6
-7,8	18	64,4
-7,2	19	66,2
-6,7	20	68
-6,1	21	69,8
-5,6	22	71,6
-5,0	23	73,4
-4,4	24	75,2
-3,9	25	77
-3,3	26	78,8
-2,8	27	80,6
-2,2	28	82,4
-1,7	29	84,2
-1,1	30	86
-0,6	31	87,8
0,0	32	89,6
0,6	33	91,4
1,1	34	93,2
1,7	35	95
2,2	36	96,8
2,8	37	98,6
3,3	38	100,4
3,9	39	102,2
4,4	40	104
5,0	41	105,8
5,6	42	107,6
6,1	43	109,4
6,7	44	111,2
7,2	45	113
7,8	46	114,8
8,3	47	116,6
8,9	48	118,4
9,4	49	120,2

Temperature		
°C	C ou F	°F
10,0	50	122
10,6	51	123,8
11,1	52	125,6
11,7	53	127,4
12,2	54	129,2
12,8	55	131
13,3	56	132,8
13,9	57	134,6
14,4	58	136,4
15,0	59	138,2
15,6	60	140
16,1	61	141,8
16,7	62	143,6
17,2	63	145,4
17,8	64	147,2
18,3	65	149
18,9	66	150,8
19,4	67	152,6
20,0	68	154,4
20,6	69	156,2
21,1	70	158
21,7	71	159,8
22,2	72	161,6
22,8	73	163,4
23,3	74	165,2
23,9	75	167
24,4	76	168,8
25,0	77	170,6
25,6	78	172,4
26,1	79	174,2
26,7	80	176
27,2	81	177,8
27,8	82	179,6
28,3	83	181,4
28,9	84	183,2
29,4	85	185
30,0	86	186,8
30,6	87	188,6
31,1	88	190,4
31,7	89	192,2
32,2	90	194
32,8	91	195,8
33,3	92	197,6
33,9	93	199,4
34,4	94	201,2

Temperature		
°C	C ou F	°F
35,0	95	203
35,6	96	204,8
36,1	97	206,6
36,7	98	208,4
37,2	99	210,2
37,8	100	212
38,3	101	213,8
38,9	102	215,6
39,4	103	217,4
40,0	104	219,2
40,6	105	221
41,1	106	222,8
41,7	107	224,6
42,2	108	226,4
42,8	109	228,2
43,3	110	230
43,9	111	231,8
44,4	112	233,6
45,0	113	235,4
45,6	114	237,2
46,1	115	239
46,7	116	240,8
47,2	117	242,6
47,8	118	244,4
48,3	119	246,2
48,9	120	248
49,4	121	249,8
50,0	122	251,6
50,6	123	253,4
51,1	124	255,2
51,7	125	257
52,2	126	258,8
52,8	127	260,6
53,3	128	262,4
53,9	129	264,2
54,4	130	266
55,0	131	267,8
55,6	132	269,6
56,1	133	271,4
56,7	134	273,2
57,2	135	275
57,8	136	276,8
58,3	137	278,6
58,9	138	280,4
59,4	139	282,2

Temperature		
°C	C ou F	°F
60,0	140	284
60,6	141	285,8
61,1	142	287,6
61,7	143	289,4
62,2	144	291,2
62,8	145	293
63,3	146	294,8
63,9	147	296,6
64,4	148	298,4
65,0	149	300,2
65,6	150	302
66,1	151	303,8
66,7	152	305,6
67,2	153	307,4
67,8	154	309,2
68,3	155	311
68,9	156	312,8
69,4	157	314,6
70,0	158	316,4
70,6	159	318,2
71,1	160	320
71,7	161	321,8
72,2	162	323,6
72,8	163	325,4
73,3	164	327,2
73,9	165	329
74,4	166	330,8
75,0	167	332,6
75,6	168	334,4
76,1	169	336,2
76,7	170	338
77,2	171	339,8
77,8	172	341,6
78,3	173	343,4
78,9	174	345,2
79,4	175	347
80,0	176	348,8
80,6	177	350,6
81,1	178	352,4
81,7	179	354,2
82,2	180	356
82,8	181	357,8
83,3	182	359,6
83,9	183	361,4
84,4	184	363,2



Trane optimizes the performance of homes and buildings around the world. A business of Ingersoll Rand, the leader in creating and sustaining safe, comfortable and energy efficient environments, Trane offers a broad portfolio of advanced controls and HVAC systems, comprehensive building services, and parts. For more information, visit www.trane.com.br

Trane has a policy of continuous product and product data improvement and reserves the right to change design and specifications without notice.

© 2017 Trane
All rights reserved
SSC-SVN008G-EN December 2017
Supersedes SSC-SVN008F-EN February 2017

Produced with paper that uses fewer trees and chemicals, less energy, and environmentally friendly print practices that reduce waste.

