



Installation Operation Maintenance

**Split System Evaporator Unit - 5 to 50 Ton
Fan and Coil Modules
Onix Split System - CXPA
60 Hz**



SAFETY WARNING

Only qualified personnel should install and service the equipment. The installation, starting up, and servicing of heating, ventilating, and air-conditioning equipment can be hazardous and requires specific knowledge and training. Improperly installed, adjusted or altered equipment by an unqualified person could result in death or serious injury. When working on the equipment, observe all precautions in the literature and on the tags, stickers, and labels that are attached to the equipment.



Important Notice

Literature Change History

This manual describes the installation, operation and maintenance procedures for the CXPA evaporator units of the Trane Onix Split System.

IMPORTANT:

Dimensional measuring units on this catalog are on millimeters (mm). (Exept for those locally referencied).

Refrigerant Emission Control

Gas conservation and emission reduction should be accomplished by adhering to operational and service procedures recommended by Trane, with special attention to the following:

The refrigerant used in any type of AC equipment must be always recovered and/or recycled for reuse, reclaimed or completely destroyed after being removed from the unit.

Never release the refrigerant to the atmosphere.

Always consider the possibility of recycling or reprocessing the refrigerant before starting the reclaim process by any method.

The ARI 700 Standard covers questions about recovered refrigerant and acceptable quality.

Use only approved and safe cylinders. All applicable safety and shipping standards must be met during the transportation of refrigerant containers.

Recycling equipment should be used to minimize emissions during the transfer of refrigerant gas. Always use methods that generate the lowest possible vacuum during the recovery and condensation of refrigerant into the cylinder.

Important:

Trane has a policy of continuous product development and reserves the right to change design and specifications without notice. Only qualified technicians or technicians authorized by Trane should perform the installation and servicing of equipment referred to in this publication. Failure to comply with and/or adhere to the procedures in this manual may void the product warranty.

Table of Contents

Important Notice	2
General Data	4
Unit Inspection	6
Transport and Handling	7
Installation Procedures	8
Refrigeration Piping (Interconnection)	9
Operation	10
Maintenance Procedures	11
Periodical Preventive Maintenance	13
Electrical Data	15
Wiring Diagram	16
Dimensional Data	17
Conversion Table	36



General Data

050 to 500

Tab. 01 - General Data - Coil and Fan Modules - CXPA 050 to 500

		CXPA 050	CXPA 075	CXPA 100	CXPA 125	CXPA 150	CXPA 200	CXPA 250	CXPA 300	CXPA 350	CXPA 400	CXPA 500				
Rated Capacity	Ton	5	7.5	10	12.5	15	20	25	30	35	40	50				
Coil Module																
Number of circuits		1	1	2	2	1	2	1	2	2	2	2				
Length	mm	950	1135	1420	1420	1470	1470	1920	1920	1870	1870	2200	2770	2770	2770	
Depth	mm	485	565	660	660	580	580	670	670	800	800	800	800	900	900	
Height	mm	510	590	585	585	770	940	880	880	1100	1100	1100	1100	1220	1490	
Copper Pipe Dia.	in.	3/8"	3/8"	3/8"	3/8"	3/8"	3/8"	1/2"	1/2"	1/2"	1/2"	1/2"	1/2"	1/2"	1/2"	
Rows		3	3	3	3	3	3	3	3	3	3	3				
FPF Fins per foot)		132	144	132	132	144	144	156	156	156	156	156	156	156	156	
Finned Face Area	m²	0.37	0.56	0.71	0.71	0.93	1.11	1.11	1.47	1.47	1.83	1.83	2.21	2.61	2.97	3.72
Air Filters																
Size 1	mm	457 x 457	457 x 508	457 x 508	457 x 508	356 x 356	356 x 356	356 x 356	381 x 778	381 x 778	305 x 508	305 x 508	381 x 508	457 x 508	457 x 508	483 x 686
Qty 1		2	1	3	3	8	4	4	4	4	12	12	8	10	5	10
Size 2	mm	--	508 x 635	--	--	--	356 x 508	356 x 508	305 x 778	305 x 778	--	--	305 x 508	406 x 508	406 x 508	305 x 686
Qty 2		--	1	--	--	--	4	4	1	1	--	--	4	2	1	2
Size 3	mm	--	--	--	--	--	--	--	--	--	--	--	--	--	457x610	--
Qty 3		--	--	--	--	--	--	--	--	--	--	--	--	--	5	--
Size 4	mm	--	--	--	--	--	--	--	--	--	--	--	--	--	406 x 610	--
Qty 4		--	--	--	--	--	--	--	--	--	--	--	--	--	1	--
Fan Module																
Length	mm	950	1135	1420	1420	1470	1470	1920	1920	1870	1870	2200	2770	2770	2770	
Depth	mm	485	565	660	660	580	580	670	670	800	800	800	800	900	900	
Height	mm	510	590	690	690	830	830	1000	1000	1100	1100	1100	1100	1220	1220	
Transmission Option																
Number of Fans		1	1	1	1	2	2	2	2	2	2	2	3	3	3	
Standard	HP	0.75	1.0	1.5	1.5	2.0	3.0	3.0	4.0	4.0	4.0	4.0	5.0	7.5	7.5	7.5
Opção 1	HP	1.0	2.0	2.0	2.0	3.0	4.0	4.0	6.0	6.0	6.0	6.0	7.5	10.0	10.0	12.5
Opção 2	HP	1.5	3.0	4.0	4.0	5.0	5.0	5.0	7.5	7.5	10.0	10.0	10.0	12.5	12.5	15.0
Air Flow - Min	m³/h	2720	4080	5440	5440	6800	8160	8160	10880	10880	13600	13600	16320	19040	21760	27200
Air Flow - Nom.	m³/h	3400	5100	6800	6800	8500	10200	10200	13600	13600	17000	17000	20400	23800	27200	34000
Air Flow - Max	m³/h	4000	6000	8000	8000	10000	12000	12000	16320	16320	20400	20400	24480	28560	32640	40000

Notes:

- (1) Length, depth and height data showed in this table 1 (above) are nominal reference values, that may vary depending on fan discharge and module mounting options. Refer to dimensional drawings for the modules in this publication.
- (2) Capacity are based on ARI 210 for equipments up to 5,0 TR and ARI 340 for equipments exceeding 5,0 TR.

Tab. 01a - Nominal Weight - Coil and Fan Modules - CXPA 050 to 500

		CXPA 050	CXPA 075	CXPA 100	CXPA 125	CXPA 150	CXPA 200	CXPA 250	CXPA 300	CXPA 350	CXPA 400	CXPA 500
Nominal Cap.	Ton	5	7.5	10	12.5	15	20	25	30	35	40	50
Nominal weight (kg) according to the transmission option selected.												
Transmission - Standard		108	145	156	221	237	362	400	439	578	682	724
Transmission - Option 1		113	148	159	225	245	372	410	464	590	694	744
Transmission - Option 2		113	152	171	235	247	377	427	476	598	702	748

Note:

- (1) CXPA equipment nominal weight varies according to the transmission option selected for the model.

General Data

TRAE/TRCE
Tab. 02 - General Data - Condensing Units TRAE - 050 to 250

Model	50	75	100	150	200	250
Nominal Cap.	Ton 5	7,5	10	15	20	25
Dimensions						
Width	mm 920	930	1140	1590	1067	1067
Depth	mm 420	620	800	800	1096	1096
Height	mm 818	920	1021	1275	1452	1452
Compressor						
Type	Scroll	Scroll	Scroll	Scroll	Scroll	Scroll
Qty.	Ton 1/5	1/7,5	1/10 2x5	1/15 2x7,5	1/20 2x10	1/25 or 2x12,5
Condensing Coil						
Rows	2	2	2	2	2	2 2
FPF (Fins perfoot)	228	216	216	216	204	204
Fin Side Area	m ² 0,8	1,01	1,67	1,67	2,24	2,97 3,33
Condensing Fan						
Quantity	1	1	1	1	2	1 1
Propellerdiameter	mm 22"	26"	30"	30"	26"	35" 35"
Air Flow	m ³ /h 7234	9180	11900	11900	18360	23800 30600
Pipe Diameters						
Numberof Circuits	1	1	1	2	1	2 1 2 1 2
Liquid Line	in. 1/2"	1/2"	5/8"	1/2"	7/8"	1/2" 7/8" 5/8" 11/8" 5/8"
Suction Line	in. 7/8"	11/8"	13/8"	7/8"	15/8"	11/8" 15/8" 13/8" 2 1/8" 13/8"
Equipment Weight	kg 108	127	198	196	335	275 355 359 360 368

Tab. 03 - Dados gerais unidade condensadora TRCE050 a 150 (60Hz)

Model	050	075	100	150
Nom inal Cap.	Ton 5	7,5	10	15
Dimensions				
Width	mm 993	1217	1491	1712
Depth	mm 560	560	560	560
Height	mm 1393	1494	1 545	1849
Compressor				
Type	Scroll	Scro ll	Scroll	Scroll
Qty/Ton	Ton 1/5	1/7,5	1/10 2/5	1/15 2/7,5
Condensing Coil				
Rows	4	4	4	4
FPF (Fin pe r Feet)	ft 144	144	144	144
Fin Side Area	m ² 0,55	0,83	0,99	1,72
Quantity	1	1	1	1
Condensing Fan				
Motor	CV 1,5	3	4	5
N° Phases	3	3	3	3
Motor Rotation / No of Poles	RPM 1700 / 4	1710 / 4	1720 / 4	1730 /4
Air Flow	m ³ /h 5500	8250	9950	15750
Equipment Weigth	kg 184	2 1 0	305 310	400 400

Note:

(1) RLA = Rated Amps - 220V / 60 Hz. (2) FLA = Full Load Amps - 220V / 60 HZ (3) Voltagem variation: +/- 10%

Unit Inspection

Unit Inspection

After the unit is delivered at the job site:

- Verify that the nameplate data matches the data on the sales order, invoice and shipping documents (including electrical data).
- Verify that the power supply matches the unit nameplate specifications.
- Inspect the unit carefully for any shipping damage.

If any damage or material shortage is found it must be reported immediately to the carrier. Specify the type and extent of the damage on the carrier's delivery receipt before signing.

- Notify Trane and/or the contractor about the damages and actions to repair the unit. Do not attempt to repair the unit until the damages are inspected.

Storage

If it is not possible to install the unit after delivery, it should be stored in a safe location, protected from the weather and other damages. Improper equipment storage or handling will void the equipment warranty.

Instructions for proper installation

Please consider the following items required for proper installation before placing the unit at the mounting location:

- The mechanical room should be provided with proper lighting for servicing and maintenance.

- Make sure that the floor or foundation is levelled, solid, and sufficient to support the unit and accessory weights. Level or repair the floor before positioning the unit.

- Provide the units with rubber pads or vibration isolators.

- Install the hydraulic components required to drain the water from the condensate tray.

- Allow minimum recommended clearances for routine maintenance and service (see page 20).

- The same clearances should be observed in case of several units together or condensing units.

- Provide electrical installation. The unit has electrical inputs on both sides.

- Provide enough clearance to access piping and remove covers.

The power supply must comply with local codes and/or NEC.

- The contractor should provide and install the refrigeration piping - both for the liquid line and the suction line - in order to interconnect evaporator and condensing units.

General Safety

The Trane equipment is designed for safe and reliable operation, as long as units are operated according to

the applicable safety rules. The system uses electrical and mechanical parts, as well as gas pressures, that may injure people or damage the equipment if safety rules are not followed. Therefore, the installation, start-up and maintenance of this equipment must be performed only by qualified personnel or personnel approved by Trane. Follow all safety standards related to the task and warnings on unit labels, and always use proper tools and equipment.

Hazard Identification



WARNING!

Warnings appear at appropriate intervals and sections throughout this manual to warn operators and service personnel about a potentially hazardous situation which **MAY** result in serious injury or equipment damage if safety rules are not met.



CAUTION:

Cautions appear at appropriate intervals and sections throughout this manual to warn operators and service personnel about a potentially hazardous situation which may result in damage to the equipment and/or environment.

Transport and Handling

Fig. 01 - Transport and Handling Instructions.

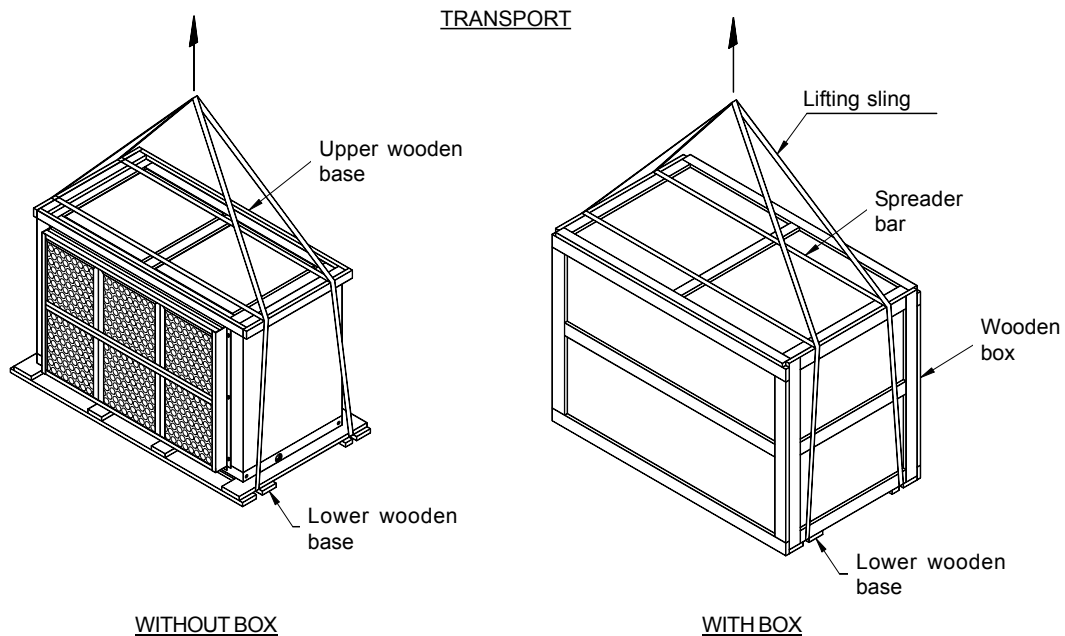

WARNING!

The lifting equipment capacity must exceed the unit weight by a proper safety factor in order to avoid death or equipment damage.



WARNING!

Each of the cables, chains or slings used to lift the unit must be capable of supporting the entire weight of the unit.

Handling and Displacement Instructions

Proceed as follows to transport and handle the unit:

1. Check the manual or nameplate for the actual equipment weight.
2. For all units, place lifting cables or chains under the skid. Other lifting methods may cause serious injuries or equipment damage.
3. Do not allow chains, slings or steel cables to touch the unit in order to avoid damages or accidents. Use suitable spreader bars as shown in the figure.

4. The module packaging material should only be removed after the unit is placed at the final mounting location. Take proper care while handling the equipment.

5. During transportation, do not swing the unit more than 15° (fifteen grades) in relation to the vertical position.

6. Always test-lift the unit to ensure proper balance and stability before lifting the unit to the mounting location.

7. For horizontal displacement, use rollers of equal diameter under the wooden base.

Installation Procedures

Installation Checklist

Complete this checklist after installing the unit to verify that all recommended installation procedures are complete before start-up.

This checklist does not replace the detailed instructions in the appropriate sections of this manual. Always read the entire section carefully to become familiar with the procedures.



WARNING!

Disconnect the power supply to avoid injuries or death caused by electrical shock.

Receiving

- The unit and parts have been inspected to check for shipping damages.
- The unit has been checked for missing controls and materials.
- The nameplate data matches the order data.

Unit Location

- The unit package has been removed from the unit. Do not remove the skid until the unit is at its final location.
- The unit location is appropriate for the size of the unit and all air ducts, refrigeration pipings and electrical ducts.
- There are proper access and maintenance clearances provided around the unit.

Unit Handling

- Proceed according to instructions on of this manual.

Unit Installation

- The unit is located at its final position.
- The skid and screws have been removed.
- The unit is properly installed and the drain slope is correct.
- Rubber pads or isolators are properly adjusted (if installed).
- Compressor pad screws have been re-tightened.

Component Review

- Fan and motor shafts are parallel.
- Fan and motor sheaves are aligned.
- The fan belt tension is correct. Rotors can be freely turned.
- Locking screws, bearing screws and sheaves are tightened.
- Bearings do not oscillate when turned.

Air Ducts

- The unit return duct (if used) is secured and at least 8 cm of flexible duct or canvas are available.
- The air supply duct must not be changed or reduced, and its direction must not be altered. The distance to the air supply discharge should be at least three times the duct diameter. Place at least 8 cm of flexible duct or canvas.

- The main duct is connected to terminal units and there are no leaks.
- All ducts comply with standards or codes.

Refrigerant Piping

- Siphons have been installed in the suction line, if required.
- Pipings have been leak-tested.
- Refrigerant pipings are not touching any other objects.

Controls

- The control thermostat is properly installed in an area away from lamp heat, warm or cold air flows, direct sun light and not behind any doors.

Wiring Diagrams

- Check the wiring diagram on the internal cover of the electrical panel.
- Power is supplied to the AC unit by disconnecting switches or circuit breakers.
- Verify that all electrical terminals are re-tighten.
- Check phase sequencing and unit connections.

Refrigeration Piping (Interconnection)

Refrigerant Piping

Units should be interconnected preferably by copper pipes.

The Table 04 presents connection sizes for Onix units and remote TRCE/TRAE condensing units, as well as liquid and suction piping sizes recommended for the interconnection.

The equivalent lengths indicated already include losses due to valves, curves, elbows, reductions, etc.

Maximum Distances (Recommended)*

Distance between units: **46m**

Difference between unit levels: **18m**

(*) – Calculated distance, considering equivalent length of connection elements.

Contact **Trane** for distances above the recommended ones.

Tab. 04 - Connection and Pipe Sizes Recommended by Circuit.

Line(Ton)	Connection Size (in.)				Equivalent Pipe Length													
	CXS Mod.		TRCE/TRAE		<12m		12~18m		18~24m		24~30m		30~36m		36~46m			
	Liq.	Suct.	Liq.	Suct.	Liq.	Suct.	Liq.	Suct.	Liq.	Suct.	Liq.	Suct.	Liq.	Suct.	Liq.	Suct.		
5	1/2	7/8	1/2	7/8	1/2	7/8	1/2	7/8	1/2	7/8	1/2	7/8	1/2	7/8	1/2	7/8	1-1/8	
7,5	5/8	1-1/8	1/2	1-1/8	1/2	7/8	1/2	7/8	1/2	1-1/8	5/8	1-1/8	5/8	1-1/8	5/8	1-1/8	7/8	1-3/8
10	5/8	1-3/8	5/8	1-3/8	5/8	1-1/8	5/8	1-1/8	5/8	1-1/8	7/8	1-3/8	7/8	1-3/8	7/8	1-3/8	7/8	1-3/8
12,5	5/8	1-3/8	5/8	1-3/8	5/8	1-1/8	7/8	1-3/8	5/8	1-5/8	7/8	1-5/8	7/8	1-5/8	7/8	1-5/8	7/8	1-5/8
15	5/8	1-5/8	7/8	1-3/8	5/8	1-3/8	7/8	1-3/8	7/8	1-3/8	7/8	1-5/8	7/8	1-5/8	7/8	1-5/8	7/8	1-5/8
20	5/8	1-5/8	1 1/8	1-5/8	7/8	1-3/8	7/8	1-5/8	7/8	1-5/8	7/8	1-5/8	7/8	1-5/8	7/8	1-5/8	1-1/8	2-1/8
25	7/8	2-1/8	1 1/8	1-5/8	7/8	1-3/8	7/8	1-5/8	7/8	1-5/8	1-1/8	2-1/8	1-1/8	2-1/8	1-1/8	2-1/8	1-1/8	2-1/8

Note: For equivalent lengths above the values indicated, please contact Trane or an authorized installer.

Instructions for Fixing the Expansion Valve Thermostatic Bulb

- In the suction line, as closest as possible to the evaporator outlet.
- Before external equalization, in an horizontal line run.

- The copper tube must be completely clean.
- At the 12h position for pipes smaller than 7/8", and 4h or 8h position for 7/8" or larger pipes.
- Then insulate the pipes using thermal sheets.

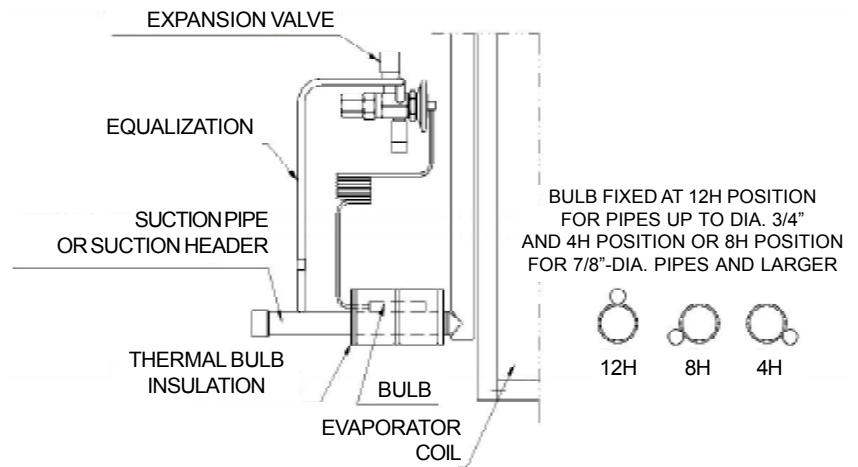

CAUTION:

Do not operate the unit without air filters.

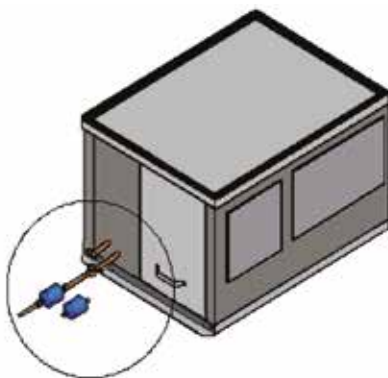

MOUNTING DIAGRAM
DRIER FILTER

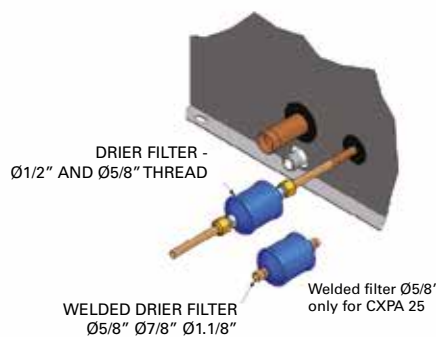

MOUNTING DIAGRAM
DRIER FILTER AND LIQUID SIGHT GLASS

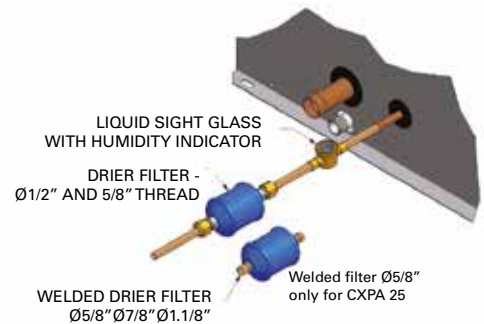

Refrigerating Tubing - Interconnection

TRAE/TRCE

Refrigerant Piping

Units should be interconnected with copper pipes.

Connection gauges of evaporating units and remote condensing units TRAE or TRCE, and suction and liquid piping gauges recommended for interconnecting both are indicated on Table 04.

The corresponding lengths already include losses generated by valves, curves, elbows, reductions, etc.

Maximum distance (recommended)*

distance between units: **46 m**.

difference in levels between units: **18 m**.

(*) – Calculated distance, considering equivalent length of connection elements.

For distances higher than the recommended value, please contact **Trane**.

Evaporating Unit above the Condensing Unit

- Build a 20 cm inverted siphon in the suction line at the evaporating unit outlet, after the regular oil accumulation siphon.

- Horizontal sections in the suction line should be inclined by 45 mm at every 10 m of line towards condensing unit.

Condensing Unit above the Evaporating Unit

- Build a 10 cm siphon at rising and a siphon at every 7.5 m of vertical line.

- Horizontal sections in the suction line should be inclined by 45 mm at every 10 m of line towards condensing unit.

Fig. IV-01 - Assembly Evaporating Unit over Condensing Unit.

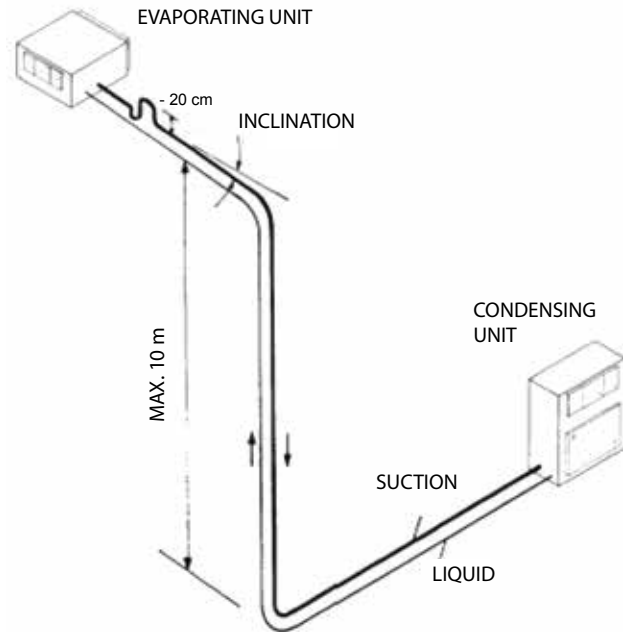
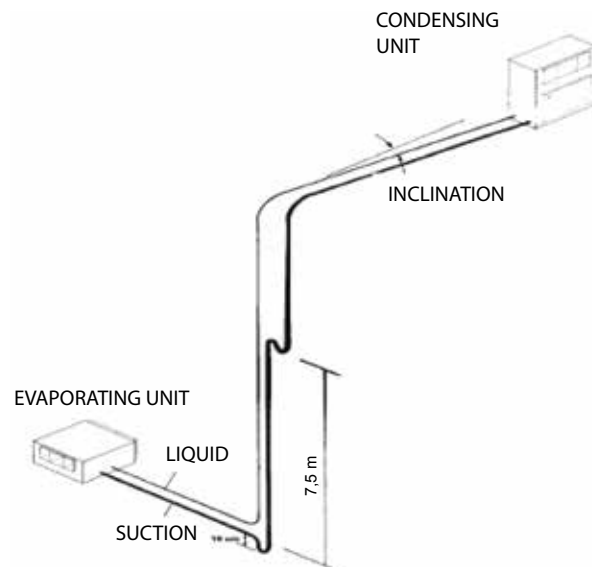

Fig. IV-02 - Assembly Condensing Unit over Evaporating Unit.



Maintenance Procedures

Maintenance Procedures

These sections describe maintenance procedures to be performed as part of the normal unit maintenance program.

Air Filters

The washable permanent filters provided with the AC units should be cleaned using a solution of water and neutral detergent.

Put the filters into the solution, brush them, flush with cold water and then apply a compressed air jet.

Replace throwaway filters.

Do not operate the unit without filters.

Sheaves and Belts

Check if the sheaves are properly aligned and operating correctly.

1. Turn the sheaves with the hand in order to check if they can move freely.
2. Check motor and fan shafts. Both shafts should be parallel to each other.
3. Verify that fan and motor sheaves are aligned. In case of sheaves with different widths, align sheave centers, as shown in Fig. 2.
4. Make sure the belt tension is correct. This will increase the life of motor and fan bearings.

Tab. 05 - Nominal load of refrigerant R410a and oil load - Condensing Units + Onix

Indoor	Outdoor	R410a(kg)		Oil(L)	
		Ckt1	Ckt2	Ckt1	Ckt2
CXPA050 1C	TRAE050 1C	2,99		1,57	
CXPA075 1C	TRAE075 1C	3,40		3	
CXPA100 1C	TRAE100 1C	5,95		3,3	
CXPA100 2C	TRAE100 2C	2,99	2,99	1,57	1,57
CXPA125 2C	TRAE 075 + TRAE 050	4,59	2,99	3	1,57
CXPA150 1C	TRAE150 1C	8,76		3,6	
CXPA150 2C	TRAE150 2C	4,59	4,59	3	3
CXPA200 1C	TRAE200 1C	10,46		6,7	
CXPA200 2C	TRAE200 2C	7,07	7,07	3,3	3,3
CXPA250 1C	TRAE250 1C	13,01		6,7	
CXPA250 2C	TRAE250 2C	7,07	7,07	3,3	3,3
CXPA300 2C	TRAE150 1C + TRAE150 1C	8,76	8,76	3,6	3,6
CXPA350 2C	TRAE200 1C + TRAE150 1C	10,46	8,76	6,7	3,6
CXPA400 2C	TRAE200 1C + TRAE200 1C	10,46	10,46	6,7	6,7
CXPA500 2C	TRAE250 1C + TRAE250 1C	13,01	13,01	6,7	6,7
CXPA050 1C	TRCE050 1C	1,36		1,57	
CXPA075 1C	TRCE075 1C	2,08		3	
CXPA100 1C	TRCE100 1C	2,72		3,3	
CXPA100 2C	TRCE100 2C	1,36	1,36	1,57	1,57
CXPA125 2C	TRCE 075 + TRCE 050	2,08	1,36	3	1,57
CXPA150 1C	TRCE150 1C	4,17		3,6	
CXPA150 2C	TRCE150 2C	2,08	2,08	3	3
CXPA200 2C	TRCE100 1C + TRCE100 1C	2,72	2,72	3,3	3,3
CXPA250 2C	TRCE150 1C + TRCE100 1C	4,17	2,72	3,6	3
CXPA300 2C	TRCE150 1C + TRCE150 1C	4,17	4,17	3,6	3,6



CAUTION:

Do not operate the unit without air filters.

Fig. 06 - Belt Alignment

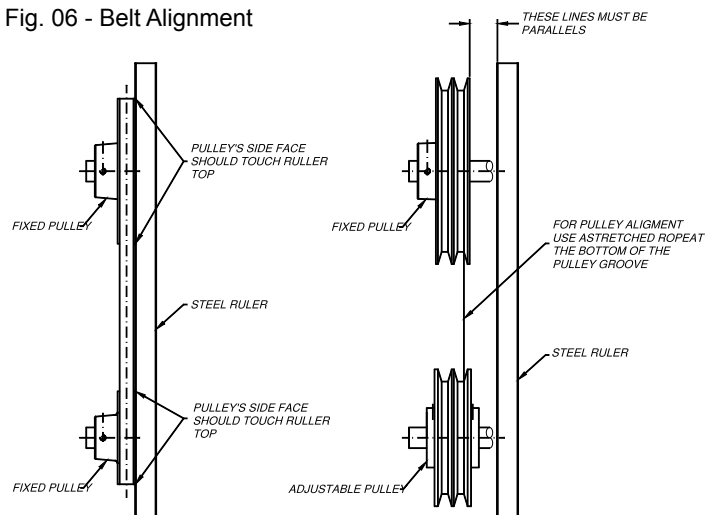

Maintenance Procedures

Unbalanced Voltage

An excessive unbalance between phases in a 3-phase system will lead to motor overheating and failures.

The maximum allowable unbalance is 2%. Voltage unbalance can be defined as 100 times the maximum offset of the three voltages (i.e. three phases) minus the average (regardless of the sign), divided by the average.

Example:

If the three voltages measured in a line are 221 V, 230 V and 227 V, the average will be:

$$(221 + 230 + 227)/3 = 226 \text{ volts}$$

The unbalance percentage is:

$$100 \times (226 - 221)/226 = 2.2\%$$

This result indicates the presence of an unbalance above the maximum allowable value of 0.2%. The phase unbalance can result in a current unbalance of 20%, leading to an increase in motor winding temperature and reducing motor life.

Fig. 07 - Belt Tension Meter

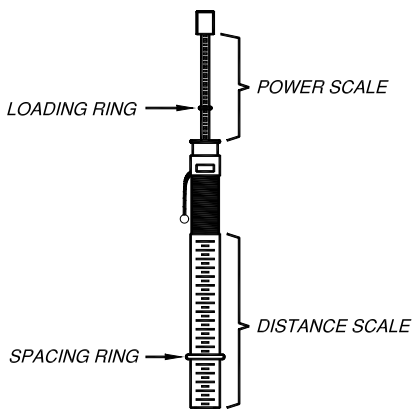

Belt Tension Measurement

A tension meter such as the one showed in Fig. 3 will be required to measure the belt tension. The proper deflection is determined by the result of the division of the distance between sheaves by 64 (inches). If a tension meter is not available, press the belt with the thumb. The belt should present a deflection of approx. 10 mm. If replacement for a new one is required, set tension to the belts and allow them to work for several hours until they adapt to the sheave channels, then set tension again.

Liquid Sight Glass

When the sight glass displays bubbles, one or more of the following problems may be present:

- Lack of refrigerant.
- Clogged drier filter.
- Expansion valve is too open.
- Low subcooling.
- Presence of non-condensables.

A yellow color indicates the presence of residual humidity in the refrigerant circuit.

During normal operation the sight glass display should be green with no bubbles, indicating that the refrigerant load in the refrigeration circuit is correct and that the refrigerant is dehydrated.

Condenser Coil

The condenser coil should be cleaned with a soft brush and compressed air jets or low pressure water jets in the opposite direction of normal air flow. Move the hose vertically and adjust the hose pressure so that it doesn't damage the fins.



CAUTION:

Do not crush the fins during the cleaning process. This will reduce the heat exchange.

Fig. 08 - Belt Tension Adjustment

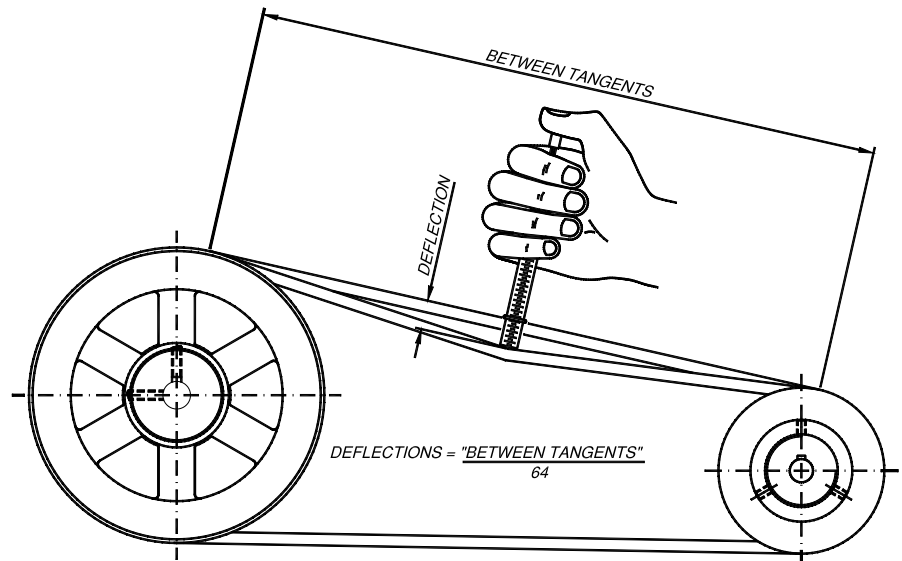

Periodical Preventive Maintenance

Preventive Maintenance

IMPORTANT

Perform all inspections and maintenance services at the recommended intervals. This will increase equipment life and reduce possible equipment failures.

Record operation conditions for this unit monthly. The operation datasheet can be a precious diagnostic tool for service personnel. By noticing trends in operating conditions the operator can often anticipate and prevent problem situations before they become serious.

If the unit is not operating properly, refer to the section on abnormal conditions at the end of this manual.

Weekly Maintenance

When the equipment is operating for approx. 30 minutes and the system is stable, check the operating conditions and perform the following checking procedures:

- Clean permanent air filters more regularly, depending on the job site.

Monthly Maintenance

- Clean the permanent air filter. Throwaway filters should be replaced.
- Check fan belt tension, alignment and condition.
- Clean the fan volute.
- Re-tighten all terminal screws.
- Clean the evaporator tray, the hose and the condensate water drain.
- Check the liquid line sight glass. Leak-test and repair, if required.

- When the liquid sight glass and the operational conditions indicate lack of gas, measure the system superheating and subcooling.
- When operational conditions indicate overload, remove the refrigerant slowly (to minimize oil losses) through the Schrader service valve in the liquid line.
- Inspect the system to detect abnormal conditions. Use a reading sheet to record unit conditions. A reading sheet can be a precious tool for service personnel.

Quarterly Maintenance

- Perform all monthly maintenance tasks.
- Check bearing and shave fixing screws and adjust then, if required.
- Clean the condenser more often, depending on the job site.
- Clean the evaporator more often, depending on the job site.
- Check and write down fan motor and compressor operation voltages and currents.
- Test safety controls.
- Check and write down evaporator entering and leaving dry bulb and wet bulb temperatures.
- Check suction and discharge pressures with the manifold.
- Measure and record the system superheating.
- Measure and record the system subcooling.

Annual Maintenance

- Perform all recommended monthly and quarterly maintenance tasks.
- Have a qualified technician to check the adjustment and opera-

tion of each control, and inspect and replace contactors or controls, if required.

- Remove the cabinet panels and remove rust spots.
- Replace the thermal insulation and defective gaskets.
- Repair the external and internal painting, if required.
- Remove rust.
- Inspect and clean the condenser pipes, if required.
- Inspect the expansion valve bulb. Clean it, if required. The contact between the bulb and the suction line should be excellent, and the bulb should be properly insulated.
- Measure the electrical insulation of the compressor motor.

IMPORTANT

Not Performing preventive maintenance tasks in the equipment may lead to impaired performance and even void the equipment warranty.

Motor Electrical Data

60Hz

Tab. 06 - Electrical Data - 4-Poles Motor Forward-Curved (60 Hz) - CXPA Evaporator Module

Motors Cap.	0,5	0,75	1	1,5	2	3	4	5	6	7,5	10	12,5	15	20	25	30	40
N Poles	4	4	4	4	4	4	4	4	4	4	4	4	4	4	4	4	4
Protection Level	IP21	IP21	IP21	IP21	IP21	IP21	IP55	IP55	IP55	IP55	IP55	IP55	IP55	IP55	IP55	IP55	IP55
Rated RPM	1730	1735	1720	1710	1710	1740	1715	1735	1740	1740	1760	1760	1760	1765	1765	1765	1770
Nom. Power (KW)	0,30	0,44	0,60	0,88	1,20	1,76	2,40	2,96	3,60	4,40	6,00	7,36	8,80	12,00	14,80	17,60	24,00
Max. Power (KW)	0,37	0,55	0,75	1,10	1,50	2,20	3,00	3,70	4,50	5,50	7,50	9,20	11,00	15,00	18,50	22,00	30,00
220 V	CNO (A)	1,54	2,26	2,84	3,85	5,18	7,94	8,88	10,96	13,20	16,16	20,64	25,12	29,76	42,08	51,68	59,20
	CMO (A)	1,92	2,82	3,55	4,81	6,48	9,93	11,10	13,70	16,50	20,20	25,80	31,40	37,20	52,60	64,60	74,00
	CRT (A)	9,62	15,00	19,20	27,42	37,58	77,45	71,04	109,60	102,30	127,26	203,82	251,20	305,04	357,68	439,28	473,60
380 V	CNO (A)	0,89	1,30	1,64	2,22	2,99	4,58	5,12	6,32	7,62	9,32	11,91	14,49	17,17	24,28	29,82	34,16
	CMO (A)	1,11	1,63	2,05	2,78	3,74	5,73	6,40	7,90	9,52	11,66	14,89	18,12	21,46	30,35	37,27	42,70
	CRT (A)	5,55	8,66	11,08	15,82	21,69	44,69	40,99	63,24	59,03	73,43	117,60	144,94	176,01	206,38	253,46	273,27
440 V	CNO (A)	0,77	1,13	1,42	1,92	2,59	3,97	4,44	5,48	6,60	8,08	10,32	12,56	14,88	21,04	25,84	29,60
	CMO (A)	0,96	1,41	1,78	2,41	3,24	4,97	5,55	6,85	8,25	10,10	12,90	15,70	18,60	26,30	32,30	37,00
	CRT (A)	4,81	7,50	9,60	13,71	18,79	38,73	35,52	54,80	51,15	63,63	101,91	125,60	152,52	178,84	219,64	
460 V	CNO (A)	0,73	1,08	1,36	1,84	2,48	3,80	4,25	5,24	6,31	7,73	9,87	12,01	14,23	20,13	24,72	28,31
	CMO (A)	0,92	1,35	1,70	2,30	3,10	4,75	5,31	6,55	7,89	9,66	12,34	15,02	17,79	25,16	30,90	35,39
	CRT (A)	4,60	7,17	9,18	13,11	17,97	37,04	33,98	52,42	48,93	60,86	97,48	120,14	145,89	171,06	210,09	

Tab. 07 - Electrical Data - Compressor Module

Nominal capacity	Kw (Nominal)			Kw (Maximum)			RLA			FLA			LRA		
	220V / 380V / 440V	220V / 380V / 440V	220V / 380V / 440V	220	380	440	220	380	440	220	380	440	220	380	440
5	5,7	7,18	16,8	11,0	7,9	20,5	13,2	9,5	170,0	96,0	82,0				
7,5	8,57	10,83	26,2	16,3	13,2	31,6	19,7	15,9	203,0	124,0	98,0				
10	9,96	12,51	31,3	19,0	15,3	37,5	22,8	18,3	267,0	160,0	142,0				
12,5	12,94	16,22	38,8	23,8	19,0	46,8	28,8	22,9	304,0	168,0	147,0				
15	16,45	20,45	50,0	29,8	25,0	59,8	35,7	29,9	351,0	239,0	197,0				
20	22,56	28,18	74,6	40,9	31,2	86,5	49,5	38,6	485,0	260,0	215,0				
25	27,21	34,29	81,3	48,7	39,2	98,7	59,6	48,0	560,0	310,0	260,0				

Note:

- (1) RLA = Rated Load Amps (A) - 220 V / 60 Hz.
- (2) FLA = Full Load Amps (A) - 220 V / 60 Hz.
- (3) LRA = Locked Rotor Amps (A) - 220V / 60 Hz.
- (4) Voltage variation: +/- 10%

Tab. 08 - Motors and Condensers Electrical Characteristics - TRAE (60 Hz)

Motors Capacity (cv)	Single-phase - IP21			CNO			CMO			CRT		
	N. Polos	rpm	kW	220	440	220	440	220	440	220	440	
0,25	8	800	0,18	1,8	-	1,79	-	3,4	-	-	-	
0,75	8	800	0,55	4,3	-	4,3	-	12,9	-	6	-	
1	8	800	0,75	4,9	-	4,9	-	14,20	-	6,70	-	

Electrical Data

Fig.09 - Crankcase Heater

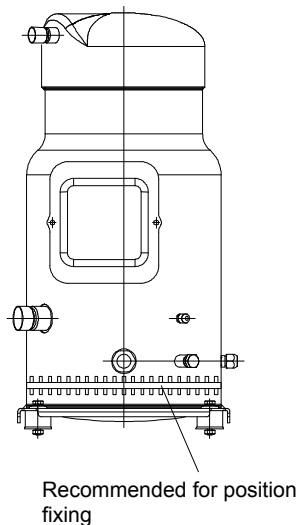

Crankcase Heater

Trane recommends the use of crankcase when the load of the system refrigerant load exceeds the refrigerant compressor limit (RCL). The needs of crankcase heater are directly related to the possibility of liquid migration to the compressor, and consequently causing poor lubrication of it. Migration can occur during long periods of compressor shutdown (over 8 hours). The crankcase heater is recommended to eliminate the liquid migration when these downtime long periods. The crankcase heater must be installed on the compressor housing and below the removal oil point. The crankcase heater must remain energized while the compressor is off.

This will prevent the dilution of oil and the bearings overload in the initial compressor starts. When the compressor is off, the crankcase



Attention:

The strength of crankcase must be energized at least 12 hours before the startup of the compressor (with the service valves open) and should be maintained until the compressor energized startup.

temperature should be kept at least 10°C above the refrigerant temperature in the suction side (low pressure side). This requirement ensures that the refrigerant will not be retained in the compressor crankcase. Tests can be done to ensure that the appropriate temperature of the oil is maintained below the ambient conditions (temperature and wind). Therefore, for a temperature below -5°C and an over 5m/s wind speed, it is recommended that the resistors be thermally isolated to limit the energy loss to the environment.

Tab. 08 - Crankcase Heaters

Crankcase Heater									
Power W	Voltage V	Trane Code X1314	Mnemonic Code	Quantity	Diameter (mm)		Length (mm)		
					min.	máx.	Conexion Cable	Resistance	Fixing Chape
70	240	X13140710-11	HTR00199B	1	185	210	520	460	60
	480	X13140710-12	HTR00200B	1	185	210	520	460	60
100	240	X13140712-05	HTR12361	1	230	290	460	740	60
	480	X13140712-08	HTR00002B	1	230	290	460	740	60
160	230	X13140712-11	HTR12523	2	300	375	560	890	60
	460	X13140712-14	HTR12525	2	300	375	560	890	60

Wiring Diagram

Fig. 10 - Wiring Diagram - Start - CXPA 050 to 500

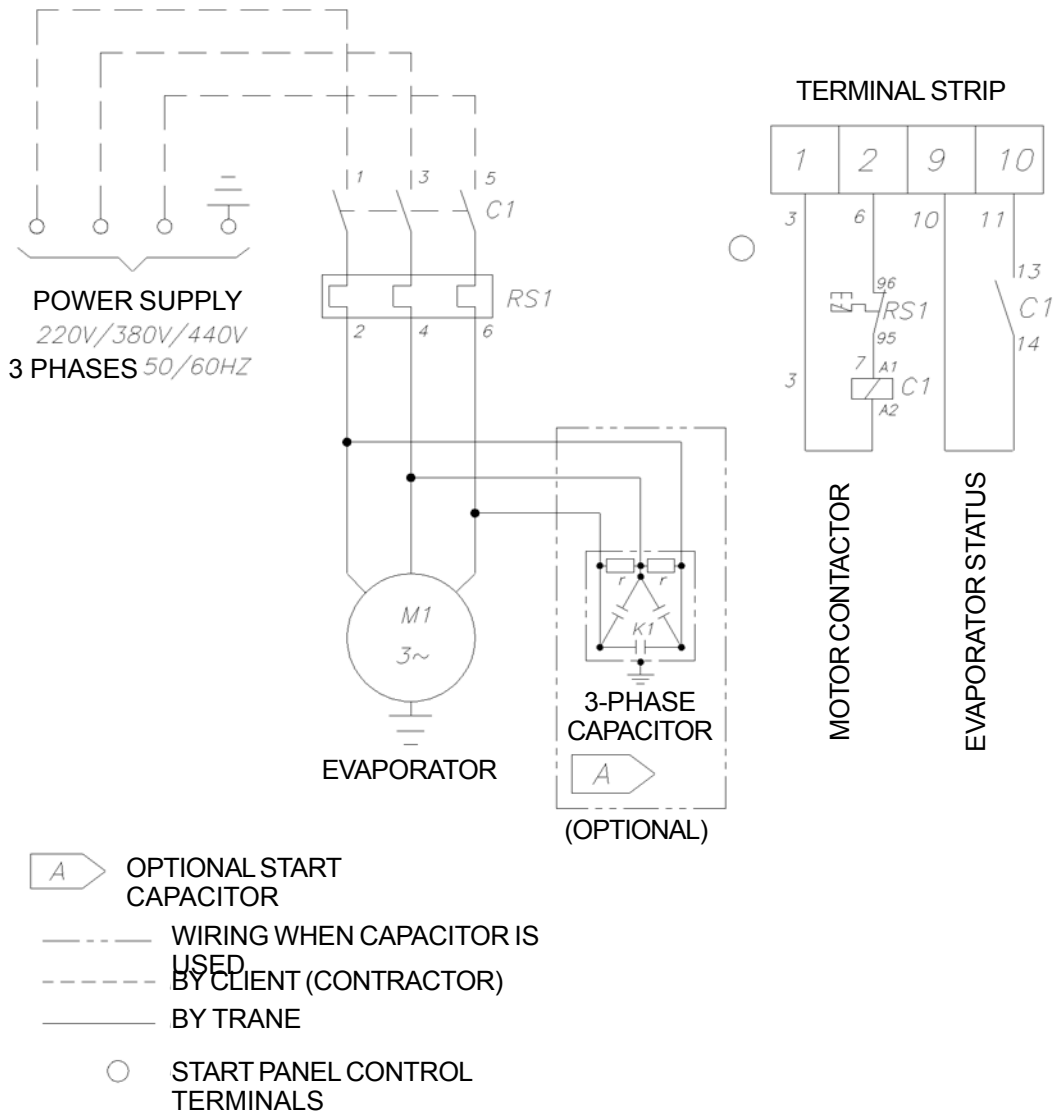

Dimensional Data

Fan/Coil

Fig. 11 - Dimensional Data - Fan Module - 050 to 100

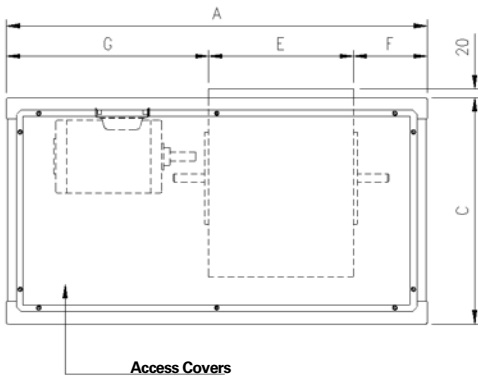

Model	050	075	100
A	950	1135	1420
B	485	565	660
C	510	590	690
D	290	341	403
B	326	386	473
C	167	224	373
D	457	525	574

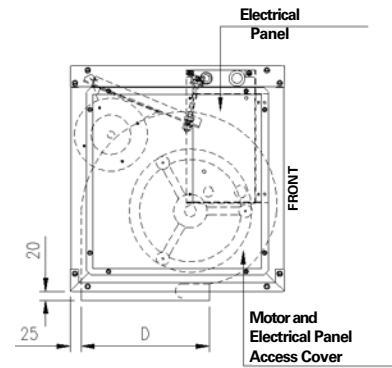
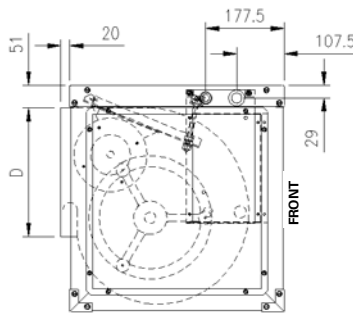
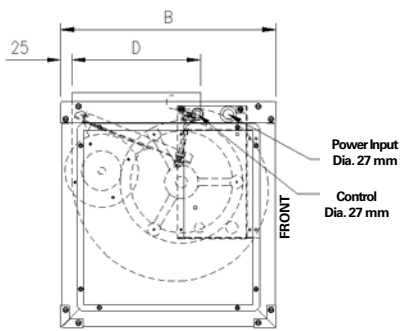

Fig. 12a - Vertical Discharge

Fig. 12b - Horizontal Discharge

Fig. 12c - Downflow Discharge

Unit: mm

Fig. 13 - Dimensional Data - Coil Module - 050 to 100

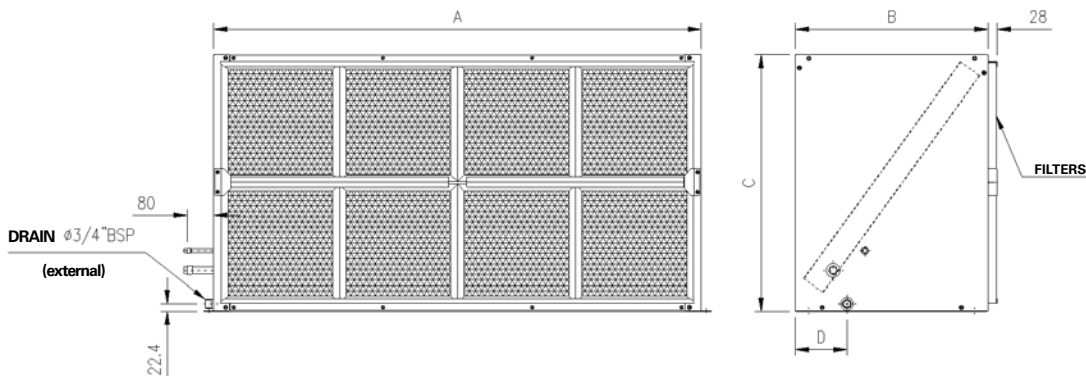

Modelo	050	075	100
A	950	1135	1420
B	485	565	660
C	510	590	585
D	140	140	245

Unit: mm

Dimensional Data

Fan/Coil

Fig. 14 - Dimensional Data - Fan Module - 125 and 150

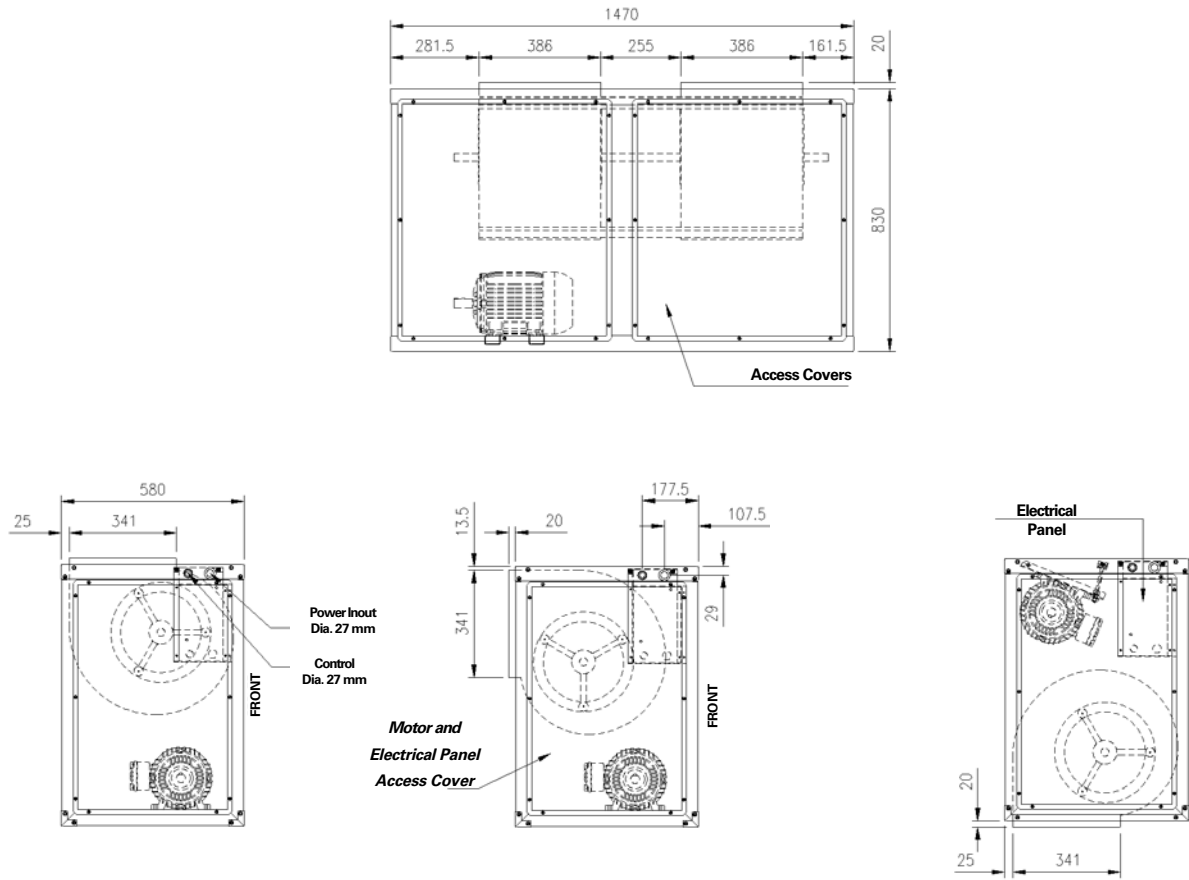
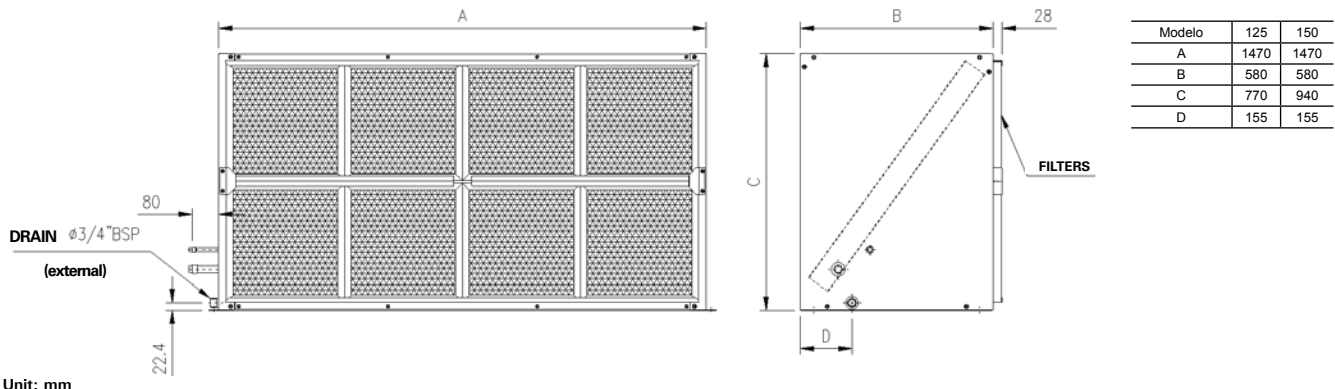

Fig. 15a - Vertical Discharge

Fig. 15b - Horizontal Discharge

Fig. 15c - Downflow Discharge

Fig. 16 - Dimensional Data - Coil Module - 125 and 150



Dimensional Data

Fan/Coil

Fig. 17 - Dimensional Data - Fan Module - 200 to 300

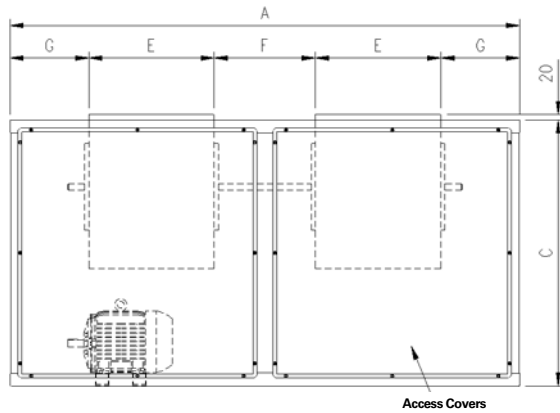

Dimensions - Fan Module

Model	200	250	300
A	1920	1870	2200
B	670	800	800
C	1000	1100	1100

Vertical Discharge

Model	200	250	300
D	402	480	480
E	473	428	556
F	381	457	457
G	296.5	278.5	315.5

Horizontal/Downflow Discharge

Model	200	250	300
E	478	433	561
F	376	452	452
G	294	276	313
H	407	485	485

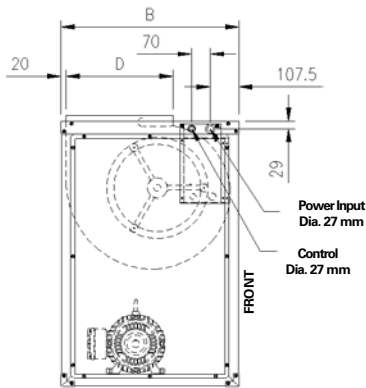

Fig. 18a - Vertical Discharge

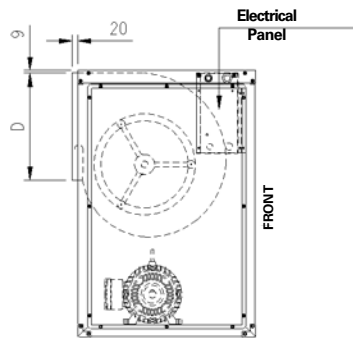

Fig. 18b - Horizontal Discharge

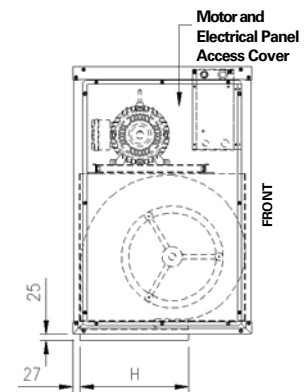
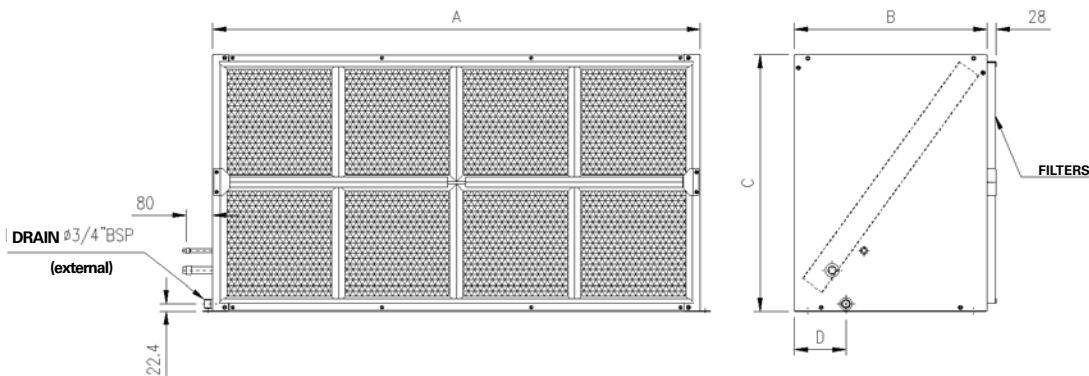

Fig. 18c - Downflow Discharge

Unit: mm

Fig. 19 - Dimensional Data - Coil Module - 200 to 300



Model	200	250	300
A	1920	1870	2200
B	670	800	800
C	880	1100	1100
D	140	140	140

Unit: mm

Dimensional Data

Fan/Coil

Fig. 20 - Dimensional Data - Fan Module - 350 to 500

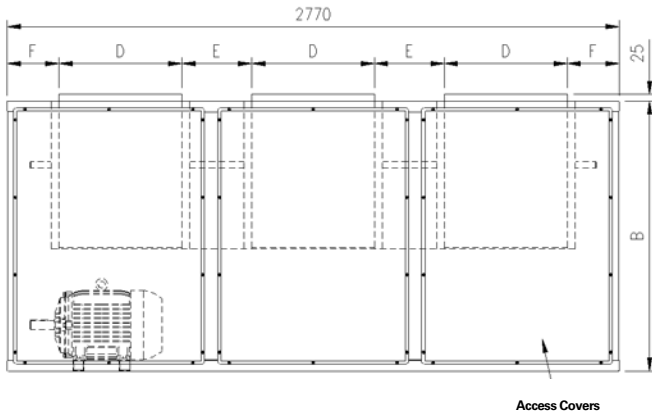

Dimensions - Fan Module

Model	350	400	500
A	800	900	900
B	1100	1220	1220

Vertical Discharge

Model	350	400	500
C	402	480	480
D	473	556	556
E	384	316	316
F	291.5	235	235

Horizontal/Downflow Discharge

Model	350	400	500
D	478	561	561
E	379	311	311
F	289	232.5	232.5
G	401	423	423
H	407	485	485

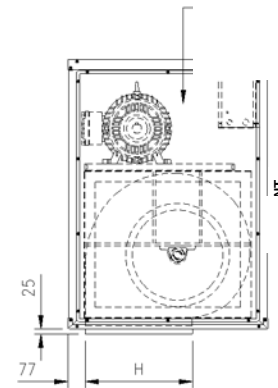
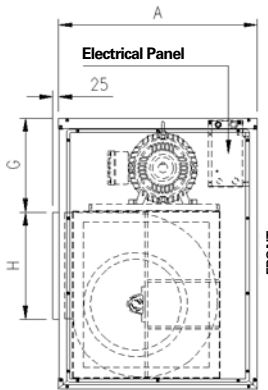
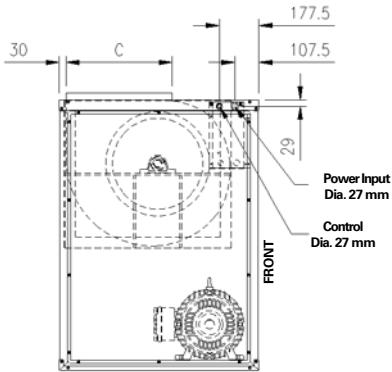

Fig. 21a - Vertical Discharge

Fig. 21b - Horizontal Discharge

Fig. 21c - Downflow Discharge

Unit: mm

Fig. 22 - Dimensional Data - Coil Module - 350 to 500

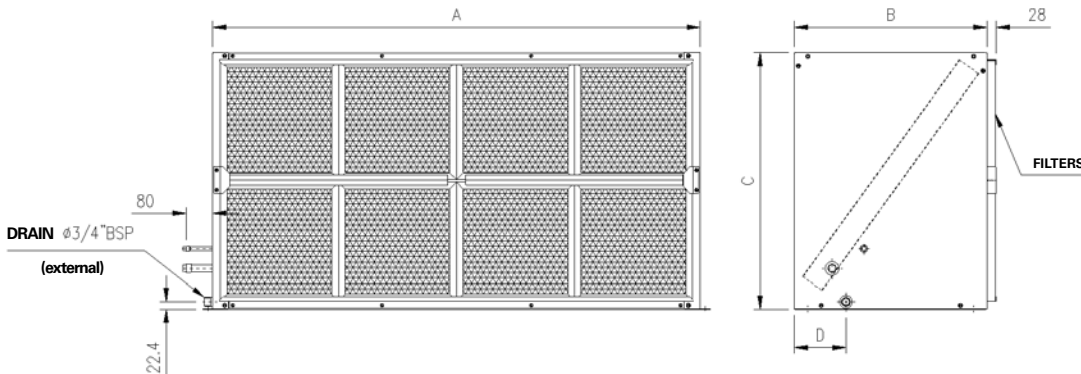

Model	350	400	500
A	2770	2770	2770
B	800	900	900
C	1100	1220	1490
D	140	140	140

Unit: mm

Dimensional Data

Coil Module (Refrigerant Circuits)

Fig. 23 - Coil Module Refrigerant Circuits - 050 to 500

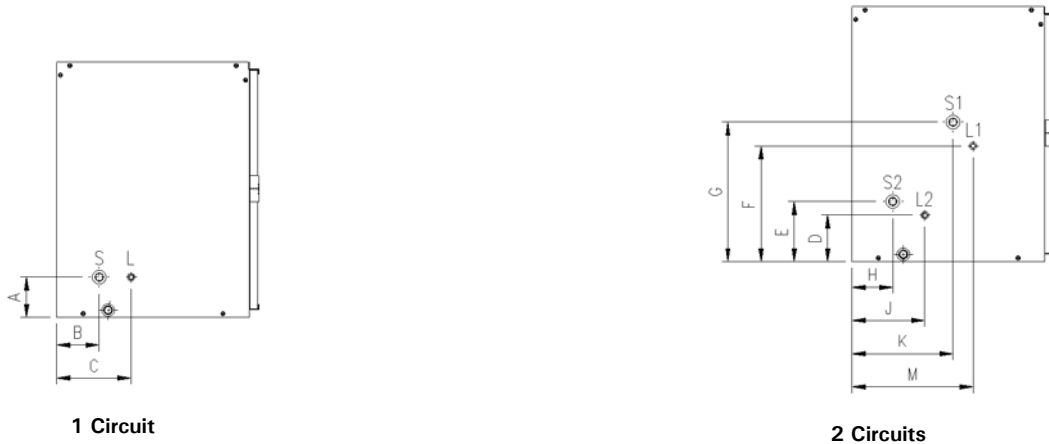

Tab. 09 - Connection Dimensions

Model	050	075	100	150	200	250
A	90	90	90	115	110	120
B	140	150	250	145	175	185
C	240	290	435	300	335	415

Tab. 11 - Connection Dimensions

Model	100	125	150	200	250	300	350	400	500
D	85	110	125	95	145	145	145	160	160
E	115	120	125	135	145	145	145	160	160
F	250	300	525	455	510	615	565	675	820
G	330	370	525	495	510	615	565	675	820
H	215	115	110	130	135	135	135	135	125
J	340	210	205	245	275	280	280	280	285
K	430	295	335	390	390	460	425	510	505
M	500	355	430	510	530	610	575	655	665

Tab. 10 - Connection Diameter

Model	050	075	100	150	200	250
Circuit (Ton)	05	7.5	10	15	20	25
S (Suction)	7/8"	1.1/8"	1.3/8"	1.5/8"	1.5/8"	2.1/8"
L (Liquid)	1/2"	1/2"	5/8"	7/8"	7/8"	1 1/8"

Tab. 12 - Connection Diameter

Model	100	125	150	200	250	300	350	400	500
Circuit 1 (Ton)	5	7.5	7.5	10	15	15	20	20	25
S1 (Suction)	7/8"	1.1/8"	1.1/8"	1.3/8"	1.5/8"	1.5/8"	1.5/8"	1.5/8"	2.1/8"
L1 (Liquid)	1/2"	1/2"	1/2"	5/8"	7/8"	7/8"	7/8"	7/8"	1.1/8"
Circuit 2 (Ton)	5	5	7.5	10	10	15	15	20	25
S2 (Suction)	7/8"	7/8"	1.1/8"	1.3/8"	1.3/8"	1.5/8"	1.5/8"	1.5/8"	2.1/8"
L2 (Liquid)	1/2"	1/2"	1/2"	5/8"	5/8"	7/8"	7/8"	7/8"	1.1/8"

Unit: mm

Unit: mm

Fig. 24 - Welding Procedures

IMPORTANT:

PROTECT SIDE AND RUBBER SLOT WITH A WET CLOTH DURING WELDING

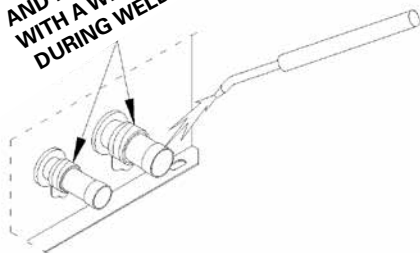

Dimensional Data

Module Assembly

Fig. 25 - Fan and Coil Module Assembly - CXPA 050 to 500 - Horizontal

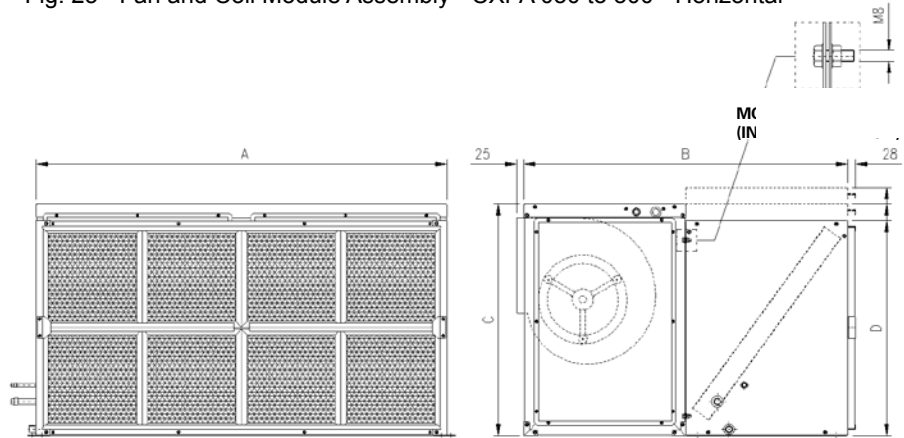

Model	050	075	100	125	150	200	250	300	350	400	500
A	950	1135	1420	1470	1470	1920	1870	2200	2770	2770	2770
B	970	1130	1320	1160	1160	1340	1600	1600	1600	1800	1800
C	510	590	690	830	830	1000	1100	1100	1100	1220	1220
D	510	590	585	770	940	880	1100	1100	1100	1220	1490

Fig. 26 - Fan and Coil Module Assembly - CXPA 050 to 500 - Horizontal - Superior View

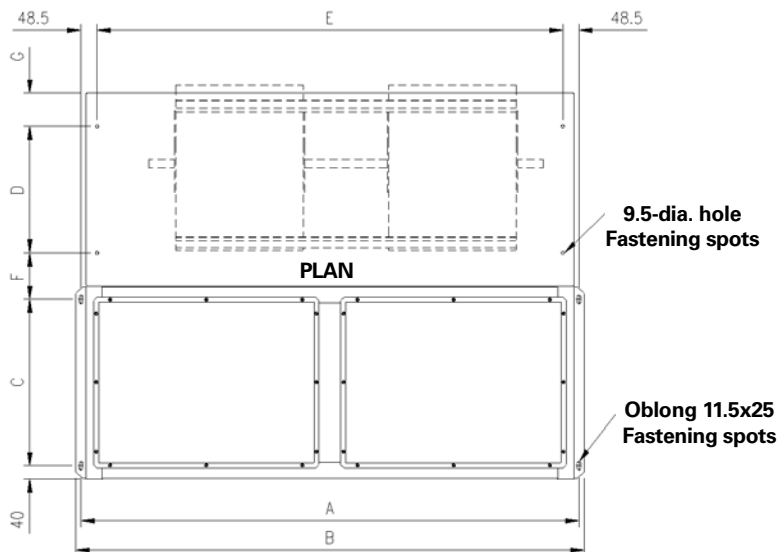

Model	050	075	100	125	150	200	250	300	350	400	500
A	980	1165	1450	1500	1500	1950	1900	2230	2800	2800	2800
B	405	485	580	500	500	590	720	720	720	820	820
C	1010	1195	1480	1530	1530	1980	1930	2260	2830	2830	2830
D	285	365	460	380	380	470	600	600	600	700	700
E	883	1068	1353	1403	1403	1853	1803	2133	2703	2703	2703
F	140	140	140	190	190	190	190	190	190	190	190
G	100	100	100	150	150	150	150	150	150	150	150

Dimensional Data

Module Assembly Details

Fig. 27 - Fan and Coil Module Assembly - CXPA 050 to 500 - Vertical

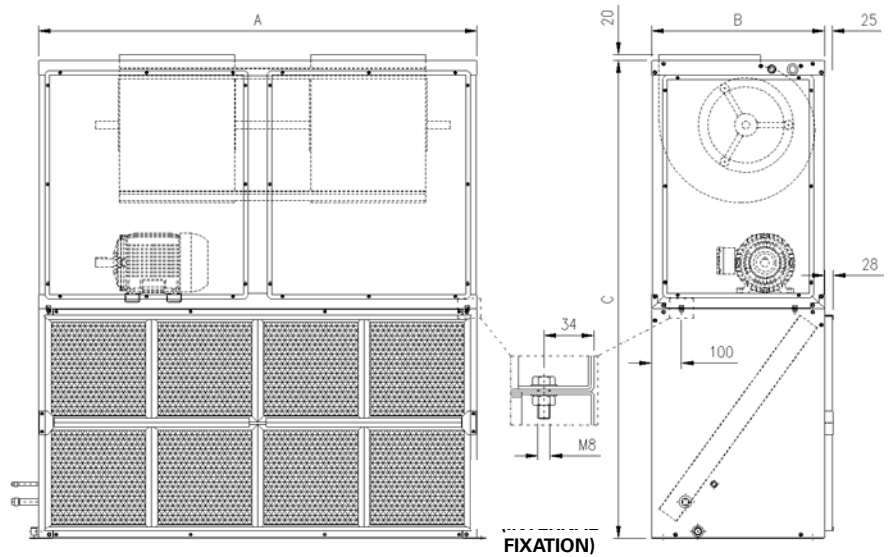

Modelo	050	075	100	125	150	200	250	300	350	400	500
A	950	1135	1420	1470	1470	1920	1870	2200	2770	2770	2770
B	485	565	660	580	580	670	800	800	800	900	900
C	1020	1180	1275	1600	1770	2100	2200	2200	2200	2440	2710
D	370	470	470	520	570	620	720	720	720	770	820
E	885	1035	1130	110	1150	1290	1520	1520	1520	1670	1720

Fig. 28 - Fan and Coil Module Assembly - CXPA 050 to 500 - Vertical - Superior View

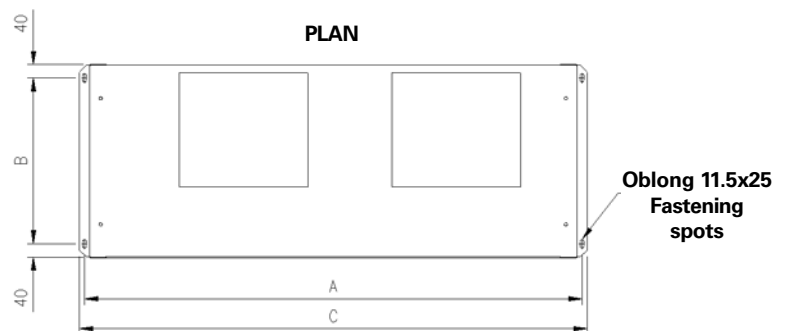

Modelo	050	075	100	125	150	200	250	300	350	400	500
A	980	1165	1450	1500	1500	1950	1900	2230	2800	2800	2800
B	405	485	580	500	500	590	720	720	720	820	820
C	1010	1195	1480	1530	1530	1980	1930	2260	2830	2830	2830

Unit: mm

Dimensional Data

Considerations for Modules

Fig. 29 - Suggested Clearances for Maintenance and Air Circulation - Fan and Coil Modules - Vertical Cabinets

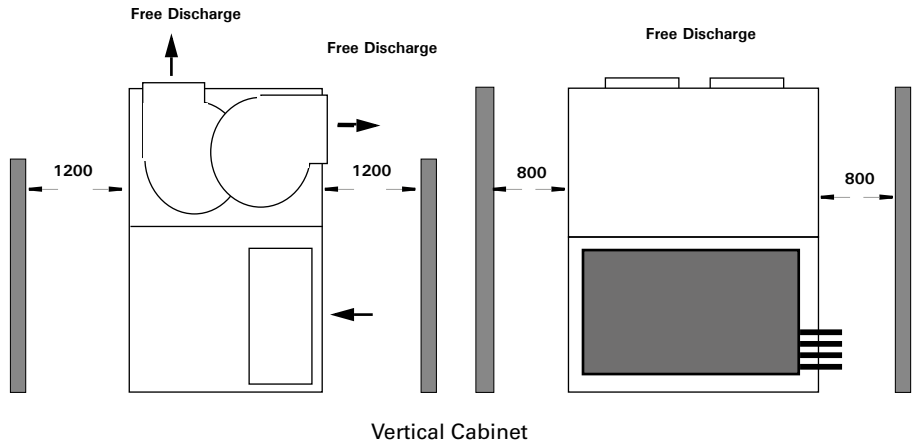
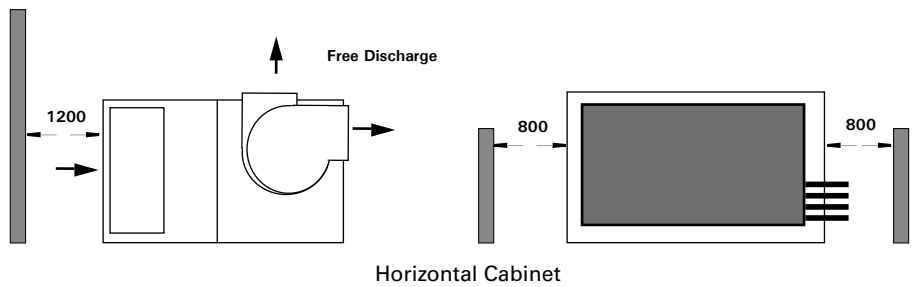

Fig. 30 - Suggested Clearances for Maintenance and Air Circulation - Fan and Coil Modules - Horizontal Cabinets



Dimensional Data

TRAE

Fig. 31 - Dimensions - Condensing Units TRAE 050

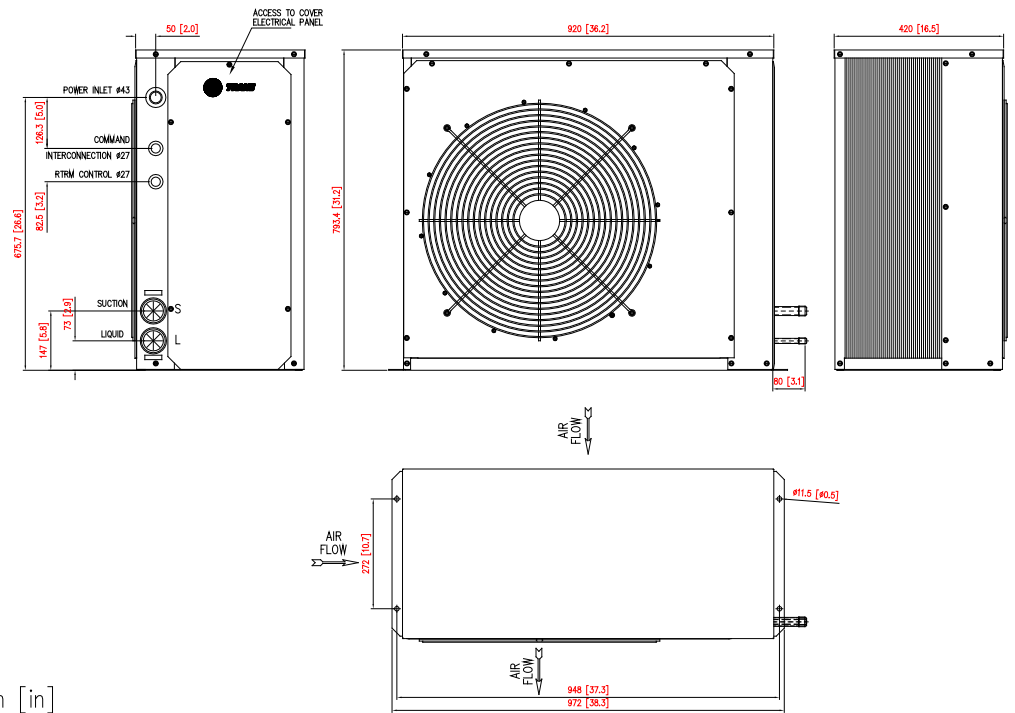

Unit: mm [in]

Fig. 32 - Dimensions - Condensing Units TRAE 075

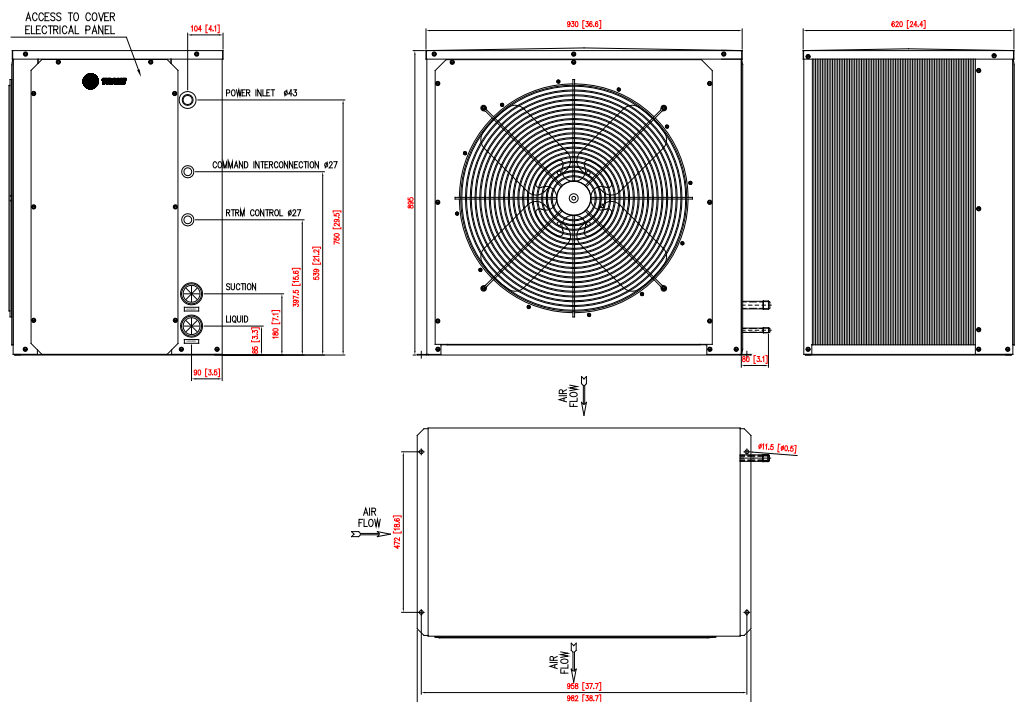

Unit: mm [in]

Dimensional Data

Fig. 33 - Dimensions - Condensing Units TRAE 100 - 1 circuit

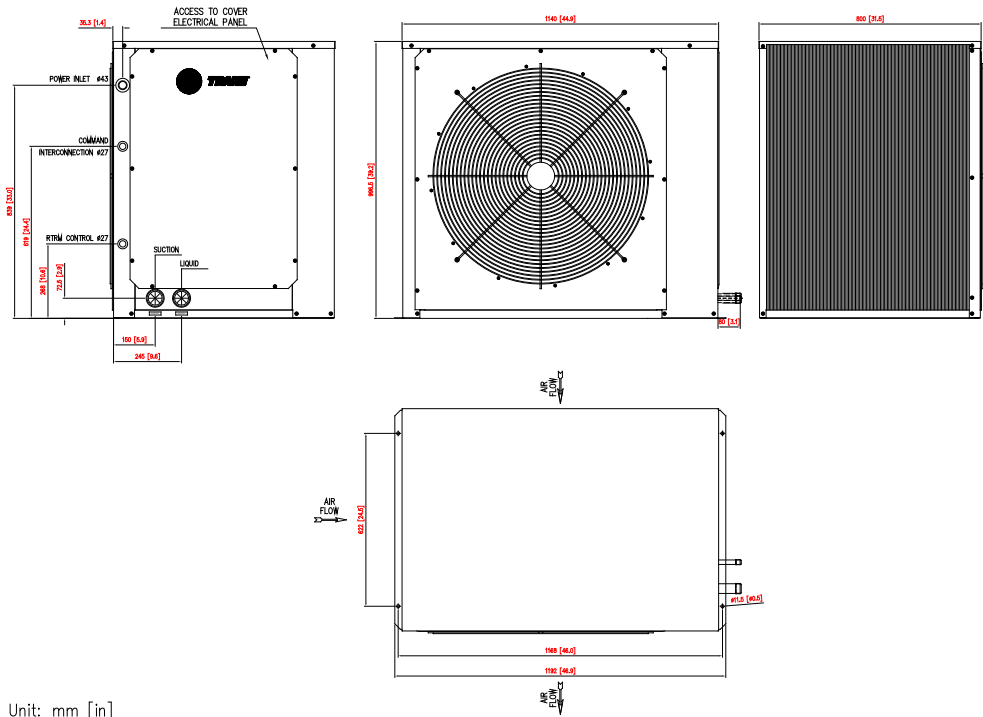

Unit: mm [in]

Fig. 34 - Dimensions - Condensing Units TRAE 100 - 2 circuits

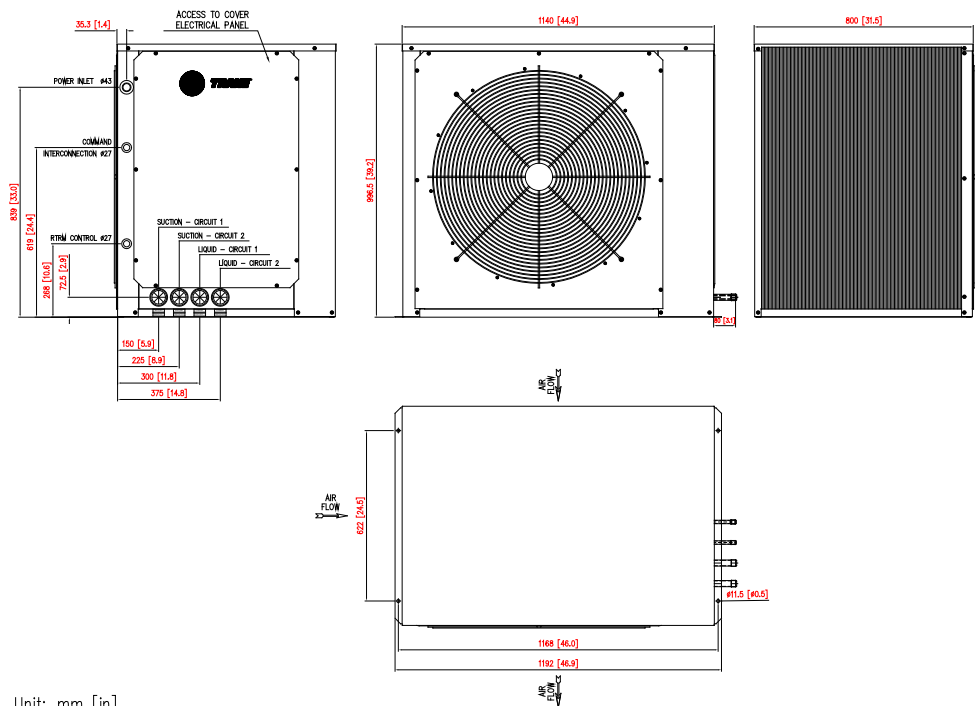

Unit: mm [in]

Dimensional Data

TRAE

Fig. 35 - Dimensions - Condensing Units TRAE 150 - 1 circuit

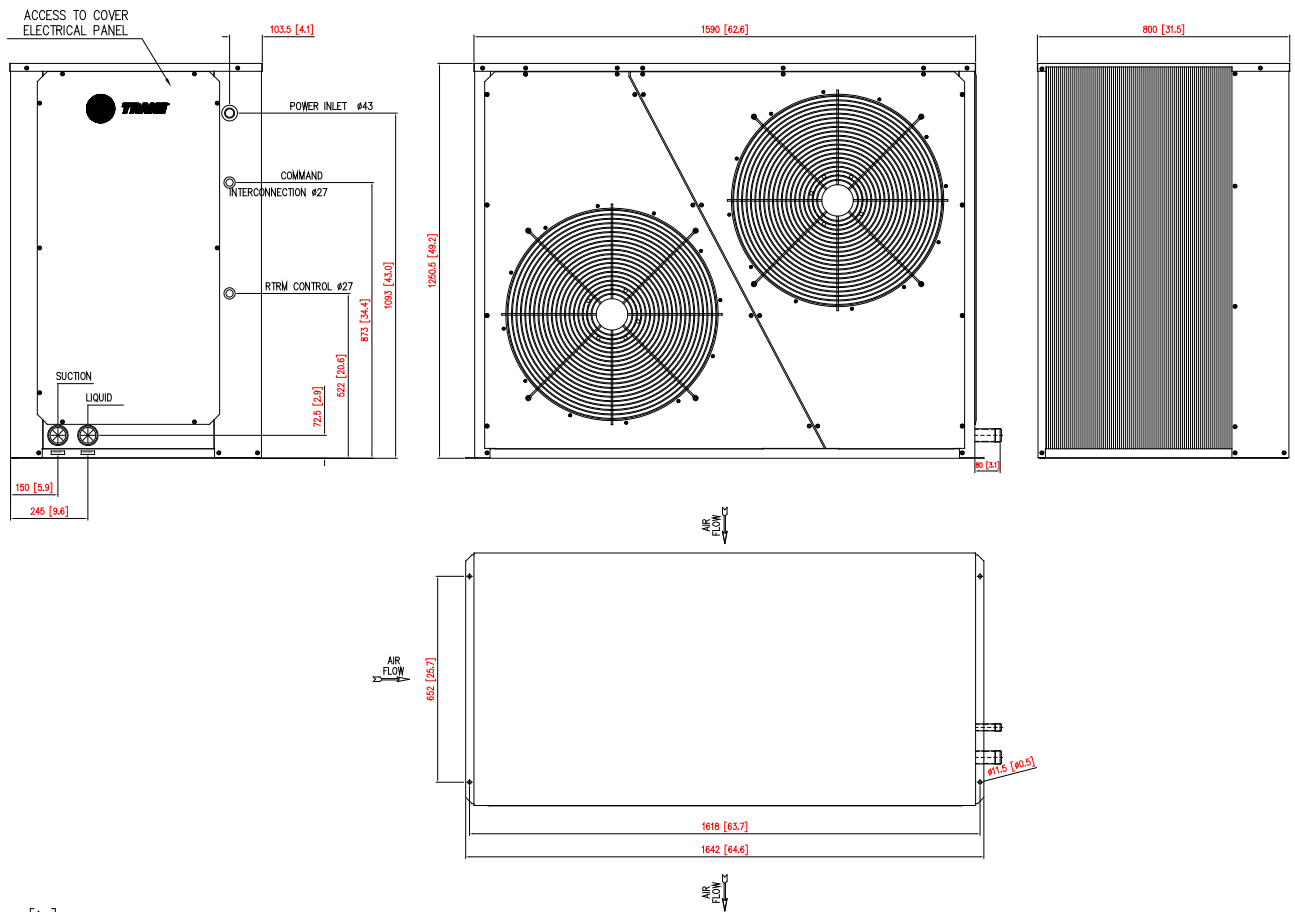

Unit: mm [in]

Dimensional Data

TRAE

Fig. 36 - Dimensions - Condensing Units TRAE 150 - 2 circuits

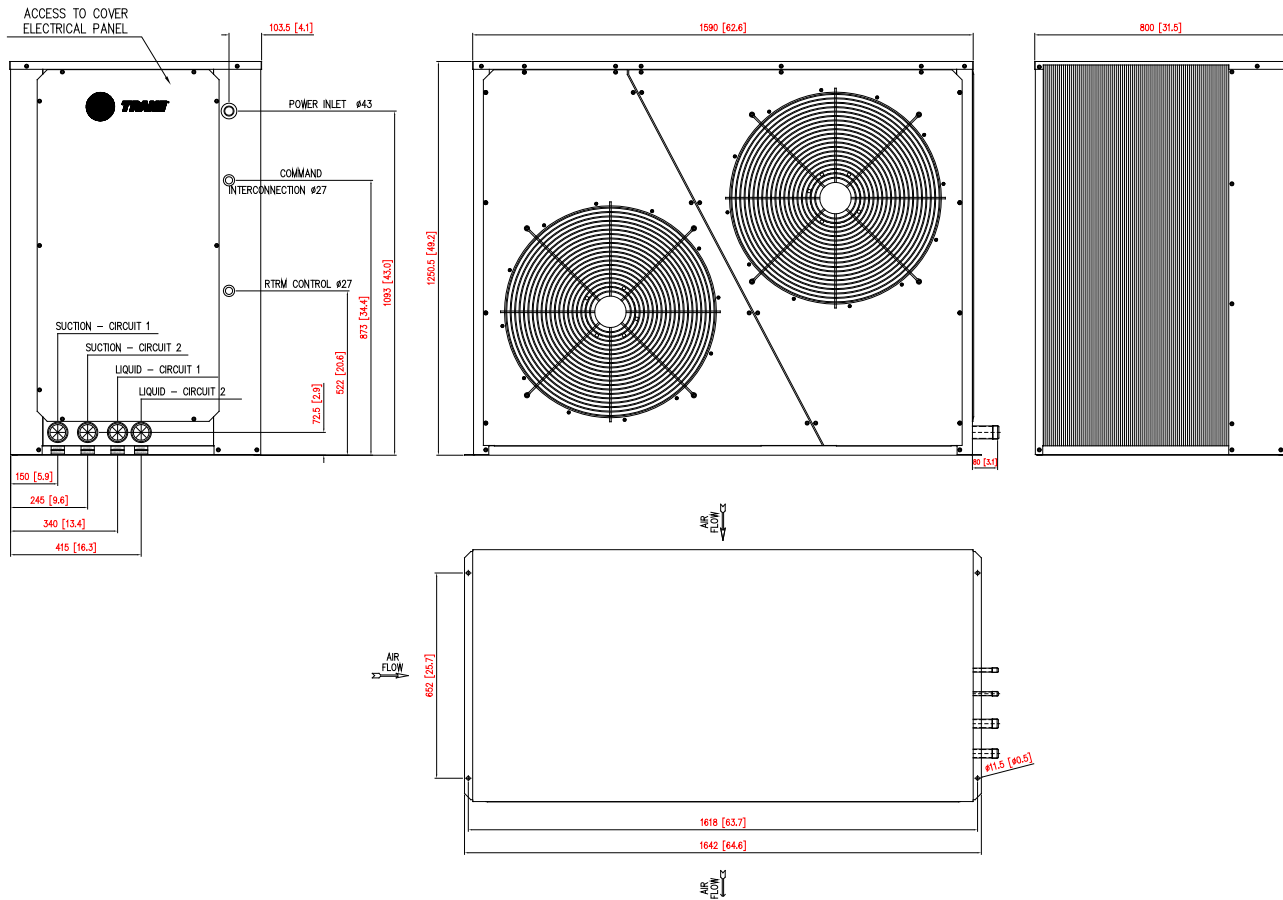

Unit: mm [in]

Dimensional Data

TRAE

Fig. 37 - Dimensions - Condensing Units TRAE 200 - 1 Circuit

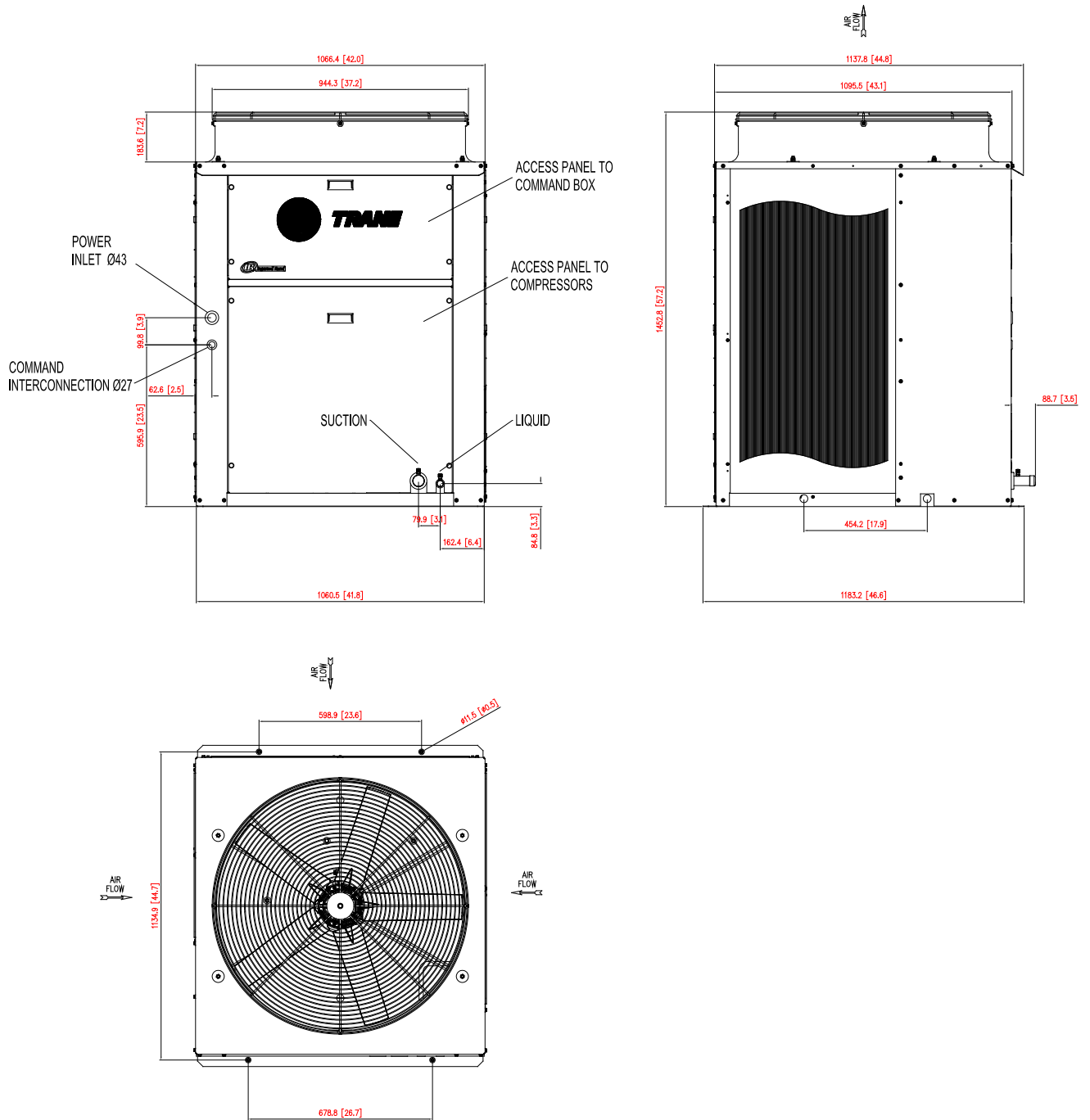

Unit: mm [in]

Dimensional Data

Fig. 38 - Dimensions - Condensing Units TRAE 200 - 2 Circuits

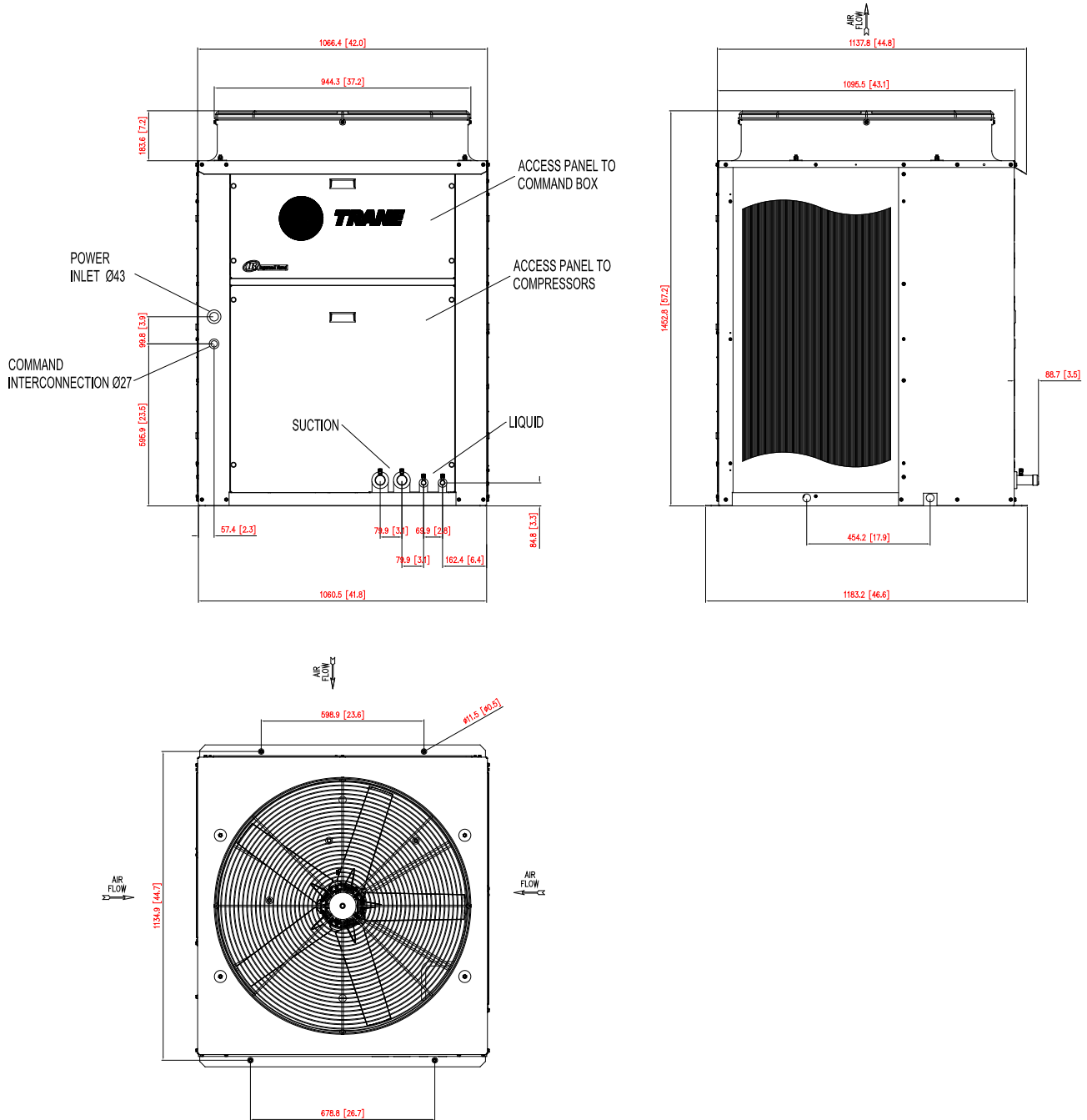

Unit: mm [in]

Dimensional Data

TRAE

Fig. 39 - Dimensions - Condensing Units TRAE 250 - 1 Circuit

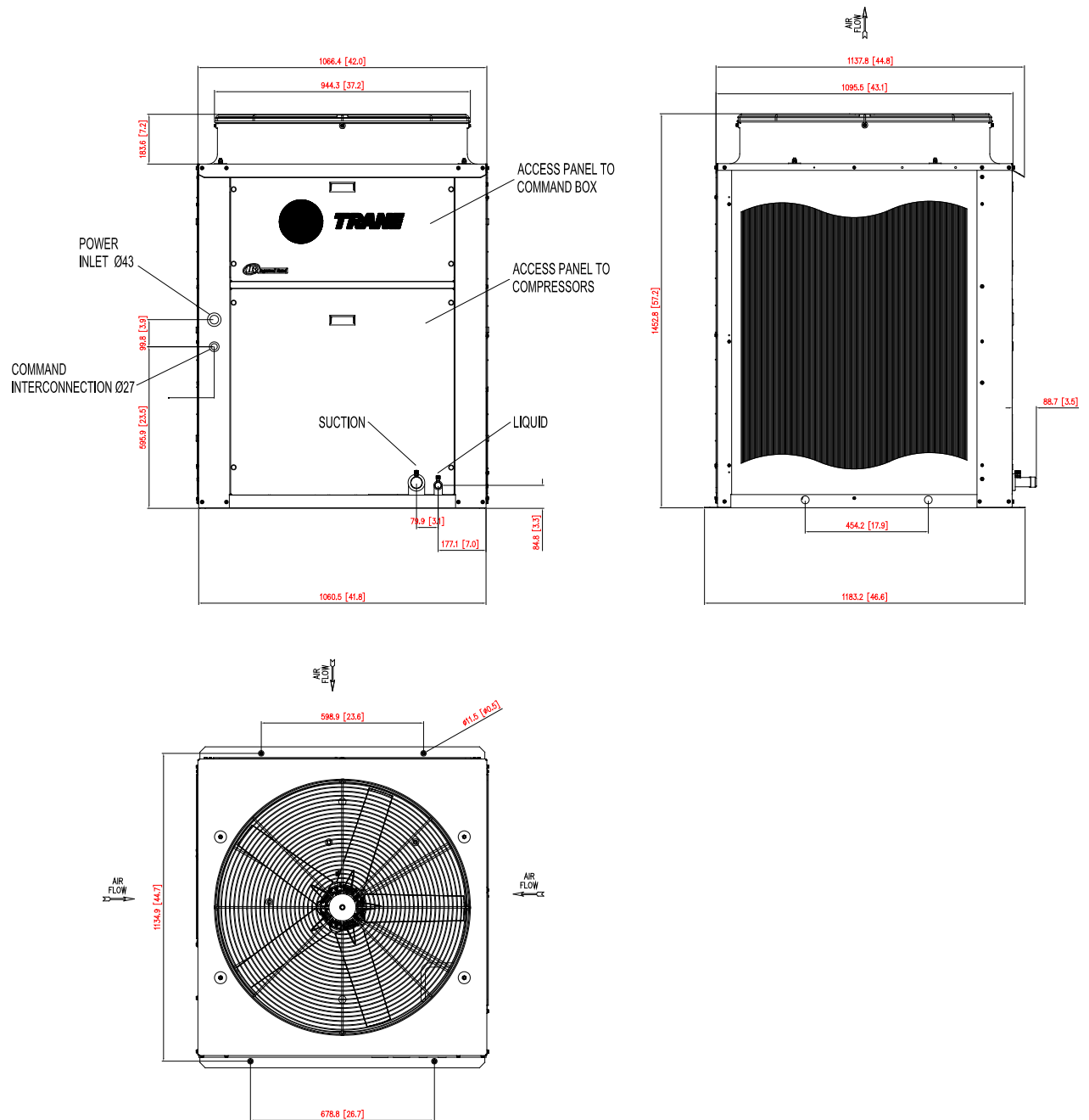

Unit: mm [in]

Dimensional Data

Fig. 40 - Dimensions - Condensing Units TRAE 250 - 2 Circuits

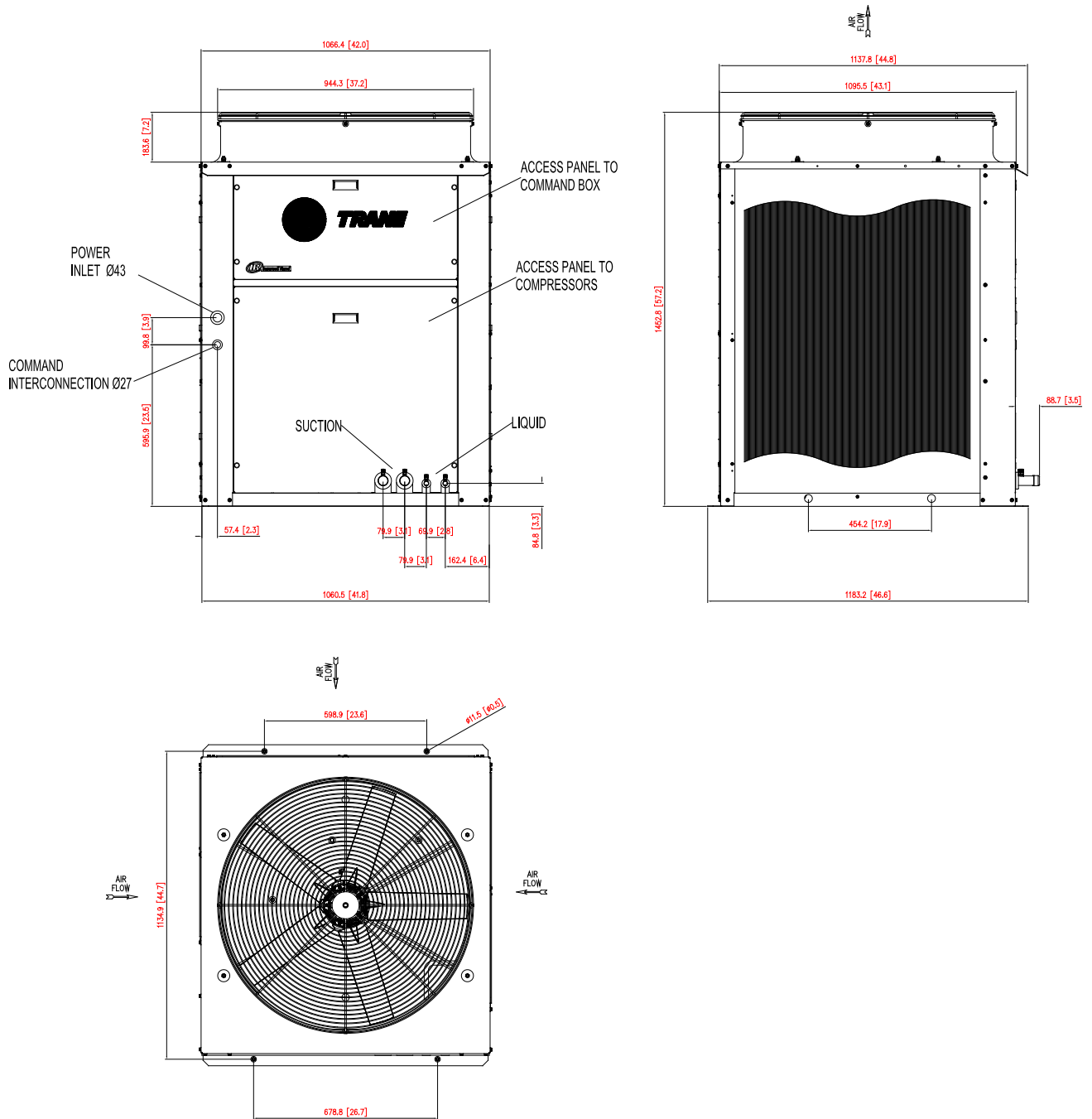

Unit: mm [in]

Dimensional Data

TRCE

Tab. 13 - Dimensions - TRCE

Cota	Modelo			
	050	075	100	150
A	922	1146	1420	1640
B	1373	1474	1525	1829
C	560	560	560	560
D	341	341	290	341
E	374	480	402	432
F	386	386	326	386
G	---	---	230	255
H	778	879	930	1234
K	813	914	965	1269
L	560	560	560	560

Fig. 42 - Dimensions - TRCE

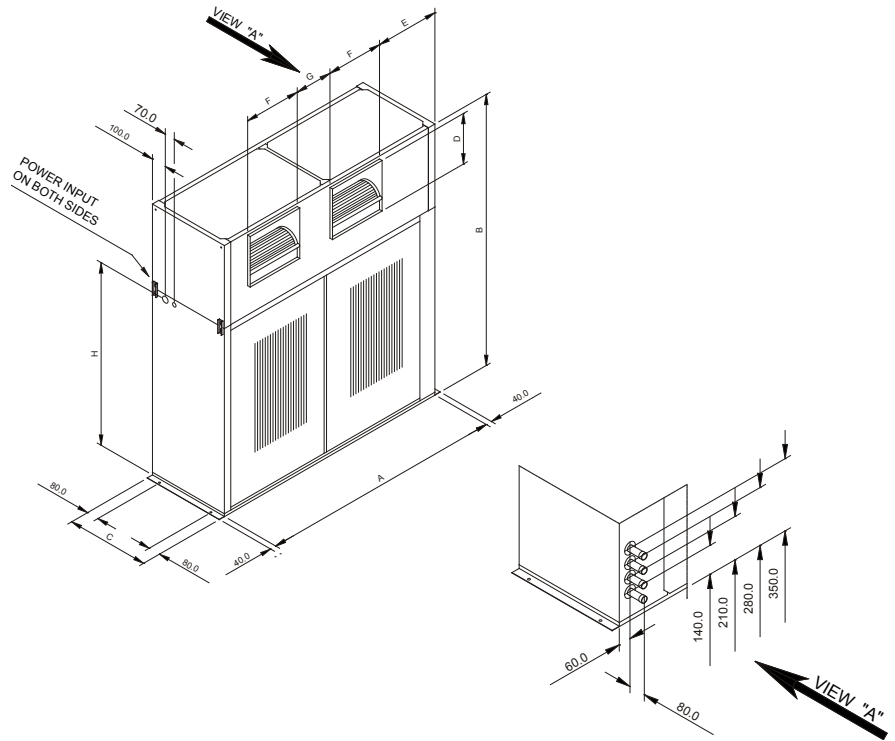
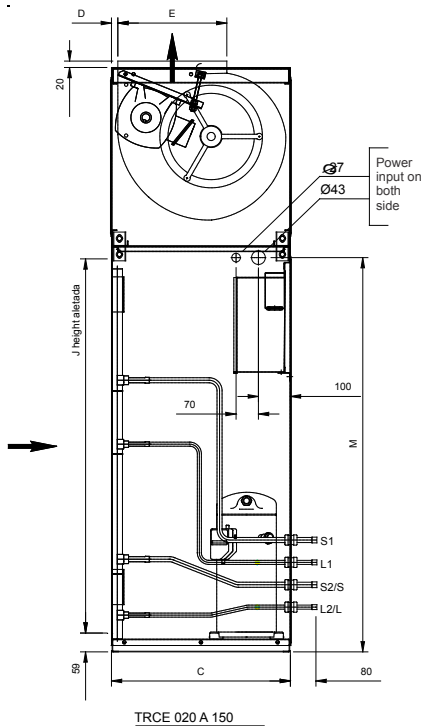

Fig. 41 - Connections - condensing unit TRCE



Tab.14 - Dimensions - TRCE

	Measures (mm)				
	C	D	E	J	M
Models TRCE					
50	560	20	341	711	778
75	560	20	341	813	879
100C/1	560	95	290	864	930
100C/2	560	95	290	864	930
150C/1	560	20	341	1168	1234
150C/2	560	20	341	1168	1234

Tab. 15 - Connection dimensions - TRCE

Connections (pol)	Models TRCE					
	050	075	100C/1	100C/2	150C/1	150C/2
S1	---	---	---	7/8"	---	1 1/8"
L1	---	---	---	1/2"	---	1/2"
S2/S	7/8	1 1/8"	1 3/8"	7/8"	1 5/8"	1 1/8"
L2/L	1/2"	1/2"	5/8"	1/2"	7/8"	1/2"

Dimensional Application Considerations

Data TRAE / TRCE

Fig. 43 - Clearances required for Maintenance and Air Circulation - TRAE

Suggests clearances TRAE 050 to 150 - Horizontal Discharge

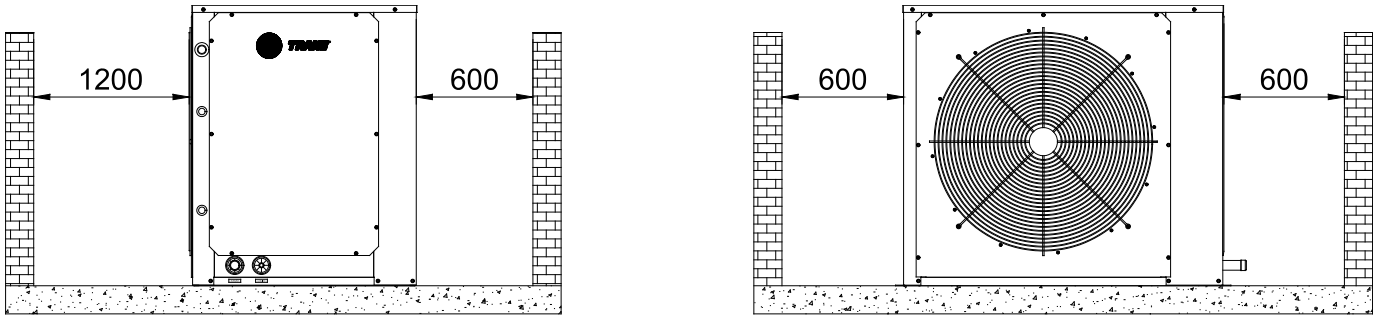

Fig. 44 - Suggested clearances TRAE 200 to 250 - Vertical Discharge

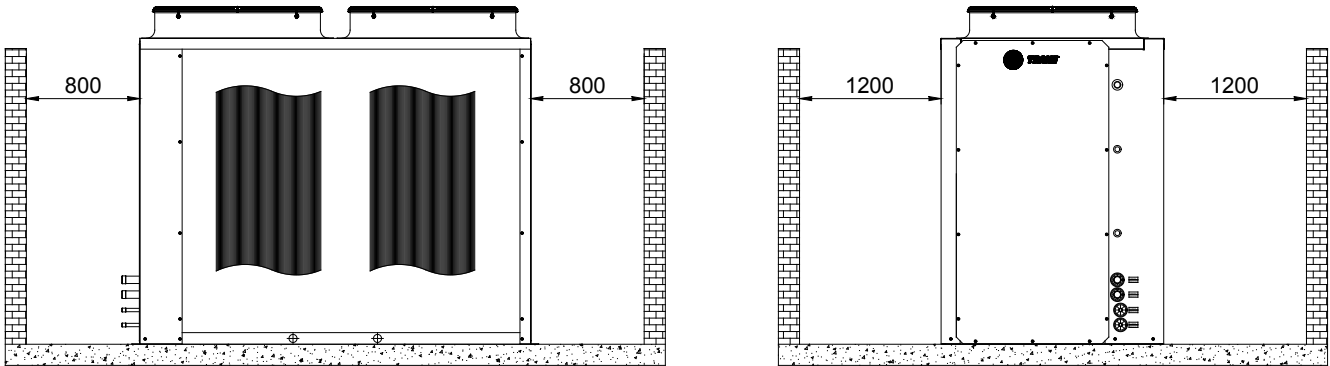
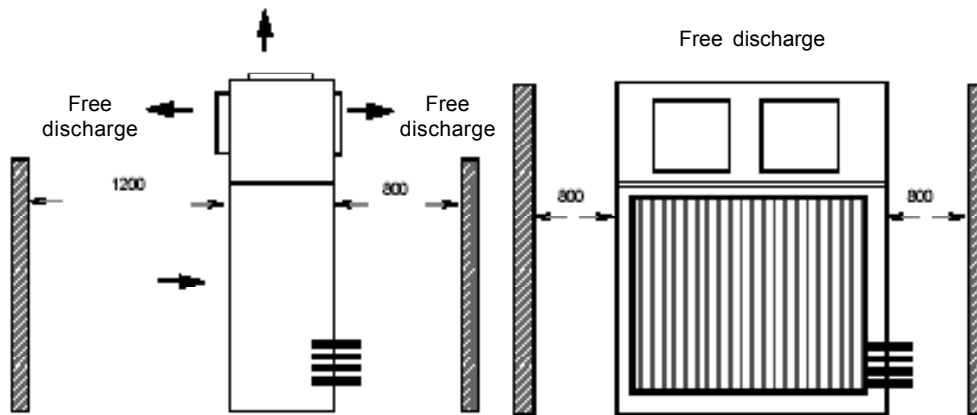

Fig. 45 - Suggested Clearances for Maintenance and Air Circulation - Condensing Unit TRCE 050 to 150.



Unit: mm



Conversion Table

To convert from:	To:	Multiply By:	To convert from:	To:	Multiply By:
Length			Velocity		
Feet (ft)	meters (m)	0,30481	Feet per minute (ft/min)	meters per second (m/s)	0,00508
Inche (in)	millimeters (mm)	25,4	Feet per second (ft/s)	meters per second (m/s)	0,3048
Area			Energy, Power and Capacity		
Square feet (ft ²)	square meters(m ²)	0,93	British Termal Units (BTU)	Kilowatt (KW)	0,000293
Square inche(in ²)	square millimeters(mm ²)	645,2	British Termal Units (BTU)	Kilocalorie (kcal)	0,252
			Tons (refrig. Effect)	Kilowatt (KW)	3,516
			Tons (refrig. Effect)	Kilocalorie per hour (kcal/h)	3024
			Horsepower (HP)	Kilowatt (KW)	0,7457
Volume			Pressure		
Cubic feet (ft ³)	cubic meters(m ³)	0,0283	Feet of water (ft. ² O)	Pascal (Pa)	2990
Cubic Inche (in ³)	cubic millimeters (mm ³)	16387	Inches os water (in. ² O)	Pascal (Pa)	249
Gallons (gal)	litres (L)	3,785	Pounds per square inch (PSI)	Pascal (Pa)	6895
Gallons (gal)	cubic meters (m ³)	0,003785	Pounds per square inch (PSI)	Bar ou kg/cm ²	6,895x10 ⁻²
Flow			Weight		
Cubic feet / min (cfm)	cubic meters /second (m ³ /s)	0,000472	Ounces (oz)	Kilograms (kg)	0,02835
Cubic feet / min (cfm)	cubic meters /hour (m ³ /h)	1,69884	Pounds (lbs)	Kilograms (kg)	0,4536
Gallons / min (GPM)	cubic meters /hour (m ³ /h)	0,2271			
Gallons / min (GPM)	litres / second (L/s)	0,06308			

T emperature		
°C	C ou F	°F
-40,0	-40	-40
-39,4	-39	-38,2
-38,9	-38	-36,4
-38,3	-37	-34,6
-37,8	-36	-32,8
-37,2	-35	-31
-36,7	-34	-29,2
-36,1	-33	-27,4
-35,6	-32	-25,6
-35,0	-31	-23,8
-34,4	-30	-22
-33,9	-29	-20,2
-33,3	-28	-18,4
-32,8	-27	-16,6
-32,2	-26	-14,8
-31,7	-25	-13
-31,1	-24	-11,2
-30,6	-23	-9,4
-30,0	-22	-7,6
-29,4	-21	-5,8
-28,9	-20	-4
-28,3	-19	-2,2
-27,8	-18	-0,4
-27,2	-17	1,4
-26,7	-16	3,2
-26,1	-15	5
-25,6	-14	6,8
-25,0	-13	8,6
-24,4	-12	10,4
-23,9	-11	12,2
-23,3	-10	14
-22,8	-9	15,8
-22,2	-8	17,6
-21,7	-7	19,4
-21,1	-6	21,2
-20,6	-5	23
-20,0	-4	24,8
-19,4	-3	26,6
-18,9	-2	28,4
-18,3	-1	30,2
-17,8	0	32
-17,2	1	33,8
-16,7	2	35,6
-16,1	3	37,4
-15,6	4	39,2

Temperature		
°C	C ou F	°F
-15,0	5	41
-14,4	6	42,8
-13,9	7	44,6
-13,3	8	46,4
-12,8	9	48,2
-12,2	10	50
-11,7	11	51,8
-11,1	12	53,6
-10,6	13	55,4
-10,0	14	57,2
-9,4	15	59
-8,9	16	60,8
-8,3	17	62,6
-7,8	18	64,4
-7,2	19	66,2
-6,7	20	68
-6,1	21	69,8
-5,6	22	71,6
-5,0	23	73,4
-4,4	24	75,2
-3,9	25	77
-3,3	26	78,8
-2,8	27	80,6
-2,2	28	82,4
-1,7	29	84,2
-1,1	30	86
-0,6	31	87,8
0,0	32	89,6
0,6	33	91,4
1,1	34	93,2
1,7	35	95
2,2	36	96,8
2,8	37	98,6
3,3	38	100,4
3,9	39	102,2
4,4	40	104
5,0	41	105,8
5,6	42	107,6
6,1	43	109,4
6,7	44	111,2
7,2	45	113
7,8	46	114,8
8,3	47	116,6
8,9	48	118,4
9,4	49	120,2

Temperature		
°C	C ou F	°F
10,0	50	122
10,6	51	123,8
11,1	52	125,6
11,7	53	127,4
12,2	54	129,2
12,8	55	131
13,3	56	132,8
13,9	57	134,6
14,4	58	136,4
15,0	59	138,2
15,6	60	140
16,1	61	141,8
16,7	62	143,6
17,2	63	145,4
17,8	64	147,2
18,3	65	149
18,9	66	150,8
19,4	67	152,6
20,0	68	154,4
20,6	69	156,2
21,1	70	158
21,7	71	159,8
22,2	72	161,6
22,8	73	163,4
23,3	74	165,2
23,9	75	167
24,4	76	168,8
25,0	77	170,6
25,6	78	172,4
26,1	79	174,2
26,7	80	176
27,2	81	177,8
27,8	82	179,6
28,3	83	181,4
28,9	84	183,2
29,4	85	185
30,0	86	186,8
30,6	87	188,6
31,1	88	190,4
31,7	89	192,2
32,2	90	194
32,8	91	195,8
33,3	92	197,6
33,9	93	199,4
34,4	94	201,2

Temperature		
°C	C ou F	°F
35,0	95	203
35,6	96	204,8
36,1	97	206,6
36,7	98	208,4
37,2	99	210,2
37,8	100	212
38,3	101	213,8
38,9	102	215,6
39,4	103	217,4
40,0	104	219,2
40,6	105	221
41,1	106	222,8
41,7	107	224,6
42,2	108	226,4
42,8	109	228,2
43,3	110	230
43,9	111	231,8
44,4	112	233,6
45,0	113	235,4
45,6	114	237,2
46,1	115	239
46,7	116	240,8
47,2	117	242,6
47,8	118	244,4
48,3	119	246,2
48,9	120	248
49,4	121	249,8
50,0	122	251,6
50,6	123	253,4
51,1	124	255,2
51,7	125	257
52,2	126	258,8
52,8	127	260,6
53,3	128	262,4
53,9	129	264,2
54,4	130	266
55,0	131	267,8
55,6	132	269,6
56,1	133	271,4
56,7	134	273,2
57,2	135	275
57,8	136	276,8
58,3	137	278,6
58,9	138	280,4
59,4	139	282,2

Temperature		
°C	C ou F	°F
60,0	140	284
60,6	141	285,8
61,1	142	287,6
61,7	143	289,4
62,2	144	291,2
62,8	145	293
63,3	146	294,8
63,9	147	296,6
64,4	148	298,4
65,0	149	300,2
65,6	150	302
66,1	151	303,8
66,7	152	305,6
67,2	153	307,4
67,8	154	309,2
68,3	155	311
68,9	156	312,8
69,4	157	314,6
70,0	158	316,4
70,6	159	318,2
71,1	160	320
71,7	161	321,8
72,2	162	323,6
72,8	163	325,4
73,3	164	327,2
73,9	165	329
74,4	166	330,8
75,0	167	332,6
75,6	168	334,4
76,1	169	336,2
76,7	170	338
77,2	171	339,8
77,8	172	341,6
78,3	173	343,4
78,9	174	345,2
79,4	175	347
80,0	176	348,8
80,6	177	350,6
81,1	178	352,4
81,7	179	354,2
82,2	180	356
82,8	181	357,8
83,3	182	359,6
83,9	183	361,4
84,4	184	363,2



Trane optimizes the performance of homes and buildings around the world. A business of Ingersoll Rand, the leader in creating and sustaining safe, comfortable and energy efficient environments, Trane offers a broad portfolio of advanced controls and HVAC systems, comprehensive building services, and parts. For more information, visit www.trane.com.br

Trane has a policy of continuous product and product data improvement and reserves the right to change design and specifications without notice.

© 2017 Trane
All rights reserved
SSC-SVN001H EN December 2017
Supersedes SSC-SVN001G EN February 2017

We are committed to environmentally friendly
printing practices that reduce waste.

