



TRANE[®]

Installation

Location of Parts for KIT09157, KIT09158, and KIT09159

Models: RTAA



Installation

Table 1. KIT09157

Component Location Number	Part Name	Mnemonic	Qty per Kit
1	Kit; 70 Ton Slide Valve	KIT02583	1
2	Ring; Discharge	RNG01406	1
3	Valve; Solenoid	VAL02843	2
4	Gasket; Solenoid Valve	GKT01612	2
5	Gasket; Terminal Plate	GKT03811	1
6	Plate; Terminal	PLT03341	1
7	Terminal; Motor	TER00010	6
8	Kit; Terminal Rebuild (Consists of: 2 Insulators, 1 O-Ring, 1 Nut & 1 Washer)	KIT05241	6
*	Element; Oil Filter (Includes RNG01248)	ELM01042	1
*	Control; Oil Pressure	CNT02304	1
*	Control; Low Pressure	CNT01317	1
*	Ring; Suction Line, 3.234 (130/140 Ton Unit)	RNG00636	2
*	Ring; Suction Line, 3.859 (155-400 Ton Unit)	RNG01410	2

* Not Illustrated

Installation

Table 2. KIT09158

Component Location Number	Part Name	Mnemonic	Qty per Kit
1	Kit; 85 Ton Slide Valve	KIT02584	1
2	Ring; Discharge	RNG01410	1
3	Valve; Solenoid	VAL02843	2
4	Gasket; Solenoid Valve	GKT01612	2
5	Gasket; Terminal Plate	GKT03811	1
6	Plate; Terminal	PLT03341	1
7	Terminal; Motor	TER00010	6
8	Kit; Terminal Rebuild (Consists of: 2 Insulators, 1 O-Ring, 1 Nut & 1 Washer)	KIT05241	6
*	Element; Oil Filter (Includes RNG01248)	ELM01042	1
*	Control; Oil Pressure	CNT02304	1
*	Control; Low Pressure	CNT01317	1
*	Ring; Suction Line, 3.234 (130/140 Ton Unit)	RNG00636	2
*	Ring; Suction Line, 3.859 (155-400 Ton Unit)	RNG01410	2

* Not Illustrated



Installation

Table 3. KIT09159

Component Location Number	Part Name	Mnemonic	Qty per Kit
1	Kit; 100 Ton Slide Valve	KIT02585	1
2	Ring; Discharge	RNG01410	1
3	Valve; Solenoid	VAL02843	2
4	Gasket; Solenoid Valve	GKT01612	2
5	Gasket; Terminal Plate	GKT03811	1
6	Plate; Terminal	PLT03341	1
7	Terminal; Motor	TER00010	6
8	Kit; Terminal Rebuild (Consists of: 2 Insulators, 1 O-Ring, 1 Nut & 1 Washer)	KIT05241	6
*	Element; Oil Filter (Includes RNG01248)	ELM01042	1
*	Control; Oil Pressure	CNT02304	1
*	Control; Low Pressure	CNT01317	1
*	Ring; Suction Line, 3.234 (130/140 Ton Unit)	RNG00636	2
*	Ring; Suction Line, 3.859 (155-400 Ton Unit)	RNG01410	2

* Not Illustrated

Installation

Component Locations

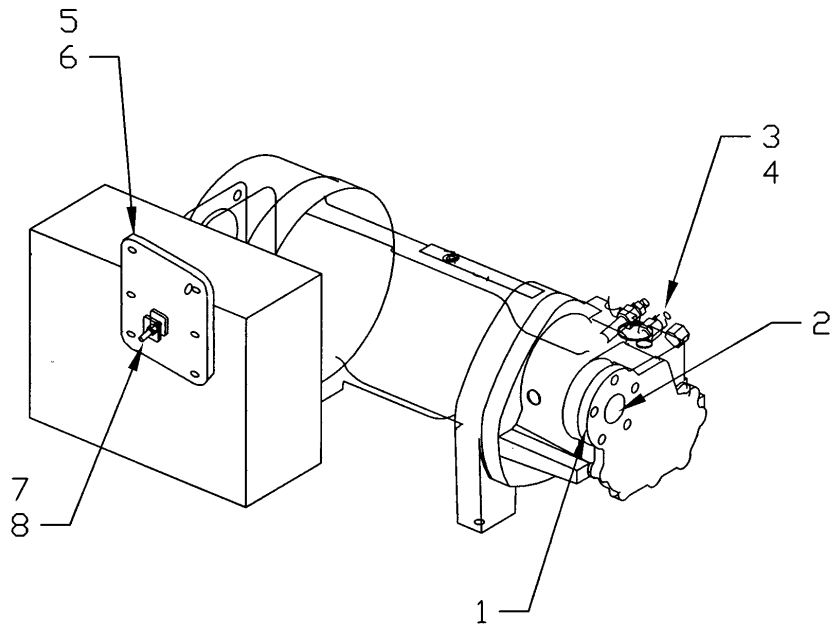



Trane
A business of American Standard Companies
www.trane.com

For more information, contact your local district office or e-mail us at comfort@trane.com

Literature Order Number	PART-SVN57A-EN
File Number	SV-General-PART-SVN57A-EN-0903
Supersedes	New
Stocking Location	Electronic Only

Trane has a policy of continuous product data and product improvement and reserves the right to change design and specifications without notice. Only qualified technicians should perform the installation and servicing of equipment referred to in this bulletin.