

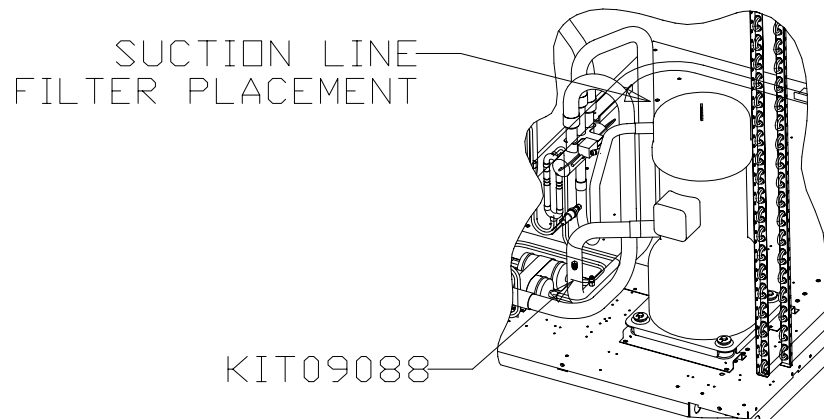

TRANE[®]

Installation

Compressor Replacement Kit for CSHB to CSHC Conversion, KIT09088



**Figure 1. Compressor replacement illustration for
TWA100AD**D, TWA120A3**D, TWA120A4**D, and
TWA120AW**D**

Models: CSHC, CSHB, TWA100AD**D, TWA120A3**D,
TWA120A4**D, and TWA120AW**D

Installation

Compressor Replacement Kit for CSHB to CSHC Conversion

KIT09088 includes

- 1 - Suction tube assembly, part number D670898G01
- 1 - Discharge tube assembly, part number D670901G01

Instructions

1. Unbrazed and remove compressor by following compressor service guidelines.
2. Unbrazed and remove current suction and discharge tube from compressor.
3. Replace compressor and braze new tube(s) into new compressor.
 - It is important that a dry nitrogen purge is used while brazing.
 - Make sure not to overheat service valve or reversing valve. Use a wet rag to cool parts while brazing.
 - Add suction line filter when necessary.



Trane
A business of American Standard Companies
www.trane.com

For more information, contact your local district office or e-mail us at comfort@trane.com

Literature Order Number	PART-SVN43A-EN
File Number	SV-Compressors-PART-SVN43A-EN-0603
Supersedes	New
Stocking Location	Electronic Only

Trane has a policy of continuous product data and product improvement and reserves the right to change design and specifications without notice. Only qualified technicians should perform the installation and servicing of equipment referred to in this bulletin.