



**TRANE<sup>®</sup>**

## Installation

---

### **Compressor Replacement Kit for CSHB to CSHC Conversion, KIT08437 and KIT08438**

**Models:** CSHC, CSHB, and WC 180B

# Compressor replacement illustration for WC 180B

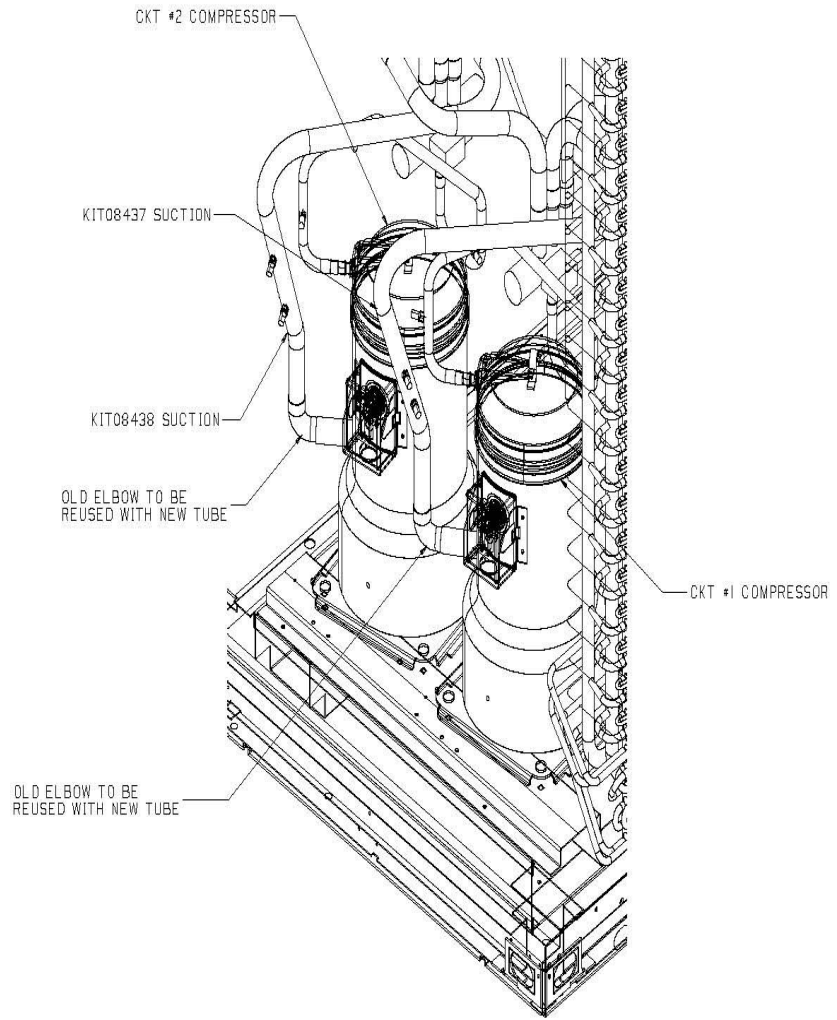

# Installation

---

## Compressor Replacement Kit for CSHB to CSHC Conversion

### KIT08437, Includes

1 - Ckt #1 Suction tube assembly, part number 4385-5049

### KIT08438, Includes

1 - Ckt #2 Suction tube assembly, part number 4385-5050

### Instructions

1. Remove compressor by following compressor service guidelines.
2. Remove current suction and discharge tube from the compressor.
3. Replace compressor and braze new suction tube(s) and old discharge tube into new compressor. Reconnect LPC (low pressure control). Note: old suction line elbows are to be reused with replacement tubing.
  - It is important that a dry nitrogen purge is used while brazing.
  - Make sure not to overheat service valve or reversing valve. Use a wet rag to cool parts while brazing.



**Trane**  
A business of American Standard Companies  
[www.trane.com](http://www.trane.com)

For more information, contact your local district office or e-mail us at [comfort@trane.com](mailto:comfort@trane.com)

---

Literature Order Number	PART-SVN40A-EN
File Number	SV-Compressors-PART-SVN40A-EN-0503
Supersedes	New
Stocking Location	Electronic Only

---

*Trane has a policy of continuous product data and product improvement and reserves the right to change design and specifications without notice. Only qualified technicians should perform the installation and servicing of equipment referred to in this bulletin.*