

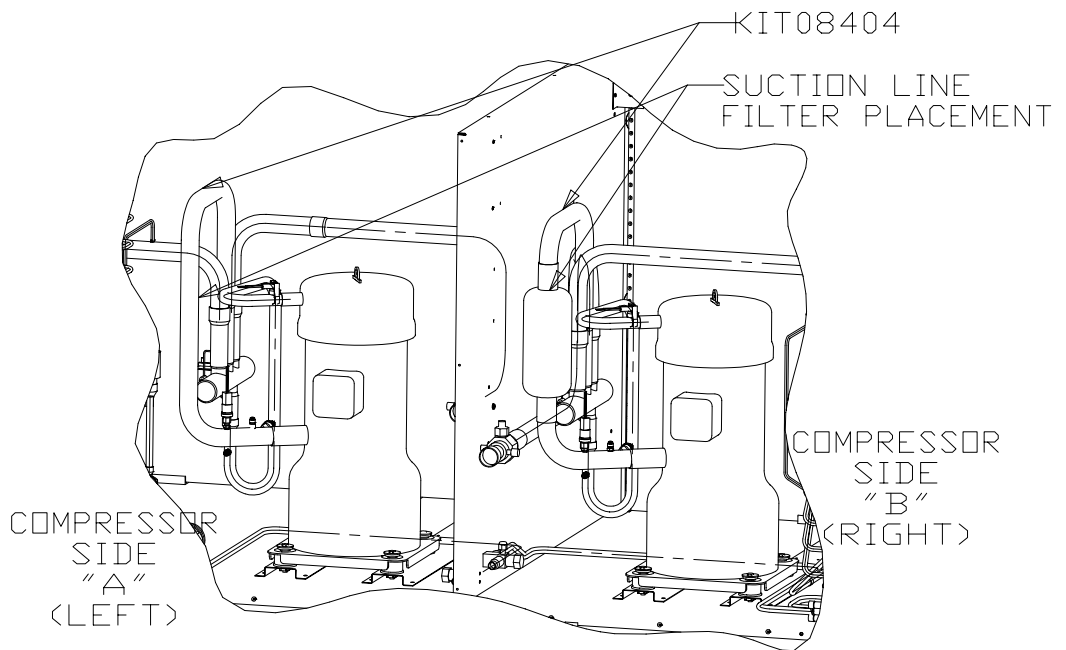

TRANE®

Installation

Compressor Replacement Kit for CSHB to CSHC Conversion, KIT08404



Compressor replacement illustration for TWA240B

Models: CSHC, CSHB, TWA240B

Installation

Compressor Replacement Kit for CSHB to CSHC Conversion

KIT08404 includes

For sides "A" or "B"

1 - Suction tube assembly, part number D670684G01

Instructions

1. Remove compressor by following compressor service guidelines.
2. Remove current suction tube from compressor.
3. Replace compressor and braze new tube(s) into new compressor.
 - It is important that a dry nitrogen purge is used while brazing.
 - Make sure not to overheat service valve or reversing valve. Use a wet rag to cool parts while brazing.
 - Add suction line filter when necessary.



Trane
A business of American Standard Companies
www.trane.com

For more information, contact your local district office or e-mail us at comfort@trane.com

| | |
|-------------------------|------------------------------------|
| Literature Order Number | PART-SVN36A-EN |
| File Number | SV-Compressors-PART-SVN36A-EN-0503 |
| Supersedes | New |
| Stocking Location | Electronic Only |

Trane has a policy of continuous product data and product improvement and reserves the right to change design and specifications without notice. Only qualified technicians should perform the installation and servicing of equipment referred to in this bulletin.