



Installation Instructions

Ceramic Bearing Replacement

CVHE and CVHF CenTraVac™ Chillers

SAFETY WARNING

Only qualified personnel should install and service the equipment. The installation, starting up, and servicing of heating, ventilating, and air-conditioning equipment can be hazardous and requires specific knowledge and training. Improperly installed, adjusted or altered equipment by an unqualified person could result in death or serious injury. When working on the equipment, observe all precautions in the literature and on the tags, stickers, and labels that are attached to the equipment.



Introduction

Read this manual thoroughly before operating or servicing this unit.

Warnings, Cautions, and Notices

Safety advisories appear throughout this manual as required. Your personal safety and the proper operation of this machine depend upon the strict observance of these precautions.

The three types of advisories are defined as follows:

⚠ WARNING Indicates a potentially hazardous situation which, if not avoided, could result in death or serious injury.

⚠ CAUTION Indicates a potentially hazardous situation which, if not avoided, could result in minor or moderate injury. It could also be used to alert against unsafe practices.

NOTICE Indicates a situation that could result in equipment or property-damage only accidents.

Important Environmental Concerns

Scientific research has shown that certain man-made chemicals can affect the earth's naturally occurring stratospheric ozone layer when released to the atmosphere. In particular, several of the identified chemicals that may affect the ozone layer are refrigerants that contain Chlorine, Fluorine and Carbon (CFCs) and those containing Hydrogen, Chlorine, Fluorine and Carbon (HCFCs). Not all refrigerants containing these compounds have the same potential impact to the environment. Trane advocates the responsible handling of all refrigerants-including industry replacements for CFCs and HCFCs such as saturated or unsaturated HFCs and HCFCs.

Important Responsible Refrigerant Practices

Trane believes that responsible refrigerant practices are important to the environment, our customers, and the air conditioning industry. All technicians who handle refrigerants must be certified according to local rules. For the USA, the Federal Clean Air Act (Section 608) sets forth the requirements for handling, reclaiming, recovering and recycling of certain refrigerants and the equipment that is used in these service procedures. In addition, some states or municipalities may have additional requirements that must also be adhered to for responsible management of refrigerants. Know the applicable laws and follow them.

⚠ WARNING

Proper Field Wiring and Grounding Required!

Failure to follow code could result in death or serious injury. All field wiring **MUST** be performed by qualified personnel. Improperly installed and grounded field wiring poses **FIRE** and **ELECTROCUTION** hazards. To avoid these hazards, you **MUST** follow requirements for field wiring installation and grounding as described in **NEC** and your local/state electrical codes.

⚠ WARNING

Personal Protective Equipment (PPE) Required!

Failure to wear proper PPE for the job being undertaken could result in death or serious injury. Technicians, in order to protect themselves from potential electrical, mechanical, and chemical hazards, **MUST** follow precautions in this manual and on the tags, stickers, and labels, as well as the instructions below:

- Before installing/servicing this unit, technicians **MUST** put on all PPE required for the work being undertaken (Examples; cut resistant gloves/sleeves, butyl gloves, safety glasses, hard hat/bump cap, fall protection, electrical PPE and arc flash clothing). **ALWAYS** refer to appropriate Safety Data Sheets (SDS) and OSHA guidelines for proper PPE.
- When working with or around hazardous chemicals, **ALWAYS** refer to the appropriate SDS and OSHA/GHS (Global Harmonized System of Classification and Labeling of Chemicals) guidelines for information on allowable personal exposure levels, proper respiratory protection and handling instructions.
- If there is a risk of energized electrical contact, arc, or flash, technicians **MUST** put on all PPE in accordance with OSHA, NFPA 70E, or other country-specific requirements for arc flash protection, **PRIOR** to servicing the unit. **NEVER PERFORM ANY SWITCHING, DISCONNECTING, OR VOLTAGE TESTING WITHOUT PROPER ELECTRICAL PPE AND ARC FLASH CLOTHING. ENSURE ELECTRICAL METERS AND EQUIPMENT ARE PROPERLY RATED FOR INTENDED VOLTAGE.**

Copyright

This document and the information in it are the property of Trane, and may not be used or reproduced in whole or in part without written permission. Trane reserves the right to revise this publication at any time, and to make changes to its content without obligation to notify any person of such revision or change.

Trademarks

All trademarks referenced in this document are the trademarks of their respective owners.

Revision History

PART-SVN124C-EN (04 Aug 2014)

- Table 4 updated



Models Affected

⚠ WARNING

Hazardous Voltage w/Capacitors!

Failure to disconnect power and discharge capacitors before servicing could result in death or serious injury. Disconnect all electric power, including remote disconnects and discharge all motor start/run capacitors before servicing. Follow proper lockout/tagout procedures to ensure the power cannot be inadvertently energized. For variable frequency drives or other energy storing components provided by Trane or others, refer to the appropriate manufacturer's literature for allowable waiting periods for discharge of capacitors. Verify with an appropriate voltmeter that all capacitors have discharged.

For additional information regarding the safe discharge of capacitors, see PROD-SVB06A-EN

NOTICE

Use Copper Conductors Only!

Failure to use copper conductors could result in equipment damage as unit terminals are not designed to accept other types of conductors.

CVHE and CVHF CenTraVac™ chillers built after June 2005 with AFDE or AFDG Adaptive Frequency Drives™ installed may be affected.

Reason for Replacement

CenTraVac™ chiller production is discontinuing the use of ceramic bearings in favor of using magnetic cores for spark discharge protection. The cores allow the use of steel bearings. Trane Parts is following this direction with a conversion kit. This is a one-time conversion to add the cores to the AFD.

For the conversion:

- Chillers with AFDE unit-mounted drives require the purchase of steel bearings, a choke kit, and ERIFLEX® FLEXIBAR® (flexible insulated busbar).
- Chillers with AFDG remote-mounted drives require the purchase of steel bearings and a core kit.

Note: FLEXIBAR is not required for AFDG drives because field wiring is used for the remote drives.

Refer to Table 1, p. 4 through Table 4, p. 4 for parts that need to be purchased based on the chiller RLA.

Table 1. Replacement bearings

Original Ceramic Bearing	Replacement Steel Bearing
BRG01641	BRG01639
BRG01642	BRG01640
BRG01655	BRG01542

Table 2. Core kit for AFDE unit-mounted drives

SRRL	Core Kit Part Number
405-608 (Frame 3)	KIT15645
900-1210 (Frame 4)	KIT15646

Table 3. Core kit for AFDG remote-mounted drives

SRRL		Core Kit Part Number
460/480 V	575/600 V	
443 or less (D-Frame)	400 or less (D-Frame)	KIT15647
444-730 (E-Frame)	401-630 (E-Frame)	KIT15648
731-1530 (F-Frame)	631-1415 (F-Frame)	KIT15649

Table 4. FLEXIBAR for AFDE unit-mounted drives

PRLA	SRRL	Starter Size	FLEXIBAR	
			Part Number	Number Required
0-491.2	405-608	Frame 3	BAR00242	3
491.3-643.2	405-608	Frame 3	BAR00197	3
491.3-643.2	900-1210	Frame 4	BAR00197	3
643.3-844.9	900-1210	Frame 4	BAR00197	6
845.0-1210.0	900-1210	Frame 4	BAR00239	6

Notes:

1. PRLA and SRRL can be found on the CenTraVac nameplate.
2. The last column shows the number of FLEXIBAR that will need to be purchased to complete the conversion.

Core Kit Contents

KIT15645

X05010209010	Horizontal Mount Shelf Bracket, Rockwell Automation Frame 3	Qty=1
X13640734010	Magnetic M-116 Cores	Qty=5
X19210282010	Cable Ties 27 in.	Qty=3
X20600036020	Trim-Lok Flexible Edging	Qty=2 @ 7 in. each
Mounting Hardware	3 Bolts, 3 Nuts	

KIT15646

X05010210010	Horizontal Mount Shelf Bracket, Rockwell Automation Frame 4	Qty=1
X13640735010	Magnetic M-117 Cores	Qty=8
X19210282010	Cable Ties 27 in.	Qty=2
X19210282020	Cable Ties 51 in.	Qty=1
X20600036020	Trim-Lok Flexible Edging	Qty=2 @ 11.9 in. each
Mounting Hardware	4 Bolts, 4 Nuts	

KIT15647

Horizontal Mount Shelf Bracket, Danfoss D-Frame	Qty=1
X13640734010	Magnetic M-116 Cores Qty=5
X19210282010	Cable Ties 27 in. Qty=3
X20600036020	Trim-Lok Flexible Edging Qty=2 @ 7 in. each
Mounting Hardware	4 Screws

KIT15648

Horizontal Mount Shelf Bracket, Danfoss E-Frame	Qty=1
X13640734010	Magnetic M-116 Cores Qty=5
X19210282010	Cable Ties 27 in. Qty=3
X20600036020	Trim-Lok Flexible Edging Qty=2 @ 7 in. each
Mounting Hardware	4 Screws

KIT16549

Vertical Mount Shelf Brackets, Danfoss F-Frame	Qty=2
X13640735010	Magnetic M-117 Cores Qty=8
X19210282020	Cable Ties 51 in. Qty=1
Mounting Hardware	6 Screws, 6 Washers

Installation of Core Kits

AFDE Unit-Mounted Drive

⚠ WARNING

Hazardous Voltage w/Capacitors!

Failure to disconnect power and discharge capacitors before servicing could result in death or serious injury. Disconnect all electric power, including remote disconnects and discharge all motor start/run capacitors before servicing. Follow proper lockout/tagout procedures to ensure the power cannot be inadvertently energized. For variable frequency drives or other energy storing components provided by Trane or others, refer to the appropriate manufacturer's literature for allowable waiting periods for discharge of capacitors. Verify with an appropriate voltmeter that all capacitors have discharged.

For additional information regarding the safe discharge of capacitors, see PROD-SVB06A-EN

1. Turn off the main power disconnect to the chiller and then follow the correct lockout/tagout safety procedures to ensure that main power to the machine cannot be inadvertently restored.
 - a. For additional safety, also open all starter and control panel disconnect switches and secure them in the open position.
 - b. Follow proper safety procedures to assure that the capacitors in the drive have been discharged and then verify that no power exists in the drive cabinet.
2. Identify and clearly label the compressor motor terminals and the drive output terminals. The existing

ERIFLEX® FLEXIBAR® (flexible insulated busbar) can now be disconnected and discarded. Do not remove the motor terminal clamps because they will be reused.

3. Caution must be taken during this step to ensure that no metal shavings get into the electronic parts of the drive.
 - a. It is recommended to use coverings and possibly magnets or vacuum to catch any shavings during the drilling process.
 - b. Using the bracket as a template mark the mounting hole locations. Refer to [Figure 1, p. 6](#) and [Figure 2, p. 6](#) for the recommended mounting locations for your particular application.
 - c. Drill the mounting holes with a 7/16 drill bit using caution to not get shavings into the electronics.
 - d. Bolt the bracket to the drive cabinet using the provided hardware.
 - e. Set the magnetic cores onto the shelf and secure them into place using the supplied cable ties.

Note: You may want to wait to secure the cores to the bracket to make it easier to install the FLEXIBAR.

4. Route the FLEXIBAR through the center of the cores and secure to the proper terminals at the motor and drive output. In some cases the original FLEXIBAR can be reused but in most cases new FLEXIBAR will need to be bent and cut to fit.

NOTICE

Equipment Damage!

Failure to follow the instructions below could result in equipment damage. When tightening FLEXIBAR connections at the drive terminals, take care not stress the IGBTs. The IGBTs are connected to the other end of the terminal bar.

5. After checking that everything is secure, the power can be restored.

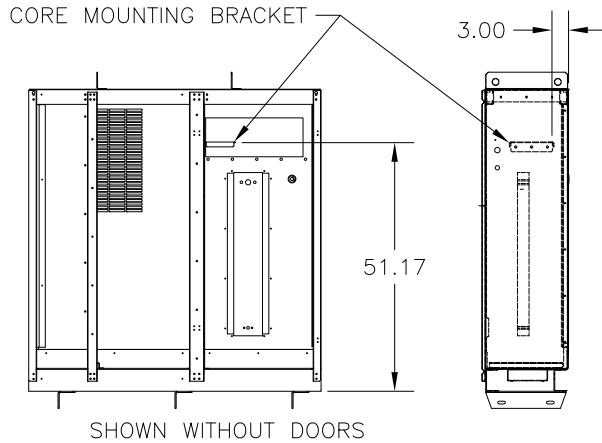
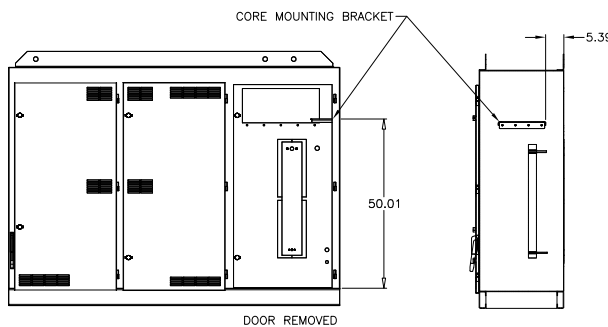
Figure 1. AFDE Unit-Mounted Drive (Frame 3)

Figure 2. AFDE Unit-Mounted Drive (Frame 4)

AFDG Remote-Mounted Drive
⚠ WARNING
Hazardous Voltage w/Capacitors!

Failure to disconnect power and discharge capacitors before servicing could result in death or serious injury. Disconnect all electric power, including remote disconnects and discharge all motor start/run capacitors before servicing. Follow proper lockout/tagout procedures to ensure the power cannot be inadvertently energized. For variable frequency drives or other energy storing components provided by Trane or others, refer to the appropriate manufacturer's literature for allowable waiting periods for discharge of capacitors. Verify with an appropriate voltmeter that all capacitors have discharged.

For additional information regarding the safe discharge of capacitors, see *PROD-SVB06A-EN*

1. Turn off the main power disconnect to the chiller and then follow the correct lockout/tagout safety procedures to ensure that main power to the machine cannot be inadvertently restored.
 - a. For additional safety, also open all starter and control panel disconnect switches and secure them in the open position.
 - b. Follow proper safety procedures to assure that the capacitors in the drive have been discharged and then verify that no power exists in the drive cabinet.
2. Identify and clearly label the drive output terminals and motor power cables. The existing motor power cables can now be disconnected at the drive output terminals.
3. Secure the bracket to the drive cabinet using the provided hardware. Refer to [Figure 3, p. 7](#) and [Figure 4, p. 7](#) for the recommended mounting locations for your particular application.
 - a. Set the magnetic cores onto the shelf and secure them into place using the supplied cable ties.

Note: You may want to wait to secure the cores to the bracket to make it easier to install the motor leads.
4. Route the existing motor power cables through the center of the cores and secure to the proper terminals at the drive output.
5. After checking that everything is secure, the power can be restored.

Figure 3. AFDG Remote-Mounted Drive (Frame D3 and D4)

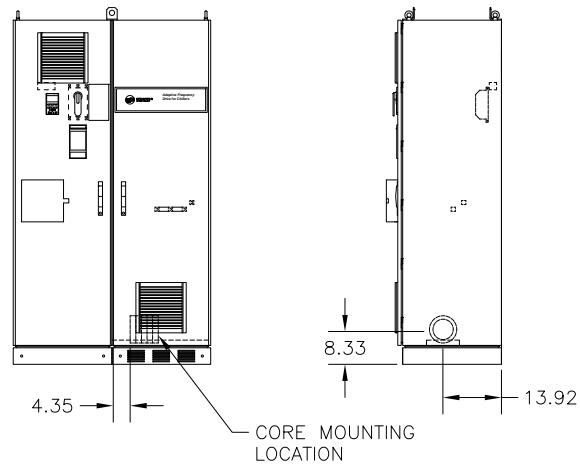

Figure 4. AFDG Remote-Mounted Drive (Frame E2)

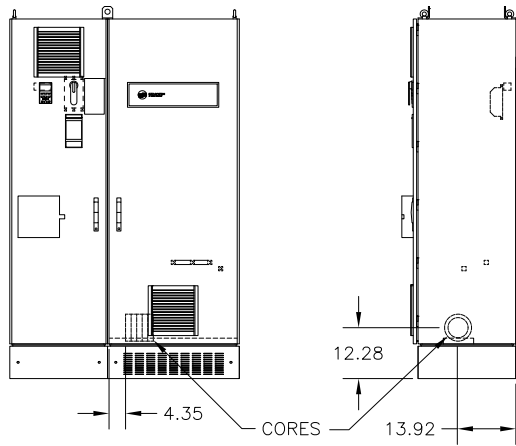
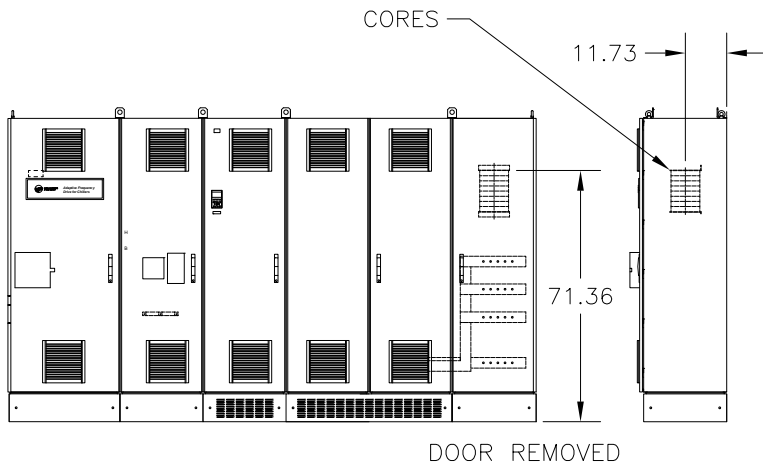

Figure 5. AFDG Remote-Mounted Drive (Frame F3 and F4)



Trane - by Trane Technologies (NYSE: TT), a global climate innovator - creates comfortable, energy efficient indoor environments for commercial and residential applications. For more information, please visit trane.com or tranetechnologies.com.

Trane has a policy of continuous product and product data improvement and reserves the right to change design and specifications without notice. We are committed to using environmentally conscious print practices.