



Installation Manual

Split System (R-410A)
Inverter Unit 15 SEER
9,000 to 24,000 BTU/Hr - 60 Hz



	<u>Indoor Unit</u>	<u>Outdoor Unit</u>
Cooling only	4MYW4-A	4TYK4-A
Heat pump	4MXW4-A	4TXK4-A

⚠ WARNING

Only qualified personnel should install and service the equipment. The installation, starting up, and servicing of heating, ventilating and air-conditioning equipment can be hazardous and requires specific knowledge and training. Improperly installed, adjusted or altered equipment by an unqualified person could result in death or serious injury. When working on the equipment, observe all precautions in the literature and on the tags, stickers and labels that are attached to the equipment.

Warnings and Cautions

Warnings and Cautions. Notice that warnings and cautions appear at appropriate intervals throughout this manual. Warnings are provided to alert installing contractors to potential hazards that could result in personal injury or death, while cautions are designed to alert personnel to conditions that could result in equipment damage.

Your personal safety and the proper operation of this machine depends upon the strict observance of these precautions.

Read this manual thoroughly before operating or giving service to this unit.

ATTENTION: Warnings and Cautions appear at appropriate sections throughout this literature. Read these carefully:

- ⚠ WARNING** Indicates a potentially hazardous situation which, if not avoided, could result in death or serious injury.
- ⚠ CAUTION** Indicates a potentially hazardous situation which, if not avoided, could result in minor or moderate injury. It may also be used to alert against unsafe practices.
- NOTICE:** Indicates a situation that could result in equipment or property damage only accidents.

⚠ WARNING

Ground Required!

Follow proper local electrical code on requirements for grounding. Failure to follow code could result in death of serious injury.

⚠ WARNING

R410A Refrigerant under Higher Pressure than R22!

The units described in this manual use R410A refrigerant which operates at 50 to 70% higher pressures than R-22. Use only R-410A approved service equipment. Refrigerant cylinders are painted with "pink" color to indicate the type of refrigerant and may contain a "dip" tube to allow for charging of liquid refrigerant into the system. For specific handling concerns with R-410A, contact your local Trane representative.

Failure to use R-410A approved service equipment could result in standard equipment exploding under R-410A higher pressure which could result in death or serious injury.

⚠ WARNING

This information is intended for use by individuals possessing adequate backgrounds of electrical and mechanical experience. Any attempt to repair a central air conditioning product may result in death, personal injury or property damage. The manufacturer or seller cannot be responsible for the interpretation of this information, no can it assume any liability in connection with its use.

NOTICE

Use PVE Oil with R-410A Mini-Split units!

All R-410A mini-splits use a PVE oil (Polyvinyl Ether Oil) that readily absorbs moisture from the atmosphere. To limit this "hygroscopic" action, the system should remain sealed whenever possible. If a system has been open to the atmosphere for more that 4 hours, the compressor oil must be replaced. Never break a vacuum with air and always change the driers when opening the system for component replacement. For specific handling concerns with PVE oil, contact your local Trane representative.

USE ONLY THE FACTORY RECOMMENDED - DAFNE HERMETIC OIL FV50S - for servicing these units.

Failure to follow these recommendations could result in equipment damage.

Important!

Environmental Concerns - Scientific research has shown that certain man-made chemicals can affect the earths naturally occurring stratospheric ozone layer when released to the atmosphere. In particular, several of the identified chemicals that may affect the ozone layer are refrigerants that contain Chlorine, Fluorine and Carbon (HCFCs). Not all refrigerants containing these compounds have the same potential impact to the environment. Trans advocates the responsible handling of all refrigerants - including industry replacements for CFCs such as HCFCs and HFCs.

Responsible Refrigerant Practices - Trane believes that responsible refrigerant practices are important to the environment, our customers and the air-conditioning industry. All technicians who handle refrigerants must be certified. The Federal Clean Air Act (Section 608) sets forth the requirements for handling, reclaiming, recovering and recycling of certain refrigerants and the equipment that is used in these service procedures. In addition, some states or municipalities may have additional requirements that must also be adhered to for responsible management of refrigerants. Know the applicable laws and follow them.

Content

General Information.....	5
Accessories.....	6
Typical Installation.....	7
Installation Location.....	8
Indoor Unit/Outdoor Unit.....	9
Vacuum Pump and Leak Inspection.....	13
Outdoor Condensation Drainage (heat pump only).....	14
Connection Pipe.....	16
Wiring Diagrams.....	17

General Information

This installation manual is given as a guide to good practices in the installation and operation of wall-mounted split system models 4MYW4 and 4TYK4; 4MXW4 and 4TXK4. However, it does not contain all the service procedures for this unit. These procedures must be performed by a qualified service technician through a maintenance contract with a reputable service company. Read these operation instructions thoroughly before installing the unit.

Warranty

Warranty is based on the general terms and conditions by country. The warranty is voided if the equipment is modified or repaired without the written approval of The Trane Company, and if the operating limits are exceeded or if the control system or the electric wiring is modified.

Damage due to inappropriate installation, lack of knowledge or failure to comply with the manufacturer's instructions, is not covered by the warranty obligation.

If the installation does not conform to the rules described in the Installation Manual, it may entail cancellation of warranty and liabilities by The Trane Company.

Reception

On arrival, inspect the unit before signing the delivery note. Specify any damage on the unit on the delivery note and send a registered letter of protest to the last carrier of the goods within 71 hours of delivery. Notify the dealer at the same time.

The unit should be totally inspected with 7 days of delivery. If any concealed damage is discovered, send a registered letter of protest to the carrier within 7 days of delivery and notify your local dealer.

About the Unit

These units are assembled, pressure tested, dehydrated, charged and run-tested before shipment. This manual contains information related to 4MYW4 and 4TYKW4; 4MXW4 and 4TXK4.

Refrigerant









The refrigerant provided by the manufacturer must comply with all the requirements for our units. When using a recycled or reprocessed refrigerant, we recommend its quality to be as good as that of a new refrigerant. Have the refrigerant tested by a qualified laboratory. Failure to do so could void the warranty.

Important

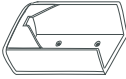
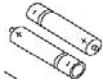
These instructions do not cover all variations in systems, nor do they provide for every possible contingency to be met in connection with the installation. Should further information be desired or should particular problems arise which are not covered sufficiently in this manual, the matter should be referred to your authorized Trane dealer.

Accessories

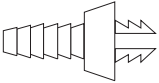
Table 1. Parts list

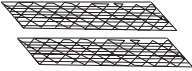
No.	Part Name	Diagram	Qty	Specification	Memo
1	Mounting plate		1		
2	Wireless remote controller		1		
3	Remote controller holder		1		
4	Battery		2	AAA, 1.5V	
5	Tapping screw		0~10	ST4.2 X 25	For mounting plate
6	Drain hose		1	L = 2m	
7	Thermal insulation		1		
8	Drain kit		1		Heat pump type only
9	Drain hole cover		3		Heat pump type only
10	Air cleaner		2		
11	Air filter		2		

Model Numbers

High Efficiency (15 SEER), R410A - 60Hz

Cooling Only

Indoor Units

4MYW4509A1

4MYW4512A1

4MYW4518A1

4MYW4524A1

Outdoor Units

4TYK4509A1

4TYK4512A1

4TYK4518A1

4TYK4524A1

Heat Pump

Indoor Units

4MXW4509A1

4MXW4512A1

4MXW4518A1

4MXW4524A1

Outdoor Units

4TXK4509A1

4TXK4512A1

4TXK4518A1

4TXK4524A1

Installation

Names and functions of each part

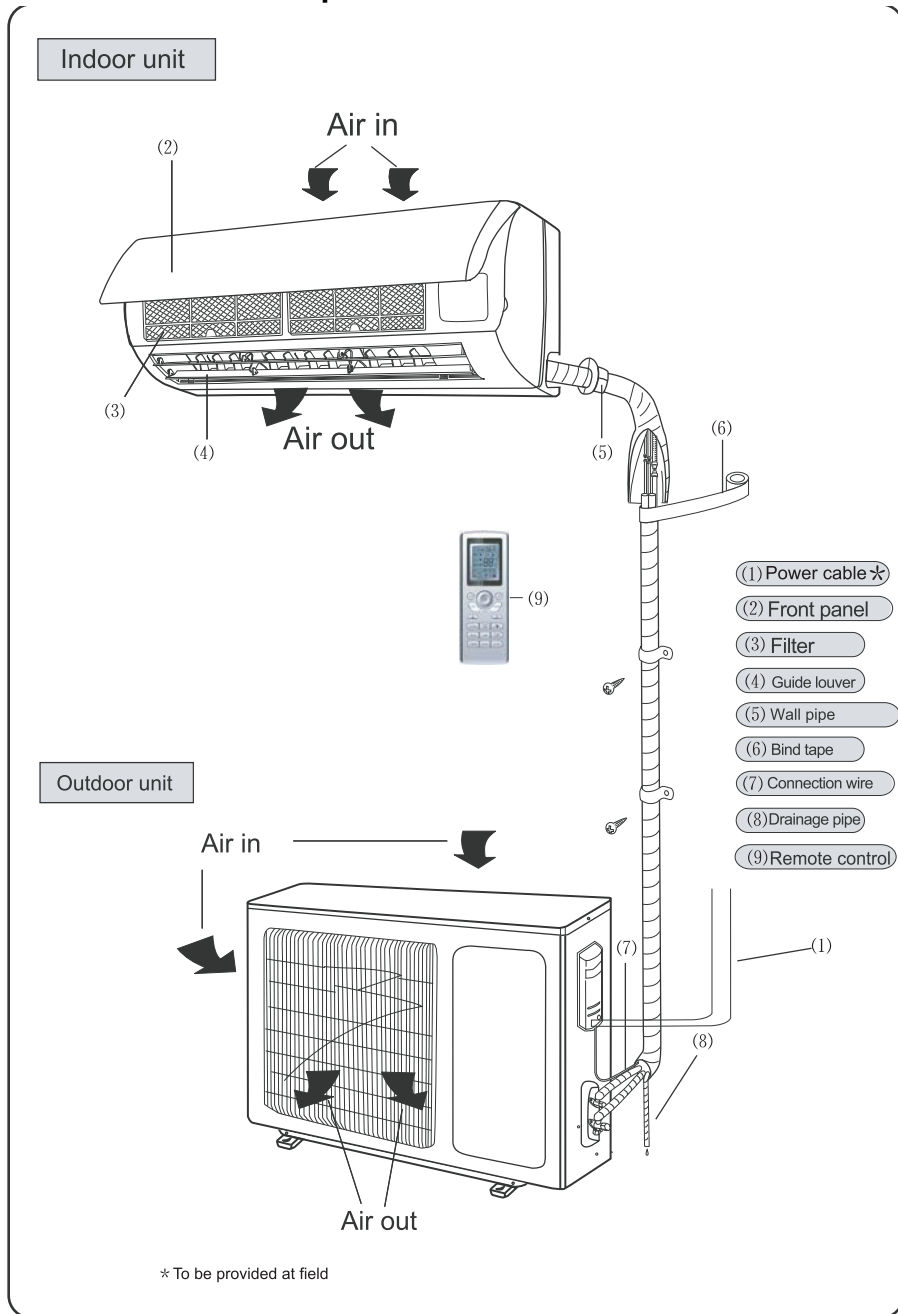

Installation location

Indoor Unit

WARNING!

Adequate Support

Wall structure must be adequate to support the weight of the unit. Failure to ensure adequate structural support could result in unit falling from its location which could result in death, serious injury, or equipment or property-only damage.

1. The air inlet and outlet should be far away from anything that could prevent the air from reaching all parts of the room
2. Select a location where it is easy to drain the condensing water and connect to the outdoor unit
3. Keep the indoor unit far away from heat sources, vapor and inflammable gas
4. Be sure that the installation of the indoor unit conforms to the installation dimension diagram
5. Be sure to leave enough space to allow access for routine maintenance; clearance between the indoor unit and the floor should be more than 7 feet
6. Install in a location where the unit is more than 3 feet away from other electric appliances such as television, auto devices, etc.
7. Select a location where air filters can be easily removed.

Outdoor Unit

WARNING!

Adequate Support

Wall structure must be adequate to support the weight of the unit. Failure to ensure adequate structural support could result in unit falling from its location which could result in death, serious injury, or equipment or property-only damage.

1. Select a location from which noise and air discharge by unit will not annoy neighbors
2. Select a location where there is sufficient ventilation
3. Make sure the air inlet and outlet are not blocked by any obstacles
4. Select a location capable of supporting the weight and vibration of the outdoor unit and where installation work can be carried out safely
5. Select a location away from flammable gas or gas leaks
6. Make sure that the installation of the outdoor unit conforms to the installation dimension diagram.

NOTICE

Installing the unit in one of the following locations could result in unit malfunction:

- Places where oil (machine oil) is used
- Seaside areas with high level of salt in the air
- Places with high level of sulfur gas such as areas with hot springs
- Places where high frequency waves are generated by radio equipment, welders and medical equipment
- Other unusual places where unit operation may be altered.

Indoor Unit Installation Against the Wall

Mounting Plate

Install mounting plate horizontally and perfectly levelled.

Secure the plate with screws provided with the unit.

Ensure that the mounting plate will support the weight of 60 kg. This weight must be evenly shared by each screw.

If the wall is made of brick or concrete, drill 8 holes into it, each of a 5mm diameter. Use anchor fasteners for the appropriate bolts.

Figure 1. Mounting Plate Installation

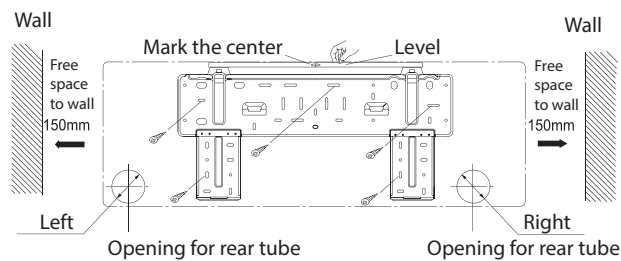

Perforations in the Wall for Piping

Piping can be connected in 6 different directions shown as follows:

Figure 2. Piping directions

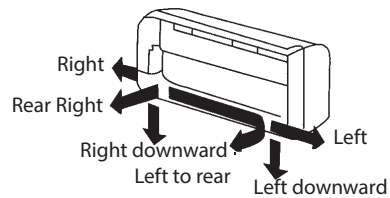

Drill a 65mm diameter hole in the wall, if the units is up to 18MBH, or a 95mm diameter hole if the unit is up to above 18MBH. The perforation should show a slight downward inclination with direction towards the outdoor side in such a way that the end of the pipe is at least 55mm lower than the interior end.

Insert a protective wall sleeve in the perforation to prevent damages to the connective piping and wiring while it passes through the hole in the wall.

Figure 3. Protective pipe sleeve

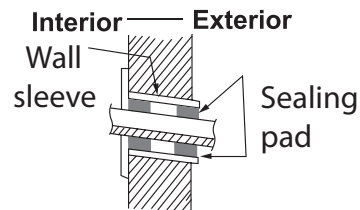

Note: In cases when a wall pipe sleeve is not used, always perform the wall perforation in a straight and uniform manner. If the center of the hole is not properly aligned, it could give way to condensate leaking.

Note: If a wall pipe sleeve is not used, the wiring that connects the indoor unit to the outdoor unit could rub against each other and lead to electrical current leaking to ground.

Drain Hose Installation

1. For better draining, the hose should be installed with a downward inclination.
2. Do not bend or exercise pressure over the hose; do not allow the final end of the hose to remain submerged under water. See figure below.
3. The entire length of the indoor drain hose should be wrapped around with insulation.

Figure 4. Drain Hose

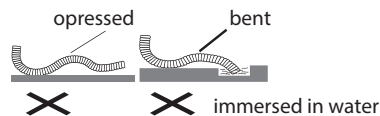

Hanging the Unit on the Wall

1. While directing piping and wiring either from the right side or left side of the unit, remove the perforated sections from the chassis as required.
 - Remove section 1 when directing wiring only;
 - Remove both sections 1 and 2 when directing piping and wiring (or rather, 1, 2, 3).

Figure 5. Chassis perforations

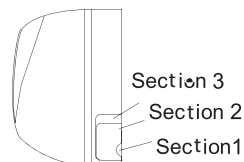

2. With the use of tape, wrap and tie piping and wiring together forming a bundle and insert whole bundle through the hole recently perforated for this purpose.

Figure 6. Piping bundle

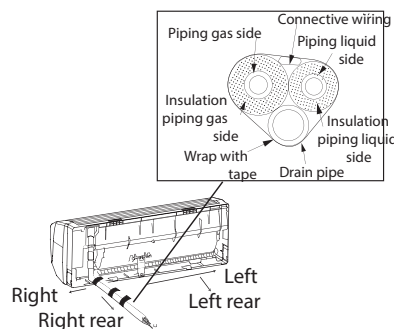

3. Hang the mounting slots of the indoor unit on the upper tabs of the rear panel and ascertain their firmness.

Figure 7. Hanging the Unit

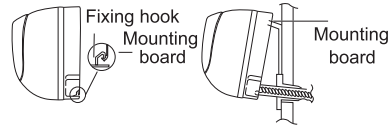

Installing connection pipe

1. Align the center of the piping flare with the respective valve. See following figure.

Figure 8.

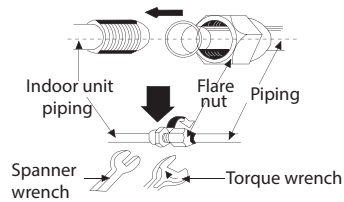

2. Fasten the flared nut manually and then tighten the nut using a spanner wrench or a torque wrench.

Table 1. Tightening torque

Hex nut diameter	Tightening torque (N-m)
6mm - 1/4"	15-20
9.5mm - 3/8"	31-35
12mm - 1/2"	50-55
16mm - 5/8"	60-65

Note: First connect the connection pipe to the indoor unit; then connect to the outdoor unit. Be careful not to damage or bend the connection pipe. In order to avoid future leaking, do not over-tighten the nut.

Connecting Electric Wiring Between Indoor and Outdoor Units

WARNING

⚠ Hazardous Voltage!

Disconnect all electric power, including remote disconnects, before servicing. Follow proper lockout/tagout procedures to ensure the power cannot be inadvertently energized. Failure to disconnect power before servicing could result in death or serious injury.

1. Open the front panel of the indoor unit by lifting upward.
2. Unscrew and remove the cover plate.
3. Pull the power connection cable through the back of the indoor unit.
4. Firmly attach the power connection cables to the terminal block in the indoor unit, making sure to observe the proper terminal connections as shown on the unit wiring diagram.
5. Reattach the cover plate with the appropriate screws.
6. Fasten the electric wiring within the control panel using a wire clip. In the case of heat pumps, the signal control wire must be connected to the terminal block using a wire clip.

Wiring of Outdoor Unit

WARNING

⚠ Hazardous Voltage!

Disconnect all electric power, including remote disconnects, before servicing. Follow proper lockout/tagout procedures to ensure the power cannot be inadvertently energized. Failure to disconnect power before servicing could result in death or serious injury.

1. Disassemble handle of right side plate or front side plate of outdoor unit.
2. Remove wire clamp, connect and attach power wiring cord to terminal block. Wiring should match that of the indoor unit.
3. Using a wire clamp, attach the power wiring cord inside the control panel for cooling and heating unit; use the wire clamp to attach the signal control wire; next connect the corresponding connector.
4. Ensure wiring has been attached appropriately.
5. Reinstall handle or front side plate.

Note: *Wrong wiring may cause a mal function of components.*

Vacuum Pump and Leak Testing

WARNING

⚠ Hazard of Explosion!

Never use an open flame to detect gas leaks. Explosive conditions may occur. Use a leak test solution or other approved methods for leak testing. Failure to follow recommended safe leak test procedures could result in death or serious injury or equipment or property-only damage.

WARNING

⚠ Hazard of Explosion!

Use only dry nitrogen with a pressure regulator for pressurizing unit. Do not use acetylene, oxygen or compressed air or mixtures containing them for pressure testing. Do not use mixtures of a hydrogen containing refrigerant and air above atmospheric pressure for pressure testing as they may become flammable and could result in an explosion. Refrigerant, when used as a trace gas, should only be mixed with dry nitrogen for pressurizing units. Failure to follow these recommendations could result in death or serious injury or equipment or property-only damage.

After the installation of refrigerant lines to both the outdoor and indoor units are completed, the flare connections must be checked for leaks. Through the service valve ports, pressurize the indoor unit and field refrigerant lines with dry nitrogen to 350-400 psi. Use soap bubbles or other leak-checking methods to see that all flares are leak free. If not, release pressure; then repair.

System Evacuation

Note: *Since the outdoor unit has a refrigerant charge, the gas and liquid line valves must remain closed.*

1. Upon completion of leak check, evacuate the refrigerant lines and indoor coil before opening the gas and liquid line valves.
2. Attach appropriate hoses from manifold gauge to gas and liquid line pressure taps.
3. Attach center hose of manifold gauge to vacuum pump.
4. Evacuate until the micron gauge reads no higher than 250 microns.
5. Close off valve to vacuum pump and observe the micron gauge. If gauge pressure rises above 500 microns in one minute (1) then evacuation is incomplete or system has a leak.
6. If vacuum gauge does not rise above 500 microns in one (1) minute, the evacuation should be complete.
7. Blank off vacuum pump and micron gauge and close valves on manifold gauge set.

Note: *DO NOT VENT REFRIGERANT INTO THE ATMOSPHERE.*

8. The liquid line shut-off valve can now be opened. Remove shut-off valve cap. Fully insert hex wrench into the stem and back-out counterclockwise open.

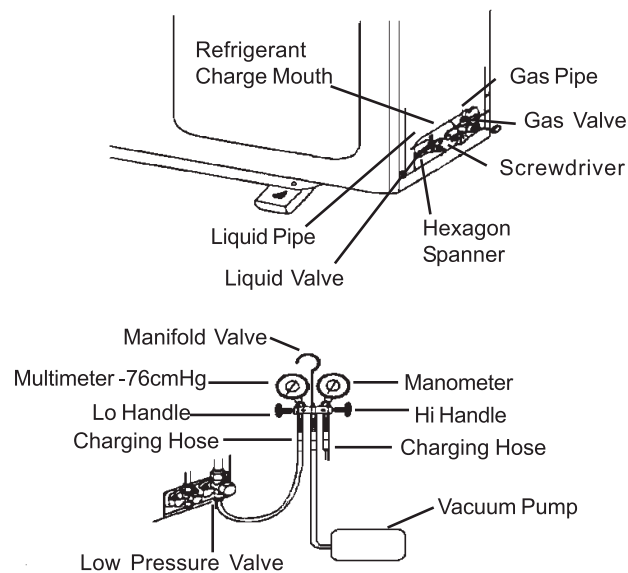
Figure 9. Vacuum Pump and Leak Inspection

Note: Gauge must be R410A rated.

9. The gas valve can now be opened. Open the gas valve by removing the shut-off valve cap and turning the valve stem 1/4 turn counterclockwise using 1/4" Open End or Adjustable wrench.
10. The gas valve is now open for refrigerant flow. If refrigerant lines are longer than fifteen feet (8m), it will be necessary to adjust system refrigerant charge upon completion of installation.

Outdoor Condensation Drainage (Heat Pump type only)

When the unit is heating, the condensing water and defrosting water can be drained out reliably through the drain hose.

Installation:

Install the outdoor drain kit in a 25mm hole on the base plate and join the drain hose to the kit to permit the condensed water to be drained out to a proper place.

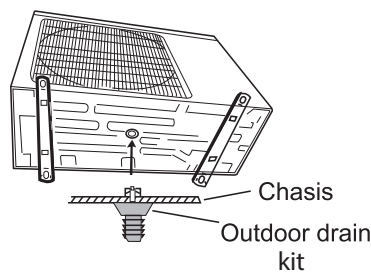
Figure 10. Drain Kit

Installation Verification and Run Test

Items to verify:	Possible problems they generate:
Has the indoor unit been firmly installed?	The unit may drop, shake or emit noise
Have you done the refrigerant leak test?	It may cause insufficient cooling/heating capacity
Is thermal insulation sufficient?	It may cause condensation and dripping
Does the unit drain appropriately?	It may cause condensation and dripping
Is the voltage in accordance with the rated voltage marked on the nameplate?	It may cause electric malfunction or damage the unit
Is the electric wiring and piping connection installed correctly and securely?	It may cause electric malfunction or damage the unit
Has the unit been connected to a secure earth connection?	It may cause electric current leakage
Has the proper power cord been specified?	It may cause electric malfunction or damage to unit
Has the inlet and the outlet been covered?	It may cause insufficient cooling/heating capacity
Has the length of connection pipes and refrigerant charge been recorded?	Refrigerant charge will be inadequate

Before run test

Do not apply power before installation has been completed.

Electric wiring must be connected correctly and securely.

Connection piping shut-off valves should be in open position.

The unit must be rid of all debris and scrap.

Run test

Press the "ON/OFF" button on the wireless remote control to initiate operation.

Press the MODE button to select COOL, HEAT, FAN to verify the normal operation of the unit.

Table 2. Connection piping

15 SEER (60hz)	4MYW4509A1 4TYK4509A1	4MXW4509A1 4TXK4509A1	4MYW4512A1 4TYK4512A1	4MXW4512A1 4TXK4512A1	4MYW4518A1 4TYK4518A1	4MXW4518A1 4TXK4518A1	4MYW4524A1 4TYK4524A1	4MXW4524A1 4TXK4524A1
Refrigerant Charge (kg)	0.74	0.74	1	1	1.2	1.8	1.6	1.85
Length (m)	7.5	7.5	7.5	7.5	7.5	7.5	7.5	7.5
Additional Gas Charge (g/m)	15	20	15	20	15	20	15	20
Outer Diameter	Liq. pipe (mm)	φ6 (1/4")	φ6 (1/4")	φ6 (1/4")	φ6 (1/4")	φ6 (1/4")	φ6 (1/4")	φ6 (1/4")
	Gas pipe (mm)	φ9.52 (3/8")	φ9.52 (3/8")	φ9.52 (3/8")	φ9.52 (3/8")	φ12 (1/2")	φ12 (1/2")	φ16 (5/8")
Max. Distance	Height (m)	10	10	10	10	10	10	10
	Length (m)	15	15	20	20	25	25	25

Wiring Diagrams

WARNING

¡Hazardous Voltage!

Disconnect all electric power, including remote disconnects, before servicing. Follow proper lockout/tagout procedures to ensure the power cannot be inadvertently energized. Failure to disconnect power before servicing could result in death or serious injury.

WARNING

Electrocution and Fire Hazards with Improperly Installed and Grounded Field Wiring!

Improperly installed and grounded field wiring poses fire and electrocution hazards. To avoid these hazards, you must follow requirements for field wiring installation and grounding as described in the National Electrical Codes (NEC) and your local/state electrical codes. All field wiring must be performed by qualified personnel. Failure to comply with these requirements could result in death or serious injury.

Figure 11. MYW4509A1 4MYW4512A1 Cooling Only Indoor U.-- 4MXW4509A1 4MXW4512A1 Heat Pump Indoor U.

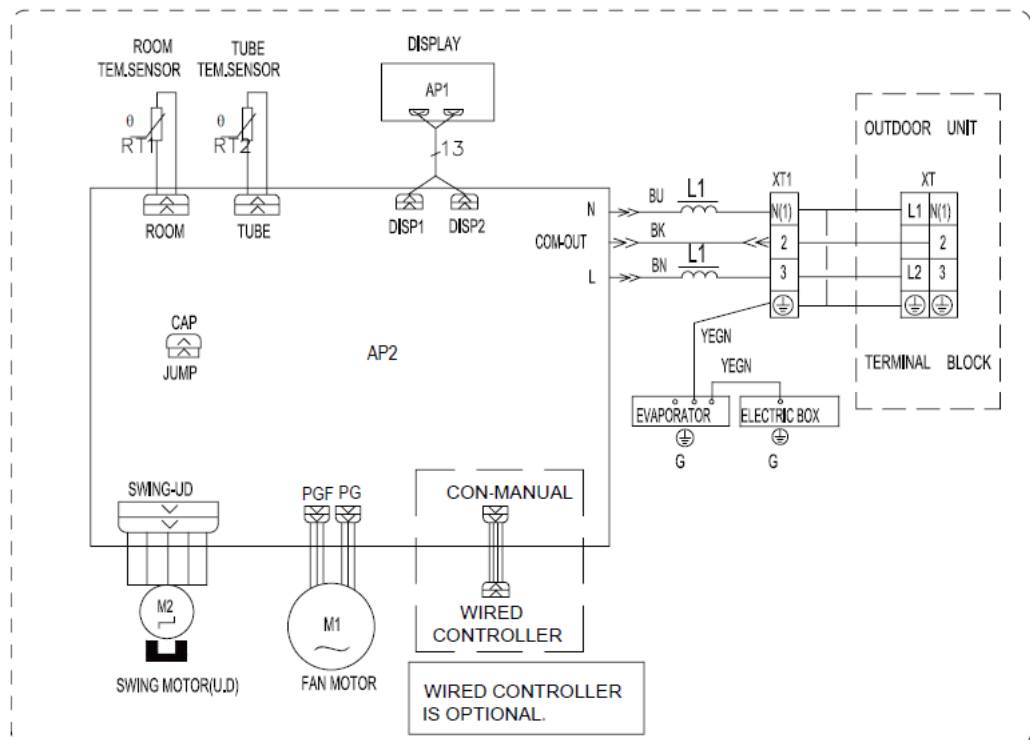

Figure 12. 4MYW4518A1 Cooling Only Indoor U./ 4MXW4518A1 Heat Pump Indoor U.

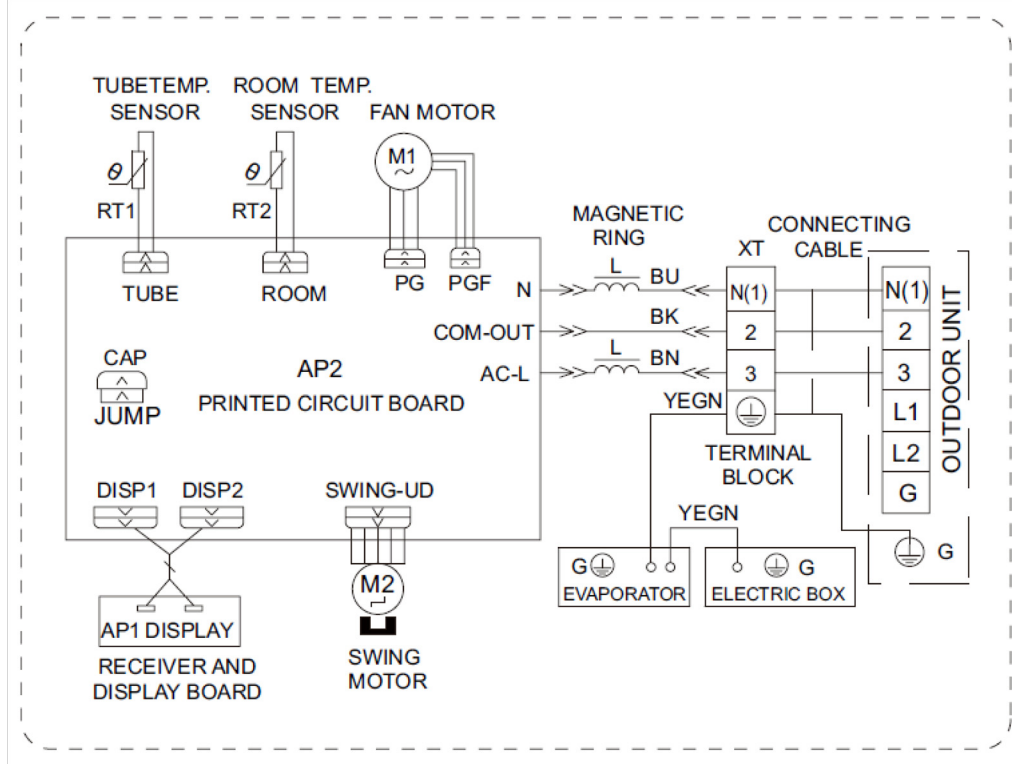

Figure 13. 4MYW4524A1 Cooling Only Indoor Units

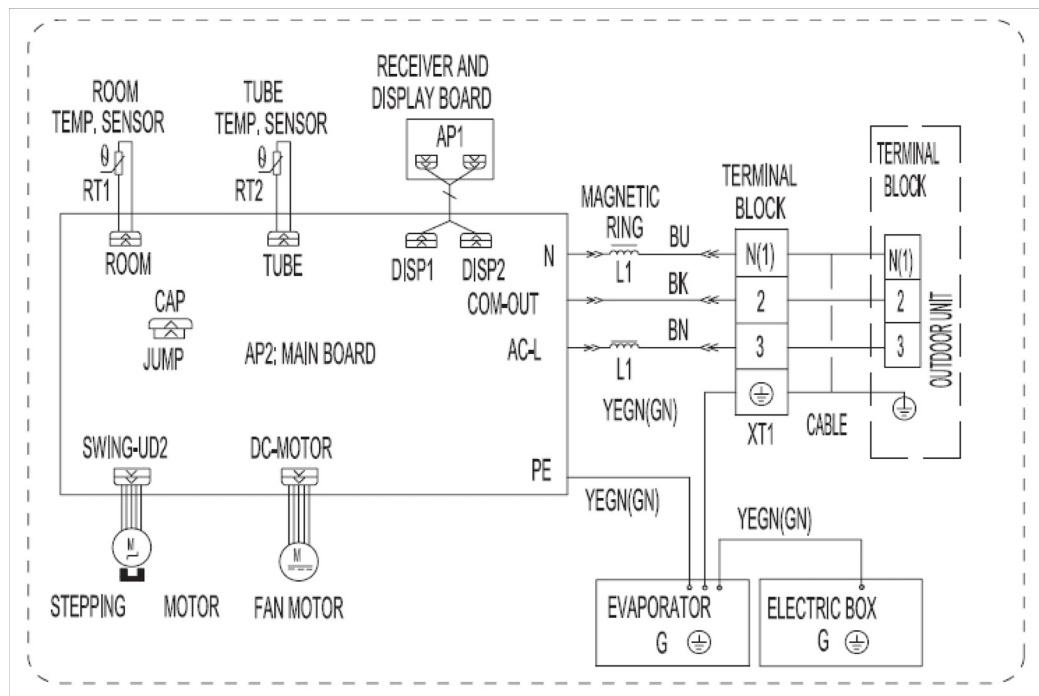

Figure 14. 4MXW4524A1 Heat Pump Indoor Units

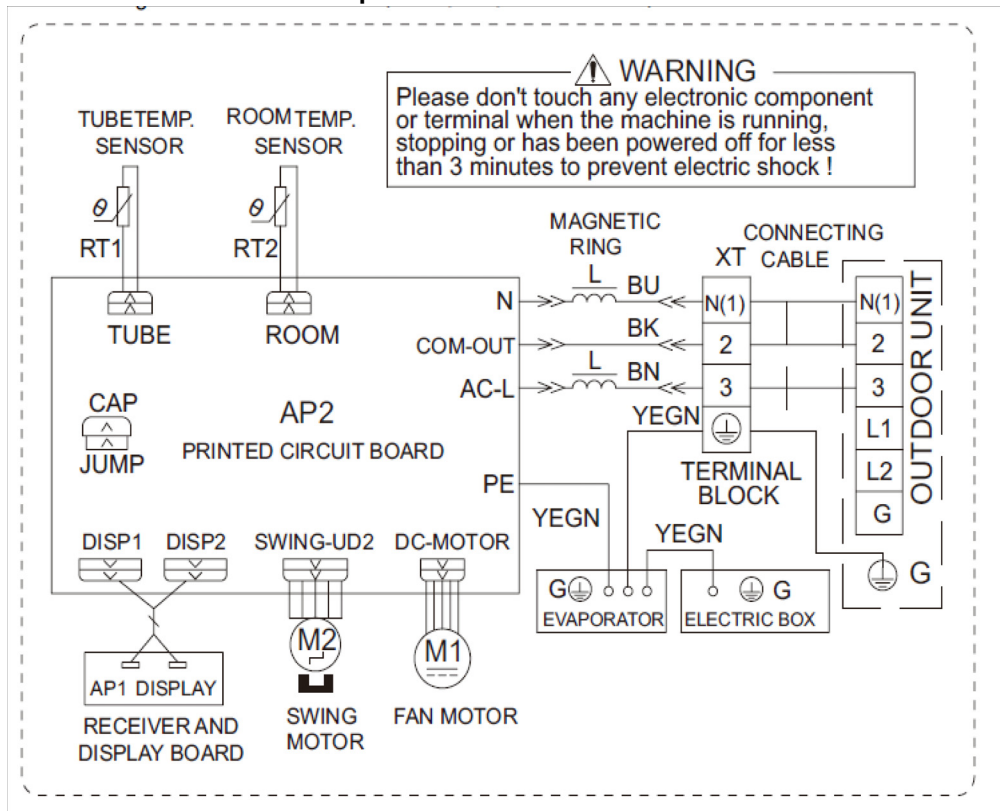

Figure 15. 4TYK4509A1 / 4TYK4512A1 Cooling Only Outdoor Units

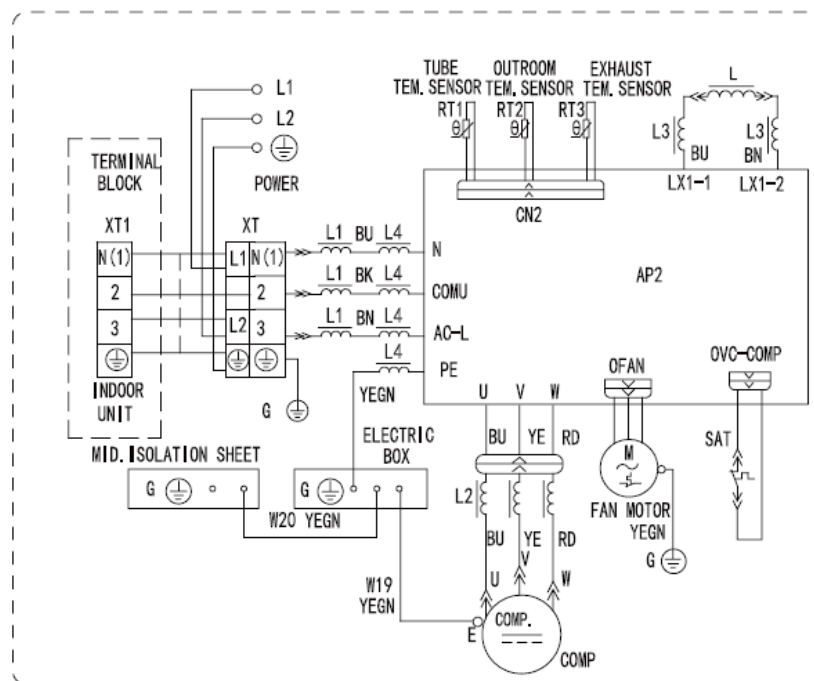

Figure 16. 4TXK4509A1 / 4TXK4512A1 Heat Pump Outdoor Units

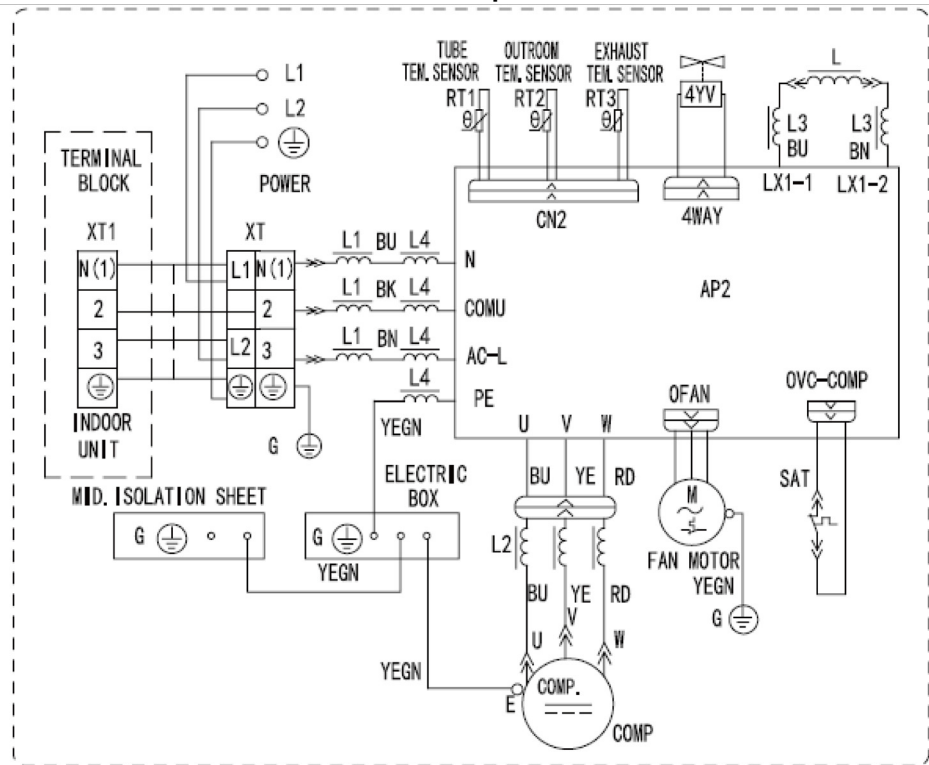

Figure 17. 4TYK4518A1 / 4TYK4524A1 Cooling Only Outdoor units

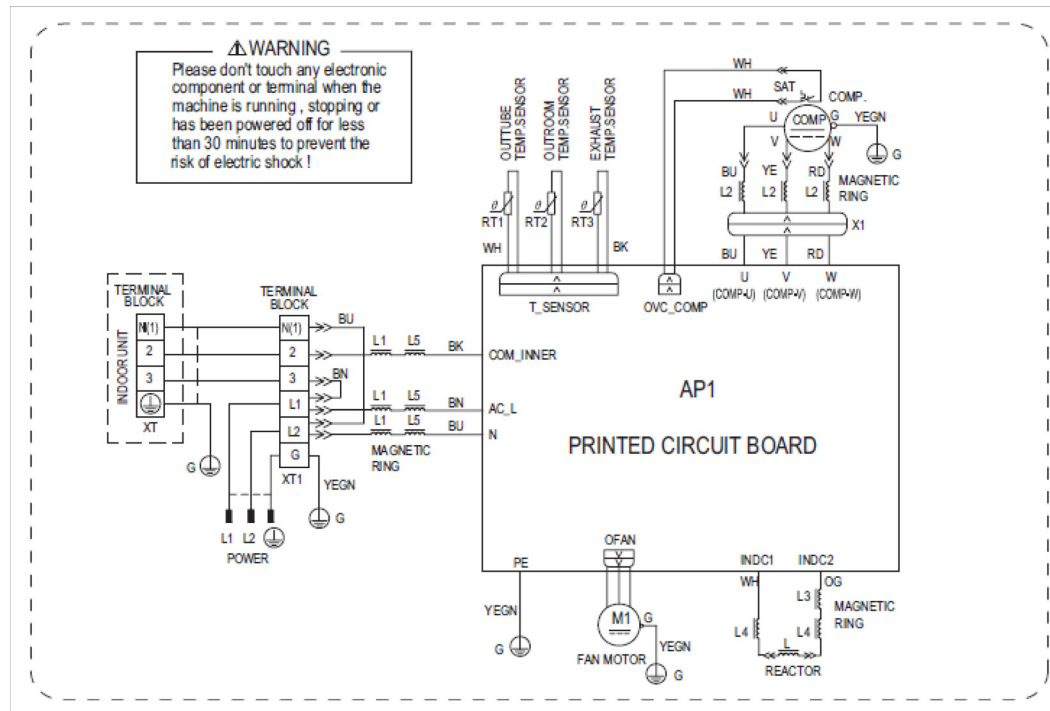
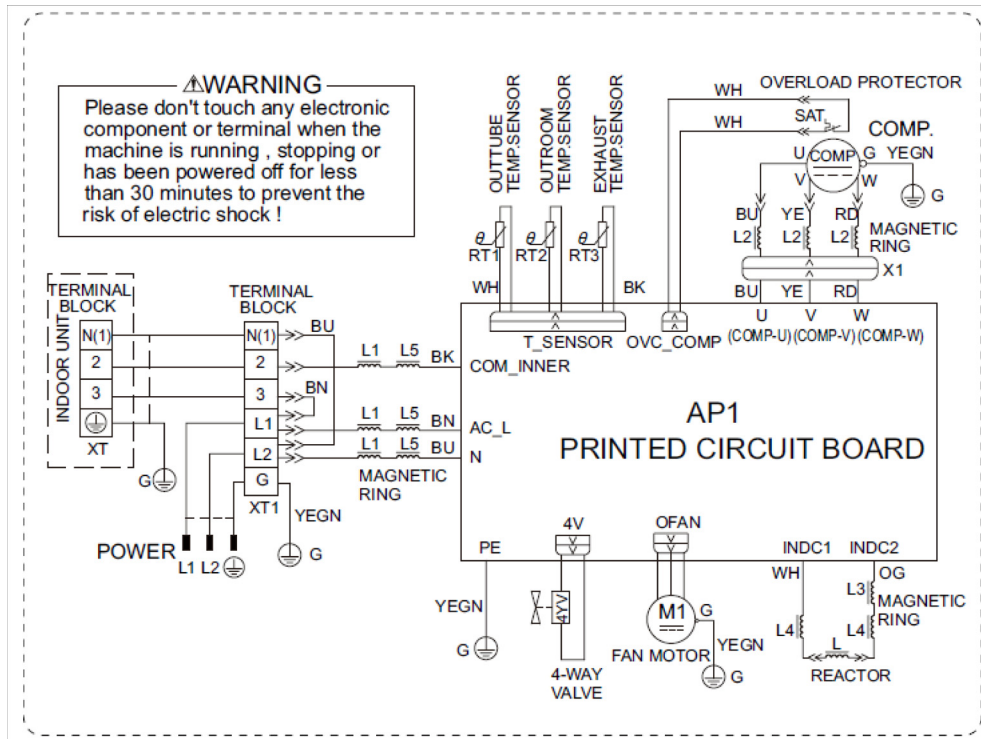

Figure 18. 4TXK4518A1 / 4TXK4524A1 Heat Pump Outdoor Units



Recommended Cable Size

Models with power supply from the outdoor unit to the indoor unit.

9K / 12K

Cable type	Cable size	Description of cable size
Power supply cable	AWG18	One thread copper cable; approx. outer dia. 102mm
Cable between Indoor unit and Outdoor unit	AWG18	One thread copper cable; approx. outer dia. 102mm

18K / 24K

Tipo de cable	Tam. cable	Description of cable size
Power supply cable	AWG14	One thread copper cable; approx. outer dia. 164mm
Cable between Indoor unit and Outdoor unit	AWG18	One thread copper cable; approx. outer dia. 102mm.



Ingersoll Rand (NYSE:IR) advances the quality of life by creating comfortable, sustainable and efficient environments. Our people and our family of brands work together to enhance the quality and comfort of air in homes and buildings; transport and protect food and perishables; and increase industrial productivity and efficiency. We are a global business of \$13 billion committed to a world of sustainable progress and enduring results.

Trane has a policy of continuous product and product data improvement and reserves the right to change design and specifications without notice.