



Instructions for Drilling and Assembling Flex Shaft™ Handle Mechanism for L, M, MDL, N, and R-Frame Series C Circuit Breakers, Molded Case Switches, and HMCP's



WARNING

DO NOT ATTEMPT TO INSTALL OR PERFORM MAINTENANCE ON EQUIPMENT WHILE IT IS ENERGIZED. SEVERE PERSONAL INJURY, DEATH, OR SUBSTANTIAL PROPERTY DAMAGE CAN RESULT FROM CONTACT WITH ENERGIZED EQUIPMENT. ALWAYS VERIFY THAT NO VOLTAGE IS PRESENT BEFORE PROCEEDING WITH THE TASK, AND ALWAYS FOLLOW GENERALLY ACCEPTED SAFETY PROCEDURES.

CUTLER-HAMMER IS NOT LIABLE FOR THE MISAPPLICATION OR MISINSTALLATION OF ITS PRODUCTS.

The user is cautioned to observe all recommendations, warnings and cautions relating to the safety of personnel and equipment as well as all general local health and safety laws, codes and procedures.

The recommendations and information contained herein are based on Cutler-Hammer's experience and judgment, but should not be considered to be all-inclusive or covering every application or circumstance which may arise. If any questions arise, contact Cutler-Hammer for further information or instructions.

GENERAL INFORMATION

The Shaft handle mechanism provides a means of externally operating the circuit breaker and can be applied to enclosures of varying heights and depths. The handle can be used with NEMA 1, 3R, and 12 enclosure applications, plus NEMA 4 and 4x applications, depending on the accessory components selected. An operating handle, flexible shaft, and mechanism are required for standard application. Three lengths of shafts are available for use with the range of depths of various enclosures (4', 5', and 6'). When selecting the length of the Flexible Shaft, ensure Minimum Bending Radius of 5 inches is maintained to operate properly. The flex shaft assembly is Underwriters Laboratories, Inc. listed under UL File E64983.



WARNING

WHEN INSTALLING A NEW HANDLE MECHANISM, OR A NEW CIRCUIT BREAKER AND HANDLE MECHANISM IN AN EXISTING ELECTRICAL SYSTEM, MAKE SURE THERE IS NO VOLTAGE PRESENT WHERE WORK IS TO BE PERFORMED. SPECIAL ATTENTION SHOULD BE PAID TO REVERSE FEED APPLICATIONS TO ENSURE NO VOLTAGE IS PRESENT. THE VOLTAGE IN ENERGIZED EQUIPMENT CAN CAUSE DEATH OR SEVERE PERSONAL INJURY.

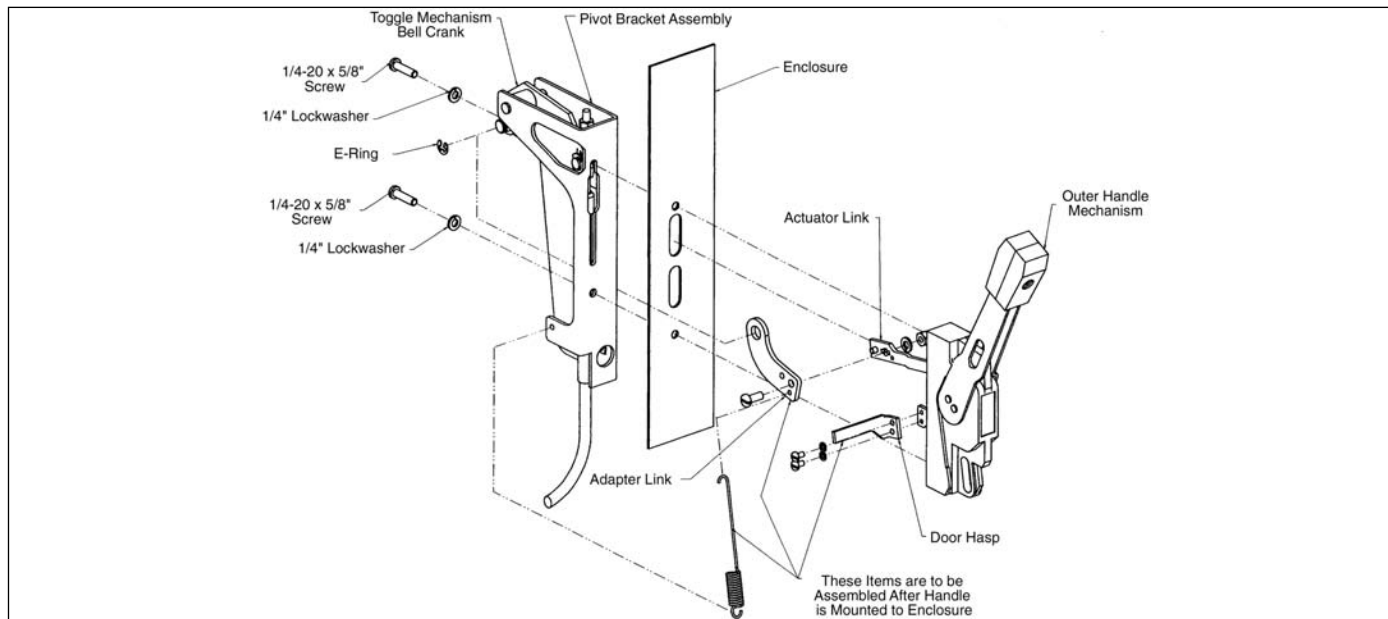

Figure 1-1 Pivot Bracket and Outer Handle Mechanism Assembly

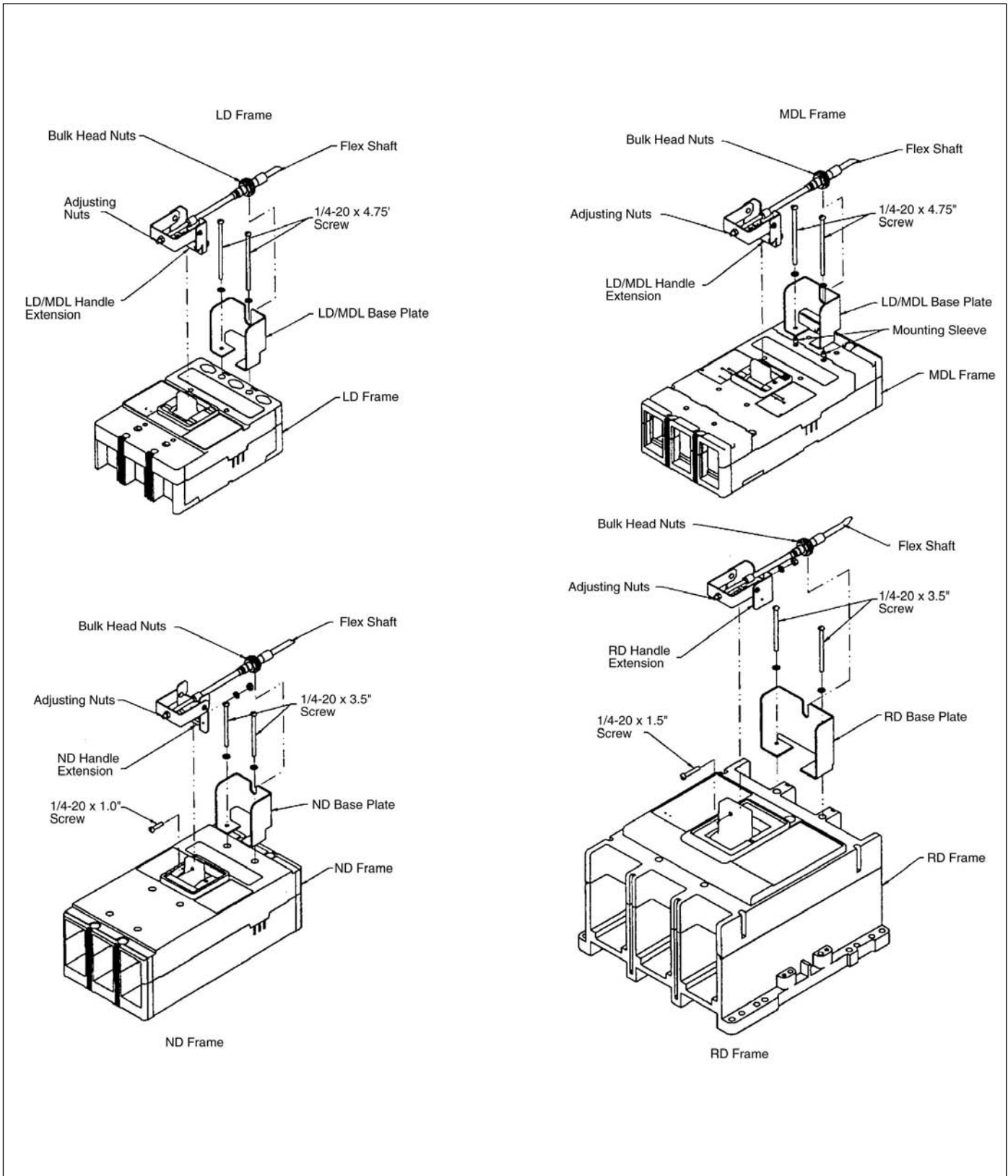

Figure 1-2 LD, MDL, ND, RD Mechanism Assembly

INSTALLATION

1. Remove the two 1/4-20 x 5/8" screws and lockwashers from the outer handle mechanism. Place each screw and lockwasher through the pivot bracket assembly. Thread the retaining washers enclosed in the parts kit onto the 1/4-20 x 5/8" screws. See Figure 1-1.
2. Connect the actuator link from the outer handle mechanism on the pivot bracket assembly. Mount the pivot bracket assembly to the enclosure and outer handle mechanism by securing the mounting hardware. Attach the E-Ring supplied in the parts kit to the actuator link. See Figure 1-1.
3. Drill and tap the mounting holes for the circuit breaker. See breaker frame instruction leaflet for the drilling pattern.

Note: Be certain that there is a 5 inch minimum clearance between the load end of the breaker and wall of the enclosure for the flex shaft.

4. Mount breaker's Line end to enclosure using the mounting hardware supplied in the hardware kit.
5. Attach the base plate and mounting hardware to the load end of the circuit breaker per the following breaker frames:

LD: Attach the base plate and Load end of the breaker to enclosure using the 1/4-20x4.75" screws and lockwashers enclosed. See Figure 1-2 for illustration.

M: Attach the Load end of the breaker to the enclosure using hardware from the hardware kit. Attach the base plate to the Load end cover on the (M) type breaker. The load end cover screws are replaced with the (2) 10-32x2" screws and lockwashers enclosed. (Not shown in Figure 1-2).

MDL: Attach the load end of the breaker to the enclosure using hardware from the hardware kit. Attach the base plate to the load end cover of the breaker. The load end cover screws are replaced with the (2) #8-32x2.25" screws, #8 lockwashers, and mounting sleeves enclosed. See Figure 1-2 for illustration.

ND: Attach the Load end of the breaker to the enclosure using hardware from the hardware kit. Attach the base plate to the circuit breaker using the 1/4-20x3.5" screws and 1/4" lockwashers enclosed in the parts kit at the load end of the breaker after removing the (2) load cover screws located between the trip unit and the two load end mounting holes. See Figure 1-2 for illustration.

RD: Attach the Load end of the breaker to the enclosure using the hardware from the hardware kit. Attach the base plate to the circuit breaker using the 1/4-20x3.75" screws and 1/4" lockwashers enclosed in the parts kit at the load end of the breaker. See Figure 1-2 for illustration.

Note: Prior to Dec. 1994: The Breaker mounting hardware for Line end and Load end mounting (except LD) were in the appropriate breaker frame mounting hardware kit. The mounting hardware is now included in the hardware parts enclosed.

6. Place the outer handle mechanism in the full **ON** position and the circuit breaker in the **ON** position. You must Release Cover interlock to move handle to **ON** position. Place the handle extension assembly onto the breaker handle and secure as shown on Figure 1-2.

Note: LD and MD use clamp type assembly; ND and RD use a through bolt for handle attachment from the hardware kit.

7. Locate bulk head nuts of the flexible shaft over the groove of the base plate and tighten.
8. Actuate the outer handle positions (**ON**, **OFF**, **RESET**). If minor adjustments are necessary, refer to the following adjustment checklist and Figure 1-2.

Install appropriate door hardware (supplied); as referenced on Figure 1-3.

ADJUSTMENT CHECKLIST

Situation:

Breaker turns **ON** and **OFF**, but will not **RESET** when tripped.

Adjustment:

Loosen the 1/4-28 adjusting nut that is closest to the black cap and turn towards the cap about 1.5-2 turns. Retighten the adjusting nut that is on the end of the shaft to the handle extension and inner adjusting nut. Recheck for the **ON**, **OFF** and **RESET** position. If not successful, repeat procedure. If still not successful, and the adjusting nut is bottomed out onto the shaft, loosen the bulk head nuts, and shift the cable towards the Load end of the breaker. Re-tighten the bulk head nuts. Recheck for the **ON**, **OFF** and **RESET** position. If not successful, repeat the beginning steps.

Situation:

Breaker resets after tripping, but does not turn **ON**.

Adjustment:

Loosen the 1/4-28 adjusting nut that is located on the end of the shaft and turn towards the end of the shaft about 1/5-2 turns. Re-tighten the adjusting nut that is closest to the black cap to the handle extension and the outing adjusting nut. Re-check for the **ON**, **OFF** and **RESET** position. If not successful, and the adjusting nut on the end of the shaft is two threads from the end, loosen the bulk head nuts, and shift the cable towards the line end of the breaker. Re-tighten the bulk head nuts. Re-check for the **ON**, **OFF** and **RESET** position. If not successful, repeat the beginning steps.

If any other adjustment problems should arise, contact your local Cutler-Hammer representative.

AMT-Vari-Depth Handle Mechanisms (Dimensions in Inches)
 Outline and Drilling Plans
 For Enclosure Door Interlock Assembly

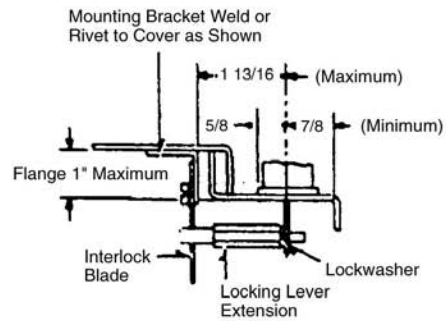
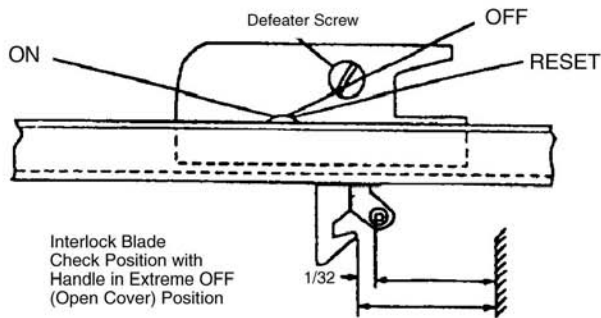
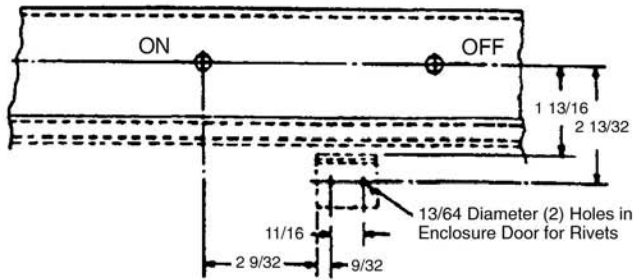

External Handle

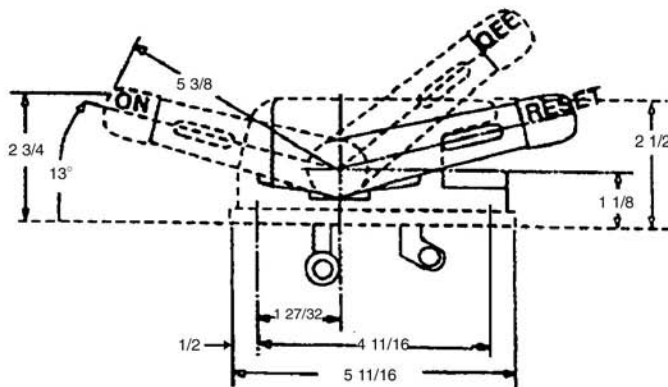

For Handle Flange

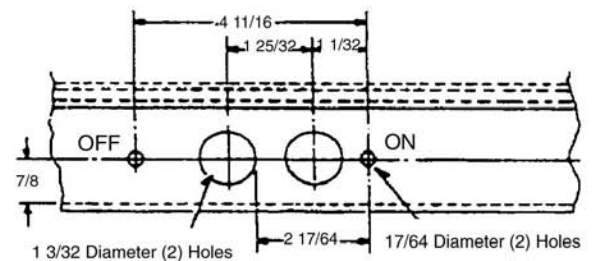

For Alternate Handle Flange

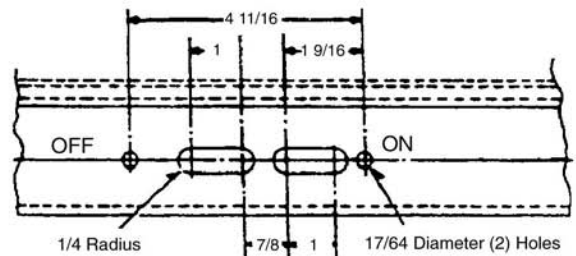

Figure 1-3 Flange Drilling Plan For Handle and Interlock Blade Mounting Dimensions

Cutler-Hammer

Pittsburgh, PA 15220

Effective 2/01 (ISI)
Style 6648C76H04
Printed in U.S.A.

