

Tracer Summit™ BMTX

Retrofit into BMTW/BMTS BCU

Order Numbers: 4950 0531 (Without Modem), 4950 0535 (With Modem)

3270 3421

SAFETY WARNING

Only qualified personnel should install and service the equipment. The installation, starting up, and servicing of heating, ventilating, and air-conditioning equipment can be hazardous and requires specific knowledge and training. Improperly installed, adjusted or altered equipment by an unqualified person could result in death or serious injury. When working on the equipment, observe all precautions in the literature and on the tags, stickers, and labels that are attached to the equipment.

1 Warnings, Cautions, and Notices

Read this manual thoroughly before operating or servicing this unit. Safety advisories appear throughout this manual as required. Your personal safety and the proper operation of this machine depend upon the strict observance of these precautions.

The three types of advisories are defined as follows:

- WARNING** Indicates a potentially hazardous situation which, if not avoided, could result in death or serious injury.
- CAUTION** Indicates a potentially hazardous situation which, if not avoided, could result in minor or moderate injury. It could also be used to alert against unsafe practices.
- NOTICE** Indicates a situation that could result in equipment or property-damage only accidents.

Important Environmental Concerns

Scientific research has shown that certain man-made chemicals can affect the earth's naturally occurring stratospheric ozone layer when released to the atmosphere. In particular, several of the identified chemicals that may affect the ozone layer are refrigerants that contain Chlorine, Fluorine and Carbon (CFCs) and those containing Hydrogen, Chlorine, Fluorine and Carbon (HCFCs). Not all refrigerants containing these compounds have the same potential impact to the environment. Trane advocates the responsible handling of all refrigerants-including industry replacements for CFCs such as HCFCs and HFCs.

Important Responsible Refrigerant Practices

Trane believes that responsible refrigerant practices are important to the environment, our customers, and the air conditioning industry. All technicians who handle refrigerants must be certified according to local rules. For the USA, the Federal Clean Air Act (Section 608) sets forth the requirements for handling, reclaiming, recovering and recycling of certain refrigerants and the equipment that is used in these service procedures. In addition, some states or municipalities may have additional requirements that must also be adhered to for responsible management of refrigerants. Know the applicable laws and follow them.

2

WARNING

Proper Field Wiring and Grounding Required!
Failure to follow code could result in death or serious injury. All field wiring MUST be performed by qualified personnel. Improperly installed and grounded field wiring poses FIRE and ELECTROCUTION hazards. To avoid these hazards, you MUST follow requirements for field wiring installation and grounding as described in NEC and your local/state/national electrical codes.

WARNING

Personal Protective Equipment (PPE) Required!
Failure to wear proper PPE for the job being undertaken could result in death or serious injury. Technicians, in order to protect themselves from potential electrical, mechanical, and chemical hazards, MUST follow precautions in this manual and on the tags, stickers, and labels, as well as the instructions below:

- Before installing/servicing this unit, technicians MUST put on all PPE required for the work being undertaken (Examples; cut resistant gloves/sleeves, butyl gloves, safety glasses, hard hat/bump cap, fall protection, electrical PPE and arc flash clothing). ALWAYS refer to appropriate Safety Data Sheets (SDS) and OSHA guidelines for proper PPE.
- When working with or around hazardous chemicals, ALWAYS refer to the appropriate SDS and OSHA/GHS (Global Harmonized System of Classification and Labeling of Chemicals) guidelines for information on allowable personal exposure levels, proper respiratory protection and handling instructions.
- If there is a risk of energized electrical contact, arc, or flash, technicians MUST put on all PPE in accordance with OSHA, NFPA 70E, or other country-specific requirements for arc flash protection, PRIOR to servicing the unit. NEVER PERFORM ANY SWITCHING, DISCONNECTING, OR VOLTAGE TESTING WITHOUT PROPER ELECTRICAL PPE AND ARC FLASH CLOTHING. ENSURE ELECTRICAL METERS AND EQUIPMENT ARE PROPERLY RATED FOR INTENDED VOLTAGE.

3

WARNING

Follow EHS Policies!
Failure to follow instructions below could result in death or serious injury.

- All Trane personnel must follow the company's Environmental, Health and Safety (EHS) policies when performing work such as hot work, electrical, fall protection, lockout/tagout, refrigerant handling, etc. Where local regulations are more stringent than these policies, those regulations supersede these policies.
- Non-Trane personnel should always follow local regulations.

Copyright

This document and the information in it are the property of Trane, and may not be used or reproduced in whole or in part without written permission. Trane reserves the right to revise this publication at any time, and to make changes to its content without obligation to notify any person of such revision or change.

Trademarks

All trademarks referenced in this document are the trademarks of their respective owners.

4 Retrofit Kit Contents and Software Requirements

The Tracer Summit™ BMTX retrofit kit includes a frame mount, adapter plate, power cable adapter, and a model number label. Two ordering numbers are covered by this document: 4950 0531 without a modem, and 4950 0535 with a modem. The installation steps for both are the same.

Note: This BMTX board requires Tracer Summit v17 software (17.077 BCU image or higher). This board will not function properly with lower BCU images.

Note: All other BMTX BCUs that are connected to the site must be upgraded to the new BCU image at the same time this board is installed. The new BCU images are available to download from the proprietary Trane intranet software downloads web site. Failure to follow this instruction will result in the BCU board not working.

Note: The figures used in this document show the BMTX with modem option.

The following instructions assume that proper retrofit project management, retrofit planning, updated as-built drawings, and site backups have been completed prior to the retrofit.

After the BMTX is installed, use the migration utility to convert the Tracer Summit™ database to use the BMTX. The online help for the migration utility includes step-by-step instructions for converting the database. The migration utility can be found in the Tracer Summit™ Advanced Program group.

Removing the Building Control Unit (BCU) Electronics Assembly

1. Remove the cover from the BCU enclosure.
2. Turn the BCU power switch S1 to OFF (refer to Figure 1, panel 2).
3. Disconnect the BCU power cable (labeled TB1 in the BMTW or P1 in the BMTS) from the BCU main logic board. Unplug the TB2 connector (BMTW) or the TB1 connector (BMTS) from the BCU main logic board (this connector joins the UCM communications wires to the links on the BCU).
4. On the BMTS only, unplug the P2 connector from the BCU main logic board (this connector powers the status lights on the BMTS).

5

5. Tag and disconnect any cables from the cards in the BCU option cards slots (for example, Ethernet, ARCNET, hub, modem, or EIA-232 cards).
6. Grasp the BCU main board mounting plate and pull to remove the assembly.

Note: If an optional input/output board is present, disconnect any wires attached between it and the termination board before removing the assembly.

Figure 1. BCU main logic board (BMTW shown)

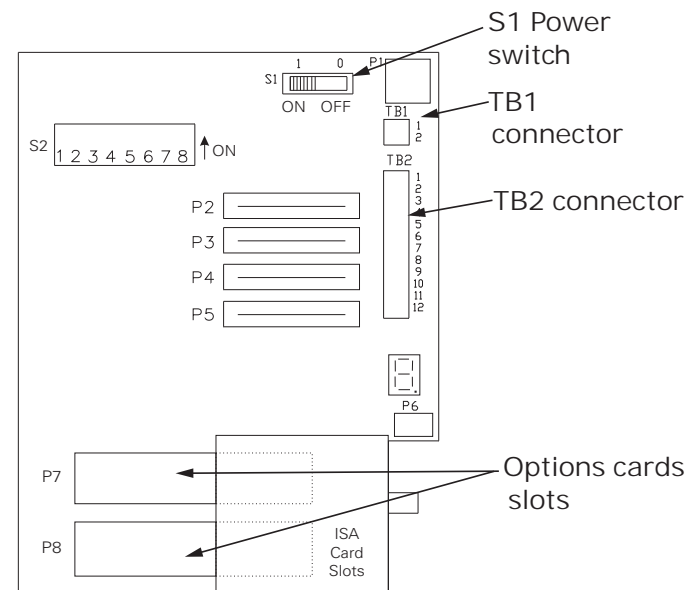

6 Installing the Adapter Plate and Power Cable Adapter

1. Orient the adapter plate as shown in Figure 2, and snap into place on the BCU enclosure.
2. Connect the power adapter cable to the BCU power cable on the BCU enclosure. For the BMTW BCU, connect P2 to the BCU power cable (refer to Figure 3). For the BMTS, connect P1 to the BCU power cable adapter.
3. Route the connected power cable adapter as shown in Figure 4 to accommodate the BMTX frame mount.

7

Figure 2. Installing the adapter plate

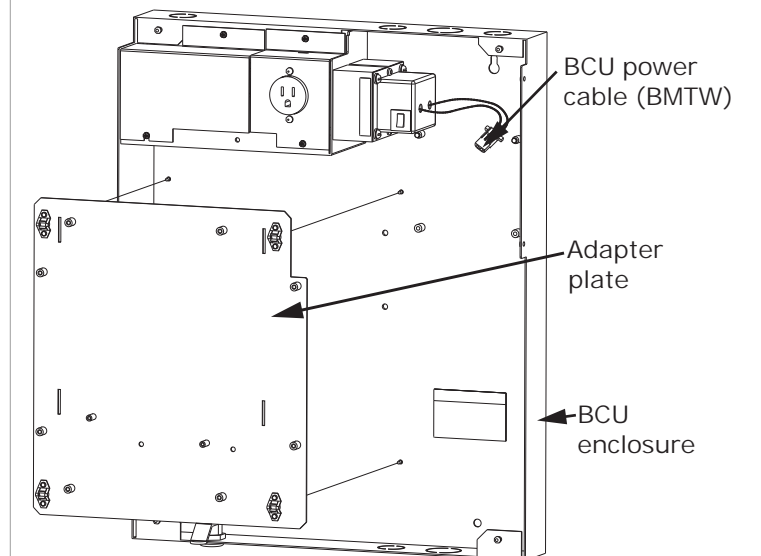

8

Figure 3. BMTW/BMTS power cable adapter

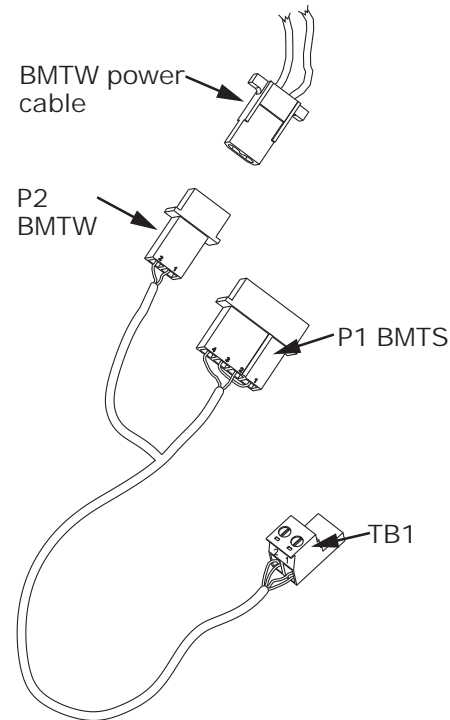

9

Installing the BMTX Frame Mount

1. Mount the BMTX frame mount to the adapter plate as shown in Figure 4 using the screws supplied.

Note: The BMTX frame mount will be mounted upside down compared to an actual BMTX enclosure. This helps to position the termination board on the right side for wiring.

2. Unsnap and fold open the BMTX frame mount to access the grounding screw located just below the 60-pin ribbon cable (refer to Figure 5, panel 7). Securely tighten the grounding screw.

3. Disconnect one comm link pair of wires at a time from TB2 (BMTW) or TB1 (BMTS) from the connector that was previously removed during the retrofit. Reconnect to the appropriate BMTX comm link terminals.

4. Connect the cables that were removed earlier from the BCU option cards slots to the appropriate connections on the BMTX main logic board.

5. Connect the power cable adapter to the TB1 on the BMTX termination board (refer to Figure 6, panel 8). This will cause the BMTX to turn on if the power is already connected. If not, connect the power at this time.

6. Observe the BCU seven-segment display on the logic board. It should count down from "8" and show a -P.

Note: This will be displayed upside down.

10

Figure 4. Installing the BMTX frame mount

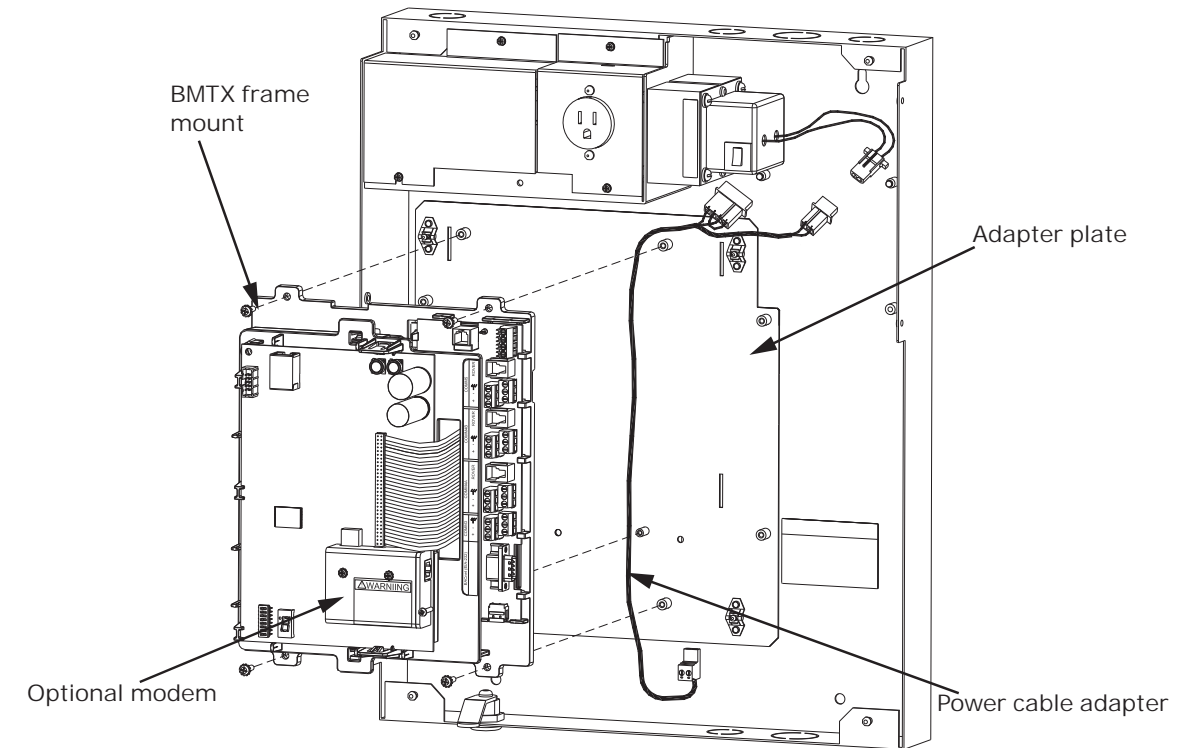

11

Figure 5. Accessing the grounding screw

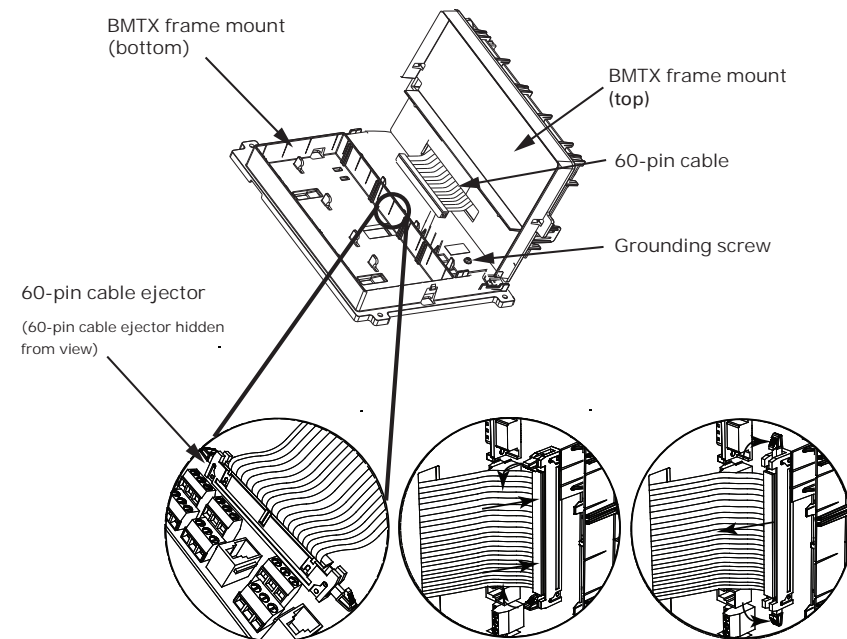

Important: Ensure that the slot keys are aligned when connecting the 60-pin cable to the 60-pin cable ejector as shown in the left inset above. When reconnecting press down firmly on the 60-pin cable until the 60-pin cable ejector tabs collapse and snap over the ends of the cable. When disconnecting, the 60-pin cable ejector is designed to eject the 60-pin cable.

12

Applying the Model Number Label

1. Apply the model number label over the existing label on the Bridge if present. If the Bridge model label is not present, apply the label to the right of the BMTX adapter plate shown in below figure.

2. Replace the Bridge enclosure cover. The BMTX is now ready to be programmed for the site

Figure 6. Completing the BMTX retrofit installation (power connection is for the BMTW, not the BMTS)

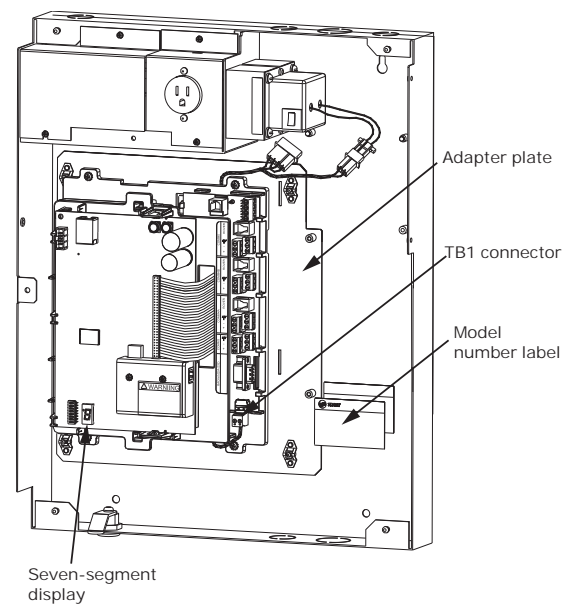

Trane - by Trane Technologies (NYSE: TT), a global climate innovator - creates comfortable, energy efficient indoor environments for commercial and residential applications. For more information, please visit trane.com or tranetechnologies.com.

Trane has a policy of continuous product and product data improvement and reserves the right to change design and specifications without notice. We are committed to using environmentally conscious print practices.

BAS-SVN228F-EN 31 Aug 2021
Supersedes 3270 3421E (Nov 2013)

©2021 Trane