

Installation Instructions

Vibration Mounting for Split Systems

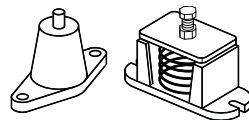

Model Number: BAYISLT004, 005, 009, 010, 012, 013, 014, 015, 016, 019, 021, 023, 024, 025, TTA, TWA and TWE units 028, 029, 030, 031, 032

Used With:

SAFETY WARNING
Only qualified personnel should install and service the equipment. The installation, starting up, and servicing of heating, ventilating, and air-conditioning equipment can be hazardous and requires specific knowledge and training. Improperly installed, adjusted or altered equipment by an unqualified person could result in death or serious injury. When working on the equipment, observe all precautions in the literature and on the tags, stickers, and labels that are attached to the equipment.

April 2020

ACC-SVN92H-EN

© 2020

1 Warnings, Cautions, and Notices

Read this manual thoroughly before operating or servicing this unit. Safety advisories appear throughout this manual as required. Your personal safety and the proper operation of this machine depend upon the strict observance of these precautions.

The three types of advisories are defined as follows:

- WARNING** Indicates a potentially hazardous situation which, if not avoided, could result in death or serious injury.
- CAUTION** Indicates a potentially hazardous situation which, if not avoided, could result in minor or moderate injury. It could also be used to alert against unsafe equipment or property-damage only accidents.
- NOTICE** Indicates a situation that could result in equipment or property-damage only accidents.

Important Environmental Concerns

Scientific research has shown that certain man-made chemicals can affect the earth's naturally occurring stratospheric ozone layer when released to the atmosphere. In particular, several of the identified chemicals that may affect the ozone layer are refrigerants that contain Chlorine, Fluorine and Carbon (CFCs) and those containing Hydrogen, Chlorine, Fluorine and Carbon (HCFCs). Not all refrigerants containing these compounds have the same potential impact to the environment. Trane advocates the responsible handling of all refrigerants-including industry replacements for CFCs such as HCFCs and HFCs.

Important Responsible Refrigerant Practices

Trane believes that responsible refrigerant practices are important to the environment, our customers, and the air conditioning industry. All technicians who handle refrigerants must be certified according to local rules. For the USA, the Federal Clean Air Act (Section 608) sets forth the requirements for handling, reclaiming, recovering and recycling of certain refrigerants and the equipment that is used in these service procedures. In addition, some states or municipalities may have additional requirements that must also be adhered to for responsible management of refrigerants. Know the applicable laws and follow them.

2 WARNING

Proper Field Wiring and Grounding Required!
Failure to follow code could result in death or serious injury. All field wiring MUST be performed by qualified personnel. Improperly installed and grounded field wiring poses FIRE and ELECTROCUTION hazards. To avoid these hazards, you MUST follow requirements for field wiring installation and grounding as described in NEC and your local/state electrical codes.

WARNING

Personal Protective Equipment Required!
Installing/servicing this unit could result in exposure to electrical, mechanical and chemical hazards. Before installing/servicing this unit, technicians MUST put on all Personal Protective Equipment (PPE) recommended for the work being undertaken. ALWAYS refer to appropriate SDS sheets and OSHA guidelines for proper PPE. When working with or around hazardous chemicals, ALWAYS refer to the appropriate SDS sheets and OSHA guidelines for information on allowable personal exposure levels, proper respiratory protection and handling recommendations. If there is a risk of arc or flash, technicians MUST put on all necessary Personal Protective Equipment (PPE) in accordance with NFPA70E for arc/flash protection PRIOR to servicing the unit. Failure to follow recommendations could result in death or serious injury.

WARNING

Follow EHS Policies!
Failure to follow instructions below could result in death or serious injury.

- All Trane personnel must follow the company's Environmental, Health and Safety (EHS) policies when performing work such as hot work, electrical, fall protection, lockout/tagout, refrigerant handling, etc. Where local regulations are more stringent than these policies, those regulations supersede these policies.
- Non-Trane personnel should always follow local regulations.

3 Heavy Object!

Failure to follow these instructions could result in death, serious injury, and property damage.
Make certain that the lifting methods used to lift the duct furnace are capable of supporting the weight of the heater during installation. Ensure that all hardware used in the suspension of each duct furnace is more than adequate for the job. Make certain that the structure to which the duct furnace is to be mounted is capable of safely supporting its weight. Under no circumstances must the gas lines, venting system, or the electrical conduit be used to support the duct furnace. Do not allow objects (i.e. ladder) or people to lean against the gas lines, venting system, or electrical conduit for support.

General

The isolators referred to in this installer's guide can be used with split system air handlers in the vertical position (with accessory base) or in the horizontal position (suspended) and with split system condensers, heat pumps.

These isolators shall be used on units with or without electric heaters and with or without discharge plenums. Isolators that are used with steam or hot water coils (BAYWATR) require the BAYWATR kits to be self-supported in the horizontal application (independent of the unit supports).

Refer to Table 1 to determine which isolators are to be installed in a particular unit application. Refer to the appropriate installation instruction for the particular isolators being installed. Isolators may be secured to the floor or other surface by means of the slots (or holes) in the isolators.

Note: The isolators referred to in this installation guide are not to be used as seismic restraints. In areas where seismic restraints are required, consult local codes for proper devices and installation procedures.

4 Inspection

Check the package and contents for damage. Report any damage immediately to the transportation company, and make any appropriate claims.

Installation

Floor Mounted - Rubber (nonadjustable)

BAYISLT004, BAYISLT005, BAYISLT009, BAYISLT010 (Condensers and Heat Pumps)

1. Place a stiffening bracket beneath the base rail at the unit's four corners as shown in Figure 7.
2. Remove the attaching bolt from the isolators.
3. Place the isolators under the unit with the holes in the isolators aligned with the holes in the stiffening bracket and the unit base rails.
4. Insert the isolator bolts through the ends of the unit base rails and into the isolators. Tighten the isolator bolts.

(Air Handlers with accessory base)

Note: Neoprene (rubber) vibration isolators are NOT recommended for air handlers with blowers operating at less than 600 rpm.

Note: For ease of installation, it is recommended that the isolators be attached to the accessory base before the air handler is installed on the base.

1. Remove the attaching bolt from the isolators.
2. Place the isolators under the accessory base with the holes in the isolators aligned with the holes in the base.
3. Insert the isolator bolts through the holes in the accessory base and into the isolators. Tighten the isolator bolts.

5 Figure 1. Floor Mounted - Rubber

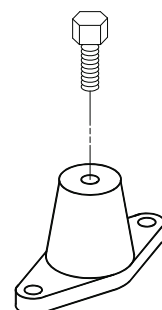

Suspended - Rubber (nonadjustable) and Spring (nonadjustable)

BAYISLT012, BAYISLT013, BAYISLT014, BAYISLT015, BAYISLT016 (Rubber), BAYISLT028, BAYISLT029, BAYISLT030, BAYISLT031 (Spring) (Air Handlers only, horizontal position)

Important: A 3/8" threaded support rod is required by the horizontal spring or rubber isolator kits. Refer to "Notes" under Table 1 for proper isolator positioning.

1. Remove the four 7/8" diameter plugs located in the top four corners of the air handler.
2. Remove the access panels directly adjacent to the four plugs.
3. Insert the proper supporting rod (field supplied) through each of the four plugs and secure from the underside with a large washer and securing nut.
4. Thread the other ends of the supporting rods through the bottom of the isolators, and secure with washer and nut.
5. With a second set of four supporting rods (field supplied), attached to the top of the isolators, secure the unit to a suitable suspending structure.

6 Figure 2. Suspended - Rubber Figure 3. Suspended - Spring

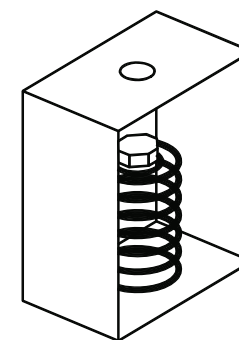
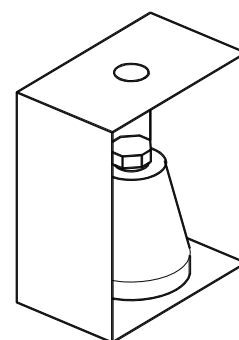

Floor Mounted - Spring (adjustable)

BAYISLT023, BAYISLT024, BAYISLT025 (Condensers and Heat Pumps)

1. Remove the attaching/adjusting bolt from the isolators.
2. Place a stiffening bracket on each isolator at the unit's four corners as shown in Figure 8.
3. Position the isolators under the unit with the holes in isolators aligned with the holes in the stiffening bracket and the unit base rails.
4. Turn the locking nut on the adjusting bolt until it contacts the bolt head. Insert the adjusting bolts through the ends of the unit base rails and into the isolators. Tighten the adjusting bolt until the unit is level. See adjusting note on page 3.
5. Tighten the locking nut against the unit base.

7 Figure 4. Floor Mounted - Spring

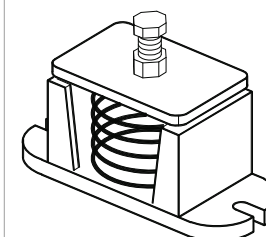

Floor Mounted - Spring (adjustable)

BAYISLT019, BAYISLT021, BAYISLT032

(Air Handlers with accessory base)

1. Place the isolators under the accessory base with the isolator pin protruding through the holes in the base.
2. Place the air handler on the accessory base in accordance with the accessory base installer's guide.
3. Insert a wrench through the side of each isolator and turn the adjusting bolt until the unit is level. See adjusting note.

Note: Adjusting Note: The unit should be leveled after it has been fully charged and all accessories have been installed. The clearance between the upper and lower housings of the isolators should range from 1/4 inch to 1/2 inch when the unit is level.

Figure 5. Floor mounted - spring

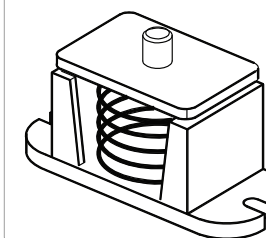

8

Figure 6. Isolator clearance requirements

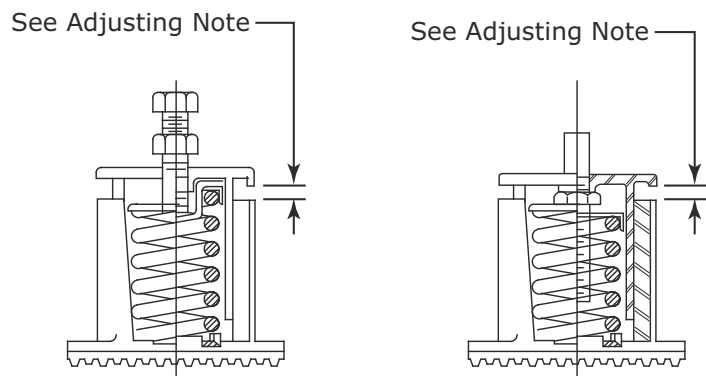

9

Figure 7. Rubber isolator installation

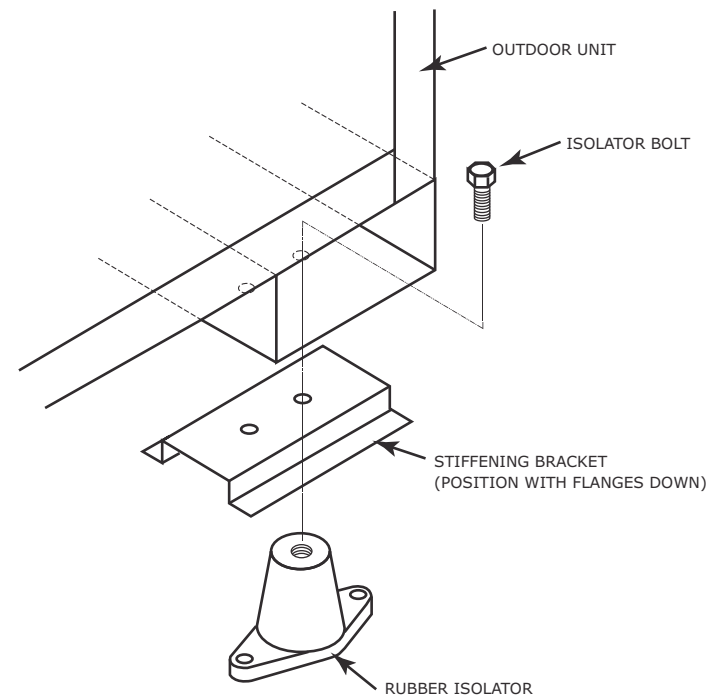

NOTE:
POSITION STIFFENING ANGLE UNDER UNIT BASE RAIL AND ALIGN HOLE SO THAT THE ANGLE DOESN'T PROTRUDE BEYOND THE OUTER EDGE OF THE UNIT.

10

Figure 8. Spring isolator installation

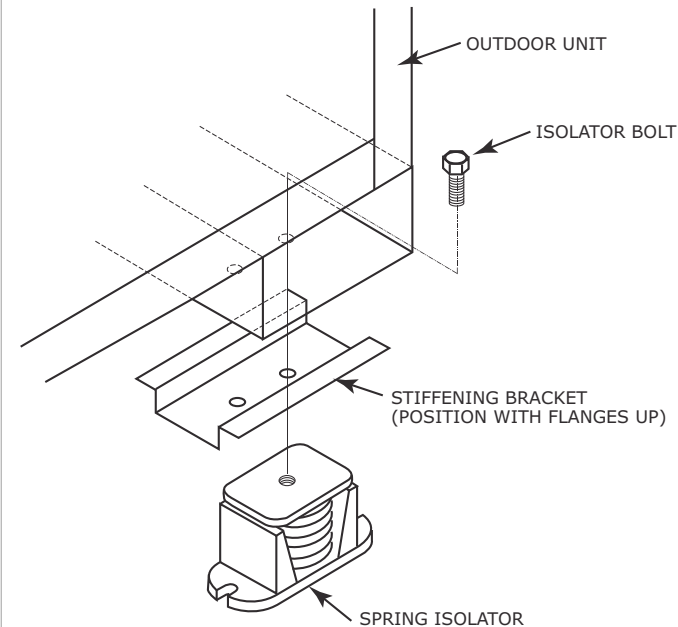

NOTE:
POSITION STIFFENING ANGLE UNDER UNIT BASE RAIL AND ALIGN HOLE SO THAT THE ANGLE DOESN'T PROTRUDE BEYOND THE OUTER EDGE OF THE UNIT.

Table 1. Isolator application table - TWE

Model No.	TWE 051/060	TWE 072	TWE 076/090	TWE 101/120	TWE 126/150	TWE 156/180	TWE 201/240	TWE 251/300
BAYISLT004	X	X	X	X				

11

Table 1. Isolator application table - TWE (continued)

Model No.	TWE 051/060	TWE 072	TWE 076/090	TWE 101/120	TWE 126/150	TWE 156/180	TWE 201/240	TWE 251/300
BAYISLT005					X	X		
BAYISLT009							X	X
BAYISLT010					X	X		
BAYISLT012 ^(a)					X	X		
BAYISLT013 ^(b)	X							
BAYISLT014		X	X					
BAYISLT015 ^(c)								
BAYISLT016 ^(d)								
BAYISLT019	X	X	X	X				
BAYISLT021					X	X		
BAYISLT023								
BAYISLT024								
BAYISLT025								
BAYISLT028	X							
BAYISLT029		X	X	X				
BAYISLT030					X	X		
BAYISLT031 ^(e)							X	X
BAYISLT032 ^(f)							X	X

Table 2. Isolator application table - TWA/TTA

Model No.	TWA 060/072	TWA 076/090	TWA 101/120	TWA 156/180	TWA 201/240	TTA 060/072	TTA 076/090	TTA 101/120
BAYISLT004						X	X	
BAYISLT005	X	X	X					X
BAYISLT009				X				
BAYISLT010					X			
BAYISLT012 ^(a)								
BAYISLT013 ^(b)								
BAYISLT014								
BAYISLT015 ^(c)								
BAYISLT016 ^(d)								

12

Table 2. Isolator application table - TWA/TTA

Model No.	TWA 060/072	TWA 076/090	TWA 101/120	TWA 156/180	TWA 201/240	TTA 060/072	TTA 076/090	TTA 101/120
BAYISLT019								
BAYISLT021								
BAYISLT023	X	X	X			X	X	X
BAYISLT024				X				
BAYISLT025					X			
BAYISLT028								
BAYISLT029								
BAYISLT030								
BAYISLT031 ^(e)								
BAYISLT032 ^(f)								

Table 3. Isolator application table - TTA

Model No.	TTA 126/150	TTA 156/180	TTA 201/240	TTA 251/300
BAYISLT004				
BAYISLT005				
BAYISLT009	X	X		
BAYISLT010			X	X
BAYISLT012 ^(a)				
BAYISLT013 ^(b)				
BAYISLT014				
BAYISLT015 ^(c)				
BAYISLT016 ^(d)				
BAYISLT019				
BAYISLT021				
BAYISLT023				
BAYISLT024	X	X		
BAYISLT025			X	X
BAYISLT028				
BAYISLT029				
BAYISLT030				
BAYISLT031 ^(e)				
BAYISLT032 ^(f)				

13

Note: For units with BAYWATR kits installed, use Table 4 for kit application table. See Figure 9 for corner designations.

- (a) Kit BAYISLT012 contains 5 isolators, (4 red and 1 green). TWE156/180 units without electric heat or discharge plenums use the 4 red isolators. TWE156/180 units with electric heat or discharge plenums require red isolators at locations "A", "C", and "D", and a green isolator at location "B".
- (b) Kit BAYISLT013 contains 6 isolators, (3 red and 3 green). TWE051/060 units without electric heat or discharge plenums require red isolators at locations "B" and "D" and green isolators at locations "A" and "C". TWE051/060 units with electric heat or discharge plenums require a red isolator at location "D" and green isolators at locations "A", "B" and "C".
- (c) Kit BAYISLT015 contains 5 isolators, (3 black and 2 green). TWE101/120**A units without electric heat or discharge plenums require black isolators at locations "B" and "D", and green isolators at locations "A" and "C".
- (d) Kit BAYISLT016 contains 4 isolators, (2 red and 2 green). TWE201/240/251/300 units require green isolators at locations "A" and "D", and red isolators at locations "B" and "C".
- (e) Kit BAYISLT031 contains 6 isolators, (4 black and 2 yellow). TWE201/240/251/300 units without electric heat or discharge plenums use the 4 black isolators. TWE201/240/251/300 units with electric heat or discharge plenums require black isolators at locations "C" and "D", and yellow isolators at locations "A" and "B".
- (f) Kit BAYISLT032 contains 4 isolators (2 Black, 2 Yellow). TWE201/240/251/300 units without electric heat or discharge plenums use 2 Black at locations "2" and "3" and 2 yellow isolators at locations "1" and "4".

Table 4. Isolator application table with BAYWATR accessory

Model No.	TWE 051/060	TWE 072	TWE 076/090	TWE 101/120	TWE 126/150	TWE 156/180	TWE 201/240/251/300
BAYISLT004	X	X	X				
BAYISLT005							
BAYISLT009				X	X	X	
BAYISLT010							X
BAYISLT012		X	X	X			
BAYISLT013	X						
BAYISLT014							
BAYISLT015							
BAYISLT016					X	X	X
BAYISLT019	X	X	X				
BAYISLT021				X	X	X	

14

Table 4. Isolator application table with BAYWATR accessory

Model No.	TWE 051/060	TWE 072	TWE 076/090	TWE 101/120	TWE 126/150	TWE 156/180	TWE 201/240/251/300
BAYISLT023							
BAYISLT024							
BAYISLT025							
BAYISLT028							
BAYISLT029	X	X	X				
BAYISLT030				X			
BAYISLT031					X	X	X
BAYISLT032							X

Figure 9. Corner designations

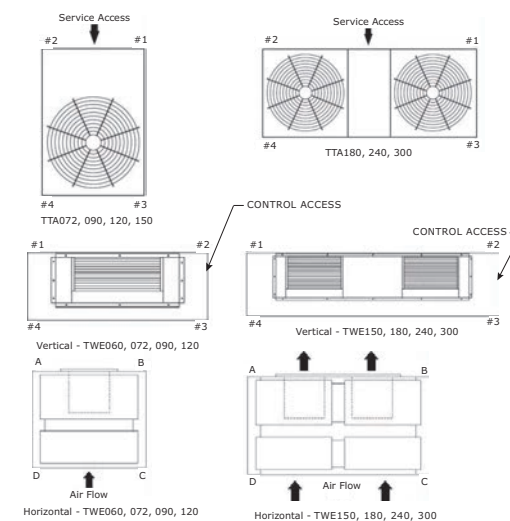

Trane and American Standard create comfortable, energy efficient indoor environments for commercial and residential applications. For more information, please visit trane.com or americanstandardair.com.

Trane and American Standard have a policy of continuous product and product data improvement and reserve the right to change design and specifications without notice. We are committed to using environmentally conscious print practices.