

Installation Instructions

Comparative Enthalpy Kit Used with 3 to 10 Tons Packaged Units with ReliaTel™ Controls

Model Number: Used With:
BAYENTH006B* All Precedent™ units equipped with an economizer

SAFETY WARNING

Only qualified personnel should install and service the equipment. The installation, starting up, and servicing of heating, ventilating, and air-conditioning equipment can be hazardous and requires specific knowledge and training. Improperly installed, adjusted or altered equipment by an unqualified person could result in death or serious injury. When working on the equipment, observe all precautions in the literature and on the tags, stickers, and labels that are attached to the equipment.

October 2020

ACC-SVN41N-EN

© 2020

1

Warnings, Cautions, and Notices

Read this manual thoroughly before operating or servicing this unit. Safety advisories appear throughout this manual as required. Your personal safety and the proper operation of this machine depend upon the strict observance of these precautions.

The three types of advisories are defined as follows:

WARNING

Indicates a potentially hazardous situation which, if not avoided, could result in death or serious injury.

CAUTION

Indicates a potentially hazardous situation which, if not avoided, could result in minor or moderate injury. It could also be used to alert

NOTICE

Indicates a situation that could result in equipment or property-damage only accidents.

Important Environmental Concerns

Scientific research has shown that certain man-made chemicals can affect the earth's naturally occurring stratospheric ozone layer when released to the atmosphere. In particular, several of the identified chemicals that may affect the ozone layer are refrigerants that contain Chlorine, Fluorine and Carbon (CFCs) and those containing Hydrogen, Chlorine, Fluorine and Carbon (HCFCs). Not all refrigerants containing these compounds have the same potential impact to the environment. Trane advocates the responsible handling of all refrigerants-including industry replacements for CFCs such as HCFCs and HFCs.

Important Responsible Refrigerant Practices

Trane believes that responsible refrigerant practices are important to the environment, our customers, and the air conditioning industry. All technicians who handle refrigerants must be certified according to local rules. For the USA, the Federal Clean Air Act (Section 608) sets forth the requirements for handling, reclaiming, recovering and recycling of certain refrigerants and the equipment that is used in these service procedures. In addition, some states or municipalities may have additional requirements that must also be adhered to for responsible management of refrigerants. Know the applicable laws and follow them.

2

WARNING

Proper Field Wiring and Grounding Required!

Failure to follow code could result in death or serious injury. All field wiring MUST be performed by qualified personnel. Improperly installed and grounded field wiring poses FIRE and ELECTROCUTION hazards. To avoid these hazards, you MUST follow requirements for field wiring installation and grounding as described in NEC and your local/state electrical codes.

WARNING

Personal Protective Equipment Required!

Installing/servicing this unit could result in exposure to electrical, mechanical and chemical hazards. Before installing/servicing this unit, technicians MUST put on all Personal Protective Equipment (PPE) recommended for the work being undertaken. ALWAYS refer to appropriate SDS sheets and OSHA guidelines for proper PPE. When working with or around hazardous chemicals, ALWAYS refer to the appropriate SDS sheets and OSHA guidelines for information on allowable personal exposure levels, proper respiratory protection and handling recommendations. If there is a risk of arc or flash, technicians MUST put on all necessary Personal Protective Equipment (PPE) in accordance with NFPA70E for arc/flash protection PRIOR to servicing the unit. Failure to follow recommendations could result in death or serious injury.

General

Inspection

1. Unpack all components of the BAYENTH006* kit.
2. Check carefully for any shipping damage. If any damage is found it must be reported immediately and a claim made against the transportation company.
3. If Enhanced Econ Logic Module is not installed in the unit, it has to be purchased.

3

Parts List

- 2 - Sensor, Humidity
- 1 - Harness, Econ - OD Humidity Sensor
- 1 - Harness, Econ - RA Sensor
- 1 - Thermistor, -40 to 65 °C
- 4 - Tie, Wire
- 1 - Grommet
- 4 - Screw, Mounting - #6-32 UNC X 3/4 inch (22.2mm)

Installation

WARNING

Hazardous Voltage w/Capacitors!

Failure to disconnect power and discharge capacitors before servicing could result in death or serious injury. Disconnect all electric power, including remote disconnects and discharge all motor start/run capacitors before servicing. Follow proper lockout/tagout procedures to ensure the power cannot be inadvertently energized. Verify with an appropriate voltmeter that all capacitors have discharged.

For additional information regarding the safe discharge of capacitors, see PROD-SVB06A-EN.

Outdoor Humidity Sensor Installation

1. Remove filter access panel.
2. Remove one screw from the mist eliminator retaining angle and loosen the other screw.
3. Remove the mist eliminator.
4. Connect wire 156A (RD) to the positive terminal on the humidity sensor. Connect wire 157A (VIO) to the remaining terminal on the humidity sensor.
5. Position sensor and secure with two screws as shown in [Figure 1](#).

4

Figure 1. Route sensor wires

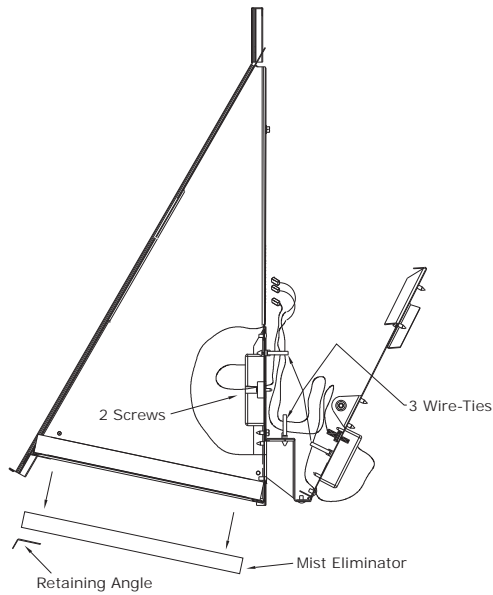

6. Route sensor wires through star bushing as shown in Figure 1.
7. Attach P12 plug to OAH/OAE pin on ECA as shown in Figure 2.

6

5. Install Return Air Temperature Sensor with rubber grommet. Refer to Figure 2.
 6. Attach P10 plug to RAT pin on ECA as shown in Figure 2.
 7. Secure wiring harnesses with 3 wire ties as shown in Figure 1.
- Note:** Allow enough slack in wire harness to permit the return air damper blade to close fully without pulling or binding the harness.
8. Replace the filter access panel.

5

Figure 2. Route sensor wires

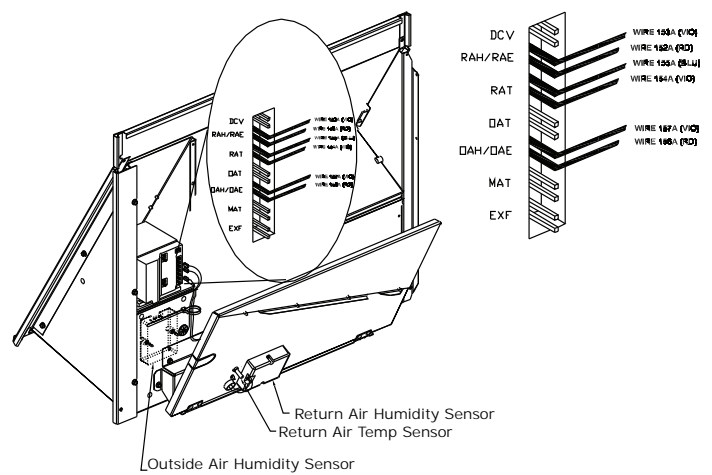

8. Secure wires with wire tie as shown in Figure 1.
9. Replace mist eliminator.
10. Replace mist eliminator retaining angle by sliding one slotted end of the retaining angle onto the loosened screw and replace the screw on the other end of the retaining angle. Tighten both screws.

Return Air Humidity Sensor and Return Air Temperature Sensor Installation

1. Connect the Red wire to the positive terminal on the humidity sensor. Connect the other wire to the remaining terminal on the humidity sensor.
2. Install Return Air Humidity Sensor and secure with 2 screws. Refer to Figure 2.
3. Route Return Air Humidity Sensor through grommet.
4. Attach P9 plug to RAH/RAE pin on ECA as shown in Figure 2.

Trane and American Standard create comfortable, energy efficient indoor environments for commercial and residential applications. For more information, please visit trane.com or americanstandardair.com.

Trane and American Standard have a policy of continuous product and product data improvement and reserve the right to change design and specifications without notice. We are committed to using environmentally conscious print practices.