

Installation Guide

Transformer

Odyssey Air Handlers

6–12.5 Tons

BAYTFMR011	TWE072*3B*****0, TWE090*3A*****0/B*****0, TWE120*3A*****0/B*****0, TWE120*3B*****A, TWE150*3B*****A
BAYTFMR012	TWE072*3B*****0, TWE090*3A*****0/B*****0, TWE120*3A*****0/B*****0, TWE120*4B*****A, TWE150*4B*****A, TWE072*WB*****0, TWE090*WA*****0/B*****0, TWE120*WA*****0/B*****0
BAYTFMR013	TWE072*DB*****0, TWE076*DA*****0/B*****0, TWE101*DA*****0/B*****0

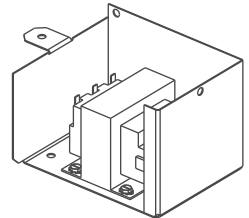

▲ SAFETY WARNING

Only qualified personnel should install and service the equipment. The installation, starting up, and servicing of heating, ventilating, and air-conditioning equipment can be hazardous and requires specific knowledge and training. Improperly installed, adjusted or altered equipment by an unqualified person could result in death or serious injury. When working on the equipment, observe all precautions in the literature and on the tags, stickers, and labels that are attached to the equipment.

Introduction

Read this manual thoroughly before operating or servicing this unit.

Warnings, Cautions, and Notices

Safety advisories appear throughout this manual as required. Your personal safety and the proper operation of this machine depend upon the strict observance of these precautions.

The three types of advisories are defined as follows:



Indicates a potentially hazardous situation which, if not avoided, could result in death or serious injury.



Indicates a potentially hazardous situation which, if not avoided, could result in minor or moderate injury. It could also be used to alert against unsafe practices.

NOTICE

Indicates a situation that could result in equipment or property-damage only accidents.

Important Environmental Concerns

Scientific research has shown that certain man-made chemicals can affect the earth's naturally occurring stratospheric ozone layer when released to the atmosphere. In particular, several of the identified chemicals that may affect the ozone layer are refrigerants that contain Chlorine, Fluorine and Carbon (CFCs) and those containing Hydrogen, Chlorine, Fluorine and Carbon (HCFCs). Not all refrigerants containing these compounds have the same potential impact to the environment. Trane advocates the responsible handling of all refrigerants-including industry replacements for CFCs and HCFCs such as saturated or unsaturated HFCs and HCFCs.

Important Responsible Refrigerant Practices

Trane believes that responsible refrigerant practices are important to the environment, our customers, and the air conditioning industry. All technicians who handle refrigerants must be certified according to local rules. For the USA, the Federal Clean Air Act (Section 608) sets forth the requirements for handling, reclaiming, recovering and recycling of certain refrigerants and the equipment that is used in these service procedures. In addition, some states or municipalities may have additional requirements that must also be adhered to for responsible management of refrigerants. Know the applicable laws and follow them.

⚠ WARNING

Proper Field Wiring and Grounding Required!

Failure to follow code could result in death or serious injury.

All field wiring **MUST** be performed by qualified personnel. Improperly installed and grounded field wiring poses **FIRE** and **ELECTROCUTION** hazards. To avoid these hazards, you **MUST** follow requirements for field wiring installation and grounding as described in **NEC** and your local/state/national electrical codes.

⚠ WARNING

Personal Protective Equipment (PPE) Required!

Failure to wear proper PPE for the job being undertaken could result in death or serious injury. Technicians, in order to protect themselves from potential electrical, mechanical, and chemical hazards, **MUST** follow precautions in this manual and on the tags, stickers, and labels, as well as the instructions below:

- Before installing/servicing this unit, technicians **MUST** put on all PPE required for the work being undertaken (Examples; cut resistant gloves/sleeves, butyl gloves, safety glasses, hard hat/bump cap, fall protection, electrical PPE and arc flash clothing). **ALWAYS** refer to appropriate Safety Data Sheets (SDS) and OSHA guidelines for proper PPE.
- When working with or around hazardous chemicals, **ALWAYS** refer to the appropriate SDS and OSHA/GHS (Global Harmonized System of Classification and Labelling of Chemicals) guidelines for information on allowable personal exposure levels, proper respiratory protection and handling instructions.
- If there is a risk of energized electrical contact, arc, or flash, technicians **MUST** put on all PPE in accordance with OSHA, NFPA 70E, or other country-specific requirements for arc flash protection, **PRIOR** to servicing the unit. **NEVER PERFORM ANY SWITCHING, DISCONNECTING, OR VOLTAGE TESTING WITHOUT PROPER ELECTRICAL PPE AND ARC FLASH CLOTHING. ENSURE ELECTRICAL METERS AND EQUIPMENT ARE PROPERLY RATED FOR INTENDED VOLTAGE.**

⚠ WARNING**Follow EHS Policies!**

Failure to follow instructions below could result in death or serious injury.

- All Trane personnel must follow the company's Environmental, Health and Safety (EHS) policies when performing work such as hot work, electrical, fall protection, lockout/tagout, refrigerant handling, etc. Where local regulations are more stringent than these policies, those regulations supersede these policies.
- Non-Trane personnel should always follow local regulations.

Copyright

This document and the information in it are the property of Trane, and may not be used or reproduced in whole or in part without written permission. Trane reserves the right to revise this publication at any time, and to make changes to its content without obligation to notify any person of such revision or change.

Trademarks

All trademarks referenced in this document are the trademarks of their respective owners.

Revision History

This version includes updates to the following:

- Running edits
- Model number updates for TWE Air Handlers

Inspection

Remove the contents of the kit from the shipping package and inspect for possible damage. If the accessory has been damaged, it should be reported to and claims made against the transportation company immediately. Any missing parts should be immediately reported to your supplier and replaced with authorized parts only.

General Information

The transformers referred to in this Installation Instructions manual are used with air handlers in conjunction with condensers that were not equipped with factory installed low voltage transformers. Refer to the table below to determine which kit is used with a particular voltage unit.

Table 1. Transformer kits

Transformer	Voltage	Unit(s)
BAYTFMR011	208/230	TWE072*3B*****0, TWE090*3A*****0/B*****0, TWE120*3A*****0/B*****0, TWE120*3B*****A, TWE150*3B*****A
BAYTFMR012	460	TWE072*3B*****0, TWE090*3A*****0/B*****0, TWE120*3A*****0/B*****0, TWE120*4B*****A, TWE150*4B*****A,
BAYTFMR012	575	TWE072*WB*****0, TWE090*WA*****0/B*****0, TWE120*WA*****0/B*****0
BAYTFMR013	380/415	TWE072*DB*****0, TWE076*DA*****0/B*****0, TWE101*DA*****0/B*****0

Parts List

Figure 1. Transformer kit contents

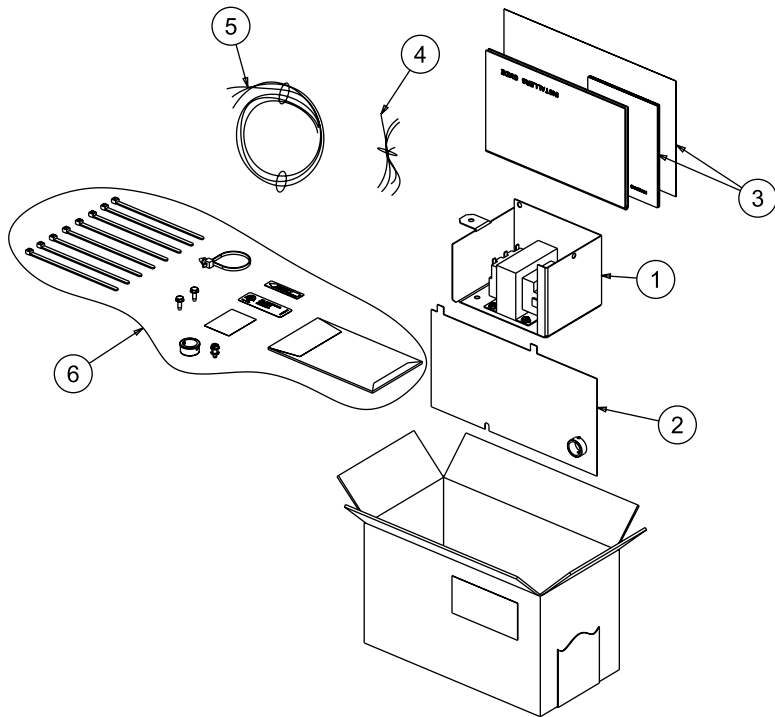

- 1. Transformer w/ Enclosure
- 2. Control Box Access Cover
- 3. (5) Connection Diagrams & (4) Wiring Diagrams
- 4. Wire Harness (Standard Unit)
- 5. Wire Harness (2-Speed Unit)
- 6. Envelope contents:
 - (1) Reset Label
 - (1) Kit Installed Label
 - (1) ETL Label
 - (1) Bushing
 - (1) Green Ground Screw
 - (1) Lock Washer
 - (2) Screws
 - (1) Pop-in Wire Tie
 - (8) Wire Ties

Table of Contents

Installation 6
 Standard Unit Transformer..... 6

2-Speed Unit Transformer..... 7
Wiring Diagrams 9

Installation

Standard Unit Transformer

⚠ WARNING

Hazardous Voltage w/Capacitors!

Failure to disconnect power and discharge capacitors before servicing could result in death or serious injury.

Disconnect all electric power, including remote disconnects and discharge all motor start/run capacitors before servicing. Follow proper lockout/tagout procedures to ensure the power cannot be inadvertently energized. For variable frequency drives or other energy storing components provided by Trane or others, refer to the appropriate manufacturer's literature for allowable waiting periods for discharge of capacitors. Verify with a CAT III or IV voltmeter rated per NFPA 70E that all capacitors have discharged.

For additional information regarding the safe discharge of capacitors, see PROD-SVB06*-EN.

Figure 2. Standard control box transformer installation

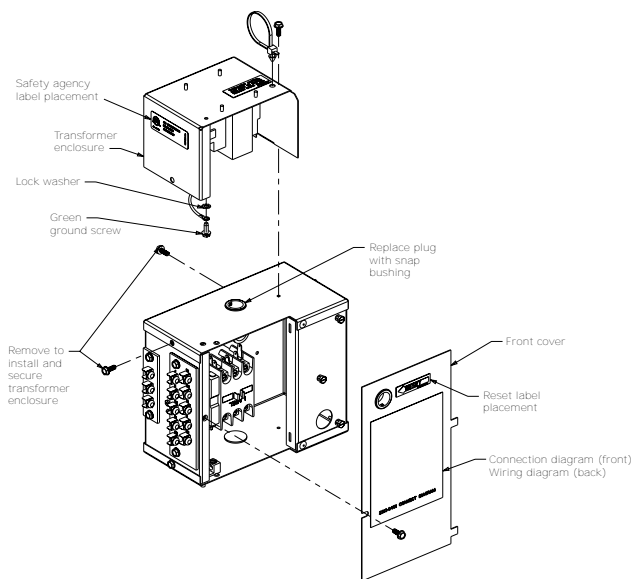

1. Remove the air handler's side panel which conceals the unit control box (the panel above the nameplate).
2. Remove and retain the 2 screws that secure the top cover of the control box (leave the top cover on the control box). See Figure 2, p. 6.
3. Remove the front cover from the control box and discard.
4. Remove the plug in the top cover of the control box, discard, and install the snap bushing that is

supplied with the kit. See Figure 2, p. 6.

5. Connect standard unit transformer wire harness on to transformer per unit diagram. Attach ground wire to transformer enclosure using the green ground screw passing through the wire terminal then the lock washer. See Figure 2, p. 6.
6. Position the transformer kit over the control box top cover with the open side lining up with the opening on the control box. See Figure 2, p. 6.
7. Thread the wires coming from the transformer through the snap bushing that was just installed in the top of the control box.
8. With the transformer kit covering the top cover of the control box, secure it in place with the screws that were retained in step 2 (these two screws will go into the same holes that they came from). See Figure 2, p. 6.
9. Using a third screw supplied with the kit, finish securing the transformer kit to the top of the control box by installing the third screw through the hole in the tab on the transformer kit to the corresponding hole in the top cover of the control box. See Figure 2, p. 6.
10. Apply the safety agency label to the side of the transformer enclosure as shown in Figure 2, p. 6.
11. Apply the Reset label to the front cover with arrow pointing towards the snap bushing as shown in Figure 2, p. 6.

Notes:

- The (BAYTFMR011 and BAYTFMR012) transformers are factory wired for 230V and 460V power respectively. To convert BAYTFMR011 to 208 volt power, disconnect wire 1L (R) from the 230V terminal on the primary side of the transformer and reconnect to the 208V terminal. To convert BAYTFMR012 to 575 volt power, disconnect wire 1L (R) from the 460V terminal on the primary side of the transformer and reconnect to the 575V terminal. See the wiring diagram in .
- Full wiring schematics are available through e-Library. If access is not available, contact your local sales office.

12. Disconnect wire 68T(BL) from the auxiliary contact on the side of the indoor fan contactor in the control box.
13. Connect the piggy back terminal end of wire 68U (BL), coming from the transformer supplied with the kit, to the terminal where wire 68T(BL) was just disconnected from on the auxiliary contact on the side of the indoor fan contactor.
14. Reconnect wire 68T(BL) to the piggy back terminal

on wire 68U(BL) on the auxiliary contact on the side of the indoor fan contactor. (See the wiring diagram in .)

15. Connect wire 59F(R), coming from the transformer supplied with the kit, to terminal "R" on the low voltage terminal board (LTB2) on the side of the control box. (See the wiring diagram in .)
16. Connect wire 1L(R) to the 1/4" quick connect male terminal on the line side of the contactor (the bottom side) following the wiring diagrams in and .
17. Connect wire 3L(BK) to the 1/4" quick connect male terminal on the line side of the contactor (the bottom side) following the wiring diagrams in and .
18. Place the correct adhesive back wiring diagrams that match the unit (provided in the kit) onto the new control box cover front and back. [Figure 2, p. 6.](#)
19. Install the new control box cover, which is supplied in the kit. An extra screw is supplied in the kit to mount this cover.
20. Re-install the air handler's side panel.

2-Speed Unit Transformer

⚠ WARNING

Hazardous Voltage w/Capacitors!

Failure to disconnect power and discharge capacitors before servicing could result in death or serious injury.

Disconnect all electric power, including remote disconnects and discharge all motor start/run capacitors before servicing. Follow proper lockout/tagout procedures to ensure the power cannot be inadvertently energized. For variable frequency drives or other energy storing components provided by Trane or others, refer to the appropriate manufacturer's literature for allowable waiting periods for discharge of capacitors. Verify with a CAT III or IV voltmeter rated per NFPA 70E that all capacitors have discharged.

For additional information regarding the safe discharge of capacitors, see PROD-SVB06-EN.*

Figure 3. Remove transformer from enclosure

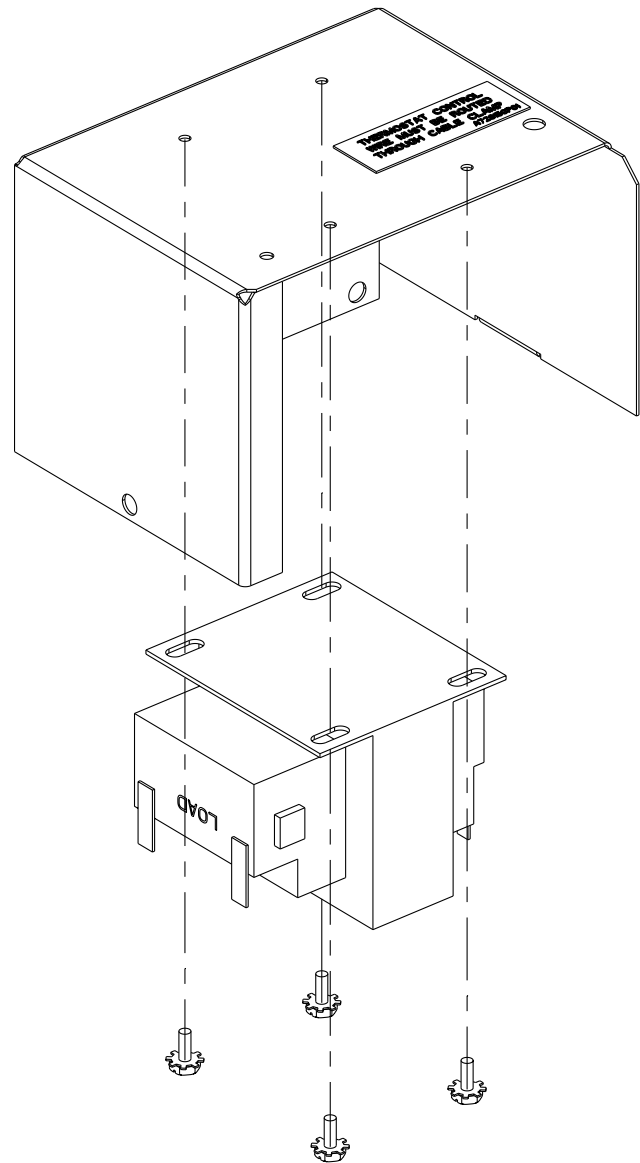
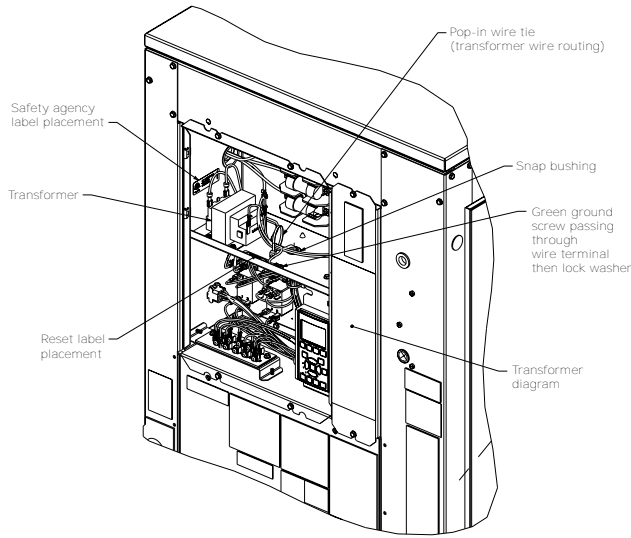

Figure 4. Transformer installation - 2-speed unit



1. Disconnect power from unit.
2. Remove transformer from enclosure. See [Figure 3, p. 7](#).
3. Identify the wire harness with wire numbers 27B (red) and 29B (black).
4. Connect wires 27B and 29B to L1 and L3 respectively of the load side of the fuse block. Wire colors should match.
5. Note voltage labels on primary of the transformer. Screw transformer into control box as shown in [Figure 4, p. 8](#). Ensure reset switch is facing out.
6. Connect wire 29B to COM on the primary of the transformer. Connect wire 27B to the appropriate tap on the primary of the transformer, corresponding to unit supply voltage.
7. Install pop-in wire tie and snap bushing as shown in [Figure 4, p. 8](#).
8. Connect wires 35P, 37T, and 36D to the secondary of the transformer as shown in . Attach ground wire 36D to control box using provided screw and lock washer.
9. Route wires 35P and 37T through snap bushing to LTB2 along with existing wiring. Connect 35P to LTB2-R and 37T to LTB2-B2 as shown in .
10. Neatly collect wire slack in pop-in wire tie. Use other wire ties to secure wires as desired.
11. Apply transformer diagram, reset label, and safety agency label in locations shown in [Figure 4, p. 8](#).

Wiring Diagrams

Figure 5. BAYTFMR011, BAYTFMR012, BAYTFMR013 - (one of two) single refrigerant circuit

TRANE <small>THIS DRAWING IS PROPRIETARY AND SHALL NOT BE COPIED OR ITS CONTENTS DISCLOSED TO OUTSIDE PARTIES WITHOUT THE CONSENT OF TRANE.</small>		FILE NUMBER:	DRAWING NUMBER: 12132178	SHEET: 1 OF 1	REV A
DRAWN BY: D. MCCAULEY		TRANE © DATE: 03/21/2017			
REPLACES:		REVISION DATE: --			
CAD SYSTEM USED: PRO/DIAGRAM		SIMILAR TO:			
ODYSSEY DIAGRAM AIR HANDLER - SINGLE CIRCUIT W/3 PHASE POWER					

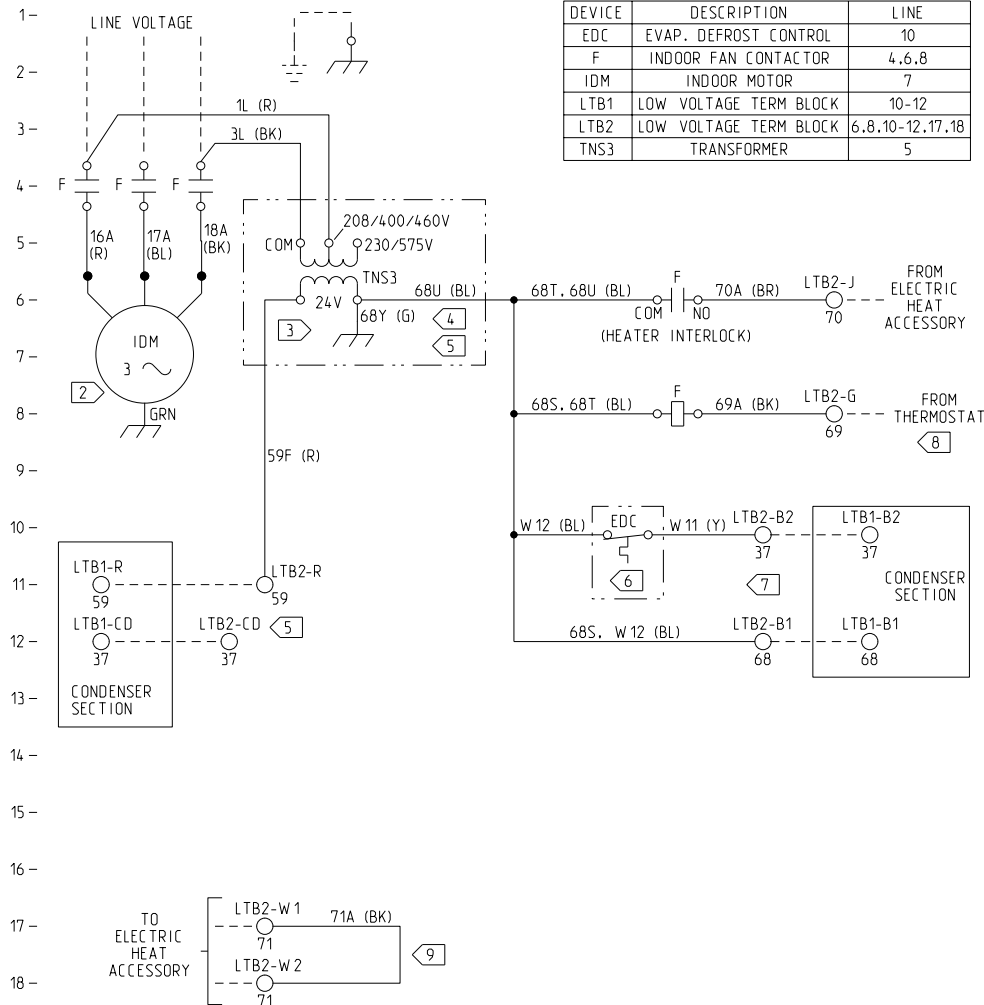

CAUTION USE COPPER CONDUCTORS ONLY! UNIT TERMINALS ARE NOT DESIGNED TO ACCEPT OTHER TYPES OF CONDUCTORS. FAILURE TO DO SO MAY CAUSE DAMAGE TO THE EQUIPMENT.	PRECAUCIÓN ¡UTILICE ÚNICAMENTE CONDUCTORES DE COBRE! LAS TERMINALES DE LA UNIDAD NO ESTÁN DISEÑADAS PARA ACEPTAR OTROS TIPOS DE CONDUCTORES SI NO LO HACE, PUEDE OCASIONAR DAÑO AL EQUIPO.	ATTENTION ¡UTILICE ÚNICAMENTE CONDUCTORES DE COBRE! LAS TERMINALES DE LA UNIDAD NO ESTÁN DISEÑADAS PARA ACEPTAR OTROS TIPOS DE CONDUCTORES SI NO LO HACE, PUEDE OCASIONAR DAÑO AL EQUIPO.
--	--	---

PRINTED FROM 12132178 REV A SHEET 1

Installation

Figure 6. BAYTFMR011, BAYTFMR012, BAYTFMR013 - (two of two) single refrigerant circuit

TRANE THIS DRAWING IS PROPRIETARY AND SHALL NOT BE COPIED OR ITS CONTENTS DISCLOSED TO OUTSIDE PARTIES WITHOUT THE CONSENT OF TRANE.		FILE NUMBER:	DRAWING NUMBER: 12132178	SHEET: 1 OF 1	REV A
DRAWN BY: D. MCCAULEY		ODYSSEY DIAGRAM			
TRANE © DATE: 03/27/2017		AIR HANDLER - SINGLE CIRCUIT W/3 PHASE POWER			
REPLACES:		REVISION DATE: ---			
CAD SYSTEM USED: PRO/DIAGRAM		SIMILAR TO:			

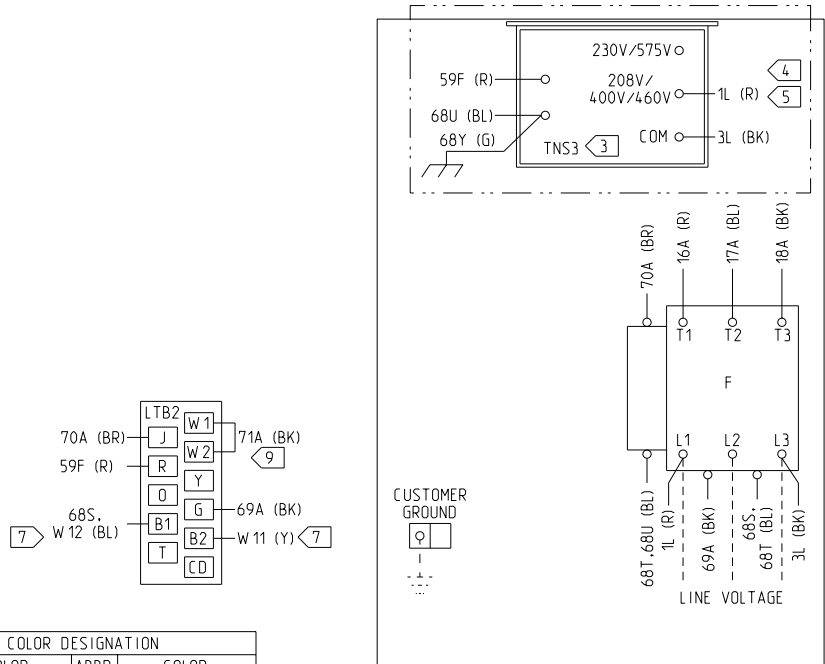

WIRE COLOR DESIGNATION			
ABBR	COLOR	ABBR	COLOR
BL	BLUE	O	ORANGE
BK	BLACK	R	RED
BR	BROWN	V	VIOLET (PURPLE)
G or GRN	GREEN	W	WHITE
GY	GRAY (SLATE)	Y	YELLOW

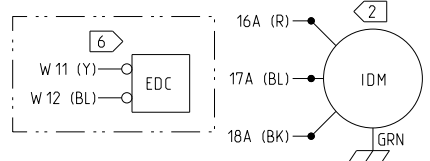

CAUTION
 USE COPPER CONDUCTORS ONLY! UNIT TERMINALS ARE NOT DESIGNED TO ACCEPT OTHER TYPES OF CONDUCTORS. FAILURE TO DO SO MAY CAUSE DAMAGE TO THE EQUIPMENT.

ATTENTION
 N'UTILISER QUE DES CONDUCTEURS EN CUIVRE! LES BORNES DE L'UNITÉ NE SONT PAS CONÇUES POUR RECEVOIR D'AUTRES TYPES DE CONDUCTEURS. L'UTILISATION DE TOUT AUTRE CONDUCTEUR PEUT ENDOMMAGER L'EQUIPEMENT.

PRECAUCIÓN
 ¡UTILICE ÚNICAMENTE CONDUCTORES DE COBRE! LAS TERMINALES DE LA UNIDAD NO ESTÁN DISEÑADAS PARA ACEPTAR OTROS TIPOS DE CONDUCTORES. SI NO LO HACE, PUEDE OCASIONAR DAÑO AL EQUIPO.

- NOTE:
- SEE FIELD WIRING DIAGRAMS IN PRODUCT LITERATURE FOR PROPER FIELD CONNECTIONS.
 - INDOOR FAN MOTOR (IDM) HAS INTERNAL OVERLOAD PROTECTION.
 - TNS3 (AND ASSOCIATED WIRING) USED ON 5 TON MODELS ONLY.
 - CONNECTIONS SHOWN ARE FOR 208V/400V/460V MODELS. FOR 230V/575V, WIRE 1L (R) IS CONNECTED TO THE APPROPRIATE TERMINAL ON THE TRANSFORMER.
 - 208V/230V UNITS ARE FACTORY WIRING FOR 230V POWER. FOR 208V POWER, CONNECT WIRE 1L (R) TO THE 208V TERMINAL ON THE TRANSFORMER.
 - THE EDC SWITCH IS NOT PROVIDED ON MODELS WITH CHILLED WATER COIL.
 - IF AIR HANDLER HAS AN EVAPORATOR DEFROST CONTROL (EDC) ON MODELS WITH RELIATEL CONTROLS, INSTALLER MUST MOVE WIRES W11 (Y) AND W12 (BL) FROM LTB2 TERMINALS "B2" AND "B1" (ON AIR HANDLER) TO "R" AND "CD".
 - ON ELECTRO-MECHANICAL UNITS, MAKE CONNECTION DIRECTLY FROM THERMOSTAT. ON RELIATEL UNITS, MAKE CONNECTION FROM LTB1-EF IN CONDENSER.
 - REMOVE JUMPER WIRE 71A (BK) TO ALLOW TWO STAGES OF ELECTRIC HEAT.

PRINTED FROM 12132178 REV A SHEET 2

Figure 7. BAYTFMR011, BAYTFMR012, BAYTFMR013 - (one of two) dual refrigerant circuit

TRANE <small>THIS DRAWING IS PROPRIETARY AND SHALL NOT BE COPIED OR ITS CONTENTS DISCLOSED TO OUTSIDE PARTIES WITHOUT THE CONSENT OF TRANE.</small>		FILE NUMBER:	DRAWING NUMBER:	SHEET:	REV
			12132176	1 OF 1	A
DRAWN BY: D. MCCAULEY TRANE @ DATE: 03/27/2017		ODYSSEY DIAGRAM AIR HANDLER - DUAL CIRCUIT W/3 PHASE POWER			
REPLACES:					
CAD SYSTEM USED: PRO/DIAGRAM					

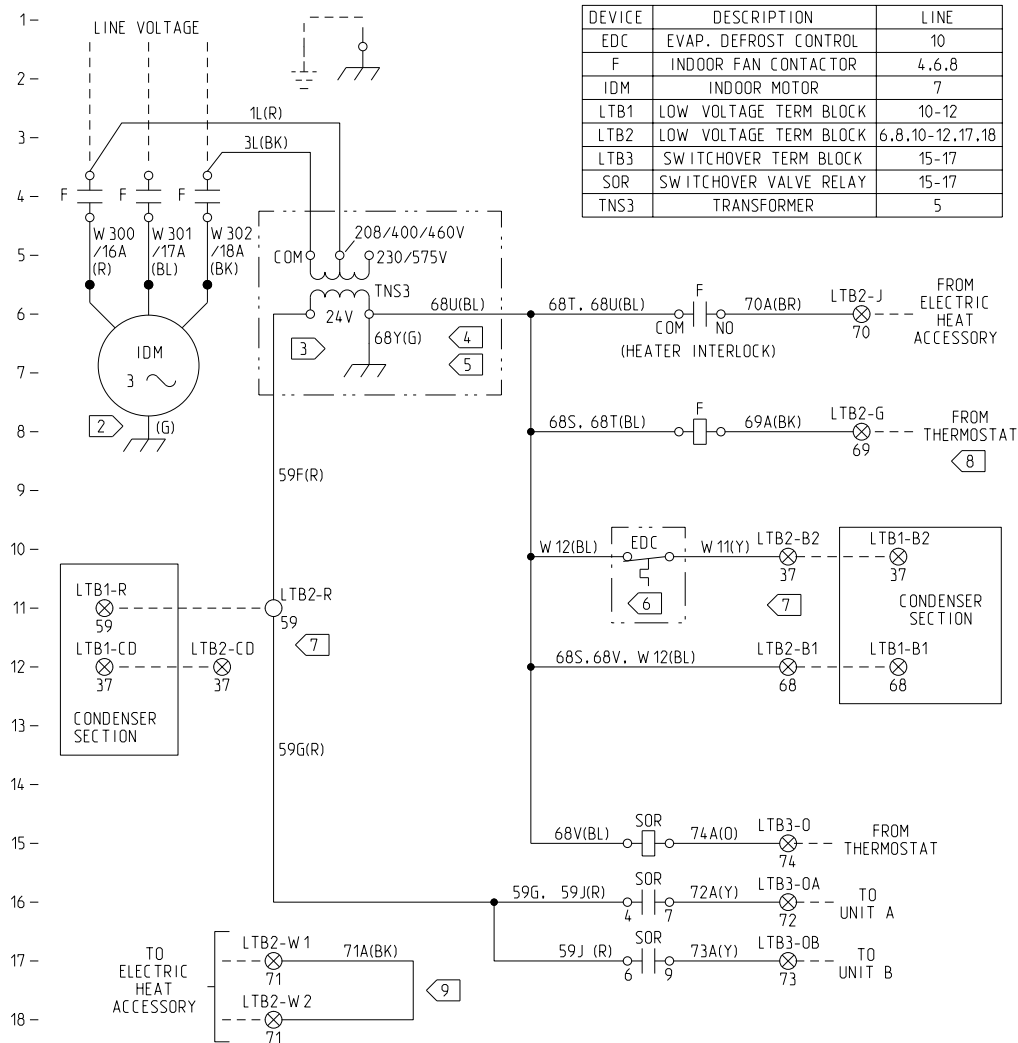

PRINTED FROM 12132176 REV A SHEET 1

Figure 8. BAYTFMR011, BAYTFMR012, BAYTFMR013 - (two of two) dual refrigerant circuit

TRANE <small>THIS DRAWING IS PROPRIETARY AND SHALL NOT BE COPIED OR ITS CONTENTS DISCLOSED TO OUTSIDE PARTIES WITHOUT THE CONSENT OF TRANE.</small>		FILE NUMBER:	DRAWING NUMBER: 12132176	SHEET: 1 OF 1	REV A
DRAWN BY: D. MCCAULEY	TRANE @ DATE: 03/27/2017	ODYSSEY DIAGRAM AIR HANDLER - DUAL CIRCUIT W/3 PHASE POWER			
REPLACES:	REVISION DATE:				
CAD SYSTEM USED: PRO/DIAGRAM	SIMILAR TO:				

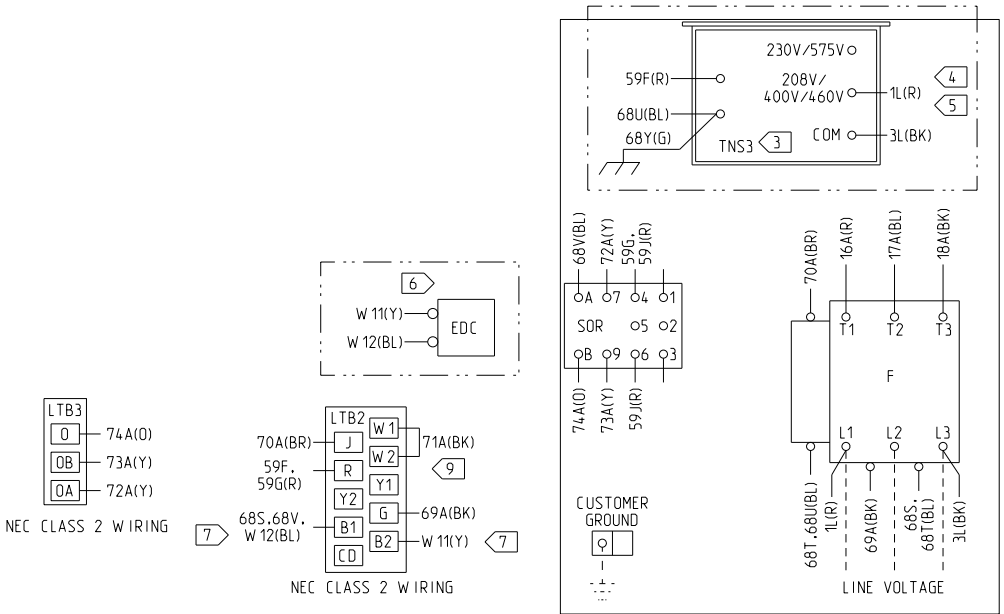

WIRE COLOR DESIGNATION			
ABBR	COLOR	ABBR	COLOR
BL	BLUE	O	ORANGE
BK	BLACK	R	RED
BR	BROWN	V	VIOLET (PURPLE)
G	GREEN	W	WHITE
GY	GRAY (SLATE)	Y	YELLOW

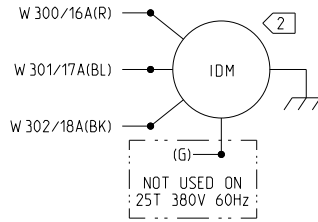
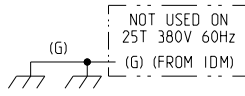

CAUTION
 USE COPPER CONDUCTORS ONLY!
 UNIT TERMINALS ARE NOT DESIGNED TO ACCEPT OTHER TYPES OF CONDUCTORS. FAILURE TO DO SO MAY CAUSE DAMAGE TO THE EQUIPMENT.

ATTENTION
 N'UTILISER QUE DES CONDUCTEURS EN CUIVRE! LES BORNES DE L'UNITÉ NE SONT PAS CONÇUES POUR RECEVOIR D'AUTRES TYPES DE CONDUCTEURS. L'UTILISATION DE TOUT AUTRE CONDUCTEUR PEUT ENDOMMAGER L'EQUIPEMENT.

PRECAUCIÓN
 ¡UTILICE ÚNICAMENTE CONDUCTORES DE COBRE! LAS TERMINALES DE LA UNIDAD NO ESTÁN DISEÑADAS PARA ACEPTAR OTROS TIPOS DE CONDUCTORES. SI NO LO HACE, PUEDE OCASIONAR DAÑO AL EQUIPO.

- NOTE:
- SEE FIELD WIRING DIAGRAMS IN PRODUCT LITERATURE FOR PROPER FIELD CONNECTIONS.
 - INDOOR FAN MOTOR (IDM) HAS INTERNAL OVERLOAD PROTECTION.
 - TNS3 (AND ASSOCIATED WIRING) USED ON 5 TON MODELS ONLY.
 - CONNECTIONS SHOWN ARE FOR 208V/400V/460V MODELS. FOR 230V/575V, WIRE 1L(R) IS CONNECTED TO THE APPROPRIATE TERMINAL ON THE TRANSFORMER.
 - 208V/230V UNITS ARE FACTORY WIRED FOR 230V POWER. FOR 208V POWER, CONNECT WIRE 1L(R) TO THE 208V TERMINAL ON THE TRANSFORMER.
 - THE EDC SWITCH IS NOT PROVIDED ON MODELS WITH CHILLED WATER COIL.
 - IF AIR HANDLER HAS AN EVAPORATOR DEFROST CONTROL (EDC) ON MODELS WITH RELIATEL CONTROLS, INSTALLER MUST MOVE WIRES W11(Y) AND W12(BL) FROM LTB2 TERMINALS "B2" AND "B1" (ON AIR HANDLER) TO "R" AND "CD".
 - ON ELECTRO-MECHANICAL UNITS, MAKE CONNECTION DIRECTLY FROM THERMOSTAT. ON RELIATEL UNITS, MAKE CONNECTION FROM LTB1-EF IN CONDENSER.
 - REMOVE JUMPER WIRE 71A(BK) TO ALLOW TWO STAGES OF ELECTRIC HEAT.

Figure 9. Transformer diagram - 2 speed air handler with staged condensers

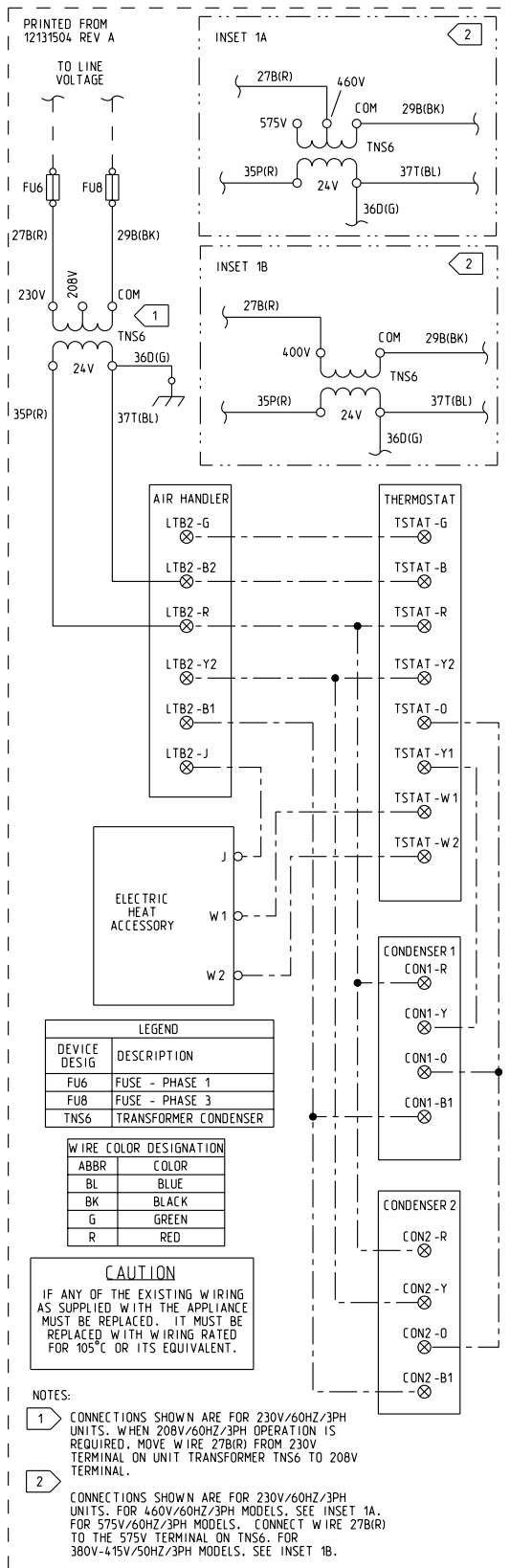

Trane and American Standard create comfortable, energy efficient indoor environments for residential applications. For more information, please visit trane.com or americanstandardair.com.

Trane and American Standard have a policy of continuous product and product data improvement and reserve the right to change design and specifications without notice. We are committed to using environmentally conscious print practices.

ACC-SVN121G-EN 28 Apr 2020
Supersedes ACC-SVN121F-EN (September 2017)

©2020