



41- 5010- 25

# INSTALLATION, OPERATION, AND MAINTENANCE GUIDE

ALL phases of this installation must comply with NATIONAL, STATE AND LOCAL CODES

**Model:**

CUB1A040A9241A	CUB1D120A9601A
CUB1A060A9241A	CUB1D140A9601A
CUB1A060A9361A	
CUB1B060A9361A	CDB1A060A9361A
CUB1B080A9361A	CDB1B060A9361A
CUB1B080A9481A	CDB1B080A9451A
CUB1B100A9361A	CDB1B100A9451A
CUB1C100A9481A	CDB1C100A9601A
CUB1C100A9601A	CDB1D120A9601A

## Upflow Only and Downflow / Horizontal, Gas-Fired Furnaces “Fan Assisted Combustion System”

**IMPORTANT**—This Document is customer property and is to remain with this unit.  
Please return to service information pack upon completion of work.

**For VENT SIZING INFORMATION see:**

**USA —**  
National Fuel Gas Code ..... ANSI Z223.1/NFPA 54 (latest version)

**CANADA —**  
Natural Gas Installation Code ..... CAN/CGA-B149.1 (latest version)  
Propane Installation Code ..... CAN/CGA-B149.2 (latest version)

**USA/CANADA ALTERNATE —**  
Category I Venting Guide ..... Pub. No. 18-CH23D1-2

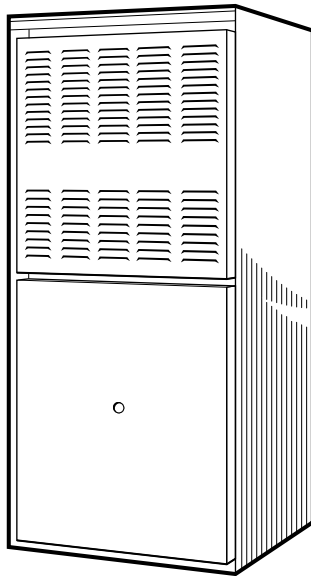

**Upflow only**

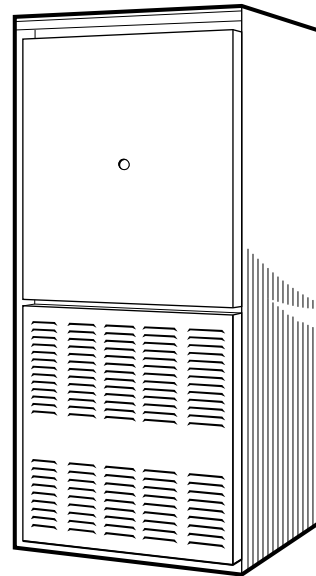

**Downflow / Horizontal\***

\*Horizontal Conversion for these furnaces may be left or right side rotation.

The following safety practices and precautions must be followed during the installation, servicing, and operation of this furnace.

1. Use only with the type of gas approved for this furnace. Refer to the furnace rating plate.
2. Install this furnace only in a location and position as specified in "Location and Clearances" (pages 3 & 6), of these instructions.
3. Provide adequate combustion and ventilation air to the furnace space as specified in "Air for Combustion and Ventilation" (pages 7 & 8), of these instructions.
4. Combustion products must be discharged outdoors. Connect this furnace to an approved vent system only, as specified in the "Venting" section (pages 11-12), of these instructions.
5. Never test for gas leaks with an open flame. Use a commercially available soap solution made specifically for the detection of leaks to check all connections, as specified in "Gas Piping" (page 14), of these instructions.
6. Always install the furnace to operate within the furnace's intended temperature-rise range with a duct system which has an external static pressure within the allowable range, as specified on the unit rating plate. Airflow with temperature rise for cfm versus static is shown in the Service Facts accompanying this furnace.
7. When a furnace is installed so that supply ducts carry air circulated by the furnace to areas outside the space containing the furnace, the return air shall also be handled by a duct(s) sealed to the furnace casing and terminating outside the space containing the furnace.
8. A gas-fired furnace for installation in a residential garage must be installed as specified in "Location and Clearances" section (pages 3 & 6), of these instructions.
9. The furnace may be used for temporary heating of buildings or structures under construction only when the following conditions have been met:
  - a. The furnace venting system must be complete and installed per manufacturer's instructions.
  - b. The furnace is controlled only by a room thermostat (no field jumpers).
  - c. The furnace return air duct must be complete and sealed to the furnace and clean air filters are in place.
  - d. The furnace input rate and temperature rise must be verified to be within nameplate marking.
  - e. 100% of the furnace combustion air requirement must come from outside the structure.
  - f. The furnace return air temperature range is between 55 and 80 degrees Fahrenheit.
  - g. Clean the furnace, duct work, and components upon substantial completion of the construction process, and verify furnace operating conditions including ignition, input rate, temperature rise and venting, according to the manufacturer's instructions.
10. This product must be gas piped by a Licensed Plumber or Gas Fitter in the Commonwealth of Massachusetts.

Safety signal words are used to designate a degree or level of seriousness associated with a particular hazard. The signal words for safety markings are **WARNING**, and **CAUTION**.

- a. **WARNING** indicates a potentially hazardous situation which, if not avoided, could result in death or serious injury.

### **WARNING**

#### **CARBON MONOXIDE POISONING HAZARD**

**Failure to follow the steps outlined below for each appliance connected to the venting system being placed into operation could result in carbon monoxide poisoning or death.**

The following steps shall be followed for each appliance connected to the venting system being placed into operation, while all other appliances connected to the venting system are not in operation:

1. Seal any unused openings in the venting system.
2. Inspect the venting system for proper size and horizontal pitch, as required in the National Fuel Gas Code, ANSI Z223.1/NFPA 54 or the CAN/CGA B149 Installation Codes and these instructions. Determine that there is no blockage or restriction, leakage, corrosion and other deficiencies which could cause an unsafe condition.
3. As far as practical, close all building doors and windows and all doors between the space in which the appliance(s) connected to the venting system are located and other deficiencies which could cause an unsafe condition.
4. Close fireplace dampers.
5. Turn on clothes dryers and any appliance not connected to the venting system. Turn on any exhaust fans, such as range hoods and bathroom exhausts, so they are operating at maximum speed. Do not operate a summer exhaust fan.
6. Follow the lighting instructions. Place the appliance being inspected into operation. Adjust the thermostat so appliance is operating continuously.
7. If improper venting is observed during any of the above tests, the venting system must be corrected in accordance with the National Fuel Gas Code, ANSI Z221.1/NFPA 54 and/or CAN/CGA B149 Installation Codes.
8. After it has been determined that each appliance connected to the venting system properly vents where tested as outlined above, return doors, windows, exhaust fans, fireplace dampers and any other gas-fired burning appliance to their previous conditions of use.

- b. **CAUTION** indicates a potentially hazardous situation which, if not avoided, may result in minor or moderate injury. It is also used to alert against unsafe practices and hazards involving only property damage.

### **WARNING**

#### **FIRE OR EXPLOSION HAZARD**

**Failure to follow the safety warnings exactly could result in serious injury, death or property damage.**

**Improper servicing could result in dangerous operation, serious injury, death, or property damage.**

### **WARNING**

#### **EXPLOSION HAZARD GAS IS UNDER PRESSURE.**

**FAILURE TO FOLLOW WARNING COULD RESULT IN SERIOUS PERSONAL INJURY, PROPERTY DAMAGE, OR DEATH.**

## CONTENTS

<b>INSTALLATION INSTRUCTIONS</b> .....	<b>3</b>
General Installation Instructions .....	3
Location and Clearances .....	3
<b>Outline Drawings</b> .....	<b>4-5</b>
Horizontal Installation .....	6
Air For Combustion and Ventilation .....	7
Duct Connections .....	8
Return Air Filters .....	9
General Venting Instructions .....	11
Venting Into a Masonry Chimney .....	11
Electrical Connections .....	12
<b>Field Wiring Diagrams</b> .....	<b>13</b>
Gas Piping .....	14
Sequence of Operation .....	14&28
<b>Start-up and Adjustment</b> .....	<b>15</b>
Preliminary Inspections .....	15
Combustion and Input Check .....	15
High Altitude Derate .....	16
Control and Safety Switch Adjustment .....	17
<b>OPERATING INSTRUCTIONS</b> .....	<b>18-24</b>
Lighting Instructions .....	19
Main Gas Cutoff Locations .....	19-20
Filter Replacement .....	21
Problem Solver .....	23
Regular Dealer Maintenance .....	24
<b>MAINTENANCE AND SERVICE</b> .....	<b>25-35</b>
Product Specifications – Upflow .....	25-26
Product Specifications – Downflow .....	27
Sequence of Operation .....	28
Airflow Adjustment .....	28
Abnormal Conditions .....	28
IFC Error Flash Codes .....	28
Upflow Wiring Diagrams .....	29-30
Downflow Wiring Diagrams .....	31-32
Upflow Airflow Table .....	33
Upflow CFM vs. Temp Rise Table .....	33
Downflow Airflow Table .....	34
Downflow CFM vs. Temp Rise Table .....	34
Periodic Servicing Requirements .....	35
Warranties .....	36-37

## GENERAL

The manufacturer assumes no responsibility for equipment installed in violation of any code or regulation. It is recommended that Manual J of the Air Conditioning Contractors Association (ACCA) or A.R.I. 230 be followed in estimating heating requirements. When estimating heating requirements for installation at Altitudes above 2000 ft., remember the gas input must be reduced (See GAS INPUT ADJUSTMENT).

**Material in this shipment has been inspected at the factory and released to the transportation agency without known damage. Inspect exterior of carton for evidence of rough handling in shipment. Unpack carefully after moving equipment to approximate location. If damage to contents is found, report the damage immediately to the delivering agency.**

Codes and local utility requirements governing the installation of gas fired equipment, wiring, plumbing, and flue connections must be adhered to. In the absence of local codes, the installa-

tion must conform with the National Installation Code, CAN/CGA B149.1. The latest code may be obtained from the American Gas Association Laboratories, 400 N. Capitol St. NW, Washington D.C. 20001. 1-800-699-9277 or www.aga.org

These furnaces have been classified as Fan Assisted Combustion system CATEGORY I furnaces as required by ANSI Z21.47 “latest edition” and CAN/CGA 2.3. Therefore they do not require any special provisions for venting other than what is indicated in these instructions. (Category I defined page 11).

## ⚠ CAUTION

**To prevent shortening its service life, the furnace should not be used as a “Construction Heater” during the finishing phases of construction until the requirements listed in item 9, a-g of the safety section of this publication have been met. Condensate in the presence of chlorides and fluorides from paint, varnish, stains, adhesives, cleaning compounds, and cement create a corrosive condition which may cause rapid deterioration of the heat exchanger.**

## ⚠ WARNING

**These furnaces are not approved or intended for installation in manufactured (mobile) housing, trailers, or recreational vehicles. Failure to follow this warning could result in property damage, personal injury, or death.**

## ⚠ CAUTION

**Do not install the furnace in a corrosive or contaminated atmosphere.**

## LOCATION AND CLEARANCES

The location of the furnace is normally selected by the architect, the builder, or the installer. However, before the furnace is moved into place, be sure to consider the following requirements:

1. Is the location selected as near the chimney or vent and as centralized for heat distribution as practical?
2. Do all clearances between the furnace and enclosure equal or exceed the minimums stated in Clearance Table on the Outline Drawings.
3. Is there sufficient space for servicing the furnace and other equipment? A minimum of 24 inches front accessibility to the furnace must be provided. Any access door or panel must permit removal of the largest component.
4. Are there at least 3 inches of clearance between the furnace combustion air openings in the front panel and any closed panel or door provided?
5. Are the ventilation and combustion air openings large enough and will they remain unobstructed? If outside air is used, are the openings set above the highest snow accumulation level? (See the Air for Combustion and Ventilation section.)
6. Allow sufficient height in supply plenum above the furnace to provide for cooling coil installation, if the cooling coil is not installed at the time of this furnace installation.
7. A furnace shall be installed so electrical components are protected from water.
8. If the furnace is installed in a **residential garage**, it must be installed so that the burners, and the ignition source are located not less than 18 inches above the floor and the furnace must be located or protected to avoid physical damage from vehicles.

# Installation Instructions

## CUB-A OUTLINE DRAWING

(ALL DIMENSIONS ARE IN INCHES)

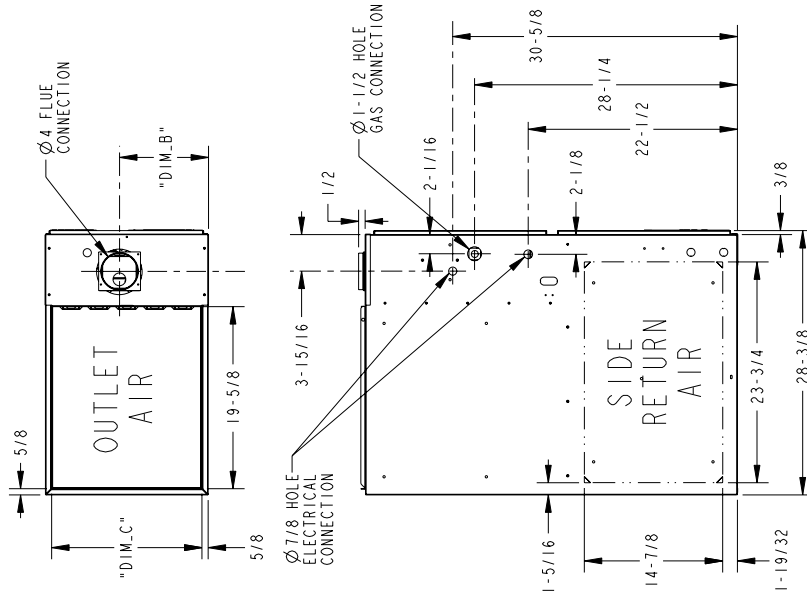

CLEARANCE FROM COMBUSTIBLE MATERIALS	
LEFT SIDE	0"
RIGHT SIDE	3" (SEE NOTE 1)
REAR	0"
FRONT	3" (SEE NOTE 3)
TOP	1"
FLUE	6" (SEE NOTE 2)

- NOTES:**
- FOR 14-1/2" CABINETS, 0" WHEN TYPE B-1 VENT IS USED, 1" WHEN TYPE B-1 VENT IS USED.
  - MINIMUM CLEARANCE TO FRONT ON CUB140A960A IS 6".

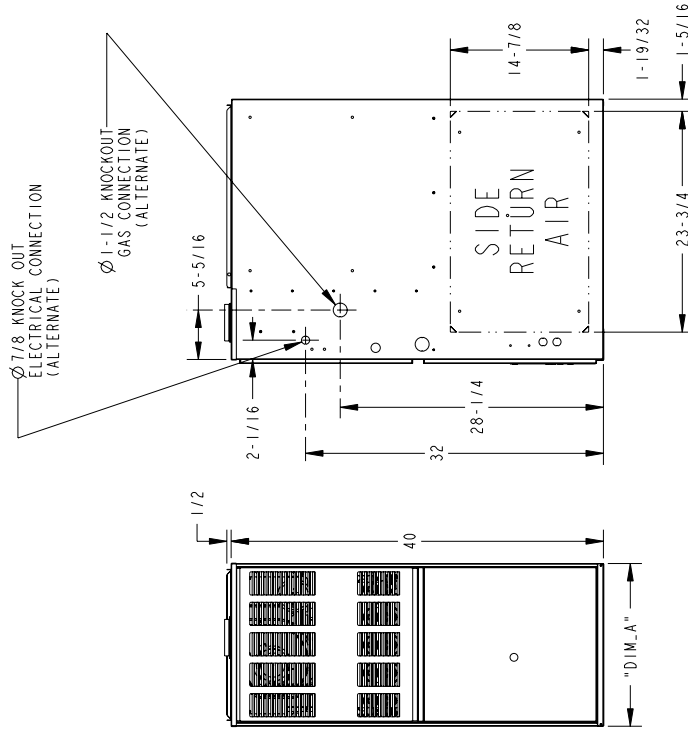

MODEL	DIM "A"	DIM "B"	DIM "C"	DIM "D"
CUB1A040A9241^^	14-1/2"	9-5/8"	13-1/4"	13"
CUB1A060A9241^^	17-1/2"	9-5/8"	16-1/4"	16"
CUB1A060A9361^^	21"	13-1/16"	19-3/4"	19-1/2"
CUB1B060A9361^^	24-1/2"	15-5/16"	23-1/4"	23"
CUB1B080A9361^^				
CUB1B080A9481^^				
CUB1B100A9361^^				
CUB1C100A9481^^				
CUB1C100A9601^^				
CUB1D120A9601^^				
CUB1D140A9601^^				

^^ SUFFIX LETTER MAY BE AA THRU ZZ

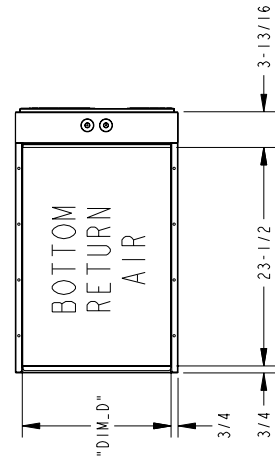

**CDB-A OUTLINE DRAWING**

(ALL DIMENSIONS ARE IN INCHES)

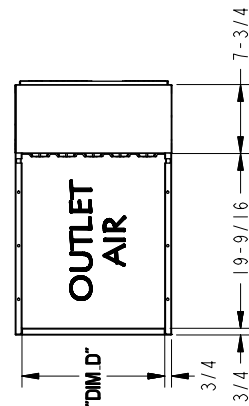
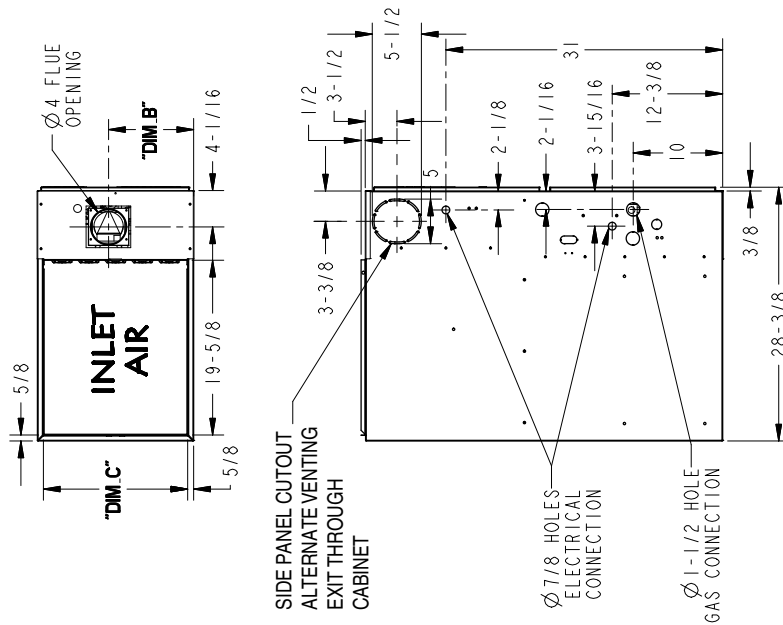

**MINIMUM CLEARANCE TO COMBUSTIBLE MATERIALS**

**DOWNFLOW CLOSET**

TOP 3\* IN. W/SINGLE WALL VENT - 0 IN. W/TYPE B-1 VENT  
 FLUE 6 IN. W/SINGLE WALL VENT - 1 IN. W/TYPE B-1 VENT  
 FRONT 6 IN. BACK 1 IN.  
 \* RIGHT SIDE ONLY FOR 14.5" CABINETS,  
 0 IN. TO LEFT SIDE, 0 IN. FOR REMAINING  
 CABINET SIZES (17.5", 21.0", 24.5").  
 - FOR INSTALLATION ON COMBUSTIBLE FLOORING ONLY  
 WHEN INSTALLED ON SPECIAL BASE - PART # BAYBASE 205

**HORIZONTAL CLOSET (FLUE DISCHARGE LEFT)**

TOP 3\* IN. W/SINGLE WALL VENT - 2 IN. W/TYPE B-1 VENT  
 FLUE 6 IN. W/SINGLE WALL VENT - 1 IN. W/TYPE B-1 VENT  
 FRONT 6 IN. BACK 3 IN.  
 \* TOP ONLY FOR 14.5" CABINETS.  
 2 IN. FOR REMAINING CABINET  
 SIZES (17.5", 21.0", 24.5").

**HORIZONTAL CLOSET (FLUE DISCHARGE RIGHT)**

TOP 2 IN. W/SINGLE WALL VENT - 1 IN. W/TYPE B-1 VENT  
 FLUE 6 IN. W/SINGLE WALL VENT - 1 IN. W/TYPE B-1 VENT  
 FRONT 6 IN. BACK 3 IN.  
 - FOR INSTALLATION ON COMBUSTIBLE FLOORING ONLY  
 WHEN B-1 VENT CONNECTOR IS USED.

**HORIZONTAL ALCOVE (FLUE DISCHARGE LEFT)**

TOP 3\* IN. W/SINGLE WALL VENT - 1 IN. W/TYPE B-1 VENT  
 FLUE 6 IN. W/SINGLE WALL VENT - 1 IN. W/TYPE B-1 VENT  
 FRONT 18 IN. BACK 0 IN.  
 \* TOP ONLY FOR 14.5" CABINETS,  
 1 IN. FOR REMAINING CABINET  
 SIZES (17.5", 21.0", 24.5").

**HORIZONTAL ALCOVE (FLUE DISCHARGE RIGHT)**

TOP 1 IN. W/SINGLE WALL VENT - 1 IN. W/TYPE B-1 VENT  
 FLUE 6 IN. W/SINGLE WALL VENT - 1 IN. W/TYPE B-1 VENT  
 FRONT 18 IN. BACK 0 IN.

Ø 7/8 KNOCKOUT  
 ELECTRICAL CONNECTION  
 (ALTERNATE)  
 Ø 1-1/2 KNOCKOUT  
 GAS CONNECTION  
 (ALTERNATE)

MODEL	A	B	C	D
CDB060A936D**	14-1/4"	9-5/8"	13-1/4"	13"
CDB060A937D**				
CDB080A945D**	17-1/2"	9-5/8"	16-1/4"	16"
CDB100A945D**				
CDB100A960D**	21"	13-1/16"	19-3/4"	19-1/2"
CDB120A960D**	24-1/2"	15-5/16"	23-1/4"	23"

\*\* Suffix letter may be "A" through "Z"

# Installation Instructions

## UPFLOW INSTALLATION

Standoffs and screws (See Figure 1) are included with the cased coils for attachment to the furnace. There are clearance alignment holes near the bottom of the coil wrapper. Drill screws are used to

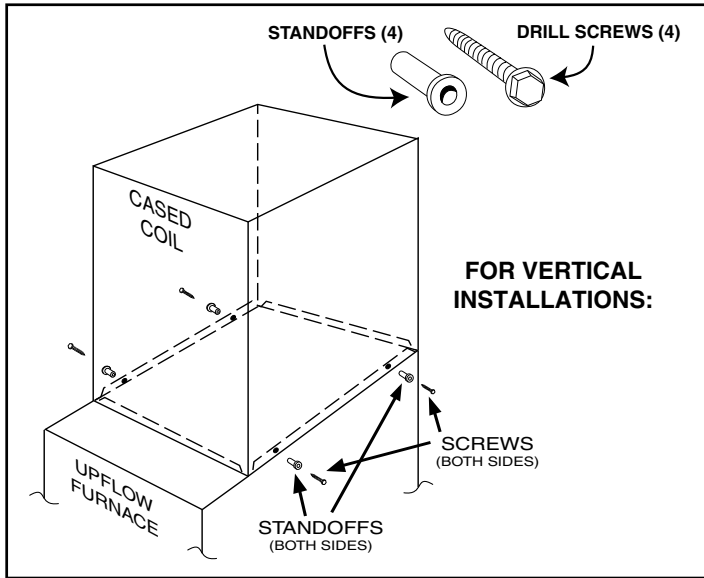

FIGURE 1

engage the furnace top flanges. The standoff is inserted into the cabinet alignment hole. The drill screws are inserted through the standoffs then screwed into the furnace flange. The coil is always placed downstream of the furnace airflow. The above instructions only apply if the coil is on top of an upflow furnace.

## DOWNFLOW INSTALLATION

### ⚠ WARNING

**Do not install the furnace directly on carpeting, tile or other combustible material other than wood flooring. For vertical downflow application, subbase (BAYBASE205) must be used between the furnace and combustible flooring. When the downflow furnace is installed vertically with a cased coil, a subbase is not required.**

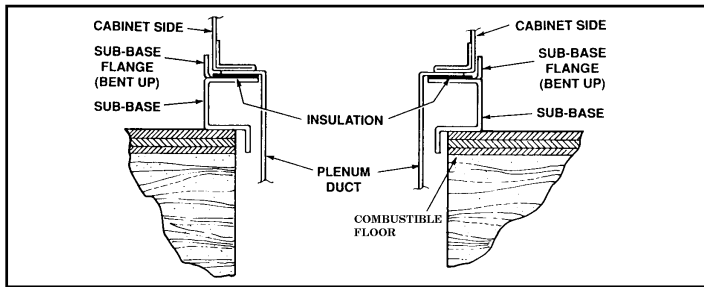

FIGURE 2

**Required floor opening: (DOWNFLOW)**  
See Figure 2 and Table 1

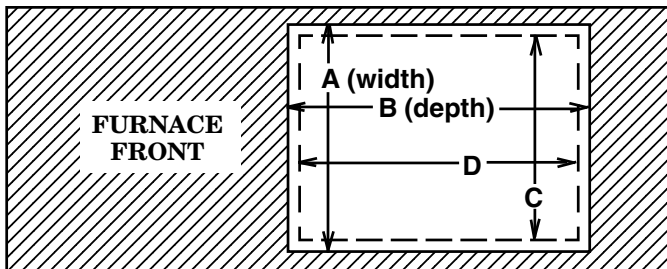

FIGURE 3

TABLE 1

CABINET WIDTH	RETURN DUCT WIDTH	FLOOR OPENING		PLENUM OPENING	
		"A"	"B"	"C"	"D"
14-1/2"	13-1/4"	13-5/8"	20-1/8"	12-5/8"	19-3/8"
17-1/2"	16-1/4"	16-5/8"	20-1/8"	15-5/8"	19-3/8"
21"	19-3/4"	20-1/8"	20-1/8"	19-1/8"	19-3/8"
24-1/2"	23-1/4"	23-5/8"	20-1/8"	22-5/8"	19-3/8"

## HORIZONTAL INSTALLATION

The coil and furnace must be fully supported when used in the horizontal position.

Three brackets (with screws) are included with downflow furnaces for installation to stabilize and secure the furnace and TXC cased coil in the **horizontal position** (See Figure 4). The coil is placed downstream of the furnace. The apex of the coil may point either towards or away from the furnace. The cased coil is secured to the furnace and both the furnace **and** the cased coil must be properly supported. The brackets mount using the rear screws on the coil case and use the screws provided to secure the bracket to the furnace. The remaining bracket is placed as close to center as possible (horizontally) between the coil case front and the furnace bottom channel (for downflow/horizontal furnace). Use four of the screws provided to secure the bracket.

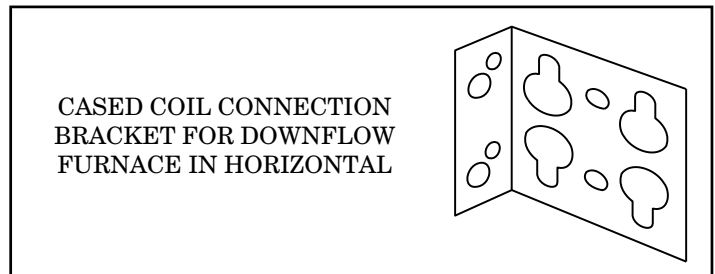

FIGURE 4

The downflow/horizontal furnace may be installed in an attic or crawl space in the horizontal position by placing the furnace on the left or right side (as viewed from the front in the upright position). The downflow/horizontal furnace installation in an attic should be on a service platform large enough to allow for proper clearances on all sides and service access to the front of the furnace (See Clearance Table on Outline Drawings and Figure 5).

If the furnace is suspended using perforated steel strap (plumber's strap), it must be supported at all four corners and in the middle at the front of the furnace. The forward most screw on the side of the furnace may be used to connect the strapping (See Figure 6). Line contact is only permissible between lines formed by the intersection of the top and two sides of the furnace casing and the building joists, studs, or framing.

A cutout is provided on both sides of the downflow furnace cabinet to allow a 90° elbow to be attached inside the cabinet and the vent piping to connect there. In horizontal, the downflow furnace may be vented through the top of the cabinet if needed. In vertical configuration, the downflow furnace may be vented using the side cabinet cutouts. This venting configuration could be used if an electronic air cleaner is installed. **When the downflow furnace is vented through the left side of the furnace cabinet in horizontal or vertical configuration, Type B vent pipe must be used within the cabinet.**

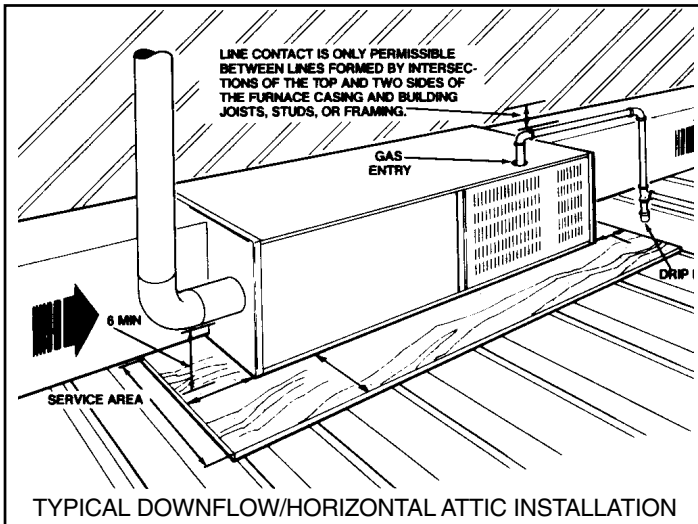

FIGURE 5

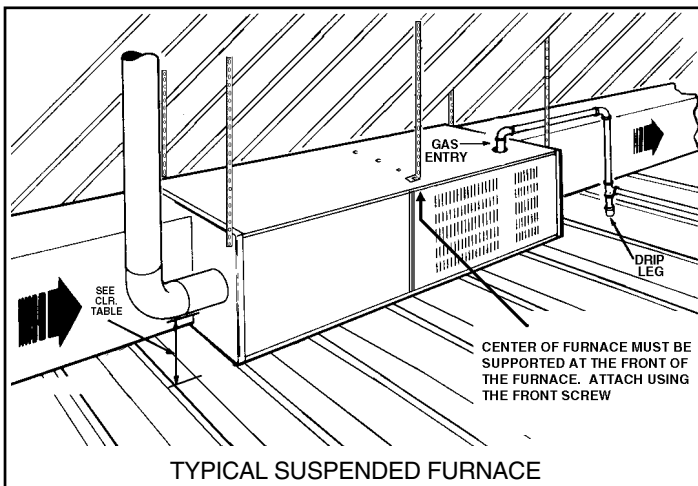

FIGURE 6

## AIR FOR COMBUSTION AND VENTILATION

Adequate flow of combustion and ventilating air must not be obstructed from reaching the furnace. Air openings provided in the furnace casing must be kept free of obstructions that restrict the flow of air. Airflow restrictions affect the efficiency and safe operation of the furnace. Keep this in mind should you choose to remodel or change the area which contains your furnace. Furnaces must have a free flow of air for proper performance.

Provisions for combustion and ventilation air shall be made in accordance with "latest edition" of Section 5.3, Air for Combustion and Ventilation, of the National Fuel Gas Code, ANSI Z223.1, or Sections 7.2, 7.3 or 7.4 of CAN/CGA B149 Installation Codes, and applicable provisions of the local building codes. Special conditions created by mechanical exhausting of air and fireplaces must be considered to avoid unsatisfactory furnace operation.

Furnace locations may be in "confined space" or "unconfined space". Unconfined space is defined in Table 2 and Figure 7. These spaces may have adequate air by infiltration to provide air for combustion, ventilation, and dilution of flue gases. Buildings with tight construction (for example, weather stripping, heavily insulated, caulked, vapor barrier, etc.), may need additional air provided as described for confined space.

Confined spaces are installations with less than 50 cu. ft. of space per 1000 BTU/hr input from all equipment installed. Air for combustion and ventilation requirements can be supplied from inside the building as in Figure 9 or from the outdoors, as in Figures 10 & 11.

Pub. No. 41-5010-25

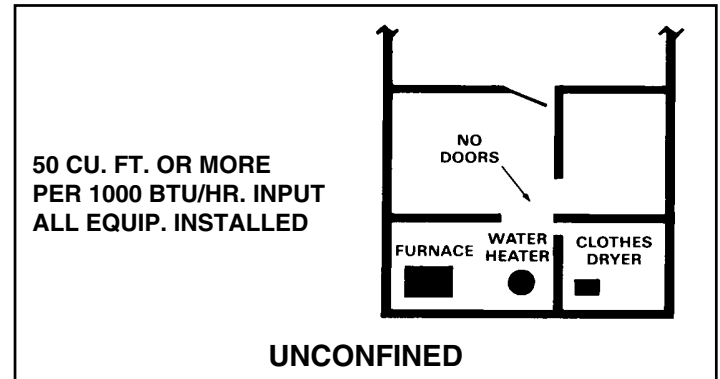

FIGURE 7

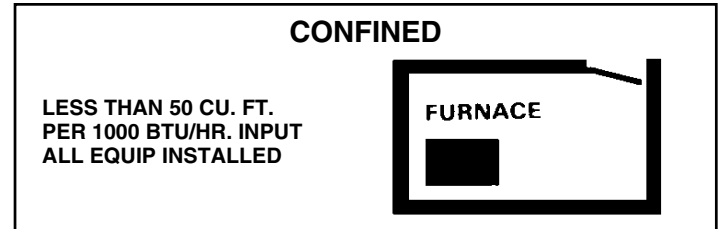

FIGURE 8

1. All air from inside the building as in Figure 9: The confined space shall be provided with two permanent openings communicating directly with an additional room(s) of sufficient volume so that the combined volume of all spaces meets the criteria for an unconfined space. The total input of all gas utilization equipment installed in the combined space shall be considered in making this determination. Refer to Table 3, for minimum open areas required.

2. All air from outdoors as in Figures 10 & 11: The confined space shall be provided with two permanent openings, one commencing within 12 inches of the top and one commencing within 12 inches of the bottom of the enclosure. The openings shall communicate directly, or by ducts, with the outdoors or spaces (crawl or attic) that freely communicate with the outdoors. Refer to Table 3, for minimum open areas required.

3. The following types of installations will **require** use of OUTDOOR AIR for combustion, due to chemical exposures:

- \* Commercial buildings
- \* Buildings with indoor pools
- \* Furnaces installed in commercial laundry rooms
- \* Furnaces installed in hobby or craft rooms
- \* Furnaces installed near chemical storage areas.

Exposure to the following substances in the combustion air supply will also require OUTDOOR AIR for combustion:

- \* Permanent wave solutions
- \* Chlorinated waxes and cleaners
- \* Chlorine based swimming pool chemicals
- \* Water softening chemicals
- \* Deicing salts or chemicals
- \* Carbon Tetrachloride
- \* Halogen type refrigerants
- \* Cleaning solvents (such as perchloroethylene)
- \* Printing inks, paint removers, varnish, etc.
- \* Hydrochloric acid
- \* Cements and glues
- \* Antistatic fabric softeners for clothes dryers
- \* Masonry acid washing materials

# Installation Instructions

TABLE 2

MINIMUM AREA IN SQUARE FEET FOR UNCONFINED SPACE INSTALLATIONS	
FURNACE MAXIMUM BTUH / INPUT RATING	WITH 8 FOOT CEILING MINIMUM AREA IN SQUARE FEET OF UNCONFINED SPACE
40,000	250
60,000	375
80,000	500
100,000	625
120,000	750
140,000	875

TABLE 3  
MINIMUM FREE AREA IN SQUARE INCHES  
EACH OPENING (FURNACE ONLY)

Furnace Maximum BTUH/INPUT Rating	Air From Inside	Air From Outside	
		Vertical Duct	Horizontal Duct
40,000	100	10	20
60,000	100	15	30
80,000	100	20	40
100,000	100	25	50
120,000	120	30	60
140,000	140	35	70

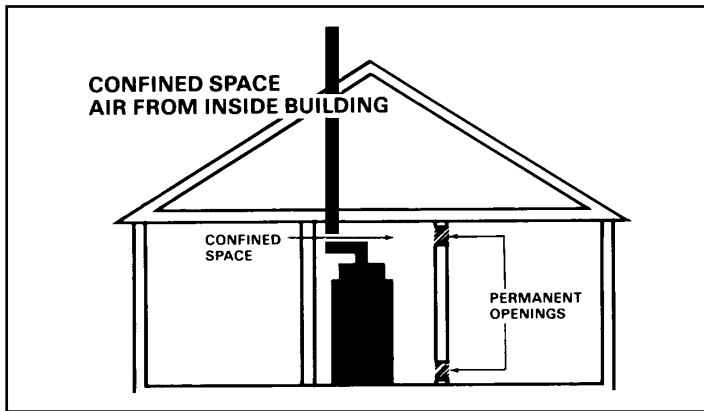

FIGURE 9

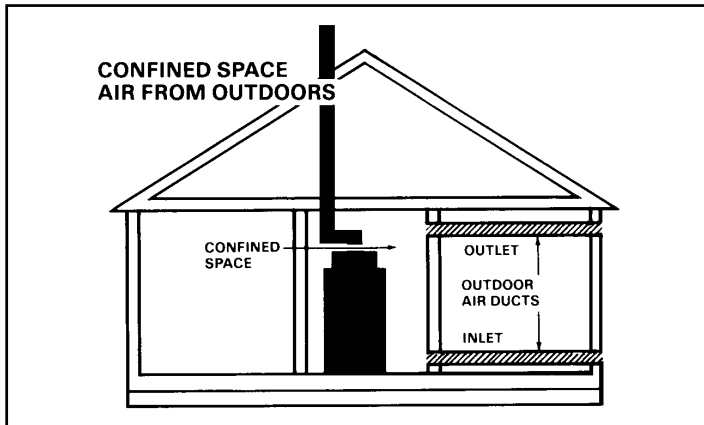

FIGURE 10

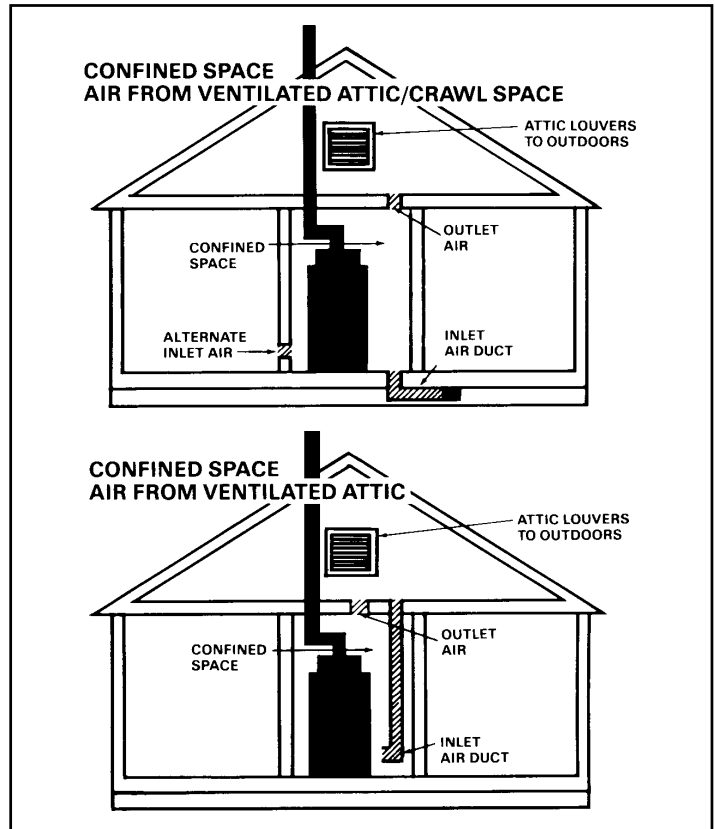

FIGURE 11

## DUCT CONNECTIONS

Air duct systems should be installed in accordance with standards for air conditioning systems, National Fire Protection Association Pamphlet No. 90. They should be sized in accordance with ACCA Manual D or whichever is applicable.

Central furnaces, when used in connection with cooling units, shall be installed in parallel or on the upstream side of the cooling units to avoid condensation in the heating element, unless the furnace has been specifically approved for downstream installation. With a parallel flow arrangement, the dampers or other means used to control flow of air shall be adequate to prevent chilled air from entering the furnace, and if manually operated, must be equipped with means to prevent operation of either unit unless the damper is in full heat or cool position.

On any job, flexible connections of nonflammable material may be used for return air and discharge connections to prevent transmission of vibration. Though these units have been specifically designed for quiet, vibration free operation, air ducts can act as sounding boards and could, if poorly installed, amplify the slightest vibration to the annoyance level.

When the furnace is located in a utility room adjacent to the living area, the system should be carefully designed with returns which minimize noise transmission through the return air grille. Although these winter air conditioners are designed with large blowers operating at moderate speeds, any blower moving a high volume of air will produce audible noise which could be objectionable when the unit is located very close to a living area. It is often advisable to route the return air ducts under the floor or through the attic. Such design permits the installation of air return remote from the living area (i.e. central hall).

When the furnace is installed so that the supply ducts carry air circulated by the furnace to areas outside the space containing the furnace, the return air shall also be handled by a duct(s) sealed to the furnace and terminating outside the space containing the furnace.



**Minimum return air “entering temperature” for the furnace is 50° F.**

Where there is no complete return duct system, the return connection must be run full size from the furnace to a location outside the utility room, basement, attic, or crawl space.

***Do Not install return air through the back of the furnace cabinet.***

***Do Not install return air through the side of the furnace cabinet on horizontal applications.***

### RETURN AIR DUCT CONNECTION

All return air duct systems should provide for installation of return air filters.

1. Set the furnace in place.
2. For side return installations on upflow models, remove the insulation around the opening in the blower compartment.
3. The side panels on upflow furnaces include locating notches which may be used as guides for cutting an opening for return air. Refer to Figure 12 and the Outline Drawing on page 4 for duct connection dimensions for various furnaces.
4. If a 3/4" flange is to be used for attaching the air inlet duct, add to cut where indicated by solid lines in Figure 12. Cut corners diagonally and bend outward to form flange.

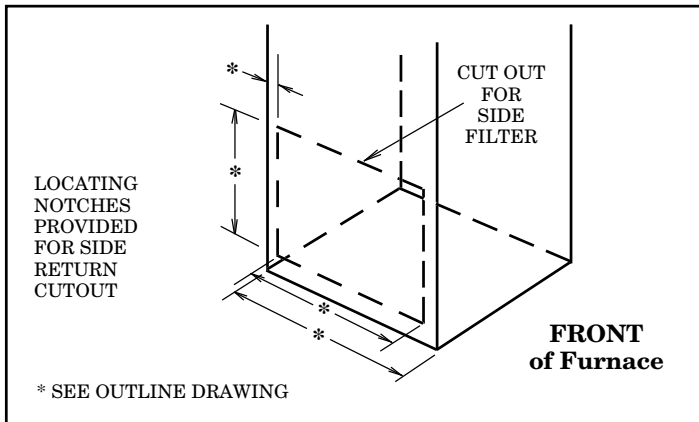

**FIGURE 12**

5. If flanges are not required, and a filter frame is installed, cut along knockout guidelines.

6. Upflow furnaces: filter retainer brackets are factory supplied (See Figure 14). Use the filter retainer brackets on either side or on bottom if filter is to be used within the furnace cabinet.

**NOTE:**

***On upflow 5 ton airflow models, if the airflow requirement exceeds 1800 CFM, these models will require return air openings and filters on both sides; OR 1 side and the bottom; OR just the bottom.***

7. Connect duct work to furnace. See Outline Drawing for supply and return duct size and location. Flexible duct connectors are recommended to connect both supply and return air ducts to the furnace. If only the front of the furnace is accessible, it is recommended that both supply and return air plenums are removable.

8. When replacing a furnace, old duct work should be cleaned out. Thin cloths should be placed over the registers and the furnace fan should be run for 10 minutes. Don't forget to remove the cloths before you start the furnace.

### RETURN AIR FILTER

Filters are field supplied for these furnaces. These furnaces require high velocity type air filters which may be located within the furnace blower compartment for UPFLOW furnaces in either a BOTTOM or SIDE (left side or right side) return air inlet. See Figure 14. Some filters may need to be trimmed for side or bottom filter use.

**NOTE:**

***On upflow 5 ton airflow models, if the airflow requirement exceeds 1800 CFM, these models will require return air openings and filters on both sides; OR 1 side and the bottom; OR just the bottom.***

Downflow furnace filters must be located outside the furnace cabinet. Typical installations are shown on page 10 in Figure 13. Tables 5 and 6 on page 10, provide information for installation of the filter retaining brackets shipped with downflow furnaces.

### FILTER RETAINER BRACKETS FOR UPFLOW FURNACES

If locating filter inside the furnace blower compartment is desired, it is necessary to install the 2 filter retainer brackets. Filter retainer brackets are shipped with the furnace in a plastic bag attached to the control platform. Follow the installation instructions included inside the plastic bag with the filter retainer brackets. (See Figure 14 “Typical Side Return Filter”).

**TABLE 4**

<b>REQUIRED FILTER SIZES - UPFLOW</b>			
<b>CABINET WIDTH</b>	<b>QTY (See Note)</b>	<b>CABINET BOTTOM FILTER</b>	<b>CABINET SIDE FILTER</b>
14-1/2"	1	14" X 25" X 1"	17" X 25" X 1"
17-1/2"	1	17" X 25" X 1"	17" X 25" X 1"
21"	1	20" X 25" X 1"	17" X 25" X 1"
24-1/2"	1	24" X 25" X 1"	17" X 25" X 1"

**\*NOTE -** On upflow 5 ton airflow models, if the airflow requirement exceeds 1800 CFM, these models will require return air openings and filters on both sides; OR 1 side and the bottom; OR just the bottom.

<b>REQUIRED FILTERS - DOWNFLOW</b>	
<b>CABINET WIDTH</b>	<b>FILTER QUANTITY &amp; SIZE</b>
14-1/2"	2 - 14" X 20" X 1"
17-1/2"	2 - 16" X 20" X 1"
21"	2 - 16" X 20" X 1"
24-1/2"	2 - 16" X 20" X 1"

# Installation Instructions

## TYPICAL DOWNFLOW FURNACE RETURN AIR FILTER INSTALLATIONS

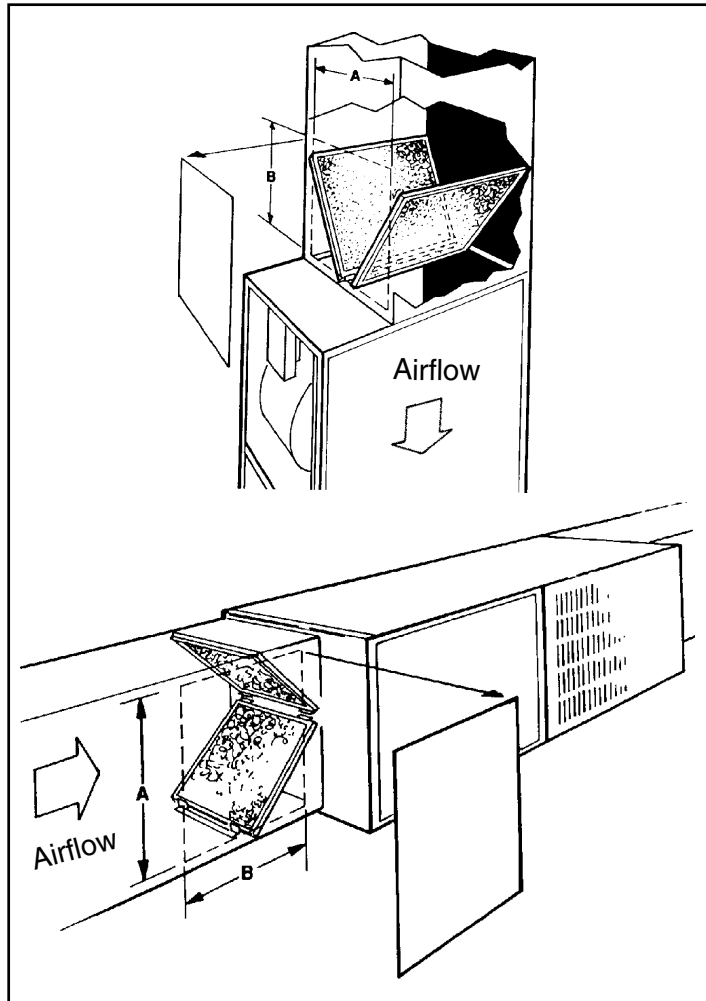

FIGURE 13

## TYPICAL UPFLOW FURNACE RETURN AIR FILTER INSTALLATIONS

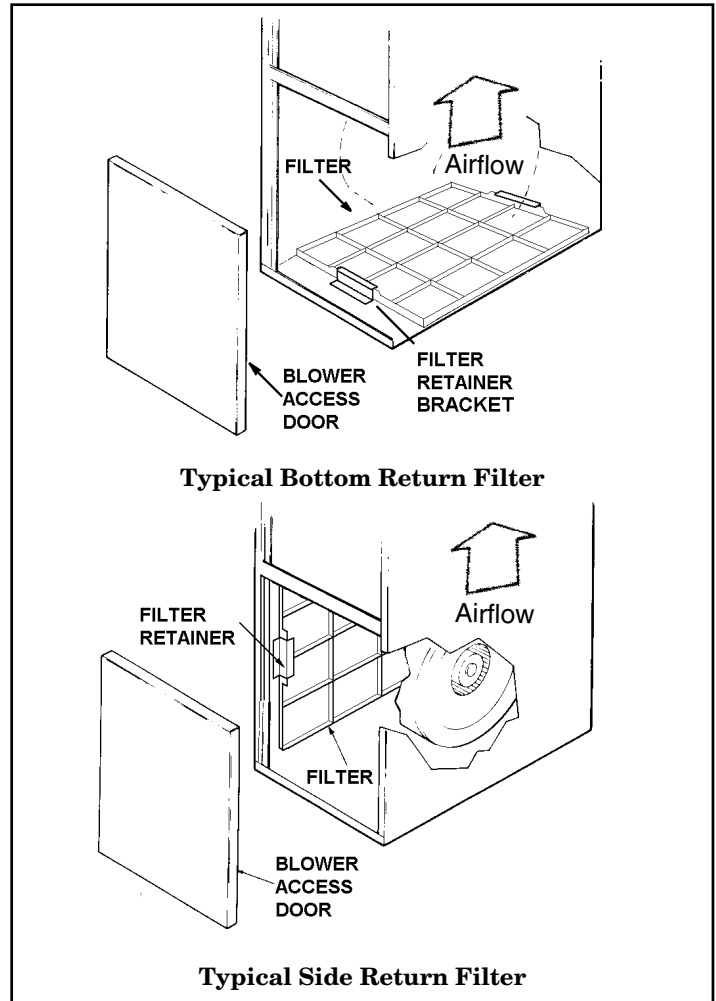

FIGURE 14

TABLE 5

CABINET WIDTH	FILTER SIZE	FILTER BRACKET LOCATION *
14-1/2"	2 - 14X20X1	12-7/8"
17-1/2"	2 - 16X20X1	14-3/8"
21"	2 - 16X20X1	13-1/8"
24-1/2"	2 - 16X20X1	11-5/8"

\* Location dimension is from end of duct to the screw holes for the bracket.

TABLE 6

CABINET WIDTH	RETURN DUCT WIDTH	FILTER ACCESS OPENING - DIMENSION "A"	FILTER ACCESS OPENING - DIMENSION "B"
14-1/2"	13-1/4"	12"	14"
17-1/2"	16-1/4"	15"	14"
21"	19-3/4"	19-1/2"	14"
24-1/2"	23-1/4"	22"	14"

## GENERAL VENTING INSTRUCTIONS

### VENT PIPING

These furnaces have been classified as Fan-Assisted Combustion System, Category I furnaces under the “latest edition” provisions of ANSI Z21.47 and CAN/CGA 2.3 standards. Category I furnaces operate with a non-positive vent static pressure and with a flue loss of not less than 17 percent.

**NOTE:**

*If desired, a sidewall termination can be accomplished through the use of an “add-on” draft inducer. The inducer must be installed according to the inducer manufacturer’s instructions. Set the barometric pressure relief to achieve -0.02 inch water column.*

**NOTE:**

*When the downflow furnace is vented through the left side of the furnace cabinet using the provided cutout, Type B vent piping must be used.*

The furnace shall be connected to a factory built chimney or vent complying with a recognized standard, or a masonry or concrete chimney lined with a lining material acceptable to the authority having jurisdiction.

### WARNING

**Furnace venting into an unlined masonry chimney or concrete chimney is prohibited. Failure to follow this warning could result in property damage, personal injury, or death.**

### VENTING INTO A MASONRY CHIMNEY

If the chimney is oversized, the liner is inadequate, or flue-gas condensation is a problem in your area, consider using the chimney as a pathway or chase for type “B” vent or flexible vent liner. If flexible liner material is used, size the vent using the “B” vent tables, then reduce the maximum capacity by 20% (multiply 0.80 times the maximum capacity).

#### Internal Masonry Chimneys

Venting of fan assisted appliances into a lined, internal masonry chimney is allowed only if it is common vented with at least one natural draft appliance; **OR**, if the chimney is lined with type “B”, double wall vent or suitable flexible liner material (See Table 7).

### WARNING

**The chimney liner must be thoroughly inspected to insure no cracks or other potential areas for flue gas leaks are present in the liner. Liner leaks will result in early deterioration of the chimney.**

**Failure to follow this warning could result in carbon monoxide poisoning or death.**

**TABLE 7  
MASONRY CHIMNEY VENTING**

Type Furnace	Tile Lined Chimney		Chimney Lining	
	Internal	External	“B” Vent	Flexible Metal
Single Fan Assist	No	No	Yes	Yes*
Fan Assist + Fan Assist	No	No	Yes	Yes*
Fan Assist + Natural	Yes	No	Yes	Yes*

\* Flexible chimney liner size is determined by using the type “B” vent size for the available BTUH input, then reducing the maximum capacity by 20% (multiply maximum capacity times 0.80). The minimum capacity is the same as shown in the “B” vent tables.

### External Masonry Chimney

Venting of fan assisted appliances into external chimneys (one or more walls exposed to outdoor temperatures), requires the chimney be lined with type “B”, double wall vent or suitable flexible chimney liner material. This applies in all combinations of common venting as well as for fan assisted appliances vented alone.

### WARNING

#### CARBON MONOXIDE POISONING HAZARD

**Failure to follow the installation instructions for the venting system being placed into operation could result in carbon monoxide poisoning or death.**

The following installation practices are recommended to minimize corrosion caused by condensation of flue products in the furnace and flue gas system.

1. Avoid an excessive number of bends.
2. Horizontal runs should pitch upward at least 1/4" per foot.
3. Horizontal runs should be as short as possible.
4. All vent pipe or connectors should be securely supported and must be inserted into, but not beyond the inside wall at the chimney vent.
5. When vent connections must pass through walls or partitions of combustible material, a thimble must be used and installed according to local codes.
6. Vent pipe through the roof should be extended to a height determined by National Fuel Gas Code or local codes. It should be capped properly to prevent rain water from entering the vent. Roof exit should be waterproofed.
7. Use type “B” double wall vent when vent pipe is routed through cool spaces (below 60° F).
8. Where long periods of airflow are desired for comfort, use long fan cycles instead of continuous airflow.
9. Apply other good venting practices as stated in the venting section of the National Fuel Gas Code ANSI Z223.1 “latest edition”. (Reference CATEGORY 1 Venting Guide, Pub. No. 18-CH23D1-2 for additional information).
10. **Vent connectors serving appliance vented by natural draft or non-positive pressure shall not be connected into any portion of a mechanized draft system operating under positive pressure.**
11. Horizontal pipe runs must be supported by hangers, straps or other suitable material in intervals at a minimum of every 3 feet of pipe.
12. A furnace shall not be connected to a chimney or flue serving a separate appliance designed to burn solid fuel.
13. The flow area of the largest section of vertical vent or chimney shall not exceed 7 times the smallest listed appliance categorized vent area, flue collar area, or draft hood outlet area unless designed in accordance with approved engineering methods.

$$\text{Maximum Vent or Tile Lined Chimney Flow Area} = \frac{\pi(D^*)^2}{4} \times 7$$

\*Drafthood outlet diameter, flue collar diameter, or listed appliance categorized vent diameter.

# Operating Instructions

## ⚠ WARNING

### CARBON MONOXIDE POISONING HAZARD

Failure to follow the steps outlined below for each appliance connected to the venting system being placed into operation could result in carbon monoxide poisoning or death.

The following steps shall be followed for each appliance connected to the venting system being placed into operation, while all other appliances connected to the venting system are not in operation:

1. Seal any unused openings in the venting system.
2. Inspect the venting system for proper size and horizontal pitch, as required in the National Fuel Gas Code, ANSI Z223.1/NFPA 54 or the CAN/CGA B149 Installation Codes and these instructions. Determine that there is no blockage or restriction, leakage, corrosion and other deficiencies which could cause an unsafe condition.
3. As far as practical, close all building doors and windows and all doors between the space in which the appliance(s) connected to the venting system are located and other spaces of the building.
4. Close fireplace dampers.
5. Turn on clothes dryers and any appliance not connected to the venting system. Turn on any exhaust fans, such as range hoods and bathroom exhausts, so they are operating at maximum speed. Do not operate a summer exhaust fan.
6. Follow the lighting instructions. Place the appliance being inspected into operation. Adjust the thermostat so appliance is operating continuously.
7. If improper venting is observed during any of the above tests, the venting system must be corrected in accordance with the National Fuel Gas Code, ANSI Z221.1/NFPA 54 and/or CAN/CGA B149 Installation Codes.
8. After it has been determined that each appliance connected to the venting system properly vents where tested as outlined above, return doors, windows, exhaust fans, fireplace dampers and any other gas-fired burning appliance to their previous conditions of use.

TABLE 8

GAS VENT TERMINATION	
ROOF PITCH	MINIMUM HEIGHT
FLAT TO 7/12	1.0 FEET *
OVER 7/12 TO 8/12	1.5 FEET
OVER 8/12 TO 9/12	2.0 FEET
OVER 9/12 TO 10/12	2.5 FEET
OVER 10/12 TO 11/12	3.25 FEET
OVER 11/12 TO 12/12	4.0 FEET
OVER 12/12 TO 14/12	5.0 FEET
OVER 14/12 TO 16/12	6.0 FEET
OVER 16/12 TO 18/12	7.0 FEET
OVER 18/12 TO 20/12	7.5 FEET
OVER 20/12 TO 22/12	8.0 FEET

\* THIS REQUIREMENT COVERS MOST INSTALLATIONS

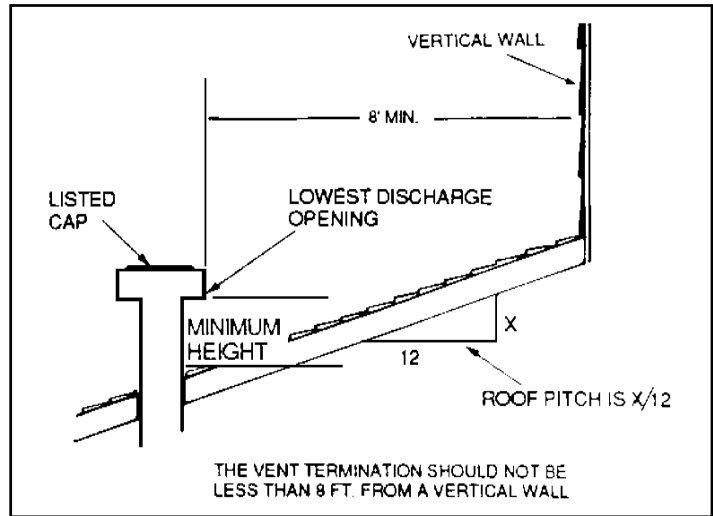

FIGURE 15

## ELECTRICAL CONNECTIONS

### ⚠ WARNING

The cabinet must have an uninterrupted or unbroken ground according to National Electrical Code, ANSI/NFPA 70 - "latest edition" and Canadian Electrical Code, CSA C22.1 or local codes to minimize personal injury if an electrical fault should occur. A failure to follow this warning could result in an electrical shock, fire, injury, or death.

### ⚠ WARNING

To prevent injury or death due to electrical shock or contact with moving parts, lock unit disconnect switch in the open position before servicing the unit. Failure to follow this warning could result in electrical shock, personal injury, or death.

### ⚠ CAUTION

The integrated furnace control is polarity sensitive. The hot leg of the 115 VAC power must be connected to the BLACK factory lead.

Make wiring connections to the unit as indicated on enclosed wiring diagram. As with all gas appliances using electrical power, this furnace shall be connected into a permanently live electric circuit. It is recommended that it be provided with a separate "circuit protection device" electric circuit. The furnace must be electrically grounded in accordance with local codes or in the absence of local codes with the National Electrical Code, ANSI/NFPA 70 "latest edition" or Canadian Electrical Code, CSA C22.1, if an external electrical source is utilized.

All field supplied wiring must conform with the temperature limitation for Type T wire [63° F (35° C)], when installed in accordance with these instructions and wiring diagrams supplied with the furnace. A disconnecting means must be located within sight from, and readily accessible to, the furnace.

Refer to the Maintenance and Service section of the literature for unit wiring diagrams in addition to the diagram inside the blower door.

**FIELD WIRING DIAGRAM FOR 1 STAGE FURNACE  
1 STAGE HEATING  
USING A 1 STAGE HEATING THERMOSTAT  
NO COOLING**

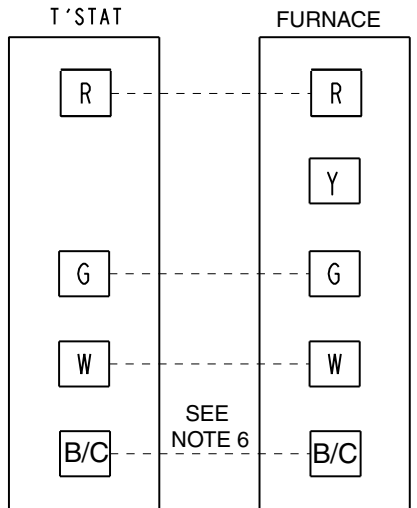

INTER-COMPONENT WIRING

----- 24 V. } FIELD WIRING  
 ----- LINE V. }  
 ----- 24 V. } FACTORY WIRING  
 ----- LINE V. }

NOTES :

1. BE SURE POWER AGREES WITH EQUIPMENT NAMEPLATE(S)
2. LOW VOLTAGE(24 V. WIRING) TO BE NO. 18 A.W.G. MIN.
3. GROUNDING OF EQUIPMENT MUST COMPLY WITH LOCAL CODES.
4. SET THERMOSTAT HEAT ANTICIPATOR PER UNIT WIRING DIAGRAM.
5. IGNITION CONTROL IS POLARITY SENSITIVE. HOT LEG OF 120 VOLT POWER SUPPLY MUST BE CONNECTED TO THE BLACK LINE POWER LEAD AS INDICATED ON THE WIRING DIAGRAM OR IGNITION LOCKOUT WILL OCCUR.
6. THIS CONNECTION IS ONLY USED FOR THERMOSTATS REQUIRING CONNECTION TO THE 24 V. POWER SUPPLY. (COMMON)

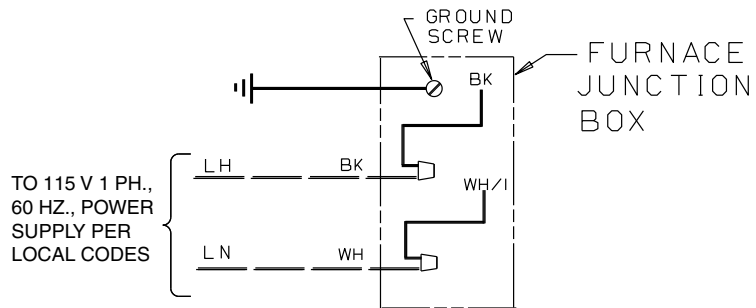

From Dwg. B340433 Rev. 2

**FIELD WIRING DIAGRAM FOR 1 STAGE FURNACE  
1 STAGE HEATING, 1 STAGE COOLING  
USING A 1 STAGE HEATING, 1 STAGE COOLING THERMOSTAT  
(OUTDOOR SECTION WITHOUT TRANSFORMER)**

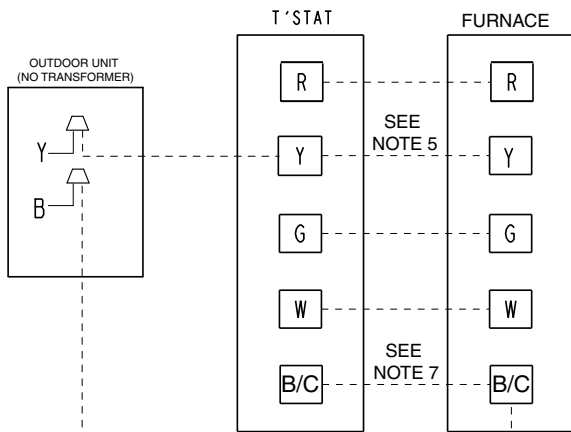

INTER-COMPONENT WIRING

----- 24 V. } FIELD WIRING  
 ----- LINE V. }  
 ----- 24 V. } FACTORY WIRING  
 ----- LINE V. }

NOTES :

1. BE SURE POWER AGREES WITH EQUIPMENT NAMEPLATE(S)
2. LOW VOLTAGE(24 V. WIRING) TO BE NO. 18 A.W.G. MIN.
3. GROUNDING OF EQUIPMENT MUST COMPLY WITH LOCAL CODES.
4. SET THERMOSTAT HEAT ANTICIPATOR PER UNIT WIRING DIAGRAM.
5. THE "Y" TERMINAL FROM THE THERMOSTAT MUST BE WIRED TO THE "Y" TERMINAL OF THE FURNACE CONTROL FOR PROPER BLOWER OPERATION DURING COOLING.
6. IGNITION CONTROL IS POLARITY SENSITIVE. HOT LEG OF 120 VOLT POWER SUPPLY MUST BE CONNECTED TO THE BLACK LINE POWER LEAD AS INDICATED ON THE WIRING DIAGRAM OR IGNITION LOCKOUT WILL OCCUR.
7. THIS CONNECTION IS ONLY USED FOR THERMOSTATS REQUIRING CONNECTION TO THE 24 V. POWER SUPPLY. (COMMON)

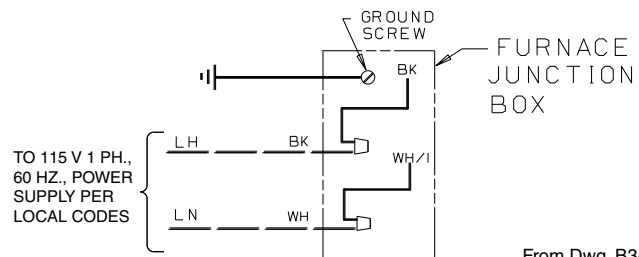

From Dwg. B340432 Rev. 2

# Installation Instructions

## ⚠ WARNING

### FIRE OR EXPLOSION HAZARD

Failure to follow the safety warnings exactly could result in serious injury, death or property damage.

Never test for gas leaks with an open flame. Use a commercially available soap solution made specifically for the detection of leaks to check all connections. A fire or explosion may result causing property damage, personal injury, or loss of life.

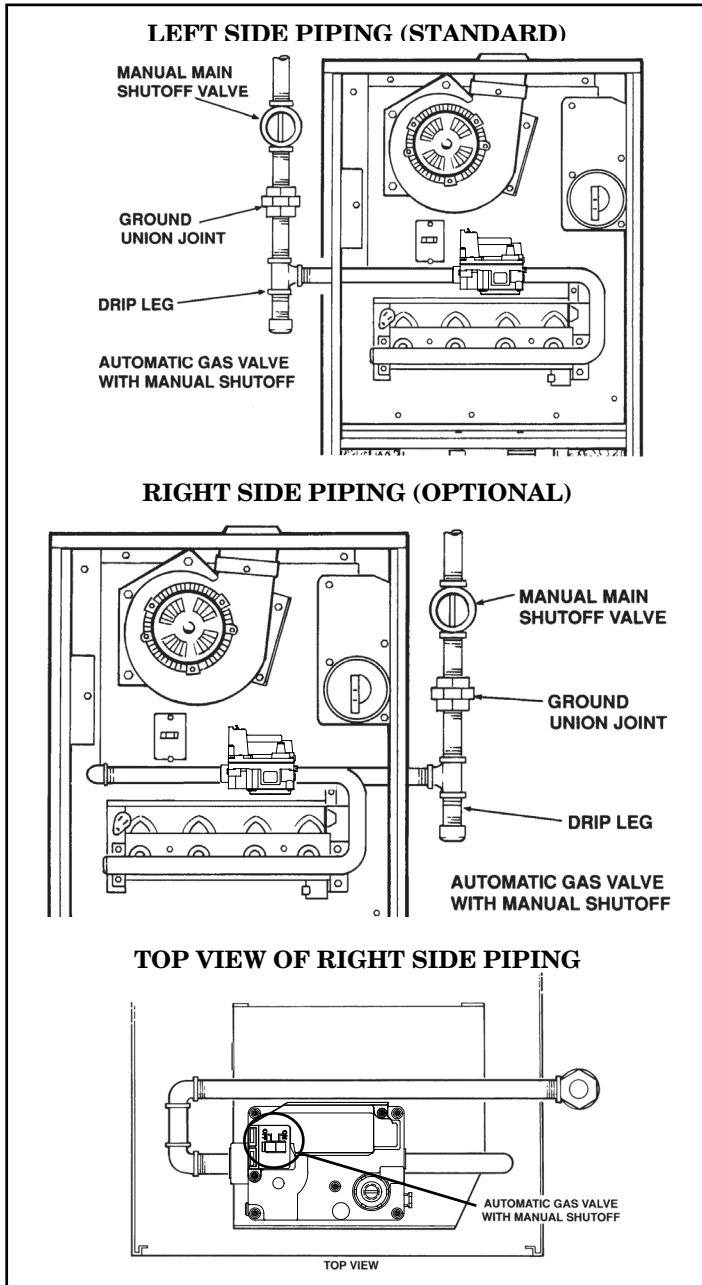

FIGURE 16

## ⚠ WARNING

TO PREVENT AN EXPLOSION OR POSSIBLE INJURY, DEATH AND EQUIPMENT DAMAGE, DO NOT STORE COMBUSTIBLE MATERIALS, GASOLINE OR OTHER FLAMMABLE VAPORS OR LIQUIDS NEAR THE UNIT.

## GAS PIPING

This unit is shipped standard for left side installation of gas piping. A piping knockout is also provided in the right side for an alternate piping arrangement. The installation of piping shall be in accordance with piping codes and the regulations of the local gas company. Pipe joint compound must be resistant to the chemical reaction with liquefied petroleum gases.

Refer to piping Table 9 for delivery sizes. Connect gas supply to the unit, using a ground joint union and a manual shut-off valve as shown in Figure 16. National codes require a condensation drip leg to be installed ahead of the controls as shown in Figure 16.

The furnace and its individual shut-off valve must be disconnected from the gas supply piping system during any pressure testing of that system at test pressures in excess of 1/2 psig.

The furnace must be isolated from the gas supply piping by closing its individual manual shut-off valve during any pressure testing of the gas supply piping system at test pressures equal to or less than 1/2 psig.

## ⚠ CAUTION

Use a backup wrench on the gas valve when installing gas piping to prevent damage to the gas valve and manifold assembly.

### NOTE:

Maximum pressure to the gas valve for natural gas is 13.8" W.C. Minimum pressure is 5.0" W.C. Maximum pressure to the gas valve for propane is 13.8" W.C. Minimum pressure is 11.0" W.C.

All gas fittings must be checked for leaks using a soapy solution before lighting the furnace. **DO NOT CHECK WITH AN OPEN FLAME!**

The following warning complies with State of California law, Proposition 65.

## ⚠ WARNING

### Hazardous Gases!

Exposure to fuel substances or by-products of incomplete fuel combustion is believed by the state of California to cause cancer, birth defects, or other reproductive harm.

## SEQUENCE OF OPERATION

### Thermostat call for heat

R and W thermostat contacts close signaling the control module to run its self-check routine. After the control module has verified that the pressure switch contacts are open and the limit switch(es) contacts are closed, the draft blower will be energized.

As the induced draft blower comes up to speed, the pressure switch contacts will close and the ignitor warm up period will begin. The ignitor will heat for approx. 17 seconds, then the gas valve is energized to permit gas flow to the burners. The flame sensor confirms that ignition has been achieved within the 4 second ignition trial period.

After the flame sensor confirms that ignition has been achieved, the delay fan ON period (fixed at 45 seconds) begins timing. After the delay of 45 seconds, the indoor blower motor will be energized and will continue to run during the heating cycle.

When the thermostat is satisfied, R and W thermostat contacts open, the gas valve will close, the flames will extinguish, and the induced draft blower will be de-energized. The indoor blower motor will continue to run for the fan off period (fixed at 100 seconds), then will be de-energized by the control module.

## START-UP AND ADJUSTMENT PRELIMINARY INSPECTIONS

### With gas and electrical power “OFF”

1. Duct connections are properly sealed
2. Filters are in place
3. Venting is properly assembled
4. Blower door is in place

Turn main gas valve within the unit to the “OFF” position. Turn the external gas shut-off valve to “ON”. Purge the air from the gas lines. After purging, check all gas connections for leaks with a soapy solution — **DO NOT CHECK WITH AN OPEN FLAME.** Allow 5 minutes for any gas that might have escaped to dissipate. LP Gas, being heavier than air, may require forced ventilation. Turn the knob on the gas valve in the unit to the “ON” position.

### COMBUSTION AND INPUT CHECK

1. Make sure all gas appliances are off except the furnace.
2. Clock the gas meter with the furnace operating (determine the dial rating of the meter) for one revolution.
3. Match the “Sec” column in the gas flow (in cfh) Table 12 with the time clocked.
4. Read the “Flow” column opposite the number of seconds clocked.

5. Use the following factors if necessary:

$$\text{For 1 Cu. Ft. Dial Gas Flow CFH} = \frac{\text{Chart Flow Reading}}{2}$$

$$\text{For 1/2 Cu Ft. Dial Gas Flow CFH} = \frac{\text{Chart Flow Reading}}{4}$$

$$\text{For 5 Cu. Ft. Dial Gas Flow CFH} = \frac{10 \times \text{Chart Flow Reading}}{4}$$

6. Multiply the final figure by the heating value of the gas obtained from the utility company and compare to the nameplate rating. This must not exceed the nameplate rating.

### Gas Valve Adjustment

Changes can be made by adjusting the manifold pressure (See Table 9A), or changing orifices (orifice change may not always be required). To adjust the manifold pressure:

1. Turn off all electrical power to the system.
2. Attach a manifold pressure gauge with flexible tubing to the outlet pressure boss marked “OUT P” on White-Rodgers gas valve model 36G or 36J. See Figure 18 for White-Rodgers gas valve model 36J. See Figure 17 for White-Rodgers gas valve model 36G.
3. Loosen (Do Not remove) the pressure tap test set screw one turn with 3/32" hex wrench.
  - a. The pressure tap adjustment kit (KIT07611) contains a 3/32" hex wrench, a 5/16" hose and a connector and can be ordered through Global Parts.
4. Turn on system power and energize valve.
5. Adjust gas heat by removing the adjustment regulator cover screw.
  - a. To increase outlet pressure, turn the regulator adjust screw clockwise.
  - b. To decrease outlet pressure, turn the regulator adjust screw counterclockwise.
  - c. Adjust regulator until pressure shown on manometer matches the pressure specified in Table 9A.

1. The input of no more than nameplate rating and no less than 93% of the nameplate rating, unless the unit is derated for high altitude.

- d. Replace and tighten the regulator cover screw securely.
6. Cycle the valve several times to verify regulator setting.
  - a. Repeat steps 5-6 if needed.
7. Turn off all electrical power to the system.
8. Remove the manometer and flexible tubing and tighten the pressure tap screw.
9. Using a leak detection solution or soap suds, check for leaks at the pressure outlet boss and pressure tap test screw.
10. Turn on system power and check operation of the unit.

## ⚠ CAUTION

**Replace and/or tighten all plugs removed or loosened when adjusting gas pressure. Leak check the fittings before placing the furnace into regular service. Failure to follow this warning could result in fire, explosion, or property damage.**

Table 10 lists the main burner orifices shipped with the furnace. If a change of orifices is required to correct the input rate, refer to Table 11.

**TABLE 9A**

FINAL MANIFOLD PRESSURE SETTINGS (inches w.c.)	
FUEL	PRESSURE
NATURAL GAS	3.5" W.C.
LP GAS	10.5" W.C.

**TABLE 9 NATURAL GAS ONLY**

TABLE OF CUBIC FEET PER HOUR OF GAS FOR VARIOUS PIPE SIZES AND LENGTHS							
PIPE SIZE	LENGTH OF PIPE						
	10	20	30	40	50	60	70
1/2	132	92	73	63	56	50	46
3/4	278	190	152	130	115	105	96
1	520	350	285	245	215	195	180
1-1/4	1050	730	590	520	440	400	370

This table is based on pressure drop of 0.3 inch W.C. and 0.6 SP.GR. gas

**TABLE 10 ORIFICE SIZES**

INPUT RATING BTUH	NUMBER OF BURNERS	MAIN BURNER ORIFICE DRILL SIZE	
		NAT. GAS	LP GAS
40,000	2	45	56
60,000	3	45	56
80,000	4	45	56
100,000	5	45	56
120,000	6	45	56
140,000	7	45	56

**TABLE 11 PART NUMBERS FOR REPLACEMENT ORIFICES**

DRILL SIZE	PART NUMBER	DRILL SIZE	PART NUMBER
44	ORF00501	54	ORF00555
45	ORF00644	55	ORF00693
46	ORF00909	56	ORF00907
47	ORF00910	57	ORF00908
48	ORF01099	58	ORF01338
49	ORF00503	59	ORF01339
50	ORF00493		

# Installation Instructions

## HIGH ALTITUDE DERATE

Input rate changes can be made by adjusting the manifold pressure (min 3.0 - max 3.7 in. W.C. - Natural Gas) or changing orifices (orifice change may not always be required). If the desired input rate cannot be achieved with a change in manifold pressure, then the orifices must be changed. LP installations will require an orifice change.

### IMPORTANT:

Reinstall the propane orifices to the same depth as the orifices supplied with the equipment.

See Table 13 for help in selecting orifices if orifice change is required.

TABLE 12

GAS FLOW IN CUBIC FEET PER HOUR							
2 CUBIC FOOT DIAL							
SEC.	FLOW	SEC.	FLOW	SEC.	FLOW	SEC.	FLOW
8	900	29	248	50	144	82	88
9	800	30	240	51	141	84	86
10	720	31	232	52	138	86	84
11	655	32	225	53	136	88	82
12	600	33	218	54	133	90	80
13	555	34	212	55	131	92	78
14	514	35	206	56	129	94	76
15	480	36	200	57	126	96	75
16	450	37	195	58	124	98	73
17	424	38	189	59	122	100	72
18	400	39	185	60	120	104	69
19	379	40	180	62	116	108	67
20	360	41	176	64	112	112	64
21	343	42	172	66	109	116	62
22	327	43	167	68	106	120	60
23	313	44	164	70	103	124	58
24	300	45	160	72	100	128	56
25	288	46	157	74	97	132	54
26	277	47	153	76	95	136	53
27	267	48	150	78	92	140	51
28	257	49	147	80	90	144	50

TABLE 13

Orifice Twist Drill Size If Installed At Sea Level	ALTITUDE ABOVE SEA LEVEL and Orifice Required At Other Elevations									
	2000	3000	4000	5000	6000	7000	8000	9000	10000	
42	42	43	43	43	44	44	45	46	47	
43	44	44	44	45	45	46	47	47	48	
44	45	45	45	46	47	47	48	48	50	
45	46	47	47	47	48	48	49	49	50	
46	47	47	47	48	48	49	49	50	51	
47	48	48	49	49	49	50	50	51	52	
54	54	55	55	55	55	55	56	56	56	
55	55	55	55	56	56	56	56	56	57	
56	56	56	57	57	57	58	59	59	60	
57	58	59	59	60	60	61	62	63	63	
58	59	60	60	61	62	62	63	63	64	

From National Fuel Gas Code - Table F-4

Furnace input rate and temperature rise should be checked again after changing orifices to confirm the proper rate for the altitude.

Installations above 4,000 feet may require a pressure switch change. If required, use the BAYHALT\*\*\* Kit (High Altitude Accessory Kit) listed in PRODUCT DATA.

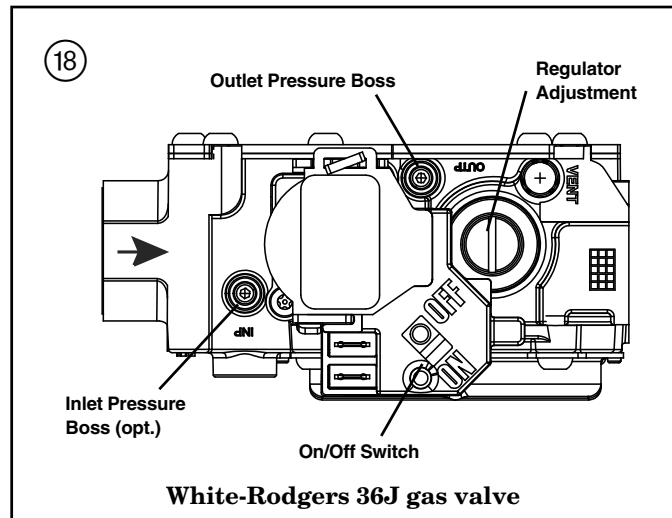
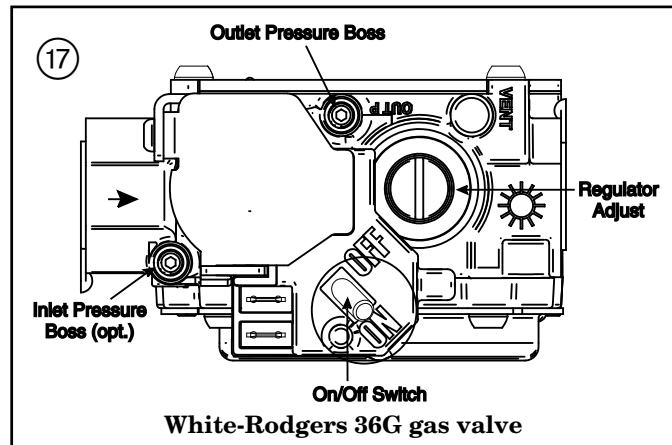

## LIGHTING INSTRUCTIONS

### ⚠ WARNING

**DO NOT** attempt to manually light the burner. Failure to follow this warning could result in property damage, personal injury or death.

Lighting instructions appear on each unit. Each installation must be checked out at the time of initial start up to insure proper operation of all components. Check out should include putting the unit through one complete cycle as outlined below.

Turn on the main electrical supply and set the thermostat above the indicated temperature. The ignitor will automatically heat, then the gas valve is energized to permit the flow of gas to the burners. After ignition and flame is established, the flame control module monitors the flame and supplies power to the gas valve until the thermostat is satisfied.

### TO SHUT OFF

For complete shutdown: Move the control switch on the main gas valve to the "OFF" position (See Figure 17 & 18). Disconnect the electrical supply to the unit.



## CAUTION

If this is done during the cold weather months, provisions must be taken to prevent freeze-up of all water pipes and water receptacles. Failure to follow this warning could result in property damage.

Whenever your house is to be vacant, arrange to have someone inspect your house for proper temperature. This is very important in below freezing weather. If for any reason your furnace should fail to operate damage could result, such as frozen water pipes.

### CONTROL AND SAFETY SWITCH ADJUSTMENT

#### LIMIT SWITCH CHECK OUT

The limit switch is a safety device designed to close the gas valve should the furnace become overheated. Since proper operation of this switch is important to the safety of the unit, it **must be checked out on initial start up by the installer.**

To check for proper operation of the limit switches, set the thermostat to a temperature higher than the indicated temperature to bring on the gas valve. Restrict the airflow by blocking the return air or by disconnecting the blower. When the furnace reaches the maximum outlet temperature as shown on the rating plate, the burners must shut off. If they do not shut off after a reasonable time and overheating is evident, a faulty limit switch is probable and the limit switch must be replaced. After checking the operation of the limit control, be sure to remove the paper or cardboard from the return air inlet, or reconnect the blower.

#### AIRFLOW ADJUSTMENT

Check inlet and outlet air temperatures to make sure they are within the ranges specified on the furnace rating nameplate. If the airflow needs to be increased or decreased, see the wiring diagram for information on changing the speed of the blower motor.

## WARNING

**Disconnect power to the unit before removing the blower door. Failure to follow this warning could result in property damage, personal injury or death.**

This unit is equipped with a blower door switch which cuts power to the blower and gas valve causing shutdown when the door is removed. Operation with the door removed or ajar can permit the escape of dangerous fumes. All panels must be securely closed at all times for safe operation of the furnace.

#### NOTE:

**Direct drive motors have bearings which are permanently lubricated and under normal use, lubrication is not recommended.**

#### INDOOR BLOWER TIMING

The control module controls the indoor blower. The blower starts approximately 45 seconds after ignition. The FAN-OFF period is approximately 100 seconds from the interruption of gas flow.

#### ROOM AIR THERMOSTAT HEAT ANTICIPATOR ADJUSTMENT

Set the thermostat heat anticipator according to the current flow measured, or the settings found in the notes on the furnace wiring diagram (found inside the furnace casing).

The following warning complies with State of California law, Proposition 65.

## WARNING

**This product contains fiberglass wool insulation!**

Fiberglass dust and ceramic fibers are believed by the State of California to cause cancer through inhalation. Glasswool fibers may also cause respiratory, skin, or eye irritation.

### PRECAUTIONARY MEASURES

- Avoid breathing fiberglass dust.
- Use a NIOSH approved dust/mist respirator.
- Avoid contact with the skin or eyes. Wear long-sleeved, loose-fitting clothing, gloves, and eye protection.
- Wash clothes separately from other clothing: rinse washer thoroughly.
- Operations such as sawing, blowing, tear-out, and spraying may generate fiber concentrations requiring additional respiratory protection. Use the appropriate NIOSH approved respirator in these situations.

### FIRST AID MEASURES

**Eye Contact** – Flush eyes with water to remove dust. If symptoms persist, seek medical attention.

**Skin Contact** – Wash affected areas gently with soap and warm water after handling.

### INSTRUCTIONS TO THE OWNERS

**In the event that electrical, fuel, or mechanical failures occur, the owner should immediately turn the gas supply off at the manual gas valve, located in the burner compartment (See Figure 16). Also turn off electrical power to the furnace and contact the service agency designated by your dealer.**

## WARNING

**Should overheating occur, or the gas supply fail to shut off, shut the gas valve to the unit before shutting off the electrical supply. Failure to follow this warning could result in property damage, personal injury, or death.**

## WARNING

### FIRE OR EXPLOSION HAZARD

**Failure to follow the safety warnings exactly could result in serious injury, death or property damage.**

**Never test for gas leaks with an open flame. Use a commercially available soap solution made specifically for the detection of leaks to check all connections. A fire or explosion may result causing property damage, personal injury, or loss of life.**

# User's Information Guide

## Upflow Only and Downflow / Horizontal, Gas-Fired Furnaces "Fan Assisted Combustion System"

**Contents:**

Dangers, Warnings & Cautions .....	18
General Information .....	18-19
To Start The Furnace .....	19-20
Proper Maintenance .....	21-22
The Problem Solver .....	23
Regular Dealer Maintenance .....	24
Warranty .....	39-40

### GENERAL INFORMATION

Understand the signal words **DANGER, WARNING, AND CAUTION**. These words are safety alert words. **DANGER** indicates the most serious hazards which **will** result in severe personal injury or death. **WARNING** indicates hazards which **could** result in personal injury or death. **CAUTION** is used to indicate unsafe practices which could result in minor injury or property damage.

### IMPORTANT FACTS

The flow of combustion and ventilating air must not be obstructed from reaching the furnace. Air openings provided in the casing of the furnace must be kept free of obstructions which would restrict airflow, thereby affecting efficiency and safe operation of your furnace.

Also, air openings provided to the area in which the furnace is installed and the space around the furnace shall not be blocked or obstructed. Keep this in mind should you choose to remodel the area which contains your furnace. If additional insulation is added after the furnace is installed, the area around the furnace must be inspected to ensure it is free and clear of insulation. If this furnace is installed in an attic or other insulated space it must be kept free and clear of all insulating materials as some insulating materials are combustible.

Furnaces must have air for proper performance. There must be a free flow of fresh air sufficient for efficient combustion and safe ventilation of your furnace.

The combustion air for your furnace must be fresh uncontaminated air. Paints, varnishes, laundry bleaches, detergents, many household cleaners, water softening salts, adhesives, and all such products release fumes containing compounds which could lead to early heat exchanger and vent system deterioration. Do not store these types of products near your furnace.

### Never store gasoline, combustible materials, or other flammable liquids or vapors near your furnace.

Carbon monoxide, fire or smoke can cause serious bodily injury, death, and/or property damage.

A variety of potential sources of carbon monoxide can be found in a building or dwelling such as gas-fired clothes dryers, gas cooking stoves, water heaters, furnaces and fireplaces. The U.S. Consumer Product Safety Commission recommends that users of gas-burning appliances install carbon monoxide detectors as well as fire and smoke detectors per the manufacturer's installation instructions to help alert dwelling occupants of the presence of fire, smoke or unsafe levels of carbon monoxide. These devices should be listed by Underwriters Laboratories, Inc. *Standards for Single and Multiple Station Carbon Monoxide Alarms, UL 2034* or CSA International Standard, *Residential Carbon Monoxide Alarming Devices, CSA 6.19*

### **WARNING**

If the information in this manual is not followed exactly, a fire or explosion may result causing property damage, personal injury or loss of life.

- Do not store or use gasoline or other flammable vapors and liquids in the vicinity of this or any other appliance.
- **WHAT TO DO IF YOU SMELL GAS**
  - Do not try to light any appliance.
  - Do not touch any electrical switch; do not use any phone in your building.
  - Immediately call your gas supplier from a neighbor's phone. Follow the gas supplier's instructions.
  - If you cannot reach your gas supplier, call the fire department.
- **DO NOT RELY ON SMELL ALONE TO DETECT LEAKS. DUE TO VARIOUS FACTORS, YOU MAY NOT BE ABLE TO SMELL FUEL GASES.**
  - U.L. recognized fuel gas and CO detectors are recommended in all applications, and their installation should be in accordance with the manufacturer's recommendations and/or local laws, rules, regulations, or customs.
- Installation and service must be performed by a qualified installer, service agency or the gas supplier.

### **WARNING**

**DO NOT USE THIS UNIT IF ANY PART HAS BEEN UNDER WATER. IMMEDIATELY CALL A QUALIFIED SERVICE TECHNICIAN TO INSPECT THE FURNACE AND REPLACE ANY PART OF THE CONTROL SYSTEM AND ANY GAS CONTROL WHICH HAS BEEN UNDER WATER.**

**NOTE:**

The manufacturer of your furnace does not test any detectors and makes no representations regarding any brand or type of detector.

**⚠ WARNING**

**BODILY INJURY CAN RESULT FROM HIGH VOLTAGE ELECTRICAL COMPONENTS, FAST MOVING FANS, AND COMBUSTIBLE GAS. FOR PROTECTION FROM THESE INHERENT HAZARDS DURING INSTALLATION AND SERVICING, THE ELECTRICAL SUPPLY MUST BE TURNED OFF.**

Installing and servicing heating equipment can be hazardous due to gas and electrical components. Only trained and qualified personnel should install, repair or service heating equipment.

Untrained personnel can perform basic maintenance functions such as cleaning and replacing filters. All other operations must be performed by trained service personnel.

Parts and controls of this furnace are unique. Should service or modification be required, be sure your servicer uses only factory authorized parts, kits, or accessories for this furnace.

If you experience a problem with the operation of your furnace, check the "Problem Solver" section of this manual before you call for a possibly unneeded service call.

**⚠ WARNING**

**Improper installation, adjustment, alteration, service or maintenance can cause injury or property damage. Refer to the installation instructions provided with the furnace and this manual. For assistance or additional information consult a qualified installer, service agency or the gas supplier.**

## To start the furnace.

### Lighting instructions.

Your furnace does not use a continuously burning pilot flame. Therefore, manually lighting your furnace is not required. Your furnace is equipped with an automatic ignition system. It uses a hot surface ignition device that automatically lights the burners each time the thermostat signals the furnace to start.

**⚠ WARNING**

**Do not attempt to manually light the furnace.**

1. Please read all safety information in this book before operating furnace.
2. Set thermostat to lowest setting. Turn off all electric power to furnace.
3. Remove the furnace front panel to gain access to the main gas valve.
4. Turn gas cock knob clockwise or the toggle switch located on the main gas valve inside the unit to "OFF" position (see illustration on this page). If external gas cock is used, turn to "OFF" position (see illustration on next page). Allow 5 minutes for any gas within the unit to escape. LP gas being heavier than air may require forced ventilation. If you smell gas STOP! Follow the "What To Do If You Smell Gas" instructions on the front cover of this book. If you don't smell gas, go to next step.
5. Turn gas cock knob counterclockwise or the toggle switch to "ON" marker (see illustration on this page).
6. Replace the furnace front access panel.

7. Turn on main electrical supply and set thermostat to desired setting. Combustion blower will start and ignition device will start to heat up. After approximately 15 seconds main gas valve will open and burners will ignite.

8. When thermostat is satisfied, main burners will extinguish.

9. If main burners fail to ignite, lower thermostat setting or disconnect electrical supply, wait 5 minutes, raise thermostat setting above indicated temperature.

10. If furnace will not light, turn "OFF" all gas and electricity to unit and call servicer or gas supplier.

**For complete shutdown.**

Turn gas cock knob on main gas valve to "OFF" position. Disconnect electrical supply to unit.

**⚠ CAUTION**

**If this is done during the cold weather months, provisions must be taken to prevent freeze-up of all water pipes and water receptacles.**

Whenever your house is to be vacant, arrange to have someone inspect your house for proper temperature. If your furnace should fail to operate, damage could result, such as frozen water pipes.

**Flame Roll-out Device.**

All models are equipped with a fusible link located near the burners. In case of flame roll-out, the link will open (melt) and cause the circuit to open which shuts off all flow of gas.

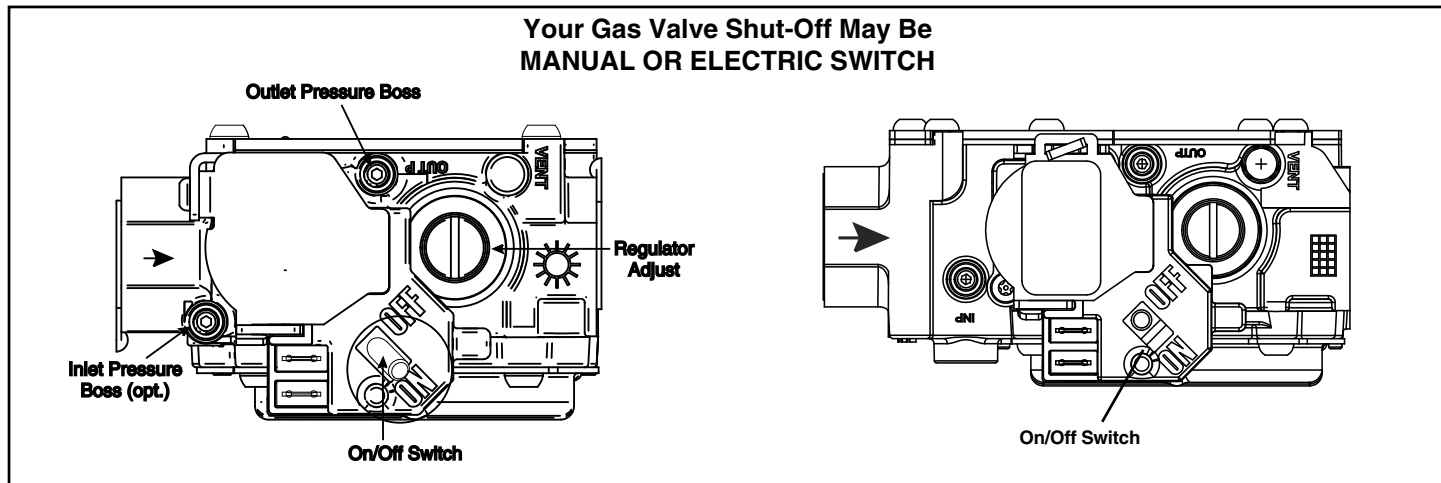

# Operating Instructions

**NOTE THE LOCATION OF THE MANUAL MAIN GAS SHUT-OFF VALVE FOR YOUR FURNACE.**

Have your installer or servicer show you the location if you have any questions.

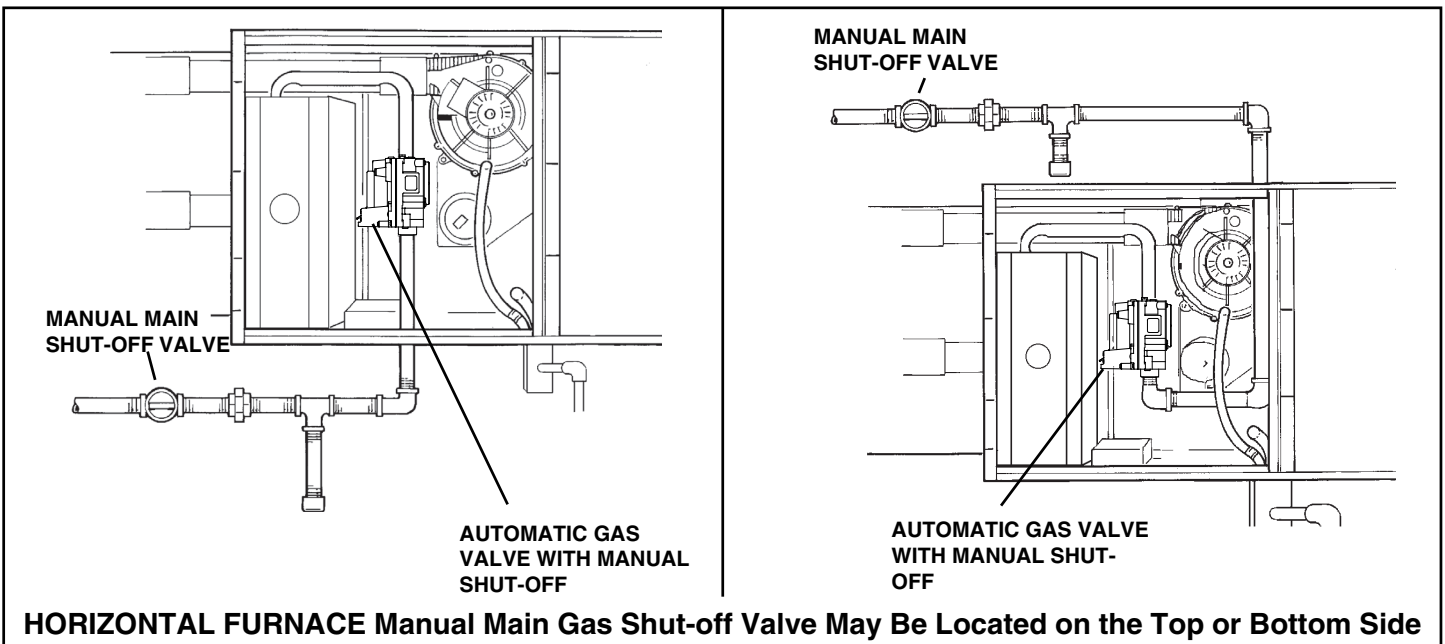
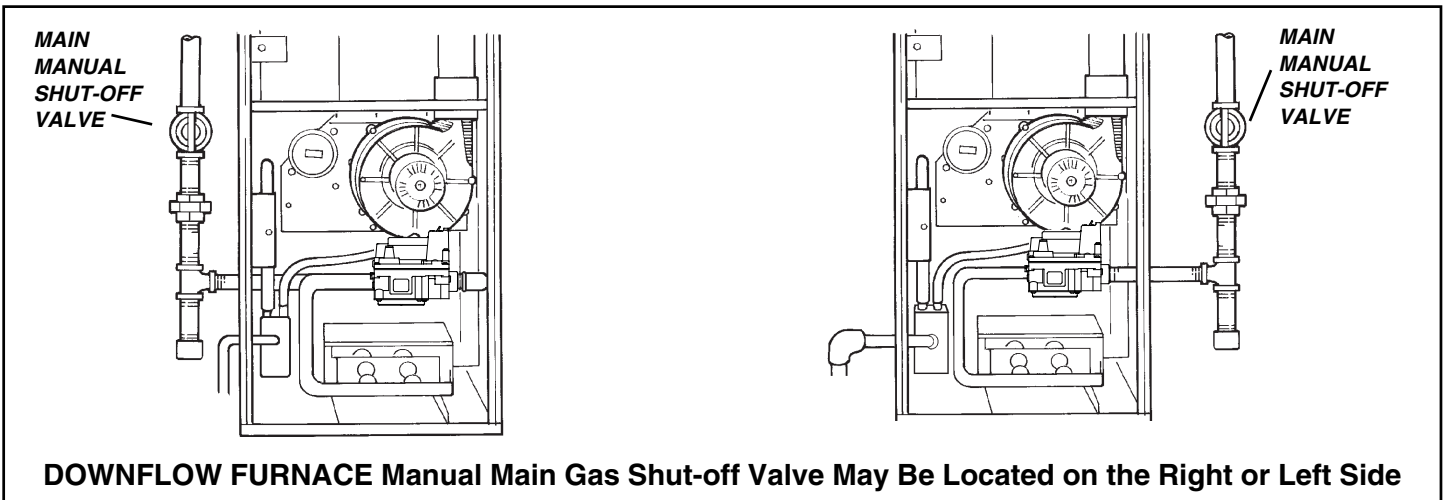
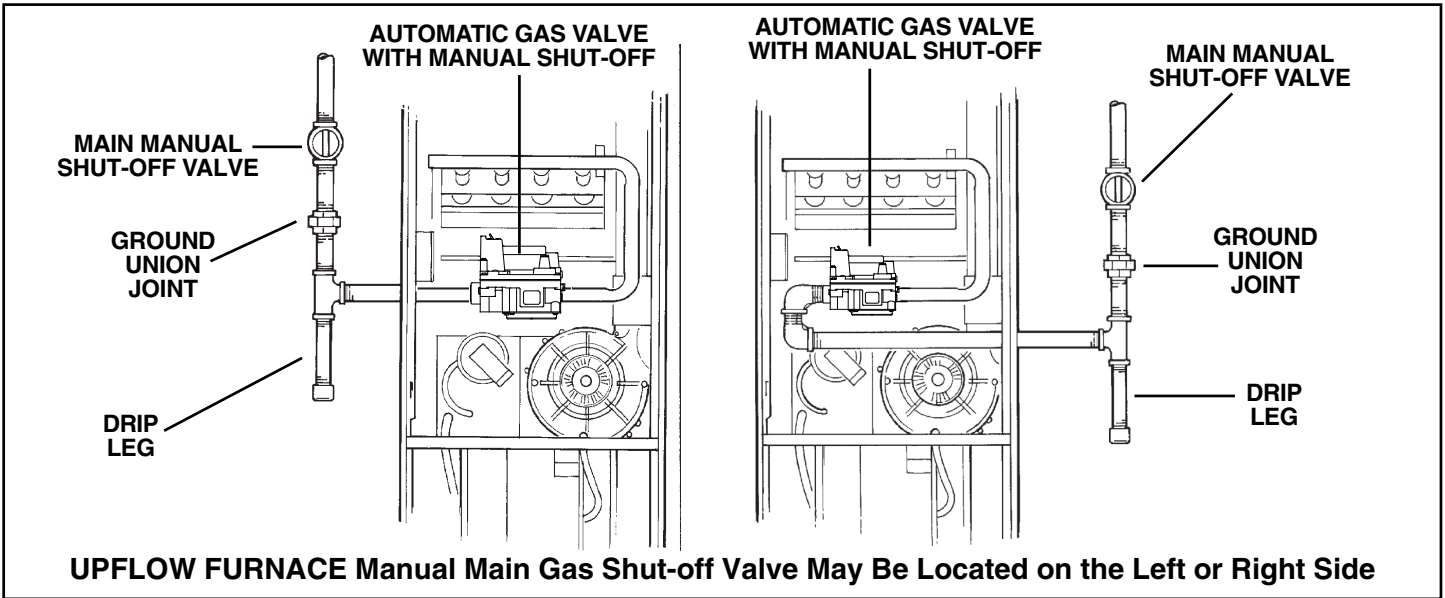

## Proper maintenance reduces energy use.

### A clean filter saves money.

When the furnace circulates and filters the air in your home, dust and dirt particles build up on the filter. Excessive accumulation can block the airflow, forcing the unit to work harder to maintain desired temperatures.

And the harder your unit has to work, the more energy it uses. So you pay more any time your system is running with a dirty filter.

### ⚠ CAUTION

**Never operate your unit for either heating or cooling with filters removed.**

Help ensure top efficiency by cleaning the filter once a month. Clean it twice a month during seasons when the unit runs more often.

You can clean the filter with a vacuum, OR you can wash it with a household detergent.

Both methods are quick and easy, and guaranteed to improve the performance of your system.

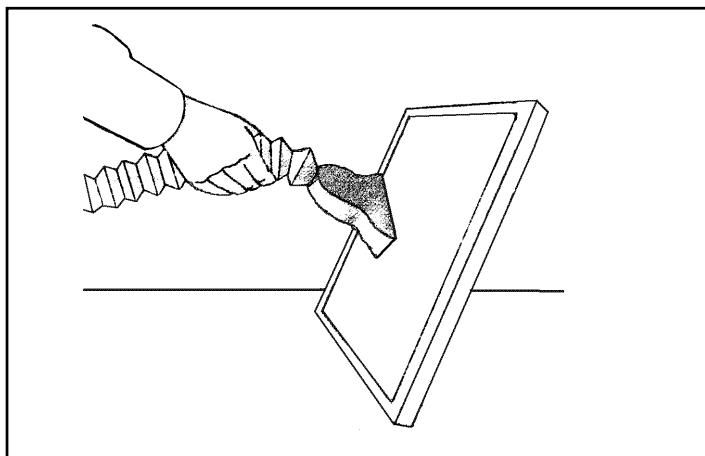

Your filter may or may not be framed.

### Replacing your filter.

When replacing your furnace filters, always use high velocity type which are the same size as originally supplied. Filters are available from your dealer.

Where disposable filters are used, they must be a high velocity type which are the same size as originally supplied.

### How to remove your filter.

### ⚠ WARNING

**Disconnect power to unit before removing blower door.**

Upflow furnaces use a high velocity type air filter which may be located within the furnace blower compartment in either a BOTTOM or SIDE (left or right) return air inlet. The furnace may be secured with filter retaining brackets (as shown) or a filter retainer wire.

To replace filters, remove blower access door, push back to flex the filter and clear the filter retaining bracket at the front of the unit. After cleaning, replace the filter in the same manner making sure that the filter wire is secured in place in both front and back filter retaining brackets. Replace blower access door.

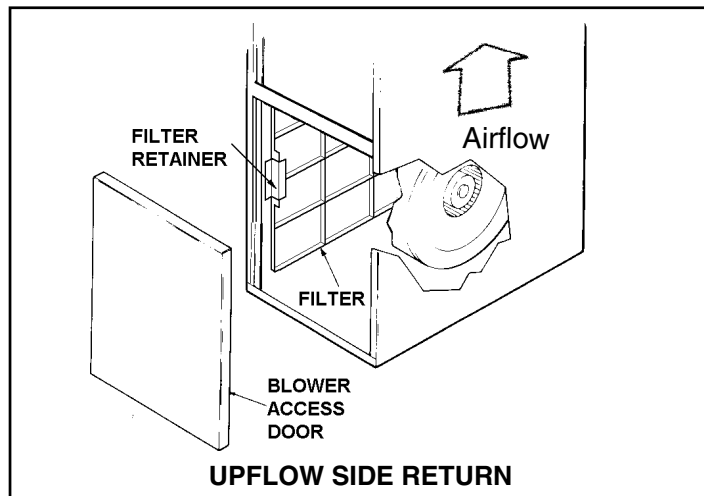
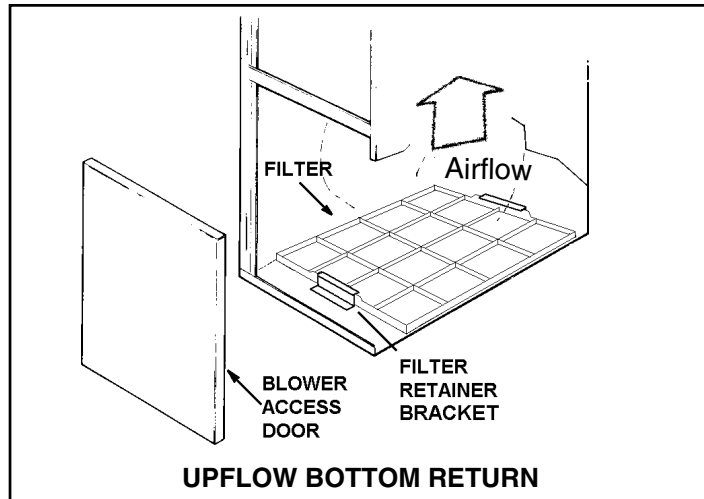

A bottom return air inlet as shown features a 17" x 25" x 1" filter in the 17-1/2" wide furnace cabinets; a 20" x 25" x 1" filter in the 21" wide models; and a 24" x 25" x 1" filter in the 24-1/2" wide cabinet.

For vertical UPFLOW ONLY, a left or right return air inlet as above (left side shown) requires trimming of the factory supplied filter to 17" x 25" x 1" for both the 21" and 24-1/2" wide furnaces.

Air filters may also be located outside of the furnace using a **SIDE FILTER FRAME**.

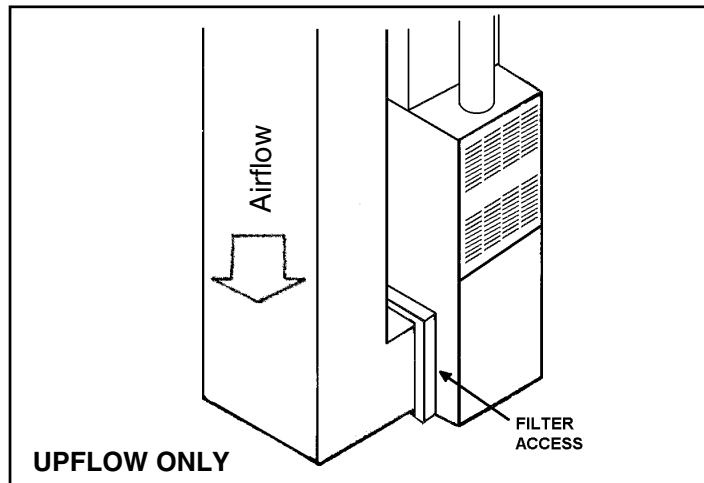

# Operating Instructions

## Upflow/Horizontal Furnace Filters

The Upflow/Horizontal furnace when installed horizontally requires a horizontal filter kit. The filters may be located remote to the furnace or in the return air duct near the furnace. Check with your dealer for the location of your filters.

An upflow/horizontal furnace in horizontal return air filter application, as shown, features two 16" x 20" x 1" filters in the 17-1/2", 21" and 24-1/2" wide furnace cabinets.

To replace filters, remove the filter access door, lift the filter from the lower bracket and shift the filter to the side to free the top filter from the bracket and slide the filters out through the filter access door. After cleaning, replace the filters in the same manner making sure that the filters are secured in place in both top and bottom filter brackets. Replace filter access door.

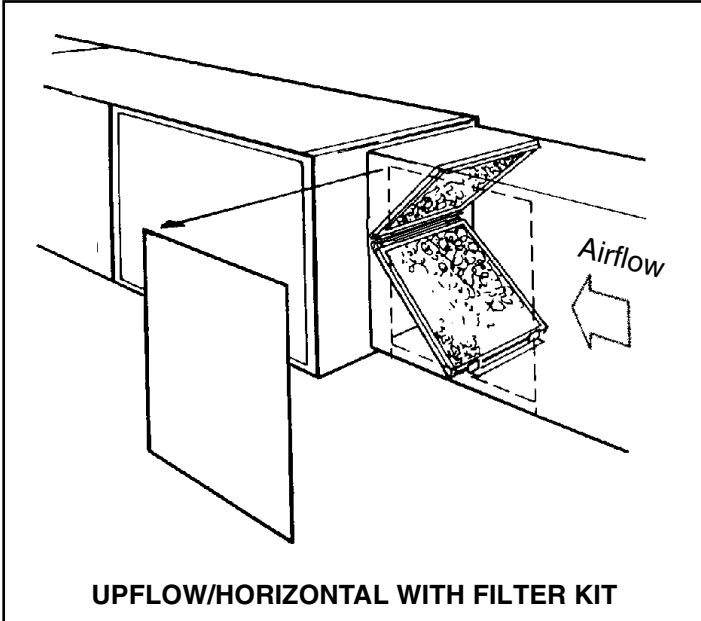

Air filters may also be located outside of the furnace using a remote filter grille. The filter grille could be in a hallway, wall, or in the ceiling. Check with your dealer for the exact location of your filter and the method of changing the filters.

### UPFLOW (Vertical) FILTER TABLES

REQUIRED FILTERS - BOTTOM	
CABINET WIDTH	FILTER QUANTITY & SIZE
17-1/2"	1 - 17" X 25" X 1"
21"	1 - 20" X 25" X 1"
24-1/2"	1 - 24" X 25" X 1"

REQUIRED FILTERS - SIDE **	
CABINET WIDTH	FILTER QUANTITY & SIZE
17-1/2"	1 - 17" X 25" X 1"
21"	1 - 20" X 25" X 1"
24-1/2"	1 - 24" X 25" X 1"

\*\* ON UPFLOW 5 TON AIRFLOW MODELS, IF THE AIRFLOW REQUIREMENT EXCEEDS 1800 CFM, THESE MODELS WILL REQUIRE FILTERS ON BOTH SIDES **OR** 1 SIDE AND THE BOTTOM, **OR** JUST THE BOTTOM

Downflow/Horizontal furnaces are factory supplied with 2 standard size permanent type air filters which may be located remote to the furnace or in the return air duct. Check with your dealer for the location of your filters.

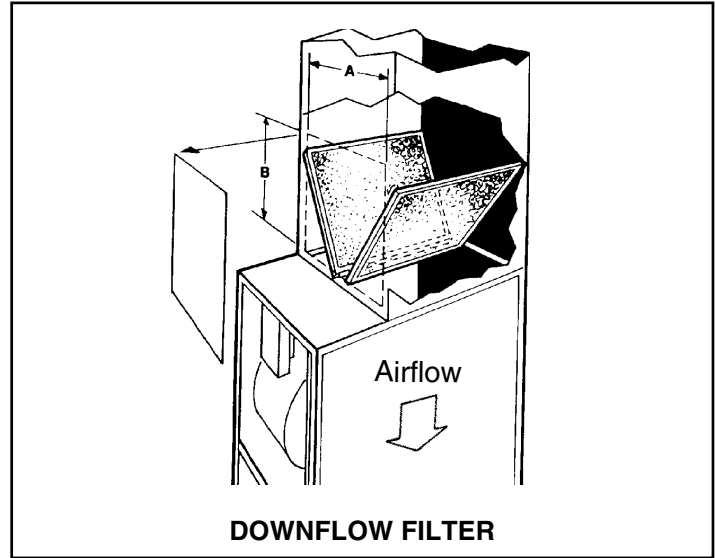

A downflow/horizontal furnace return air filter application, as shown, features two 14" x 20" x 1" filter in the 17-1/2" wide furnace cabinets; or two 16" x 20" x 1" filter in the 21" and 24-1/2" wide furnace cabinets.

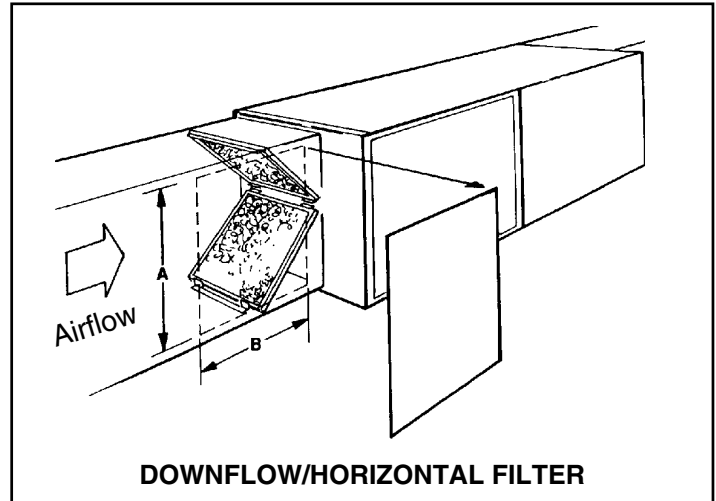

### DOWNFLOW (Vertical) FILTER TABLE

REQUIRED FILTERS - SIDE **	
CABINET WIDTH	FILTER QUANTITY & SIZE
17-1/2"	1 - 17" X 25" X 1"
21"	1 - 20" X 25" X 1"
24-1/2"	1 - 24" X 25" X 1"

\*\* ON UPFLOW 5 TON AIRFLOW MODELS, IF THE AIRFLOW REQUIREMENT EXCEEDS 1800 CFM, THESE MODELS WILL REQUIRE FILTERS ON BOTH SIDES **OR** 1 SIDE AND THE BOTTOM, **OR** JUST THE BOTTOM

## The problem solver.

A furnace is not a household appliance. It is complex and requires professional maintenance and repair.

That's why attempts at "do-it-yourself" repairs on an in-warranty unit may void the remainder of your warranty.

Other than performing the simple maintenance recommended in this manual, you should not attempt to make any adjustments to your furnace. Your dealer will be able to take care of any questions

or problems you may have. A periodic inspection of your furnace should be made by a qualified service agency at the start of each heating season.

### Keep your furnace looking like new for years.

Clean the enamel finish of your furnace with ordinary soap and water. For stubborn grease spots, use a household detergent. Lacquer thinner or other synthetic solvents may damage the finish.

### Save time and money. Before calling for service, check the following:

Problem	Possible Trouble	Possible Remedy
No Heating - Blower Does not operate	<ol style="list-style-type: none"> <li>1. Thermostat set incorrectly.</li> <li>2. Blown fuse or tripped circuit breaker.</li> <li>3. Defective component.</li> <li>4. Burner does not ignite.</li> <li>5. Main gas line turned off.</li> <li>6. Blower door removed or ajar.</li> <li>7. Lockout</li> </ol>	<ol style="list-style-type: none"> <li>1. Adjust thermostat. See operating instructions</li> <li>2. Replace or reset protective device or call for servicer.</li> <li>3. Most controls are automatic and will recycle. If your unit still does not operate call for servicer.</li> <li>4. Call servicer.</li> <li>5. Have gas company check.</li> <li>6. Close door securely to restore power to blower and gas valve.</li> <li>7. Turn power on-off-on-off twice in 30 seconds.</li> </ol>
Insufficient Heating - Blower operates continuously	<ol style="list-style-type: none"> <li>1. Dirty air filters.</li> <li>2. Blocked supply or return registers.</li> </ol>	<ol style="list-style-type: none"> <li>1. Clean or replace filters.</li> <li>2. Make sure registers are open and No obstacles blocking off the air.</li> </ol>
No Heat - Vent motor is running	Restricted or plugged furnace condensate drain.	<ol style="list-style-type: none"> <li>1. Remove drain clamps to condensate trap and drain pan outlet</li> <li>2. Flush or clean drain blockage.</li> <li>3. Reinstall clamps.</li> </ol>
<b>Unusual Noise</b>		Call your servicer

The following warning complies with State of California law, Proposition 65.

## **WARNING**

### **THIS PRODUCT CONTAINS FIBERGLASS WOOL INSULATION!**

**Fiberglass dust and ceramic fibers are believed by the State of California to cause cancer through inhalation. Glasswool fibers may also cause respiratory, skin, or eye irritation.**

#### **PRECAUTIONARY MEASURES**

- Avoid breathing fiberglass dust.
- Use a NIOSH approved dust/mist respirator.
- Avoid contact with the skin or eyes. Wear long-sleeved, loose-fitting clothing, gloves, and eye protection.
- Wash clothes separately from other clothing: rinse washer thoroughly.
- Operations such as sawing, blowing, tear-out, and spraying may generate fiber concentrations requiring additional respiratory protection. Use the appropriate NIOSH approved respirator in these situations.

#### **FIRST AID MEASURES**

- Eye Contact** – Flush eyes with water to remove dust. If symptoms persist, seek medical attention.
- Skin Contact** – Wash affected areas gently with soap and warm water after handling.

## **WARNING**

### **CARBON MONOXIDE POISONING HAZARD**

**Failure to follow the installation and operation instructions for the venting system's operation could result in carbon monoxide poisoning or death.**

## Regular dealer maintenance.

**Never stop the cooling system by shutting off the main power.**

If the main power to your air conditioner is ever disconnected for more than three hours, turn off the thermostat. Then wait for at least three more hours after the power has been restored before turning the thermostat back on. Failure to follow this procedure could result in damage to your air conditioning system.

1. **GENERAL INSPECTION** — Examine the furnace installation for the following items:

- All flue product carrying areas external to the furnace (i.e. chimney, vent connector) are clear and free of obstruction.
- The vent connector is in place, slopes upward and is physically sound without holes or excessive corrosion.
- The return air duct connection(s) is physically sound, is sealed to the furnace and terminates outside the space containing the furnace.
- The physical support of the furnace should be sound without sagging, cracks, gaps, etc., around the base so as to provide a seal between the support and the base.
- There are no obvious signs of deterioration of the furnace.

The following warning complies with State of California law, Proposition 65.

### **⚠ WARNING**

#### **Hazardous Gases!**

**Exposure to fuel substances or by-products of incomplete fuel combustion is believed by the state of California to cause cancer, birth defects, or other reproductive harm.**

2. **BLOWERS** — The blower size and speed determine the air volume delivered by the furnace. The blower motor bearings are factory lubricated and under normal operating conditions usually do not require servicing. Annual cleaning of the blower wheel and housing is recommended for maximum air output, and this must be performed only by a qualified servicer or service agency.

### **⚠ WARNING**

**Unit is equipped with a blower door switch which cuts power to blower and gas valve causing shutdown when door is removed. Unit must not be altered to allow operation with the blower door removed. Operation with doors removed or ajar can permit the escape of dangerous fumes. All panels must be securely closed at all times for safe operation of the furnace.**

3. **IGNITER** — This unit has a special hot surface direct ignition device that automatically lights the burners. Please note that it is very fragile and should be handled with care.

### **⚠ CAUTION**

**Do not touch igniter. It is extremely hot.**

4. **BURNER** — Gas burners do not normally require scheduled servicing, however, accumulation of foreign material may cause a yellowing flame or delayed ignition. Either condition indicates that a service call is required. For best operation, burners must be cleaned annually using brushes and vacuum cleaner.

Turn off gas and electric power supply. To clean burners, remove top burner bracket and lift burner from orifice.

#### **NOTE:**

**Be careful not to break igniter when removing burners.**

Clean burners with brush and/or vacuum cleaner. Reassemble parts by reversal of the above procedure.

#### **NOTE:**

**On LP (propane) units, some light yellow tipping of the outer mantle is normal. Inner mantle should be bright blue.**

Natural gas units should not have any yellow tipped flames. This condition indicates that a service call is required. For best operation, burners must be cleaned annually using brushes and vacuum cleaner.

#### **NOTE:**

**On LP (propane) units, due to variations in BTU content and altitude, servicing may be required at shorter intervals.**

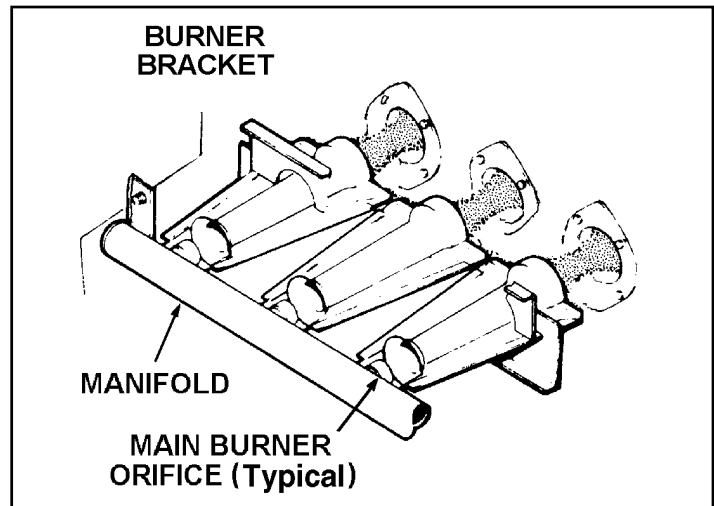

5. **HEAT EXCHANGER / FLUE PIPE** — These items must be inspected for signs of corrosion, and/or deterioration at the beginning of each heating season by a qualified service technician and cleaned annually for best operation.

6. **CIRCUIT PROTECTION** — If blower or gas valve fail to operate, the cause could be the circuit breaker or a loose or blown fuse. Replace fuse or reset circuit breaker.

7. **OPERATION** — Your warm air furnace should not be operated in a corrosive atmosphere. Paint solvents, cleaning chemicals, spray propellants, and bleaches should not be used in the vicinity of the furnace during normal operation.

8. **COOLING COIL CONDENSATE DRAIN** — If you have a cooling coil installed with your furnace, condensate drains should be checked and cleaned periodically to assure that condensate can drain freely from coil to drain. If condensate cannot drain freely water damage could occur.

9. **AIR CIRCULATION** — To ensure increased comfort, the blower on this unit may be operated continuously for both heating and cooling. This will result in constantly filtered air and aid in maintaining more even temperatures by avoiding temperature stratification throughout the conditioned area. To accomplish constant air circulation, set your thermostat fan switch to "ON".

### **⚠ WARNING**

**Should overheating occur, or the gas supply fail to shut off, shut off the manual gas valve to the furnace before shutting off the electrical supply.**

In the event that electrical, fuel or mechanical failures occur, the owner should immediately turn off the gas supply at the manual gas valve located in the burner compartment and electrical power to the furnace and contact servicer.



# MAINTENANCE AND SERVICE INFORMATION

**⚠ WARNING DISCONNECT POWER BEFORE SERVICING**

## PRODUCT SPECIFICATIONS ①

MODEL	CUB1A040A9241A	CUB1A060A9361A	CUB1B060A9361A	CUB1B080A9361A
<b>TYPE</b>	Upflow	Upflow	Upflow	Upflow
<b>RATINGS ②</b>				
Input BTUH ③	40,000	60,000	60,000	80,000
Capacity BTUH (ICS) ③	31,000	47,000	47,000	63,000
Temp. rise (Min.-Max.) °F.	30 - 60	30 - 60	30 - 60	30 - 60
AFUE	80.0	80.0	80.0	80.0
<b>BLOWER DRIVE</b>	Direct	Direct	Direct	Direct
Diameter - Width (In.)	10 x 6	10 x 6**	10 x 7	10 x 7
No. Used	1	1	1	1
Speeds (No.)	4	4	4	4
CFM vs. in. w.g.	See Fan Performance Table	See Fan Performance Table	See Fan Performance Table	See Fan Performance Table
Motor HP	1/5	1/3	1/3	1/3
R.P.M.	1080	1075	1075	1075
Volts / Ph / Hz	115/1/60	115/1/60	115/1/60	115/1/60
<b>COMBUSTION FAN - Type</b>	Centrifugal	Centrifugal	Centrifugal	Centrifugal
Drive - No. Speeds	Direct - 1	Direct - 1	Direct - 1	Direct - 1
Motor HP - RPM	1/50 - 3180	1/50 - 3180	1/50 - 3180	1/50 - 3180
Volts / Ph / Hz	115/1/60	115/1/60	115/1/60	115/1/60
FLA	1.09	1.09	1.09	1.09
<b>FILTER — Furnished?</b>	No	No	No	No
Type Recommended	High Velocity	High Velocity	High Velocity	High Velocity
Hi Vel. (No.-Size-Thk.)	1 - 16x25 - 1in.	1 - 16x25 - 1in.	1 - 16x25 - 1in.	1 - 17x25 - 1in.
<b>VENT — Size (in.)</b>	4 Round	4 Round	4 Round	4 Round
<b>HEAT EXCHANGER</b>				
Type -Fired	Alum. Steel	Alum. Steel	Alum. Steel	Alum. Steel
-Unfired	-	-	-	-
Gauge (Fired)	20	20	20	20
<b>ORIFICES — Main</b>				
Nat. Gas. Qty. — Drill Size	2 — 45	3 — 45	3 — 45	4 — 45
L.P. Gas Qty. — Drill Size	2 — 56	3 — 56	3 — 56	4 — 56
<b>GAS VALVE</b>	Redundant - Single Stage	Redundant - Single Stage	Redundant - Single Stage	Redundant - Single Stage
<b>PILOT SAFETY DEVICE</b>				
Type	Hot Surface Ignition	Hot Surface Ignition	Hot Surface Ignition	Hot Surface Ignition
<b>BURNERS — Type</b>	Multi-port In-shot	Multi-port In-shot	Multi-port In-shot	Multi-port In-shot
Number	2	3	3	4
<b>POWER CONN. — V / Ph / Hz ④</b>	115/1/60	115/1/60	115/1/60	115/1/60
Ampacity (In Amps)	5.4	9.0	9.0	9.0
Max. Overcurrent Protection (Amps)	15	15	15	15
<b>PIPE CONN. SIZE (IN.)</b>	1/2	1/2	1/2	1/2
<b>DIMENSIONS</b>	H x W x D	H x W x D	H x W x D	H x W x D
Crated (In.)	41-3/4 x 16-1/2 x 30-1/2	41-3/4 x 16-1/2 x 30-1/2	41-3/4 x 19-1/2 x 30-1/2	41-3/4 x 19-1/2 x 30-1/2
<b>WEIGHT</b>				
Shipping (Lbs.) / Net (Lbs.)	119 / 110	127 / 118	137 / 127	142 / 132

\*\* CUB1A060A9361A was built with a 10 X 7 blower housing, however the 10 X 7 and 10 X 6 have identical airflow in this model.

- ① Central Furnace heating designs are certified by AGA and CSA.
- ② For U.S. applications, above input ratings (BTUH) are up to 2,000 ft., derate 4% per 1,000 ft. for elevations above 2,000 ft. above sea level.  
For Canadian applications, above input ratings (BTUH) are up to 4,500 ft., derate 4% per 1,000 ft. for elevations above 4,500 ft. above sea level.
- ③ Based on U.S. government standard tests.
- ④ The above wiring specifications are in accordance with National Electrical Code; however, installations must comply with local codes.

**⚠ WARNING**

**BODILY INJURY CAN RESULT FROM HIGH VOLTAGE ELECTRICAL COMPONENTS, FAST MOVING FANS, AND COMBUSTIBLE GAS. FOR PROTECTION FROM THESE INHERENT HAZARDS DURING INSTALLATION AND SERVICING, THE ELECTRICAL SUPPLY MUST BE DISCONNECTED AND THE MAIN GAS VALVE MUST BE TURNED OFF. IF OPERATING CHECKS MUST BE PERFORMED WITH THE UNIT OPERATING, IT IS THE TECHNICIAN'S RESPONSIBILITY TO RECOGNIZE THESE HAZARDS AND PROCEED SAFELY.**

**⚠ WARNING**

**TO PREVENT AN EXPLOSION OR POSSIBLE INJURY, DEATH AND EQUIPMENT DAMAGE, DO NOT STORE COMBUSTIBLE MATERIALS, GASOLINE OR OTHER FLAMMABLE VAPORS OR LIQUIDS NEAR THE UNIT.**

# Maintenance and Service

## PRODUCT SPECIFICATIONS <sup>①</sup>

MODEL	CUB1B080A9481A	CUB1B100A9361A	CUB1C100A9481A
<b>TYPE</b>	Upflow	Upflow	Upflow
<b>RATINGS <sup>②</sup></b>			
Input BTUH <sup>③</sup>	80,000	100,000	100,000
Capacity BTUH (ICS) <sup>③</sup>	64,000	79,000	79,000
Temp. rise (Min.-Max.) °F.	30 - 60	40 - 70	35 - 65
AFUE	80.0	80.0	80.0
<b>BLOWER DRIVE</b>			
Diameter - Width (In.)	Direct 10 x 8	Direct 10 x 7	Direct 10 x 8
No. Used	1	1	1
Speeds (No.)	4	4	4
CFM vs. in. w.g.	See Fan Performance Table	See Fan Performance Table	See Fan Performance Table
Motor HP	1/3	1/3	1/2
R.P.M.	1075	1075	1075
Volts / Ph / Hz	115/1/60	115/1/60	115/1/60
<b>COMBUSTION FAN - Type</b>	Centrifugal	Centrifugal	Centrifugal
Drive - No. Speeds	Direct - 1	Direct - 1	Direct - 1
Motor HP - RPM	1/50 - 3180	1/50 - 3180	1/50 - 3180
Volts / Ph / Hz	115/1/60	115/1/60	115/1/60
FLA	1.09	1.09	1.09
<b>FILTER — Furnished?</b>	No	No	No
Type Recommended	High Velocity	High Velocity	High Velocity
Hi Vel. (No.-Size-Thk.)	1 - 17x25 - 1in.	1 - 17x25 - 1in.	1 - 20x25 - 1in.
<b>VENT — Size (in.)</b>	4 Round	4 Round	4 Round
<b>HEAT EXCHANGER</b>			
Type -Fired	Alum. Steel	Alum. Steel	Alum. Steel
-Unfired			
Gauge (Fired)	20	20	20
<b>ORIFICES — Main</b>			
Nat. Gas Qty. — Drill Size	4 — 45	5 — 45	5 — 45
L.P. Gas Qty. — Drill Size	4 — 56	5 — 56	5 — 56
<b>GAS VALVE</b>	Redundant - Single Stage	Redundant - Single Stage	Redundant - Single Stage
<b>PILOT SAFETY DEVICE</b>			
Type	Hot Surface Ignition	Hot Surface Ignition	Hot Surface Ignition
<b>BURNERS — Type</b>	Multi-port In-shot	Multi-port In-shot	Multi-port In-shot
Number	4	5	5
<b>POWER CONN. — V / Ph / Hz <sup>④</sup></b>	115/1/60	115/1/60	115/1/60
Ampacity (In Amps)	9.8	9.0	11.6
Max. Overcurrent Protection (Amps)	15	15	15
<b>PIPE CONN. SIZE (IN.)</b>	1/2	1/2	1/2
<b>DIMENSIONS</b>			
Crated (In.)	H x W x D 41-3/4 x 19-1/2 x 30-1/2	H x W x D 41-3/4 x 19-1/2 x 30-1/2	H x W x D 41-3/4 x 23 x 30-1/2
<b>WEIGHT</b>			
Shipping (Lbs.) / Net (Lbs.)	142 / 132	151 / 141	162 / 151

① Central Furnace heating designs are certified by AGA and CSA.

② For U.S. applications, above input ratings (BTUH) are up to 2,000 ft., derate 4% per 1,000 ft. for elevations above 2,000 ft. above sea level.

For Canadian applications, above input ratings (BTUH) are up to 4,500 ft., derate 4% per 1,000 ft. for elevations above 4,500 ft. above sea level.

③ Based on U.S. government standard tests.

④ The above wiring specifications are in accordance with National Electrical Code; however, installations must comply with local codes.

MODEL	CUB1C100A9601A	CUB1D120A9601A	CUB1D140A9601A
<b>TYPE</b>	Upflow	Upflow	Upflow
<b>RATINGS <sup>②</sup></b>			
Input BTUH <sup>③</sup>	100,000	120,000	140,000
Capacity BTUH (ICS) <sup>③</sup>	79,000	96,000	111,000
Temp. rise (Min.-Max.) °F.	30 - 60	30 - 60	40 - 70
AFUE	80.0	80.0	80.0
<b>BLOWER DRIVE</b>			
Diameter - Width (In.)	Direct 11 x 10	Direct 11 x 10	Direct 11 x 10
No. Used	1	1	1
Speeds (No.)	4	4	4
CFM vs. in. w.g.	See Fan Performance Table	See Fan Performance Table	See Fan Performance Table
Motor HP	3/4	3/4	3/4
R.P.M.	1075	1075	1075
Volts / Ph / Hz	115/1/60	115/1/60	115/1/60
<b>COMBUSTION FAN - Type</b>	Centrifugal	Centrifugal	Centrifugal
Drive - No. Speeds	Direct - 1	Direct - 1	Direct - 1
Motor HP - RPM	1/50 - 3180	1/50 - 3180	1/50 - 3180
Volts / Ph / Hz	115/1/60	115/1/60	115/1/60
FLA	1.09	1.09	1.09
<b>FILTER — Furnished?</b>	No	No	No
Type Recommended	High Velocity	High Velocity	High Velocity
Hi Vel. (No.-Size-Thk.)	1 - 20x25 - 1in.	1 - 24x25 - 1in.	1 - 24x25 - 1in.
<b>VENT — Size (in.)</b>	4 Round	4 Round	4 Round
<b>HEAT EXCHANGER</b>			
Type -Fired	Alum. Steel	Alum. Steel	Alum. Steel
-Unfired			
Gauge (Fired)	20	20	20
<b>ORIFICES — Main</b>			
Nat. Gas Qty. — Drill Size	5 — 45	6 — 45	7 — 45
L.P. Gas Qty. — Drill Size	5 — 56	6 — 56	7 — 56
<b>GAS VALVE</b>	Redundant - Single Stage	Redundant - Single Stage	Redundant - Single Stage
<b>PILOT SAFETY DEVICE</b>			
Type	Hot Surface Ignition	Hot Surface Ignition	Hot Surface Ignition
<b>BURNERS — Type</b>	Multi-port In-shot	Multi-port In-shot	Multi-port In-shot
Number	5	6	7
<b>POWER CONN. — V / Ph / Hz <sup>④</sup></b>	115/1/60	115/1/60	115/1/60
Ampacity (In Amps)	13.4	13.4	13.8
Max. Overcurrent Protection (Amps)	20	20	20
<b>PIPE CONN. SIZE (IN.)</b>	1/2	1/2	1/2
<b>DIMENSIONS</b>			
Crated (In.)	H x W x D 41-3/4 x 23 x 30-1/2	H x W x D 41-3/4 x 26-1/2 x 30-1/2	H x W x D 41-3/4 x 26-1/2 x 30-1/2
<b>WEIGHT</b>			
Shipping (Lbs.) / Net (Lbs.)	162 / 151	186 / 174	193 / 181

## PRODUCT SPECIFICATIONS ①

MODEL	CDB1A060A9361A	CDB1B060A9361A	CDB1B080A9451A
TYPE	Downflow / Horizontal	Downflow / Horizontal	Downflow / Horizontal
<b>RATINGS ②</b>			
Input BTUH ③	60,000	60,000	80,000
Capacity BTUH (ICS) ③	48,000	48,000	64,000
Temp. rise (Min.-Max.) °F.	30 - 60	30 - 60	35 - 65
AFUE	80.0	80.0	80.0
<b>BLOWER DRIVE</b>			
Diameter - Width (In.)	Direct 10 x 7	Direct 10 x 7	Direct 10 x 8
No. Used	1	1	1
Speeds (No.)	4	4	4
CFM vs. in. w.g.	See Fan Performance Table	See Fan Performance Table	See Fan Performance Table
Motor HP	1/3	1/2	1/3
R.P.M.	1075	1075	1075
Volts / Ph / Hz	115/1/60	115/1/60	115/1/60
<b>COMBUSTION FAN - Type</b>	Centrifugal	Centrifugal	Centrifugal
Drive - No. Speeds	Direct - 1	Direct - 1	Direct - 1
Motor HP - RPM	1/50 - 3180	1/50 - 3180	1/50 - 3180
Volts / Ph / Hz	115/1/60	115/1/60	115/1/60
FLA	1.09	1.09	1.09
<b>FILTER — Furnished?</b>	No	No	No
Type Recommended	High Velocity	High Velocity	High Velocity
Hi Vel. (No.-Size-Thk.)	2 - 14x20 - 1in.	2 - 14x20 - 1in.	2 - 14x20 - 1in.
<b>VENT — Size (in.)</b>	4 Round	4 Round	4 Round
<b>HEAT EXCHANGER</b>			
Type -Fired	Alum. Steel - Type I	Alum. Steel - Type I	Alum. Steel - Type I
-Unfired			
Gauge (Fired)	20	20	20
<b>ORIFICES — Main</b>			
Nat. Gas Qty. — Drill Size	3 — 45	3 — 45	4 — 45
L.P. Gas Qty. — Drill Size	3 — 56	3 — 56	4 — 56
<b>GAS VALVE</b>	Redundant - Single Stage	Redundant - Single Stage	Redundant - Single Stage
<b>PILOT SAFETY DEVICE</b>			
Type	Hot Surface Ignition	Hot Surface Ignition	Hot Surface Ignition
<b>BURNERS — Type</b>	Multi-port In-shot	Multi-port In-shot	Multi-port In-shot
Number	3	3	4
<b>POWER CONN. — V / Ph / Hz ④</b>	115/1/60	115/1/60	115/1/60
Ampacity (In Amps)	9.0	11.6	9.8
Max. Overcurrent Protection (Amps)	15	15	15
<b>PIPE CONN. SIZE (IN.)</b>	1/2	1/2	1/2
<b>DIMENSIONS</b>	H x W x D	H x W x D	H x W x D
Crated (In.)	41-3/4 x 19-1/2 x 30-1/2	41-3/4 x 16-1/2 x 30-1/2	41-3/4 x 19-1/2 x 30-1/2
<b>WEIGHT</b>			
Shipping (Lbs.) / Net (Lbs.)	135 / 125	129 / 119	146 / 135

① Central Furnace heating designs are certified by AGA and CSA.

② For U.S. applications, above input ratings (BTUH) are up to 2,000 ft., derate 4% per 1,000 ft. for elevations above 2,000 ft. above sea level.

For Canadian applications, above input ratings (BTUH) are up to 4,500 ft., derate 4% per 1,000 ft. for elevations above 4,500 ft. above sea level.

③ Based on U.S. government standard tests.

④ The above wiring specifications are in accordance with National Electrical Code; however, installations must comply with local codes.

MODEL	CDB1B100A9451A	CDB1C100A9601A	CDB1D120A9601A
TYPE	Downflow / Horizontal	Downflow / Horizontal	Downflow / Horizontal
<b>RATINGS ②</b>			
Input BTUH ③	100,000	100,000	120,000
Capacity BTUH (ICS) ③	80,000	81,000	96,000
Temp. rise (Min.-Max.) °F.	35 - 65	30 - 60	30 - 60
AFUE	80.0	80.0	80.0
<b>BLOWER DRIVE</b>			
Diameter - Width (In.)	Direct 10 x 8	Direct 11 x 10	Direct 11 x 10
No. Used	1	1	1
Speeds (No.)	4	4	4
CFM vs. in. w.g.	See Fan Performance Table	See Fan Performance Table	See Fan Performance Table
Motor HP	1/3	3/4	3/4
R.P.M.	1075	1075	1075
Volts / Ph / Hz	115/1/60	115/1/60	115/1/60
<b>COMBUSTION FAN - Type</b>	Centrifugal	Centrifugal	Centrifugal
Drive - No. Speeds	Direct - 1	Direct - 1	Direct - 1
Motor HP - RPM	1/50 - 3180	1/50 - 3180	1/50 - 3180
Volts / Ph / Hz	115/1/60	115/1/60	115/1/60
FLA	1.09	1.09	1.09
<b>FILTER — Furnished?</b>	No	No	No
Type Recommended	High Velocity	High Velocity	High Velocity
Hi Vel. (No.-Size-Thk.)	2 - 14x20 - 1in.	2 - 16x20 - 1in.	2 - 16x20 - 1in.
<b>VENT — Size (in.)</b>	4 Round	4 Round	4 Round
<b>HEAT EXCHANGER</b>			
Type -Fired	Alum. Steel - Type I	Alum. Steel - Type I	Alum. Steel - Type I
-Unfired			
Gauge (Fired)	20	20	20
<b>ORIFICES — Main</b>			
Nat. Gas Qty. — Drill Size	5 — 45	5 — 45	6 — 45
L.P. Gas Qty. — Drill Size	5 — 56	5 — 56	6 — 56
<b>GAS VALVE</b>	Redundant - Single Stage	Redundant - Single Stage	Redundant - Single Stage
<b>PILOT SAFETY DEVICE</b>			
Type	Hot Surface Ignition	Hot Surface Ignition	Hot Surface Ignition
<b>BURNERS — Type</b>	Multi-port In-shot	Multi-port In-shot	Multi-port In-shot
Number	5	5	6
<b>POWER CONN. — V / Ph / Hz ④</b>	115/1/60	115/1/60	115/1/60
Ampacity (In Amps)	9.8	13.4	13.4
Max. Overcurrent Protection (Amps)	15	20	20
<b>PIPE CONN. SIZE (IN.)</b>	1/2	1/2	1/2
<b>DIMENSIONS</b>	H x W x D	H x W x D	H x W x D
Crated (In.)	41-3/4 x 19-1/2 x 30-1/2	41-3/4 x 23 x 30-1/2	41-3/4 x 26-1/2 x 30-1/2
<b>WEIGHT</b>			
Shipping (Lbs.) / Net (Lbs.)	156 / 145	167 / 155	189 / 176

# Maintenance and Service

## SEQUENCE OF OPERATION

### Thermostat call for heat

R and W thermostat contacts close signaling the control module to run its self-check routine. After the control module has verified that the pressure switch contacts are open and the limit switch(es) contacts are closed, the draft blower will be energized.

As the induced draft blower comes up to speed, the pressure switch contacts will close and the ignitor warm up period will begin. The ignitor will heat for approx. 17 seconds, then the gas valve is energized to permit gas flow to the burners. The flame sensor confirms that ignition has been achieved within the 4 second ignition trial period.

After the flame sensor confirms that ignition has been achieved, the delay fan ON period (fixed at 45 seconds) begins timing. After the delay of 45 seconds, the indoor blower motor will be energized and will continue to run during the heating cycle.

When the thermostat is satisfied, R and W thermostat contacts open, the gas valve will close, the flames will extinguish, and the induced draft blower will be de-energized. The indoor blower motor will continue to run for the fan off period (fixed at 100 seconds), then will be de-energized by the control module.

### AIRFLOW ADJUSTMENT

Check inlet and outlet air temperatures to make sure they are within the ranges specified on the furnace rating nameplate. If the airflow needs to be increased or decreased, see the wiring diagram for information on changing the speed of the blower motor.

## WARNING

**Disconnect power to the unit before removing the blower door.**

This unit is equipped with a blower door switch which cuts power to the blower and gas valve causing shutdown when the door is removed. Operation with the door removed or ajar can permit the escape of dangerous fumes. All panels must be securely closed at all times for safe operation of the furnace.

## INDOOR BLOWER TIMING

[See Figure "Cooling Fan Delay" and Wiring Diagram]

**Heating:** The control module controls the indoor blower. The blower start is fixed at 45 seconds after ignition. The FAN-OFF period is fixed at 100 seconds.

**Cooling:** The fan delay off period is factory set at 0 seconds. The option for 80 second delay off is field selectable by clipping a jumper on the integrated furnace control board (See wiring diagram).

### NOTE:

**Direct drive motors have bearings which are permanently lubricated and under normal use, lubrication is not recommended.**

## ABNORMAL CONDITIONS

### 1. EXCESSIVE COMBUSTION VENT PRESSURE OR FLUE BLOCKAGE

If pressure against the induced draft blower outlet becomes excessive, the pressure switch will shut off the gas valve until acceptable combustion pressure is again available.

### 2. LOSS OF FLAME OR GAS SUPPLY FAILURE

If loss of flame occurs during a heating cycle (when flame is not present at the sensor), the control module will retry the ignition sequence up to two times after the sensor cools. If ignition is not achieved, it will lockout the furnace.

### 3. POWER FAILURE

If there is a power failure during a heating cycle, the system will restart the ignition sequence automatically when power is restored, if the thermostat still calls for heat.

### 4. INDUCED DRAFT BLOWER FAILURE

If pressure is not sensed by the pressure switch, it will not allow the gas valve to open, therefore the unit will not start. If failure occurs during a running cycle, the pressure switch will cause the gas valve to close and shut the unit down.

## INTEGRATED FURNACE CONTROL ERROR FLASH CODES

Flashing Slow ---	Normal - No call for Heat
Flashing Fast ---	Normal - Call for Heat
Continuous ON ---	Replace IFC
Continuous OFF ---	Check Power
2 Flashes ---	System Lockout (Retries or Recycles exceeded)
3 Flashes ---	Draft Pressure Error - Possible problems: a) Venting problem b) Pressure switch problem c) Inducer problem
4 Flashes ---	Open Temperature Limit Circuit
5 Flashes ---	Flame sensed when no flame should be present
6 Flashes ---	115 volt AC power reversed, poor grounding or system voltage too low
7 Flashes ---	Gas valve circuit error
8 Flashes ---	Low flame sense signal

WIRING DIAGRAM

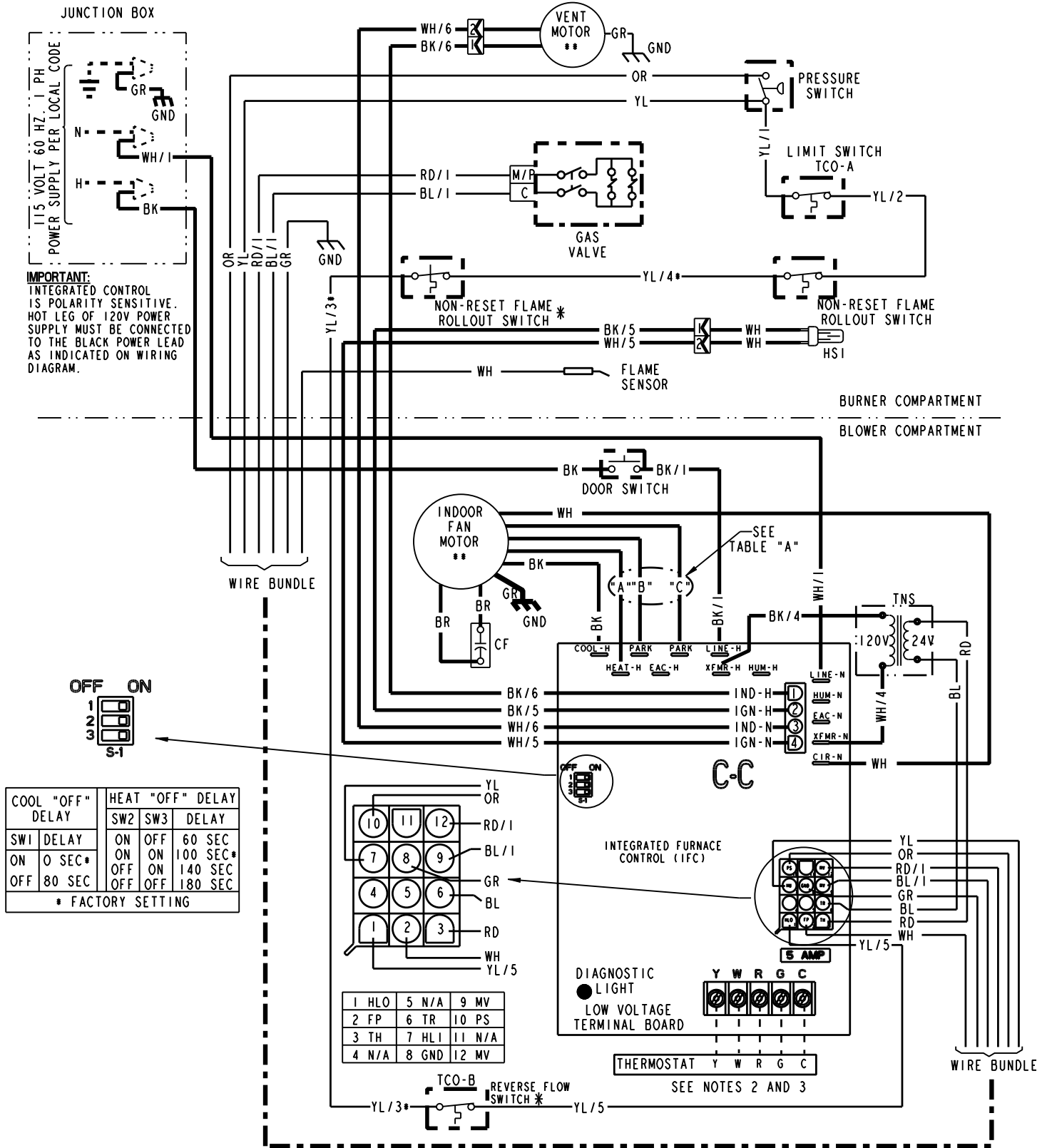

**IMPORTANT:**  
INTEGRATED CONTROL IS POLARITY SENSITIVE. HOT LEG OF 120V POWER SUPPLY MUST BE CONNECTED TO THE BLACK POWER LEAD AS INDICATED ON WIRING DIAGRAM.

COOL "OFF" DELAY		HEAT "OFF" DELAY		
SW1	DELAY	SW2	SW3	DELAY
ON	0 SEC*	ON	ON	60 SEC
OFF	80 SEC	OFF	ON	100 SEC*
		OFF	OFF	140 SEC
		OFF	OFF	180 SEC

\* FACTORY SETTING

1	HLO	5	N/A	9	MV
2	FP	6	TR	10	PS
3	TH	7	HLI	11	N/A
4	N/A	8	GND	12	MV

\* COMPONENTS FOR AUE1 MODELS ONLY

SCHEMATIC DIAGRAM

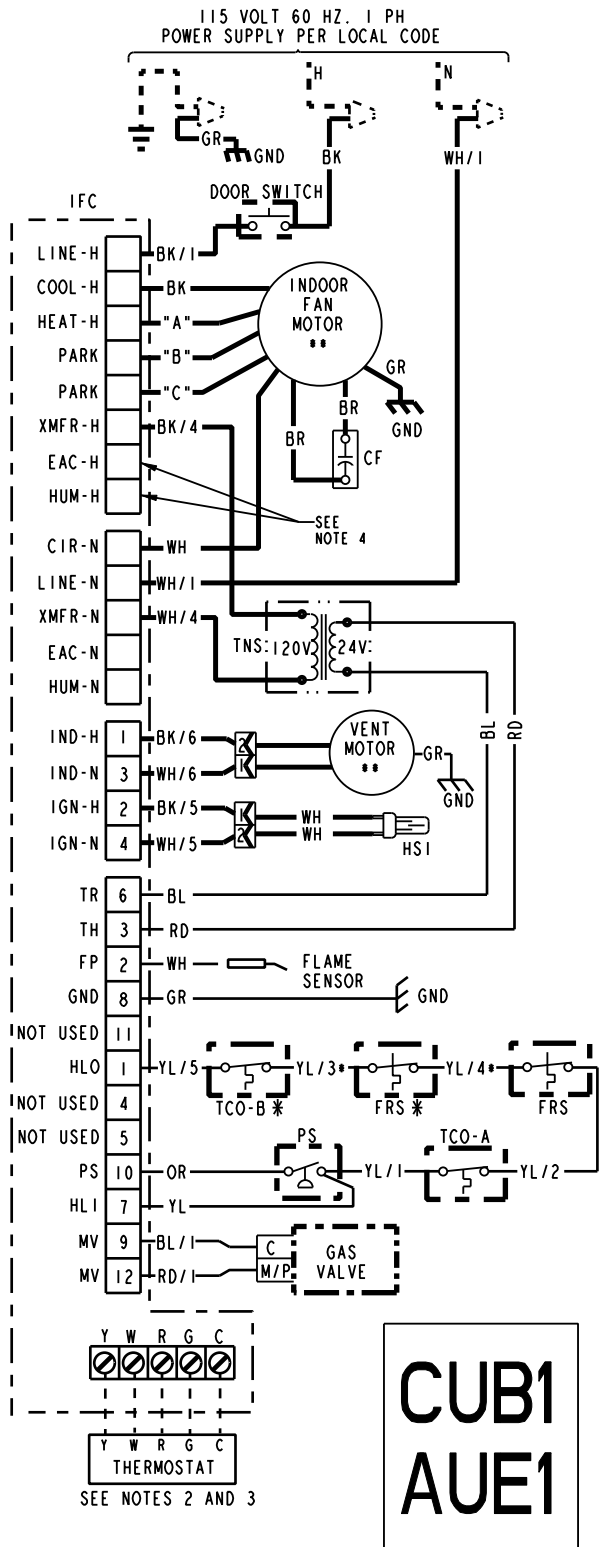

**TABLE "A"**  
SPEED TAPS FOR I. D. FAN MOTOR

MODEL	HEAT "A"	PARK "B"	PARK "C"
CUB1A040A9241A* AUE1A040A9241A*	YL	RD	BL
CUB1A060A9241A* AUE1A060A9241A*	BL	RD	YL
CUB1A060A9361A* AUE1A060A9361A*	YL	RD	BL
CUB1B060A9361A* AUE1B060A9361A*	RD	BL	YL
CUB1B080A9361A* AUE1B080A9361A*	BL	RD	YL
CUB1B080A9481A* AUE1B080A9481A*	BL	RD	YL
CUB1B100A9361A* AUE1B100A9361A*	BL	RD	YL
CUB1C100A9481A* AUE1C100A9481A*	BL	RD	YL
CUB1C100A9601A* AUE1C100A9601A*	YL	RD	BL
CUB1D120A9601A* AUE1D120A9601A*	BL	RD	YL
CUB1D140A9601A* AUE1D140A9601A*	BL	RD	YL

\* MAY BE A THROUGH Z  
RD=LOW YL=MED. LOW BL=MED. HIGH BK=HIGH

**WARNING**  
HAZARDOUS VOLTAGE:  
DISCONNECT ALL ELECTRICAL POWER INCLUDING REMOTE DISCONNECTS BEFORE SERVICING.  
FAILURE TO DISCONNECT POWER BEFORE SERVICING CAN CAUSE SEVERE PERSONAL INJURY OR DEATH.

**CAUTION**  
USE COPPER CONDUCTORS ONLY!  
UNIT TERMINALS ARE NOT DESIGNED TO ACCEPT OTHER TYPES OF CONDUCTORS.  
FAILURE TO DO SO MAY CAUSE DAMAGE TO THE EQUIPMENT.

**INTEGRATED FURNACE CONTROL**  
REPLACE WITH PART CNT02891 OR CNT 02183 OR EQUIVALENT  
INPUT: 25 VAC, 60 HZ.  
XFMR SEC. CURRENT: 450 MA.  
MV OUTPUT: 1.5 A @ 24 VAC  
IND OUTPUT: 2.2 FLA, 3.5 LRA @ 120 VAC  
CIRC. BLOWER OUTPUT: 14.5 FLA, 26 LRA @ 120 VAC  
HUMIDIFIER & AIR CLEANER  
MAX. LOAD: 1.0 A @ 120 VAC  
IGNITER OUTPUT: 6.0 A @ 120 VAC

**DIAGNOSTIC CODES**

FLASHING SLOW: NORMAL - NO CALL FOR HEAT  
FLASHING FAST: NORMAL - CALL FOR HEAT  
CONTINUOUS ON: REPLACE IFC  
CONTINUOUS OFF: CHECK POWER  
2 FLASHES: EXTERNAL LOCKOUT (RETRIES OR RECYCLES EXCEEDED)  
3 FLASHES: PRESSURE SWITCH ERROR  
4 FLASHES: OPEN LIMIT DEVICE  
5 FLASHES: FLAME SENSED WHEN NO FLAME SHOULD BE PRESENT  
6 FLASHES: 115 VAC POWER REVERSED POLARITY OR POOR GROUNDING  
7 FLASHES: GAS VALVE CIRCUIT ERROR  
8 FLASHES: LOW FLAME SENSE SIGNAL

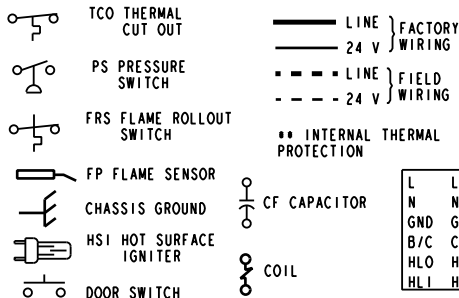

BK	BLACK	GR	GREEN
WH	WHITE	BR	BROWN
YL	YELLOW	RD	RED
OR	ORANGE	BL	BLUE

WIRE COLOR  
BK/1 NUMBER ID (IF ANY)

L	LINE	TH	24 VAC (HOT)
N	NEUTRAL	TR	24 VAC (COMMON)
GND	GROUND	MV	MAIN GAS VALVE
B/C	COMMON	TNS	TRANSFORMER
HLO	HIGH LIMIT OUTPUT		
HLI	HIGH LIMIT INPUT		

**NOTES:**

- IF ANY OF THE ORIGINAL WIRING AS SUPPLIED WITH THIS FURNACE MUST BE REPLACED, IT MUST BE WITH WIRE HAVING A TEMPERATURE RATING OF AT LEAST 105 C.
- THERMOSTAT HEAT ANTICIPATOR SETTING: .38 AMPS
- FOR PROPER OPERATION OF COOLING SPEED, "Y" TERMINAL MUST BE CONNECTED TO THE ROOM THERMOSTAT.
- THESE TERMINALS PROVIDE 120V POWER CONNECTIONS FOR ELECTRONIC AIR CLEANER (EAC) AND HUMIDIFIER (HUM). MAX. LOAD: 1.0 AMPS EACH.

**CUB1**  
**AUE1**

D342779P01 REV03

From Dwg. D342779P01 Rev. 05

WIRING DIAGRAM

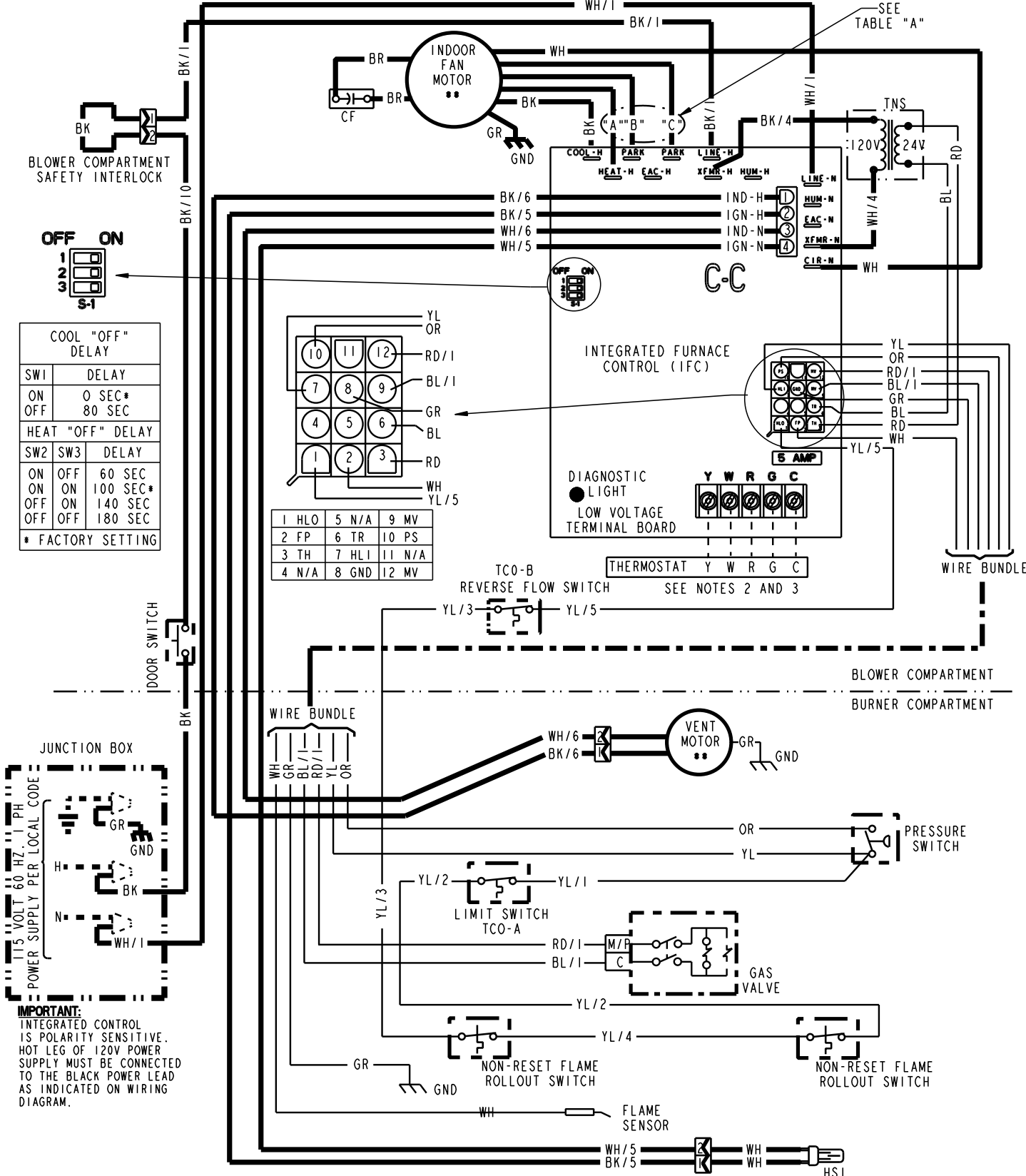

BLOWER COMPARTMENT SAFETY INTERLOCK

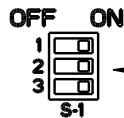

COOL "OFF" DELAY		
SW1	DELAY	
ON	0 SEC*	
OFF	80 SEC	
HEAT "OFF" DELAY		
SW2	SW3	DELAY
ON	OFF	60 SEC
ON	ON	100 SEC*
OFF	ON	140 SEC
OFF	OFF	180 SEC

\* FACTORY SETTING

1 HLO	5 N/A	9 MV
2 FP	6 TR	10 PS
3 TH	7 HLI	11 N/A
4 N/A	8 GND	12 MV

THERMOSTAT Y W R G C  
SEE NOTES 2 AND 3

BLOWER COMPARTMENT  
BURNER COMPARTMENT

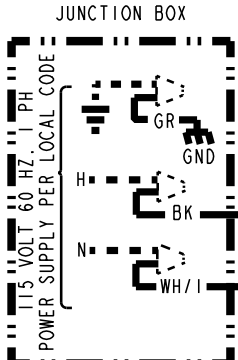

**IMPORTANT:**  
INTEGRATED CONTROL IS POLARITY SENSITIVE. HOT LEG OF 120V POWER SUPPLY MUST BE CONNECTED TO THE BLACK POWER LEAD AS INDICATED ON WIRING DIAGRAM.

From Dwg. D342780P01 Rev. 01

(continued on next page)

## SCHEMATIC DIAGRAM

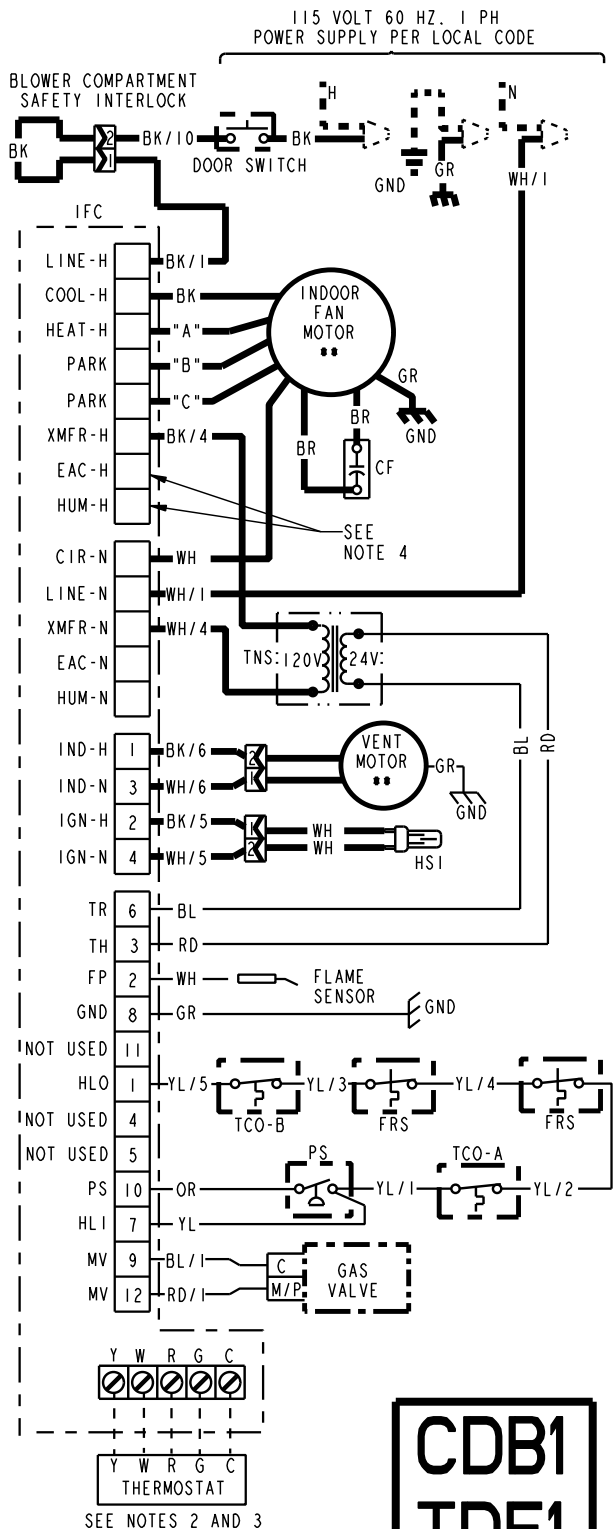

**CDB1  
TDE1  
ADE1**

D342780P01 REV01

TABLE "A"			
SPEED TAPS FOR I. D. FAN MOTOR			
MODEL	HEAT "A"	PARK "B"	PARK "C"
CDB1A060A9361A*	YL	RD	BL
TDE1A060A9361A*			
ADE1A060A9361A*			
CDB1B060A9361A*	RD	BL	YL
TDE1B060A9361A*			
ADE1B060A9361A*			
CDB1B080A9451A*	BL	RD	YL
TDE1B080A9451A*			
ADE1B080A9451A*			
CDB1B100A9451A*	BL	RD	YL
TDE1B100A9451A*			
ADE1B100A9451A*			
CDB1C100A9601A*	YL	RD	BL
TDE1C100A9601A*			
ADE1C100A9601A*			
CDB1D120A9601A*	BL	RD	YL
TDE1D120A9601A*			
ADE1D120A9601A*			

RD = LOW  
YL = MED. LOW  
BL = MED. HIGH  
BK = HIGH

\* - MAY BE A THROUGH Z

**WARNING**

HAZARDOUS VOLTAGE:  
DISCONNECT ALL ELECTRICAL POWER INCLUDING REMOTE DISCONNECTS BEFORE SERVICING.  
FAILURE TO DISCONNECT POWER BEFORE SERVICING CAN CAUSE SEVERE PERSONAL INJURY OR DEATH.

**CAUTION**

USE COPPER CONDUCTORS ONLY!  
UNIT TERMINALS ARE NOT DESIGNED TO ACCEPT OTHER TYPES OF CONDUCTORS.  
FAILURE TO DO SO MAY CAUSE DAMAGE TO THE EQUIPMENT.

**INTEGRATED FURNACE CONTROL**  
REPLACE WITH PART CNT02891 OR CNT 02183 OR EQUIVALENT  
INPUT: 25 VAC, 60 HZ.  
XFMR SEC. CURRENT: 450 MA.  
MV OUTPUT: 1.5 A @ 24 VAC  
IND OUTPUT: 2.2 FLA, 3.5 LRA @ 120 VAC  
CIRC. BLOWER OUTPUT: 14.5 FLA, 26 LRA @ 120 VAC  
HUMIDIFIER & AIR CLEANER  
MAX. LOAD: 1.0 A @ 120 VAC  
IGNITER OUTPUT: 6.0 A @ 120 VAC

### DIAGNOSTIC CODES

FLASHING SLOW: NORMAL - NO CALL FOR HEAT  
FLASHING FAST: NORMAL - CALL FOR HEAT  
CONTINUOUS ON: REPLACE IFC  
CONTINUOUS OFF: CHECK POWER  
2 FLASHES: EXTERNAL LOCKOUT (RETRIES OR RECYCLES EXCEEDED)  
3 FLASHES: PRESSURE SWITCH ERROR  
4 FLASHES: OPEN LIMIT DEVICE  
5 FLASHES: FLAME SENSED WHEN NO FLAME SHOULD BE PRESENT  
6 FLASHES: 115 VAC POWER REVERSED POLARITY OR POOR GROUNDING  
7 FLASHES: GAS VALVE CIRCUIT ERROR  
8 FLASHES: LOW FLAME SENSE SIGNAL

TCO THERMAL CUT OUT	LINE } FACTORY 24 V WIRING	BK BLACK GR GREEN WH WHITE BR BROWN YL YELLOW RD RED OR ORANGE BL BLUE
PS PRESSURE SWITCH	LINE } FIELD 24 V WIRING	BK/1 WIRE COLOR NUMBER ID (IF ANY)
FRS FLAME ROLLOUT SWITCH	** INTERNAL THERMAL PROTECTION	
FP FLAME SENSOR	CF CAPACITOR	L LINE TH 24 VAC (HOT) N NEUTRAL TR 24 VAC (COMMON) GND GROUND MV MAIN GAS VALVE B/C COMMON TNS TRANSFORMER HLO HIGH LIMIT OUTPUT HLI HIGH LIMIT INPUT
CHASSIS GROUND	COIL	
HSI HOT SURFACE IGNITER		
DOOR SWITCH		

### NOTES:

- IF ANY OF THE ORIGINAL WIRING AS SUPPLIED WITH THIS FURNACE MUST BE REPLACED, IT MUST BE WITH WIRE HAVING A TEMPERATURE RATING OF AT LEAST 105 C.
- THERMOSTAT HEAT ANTICIPATOR SETTING: .38 AMPS
- FOR PROPER OPERATION OF COOLING SPEED, "Y" TERMINAL MUST BE CONNECTED TO THE ROOM THERMOSTAT.
- THESE TERMINALS PROVIDE 120V POWER CONNECTIONS FOR ELECTRONIC AIR CLEANER (EAC) AND HUMIDIFIER (HUM). MAX. LOAD: 1.0 AMPS EACH.



<b>FURNACE AIRFLOW (CFM) VS. EXTERNAL STATIC PRESSURE (IN. W.C.)</b>										
<b>MODEL</b>	<b>SPEED TAP</b>	<b>0.10</b>	<b>0.20</b>	<b>0.30</b>	<b>0.40</b>	<b>0.50</b>	<b>0.60</b>	<b>0.70</b>	<b>0.80</b>	<b>0.90</b>
CUB1A040A9241A	4 - HIGH - Black	1018	1004	982	950	910	860	802	763	660
	3 - MED.-HIGH - Blue	847	832	809	779	742	697	644	585	517
	2 - MED.-LOW - Yellow	716	701	678	648	610	585	512	452	384
	1 - LOW - Red	617	599	575	544	507	463	413	357	294
CUB1A060A9241A	4 - HIGH - Black	1013	997	973	941	901	852	796	731	659
	3 - MED.-HIGH - Blue	835	821	800	771	734	689	636	575	506
	2 - MED.-LOW - Yellow	712	702	683	655	617	571	516	452	379
	1 - LOW - Red	611	596	573	543	505	459	406	345	277
CUB1A060A9361A	4 - HIGH - Black	1426	1389	1345	1298	1236	1171	1099	1020	934
	3 - MED.-HIGH - Blue	1243	1225	1197	1160	1113	1057	991	916	831
	2 - MED.-LOW - Yellow	1042	1039	1027	1005	973	931	879	817	745
	1 - LOW - Red	900	903	895	877	848	809	760	700	629
CUB1B060A9361A	4 - HIGH - Black	1426	1389	1345	1298	1236	1171	1099	1020	934
	3 - MED.-HIGH - Blue	1243	1225	1197	1160	1113	1057	991	916	831
	2 - MED.-LOW - Yellow	1042	1039	1027	1005	973	931	879	817	745
	1 - LOW - Red	900	903	895	877	848	809	760	700	629
CUB1B080A9361A	4 - HIGH - Black	1393	1384	1364	1335	1296	1247	1189	1120	1042
	3 - MED.-HIGH - Blue	1210	1209	1198	1177	1147	1107	1058	999	930
	2 - MED.-LOW - Yellow	1046	1052	1047	1033	1008	973	928	873	808
	1 - LOW - Red	900	903	895	888	869	842	808	766	717
CUB1B080A9481A	4 - HIGH - Black	1839	1821	1796	1756	1710	1641	1573	1480	1392
	3 - MED.-HIGH - Blue	1323	1325	1329	1319	1308	1275	1246	1201	1165
	2 - MED.-LOW - Yellow	1092	1090	1091	1083	1076	1059	1040	1005	970
	1 - LOW - Red	788	783	780	768	758	737	719	674	630
CUB1B100A9361A	4 - HIGH - Black	1476	1464	1441	1408	1363	1307	1241	1163	1074
	3 - MED.-HIGH - Blue	1249	1257	1252	1234	1203	1158	1101	1030	946
	2 - MED.-LOW - Yellow	1020	1046	1058	1050	1028	990	936	866	780
	1 - LOW - Red	873	887	890	883	864	834	794	742	680
CUB1C100A9481A	4 - HIGH - Black	1880	1846	1799	1740	1669	1595	1489	1381	1260
	3 - MED.-HIGH - Blue	1662	1635	1598	1551	1493	1424	1345	1256	1157
	2 - MED.-LOW - Yellow	1428	1421	1402	1370	1326	1269	1199	1117	1022
	1 - LOW - Red	1208	1215	1210	1193	1164	1124	1073	1009	935
CUB1C100A9601A	4 - HIGH - Black	2181	2143	2104	2053	2001	1929	1856	1766	1676
	3 - MED.-HIGH - Blue	1908	1888	1868	1834	1800	1745	1690	1631	1572
	2 - MED.-LOW - Yellow	1621	1609	1597	1582	1567	1533	1498	1438	1377
	1 - LOW - Red	1443	1419	1395	1381	1367	1335	1302	1256	1209
CUB1D120A9601A	4 - HIGH - Black	2135	2101	2066	2036	2005	1923	1840	1750	1659
	3 - MED.-HIGH - Blue	1906	1881	1856	1817	1777	1724	1671	1602	1533
	2 - MED.-LOW - Yellow	1646	1632	1617	1596	1575	1535	1494	1427	1360
	1 - LOW - Red	1423	1415	1407	1391	1375	1338	1300	1246	1192
CUB1D140A9601A	4 - HIGH - Black	2462	2407	2351	2284	2216	2143	2069	1989	1908
	3 - MED.-HIGH - Blue	2128	2112	2096	2054	2011	1949	1887	1797	1706
	2 - MED.-LOW - Yellow	1755	1746	1736	1719	1702	1656	1609	1564	1518
	1 - LOW - Red	1450	1446	1442	1427	1411	1383	1354	1298	1241

<b>MODEL</b>	<b>CFM VS. TEMPERATURE RISE</b>																			
	<b>CFM (CUBIC FEET PER MINUTE)</b>																			
	<b>500</b>	<b>600</b>	<b>700</b>	<b>800</b>	<b>900</b>	<b>1000</b>	<b>1100</b>	<b>1200</b>	<b>1300</b>	<b>1400</b>	<b>1500</b>	<b>1600</b>	<b>1700</b>	<b>1800</b>	<b>1900</b>	<b>2000</b>	<b>2100</b>	<b>2200</b>	<b>2300</b>	<b>2400</b>
CUB1A040A9241A	54	49	42	37	33	30														
CUB1A060A9241A			63	56	49	44														
CUB1A060A9361A				56	49	44	40	37	34	32										
CUB1B060A9361A				56	49	44	40	37	34	32										
CUB1B080A9361A						59	54	49	46	42										
CUB1B080A9481A						58	52	49	46	42	40	37	35	33						
CUB1B100A9361A							67	62	57	53	49									
CUB1C100A9481A							67	62	57	53	49	46	44	41	39	37				
CUB1C100A9601A								62	57	53	49	46	44	41	39	37	35	34	32	31
CUB1D120A9601A											59	56	52	49	47	44	42	40		
CUB1D140A9601A											69	65	61	58	55	52	49	47	45	

From C340782 Sh. 1 Rev. 8

# Maintenance and Service

FURNACE AIRFLOW (CFM) VS. STATIC PRESSURE (in. w.c.)										
MODEL	SPEED TAP	0.10	0.20	0.30	0.40	0.50	0.60	0.70	0.80	0.90
CDB1A060A9361A	4 - HIGH - Black	1480	1429	1375	1318	1282	1100	1112	1029	959
	3 - MED.-HIGH - Blue	1302	1276	1229	1188	1141	1088	1024	953	882
	2 - MED.-LOW - Yellow	1115	1100	1070	1035	1000	965	918	859	790
	1 - LOW - Red	956	947	918	888	859	824	788	741	682
CDB1B060A9361A	4 - HIGH - Black	1480	1429	1375	1318	1282	1100	1112	1029	959
	3 - MED.-HIGH - Blue	1302	1276	1229	1188	1141	1088	1024	953	882
	2 - MED.-LOW - Yellow	1115	1100	1070	1035	1000	965	918	859	790
	1 - LOW - Red	956	947	918	888	859	824	788	741	682
CDB1B080A9451A	4 - HIGH - Black	1798	1750	1692	1642	1575	1500	1425	1325	1225
	3 - MED.-HIGH - Blue	1384	1367	1333	1300	1275	1233	1192	1142	1083
	2 - MED.-LOW - Yellow	1210	1150	1108	1075	1042	1008	967	925	867
	1 - LOW - Red	1005	970	808	775	767	733	700	675	617
CDB1B100A9451A	4 - HIGH - Black	1767	1731	1669	1615	1546	1469	1392	1300	1146
	3 - MED.-HIGH - Blue	1382	1354	1323	1292	1254	1207	1177	1108	1038
	2 - MED.-LOW - Yellow	1130	1138	1115	1085	1054	1015	977	938	877
	1 - LOW - Red	840	831	815	792	762	731	700	654	625
CDB1C100A9601A	4 - HIGH - Black	2165	2113	2060	1995	1929	1842	1755	1674	1593
	3 - MED.-HIGH - Blue	1962	1927	1891	1839	1786	1724	1662	1581	1500
	2 - MED.-LOW - Yellow	1705	1688	1671	1671	1600	1547	1492	1435	1377
	1 - LOW - Red	1492	1467	1442	1442	1385	1346	1307	1243	1179
CDB1D120A9601A	4 - HIGH - Black	2241	2202	2163	2106	2049	1979	1908	1804	1700
	3 - MED.-HIGH - Blue	1981	1962	1942	1904	1866	1805	1743	1680	1617
	2 - MED.-LOW - Yellow	1721	1705	1688	1671	1653	1611	1569	1515	1461
	1 - LOW - Red	1476	1466	1456	1440	1423	1392	1361	1302	1243

CFM VS. TEMPERATURE RISE																				
MODEL	CFM (CUBIC FEET PER MINUTE)																			
	500	600	700	800	900	1000	1100	1200	1300	1400	1500	1600	1700	1800	1900	2000	2100	2200	2300	2400
CDB1A060A9361A				56	49	44	40	37	34	32										
CDB1B060A9361A				56	49	44	40	37	34	32										
CDB1B080A9451A					64	57	52	48	44	41										
CDB1B100A9451A								62	57	53	49	46	44	41						
CDB1C100A9601A								62	57	53	49	46	44	41	39	37	35	34	32	31
CDB1D120A9601A											59	56	52	49	47	44	42	40		

From C330671 Sh. 3 Rev. 10

## PERIODIC SERVICING REQUIREMENTS

### WARNING

Disconnect power to the unit before removing the blower door. Failure to follow this warning could result in personal injury from moving parts.

### WARNING

#### CARBON MONOXIDE POISONING HAZARD

Failure to follow the service and/or periodic maintenance instructions for the furnace and venting system, could result in carbon monoxide poisoning or death.

1. GENERAL INSPECTION — Examine the furnace installation annually for the following items:

- All flue product carrying areas external to the furnace (i.e. chimney, vent connector) are clear and free of obstruction. A vent screen in the end of the vent (flue) pipe must be inspected for blockage annually.
- The vent connector is in place, slopes upward and is physically sound without holes or excessive corrosion.
- The return air duct connection(s) is physically sound, is sealed to the furnace and terminates outside the space containing the furnace.
- The physical support of the furnace should be sound without sagging, cracks, gaps, etc., around the base so as to provide a seal between the support and the base.
- There are no obvious signs of deterioration of the furnace.

2. FILTERS — Filters should be cleaned or replaced (with high velocity filters only), monthly and more frequently during high use times of the year such as midsummer or midwinter.

3. BLOWERS — The blower size and speed determine the air volume delivered by the furnace. The blower motor bearings are factory lubricated and under normal operating conditions do not require servicing. If motor lubrication is required it should only be done by a qualified servicer. Annual cleaning of the blower wheel and housing is recommended for maximum air output, and this must be performed only by a qualified servicer or service agency.

4. IGNITER — This unit has a hot surface direct ignition device that automatically lights the burners. Please note that it is very fragile and should be handled with care.

### WARNING

Do not touch igniter. It is extremely hot. Failure to follow this warning could result in severe burns.

5. BURNER — Gas burners do not normally require scheduled servicing, however, accumulation of foreign material may cause a yellowing flame or delayed ignition. Either condition indicates that a service call is required. For best operation, burners must be cleaned annually using brushes and vacuum cleaner.

Turn off gas and electric power supply. To clean burners, remove burner box cover (6 to 8 screws) and top burner bracket. Lift burners from orifices.

#### NOTE:

*Be careful not to break igniter when removing burners.*

Clean burners with brush and/or vacuum cleaner. Reassemble parts by reversal of the above procedure. The burner box must be resealed when replacing box cover.

#### NOTE:

*On LP (propane) units, some light yellow tipping of the outer mantle is normal. Inner mantle should be bright blue.*

Natural gas units should not have any yellow tipped flames. This condition indicates that a service call is required. For best operation, burners must be cleaned annually using brushes and vacuum cleaner.

#### NOTE:

*On LP (propane) units, due to variations in BTU content and altitude, servicing may be required at shorter intervals.*

6. HEAT EXCHANGER/FLUE PIPE — These items must be inspected for signs of corrosion, and/or deterioration at the beginning of each heating season by a qualified service technician and cleaned annually for best operation. To clean flue gas passages, follow recommendations below:

- Turn off gas and electric power supply.
- Inspect flue pipe exterior for cracks, leaks, holes or leaky joints.
- Remove burner compartment door from furnace.
- Inspect flue collector box. Inspect induced draft blower flue pipe connection.
- Remove burners. (See 4.)
- Use a mirror and flashlight to inspect interior of heat exchanger, be careful not to damage the igniter, flame sensor or other components.
- If any corrosion is present, contact a service agency. Heat exchanger should be cleaned by a qualified service technician.
- After inspection is complete replace furnace door.
- Restore gas supply. Check for leaks using a soap solution. Restore electrical supply. Check unit for normal operation.

7. COOLING COIL CONDENSATE DRAIN — If a cooling coil is installed with the furnace, condensate drains should be checked and cleaned periodically to assure that condensate can drain freely from coil to drain. If condensate cannot drain freely water damage could occur. (See Condensate Drain in Installation Section).

### CAUTION

Label all wires prior to disconnection when servicing controls. Wiring errors can cause improper and dangerous operation.

Verify proper operation after servicing.

## **Base Limited Warranty Gas Furnace**

**\*UE1, \*DE1, \*UD1, \*DD1, \*UD1-H, \*DD1-H, \*UD2, \*DD2, CUB1, CDB1, CUX1, and  
CDX1**

\* First letter may be preceded by an "A" or "T" (Parts Only)

### **Models Less Than 20 Tons for Residential Use\***

This limited warranty is provided by the manufacturer to the original purchaser and to any succeeding owner of the real property to which the gas furnace is originally affixed, and applies to products purchased and retained for use within the U.S.A. and Canada.

Beginning on January 1, 2010, R-22 refrigerant will no longer be used as a manufacturer-installed refrigerant as required by federal regulation. Following this date, depending on the availability of any remaining R-22 equipment, indoor model replacements may require that the entire system be R-410A compatible. Outdoor system components and possibly connecting line sets would need to be replaced in order to be compatible with indoor units containing R-410A refrigerant. Expenses associated with replacing system components that are not R-410A compatible will not be covered by the terms and conditions of the limited warranty.

The limited warranty period begins when installation is complete and the gas furnace start-up procedure has been properly completed, verified by installer's invoice or similar document. If installation completion and start-up date cannot be verified by installer's invoice or similar document, this limited warranty coverage begins six (6) months after the date of manufacture based on the gas furnace serial number.

If any functional part of your gas furnace fails because of a manufacturing defect within five (5) years from the date the limited warranty period begins, Warrantor will furnish without charge the required replacement part. Any other costs, such as local transportation, related service labor, diagnosis calls, refrigerant and related items are not included.

In addition, if the heat exchanger fails because of a manufacturing defect within the sixth through twentieth year from the date the limited warranty period begins, Warrantor WILL AT ITS OPTION provide either a heat exchanger without charge, or allow a credit in the amount of the then current wholesale price of an equivalent heat exchanger toward the purchase price of a comparable heating unit. Any other costs, such as local transportation, related service labor, diagnosis calls, refrigerant and related items are not included.

This limited warranty does not apply if the gas furnace was purchased direct (i.e. from internet websites or auctions) on an uninstalled basis. Additionally, this limited warranty will not apply unless the gas furnace is: (1) installed by a licensed or qualified HVAC technician, (2) applied and installed in accordance with the manufacturer's recommendations in its Installer's Guide, and (3) in compliance with all industry standards, national, state, and local codes.

This limited warranty does not cover failure of your furnace if it is damaged while in your possession; including, but not limited to (1) damage caused by unreasonable use, (2) damage from failure to properly maintain as set forth in the Use and Care manual, (3) damage that is not considered a manufacturing defect, such as acts of God, malfunctions or failures resulting from fire, water, storms, lightning, earthquake, theft, riot, misuse, abuse, increased utility usage costs, or (4) performance problems due to improper selection/equipment match, installation or application.

This limited warranty applies to product installed on or after 5/1/2009.

**THE LIMITED WARRANTY AND LIABILITY SET FORTH HEREIN ARE IN LIEU OF ALL OTHER WARRANTIES AND LIABILITIES, WHETHER IN CONTRACT OR IN NEGLIGENCE, EXPRESS OR IMPLIED, IN LAW OR IN FACT, INCLUDING BUT NOT SPECIFICALLY LIMITED TO IMPLIED WARRANTIES OF MERCHANTABILITY AND FITNESS FOR PARTICULAR USE, AND IN NO EVENT SHALL WARRANTOR BE LIABLE FOR ANY INCIDENTAL OR CONSEQUENTIAL DAMAGES.**

Some states and provinces do not allow limitations on how long an implied limited warranty lasts or do not allow the exclusion or limitation of incidental or conse-quential damages, so the above limitation or exclusion may not apply to you. This limited warranty gives you specific legal rights, and you may also have other rights which vary by jurisdiction.

Parts will be provided by our factory organization through an authorized service organization in your area listed in the yellow pages.

If you wish further help or information concerning this limited warranty, contact:

Residential Systems  
6200 Troup Highway, Tyler, TX 75707  
Attention: Customer Relations

TW-1043-1409

\* This limited warranty is for residential usage of this equipment and not applicable when this equipment is used for a commercial application.

A commercial use is any application where the end purchaser uses the product for other than personal, family or household purposes.

# **Limited Warranty**

## **Induced Draft Gas Furnace**

### **UC1, DC1, UX1, DX1, UX1-H, DX1-H, UX, DX, UY, DY, UD-R, DD-R, UD-RV, DD-RV, UD1-H, DH1, DD1-H, UD1, DD1, UE1, DE1, UH3, DH3, UX2, DX2, UH2, DH2, UD2, DD2, UHM, DHM and UH1**

#### **Models Less Than 20 Tons for Commercial Use\***

(First letter may be preceded by an "A" or "T") (Parts Only)

This limited warranty is extended by the manufacturer to the original purchaser and to any succeeding owner of the real property to which the gas furnace is originally affixed and applies to products purchased and retained for use within the U.S.A. and Canada. There is no warranty against corrosion, erosion or deterioration.

Beginning on January 1, 2010, R-22 refrigerant will no longer be used as a manufacturer-installed refrigerant as required by federal regulation. Following this date, depending on the availability of any remaining R-22 equipment, indoor model replacements may require that the entire system be R-410A compatible. Outdoor system components and possibly connecting line sets would need to be replaced in order to be compatible with indoor units containing R-410A refrigerant. Expenses associated with replacing system components that are not R-410A compatible will not be covered by the terms and conditions of the limited warranty.

The limited warranty period begins when installation is complete and the gas furnace start-up procedure has been properly completed, verified by installer's invoice or similar document. If installation completion and start-up date cannot be verified by installer's invoice or similar document, limited warranty coverage begins six (6) months after the date of manufacture based on the gas furnace serial number.

If any part of your gas furnace fails because of a manufacturing defect within one (1) year from the date the limited warranty period begins, Warrantor will furnish without charge the required replacement part. All local transportation, related service labor, and diagnostic calls, are not included.

In addition, if the steel heat exchanger fails because of a manufacturing defect within the second through twentieth year from the date the limited warranty period begins for the gas furnace, subject to proof of original purchase, Warrantor shall furnish without charge a replacement heat exchanger. Warrantor's obligations and liabilities under this warranty are limited to furnishing F.O.B. Warrantor factory or warehouse replacement parts for Warrantor's products covered under this warranty. No liability shall attach to Warrantor until products have been paid for and then liability shall be limited solely to the purchase price of the equipment under warranty shown to be defective.

This limited warranty does not apply if the gas furnace was purchased direct (i.e. from internet websites or auctions) on an uninstalled basis. Additionally, this limited warranty will not apply unless the gas furnace is: (1) installed by a licensed or qualified HVAC technician, (2) applied and installed in accordance with the manufacturer's recommendations in its Installer's Guide, and (3) in compliance with all industry standards, national, state, and local codes.

This limited warranty does not cover your gas furnace if it is damaged while in your possession; including, but not limited to (1) damage caused by unreasonable use of the gas furnace, (2) damage from failure to properly maintain the gas furnace as set forth in the Use and Care manual (refer to "Proper Maintenance" section), (3) damage that is not considered a manufacturing defect, such as acts of God, malfunctions or failures resulting from fire, water, storms, lightning, earthquake, theft, riot, misuse, abuse, increased utility usage costs, or (4) performance problems due to improper selection / equipment match-up, installation, or application.

**THE LIMITED WARRANTY AND LIABILITY SET FORTH HEREIN ARE IN LIEU OF ALL OTHER WARRANTIES AND LIABILITIES, WHETHER IN CONTRACT OR IN NEGLIGENCE, EXPRESSED OR IMPLIED, IN LAW OF IN FACT, INCLUDING IMPLIED WARRANTIES OF MERCHANTABILITY AND FITNESS FOR PARTICULAR USE, AND IN NO EVENT SHALL WARRANTOR BE LIABLE FOR ANY INCIDENTAL OR CONSEQUENTIAL DAMAGES.**

Some states do not allow limitations on how long an implied limited warranty lasts or do not allow the exclusion or limitation of incidental or consequential damages, so the above limitation or exclusion may not apply to you. This limited warranty gives you specific legal rights, and you may also have other rights which vary from state to state.

Parts will be provided by our factory organization through an authorized service organization in your area listed in the yellow pages. If you wish further help or information concerning this limited warranty, contact:

Residential Systems  
6200 Troup Highway, Tyler, TX 75707  
Attention: Consumer Relations

Or visit our website: [www.trane.com/residential](http://www.trane.com/residential)

TW-1012-2609

\* This warranty is for commercial usage of said equipment and not applicable when the equipment is used for a residential application. Commercial use is any application where the end purchaser uses the product for other than personal, family or household purposes.

# Important Product Information

Registering your products helps provide you with one of the strongest manufacturer limited warranties available. To register, go to the manufacturer's website or contact your dealer. You will need the serial number, model number, and installation date for each product being registered. Your dealer may have included these on your invoice or can provide a list for you to use. Please take a few moments to record the following information to ensure your product registration process is quick and easy:

Furnace Serial Number \_\_\_\_\_

Furnace Model Number \_\_\_\_\_

Indoor Coil Serial Number \_\_\_\_\_

Indoor Coil Model Number \_\_\_\_\_

Date of Installation \_\_\_\_\_

Dealer \_\_\_\_\_

### Service Information

Call your installing dealer if the unit is inoperative. Before you call, always check the following to be sure service is required:

- a. Be sure the main switch that supplies power to the unit is in the ON position.
- b. Replace any burned-out fuses or reset circuit breakers.
- c. Be sure the thermostat is properly set.

Service Phone \_\_\_\_\_



American Standard  
Heating & Air Conditioning  
6200 Troup Hwy.  
Tyler, TX 75707