

IMPACT – Gas Furnace Operation

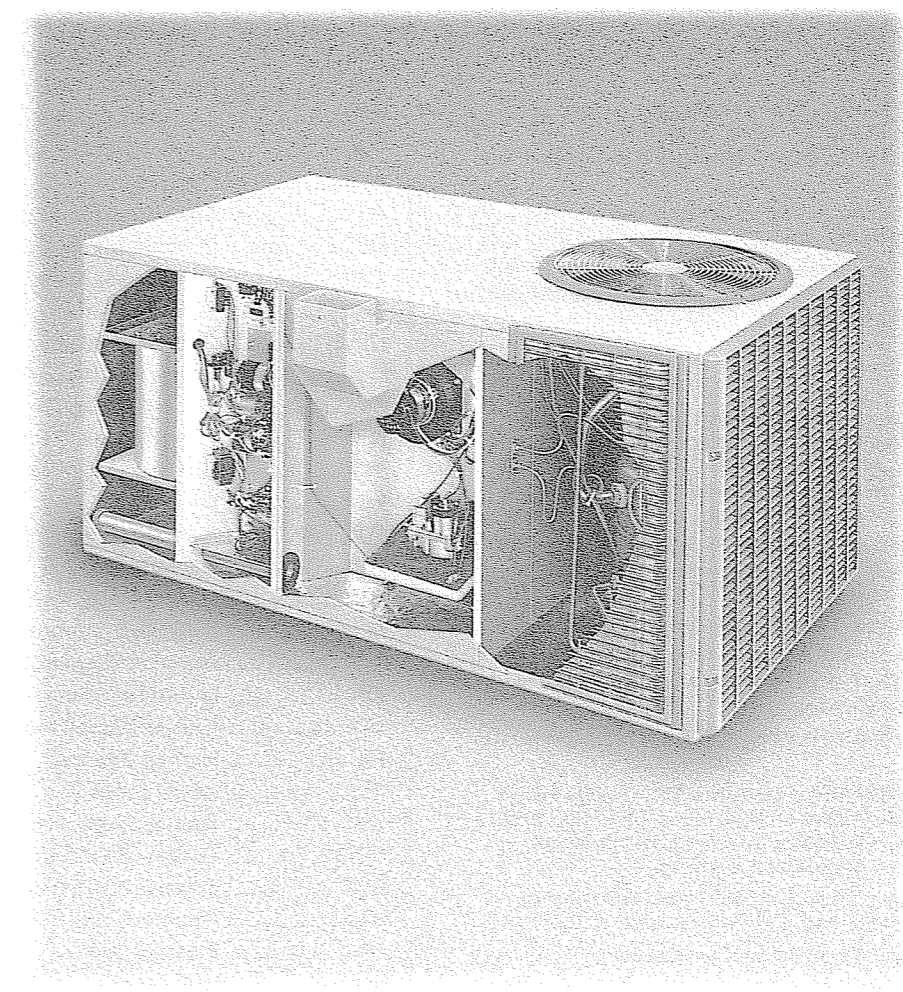

Model Nomenclature | Heating Sequence of Operation
Ignition Systems | Service/Troubleshooting

Literature Order Number		
File No.	Pub. No. 34-4056-05	10/04
Supersedes	Pub. No. 34-4056-04	4/01
Stocking Location		PI

Since the manufacturer has a policy of continuous product and product data improvement, it reserves the right to change design and specifications without notice.
© 2004 American Standard Inc. All rights reserved

Legend

Notes – YCC/YCX-F

- Connections shown are for typical thermostat. See schematic supplied with thermostat for proper connections. Low voltage wiring to unit may be NEC class 2 and must be a minimum of 18 A.W.G. Set thermostat heat anticipator to .3 Amps
- Maximum additional external load (Pilot Duty) between “B” and “R” of 0.5 Amps, 24 VAC is available in the cooling mode only.
- For 208 Volts operation make the following wiring changes:
 - At TNS1 move 1D(RD) from Red Wire and connect to Orange Wire. The Red Wire must be re-terminated to avoid accidentally shorting.
 - At IDM move 20A(RD) lead from FTBA-B to Yellow lead at CF2.
- If any of the original wire as supplied in this unit must be replaced, replace it with appliance wiring rated at 105°C.
- Indoor blower motor connections shown are for the YC*:024F1, -036F1 and -042F1 units. For indoor blower motor connections for the YC*:018F1 and -030F1 units see insets A and B.
- The compressor start capacitor, relay and wires are included in the YCX042F1 unit.
- For low speed fan requirements in the heating mode on the YCX024F1, -036F1 and -042F1 units only, move the 2H(BK) lead from FTBA-C to FTBA-D.

Notes – YCY-F

- Connections shown are for typical thermostat. See schematic supplied with thermostat for proper connections. Low voltage wiring to unit may be NEC class 2 and must be a minimum of 18 A.W.G. For single and two stage thermostat set the heat anticipator to .4 Amps
- Maximum additional external load (Pilot Duty) between “B” and “R” of 0.5 Amps, 24 VAC is available in the cooling mode only.
- For 208 Volts operation make the following wiring changes:
 - At TNS1 move 1D(RD) from Red Wire and connect to Orange Wire. The Red Wire must be re-terminated to avoid accidentally shorting.
 - At IDM move 20A(RD) lead from FTBA-B to Yellow lead at CF2.
 - At TNS2 move 11A(RD) wire from TNS2 Orange Wire and connect to Orange Wire on FU1. Move TNS2 Red Wire from FU1 and TNS2 Black Wire from FU2. Terminate all TNS2 Wires to prevent accidental shorting.
- If any of the original wire as supplied in this unit must be replaced, replace it with appliance wiring rated at 105°C.
- If ECM™ motor has internal thermal protection.
- If 100% airflow is required for fan only (“G” only), connect (BK) wire from ECMC-G1 to 47A(BK) wire from ECMC-G.
- If optional humidistat accessory is used, cut the (RD) loop and strip the leads. Connect the humidistat between the two (RD) leads. R and BK must be jumpered together is a humidistat is not used.
- The Green LED on the ECMC board flashes once per hundred CFM.

WIRE COLOR DESIGNATION			
ABBR	COLOR	ABBR	COLOR
BK	Black	PR	Purple
BL	Blue	RD	Red
BR	Brown	WH	White
GR	Green	YL	Yellow
OR	Orange		

DEVICE	DESCRIPTION
CC	Compressor Contact Coil
CCH	Crankcase Heater
CF1	Outdoor Fan Capacitor
CF2	Indoor Motor Capacitor
CF3	Combination Fan Motor Capacitor
CN	Connector or Wire Nut
CFM	Combustion Fan Motor
CPR	Compressor
CR	Compressor Run Capacitor
CS	Compressor Start Capacitor
CSR	Compressor Start Relay Coil
DFC	Defrost Control
DT	Defrost Terminator
F	Indoor Fan Motor Relay
FD	Flame Detector
FL	Fuseable Link
FTBA	Fan Terminal Block
FU	Fuse
FU1, FU2	Autotransformer Fuse
GV	Gas Valve
H	Heating Relay
ECM™	Integrated Commutated Motor
ECMC	Integrated Commutated Motor Control
IDM	Indoor Fan Motor
IGN	Ignition Control Module
IOL	Internal Overload
IP	Ignitor Probe
LED	Ignition Diagnostic Indicator
ODM	Outdoor Fan Motor
ODT	Outdoor Thermostat
PP	Polarized Plug
PS	Pressure Switch
RLB	Relay Board
SOV	Switchover Valve
TCO	Temperature Limit Switch
TDL	Temperature Defrost Limit
TNS1	Control Power Transformer
TNS2	CFM 230/208 Volt Autotransformer

NOTE: This publication is general in nature and is intended for INSTRUCTIONAL PURPOSES ONLY. It is not to be used for equipment selection, application, installation, or specific service procedures.

Demand Defrost Control Checkout

SYMPTOMS	CHECKS	YES/NO	ACTIONS
1. LED off.	1. 24V R-B & Y-B at board with unit running?	N	Repair low voltage wiring.
		Y	Complete Check #2.
	2. Move test wire to "forced defrost." Does control respond accordingly?	N	Replace defrost control.
		Y	LED is bad but control will still function.
2. LED flashing very rapidly (greater than 4 times/sec) or appears to be on continuously.	Test wire on "Test" position?	Y	Move test wire to "Normal."
		N	If test wire is on "Normal," replace defrost control.
3. Control does not initiate a normal defrost.	OD Temp. below 4°F. OD Coil temp. below 35°F? "Delta" T increasing?		
	1. LED flashing?	N	Refer to SYMPTOM #1.
		Y	Complete Check #2.
	2. Check for 24V Y-B at board with unit running.	N	Repair low voltage wiring.
		Y	Complete Check #3.
	3. Check sensors for correct mounting and resistance.		Remount or replace sensor if necessary.
4. Control does not initiate a forced defrost.	24V R-B & Y-B at board with unit running?	N	Repair low voltage wiring.
		Y	Replace defrost control.
5. Defrost initiates manually but terminates in less than 10 seconds.			Replace defrost control.
6. Defrost initiates manually but terminates on time.	1. Coil sensor circuit open or reading at a very high resistance?	Y	Replace coil sensor.
	2. Does OD fan cycle off in defrost?	N	Replace defrost control.
	3. Windy weather preventing normal termination?		
7. Defrost initiates on approximately 15/25 minute intervals.	Be sure OD coil is clean.		N Complete Check #2.
	1. Coil sensor open or reading a very high resistance?	Y	Replace coil sensor.
	2. Ambient sensor reading less than normal?	N	Complete Check #3.
		Y	Replace ambient sensor.
8. Defrost initiates on approximately 30/45 minute intervals.	1. Test wire on "Normal" pin?	N	Move to "Normal" pin.
		Y	Complete SYMPTOM #2.
	2. Do both sensors check OK?	N	Replace defective sensor (Clear coil and reset Emergency heat light).
		Y	Complete SYMPTOM #3.
	3. Verify correct system charge.		Adjust as needed.
	4. Verify a "forced defrost" terminates less than 15 minutes.		
5. OD fan motor off in defrost.		See SYMPTOM #9.	
6. Verify proper SOV operation.		Replace if necessary.	
9. OD fan runs during defrost.			Replace defrost control.
10. No SOV delay on defrost termination.			Replace defrost control.
11. Emergency heat light on constantly.	1. Emergency heat switch in normal position?	Y	Complete Check #2.
		N	Move switch to "Normal."
12. ODS-A burned out.	1. B to T greater than 10 volts?	Y	Check low voltage wiring for miswire.
		N	Check for short in low voltage wiring.

Flash Rate Indications:

- 1 – Flash/Second = Normal operation.
- 2 – Flashes/Second = Fault A (Low ΔT) i.e.: Inoperative compressor, loss of charge, open ambient sensor, shorted coil sensor.
- 3 – Flashes/Second = Fault B (10 defrosts terminated on time).
Fault C (High ΔT) i.e.: SOV stuck in heating, shorted ambient sensor, open coil sensor, closed TXV, OD motor failure, OD fan on in defrost, undercharged unit.
- 4 – Flashes/Second = Fault A & C or A & B

For additional information consult Pub. No. 34-1001 Heat Pump Defrost Controls.

Contents

Model Nomenclature	2
Firing Rate Selection – Single Stage Models	3
Manifold Pressure Settings	4
Gas Valves	5
Determining Natural Gas Furnace Input	6
Calculating CFM – Temperature Rise Method	6
Flame Rectification Principle – Measurement	7
White Rodgers 50D20 Spark Ignition Controls	8
White Rodgers Direct Spark Ignition Control Timing	9
YCC/YCX-F Sequence of Operation – White-Rodgers Spark Ignition	10
YCC/YCX-F Wiring Schematic – White-Rodgers Spark Ignition	11
DCX-F Dual Fuel Non-Restricted Operation – White-Rodgers Spark Ignition	12
DCX-F Dual Fuel Non-Restricted Wiring Schematic – White-Rodgers Spark Ignition	13
DCX-F Dual Fuel Restricted Operation – White-Rodgers Spark Ignition	14
DCX-F Dual Fuel Restricted Wiring Schematic – White-Rodgers Spark Ignition	15
Hamilton Standard Direct Spark Furnace Controls – (Introduced in August 1993)	16
Identifying Hamilton Standard Controls	17
Hamilton Standard Integrated Control Timing	18
Hamilton Standard Self Diagnostic Features	19
Hamilton Standard Abnormal Heating Operation – Pressure Switch Operation	20
Texas Instrument Direct Spark Furnace Controls	21
Identifying Texas Instrument Controls	22
Texas Instrument Integrated Control Timing	24
Texas Instrument Self Diagnostic Features	25
Texas Instrument Abnormal Heating Operation – Pressure Switch Operation	26
Demand Defrost System – Dual Fuel System Only	27
YCC/YCX-F Gas Electric Sequence of Operation – Hamilton Standard Single Stage CNT-1634	28
YCC/YCX-F Wiring Schematic – Hamilton Standard Single Stage CNT-1634	29
DCX-F Dual Fuel Non-Restricted Operation – Hamilton Standard Spark Ignition	30
DCX-F Dual Fuel Non-Restricted Wiring Schematic – Hamilton Standard Spark Ignition	31
DCX-F Dual Fuel Restricted Operation – Hamilton Standard Spark Ignition	32
DCX-F Dual Fuel Restricted Mode Wiring Schematic – Hamilton Standard Spark Ignition	33
YCY-F Two Stage Sequence of Operation – Hamilton Standard Spark Ignition	34
YCY-F Two Stage Wiring Schematic – Hamilton Standard Spark Ignition	35
5 Ton YCY-F Two Stage Sequence of Operation – Hamilton Std. Spark Ignition VS ECM™ Motor	36
5 Ton YCY-F Two Stage Wiring Schematic – Hamilton Standard Spark Ignition VS ECM™ Motor	37
YCC/YCX-F Gas Electric Sequence of Operation – Texas Instrument Single Stage CNT-2216	38
YCC/YCX-F Wiring Schematic – Texas Instrument Single Stage CNT-2216	39
DCX-F Dual Fuel Non-Restricted Operation – Texas Instrument Spark Ignition	40
DCX-F Dual Fuel Non-Restricted Wiring Schematic – Texas Instrument Spark Ignition	41
DCX-F Dual Fuel Restricted Operation – Texas Instrument Spark Ignition	42
DCX-F Dual Fuel Restricted Mode Wiring Schematic – Texas Instrument Spark Ignition	43
YCY-F Two Stage Sequence of Operation – Texas Instrument Spark Ignition	44
YCY-F Two Stage Wiring Schematic – Texas Instrument Spark Ignition	45
ECM™ Motor Control Boards	46
5 Ton YCY-F Two Stage Sequence of Operation – Texas Instrument Spark Ignition VS ECM™ Motor	48
5 Ton YCY-F Two Stage Wiring Schematic – Texas Instrument Spark Ignition VS ECM™ Motor – BRD0986	49
5 Ton YCY-F Two Stage Wiring Schematic – Texas Instrument Spark Ignition VS ECM™ Motor – CNT-1866	50

Contents – continued

Package Gas Electric ECM™ Motor Operation	51
ECM™ Control Input – Air Flow Priority and Dip Switches	52
ECM™ Quick Check – BRD0986	53
ECM™ Quick Check – CNT-1866	54
ECM™ Quick Check – CNT03600	55
Texas Instrument Integrated Furnace Controls	56
LitePort™ Software	57
Texas Instrument Self-Diagnostic Features	58
Identifying Texas Instrument Controls	59
Economizer	61
Gas Electric Sequence of Operation	62
Wiring Schematic	63
YCY-F Two Stage Sequence of Operation	64
YCY-F Two Stage Wiring Schematic	65
YCY-G Two Stage Sequence of Operation	66
YCY-G Two Stage Wiring Schematic	67
Demand Defrost Control Checkout	68

Model Nomenclature

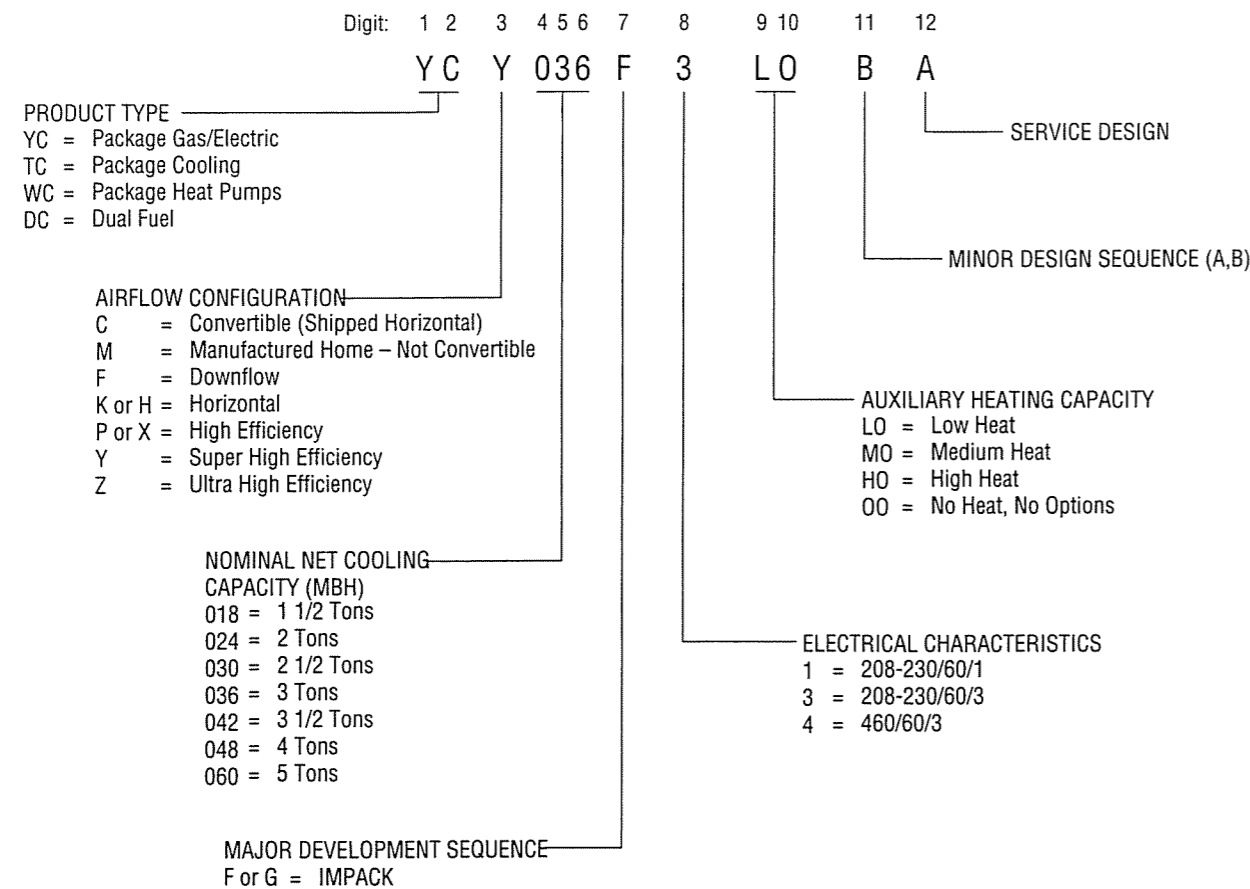

YCY-G Two Stage Wiring Schematic

Texas Instrument Spark Ignition Variable Speed ECM™ Indoor Motor – CNT-03458

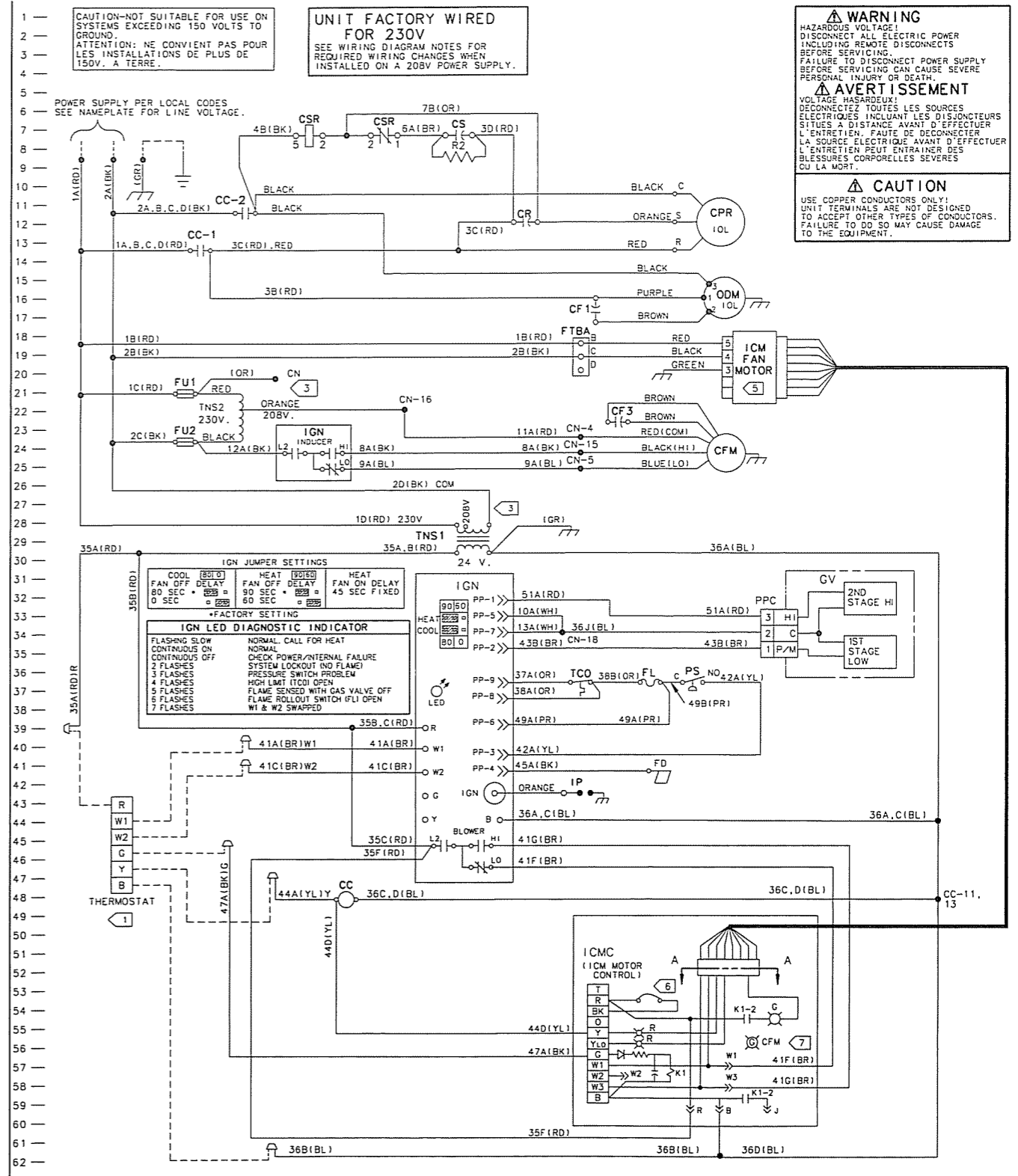

YCY-G Two Stage Sequence of Operation

Texas Instrument Spark Ignition Variable Speed ECM™ Indoor Motor

When the service disconnect ③ is in the "On" position, 230 volts is supplied from the line voltage input leads "L1" and "L2" ⑨ to the primary side of the low voltage control transformer (TNS1) ⑳⑲ and to terminals "4" and "5" of the ECM™ fan motor ⑱⑱. 24 volt power is supplied from the transformer secondary ⑳ to the ignition control (IGN) "R" and "B" terminals ㉑⑳. Power is also supplied to the "R" and "B" terminals ㉒⑳ of the indoor thermostat and to the "R" and "B" terminals of the ECMC motor control ㉓⑳. The green diagnostic L.E.D. ㉔ on the ignition control will light indicating that the control is receiving 24 volts and awaiting a call for heat.

On a first stage call for heat, 24 volt power will be supplied from the indoor thermostat "W1" terminal ㉕ to the "W1" terminal ㉖ of the ignition control (IGN). The ignition control will perform a self check routine and then check the limit switch (TCO) for normally closed contacts ㉗, the flame rollout fuseable link (FL) for continuity ㉘, and the pressure switch (PS) for normally open contacts ㉙.

With all safeties and switches in their proper position, the ignition control will open the normally closed inducer "LO" contacts and then close the normally open "L2" and "HI" inducer contacts ㉚ energizing the combustion fan motor (CFM) ㉛ on high speed for 15 seconds. As the combustion fan motor (CFM) comes up to speed, the control will verify that the pressure switch (PS) contacts ㉜ have closed and switch the combustion fan motor to low speed for a 5 second prepurge by opening the "HI" speed inducer relay contacts ㉛ and closing the "LO" speed inducer relay contacts ㉜.

The control will then simultaneously energize the spark ignitor probe (IP) ㉝ and supply 24 volts to terminals "1" and "2" on the gas valve ㉞⑳, energizing the first stage (low fire) of the gas valve ㉟.

The ignitor probe (IP) ㉝ will spark for a minimum of 2 seconds and a maximum of 7 seconds. Once the flame detector (FD) ㉞ senses a flame current signal of .5 microamps D.C. or greater, the ignitor (IP) will stop sparking and the 45 second heating fan on delay timer will begin. The ECM™ fan motor ㉛ will be energized after 45 seconds when the ignition control (IGN) closes the normally open "L2" blower relay contacts ㉛, supplying 24 volts through the normally closed "LO" indoor blower contacts ㉜, supplying 24 volts to the "W1" terminal of the ECMC motor control ㉝ energizing the ECM™ fan low heat speed.

With first stage operating, a second stage call for heat will supply power from the "W2" terminal of the thermostat ㉞ to the "W2" terminal of the ignition control ㉟. The combustion fan motor will switch to high speed as the "LO" speed inducer contacts open ㉛ and the normally open "HI" speed inducer relay contacts close ㉜. The second stage gas valve ㊱ will also be energized by supplying 24 volts to terminal "3" (HI) on the gas valve through "W2" on the ECMC board. The ECM™ fan ㉛ will be switched to "HI" after 30 seconds. The ignition controls normally open "LO" speed indoor blower relay contacts will open ㉛. The ignition control has sent a signal supplying 24 volts to the "W2" terminal on the ECMC motor control ㉝, the motor programming will energize the ECM™ fan on high heat speed.

When second stage is satisfied, the combustion fan motor (CFM) will be switched back to "low" speed and the 2nd stage gas valve ㊱ will be de-energized. The ECM™ fan motor will be switched back to low speed after 30 seconds. The unit will continue to operate in 1st stage operation as long as there is a call for heat.

Once first stage is satisfied, the 24 volt signal will be removed from the "W1" terminal of the ignition control ㉖. The first stage gas valve will close, instantly stopping gas flow to the burners. The flame detector will sense the loss of flame current and begin the 5 second combustion fan motor post purge, and the 60 or 90 second heating fan off delay timer. The "L2" inducer relay contacts will open ㉛ after the 5 second post purge de-energizing the combustion fan motor. The "L2" blower relay contacts ㉛ will open, de-energizing the ECM™ fan motor after the 60 or 90 second heating fan off delay period.

Firing Rate Selection – Single Stage Models

All of the IMPACK single stage gas electric units are shipped from the factory for use with natural gas. The factory installed #42 drill gas orifices are sized to deliver 25,000 BTUH per burner. If a lower input is desired, #44 drill gas orifices are provided to reduce the firing rate to 20,000 BTUH per burner ①. An outlet flue restrictor is also required when the firing rate is lowered. The #44 drill orifices and outlet flue restrictor plate are located in a bag attached to the gas manifold in the burner compartment.

Low Input Orifice Installation

Remove the presently installed gas orifices and replace with gas orifices shipped with the unit. The orifice should extend 1/4 inch out of the manifold for burner support.

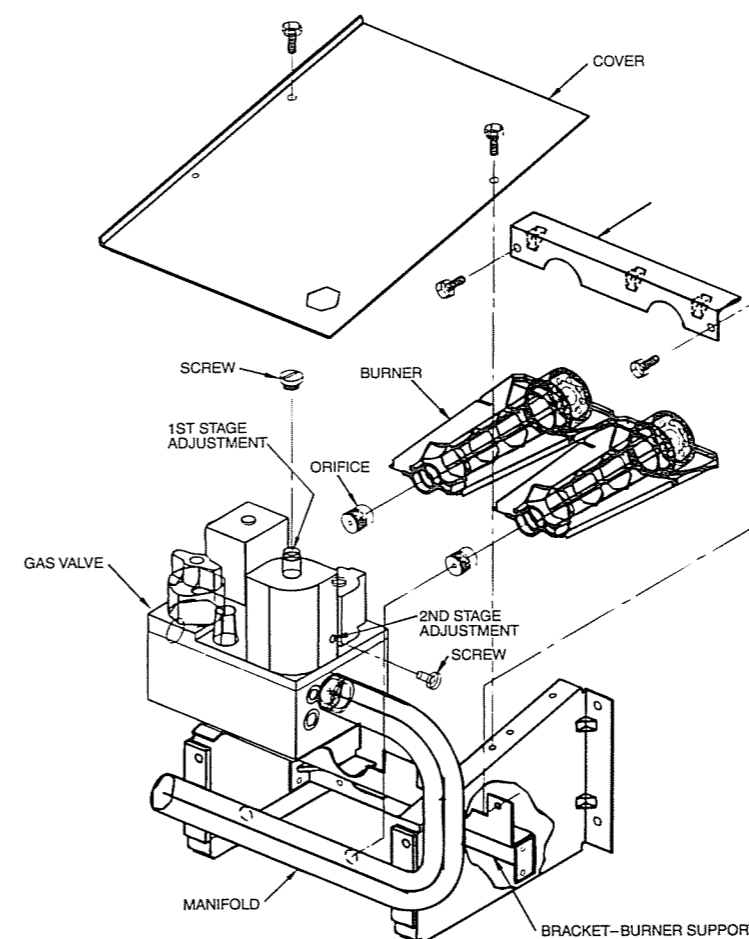

Low Input Flue Restrictor Plate Installation

The outlet flue restrictor is required when the furnace is operated on low input. To install the outlet flue restrictor, remove the top access panel and fit the outlet flue restrictor over the outlet of the flue duct. Reassemble the top access panel onto unit.

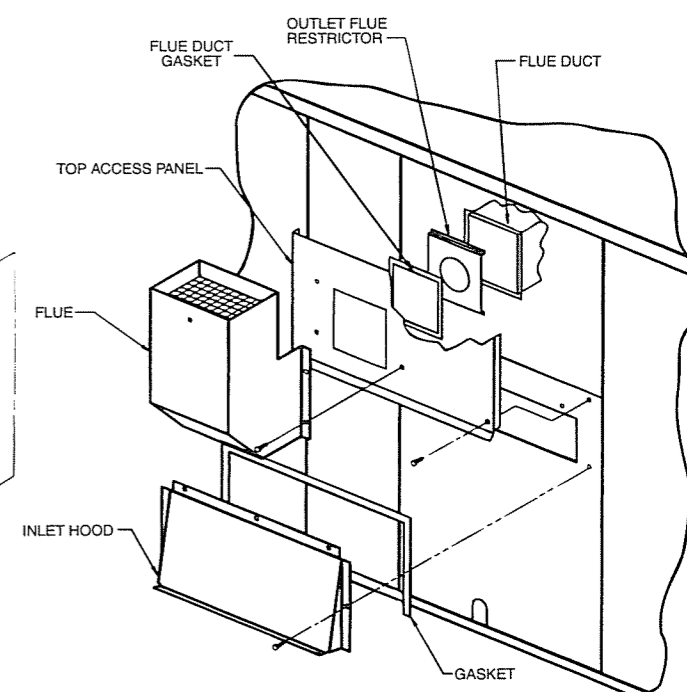

① Units built prior to 3rd quarter 1993 were shipped out for low input and orifices were provided for high input conversion.

Manifold Pressure Settings

The IMPACK units are shipped from the factory for use with natural gas. Conversion to propane requires a change in the main burner orifices. The two stage gas valve used in the YCY-F and G models perform the following.

It is necessary to adjust the "Hi" fire setting to maximum rate (turn adjustment screw clockwise until it bottoms) before setting the "Lo" propane fire rate, otherwise the "Lo" fire rate of 6.1" W.C. cannot be set above the 3.6" W.C. natural gas "Hi" fire setting.

MAIN BURNER ORIFICE DRILL SIZE 0-2000 FT. ALTITUDE	TYPE FUEL	FINAL MANIFOLD PRESSURE SETTING	
		1ST STAGE (YCY-F)④	2ND STAGE①
42③	NATURAL⑤	1.7" W.C	3.6" W.C.
54	PROPANE⑥	6.1" W.C②	10.0"-10.3" W.C.

- ① Applies to single stage models also.
- ② YCY036F-H, YCY042F-M - 6.9" W.C.
- ③ 25,000 BTUH per burner (as shipped).

- ④ 1st stage is approximately 75-80% of HI fire.
- ⑤ Minimum supply pressure 7" W.C.
- ⑥ Minimum supply pressure 11" W.C.

ORIFICE TABLE

SIZE	PART NUMBER	DESCRIPTION	SIZE	PART NUMBER	DESCRIPTION
#43	ORF00409	N/G 2,000-6,000 FT.	#45	ORF00644	N/G 6,000-8000 FT.
#44	ORF00501	N/G LOW FIRE ORIFICE	#55	ORF00693	L/P 2,000-4,500 FT.

YCY-F Two Stage Wiring Schematic

Texas Instrument Spark Ignition Standard Indoor Fan Motor - CNT-03457

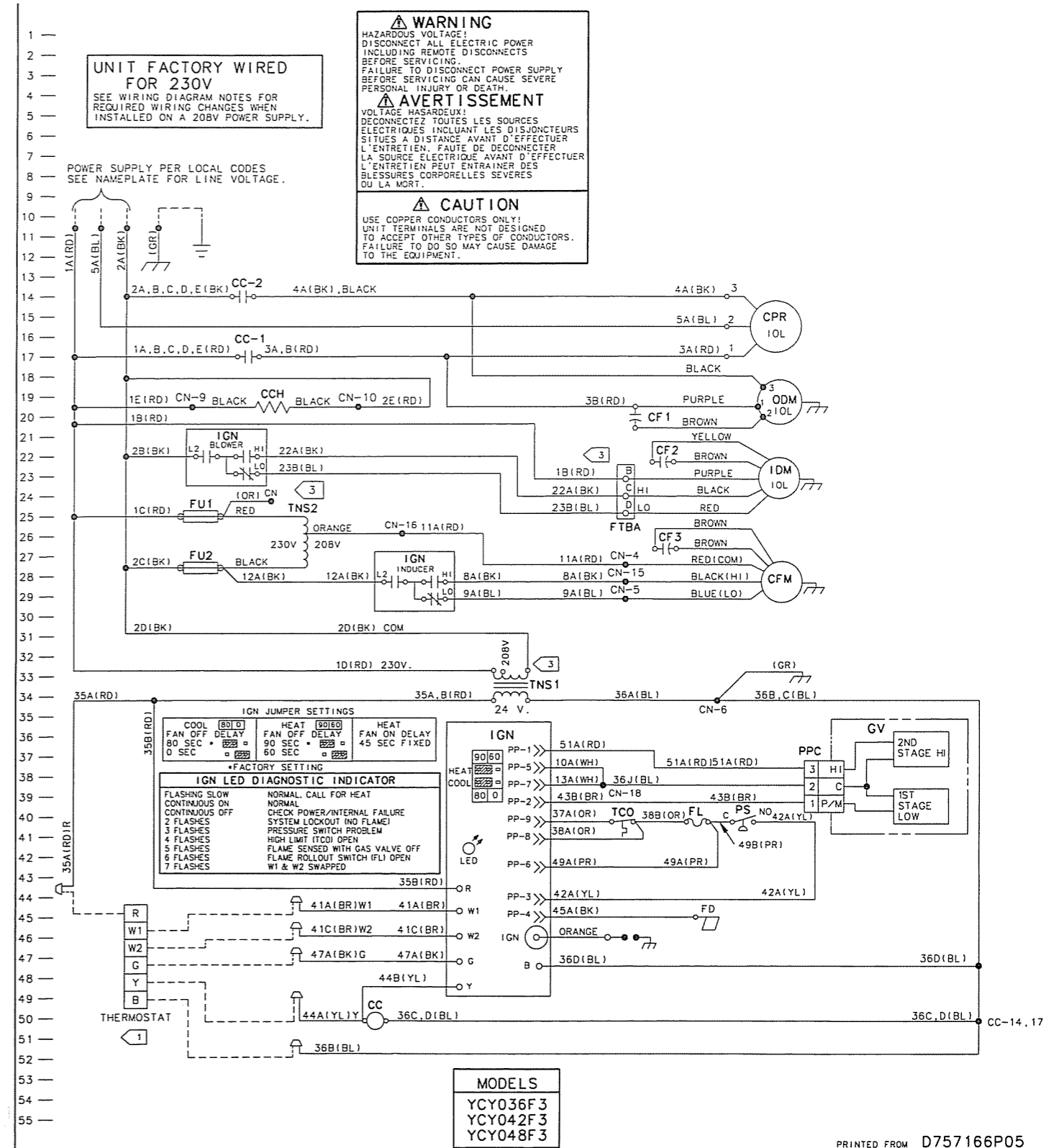

YCY-F Two Stage Sequence of Operation

Texas Instrument Spark Ignition – Standard Indoor Fan Motor

When the service disconnect ⑫ is in the “on” position, 230 volts is supplied from the line voltage input leads “L1” and “L3” ⑬ to the primary side of the low voltage control transformer (TNS1) ⑬⑭. 24 volt power is supplied from the transformer secondary ⑮ to the ignition control (IGN) “R” and “B” terminals ⑮⑯. Power is also supplied to the “R” and “B” terminals ⑮⑯ of the indoor thermostat. The green diagnostic L.E.D. ⑰ on the ignition control will light indicating that the control is receiving 24 volts and awaiting a call for heat.

On a first stage call for heat, 24 volt power will be supplied from the indoor thermostat “W1” terminal ⑰ to the “W1” terminal ⑮ of the ignition control (IGN). The ignition control will perform a self check routine and then check the limit switch (TCO) for normally closed contacts ⑳, the flame rollout fuseable link (FL) for continuity ㉑, and the pressure switch (PS) for normally open contacts ㉒.

With all safeties and switches in their proper position, the control will open the normally closed inducer “LO” contacts ㉓ and then close the normally open “L2” and “HI” inducer contacts ㉓ energizing the combustion fan motor (CFM) ㉔ on high speed for 15 seconds. As the combustion fan motor (CFM) comes up to speed, the control will verify that the pressure switch (PS) contacts ㉒ have closed and switch the combustion fan motor to low speed for a 5 second prepurge by opening the “HI” speed inducer relay contacts ㉓ and closing the “LO” speed inducer relay contacts ㉓.

The control will then simultaneously energize the spark ignitor probe (IP) ㉕ and supply 24 volts to terminals “1” and “2” on the gas valve ㉖⑳, energizing the first stage (low fire) of the gas valve ㉖.

The ignitor probe (IP) will spark for a minimum of 2 seconds and a maximum of 7 seconds. Once the flame detector (FD) ㉗ senses a flame current signal of .5 microamps D.C. or greater, the ignitor (IP) will stop sparking and the 45 second heating fan on delay timer will begin. The indoor blower motor (IDM) ㉘ will be energized after 45 seconds when the control closes the normally open “L2” blower relay contacts ㉓, supplying 230 volts through the normally closed “LO” blower contacts ㉓ to the “LO” speed winding of the indoor blower motor ㉘.

With first stage operating, a second stage call for heat will supply power from the “W2” terminal of the thermostat ㉙ to the “W2” terminal of the ignition control ㉕. The combustion fan motor will switch to high speed as the “LO” speed inducer contacts open ㉓ and the normally open “HI” speed inducer relay contacts close ㉓. The second stage gas valve ㉗ will also be energized by supplying 24 volts to terminal “3” ㉚ on the gas valve. The indoor blower motor ㉘ will be switched to “HI” speed after 30 seconds. The normally open “HI” speed blower relay contacts ㉓ will close and the “LO” speed blower contacts will open ㉓.

When second stage is satisfied, the combustion fan motor (CFM) will be switched back to “Low” speed and 2nd stage gas valve ㉗ will be de-energized. The indoor blower motor will be switched back to low speed after 30 seconds. The unit will continue to operate in 1st stage operation as long as there is a call for heat.

Once first stage is satisfied, the 24 volt signal will be removed from the “W1” terminal of the ignition control ㉕. The first stage gas valve will close, instantly stopping gas flow to the burners. The flame detector will sense the loss of flame current and begin the 5 second combustion fan motor post purge, and start the 60 or 90 second heating fan off delay timer. The “L2” inducer relay contacts will open ㉓ after the 5 second post purge period, de-energizing the “LO” speed combustion fan motor. The “L2” blower relay contacts ㉓ will open, de-energizing the low speed indoor blower after the 60 or 90 second heating fan off delay period.

Gas Valves

Single Stage Models (YCC, YCP, YCX, DCX, DCY)

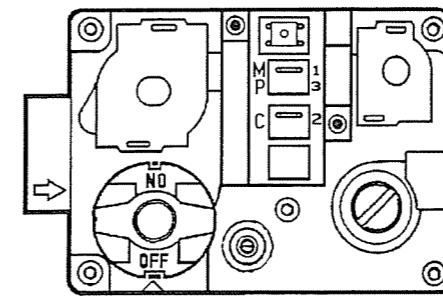

- White-Rodgers 36E36-252 VAL-3339
- Propane Regulator Spring KIT-1401
- Natural Regulator Spring KIT-1402

Single Stage Toggle Switch

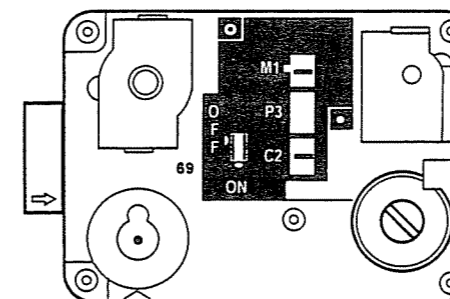

- White-Rodgers 36E22-213 VAL06526
- Propane Regulator Spring KIT02851
- Natural Regulator Spring KIT-1402

Single Stage Toggle Switch

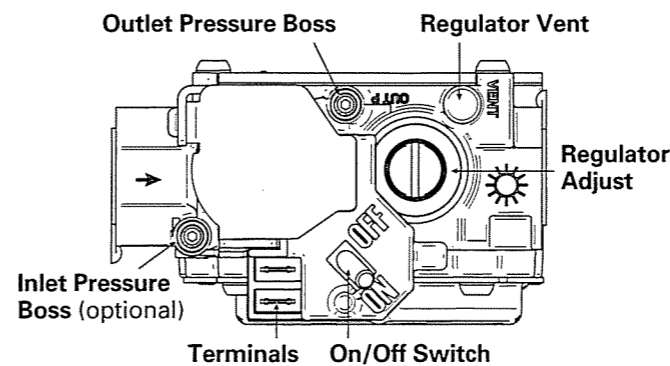

- Gas Valve VAL07973
- LP Kit BAYLPKT022A
- LP Kit with Stainless Steel Burners ... BAYLPKT001A

Two-Stage Models (YCY-F/G)

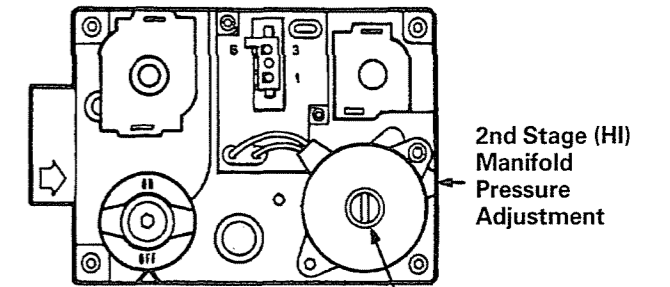

- White-Rodgers 36E96-228 VAL-4360
- Dual Purpose Valve (Natural or Propane)

Two-Stage with Toggle Switch

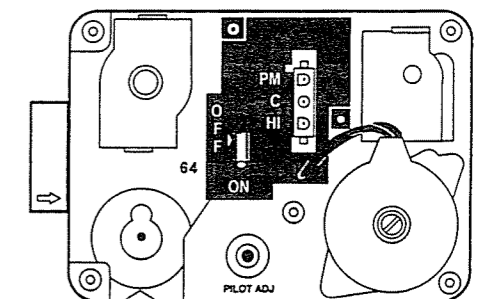

- White-Rodgers 36E54-209 VAL06527
- Dual Purpose Valve (Natural or Propane)

Two-Stage with Toggle Switch

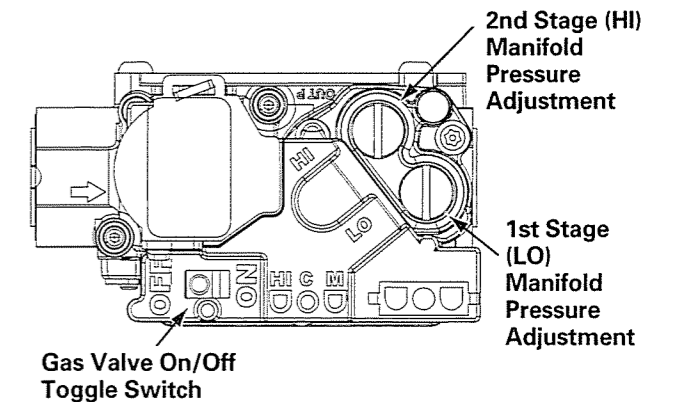

- Gas Valve VAL08237
- LP Kit BAYLPKT024A
- LP Kit with Stainless Steel Burners ... BAYLPKT002A

Determining Natural Gas Furnace Input

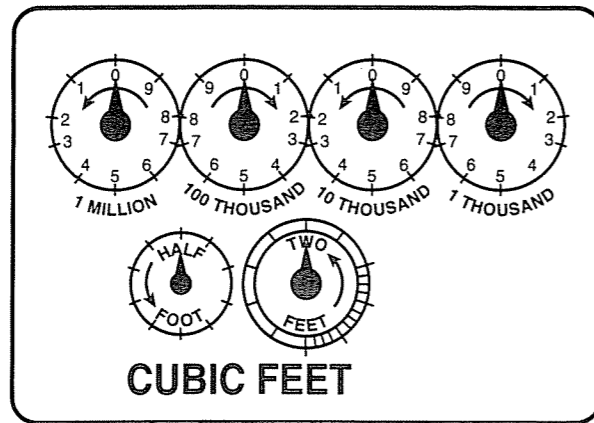

- Measure the time taken for two revolutions of the two cubic foot dial.
- Call gas supplier for BTU/Cu.Ft. Heating value of gas

- or -

- Use 1000 BTU/Cu.Ft. as value (If specific value not available)
- * Heating value of gas based on sea level pressure.

- Calculate Input:

$$\text{Cu.Ft./Hour} = \frac{\text{Revolutions} \times \text{Cu.Ft./Revolution} \times 3600}{\text{Time (In Seconds)}}$$

$$\text{BTUH} = \text{Cu.Ft./Hour} \times \text{BTU/Cu.Ft.}$$

Important: Input should never exceed 100% of rated input. Adjust manifold pressure or change main orifice size if required

Calculating CFM – Temperature Rise Method

$$\text{CFM} = \frac{\text{BTUH (Output)}}{\Delta T \times 1.08}$$

Minimum steady state efficiency – 80%

– Use AFUE if over 80%

$$\text{BTUH (out)} = \text{BTUH (in)} \times \frac{\text{Efficiency}}{100}$$

Example:

- BTUH (in) = 75,000
- AFUE = 80%
- BTUH (out) = 75,000 x .80 = 60,000

• $\Delta T = 45^\circ$

$$\text{CFM} = \frac{60,000}{45 \times 1.08} = 1235$$

Wiring Schematic

Texas Instrument Single Stage Spark Ignition – CNT-03456

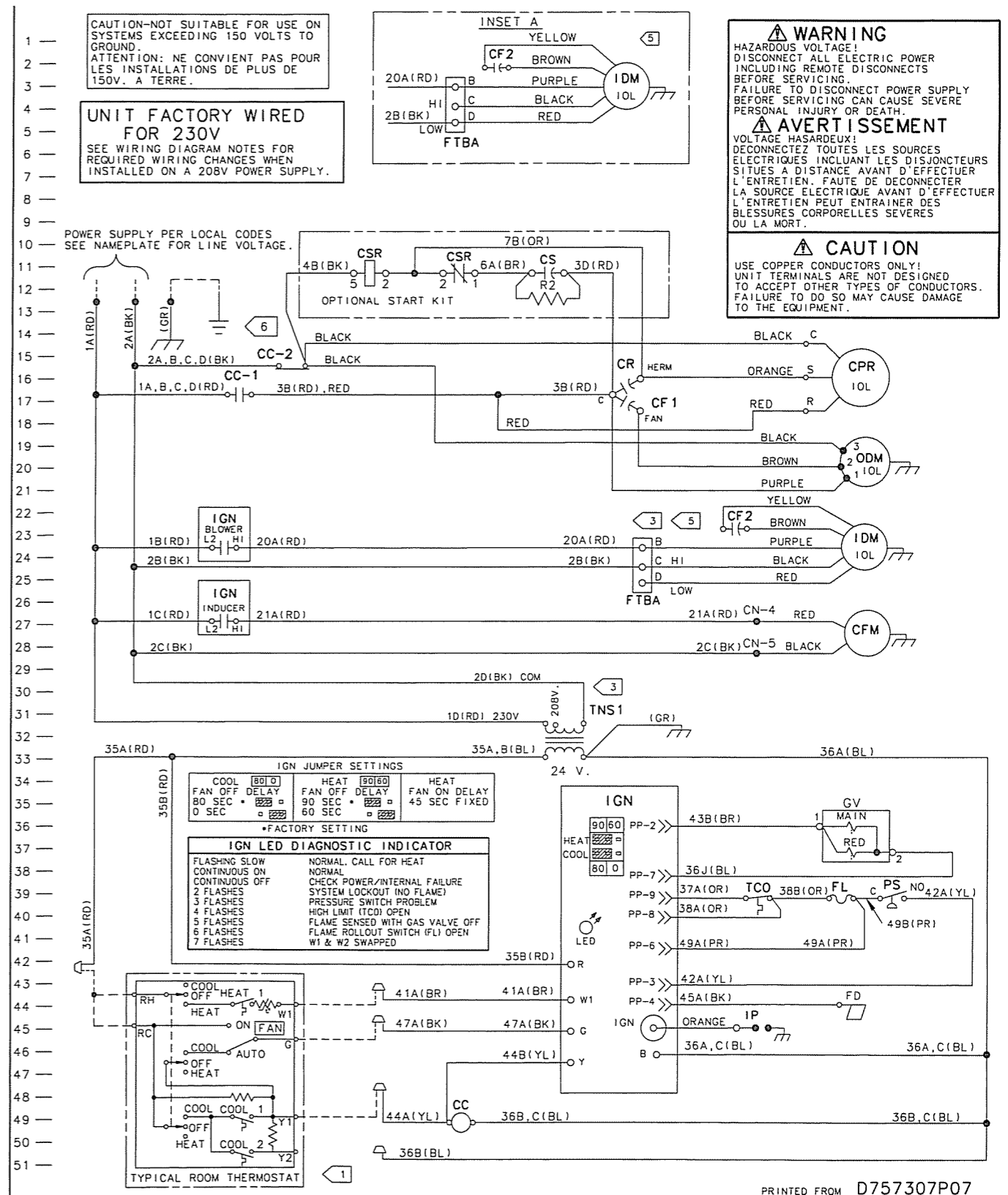

Gas Electric Sequence of Operation

Texas Instrument Single Stage Spark Ignition – CNT-03456

When the service disconnect ⑫ is in the “on position”, 230 volts is supplied from the line voltage input leads “L1 and L2” ⑬ to the primary side of the low voltage control transformer (TNS1) ⑭. 24 volt power is supplied from the transformer secondary ⑮ to the ignition control (IGN) “R” and “B” terminals ⑯⑰. Power is also supplied to the “RC” and “RH” terminals of the indoor thermostat ⑱. The green diagnostic L.E.D. ⑲ on the ignition control will light indicating that the control is receiving 24 volts and awaiting a call for heat.

On a call for heat, the indoor thermostat contacts “Heat-1” ⑳ will close. 24 volt power will be supplied from the thermostat “W1” terminal ㉑, to the “W1” terminal on the ignition control ㉒.

The ignition control will perform a self-check routine and then check the limit switch (TCO) for normally closed contacts ㉓, the flame roll-out fuseable link (FL) for continuity ㉓, and the pressure switch (PS) for normally open contacts ㉓.

With all safeties and switches in their proper position, the control will close the inducer relay contacts ㉔, energizing the combustion fan motor (CFM) ㉔. The green diagnostic L.E.D. ⑲, will also begin flashing once per second (slow flash) indicating a call for heat.

As the combustion fan motor (CFM) ㉔ comes up to speed, the normally open pressure switch contacts (PS) ㉓ will close. The control will initiate a 15 second combustion fan motor prepurge. After the prepurge the control will energize the spark ignitor probe (IP) ㉕ and the main gas valve (GV) ㉖.

The ignitor probe (IP) ㉕ will spark for a minimum of 2 seconds and a maximum of 7 seconds. Once the flame detector (FD) ㉗ senses a flame current signal of 1.2 microamps or greater, the ignitor will stop sparking and the 45 second heating fan on delay timer will begin. The indoor blower motor (IDM) will be energized at the end of the 45 second fan delay when the normally open “L1” and “IGN” blower contacts close ㉘, supplying 230 volts to the indoor blower motor.

When the thermostat is satisfied, the “Heat 1” contacts ㉑ will open, removing power from the “W1” terminal on the ignition control (IGN) ㉒. The main gas valve (GV) ㉖ will close instantly stopping gas flow to the burners. The flame detector (FD) ㉗ will sense the loss of flame current and begin the 5 second combustion fan motor postpurge ㉔ and the 60 or 90 second heating fan off delay. The heating fan off delay is field selectable by setting the dip switches on the ignition control ㉒.

IGNITION TABLES				
DIP SWITCH SETTINGS			LED DIAGNOSTIC INDICATOR	
Cool Fan OFF	Heat Fan OFF	Heat Fan ON	Flashing Slow	Normal. Call For Heat
Delay (Seconds)	Delay (Seconds)	Delay (Seconds)	Continuous ON	Normal
SW2 OFF 0	SW1 OFF 60	Fixed 45	Continuous OFF	Check Power/Internal Flame
SW2 ON 80*	SW1 ON 90*		2 Flashes	System Lockout (No Flame)
			3 Flashes	Pressure Switch Problem
			4 Flashes	High Limit (TCO) Open
			5 Flashes	Flame Sensed With Gas Valve Off
			6 Flashes	Flame Rollout Switch (FL) Open
			7 Flashes	W1 & W2 Swapped
*Factory Setting				

Flame Rectification Principle – Measurement

The White-Rodgers, Hamilton Standard and Texas Instrument controls use the flame rectification principle to prove that flame is present after the gas valve has been energized.

The flame rectification principle is based on the fact that a flame can conduct electrical current. When a positive charge is placed on the flame sensor and a flame is present to complete the circuit from the burner surface or ground, current will flow from the burner ground (zero potential) through the flame to the flame sensor which has a greater positive charge.

The ignition control will sense the current flow and allow the gas valve to remain open and the heating cycle to continue. The flame current is monitored by the ignition control and will shut down the gas valve if the minimum flame sense current is not present for more than .8 seconds.

The White-Rodgers integrated furnace controls require a minimum of 1.0 micro amps DC to prove flame. The Hamilton Standard controls require a minimum of .5 micro amps D.C. The Texas Instrument controls require a minimum of .5 micro amps D.C.

The flame current microamp signal must be checked as part of regular maintenance and during normal service checks in order to properly diagnose the ignition system.

The flame current microamp signal can be measured with many of the new digital volt OHM meters. However, there are many digital meters which do not have **microamp scales** but can read DC volts.

The flame current is measured by removing the flame sensor wire at the flame sensor and connecting it to one of the meter leads. The other meter lead is connected to the flame sensor.

A flame current adapter for digital volt meters, Pub. No. 34-4816-01, see below, is available which allows flame current microamps to be measured on the DC volt scale. The adapter has two leads with a male and female quick connect for easy hook up to the flame sensor.

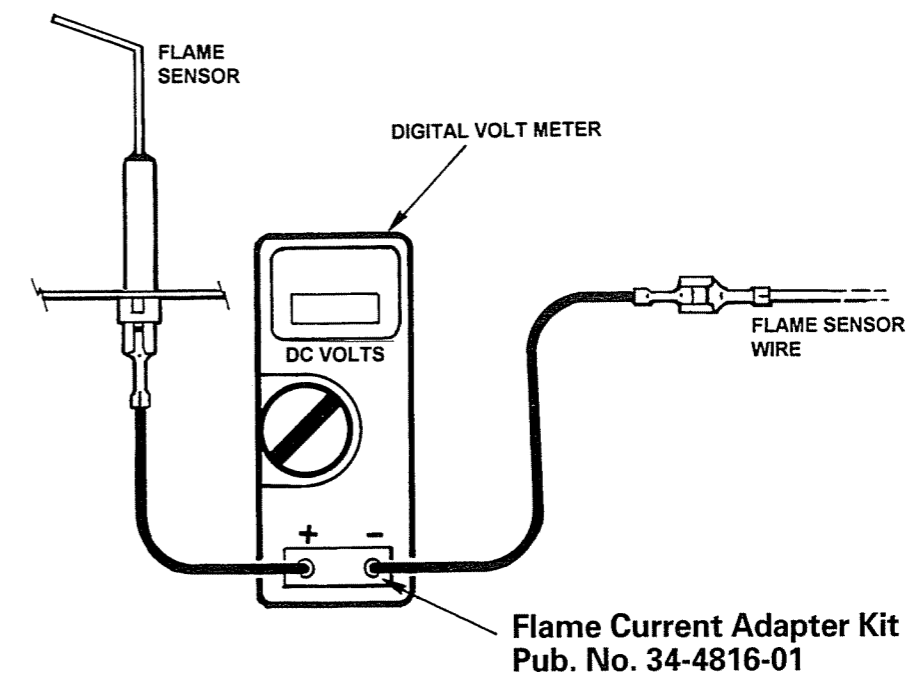

White Rodgers 50D20 Spark Ignition Controls

The White Rodgers 50D20 direct spark ignition control was used on initial production of the IMPACK gas electric units. The 50D20 control provides the ignition source for the multi-port inshot burners. Remote flame sensing is used to confirm ignition and safe operation of the gas burners. The remote flame sensor is located on the far left hand burner and the gas is ignited by the spark ignitor on the far right hand burner. This arrangement proves that all burners have lit. The control will lockout after three tries if flame current is not sensed. If flame is sensed for at least ten seconds, the retry counter is reset and three more attempts can be made before locking out.

The control has a thirty second pre-purge before each ignition cycle to ensure adequate combustion airflow. There is also a sixty second inter-purge or delay between trials for ignition. This allows any unburned gasses time to dissipate before the next ignition attempt begins.

The control also features built in self diagnostic capability. The LED will flash one time at the start of each cycle indicating that the control is functional. The control will begin flashing the red LED should a lockout occur due to external problems such as loss of flame signal. The LED will stay on continuously should an internal control fault be detected.

Diagnostic LED

- Flashing LED – Control Locked out due to external problem.
- Continuous LED – Internal Control Failure – Replace module

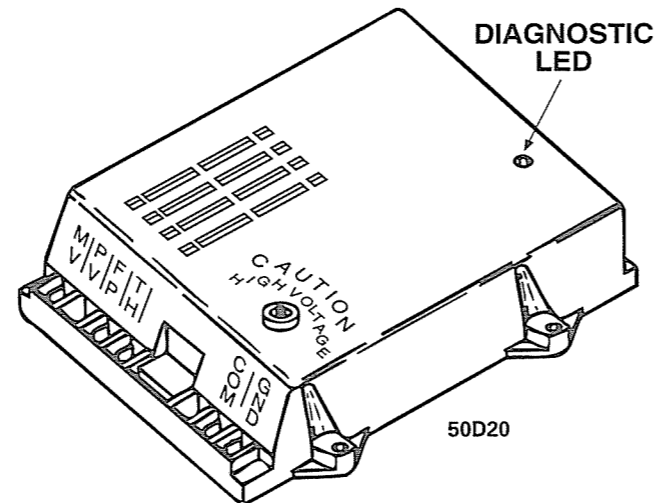

Note: Always try to reset the control by interrupting power before replacing control.

Economizer

The economizer accessory, used with the Impack line of conditioning products, allows the use of outdoor air for conditioning, when the conditions outside are suitable. By utilizing a control capable of measuring the temperature and humidity of this air, the economizer determines whether or not to open the damper allowing the outside air to enter the equipment. This Enthalpy control is the brain of the economizer.

Significant savings in operating costs may be realized by properly setting the control to stop the compressor, in the cooling mode of operation, and allowing

the outside air to provide the cooling required. If the outdoor air contains excess moisture, it is easy to see that this would defeat the desired result. Therefore, the control must also be set to the desirable level of moisture content or humidity.

Commercial applications are most likely to receive this benefit as residential applications do not usually provide ventilation.

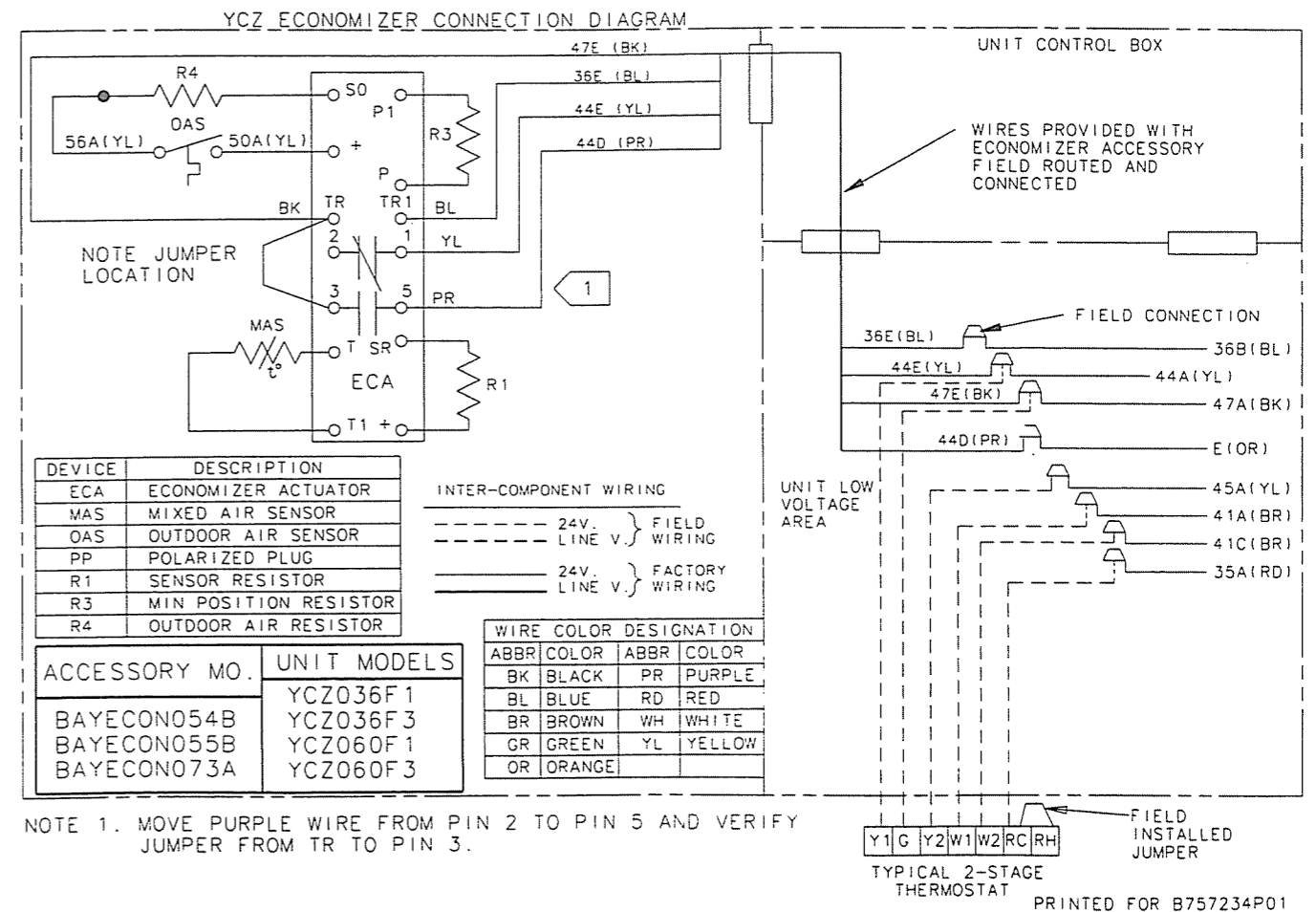

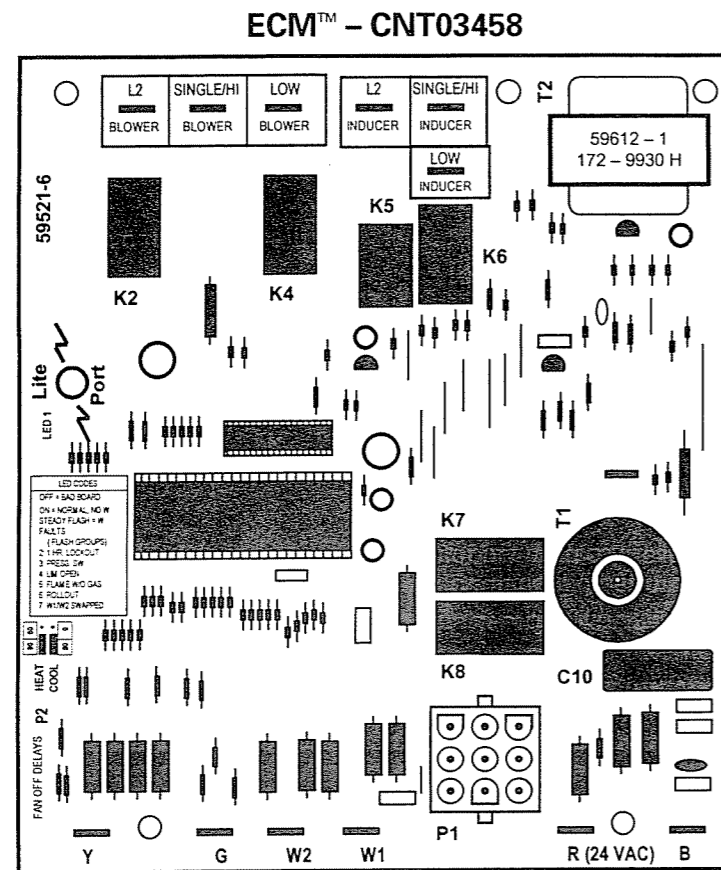

Combustion Fan Motor

Pre-purge	30 seconds
Post purge	0 seconds
Re-try interpurge	60 seconds (plus 30 seconds pre-purge)

Ignition Control

Minimum flame current	1.0 micro amps DC.
Normal flame current	3 to 5 micro amps DC
Trial for ignition (spark time)	2 second minimum, 7 second maximum
Spark voltage ^①	25,000 volts
Flame failure response	.8 seconds
Ignition retries (before lockout) ^②	2 after initial try (3 total)
Ignition recycles (loss of flame) ^③	4 (5 total)

Notes:

- ① Early production controls had 3 short bursts of spark with a flame sense check in between each burst. Current versions have a continuous spark for the full seven second trial period.
- ② If flame current is sensed on or before the third attempt, the re-try counter will be reset and three more attempts can be made.
- ③ If flame is sensed for ten seconds, the recycle counter will be reset and four more recycles can be made.

Service Tip: Controls with date codes prior to 9141 were susceptible to electrical noise and may cause the diagnostic LED to glow continuously indicating a control failure. The control and spark ignitor high voltage lead routing were modified to prevent nuisance lockouts from occurring due to electrical noise.

YCC/YCX-F Sequence of Operation

White-Rodgers Spark Ignition

When the service disconnect ⑪ is in the "ON" position, 230 volts is fed to the primary side of the control transformer ⑳ from the line voltage input leads "L1" and "L2" ⑮. 24 volt control voltage is supplied from the secondary side of the control transformer ⑳ to the "RC" and "RH" terminals of the indoor thermostat ㉔.

On a call for heat, the indoor thermostat contacts "HEAT 1" close ㉔. 24 volts is supplied from the "W1" terminal on the thermostat ㉔ to the "H" relay solenoid ㉑ and to the open side of the safety pressure switch (PS) ㉕. When the "H" relay solenoid ㉑ energizes, "H" relay contacts ㉖ close completing the 230 volt circuit to the combustion fan motor ㉗. Once the combustion fan motor comes up to speed, the safety pressure switch (PS) ㉕ will close completing the 24 volt circuit through the temperature cut out (TCO) ㉙ and the flame roll-out fuse link (FL) ㉚ to the ignition control terminal "TH" ㉛ starting the ignition sequence. The ignition sequence begins with a 30 second combustion fan motor pre-purge cycle. After the pre-purge cycle is complete, the ignition control (IGN) switches 24 volts to the gas valve "GV" ㉜, ㉝ through its "MV" terminal ㉞ and at the same time energizes the high voltage spark probe "IP" ㉟ through its "IGN" terminal ㊱ for a burner ignition attempt. Once the burner is lit, the control senses the presence of flame through the "FP" terminal ㉞. The control will de-energize the spark probe 2 seconds after sensing flame.

If burner flame is not sensed by the ignition control (FP) ㉞ within 8 seconds of the gas valve being energized, the ignition control will de-energize the gas valve and the high voltage spark probe and start a 90 second combustion fan motor purge cycle. This allows for the removal of any unburned gas that may be present in the heat exchanger before another ignition attempt. After the interpurge cycle is complete, the ignition control will again energize the gas valve and the ignition probe in an attempt to light the burners. If the ignition control does not sense the presence of flame within the 8 second lockout period, the control will repeat the interpurge and ignition attempt a third time before locking out.

When the burners light, the thermal fan switch (FS) ㉚ senses radiant heat from the heat exchanger tubes as they heat up causing the thermal fan switch contacts to switch to the "HOT" position and complete a 24 volt circuit to the "F" relay solenoid ㉚. The "F" relay solenoid energizes, causing the "F" relay contacts ㉛ to close, completing a 230 volt circuit to the indoor blower motor (IDM) ㉛. The indoor blower motor is energized supplying warm air to the space.

NOTE: It takes approximately 30 seconds for the thermal fan switch (FS) to change from the cold to the hot position.

When the thermostat satisfies, its "HEAT 1" contacts ㉔ open breaking the circuit to the "H" relay ㉑ and the ignition control ㉛. The gas valve ㉜ is de-energized and the combustion fan motor ㉗ stops. The indoor blower motor will continue to run until the thermal fan switch "FS" changes to the "COLD" position ㉚, de-energizing the "F" relay solenoid ㉚ and breaking the circuit to the indoor blower motor through its "F" contacts ㉛.

Identifying Texas Instrument Controls/LitePort™ Models

Single Stage – CNT0346

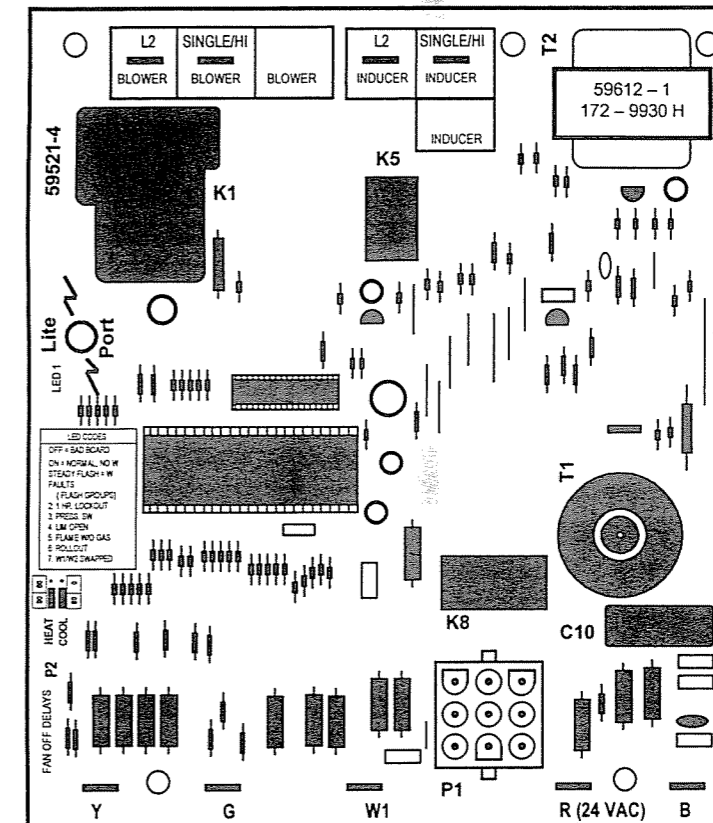

Two Stage – CNT03457

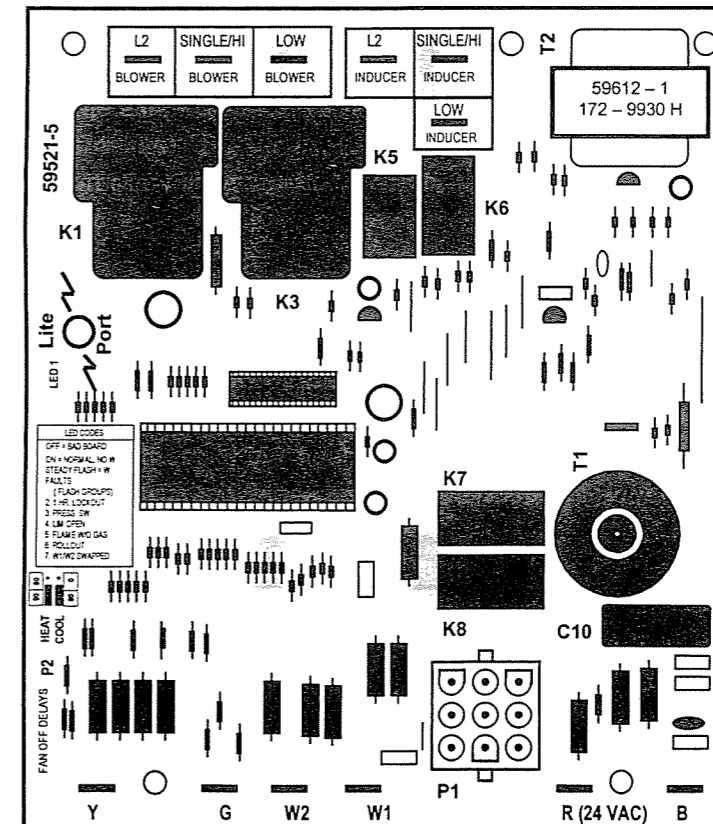

LitePort™ Reporting Capabilities

The Texas Instrument integrated furnace control circuitry used in controls CNT0346, CNT03457 and CNT03458 is similar to the circuitry in previously used controls, in that it has system fault analysis and the ability to quickly shut off gas flow along with the ability to automatically restart the ignition system when the fault is no longer detected. The control microprocessor is continually monitored by a "watchdog" circuit to prevent transient voltages (electrical interference) from causing no heat calls due to internal latch-up of the microprocessor.

Upon a call for heat, the furnace control will perform an "internal" and "external" check for faults before allowing an ignition sequence to begin.

The internal check confirms that the computer software and watchdog circuits are working properly. The external checks include all safety devices and pressure switches, making sure they are in their proper "normally open" or "normally closed" position for the start of an ignition cycle. If the control detects a fault upon a call for the heat, the GREEN diagnostic LED will begin flashing a rate according to the type of fault detected (see GREEN LED Diagnostic table below) until the fault is corrected.

Visual Diagnostics On The New Board (Green LED)	
LED Flash	Indicates
Steady OFF	No Power/Failure/Internal Failure.
Steady ON	Normal.
Slow Flash	Normal, call for heat. Wink off.
2 Flashes	System lockout – no flame. Total of three tries. Automatic reset in one hour.
3 Flashes	Pressure switch error. (Fault may be caused by a vent problem or a wiring connection in the switch circuit.)
4 Flashes	High limit switch protection device open.
5 Flashes	Flame being sensed with gas valve de-energized (stuck open) or flame sensed and no "W" signal.
6 Flashes	Flame rollout switch open.
7 Flashes	Thermostat miswire; W1 and W2 swapped.

Important: Diagnostics flash rates will be reset if power is interrupted to the ignition control or primary power is turned off. Always check the flash rate before turning off the power!

If a fault is detected during normal heating operation, the gas valve will be de-energized immediately and the green diagnostic LED will begin flashing at the rate for the type of fault detected.

The single and two-stage controls will automatically reset a lock-out fault due to the loss of flame current every two hours as long as continuous call for heat exists from the thermostat.

The integrated controls can be reset manually by interrupting the 24 volt signal to the ignition control for longer than three seconds.

The minimum flame current for the single and two-stage controls is .5 micro-amps DC. The typical flame current signal during normal operation will vary from 3.0 to 6.0 micro-amps DC.

White-Rodgers Spark Ignition

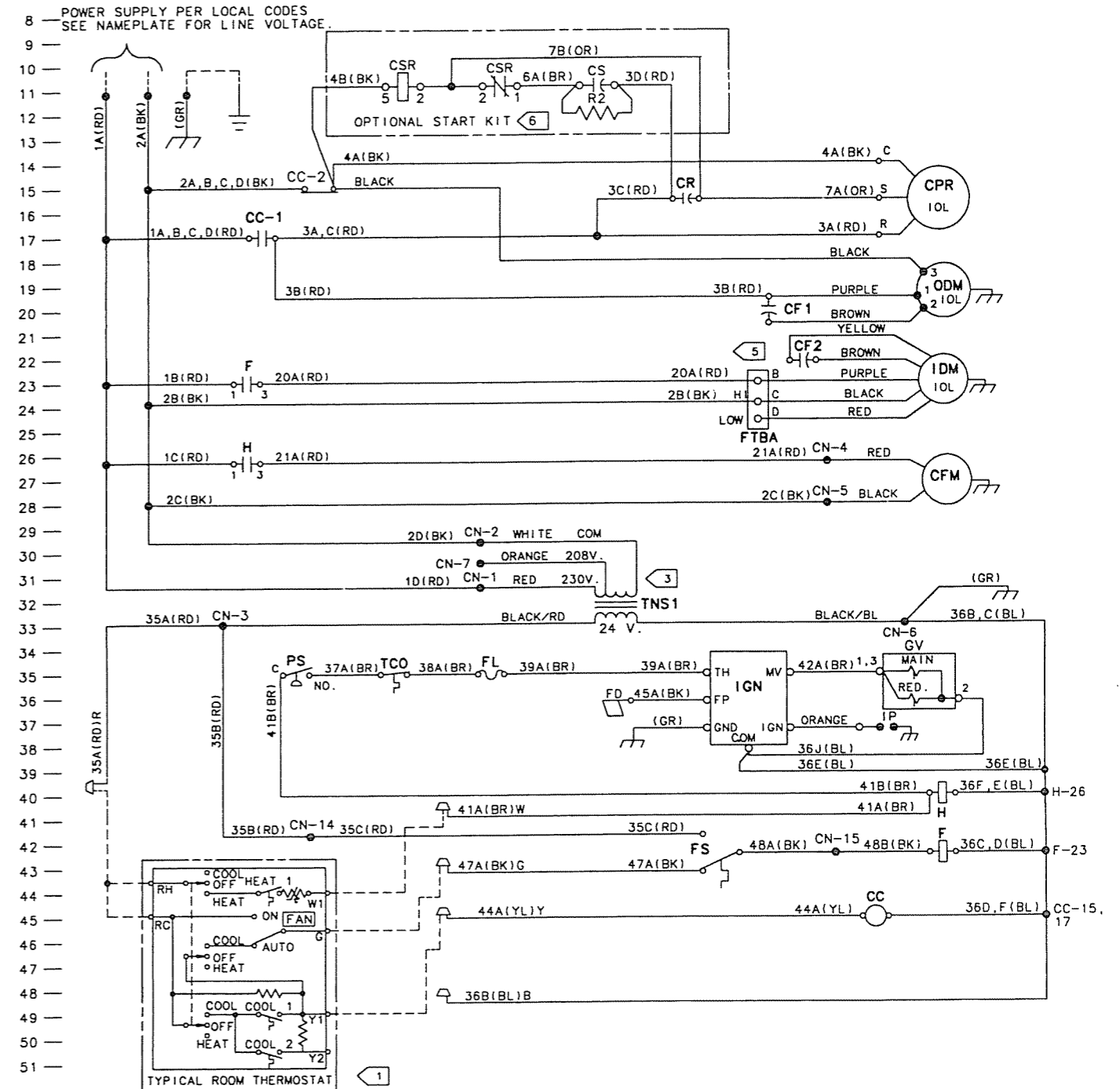

DCX-F Dual Fuel Non-Restricted Operation

White Rodgers Spark Ignition

Non-Restricted Mode (as shipped from the factory)

During non-restricted operation, the heat pump will be operated during a first stage call for heat. Upon a second stage heat call, the heat pump is cut off and the gas heat is operated until both stages of heat are satisfied. Heat pump operation will resume upon the next first stage call for heat.

Non-Restricted Sequence of Operation

Upon a first stage call for heat, 24 volts from the indoor thermostat "Y" terminal ⑤ will be supplied through the normally closed K3 relay contacts (Terminals 1 and 2) to the compressor contactor coil (cc) ⑩, closing the CC-1 contacts ⑩, energizing the compressor (CPR) ⑧ and outdoor fan motor (ODM) ⑬. 24 volt power will also be supplied from the thermostat "G" terminal ⑤ to the fan relay coil (F) ③⑤ through the normally closed K3 relay contacts on the RLB (Terminals 4,5) ③⑤ and the thermally operated fan limit switch ③⑦.

The normally open fan relay contacts will close ③⑦ energizing the indoor blower motor. First stage heat pump operation is now running.

When the temperature drops 1-1/2 degrees there will be a second stage call for heat. 24 volt power will be supplied from the thermostat "W" terminal ③⑦ through the relay board normally closed "K2" relay contacts (terminals 1, 2) ③②③⑤ to the heating relay coil (H) ③④ and the normally open pressure switch contacts ③②.

The normally open heat relay contacts will close ③② energizing the combustion fan motor (CFM) ③② as the combustion fan motor comes up to speed, the combustion air pressure switch (PS) contacts ③② will close supplying 24 volt through the fan limit and TCO safety controls ③② to the "TH" terminal of the ignition control. The normal heating sequence will now occur. At the same time, 24 volts is supplied through the normally closed K1 relay contacts (terminals 1,2) (47) on the relay board to the "W" terminal on the relay board ③⑤ energizing the "K3" relay. The normally closed "K3" relay contacts will open (terminal 1, 2) ③⑤, breaking the 24 volt "Y" signal to the compressor contactor coil (cc) ⑩, de-energizing the compressor and outdoor fan motor. The normally closed K3 relay contacts (terminals 4, 5) will open, breaking the 24 volt "G" signal to the fan relay coil (F), de-energizing the indoor blower motor. The indoor motor will be energized when the thermally operated fan switch contacts transfer to the warm position ③⑤ supplying 24 volts to the fan relay coil ③⑤. The normally open "K3" relay board contacts (terminals 1, 3) ③⑤ are now closed, locking in the second stage "W" gas heating circuit under control of the first stage (compressor, "Y") heating call on the thermostat.

Emergency Heat Mode

In restricted or non-restricted mode, 24 volts will be supplied from "X2" on the indoor thermostat ④⑨ to the heat relay coil ③③ initiating a call for gas heating operation. The gas heat is controlled by the first stage of the thermostat (TSH-1) ③④. The thermostat system switch (RHS-1) ③⑤ disconnects the "Y" circuit when moved to the "emergency heat position".

LitePort™ Software

Impack Gas/Electric Diagnostic Software

For models YCZ, YCY, YCX, YCP and YCC.
Available with or without optical probe.

- Analyze Heating Faults with LitePort™ or by Fault LED
- Service Procedures Heating Video
- Refrigeration Diagnosis for Impack/R-22 Systems Only
- Charging and Performance



PC Only

Software with Standard Probe Pub. No. 34-3426-01
Software with Battery Operated Probe Pub. No. 34-3426-BP
Software only Pub. No. 34-3426-SW

Pocket PC Only

Software with Standard Probe Pub. No. 34-3422-01
Software with Battery Operated Probe Pub. No. 34-3422-BP
Software only Pub. No. 34-3422-SW

Furnace Diagnostic Software

For models *UY, *DY, *UXR and *DXR.
Available with or without optical probe.

PC Only

Software with Standard Probe Pub. No. 34-3441-01
Software with Battery Operated Probe Pub. No. 34-3441-BP
Software only Pub. No. 34-3441-SW

Pocket PC Only

Software with Standard Probe Pub. No. 34-3427-01
Software with Battery Operated Probe Pub. No. 34-3427-BP
Software only Pub. No. 34-3427-SW

Residential Heat Pump Diagnostic Software*

Available with or without optical probe.

PC Only

Software with Standard Probe Pub. No. 34-3425-01
Software with Battery Operated Probe Pub. No. 34-3425-BP
Software only Pub. No. 34-3425-SW

Pocket PC Only

Software with Standard Probe Pub. No. 34-3424-01
Software with Battery Operated Probe Pub. No. 34-3424-BP
Software only Pub. No. 34-3424-SW

*LitePort™ not available for two compressor units.

Optical Probe Only

Probe – Can be used with PC or Pocket
PC/Serial Port Connector Pub. No. 34-3422-LP

Battery Powered Probe* – Can be used with
PC or Pocket PC/Serial Port Connector Pub. No. 34-3440-01

*For Pocket PC or PCs that do not provide power to operate the optical probe.

Order through your distributor

Texas Instrument Integrated Furnace Controls

The construction and mounting of the new controls is a change from previously used controls from Texas Instrument. The controls are mounted to the frame of the equipment by an insulated mounting board or "backplane". The connections are made through a pigtail having ten wires. This is a change in both the mounting and wire harness connection.

These controls will be used in replacement form as kits. The kit will consist of the control, the mounting board and the harness, which converts the wire connections to accommodate the different wiring plug. This will allow the new kits to replace older controls as needed. The mounting bracket will mount in place of the existing control.

The kits will use only two of the controls. The single stage control will not be used in replacement. The two-stage control senses the presence or absence

of the second gas valve operator and automatically controls the operation of the furnace. The second control in kit form is the one used with the ECMC control for the variable speed indoor blower motor. See the table for the correct replacement kit.

Kit Information

KIT06839 uses CNT03457 to replace both single-stage and two-stage controls CNT2216 and CNT2217.

KIT06840 uses CNT03458 to replace variable speed indoor blower model CNT2219.

The timing and indicators are not the same on the original and the replacement controls. Read the material in this training manual to familiarize yourself with the changes to avoid mis-diagnosis of potential faults.

DCX-F Dual Fuel Non-Restricted Wiring Schematic

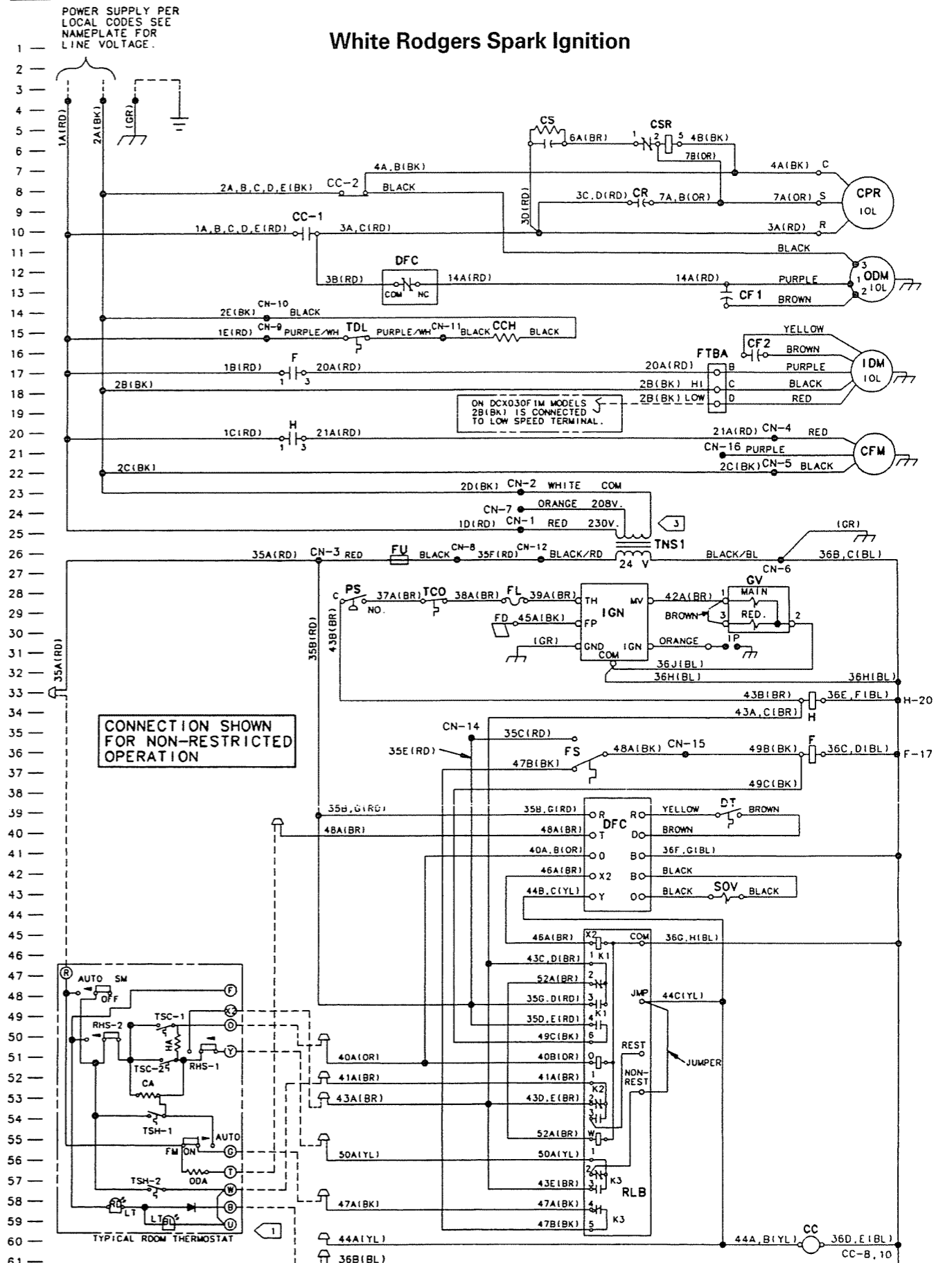

See Legend on Inside Front Cover

DCX-F Dual Fuel Restricted Operation

White Rodgers Spark Ignition

Restricted Mode (requires outdoor thermostat)

During restricted mode of operation, the heat pump and gas furnace are controlled by the first stage of the indoor thermostat. **The second stage of the indoor thermostat (W) is not connected during restricted operation.** The first stage heating call (Y) is circuited through an outdoor thermostat (BAYSTAT033A) that will operate the heat pump when above the outdoor thermostat setting and operate the gas heat when below the outdoor thermostat setting.

Note: Factory jumper wire must be moved to restricted terminal on relay board.

Sequence of Operation

Upon a first stage call for heat, 24 volts is supplied from the "Y" terminal on the indoor thermostat (51) to the common terminal, (terminal 2) of the outdoor thermostat (ODT) (63). If the outdoor ambient temperature is above the setting of the ODT (warm position), 24 volts will be supplied to terminal 1 of the ODT (61), energizing the compressor contactor (CC) (60), starting the compressor and outdoor fan motor. The first stage heat call will also energize the "G" circuit energizing the fan relay (F) (36) starting the indoor fan motor.

If the outdoor ambient is below the ODT setting (cold position), 24 volts will be supplied to terminal 3 of the ODT (63), supplying 24 volts to the heat relay (H) (33) initiating a call for gas heat operation. The gas heat will operate until the first stage of the thermostat is satisfied or the outdoor thermostat (ODT) switches to the warm position, de-energizing the gas heat circuit and switching the unit back to heat pump operation.

Defrost Sequence – Restricted Mode

The defrost control (DFC) (39) initiates a defrost and energizes the switchover valve (43) and supplies 24 volts to the "O" terminal on the relay board (51) energizing the "K2" relay. The normally open K2 relay contacts (Terminals 1, 3) (52/54) will close, connecting the "Y" circuit to terminal 3 (63) of the outdoor thermostat. Should the outdoor thermostat switch to the cold position during a defrost cycle, the compressor "Y" circuit will be locked in until the defrost cycle is complete.

ECM™ Quick Check – BRD03600

Blower Motor Will Not Run

1. Jumper 24 Volt A.C. wire #35A Red to wire #47A Black in the units Low Voltage (thermostat junction box).

Does motor run?

No: Go to step number 2.

Yes: Motor runs, check thermostat and thermostat wire.

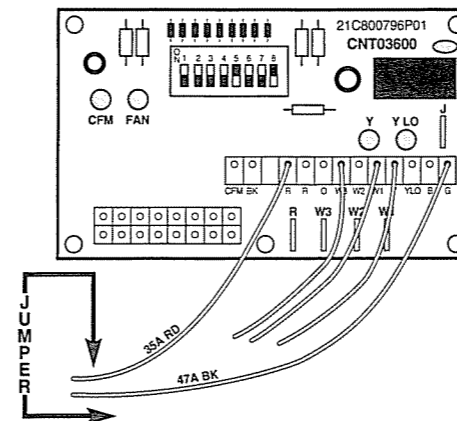

Package Unit Motor Control Board (ECMC)

2. Unplug 16 wire low voltage harness from the motor control board. Jumper 24 Volts A.C. to pins number 12, number 15 and common pins number 1 and number 3.

Does the motor run?

No: Go to step number 3.

Yes: Replace the motor control board..

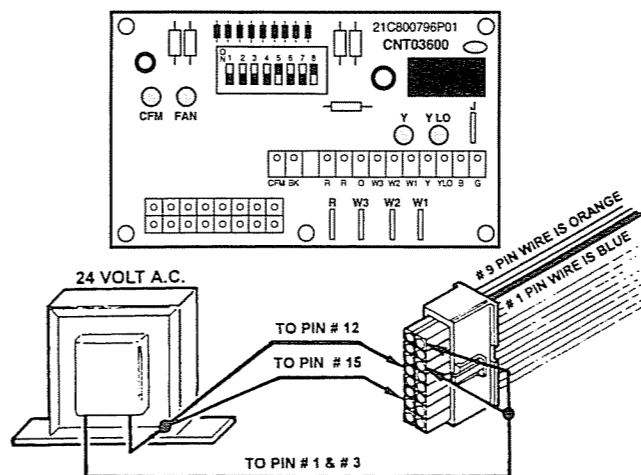

3. Unplug 16 wire low voltage harness from the motor. Jumper 24 Volts A.C. to motor low voltage plug pins number 12 and number 15 and pins number 1 and number 3 which are common.

Does motor run?

No: Go to step number 4.

Yes: Fault is in the 16 wire low voltage harness. Repair or replace it.

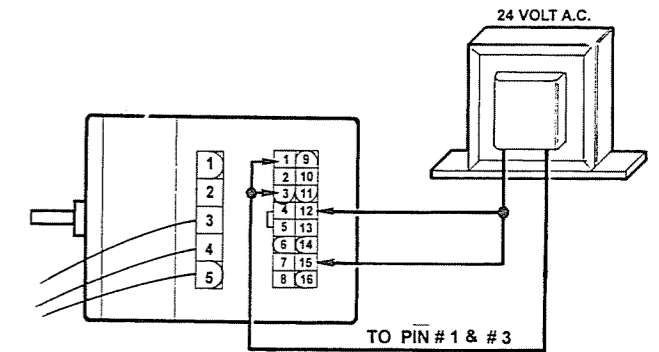

4. Is the line voltage to the motor high voltage power plug pin number 4 and pin number 5 correct?

Package unit ECM™ motor correct voltage is 220 volts A.C.

No: Correct line voltage fault.

Yes: Line voltage correct and motor will not run. Replace motor module.

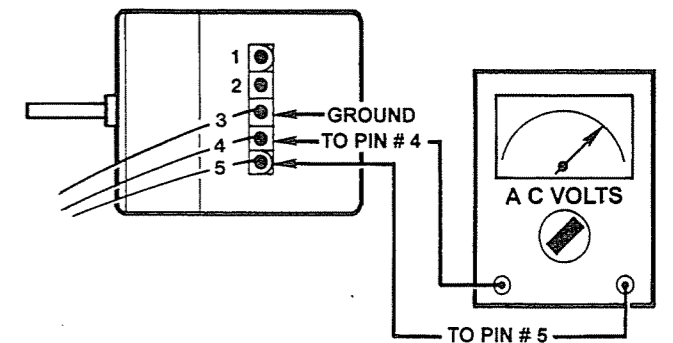

ECM™ Quick Check - CNT 1866

Blower Motor Will Not Run

1. Jumper 24 Volt A.C. "R" terminal to "G" terminal on the Low Voltage Terminal board.

Does motor run?

No: Go to step number 2.

Yes: Motor runs, check thermostat and thermostat wire.

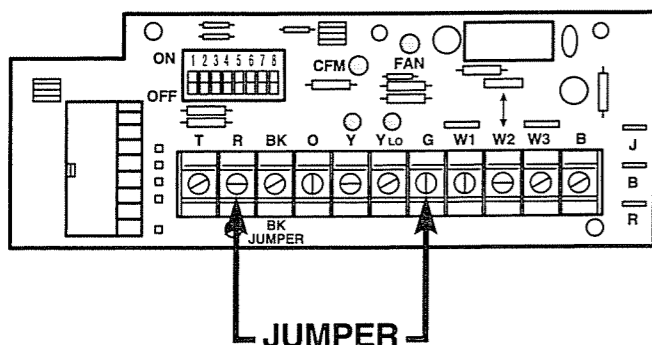

Package Unit Motor Control Board (ECMC)

2. Unplug 16 wire low voltage harness from the motor control board. Jumper 24 Volts A.C. to pins number 12, number 15 and common pins number 1 and number 3.

Does the motor run?

No: Go to step number 3.

Yes: Replace the motor control board..

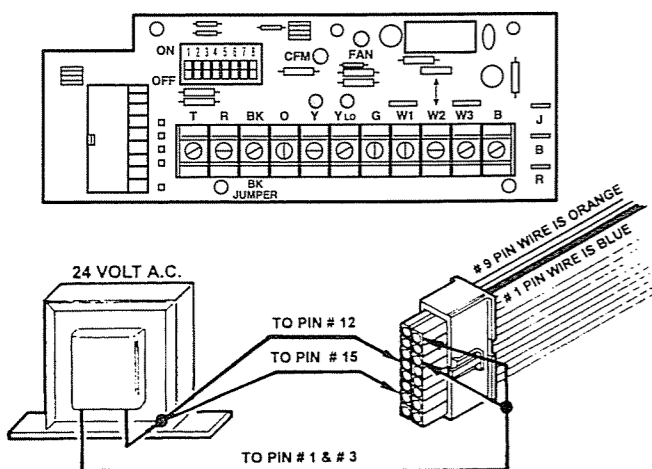

3. Unplug 16 wire low voltage harness from the motor. Jumper 24 Volts A.C. to motor low voltage plug pins number 12 and number 15 and pins number 1 and number 3 which are common.

Does motor run?

No: Go to step number 4.

Yes: Fault is in the 16 wire low voltage harness. Repair or replace it.

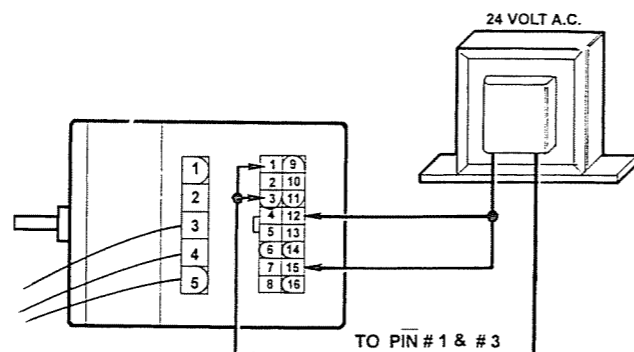

4. Is the line voltage to the motor high voltage power plug pin number 4 and pin number 5 correct?

Package unit ECM™ motor correct voltage is 220 volts A.C.

No: Correct line voltage fault.

Yes: Line voltage correct and motor will not run. Replace motor module.

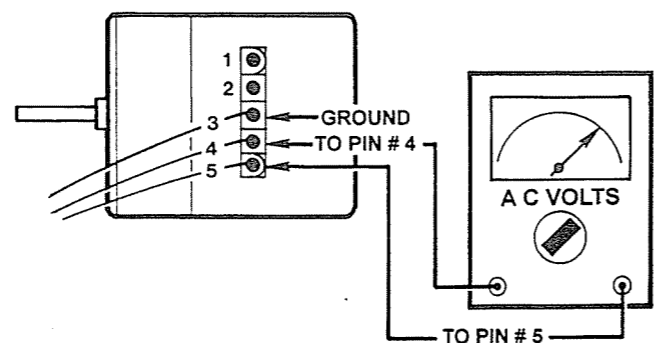

DCX-F Dual Fuel Restricted Wiring Schematic

White Rodgers Spark Ignition

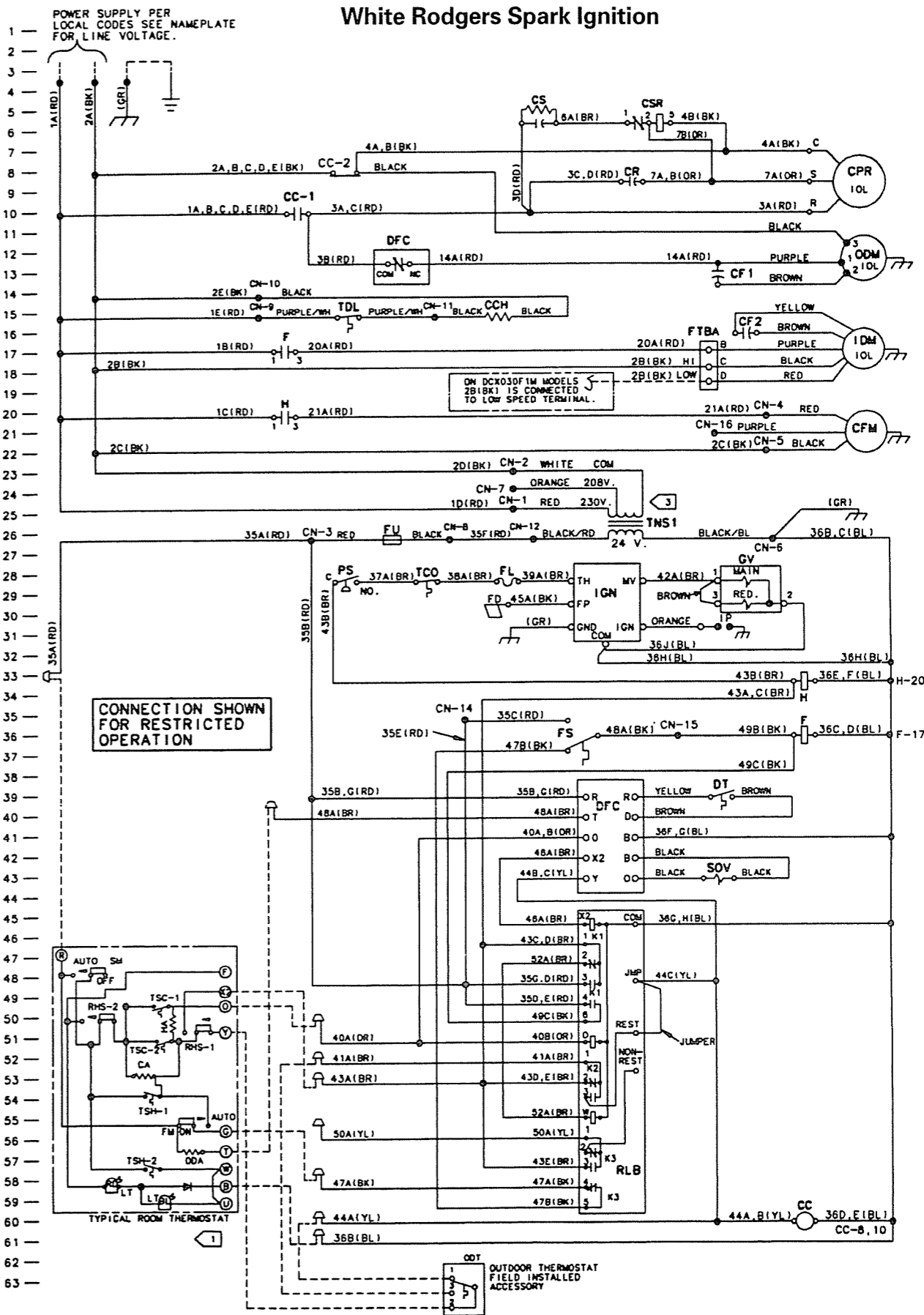

See Legend on Inside Front Cover

Hamilton Standard Direct Spark Furnace Controls

There are currently two versions of the Hamilton Standard Integrated Furnace controls:

1. CNT-1634 Single Stage Heat Control
2. CNT-1669 Two Stage Heat Control

The Hamilton Standard integrated controls have replaced the White Rodgers direct spark ignition controls that were used when the IMPACK units were first produced. The Hamilton Standard controls were introduced in August of 1993.

The Hamilton Standard integrated controls are solid state micro-processor based controls which can continually monitor analyze and control the proper operation and timings of the indoor motor, combustion fan motor, and ignition sequence.

The control also provides continuous surveillance of the thermostat, safety circuits and flame sense circuit during normal operation and will instantly shut off the gas flow if any faults are detected.

The Honeywell combination fan limit control used on previous models has been replaced with a separate thermally operated bi-metal disc type safety. The furnace control will energize the indoor blower heating speed 45 seconds after flame current is detected.

The heating fan on delay is fixed at 45 seconds on both the single and two stage controls. The heating fan delay off timing is also controlled by the furnace control and can be field adjusted for 60 or 90 seconds.

The furnace control also provides an optional cooling fan off delay of 0 or 80 seconds. The 80 second delay setting will allow the indoor motor to operate for 80 seconds after the compressor shuts off to increase system efficiency. The integrated furnace control must receive a "Y" (compressor) and "G" (fan) signal for the 80 second cooling fan off delay to operate. If the "Y" signal is not received, the control does not know the unit is operating in cooling and will not enable the fan delay off cycle.

The heating and cooling fan off delay timings are selected by setting the DIP switches on the integrated control.

All of the IMPACK gas electric package units have two speed indoor blower motors. The YCC models will operate on one of the two speeds for both heating and cooling. The YCX018-042 single stage heat models have an additional fan relay provided to allow a change in airflow during heating operation.

The control must receive a "Y" (compressor) signal in cooling to energize high speed.

The YCY and DCY 5 ton models have variable speed ECMTM2 indoor motors in order to maintain the 12.0 SEER rating across the entire product line. The variable speed ECMTM2 motors provide additional comfort control when the Comfort-R enhanced cooling mode is selected. The enhanced mode allows fast cooling of the evaporator coil on start up by reducing the airflow to 50% for the first minute of operation. The airflow is then automatically increased to 80% of selected cooling airflow for the next 7.5 minutes, providing increased moisture removal. After 8.5 minutes if the thermostat is still calling for cooling, the airflow will be increased to 100% of the selected cooling airflow providing maximum capacity in order to satisfy the load on the structure. When the thermostat is satisfied, the airflow will be reduced to 50% of the selected cooling airflow for 3 additional minutes before shutting off (see page 46).

ECMTM Quick Check – BRD0986

Blower Motor Will Not Run

1. Jumper 24 Volt A.C. "R" terminal to "G" terminal on the Low Voltage Terminal board.

Does motor run?

No: Go to step number 2.

Yes: Motor runs, check thermostat and thermostat wire.

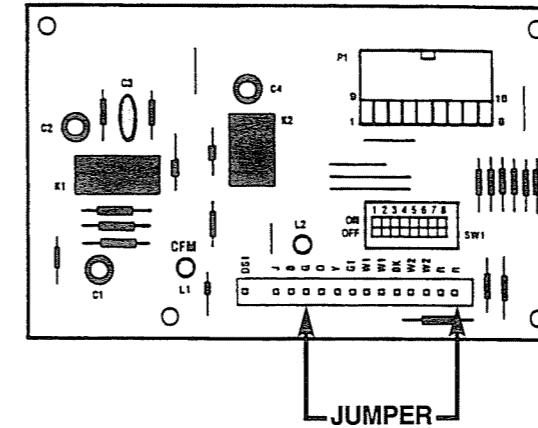

Package Unit Motor Control Board (ECMC)

2. Unplug 16 wire low voltage harness from the motor control board. Jumper 24 Volts A.C. to pins number 12, number 15 and common pins number 1 and number 3.

Does the motor run?

No: Go to step number 3.

Yes: Replace the motor control board..

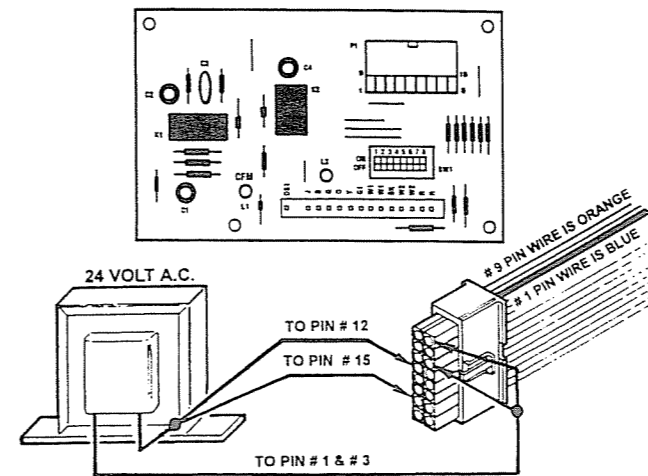

3. Unplug 16 wire low voltage harness from the motor. Jumper 24 Volts A.C. to motor low voltage plug pins number 12 and number 15 and pins number 1 and number 3 which are common.

Does motor run?

No: Go to step number 4.

Yes: Fault is in the 16 wire low voltage harness. Repair or replace it.

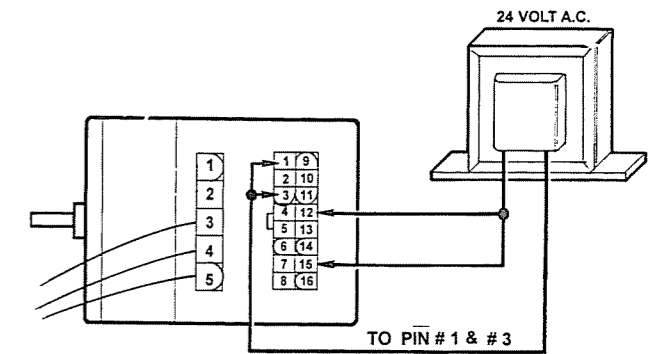

4. Is the line voltage to the motor high voltage power plug pin number 4 and pin number 5 correct?

Package unit ECMTM motor correct voltage is 220 volts A.C.

No: Correct line voltage fault.

Yes: Line voltage correct and motor will not run. Replace motor module.

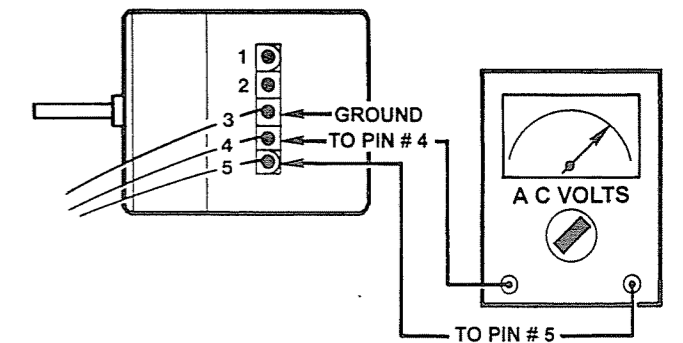

ECM™ Control Input

Air Flow Priority

The ECM™ motor will run at the called for CFM. If two or more calls are being received at the same time, G, Y and W1 for example, the W1 input will have priority over G and Y.

TERMINAL	PIN NO.	FUNCTION
BK	# 10	Humidistat input, if a humidistat is not installed, a jumper must be installed between "R" and "BK".
W1	# 2	CFM, blower speed, for low heat. W1 used for an on or off command for the motor. W1 airflow will be 85% of cooling "Y" airflow.
W2	# 13	CFM, blower speed for high heat. W2 airflow will be 100% of cooling airflow.
G	# 15	On or off command for the motor. Air flow will be 50% of cooling "Y" CFM programmed.
G1	# 6	Package unit air flow will be 100 % cooling "Y" CFM programmed. (Jumper "G" to "G1" for 100% CFM during continuous fan operation.)
Y	# 14	CFM, blower speed, for cooling.
CFM	# 16	LED, will flash the number of times programmed by the Dip switches in the cooling or heating cycle. Cooling CFM is programmed by Dip switches # 1 and # 2 tonnage times dip switch # 3 and # 4 CFM per ton.
B	# 1, 3, & 8	Common 24 VAC.
O	# 9	Cooling cycle humidistat enable. On a cooling system, "Y" must be jumpered to "O" for humidistat operation.
R	# 12	Power and timing reference for ECM™2 motor computer and power to the Dip switches.

Dip Switch Settings

SWITCH	PIN NO.	FUNCTION
#1 & #2	# 5	Tonnage of outdoor unit.
#3 & #4	# 7	CFM per ton. 350, 400 or 450 CFM.
#5 & #6	# 4 ①	Are used to set up indoor blower time delay at the end of a cooling cycle. If a delay or ramped on cycle is programmed, on DCY Dual Fuel units, the heating blower off cycle will also be affected during heat pump operation only. The cooling air flow, CFM, will be reduced by 50%. The ignition control will control the amount of time the blower is on at the end of the gas heating cycle.
#7 & #8	# 11	DIP Switches 7 and 8 are not used on package gas electrics. The position of switch 7 and 8 have no effect on airflow.

① "G" and "Y" lead must be removed from Ignition Control board (IGN), for ramped operation to work. Units with serial numbers beginning with J48 or later will have the "G" and "Y" lead removed from the ignition control.

Identifying Hamilton Standard Controls

Single Stage – CNT-1634

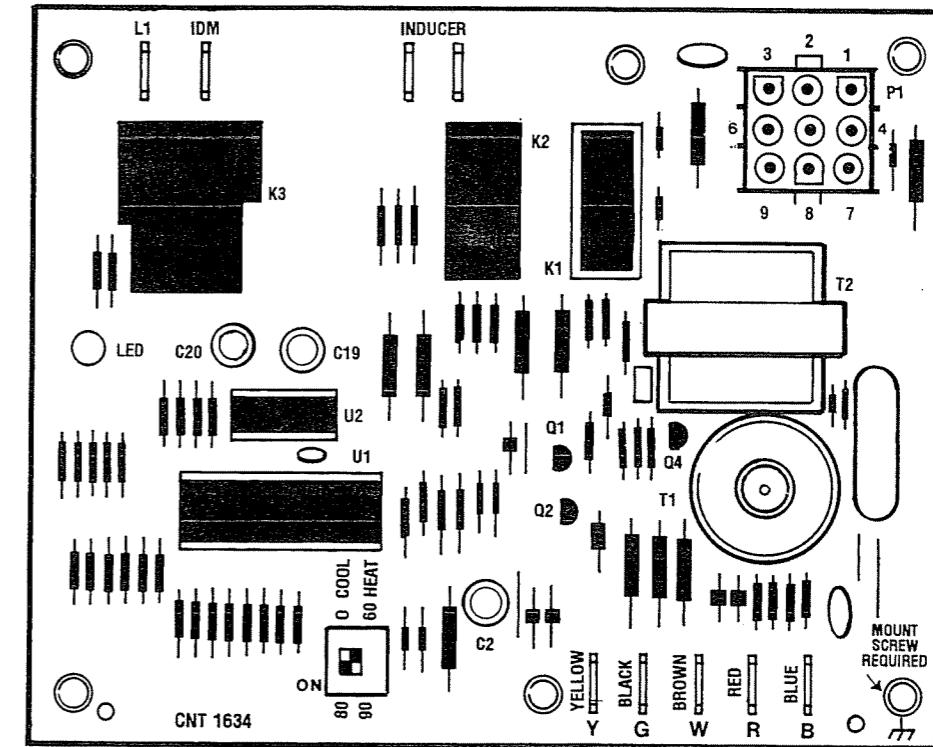

Two Stage CNT-1669

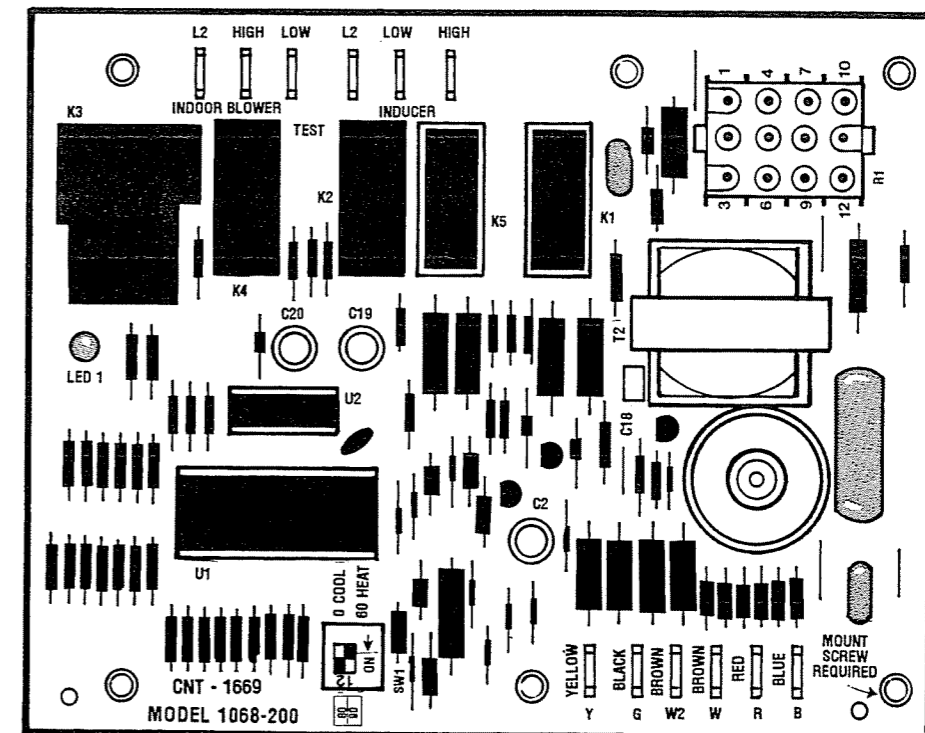

Hamilton Standard Integrated Control Timing

SINGLE STAGE – CNT-1634, TWO STAGE – CNT-1669

INDOOR BLOWER (IDM)

Heating Fan ON Delay	45 Sec. (After Flame is sensed)
2nd Stage Delay	30 Sec. (Delay On and Off)
Heating Fan OFF Delay	60 or 90 (Field Selectable)
Cooling Fan OFF Delay ②	0 or 80 Sec. (Field Selectable)
Continuous Fan ("G" Only) ①	High Speed Energized / Low Speed on 2 Stage Controls

COMBUSTION FAN MOTOR (CFM)

Pre-Purge	15 Sec.
Post-Purge	5 Sec.
Retry Inter-Purge ③	60 Sec. (Plus 15 Sec. Pre-Purge)

IGNITION CONTROL (IGN)

Minimum Flame Current5 Microamps DC
Normal Flame Current	4.5 Microamps DC
Trial for Ignition (Spark Time)	2 Sec. Min. 7 Sec. Max. (25,000 Volts)
Flame Failure Response8 Sec. (Loss of Flame)
Ignition retries (Before Lockout) ④⑤	2 Consecutive After Initial Try (3 Total)
Time Between Trials For Ignition	15 Sec. if Control has Sensed Flame 75 Sec. if Control has not Sensed Flame
Ignition Recycles (Before Lockout) ⑤⑥	16 (During the same call for Heat)
W1 and W2 Called Simultaneously	10 Min. Delay Before 2nd Stage

Notes

- ① Indoor Blower Motor will be de-energized if call for heat ("W") is received during continuous fan operation. Dual Fuel units only.
- ② Optional cooling Fan OFF Delay requires "Y" and "G" signal for proper operation.
- ③ Retry interpurge (75 sec. total) will only occur if ignition control has not sensed flame current during the 7 second trial for ignition period.
- ④ If flame current is sensed on or before the 3rd attempt, the retry counter is reset and 3 more attempts can be made.
- ⑤ Control will automatically reset in 2 hours if a call for heat exists.
- ⑥ When 16 total ignition recycles have occurred during the same call for heat, the control will lockout.

Package Gas Electric ECM™ Motor Operation

Ramped Operations

Dip Switch No. 5 and No. 6 ON, will work in the Cooling and Heat Pump Cycle Only. A "W" call disables the ramped operation feature. A call on "Y" and "G" together is all that is needed to get a ramped ON and OFF cycle. The Computer program is different from a furnace as it does not require the "O" input to enable a ramped cycle.

Cooling Humidistat Operation

"BK" terminal is jumpered to "R" terminal, at the (ECMC) Motor Control Board plug. This jumper must be cut on some models or removed on other models to install a cooling humidistat. Blower CFM will be reduced 20% when the humidistat is open, high humidity.

Air Flow Priority

W1 or W2, not the highest air flow of "Y" or "W" programmed.

First Stage Heat and Heat Exchanger Cool-Down Cycle

Airflow will be 85% of the cooling air flow. The heating cool-down time is controlled by the ignition module. (60 or 90 sec)

DIP Switch

DIP Switch #7 and #8 are not functional.

Cooling Cycle

Blower Time Delay to off is controlled by the ECM™ Motor and Dip Switch No. 5 and No. 6 on the (ECMC) Motor Control Board. The ignition module cooling time delay dip switch must be set to zero seconds, if ramped operation or a time-delay cycle is selected.

Fan Continuous Operation

The airflow is 50% of the cooling air flow. If cooling air flow is required for continuous fan operation, on units using a motor control board #BRD0986. Jumper G1 pin and G pin at the (ECMC) motor control board plug. A factory installed jumper pigtail, (BK), is connected to G1 pin for this purpose. On other variable speed models disconnect wire going to "Y" terminal on the motor control board, cap this wire off, and connect a jumper between "G" and "Y" terminal.

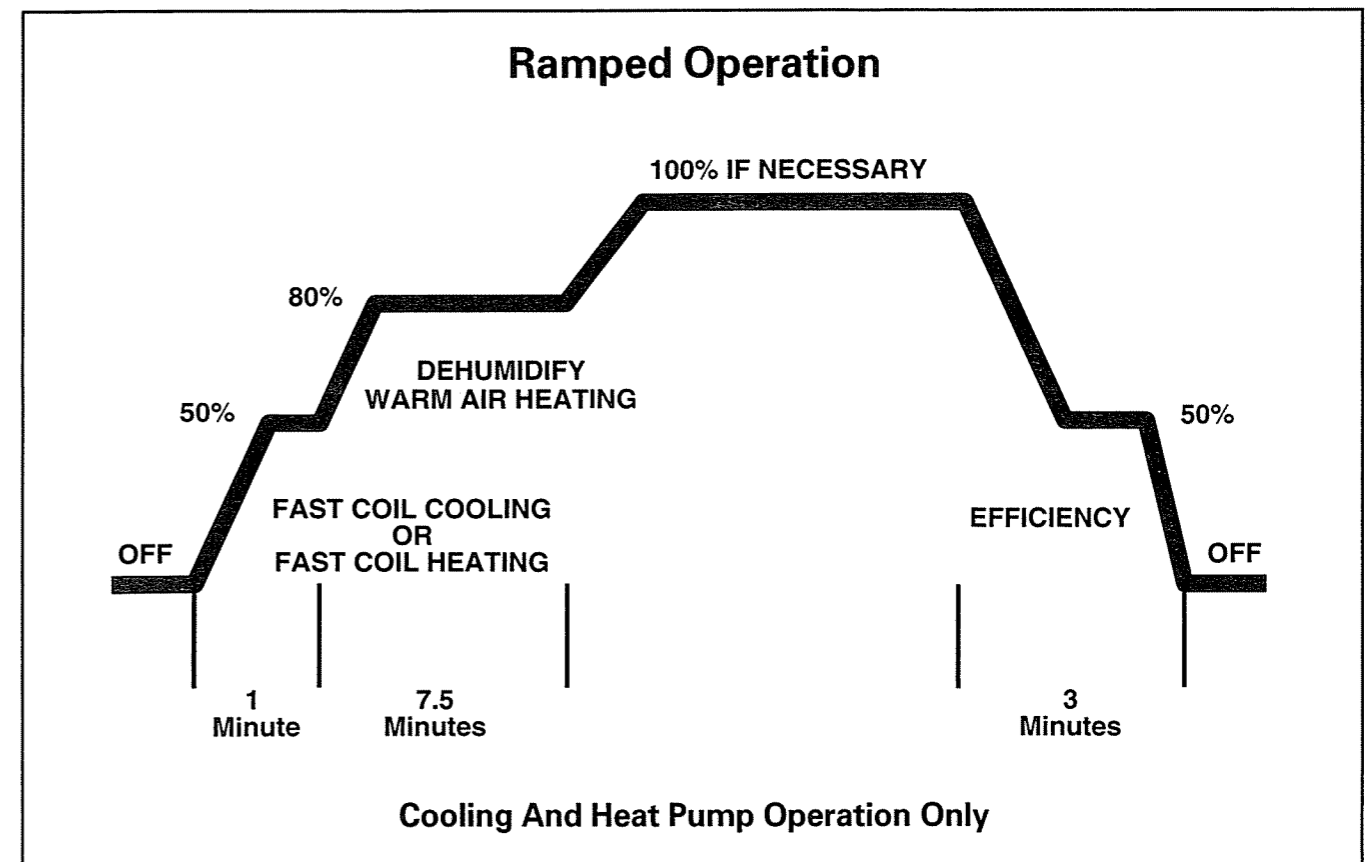

5 Ton YCY-F Two Stage Wiring Schematic with CNT 1866

Texas Instrument Spark Ignition – CNT-2219 Variable Speed ECM™ Indoor Motor

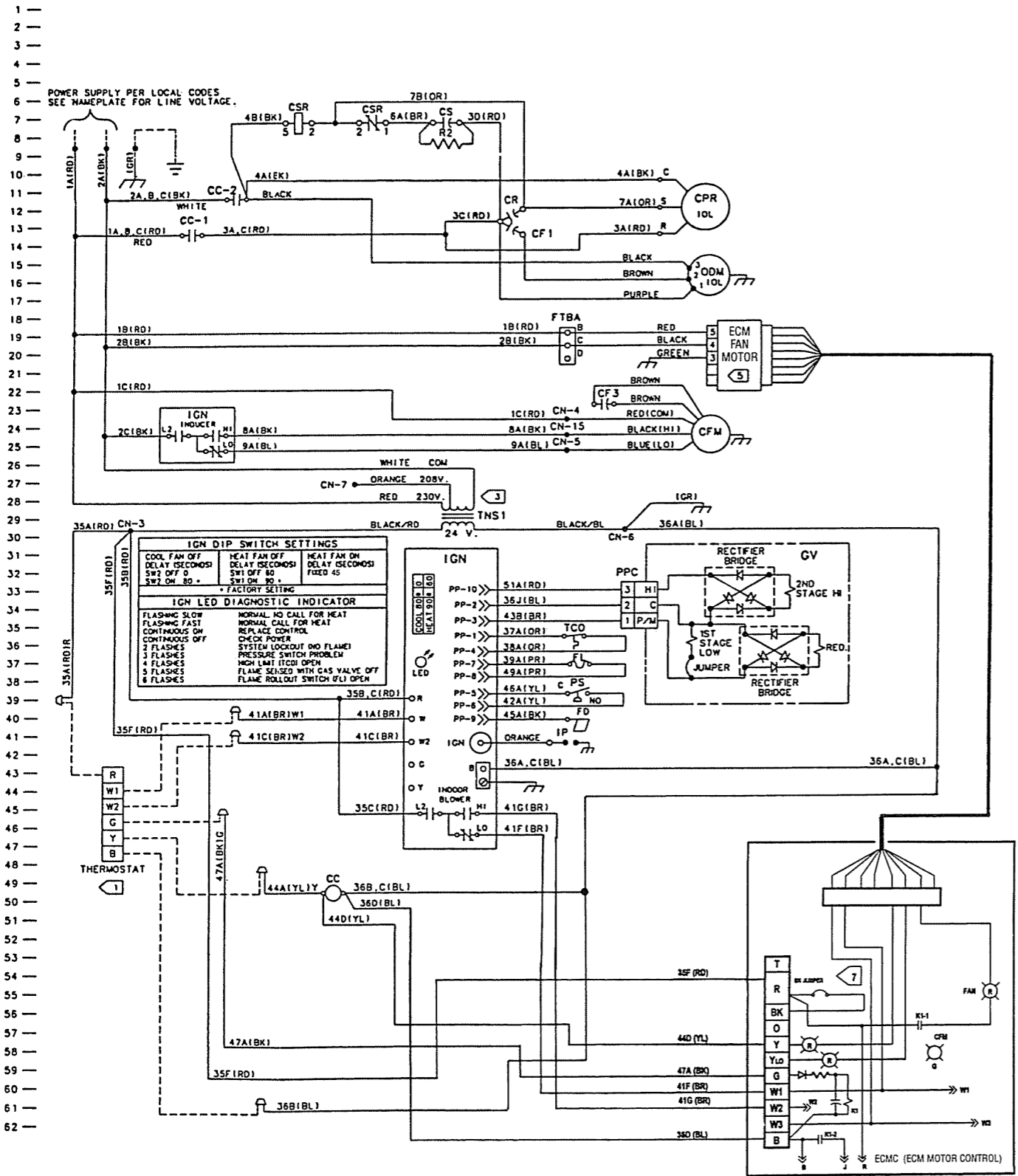

Hamilton Standard Self Diagnostic Features

The Hamilton Standard integrated furnace controls incorporate system fault analysis for quick shutoff of gas flow along with the ability to automatically restart the ignition system when the fault is no longer detected. The control micro-processor is continually monitored by a "Watchdog" circuit to prevent transient voltages (electrical interference) from causing no heat calls due to internal latch-up of the micro-processor.

Upon a call for heat, the furnace control will perform an "internal" and "external" check for faults before allowing an ignition sequence to begin.

The "internal" check confirms that the computer software and watchdog circuits are working properly. The "external" checks include all safety devices and pressure switches, making sure that they are in their proper normally open or normally closed position for the start of an ignition cycle. If the control detects a fault upon a call for heat, the red diagnostic LED will begin flashing at a rate according to the type fault detected (see IGN LED Diagnostic indicator table) until the fault is corrected.

IGN LED Diagnostic Indicator	
Flashing Slow	Normal No Call For Heat
Flashing Fast	Normal Call for Heat
Continuous On	Replace Control
Continuous Off	Check Power
Two Flashes	System Lockout (No Flame)
Three Flashes	Pressure Switch Problem
Four Flashes	High Limit (TCO) Open
Five Flashes	Flame Sensed with Gas Valve Off
Six Flashes	Flame Rollout Switch (FL) Open

Important: Diagnostic flash rate will be reset if power is interrupted to ignition control or primary power is turned off. Always check the flash rate before turning off power!

If a fault is detected during normal heating operation, the gas valve will be de-energized immediately and the red diagnostic LED will begin flashing at the rate for the type fault detected.

The single and two stage controls will automatically reset a lock-out fault due to loss of flame current every two hours as long as a continuous call for heat exists from the thermostat.

The integrated controls can be manually reset by interrupting the 24 volt signal to the ignition control for longer than three seconds.

The minimum flame current for the single and two stage controls is .5 micro-amps DC. The typical flame current signal during normal operation will vary from 3.0 to 5.0 micro-amps. DC.

Hamilton Standard Abnormal Heating Operation

Pressure Switch Operation

If during the start up of a normal heating cycle, the safety pressure switch is sensed closed prior to energizing the combustion fan motor, the control will begin flashing the red diagnostic LED 3 times indicating a pressure switch error. When the pressure switch contacts open, the normal ignition sequence will begin and the 3 flash fault will return to a steady fast flash indicating a normal call for heat.

Upon a call for heat, the two stage control will energize the combustion fan on high speed for 5 seconds, if the pressure switch contacts have closed, the combustion fan motor will be switched to low speed for the 15 second pre-purge. If the pressure switch contacts are not closed after 5 seconds, the combustion fan motor will remain running on high speed and the diagnostic LED will begin flashing 3 times while waiting for closure of the pressure switch contacts.

If the pressure switch contacts close and then open during the 15 second prepurge, or if the control does not sense flame on the first trial for ignition, the combustion fan motor will be switched to high speed. After the 60 second interpurge and the 15 second prepurge, the gas valve will be energized on second stage. If flame is sensed for 10 seconds after the second or third trial for ignition, the gas valve and combustion fan motor will be switched back to low and normal first stage heating operation will continue.

Should the pressure switch open during normal heating operation on either single or two stage controls, the gas valve will be de-energized immediately and the diagnostic LED will begin flashing three times indicating a pressure switch error. The combustion fan motor will continue to run (Two stage controls will switch the combustion fan to HI speed) and the indoor blower motor will begin the selected 60 or 90 second heating fan off delay.

High Temperature Limit (TCO)

The integrated control will de-energize the gas valve and energize the combustion and indoor fan motor whenever the limit switch is detected open during a call for heat. Two stage controls will energize the combustion fan and indoor motor on high speed if the limit switch opens during a second stage call for heat. The red diagnostic LED will begin flashing 4 times.

When the limit switch resets, the four flash diagnostic will be discontinued and the ignition sequence will begin. The indoor blower motor will continue to run during the ignition sequence and the normal heating fan on delay will not occur.

Flame Roll Out Operation

The integrated control will de-energize the gas valve and begin flashing the red diagnostic LED 6 times when the control senses an open flame roll out circuit. The indoor blower and combustion fan motors will be sequenced through their normal off delay timings and then stop. The flame roll out fuseable link is a single use device and normally must be replaced if it has opened. However, if the temperature the fuseable link senses is approaching the trip temperature but does not exceed it, the contacts may open and then reclose intermittently.

Single stage controls with date codes of 9418 or earlier will lock out whenever the control detects an open fuse link circuit.

The two stage controls will begin another ignition sequence upon the closure of an intermittent fuseable link.

The control power or thermostat call for heat must be interrupted for at least 3 seconds to reset the lock out condition.

System Lockout (Loss of Flame)

The integrated control will flash the diagnostic LED 2 times whenever a lock out condition occurs due to loss of flame or failure to detect flame. The inducer and indoor motor will complete their off delay timings and then stop. **The single and two stage controls will automatically reset a lock out condition every two hours** as long as a continuous call for heat exists. The lockout condition can manually reset by interrupting the 24 volt power to the ignition control for at least 3 seconds.

Flame Sensed With Gas Valve Off

Whenever the control detects a flame signal without a call for heat or when the gas valve is not energized, the indoor blower and combustion fan motor will be energized and the control will lock out. The red diagnostic LED will begin flashing 5 times until the presence of flame is no longer detected. Two stage models will energize the high speed combustion and indoor fan speed.

5 Ton YCY-F Two Stage Wiring Schematic with BRD0986

Texas Instrument Spark Ignition - CNT-2219 Variable Speed ECM™ Indoor Motor

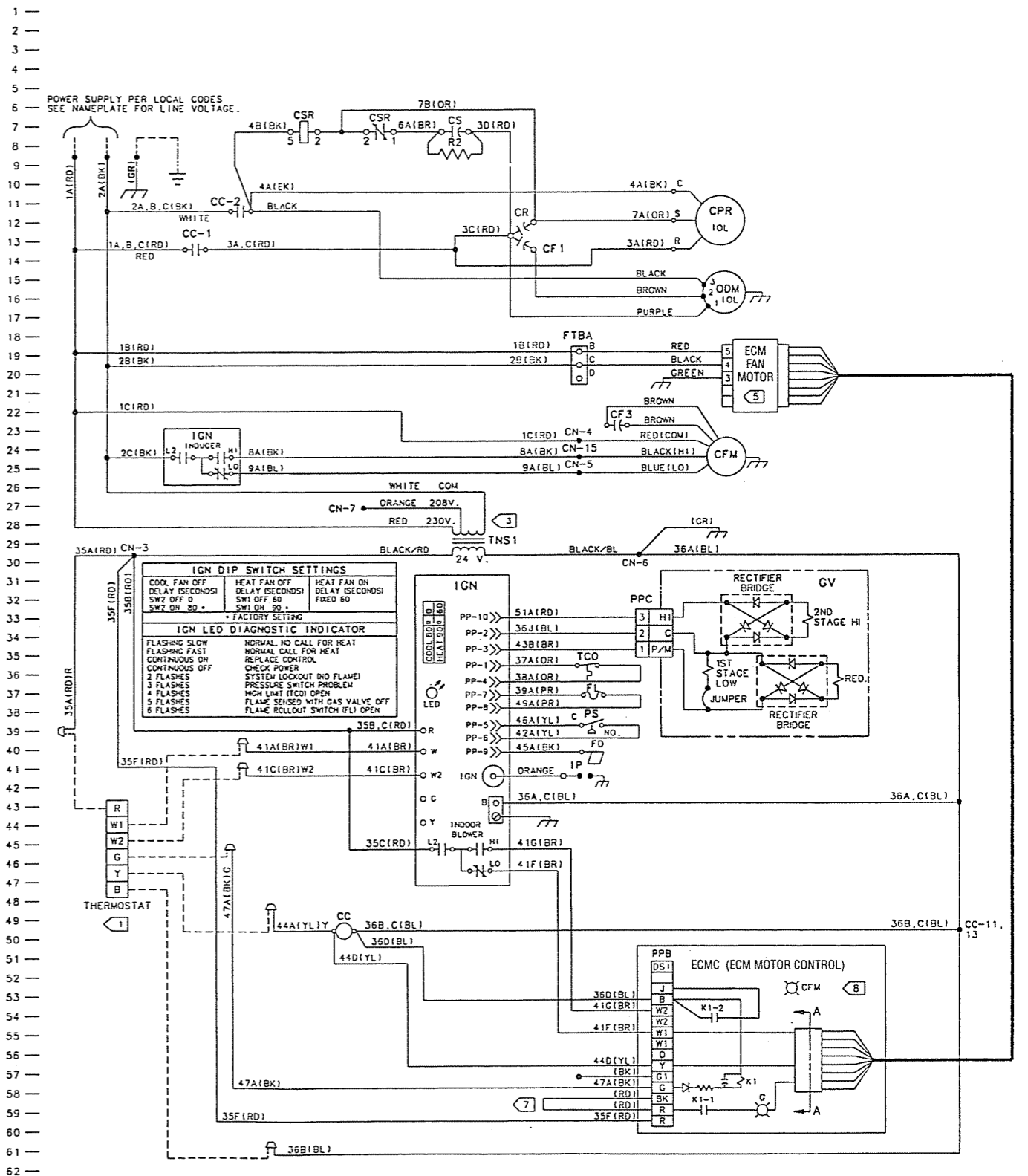

5 Ton YCY-F Two Stage Sequence of Operation

Texas Instrument Spark Ignition Variable Speed ECM™ Indoor Motor

When the service disconnect ② is in the "On" position, 230 volts is supplied from the line voltage input leads "L1" and "L2" ④ to the primary side of the low voltage control transformer (TNS1) ⑳⑳ and to terminals "4" and "5" of the ECM™ fan motor ⑲⑳. 24 volt power is supplied from the transformer secondary ㉑ to the ignition control (IGN) "R" and "B" terminals ㉓④③. Power is also supplied to the "R" and "B" terminals ④③④ of the indoor thermostat and to the "R" and "B" terminals of the ECMC motor control ⑥⑤④. The red diagnostic L.E.D. ③⑦ on the ignition control will begin flashing once per second (slow fast) indicating that the control is receiving 24 volts and awaiting a call for heat.

On a first stage call for heat, 24 volt power will be supplied from the indoor thermostat "W1" terminal ④④ to the "W" terminal ④① of the ignition control (IGN). The ignition control will perform a self check routine and then check the limit switch (TCO) for normally closed contacts ③⑤, the flame rollout fuseable link (FL) for continuity ③⑦, and the pressure switch (PS) for normally open contacts ③⑨.

With all safeties and switches in their proper position, the ignition control will open the normally closed inducer "LO" contacts and then close the normally open "L2" and "HI" inducer contacts ㉒ energizing the combustion fan motor (CFM) ㉒ on high speed for 5 seconds. As the combustion fan motor (CFM) comes up to speed, the control will verify that the pressure switch (PS) contacts ③⑨ have closed and switch the combustion fan motor to low speed for a 15 second prepurge by opening the "HI" speed inducer relay contacts ㉒ and closing the "LO" speed inducer relay contacts ㉒.

The control will then simultaneously energize the spark ignitor probe (IP) ④① and supply 24 volts to terminals "1" and "2" on the gas valve ③⑤③④, energizing the first stage (low fire) of the gas valve ③⑤.

The ignitor probe (IP) ④① will spark for a minimum of 2 seconds and a maximum of 7 seconds. Once the flame detector (FD) ④① senses a flame current signal of .5 microamps D.C. or greater, the ignitor (IP) will stop sparking and the 45 second heating fan on delay timer will begin. The ECM™ fan motor ㉒ will be energized after 45 seconds when the ignition control (IGN) closes the normally open "L2" blower relay contacts ④⑤, supplying 24 volts through the normally closed "LO" indoor blower contacts ④⑥, supplying 24 volts to the "W1" terminal of the ECMC motor control ⑥⑤ energizing the ECM™ fan low heat speed.

With first stage operating, a second stage call for heat will supply power from the "W2" terminal of the thermostat ④⑤ to the "W2" terminal of the ignition control ④①. The combustion fan motor will switch to high speed as the "LO" speed inducer contacts open ㉒ and the normally open "HI" speed inducer relay contacts close ㉒. The second stage gas valve ③③ will also be energized by supplying 24 volts to terminal "3" (HI) on the gas valve through "W2" on the ECMC board. The ECM™ fan ㉒ will be switched to "HI" after 30 seconds. The ignition controls normally open "LO" speed indoor blower relay contacts will open ④⑥. The ignition control has sent a signal supplying 24 volts to the "W2" terminal on the ECMC motor control ⑥⑤, the motor programming will energize the ECM™ fan on high heat speed.

When second stage is satisfied, the combustion fan motor (CFM) will be switched back to "low" speed and the 2nd stage gas valve ③③ will be de-energized. The ECM™ fan motor will be switched back to low speed after 30 seconds. The unit will continue to operate in 1st stage operation as long as there is a call for heat.

Once first stage is satisfied, the 24 volt signal will be removed from the "W" terminal of the ignition control ④①. The first stage gas valve will close, instantly stopping gas flow to the burners. The flame detector will sense the loss of flame current and begin the 5 second combustion fan motor post purge, and the 60 or 90 second heating fan off delay timer. The "L2" inducer relay contacts will open ㉒ after the 5 second post purge de-energizing the combustion fan motor. The "L2" blower relay contacts ㉒ will open, de-energizing the ECM™ fan motor after the 60 or 90 second heating fan off delay period.

Texas Instrument Direct Spark Furnace Controls

There are currently three versions of the Texas Instrument Integrated Furnace controls used in the "F" models of Impack units:

1. CNT-2216 Single Stage Heat Control
 2. CNT-2217 Two Stage Heat Control
 3. CNT-2219 ECM™
- } Replaced by Kit 06839 which uses a CNT03457
} Replaced by Kit 06840 which uses a CNT03458

The Texas Instrument integrated controls have replaced the Hamilton Standard direct spark ignition controls that were used since August of 1993 on the IMPACK line of products.

The Texas Instrument integrated controls are solid state micro-processor based controls which can continually monitor analyze and control the proper operation and timings of the indoor motor, combustion fan motor, and ignition sequence.

The control also provides continuous surveillance of the thermostat, safety circuits and flame sense circuit during normal operation and will instantly shut off the gas flow if any faults are detected.

The Honeywell combination fan limit control is a thermally operated bi-metal disc type safety. The furnace control will energize the indoor blower heating speed 45 seconds after flame current is detected.

The heating fan on delay is fixed at 45 seconds on both the single and two stage controls. The heating fan delay off timing is also controlled by the furnace control and can be field adjusted for 60 or 90 seconds.

The furnace control also provides an optional cooling fan off delay of 0 or 80 seconds. The 80 second delay setting will allow the indoor motor to operate for 80 seconds after the compressor shuts off to increase system efficiency. The integrated furnace control must receive a "Y" (compressor) and "G" (fan) signal for the 80 second cooling fan off delay to operate. If the "Y" signal is not received, the control does not know the unit is operating in cooling and will not enable the fan delay off cycle.

The heating and cooling fan off delay timings are selected by setting the DIP switches on the integrated control.

All of the IMPACK gas electric package units have two speed indoor blower motors. The YCC models will operate on one of the two speeds for both heating and cooling. The YCX018-042 single stage heat models have an additional fan relay provided to allow a change in airflow during heating operation.

The control must receive a "Y" (compressor) signal in cooling to energize high speed.

The YCY and DCY 5 ton models have variable speed ECM™ indoor motors in order to maintain the 12.0 SEER rating across the entire product line. The variable speed ECM™ motors provide additional comfort control when the Comfort-R enhanced cooling mode is selected. The enhanced mode allows fast cooling of the evaporator coil on start up by reducing the airflow to 50% for the first minute of operation. The airflow is then automatically increased to 80% of selected cooling airflow for the next 7.5 minutes, providing increased moisture removal. After 8.5 minutes if the thermostat is still calling for cooling, the airflow will be increased to 100% of the selected cooling airflow providing maximum capacity in order to satisfy the load on the structure. When the thermostat is satisfied, the airflow will be reduced to 50% of the selected cooling airflow for 3 additional minutes before shutting off (see page 46).

Identifying Texas Instrument Controls

Single Stage - CNT-2216

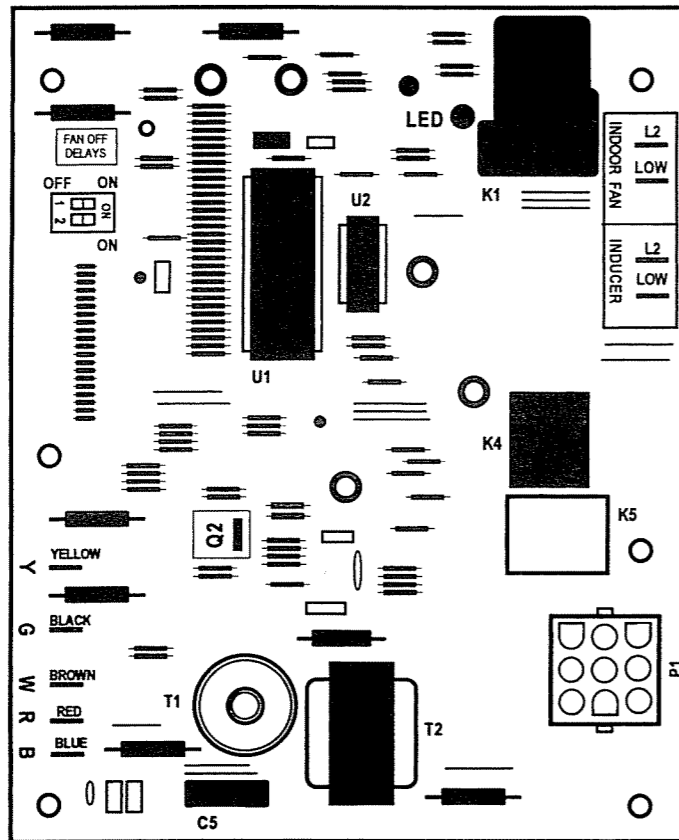

Two Stage CNT-2217

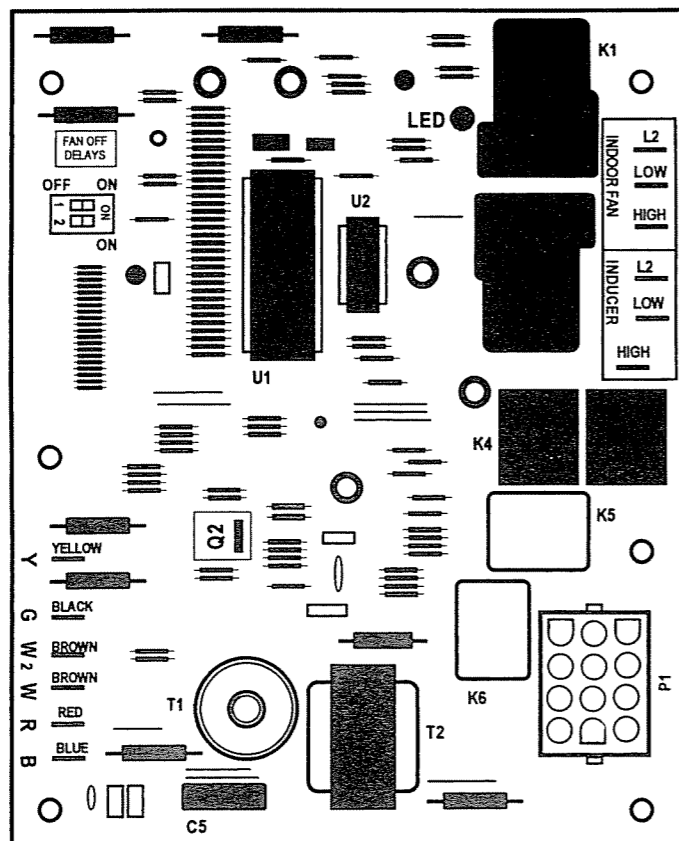

ECM™ Control Boards

CNT 1866

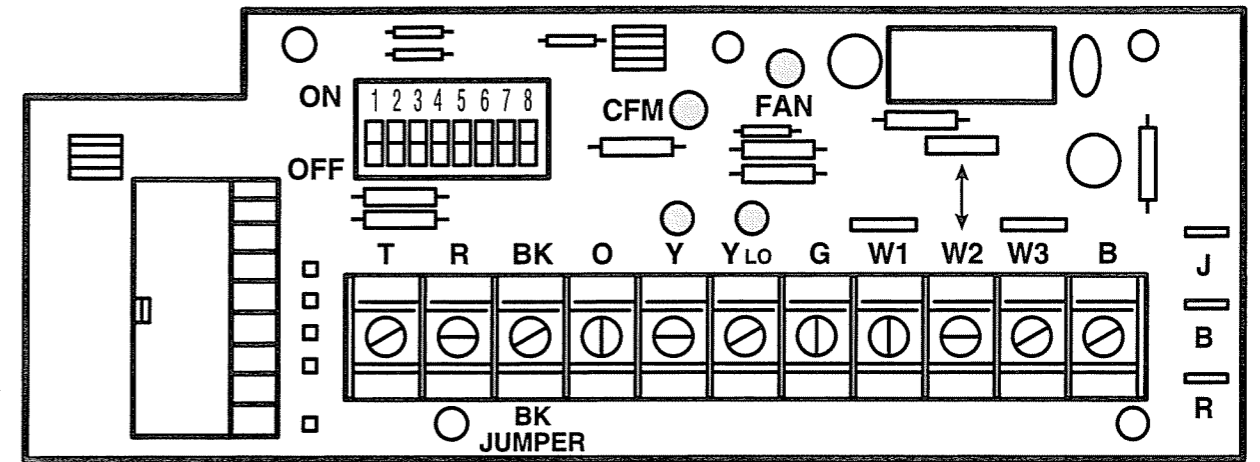

CNT03600

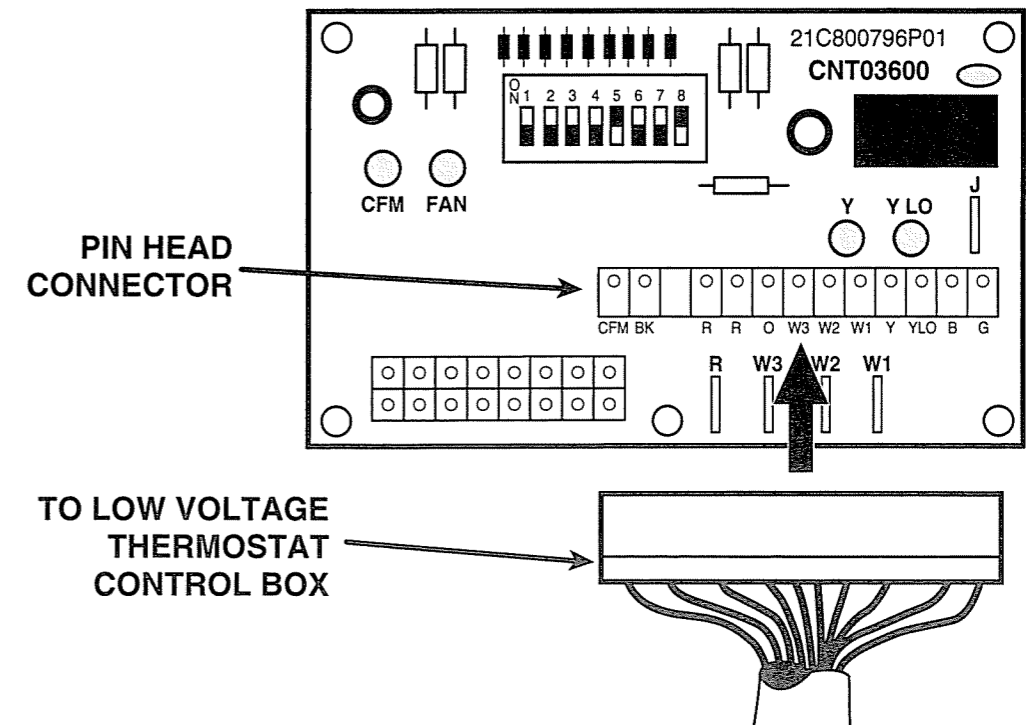

ECM™ Motor Control Boards

ECM™ Control

The Integrated Control Motor Control (ECMC) board, located in the indoor section, is powered by 24V AC system low voltage power. The Control is activated when 24V is applied between "R" and "B" terminals and provides the necessary interface and control function between the ECM™ indoor blower motor and associated system components or controls. The ECM™ motor is a micro-processor controlled, field programmable motor with field programming done on the Control board using eight dip switches.

The microprocessor in the motor has eleven inputs and one output. The eight dip switches work in pairs to provide four of the microprocessor inputs used to program cooling airflow, heating airflow and a time delay or ramp cycle.

The four dip-switched input commands sent to the motor microprocessor are modified 24V AC signals: half-wave positive rectified; half-wave negative rectified; full-wave rectified; and no signal. The other seven inputs are 24V AC signals used to turn the motor on or off and a command to run at programmed CFM for heating or cooling. 24V AC power is supplied to the motor as a timing reference and to power the microprocessor.

The one output from the microprocessor is used to turn the green CFM LED on and off on the Control board. By counting the number of flashes (one flash per hundred CFM), the CFM program can be checked. All boards pictured have similar functions. Note the changed order of letters in the connections.

ECM™ Control Boards

BRD0986

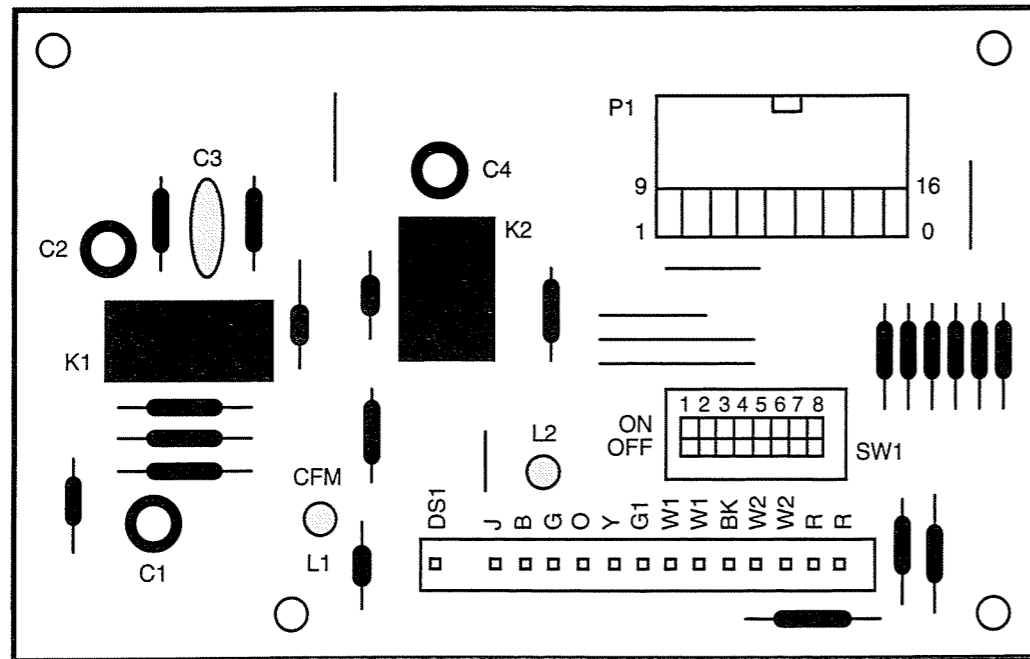

Identifying Texas Instrument Controls

ECM™ - CNT-2219

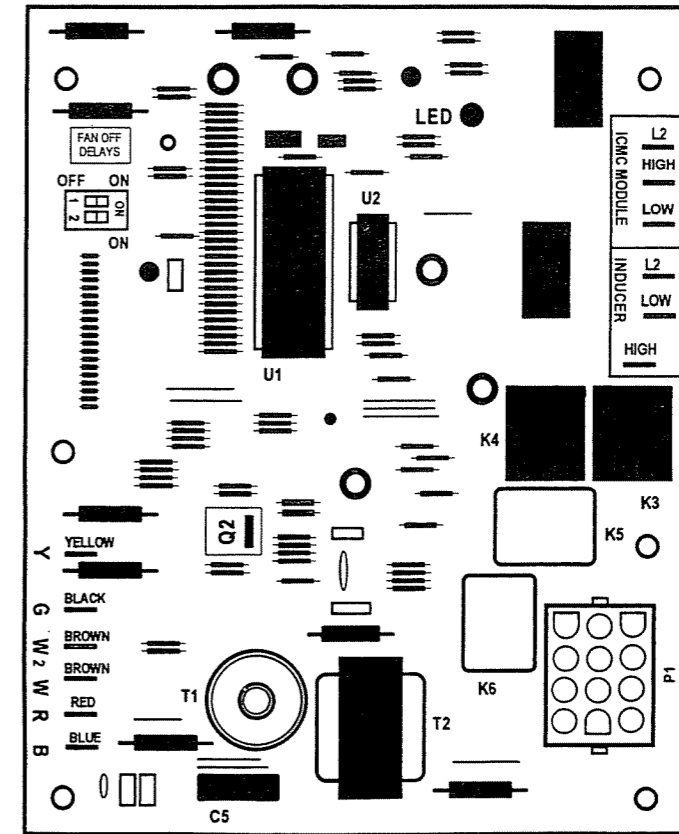

Texas Instrument Integrated Control Timing

SINGLE STAGE – CNT-2216, TWO STAGE – CNT-2217, ECM™ – CNT-2219

INDOOR BLOWER (IDM)

- Heating Fan ON Delay45 Sec. (After Flame is sensed)
- 2nd Stage Delay30 Sec. (Delay On and Off)
- Heating Fan OFF Delay60 or 90 (Field Selectable)
- Cooling Fan OFF Delay ②0 or 80 Sec. (Field Selectable)
- Continuous Fan (“G” Only) ①High Speed Energized / Low Speed on 2 Stage Controls

COMBUSTION FAN MOTOR (CFM)

- Pre-Purge15 Sec.
- Post-Purge5 Sec.
- Retry Inter-Purge ③60 Sec. (Plus 15 Sec. Pre-Purge)

IGNITION CONTROL (IGN)

- Minimum Flame Current5 Microamps DC
- Normal Flame Current4.5 Microamps DC
- Trial for Ignition (Spark Time)2 Sec. Min. 7 Sec. Max. (25,000 Volts)
- Flame Failure Response8 Sec. (Loss of Flame)
- Ignition retries (Before Lockout) ④⑤2 Consecutive After Initial Try (3 Total)
- Time Between Trials For Ignition15 Sec. if Control has Sensed Flame
60 Sec. if Control has not Sensed Flame
- Ignition Recycles (Before Lockout) ⑤⑥16 (During the same call for Heat)
- W1 and W2 Called Simultaneously10 Min. Delay Before 2nd Stage

Notes

- ① Indoor Blower Motor will be de-energized if call for heat (“W”) is received during continuous fan operation.
- ② Optional cooling Fan OFF Delay requires “Y” and “G” signal for proper operation.
- ③ Retry interpurge (75 sec. total) will only occur if ignition control has not sensed flame current during the 7 second trial for ignition period.
- ④ If flame current is sensed on or before the 3rd attempt, the retry counter is reset and 3 more attempts can be made.
- ⑤ Control will automatically reset in 2 hours if a call for heat exists.
- ⑥ When 16 total ignition recycles have occurred during the same call for heat, the control will lockout.

YCY-F Two Stage Wiring Schematic

Texas Instrument Spark Ignition

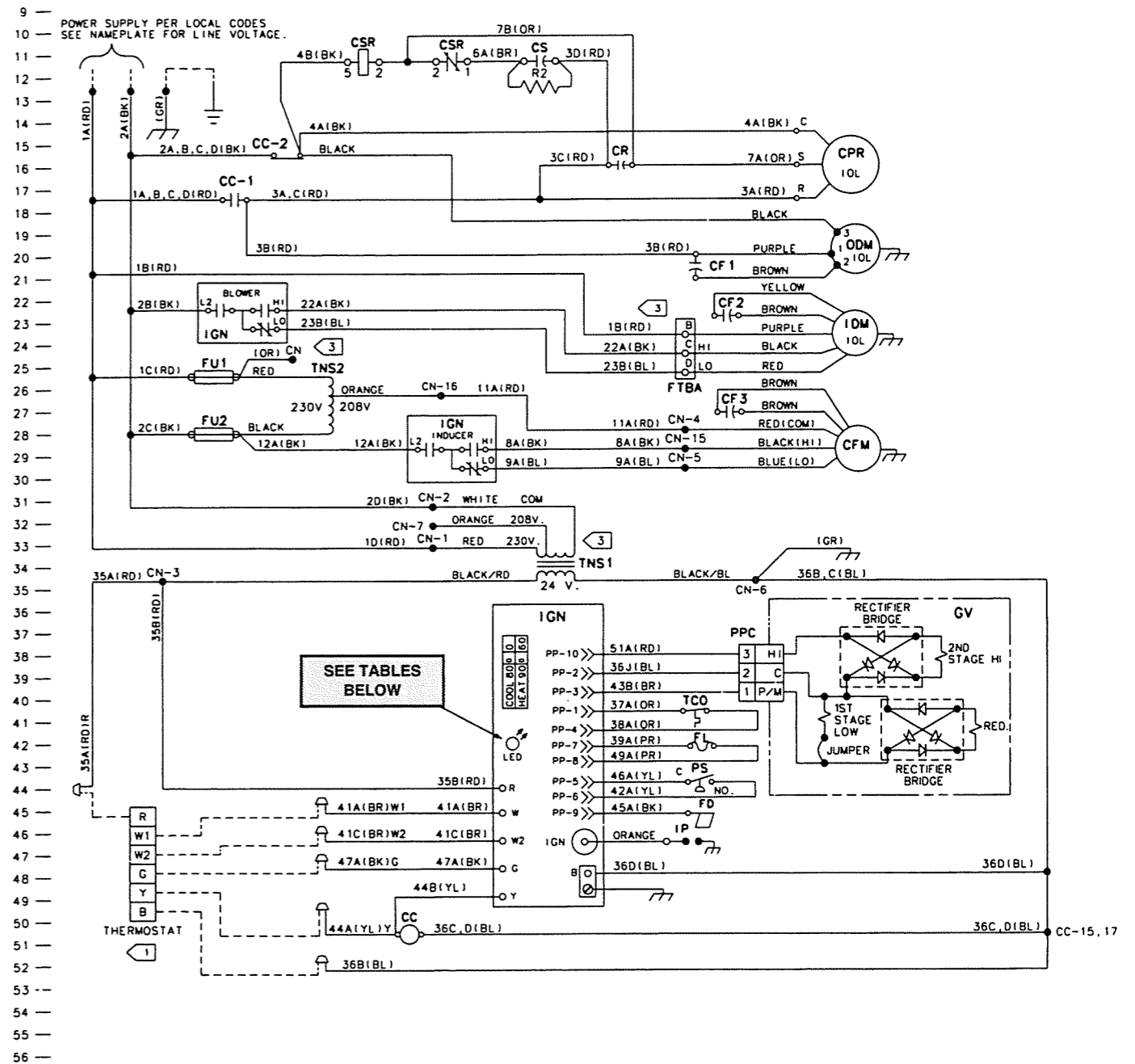

IGNITION TABLES				
DIP SWITCH SETTINGS			LED DIAGNOSTIC INDICATOR	
Cool Fan OFF	Heat Fan OFF	Heat Fan ON	Flashing Slow	Normal No Call For Heat
Delay (Seconds)	Delay (Seconds)	Delay (Seconds)	Flashing Fast	Normal Call For Heat
SW2 OFF 0	SW1 OFF 60	Fixed 45	Continuous ON	Replace Control
SW2 ON 80*	SW1 ON 90*		Continuous OFF	Check Power
			2 Flashes	System Lockout (No Flame)
			3 Flashes	Pressure Switch Problem
			4 Flashes	High Limit (TCO) Open
			5 Flashes	Flame Sensed With Gas Valve Off
			6 Flashes	Flame Rollout Switch (FL) Open
			7 Flashes	W1 and W2 Reversed

See Legend on Inside Front Cover

YCY-F Two Stage Sequence of Operation

Texas Instrument Spark Ignition

When the service disconnect ⑫ is in the "on" position, 230 volts is supplied from the line voltage input leads "L1" and "L2" ⑬ to the primary side of the low voltage control transformer (TNS1) ⑳㉑. 24 volt power is supplied from the transformer secondary ㉒ to the ignition control (IGN) "R" and "B" terminals ㉔㉕. Power is also supplied to the "R" and "B" terminals ㉖㉗ of the indoor thermostat. The red diagnostic L.E.D. ㉘ on the ignition control will begin flashing once per second (slow fast) indicating that the control is receiving 24 volts and awaiting a call for heat.

On a first stage call for heat, 24 volt power will be supplied from the indoor thermostat "W1" terminal ㉙ to the "W" terminal ㉚ of the ignition control (IGN). The ignition control will perform a self check routine and then check the limit switch (TCO) for normally closed contacts ㉛, the flame rollout fuseable link (FL) for continuity ㉜, and the pressure switch (PS) for normally open contacts ㉝.

With all safeties and switches in their proper position, the control will open the normally closed inducer "LO" contacts ㉞ and then close the normally open "L2" and "HI" inducer contacts ㉟ energizing the combustion fan motor (CFM) ㊱ on high speed for 5 seconds. As the combustion fan motor (CFM) comes up to speed, the control will verify that the pressure switch (PS) contacts ㉛ have closed and switch the combustion fan motor to low speed for a 15 second prepurge by opening the "HI" speed inducer relay contacts ㉟ and closing the "LO" speed inducer relay contacts ㉞.

The control will then simultaneously energize the spark ignitor probe (IP) ㊲ and supply 24 volts to terminals "1" and "2" on the gas valve ㉡㉢, energizing the first stage (low fire) of the gas valve ㉣.

The ignitor probe (IP) will spark for a minimum of 2 seconds and a maximum of 7 seconds. Once the flame detector (FD) ㉤ senses a flame current signal of .5 microamps D.C. or greater, the ignitor (IP) will stop sparking and the 45 second heating fan on delay timer will begin. The indoor blower motor (IDM) ㉦ will be energized after 45 seconds when the control closes the normally open "L2" blower relay contacts ㉧, supplying 230 volts through the normally closed "LO" blower contacts ㉨ to the "LO" speed winding of the indoor blower motor ㉦.

With first stage operating, a second stage call for heat will supply power from the "W2" terminal of the thermostat ㊳ to the "W2" terminal of the ignition control ㉚. The combustion fan motor will switch to high speed as the "LO" speed inducer contacts open ㉞ and the normally open "HI" speed inducer relay contacts close ㉟. The second stage gas valve ㉡ will also be energized by supplying 24 volts to terminal ㉣ "HI" on the gas valve. The indoor blower motor ㉦ will be switched to "HI" speed after 30 seconds. The normally open "HI" speed blower relay contacts ㉧ will close and the "LO" speed blower contacts will open ㉨.

When second stage is satisfied, the combustion fan motor (CFM) will be switched back to "Low" speed and 2nd stage gas valve ㉡ will be de-energized. The indoor blower motor will be switched back to low speed after 30 seconds. The unit will continue to operate in 1st stage operation as long as there is a call for heat.

Once first stage is satisfied, the 24 volt signal will be removed from the "W" terminal of the ignition control ㉚. The first stage gas valve will close, instantly stopping gas flow to the burners. The flame detector will sense the loss of flame current and begin the 5 second combustion fan motor post purge, and start the 60 or 90 second heating fan off delay timer. The "L2" inducer relay contacts will open ㉞ after the 5 second post purge period, de-energizing the "LO" speed combustion fan motor. The "L2" blower relay contacts ㉧ will open, de-energizing the low speed indoor blower after the 60 or 90 second heating fan off delay period.

Texas Instrument Self Diagnostic Features

The Texas Instrument integrated furnace controls incorporate system fault analysis for quick shutoff of gas flow along with the ability to automatically restart the ignition system when the fault is no longer detected. The control micro-processor is continually monitored by a "Watchdog" circuit to prevent transient voltages (electrical interference) from causing no heat calls due to internal latch-up of the micro-processor.

Upon a call for heat, the furnace control will perform an "internal" and "external" check for faults before allowing an ignition sequence to begin.

The "internal" check confirms that the computer software and watchdog circuits are working properly. The "external" checks include all safety devices and pressure switches, making sure that they are in their proper normally open or normally closed position for the start of an ignition cycle. If the control detects a fault upon a call for heat, the red diagnostic LED will begin flashing at a rate according to the type fault detected (see IGN LED Diagnostic indicator table) until the fault is corrected.

IGN LED Diagnostic Indicator	
Flashing Slow	Normal No Call For Heat
Flashing Fast	Normal Call for Heat
Continuous On	Replace Control
Continuous Off	Check Power
Two Flashes	System Lockout (No Flame)
Three Flashes	Pressure Switch Problem
Four Flashes	High Limit (TCO) Open
Five Flashes	Flame Sensed with Gas Valve Off
Six Flashes	Flame Rollout Switch (FL) Open

Important: Diagnostic flash rate will be reset if power is interrupted to ignition control or primary power is turned off. Always check the flash rate before turning off power!

If a fault is detected during normal heating operation, the gas valve will be de-energized immediately and the red diagnostic LED will begin flashing at the rate for the type fault detected.

The single and two stage controls will automatically reset a lock-out fault due to loss of flame current every two hours as long as a continuous call for heat exists from the thermostat.

The integrated controls can be manually reset by interrupting the 24 volt signal to the ignition control for longer than three seconds.

The minimum flame current for the single and two stage controls is .5 micro-amps DC. The typical flame current signal during normal operation will vary from 3.0 to 5.0 micro-amps. DC.

Texas Instrument Abnormal Heating Operation

Pressure Switch Operation

If during the start up of a normal heating cycle, the safety pressure switch is sensed closed prior to energizing the combustion fan motor, the control will begin flashing the red diagnostic LED 3 times indicating a pressure switch error. When the pressure switch contacts open, the normal ignition sequence will begin and the 3 flash fault will return to a steady fast flash indicating a normal call for heat.

Upon a call for heat, the two stage control will energize the combustion fan on high speed for 5 seconds, if the pressure switch contacts have closed, the combustion fan motor will be switched to low speed for the 15 second pre-purge. If the pressure switch contacts are not closed after 5 seconds, the combustion fan motor will remain running on high speed and the diagnostic LED will begin flashing 3 times while waiting for closure of the pressure switch contacts.

If the pressure switch contacts close and then open during the 15 second prepurge, or if the control does not sense flame on the first trial for ignition, the combustion fan motor will be switched to high speed. After the 60 second interpurge and the 15 second prepurge, the gas valve will be energized on second stage. If flame is sensed for 10 seconds after the second or third trial for ignition, the gas valve and combustion fan motor will be switched back to low and normal first stage heating operation will continue.

Should the pressure switch open during normal heating operation on either single or two stage controls, the gas valve will be de-energized immediately and the diagnostic LED will begin flashing three times indicating a pressure switch error. The combustion fan motor will continue to run (Two stage controls will switch the combustion fan to HI speed) and the indoor blower motor will begin the selected 60 or 90 second heating fan off delay.

High Temperature Limit (TCO)

The integrated control will de-energize the gas valve and energize the combustion and indoor fan motor whenever the limit switch is detected open during a call for heat. Two stage controls will energize the combustion fan and indoor motor on high speed if the limit switch opens during a second stage call for heat. The red diagnostic LED will begin flashing 4 times.

When the limit switch resets, the four flash diagnostic will be discontinued and the ignition sequence will begin. The indoor blower motor will continue to run during the ignition sequence and the normal heating fan on delay will not occur.

Flame Roll Out Operation

The integrated control will de-energize the gas valve and begin flashing the red diagnostic LED 6 times when the control senses an open flame roll out circuit. The indoor blower and combustion fan motors will be sequenced through their normal off delay timings and then stop. The flame roll out fuseable link is a single use device and normally must be replaced if it has opened. However, if the temperature the fuseable link senses is approaching the trip temperature but does not exceed it, the contacts may open and then reclose intermittently.

Single stage controls with date codes of 9418 or earlier will lock out whenever the control detects an open fuse link circuit.

The two stage controls will begin another ignition sequence upon the closure of an intermittent fuseable link.

The control power or thermostat call for heat must be interrupted for at least 3 seconds to reset the lock out condition.

System Lockout (Loss of Flame)

The integrated control will flash the diagnostic LED 2 times whenever a lock out condition occurs due to loss of flame or failure to detect flame. The inducer and indoor motor will complete their off delay timings and then stop. **The single and two stage controls will automatically reset a lock out condition every two hours** as long as a continuous call for heat exists. The lockout condition can manually reset by interrupting the 24 volt power to the ignition control for at least 3 seconds.

Flame Sensed With Gas Valve Off

Whenever the control detects a flame signal without a call for heat or when the gas valve is not energized, the indoor blower and combustion fan motor will be energized and the control will lock out. The red diagnostic LED will begin flashing 5 times until the presence of flame is no longer detected. Two stage models will energize the high speed combustion and indoor fan speed.

DCX-F/DCY-F Restricted Mode Wiring Schematic

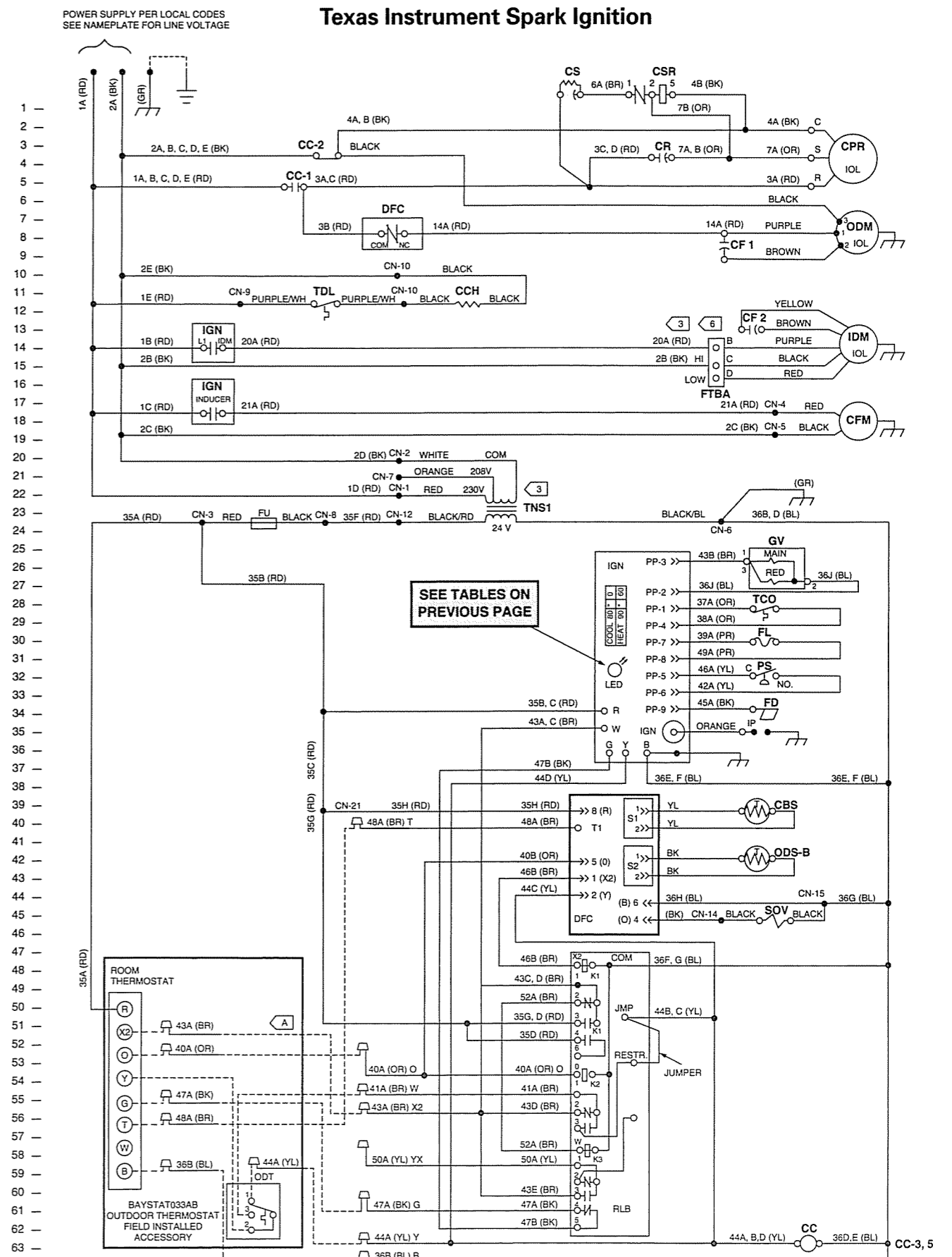

See Legend on Inside Front Cover

DCX-F/DCY-F Dual Fuel Restricted Operation

Texas Instrument Spark Ignition

NOTE: Units are shipped from factory in non-restricted mode. For restricted mode the jumper on the relay board (RLB) must be moved from the non-restricted pin to the restricted pin.

Restricted Mode (Requires outdoor thermostat)

During restricted mode of operation, the heat pump and gas furnace is controlled by the first stage of the indoor thermostat. **The second stage of the indoor thermostat (W) is not connected during the restricted mode of operation.** The first stage heat call (Y) is circuited through an outdoor thermostat (BAYSTAT033A) that will operate the heat pump when above the outdoor thermostat setting and operate the gas heat when below the outdoor thermostat setting.

Restricted-Sequence of Operation

Upon a first stage call for heat, 24 volts will be supplied from the "Y" terminal on the indoor thermostat ③ to the common terminal (terminal 2) of the outdoor thermostat (ODT) ②. If the outdoor ambient is above the setting of the ODT (warm position), 24 volts will be supplied to terminal 1 of the ODT ⑥, energizing the compressor contactor (CC) ② and outdoor fan motor (ODM) ⑧. The first stage heat call will also energize the "G" circuit starting the indoor fan motor.

If the outdoor ambient is below the ODT setting (cold position), 24 volts will be supplied to terminal 3 of the ODT ⑥, supplying 24 volts to the "W" circuit initiating a call for gas heat operation. The gas heat will operate until the first stage of the thermostat is satisfied or the outdoor thermostat (ODT) switches to the warm position, de-energizing the gas heat "W" circuit and switching the unit back to heat pump operation.

Defrost Sequence-Restricted Mode

The defrost control (DFC) ④ initiates a defrost and energizes the switchover valve ④ and supplies 24 volts to the "O" terminal of the relay board ③ energizing the "K2" relay. The normally open "K2" relay contacts (terminals 1 and 3) ④⑤ will close connecting the "Y" circuit to terminal ③ of the outdoor thermostat ⑥. Should the outdoor thermostat switch to the cold position during a defrost cycle, the compressor will be locked in until the defrost cycle is complete.

Emergency Heat Mode

In restricted and non-restricted mode, 24 volts will be supplied from "X2" on the indoor thermostat ⑤ to the "W" terminal on the ignition control ③, initiating a call for gas heating operation.

The thermostat system switch disconnects the "Y" circuit when moved to the "emergency heat position".

The gas heat will operate until the first stage call for heat is satisfied.

IGNITION TABLES				
DIP SWITCH SETTINGS			LED DIAGNOSTIC INDICATOR	
Cool Fan OFF	Heat Fan OFF	Heat Fan ON	Flashing Slow	Normal No Call For Heat
Delay (Seconds)	Delay (Seconds)	Delay (Seconds)	Flashing Fast	Normal Call For Heat
SW2 OFF 0	SW1 OFF 60	Fixed 45	Continuous ON	Replace Control
SW2 ON 80*	SW1 ON 90*		Continuous OFF	Check Power
			2 Flashes	System Lockout (No Flame)
			3 Flashes	Pressure Switch Problem
			4 Flashes	High Limit (TCO) Open
			5 Flashes	Flame Sensed With Gas Valve Off
			6 Flashes	Flame Rollout Switch (FL) Open
			7 Flashes	W1 and W2 Reversed
				*Factory Setting

① DCX-F models have electronic time-temperature defrost controls and DCY-F models use demand defrost controls as shown.

Demand Defrost System – Dual Fuel System Only

Defrost Control

The demand defrost control measures heat pump outdoor ambient temperature with a sensor located outside the outdoor coil. A second sensor located on the outdoor coil is used to measure the coil temperature. The difference between the ambient and the colder coil temperature is the difference or delta-T measurement. This delta-T measurement is representative of the operating state and relative capacity of the heat pump system. By measuring the change in delta-T, we can determine the need for defrost. The coil sensor also serves to sense outdoor coil temperature for termination of the defrost cycle.

Fault Detection

A fault condition is indicated by the flashing light on the defrost control inside the heat pump control box.

In normal operation, the defrost control light will flash once each second.

If the light is flashing more than once per second or not-at-all, refer to the DEMAND DEFROST CONTROL CHECKOUT on the last page of this manual.

Pin Identification

NORM. – Normal (The **RED TEST WIRE**, as shipped, is **unattached** to any pin. In this position, the default condition is normal operation. However, after checking for proper operation, the wire should be returned to the Normal Pin.)

TST. = Test (Red test wire in this position speeds up all defrost board timings.)

FRC. DFT. = Forced Defrost (Touch the red test wire to this pin for ten (10) seconds to initiate a forced defrost. Return wire to the Normal pin after defrost initiates.)

Procedure For Testing Sensors

Measure the temperature the subject sensor is exposed to. If the sensor is mounted on a tube, place the lead on an Annie A-8 (or equiv.) temperature tester on the same tube near the sensor and insulate the bulb.

Unplug the sensor and measure the resistance with a good quality ohmmeter (Simpson 260 or equiv.). Read the value as quickly as possible to prevent the meter current from changing the resistance reading.

Using the chart on the right, locate (as close as possible) the actual sensor temperature. The measured resistance should be relatively close to the resistance value shown in the chart.

Example:

Sensor temp. = 19°F

Measured Resistance = 46K ohms

This sensor is good since the measured value is relatively close to the chart value.

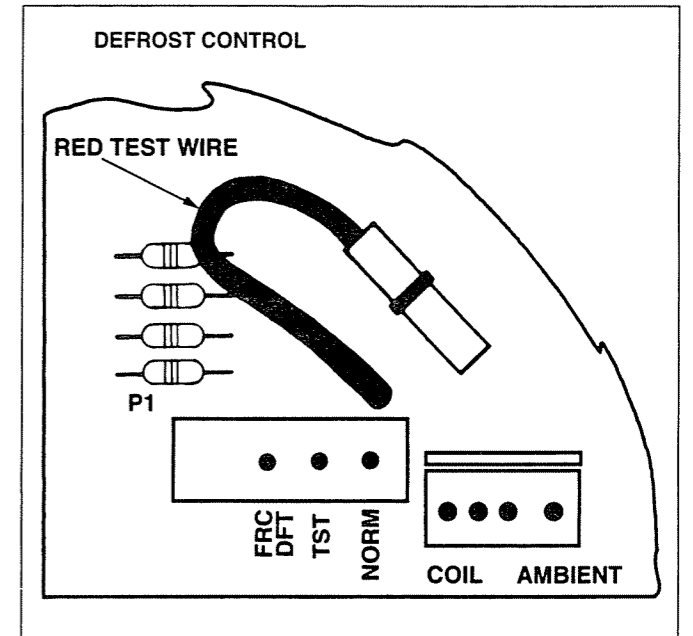

Defrost Control Checkout

Normal operation requires:

- LED on board flashing 1 time/second
- 24V AC between R & B
- 24V AC between Y & B **with compressor operating**
- Defrost initiation when test wire is moved to "Forced Defrost" pin, then return to "Normal Pin."

If a defrost control problem is suspected, proceed to DEMAND DEFROST CONTROL CHECKOUT inside the back cover.

Temp °F	Resistance (K)
88	7.85
81	8.85
75	10.24
70	11.59
65	13.14
59	15.32
55	16.93
50	19.41
45	22.20
41	24.76
36	28.45
32	31.84
25	37.50
19	46.44
14	53.94
10	57.64
5	67.06
0	78.05

YCC-F/YCX-F Gas Electric Sequence of Operation

Hamilton Standard Single Stage Spark Ignition – CNT-1634

When the service disconnect ⑫ is in the "on position", 230 volts is supplied from the line voltage input leads "L1 and L2" ⑬ to the primary side of the low voltage control transformer (TNS1) ⑭. 24 volt power is supplied from the transformer secondary ⑮ to the ignition control (IGN) "R" and "B" terminals ⑯⑰. Power is also supplied to the "RC" and "RH" terminals of the indoor thermostat ⑱. The red diagnostic L.E.D. ⑳ on the ignition control will begin flashing once per second (slow flash) indicating that the control is receiving 24 volts and awaiting a call for heat.

On a call for heat, the indoor thermostat contacts "Heat-1" ㉑ will close. 24 volt power will be supplied from the thermostat "W1" terminal ㉒, to the "W" terminal on the ignition control ㉓ and the fan speed relay coil (F) ㉔. The fan speed relay contacts ㉕②⑥ will change position and a circuit will be completed to the selected heating speed. (Fan speed relay is used on YCX018 – 042 models only.)

The ignition control will perform a self-check routine and then check the limit switch (TCO) for normally closed contacts ㉗, the flame roll-out fuseable link (FL) for continuity ㉘, and the pressure switch (PS) for normally open contacts ㉙.

With all safeties and switches in their proper position, the control will close the inducer relay contacts ㉚, energizing the combustion fan motor (CFM) ㉛. The red diagnostic L.E.D. ⑳, will also begin flashing twice per second (fast flash) indicating a call for heat.

As the combustion fan motor (CFM) ㉛ comes up to speed, the normally open pressure switch contacts (PS) ㉜ will close. The control will initiate a 15 second combustion fan motor prepurge and then simultaneously energize the spark ignitor probe (IP) ㉝ and the main gas valve (GV) ㉞.

The ignitor probe (IP) ㉝ will spark for a minimum of 2 seconds and a maximum of 7 seconds. Once the flame detector (FD) ㉟ senses a flame current signal of .5 microamps or greater, the ignitor will stop sparking and the 45 second heating fan on delay timer will begin. The indoor blower motor (IDM) will be energized at the end of the 45 second fan delay when the normally open "L1" and "IDM" contacts close ㊱, supplying 230 volts to the indoor blower motor.

When the thermostat is satisfied, the "Heat 1" contacts ㉑ will open, removing power from the "W" terminal on the ignition control (IGN) ㉓ and the fan speed relay coil (F) ㉔. The main gas valve (GV) ㉞ will close instantly stopping gas flow to the burners. The flame detector (FD) ㉟ will sense the loss of flame current and begin the 5 second combustion fan motor postpurge ㊲ and the 60 or 90 second heating fan off delay. The heating fan off delay is field selectable by setting the dip switches on the ignition control ㉟.

IGNITION TABLES		
DIP SWITCH SETTINGS		
Cool Fan OFF	Heat Fan OFF	Heat Fan ON
Delay (Seconds)	Delay (Seconds)	Delay (Seconds)
SW2 OFF 0	SW1 OFF 60	Fixed 45
SW2 ON 80*	SW1 ON 90*	
*Factory Setting		
LED DIAGNOSTIC INDICATOR		
Flashing Slow	Normal No Call For Heat	
Flashing Fast	Normal Call For Heat	
Continuous ON	Replace Control	
Continuous OFF	Check Power	
2 Flashes	System Lockout (No Flame)	
3 Flashes	Pressure Switch Problem	
4 Flashes	High Limit (TCO) Open	
5 Flashes	Flame Sensed With Gas Valve Off	
6 Flashes	Flame Rollout Switch (FL) Open	

DCX/DCY-F Dual Fuel – Non-Restricted Wiring Schematic

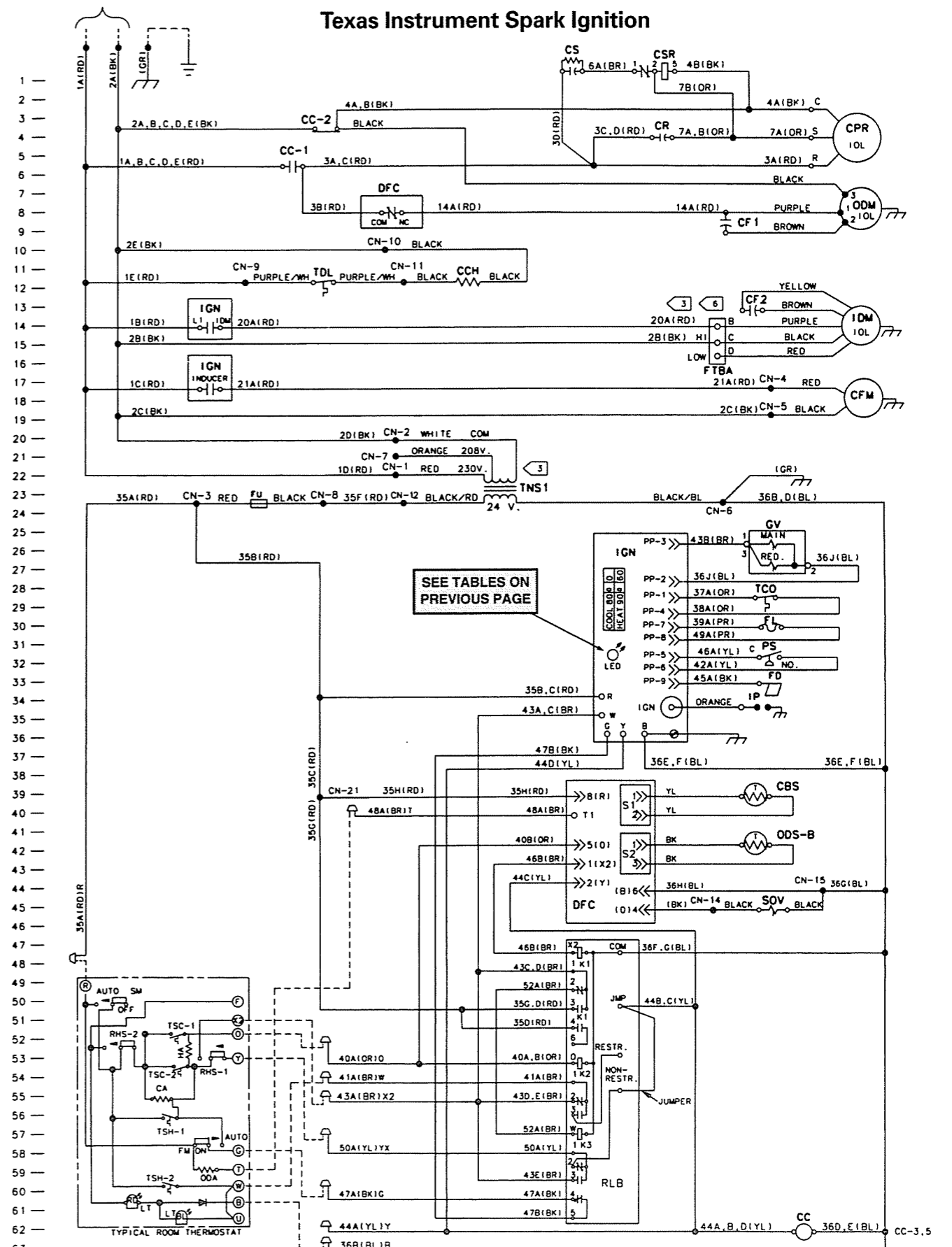

DCX/DCY-F Dual Fuel – Non-Restricted Operation

Texas Instrument Spark Ignition

Non-Restricted Mode (As shipped from the factory)

During non-restricted operation, the heat pump will be operated during a first stage call for heat. Upon a second stage heat call, the heat pump is cut off and the gas heat is operated under control of first stage until both stages of heat are satisfied. Heat pump operation will resume upon the next first stage call for heat.

Non-Restricted Sequence of Operation

Upon a first stage call for heat, 24 volts from the indoor thermostat "Y" terminal will be supplied through the normally closed K3 relay contacts on the relay board (terminals 1 and 2) to the compressor contactor coil (CC) ②, closing the CC-1 contacts ⑥, energizing the compressor (CPR) ④ and the outdoor fan motor (ODM) ⑧. 24 volts will also be supplied from the indoor thermostat "G" terminal through the normally closed K3 relay contacts (terminals 4 and 5) on the relay board (RLB) ⑥②, to the "G" terminal on the ignition control (IGN) ③⑥. The ignition control "L1 and IDM" contacts will close energizing the indoor blower motor ⑭. First stage heat pump operation is now running.

When the indoor temperature drops 1-1/2 degrees there will be a second stage call for heat. 24 volts will be supplied from the thermostat "W" terminal ⑥⑩ through the relay board (RLB) normally closed "K2" relay contacts (terminals 1 and 2) ⑤④⑤⑤ to the "W" terminal of the ignition control ③④, initiating a call for gas heat. At the same time, 24 volts are supplied through the normally closed "K1" relay contacts (terminals 1 and 2) ④⑧④⑨ on the relay board to the "W" terminal on the relay board ⑤⑦, energizing the "K3" relay. The normally closed "K3" relay contacts will open (terminals 1 and 2) ⑤⑧⑤⑨, breaking the 24 volt "Y" signal to the compressor contactor coil (CC) ②. The CC-1 contacts will open ⑤, de-energizing the compressor and outdoor fan motor. The normally closed K3 relay contacts (terminals 4 and 5) ⑥①⑥② will open, breaking the 24 volt "G" signal to the ignition control, de-energizing the indoor blower motor. The normally open K3 contacts (terminals 1 and 3) will close ⑤⑨⑥⑩, locking in the "W" heating circuit under control of the first stage (Y) until the first stage call for heat is satisfied.

IGNITION TABLES		
DIP SWITCH SETTINGS		LED DIAGNOSTIC INDICATOR
Cool Fan OFF	Heat Fan OFF	Heat Fan ON
Delay (Seconds)	Delay (Seconds)	Delay (Seconds)
SW2 OFF 0	SW1 OFF 60	Fixed 45
SW2 ON 80*	SW1 ON 90*	
*Factory Setting		
Flashing Slow	Normal No Call For Heat	
Flashing Fast	Normal Call For Heat	
Continuous ON	Replace Control	
Continuous OFF	Check Power	
2 Flashes	System Lockout (No Flame)	
3 Flashes	Pressure Switch Problem	
4 Flashes	High Limit (TCO) Open	
5 Flashes	Flame Sensed With Gas Valve Off	
6 Flashes	Flame Rollout Switch (FL) Open	
7 Flashes	W1 and W2 Reversed	

YCC-F/YCX-F Wiring Schematic

Hamilton Standard Single Stage Spark Ignition – CNT-1634

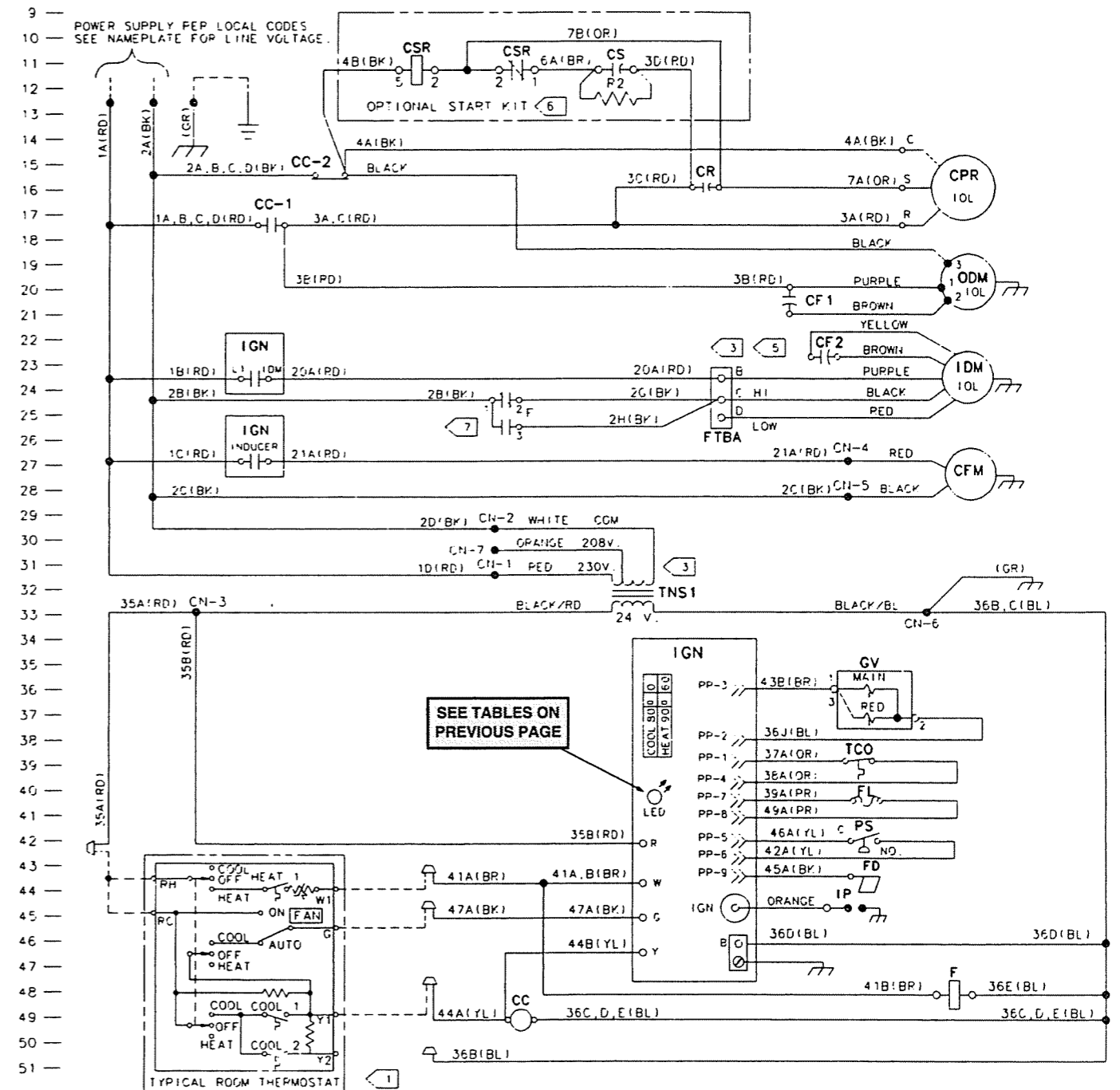

DCX/DCY-F Dual Fuel – Non-Restricted Operation

Hamilton Standard Spark Ignition

Non-Restricted Mode (As shipped from the factory)

During non-restricted operation, the heat pump will be operated during a first stage call for heat. Upon a second stage heat call, the heat pump is cut off and the gas heat is operated under control of first stage until both stages of heat are satisfied. Heat pump operation will resume upon the next first stage call for heat.

Non-Restricted Sequence of Operation

Upon a first stage call for heat, 24 volts from the indoor thermostat "Y" terminal will be supplied through the normally closed K3 relay contacts on the relay board (terminals 1 and 2) to the compressor contactor coil (CC) ⑥, closing the CC-1 contacts ⑥, energizing the compressor (CPR) ④ and the outdoor fan motor (ODM) ③. 24 volts will also be supplied from the indoor thermostat "G" terminal through the normally closed K3 relay contacts (terminals 4 and 5) on the relay board (RLB) ⑥②, to the "G" terminal on the ignition control (IGN) ③⑨. The ignition control "L1 and IDM" contacts will close, energizing the indoor blower motor ⑭. First stage heat pump operation is now running.

When the indoor temperature drops 1-1/2 degrees, there will be a second stage call for heat. 24 volts will be supplied from the thermostat "W" terminal ⑩ through the relay board (RLB) normally closed "K2" relay contacts (terminals 1 and 2) ⑤④⑤⑤ to the "W" terminal of the ignition control ③④, initiating a call for gas heat. At the same time, 24 volts are supplied through the normally closed "K1" relay contacts (terminals 1 and 2) ④⑧④⑧ on the relay board to the "W" terminal on the relay board ⑦, energizing the "K3" relay. The normally closed "K3" relay contacts will open (terminals 1 and 2) ⑤⑧⑤⑧, breaking the 24 volt "Y" signal to the compressor contactor coil (CC) ⑥. The CC-1 contacts will open ⑤, de-energizing the compressor and outdoor fan motor. The normally closed K3 relay contacts (terminals 4 and 5) ⑥② will open, breaking the 24 volt "G" signal to the ignition control, de-energizing the indoor blower motor. The normally open K3 contacts (terminals 1 and 3) will close ⑤⑩, locking in the "W" heating circuit under control of the first stage (Y) until the first stage call for heat is satisfied.

IGNITION TABLES		
DIP SWITCH SETTINGS		LED DIAGNOSTIC INDICATOR
Cool Fan OFF	Heat Fan OFF	Heat Fan ON
Delay (Seconds)	Delay (Seconds)	Delay (Seconds)
SW2 OFF 0	SW1 OFF 60	Fixed 45
SW2 ON 80*	SW1 ON 90*	
*Factory Setting		
Flashing Slow	Normal No Call For Heat	
Flashing Fast	Normal Call For Heat	
Continuous ON	Replace Control	
Continuous OFF	Check Power	
2 Flashes	System Lockout (No Flame)	
3 Flashes	Pressure Switch Problem	
4 Flashes	High Limit (TCO) Open	
5 Flashes	Flame Sensed With Gas Valve Off	
6 Flashes	Flame Rollout Switch (FL) Open	

YCC-F/YCX-F Wiring Schematic

Texas Instrument Single Stage Spark Ignition – CNT-2216

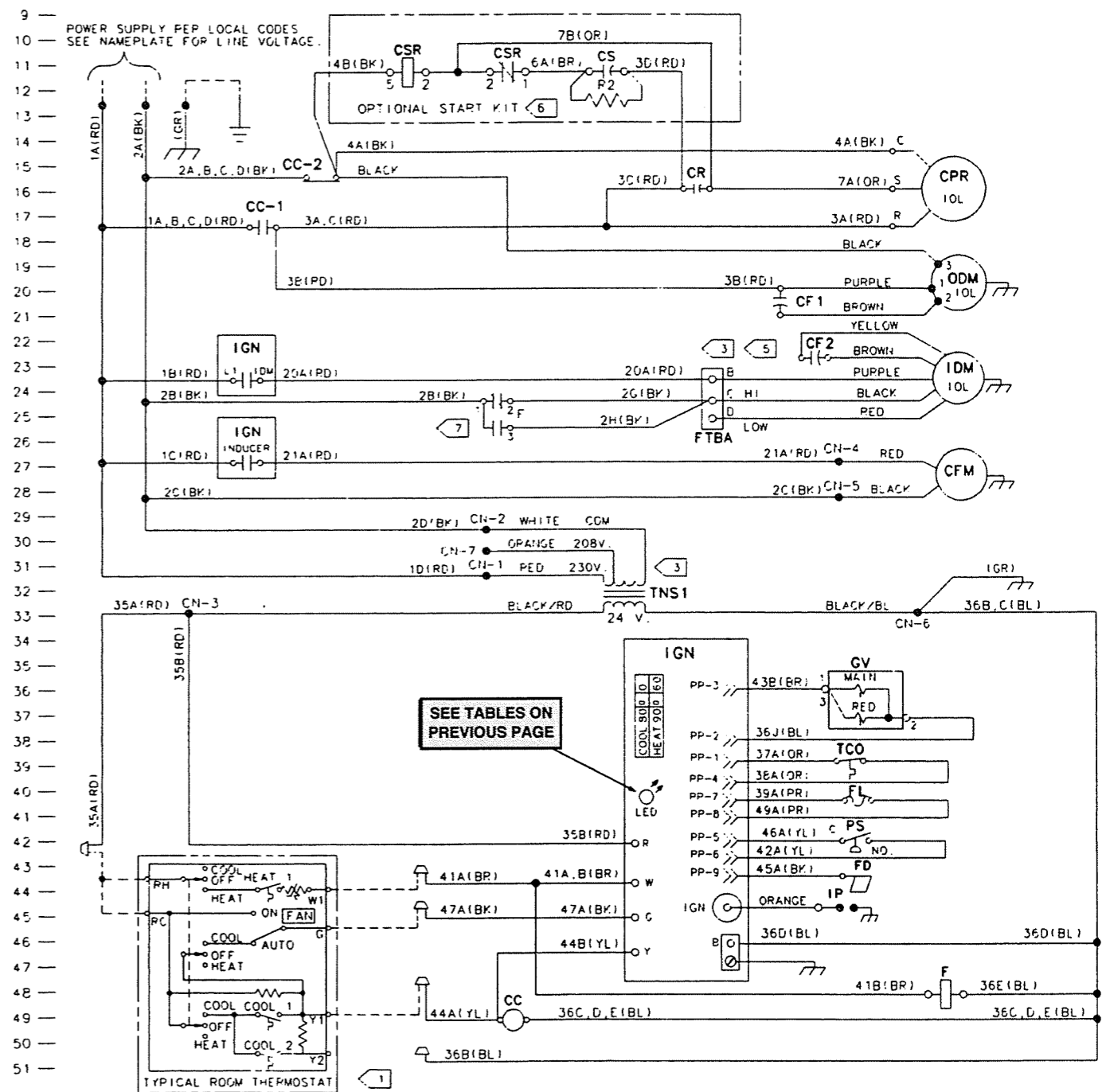

YCC-F/YCX-F Gas Electric Sequence of Operation

Texas Instrument Single Stage Spark Ignition – CNT-2216

When the service disconnect ⑫ is in the "on position", 230 volts is supplied from the line voltage input leads "L1 and L2" ⑬ to the primary side of the low voltage control transformer (TNS1) ⑳. 24 volt power is supplied from the transformer secondary ㉑ to the ignition control (IGN) "R" and "B" terminals ㉒㉓. Power is also supplied to the "RC" and "RH" terminals of the indoor thermostat ㉔. The red diagnostic L.E.D. ㉕ on the ignition control will begin flashing once per second (slow flash) indicating that the control is receiving 24 volts and awaiting a call for heat.

On a call for heat, the indoor thermostat contacts "Heat-1" ㉖ will close. 24 volt power will be supplied from the thermostat "W1" terminal ㉗, to the "W" terminal on the ignition control ㉘ and the fan speed relay coil (F) ㉙. The fan speed relay contacts ㉚㉛ will change position and a circuit will be completed to the selected heating speed. (Fan speed relay is used on YCX018 – 042 models only.)

The ignition control will perform a self-check routine and then check the limit switch (TCO) for normally closed contacts ㉜, the flame roll-out fuseable link (FL) for continuity ㉝, and the pressure switch (PS) for normally open contacts ㉞.

With all safeties and switches in their proper position, the control will close the inducer relay contacts ㉟, energizing the combustion fan motor (CFM) ㊱. The red diagnostic L.E.D. ㉕, will also begin flashing twice per second (fast flash) indicating a call for heat.

As the combustion fan motor (CFM) ㊱ comes up to speed, the normally open pressure switch contacts (PS) ㉞ will close. The control will initiate a 15 second combustion fan motor prepurge and then simultaneously energize the spark ignitor probe (IP) ㉡ and the main gas valve (GV) ㉢.

The ignitor probe (IP) ㉡ will spark for a minimum of 2 seconds and a maximum of 7 seconds. Once the flame detector (FD) ㉣ senses a flame current signal of .5 microamps or greater, the ignitor will stop sparking and the 45 second heating fan on delay timer will begin. The indoor blower motor (IDM) will be energized at the end of the 45 second fan delay when the normally open "L1" and "IDM" contacts close ㉑, supplying 230 volts to the indoor blower motor.

When the thermostat is satisfied, the "Heat 1" contacts ㉖ will open, removing power from the "W" terminal on the ignition control (IGN) ㉘ and the fan speed relay coil (F) ㉙. The main gas valve (GV) ㉢ will close instantly stopping gas flow to the burners. The flame detector (FD) ㉣ will sense the loss of flame current and begin the 5 second combustion fan motor postpurge ㊱ and the 60 or 90 second heating fan off delay. The heating fan off delay is field selectable by setting the dip switches on the ignition control ㉑.

IGNITION TABLES				
DIP SWITCH SETTINGS			LED DIAGNOSTIC INDICATOR	
Cool Fan OFF	Heat Fan OFF	Heat Fan ON	Flashing Slow	Normal No Call For Heat
Delay (Seconds)	Delay (Seconds)	Delay (Seconds)	Flashing Fast	Normal Call For Heat
SW2 OFF 0	SW1 OFF 60	Fixed 45	Continuous ON	Replace Control
SW2 ON 80*	SW1 ON 90*		Continuous OFF	Check Power
			2 Flashes	System Lockout (No Flame)
			3 Flashes	Pressure Switch Problem
			4 Flashes	High Limit (TCO) Open
			5 Flashes	Flame Sensed With Gas Valve Off
			6 Flashes	Flame Rollout Switch (FL) Open
*Factory Setting				

DCX/DCY-F Dual Fuel – Non-Restricted Wiring Schematic

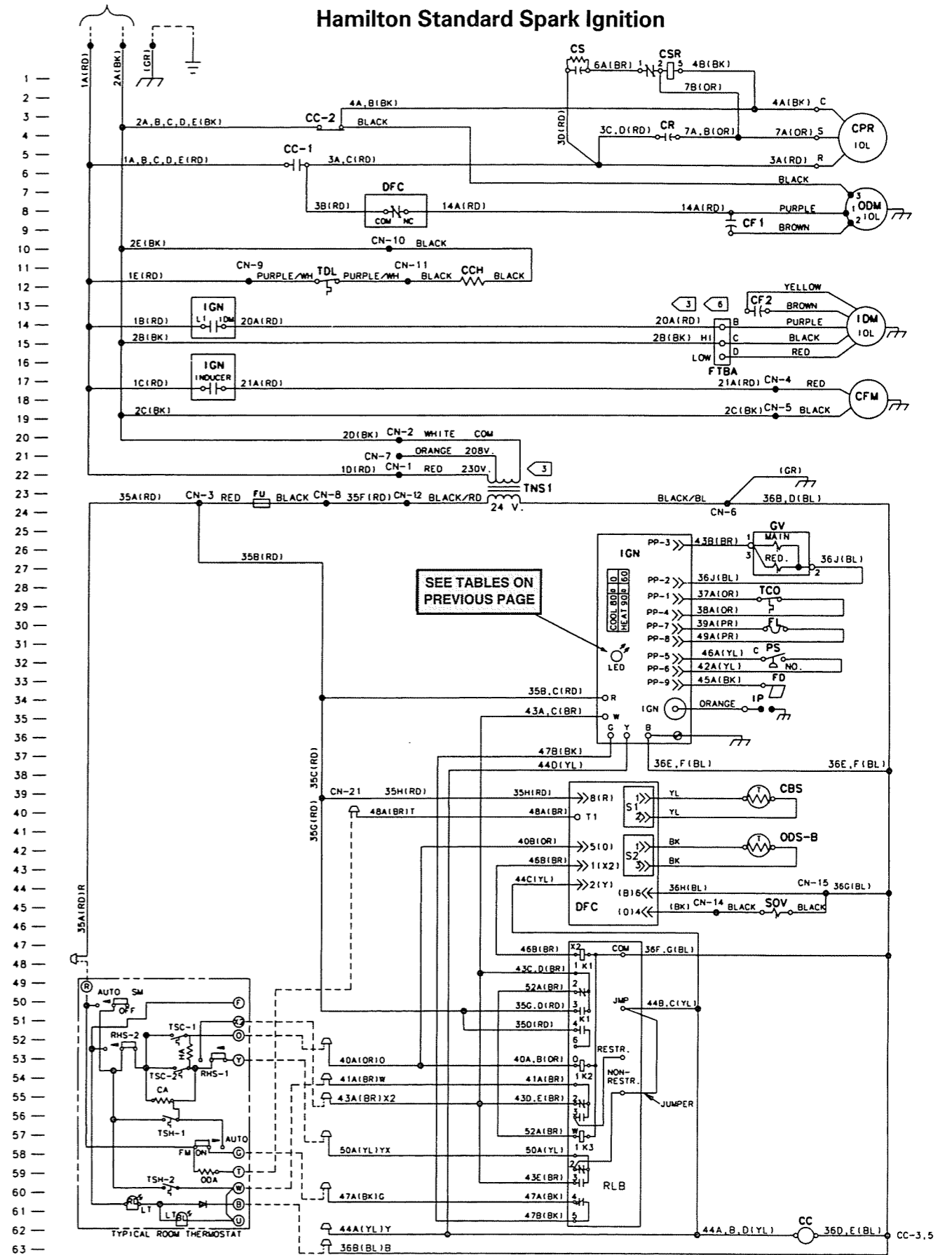

DCX-F/DCY-F Dual Fuel Restricted Operation

Hamilton Standard Spark Ignition

NOTE: Units are shipped from factory in non-restricted mode. For restricted mode, the jumper on the relay board (RLB) must be moved from the non-restricted pin to the restricted pin.

Restricted Mode (Requires outdoor thermostat)

During restricted mode of operation, the heat pump and gas furnace is controlled by the first stage of the indoor thermostat. **The second stage of the indoor thermostat (W) is not connected during the restricted mode of operation.** The first stage heat call (Y) is circuited through an outdoor thermostat (BAYSTAT033A) that will operate the heat pump when above the outdoor thermostat setting and operate the gas heat when below the outdoor thermostat setting.

Restricted-Sequence of Operation

Upon a first stage call for heat, 24 volts will be supplied from the "Y" terminal on the indoor thermostat (53) to the common terminal (terminal 2) of the outdoor thermostat (ODT) (52). If the outdoor ambient is above the setting of the ODT (warm position), 24 volts will be supplied to terminal 1 of the ODT (50), energizing the compressor contactor (CC) (54) and outdoor fan motor (ODM) (8). The first stage heat call will also energize the "G" circuit, starting the indoor fan motor.

If the outdoor ambient is below the ODT setting (cold position), 24 volts will be supplied to terminal 3 of the ODT (51), supplying 24 volts to the "W" circuit initiating a call for gas heat operation. The gas heat will operate until the first stage of the thermostat is satisfied or the outdoor thermostat (ODT) switches to the warm position, de-energizing the gas heat "W" circuit and switching the unit back to heat pump operation.

Defrost Sequence-Restricted Mode

The defrost control (DFC) (45) initiates a defrost and energizes the switchover valve (45) and supplies 24 volts to the "O" terminal of the relay board (53) energizing the "K2" relay. The normally open "K2" relay contacts (terminals 1 and 3) (54)(56) will close connecting the "Y" circuit to terminal 3 of the outdoor thermostat (51). Should the outdoor thermostat switch to the cold position during a defrost cycle, the compressor will be locked in until the defrost cycle is complete.

Emergency Heat Mode

In restricted and non-restricted mode, 24 volts will be supplied from "X2" on the indoor thermostat (51) to the "W" terminal on the ignition control (35), initiating a call for gas heating operation.

The thermostat system switch disconnects the "Y" circuit when moved to the "emergency heat position."

The gas heat will operate until the first stage call for heat is satisfied.

IGNITION TABLES				
DIP SWITCH SETTINGS			LED DIAGNOSTIC INDICATOR	
Cool Fan OFF	Heat Fan OFF	Heat Fan ON	Flashing Slow	Normal No Call For Heat
Delay (Seconds)	Delay (Seconds)	Delay (Seconds)	Flashing Fast	Normal Call For Heat
SW2 OFF 0	SW1 OFF 60	Fixed 45	Continuous ON	Replace Control
SW2 ON 80*	SW1 ON 90*		Continuous OFF	Check Power
			2 Flashes	System Lockout (No Flame)
			3 Flashes	Pressure Switch Problem
			4 Flashes	High Limit (TCO) Open
			5 Flashes	Flame Sensed With Gas Valve Off
			6 Flashes	Flame Rollout Switch (FL) Open
*Factory Setting				

① DCX-F models have electronic time-temperature defrost controls and DCY-F models use demand defrost controls as shown.

5 Ton YCY-F Two Stage Wiring Schematic

Hamilton Standard Spark Ignition - CNT-1669 Variable Speed ECM™ Indoor Motor

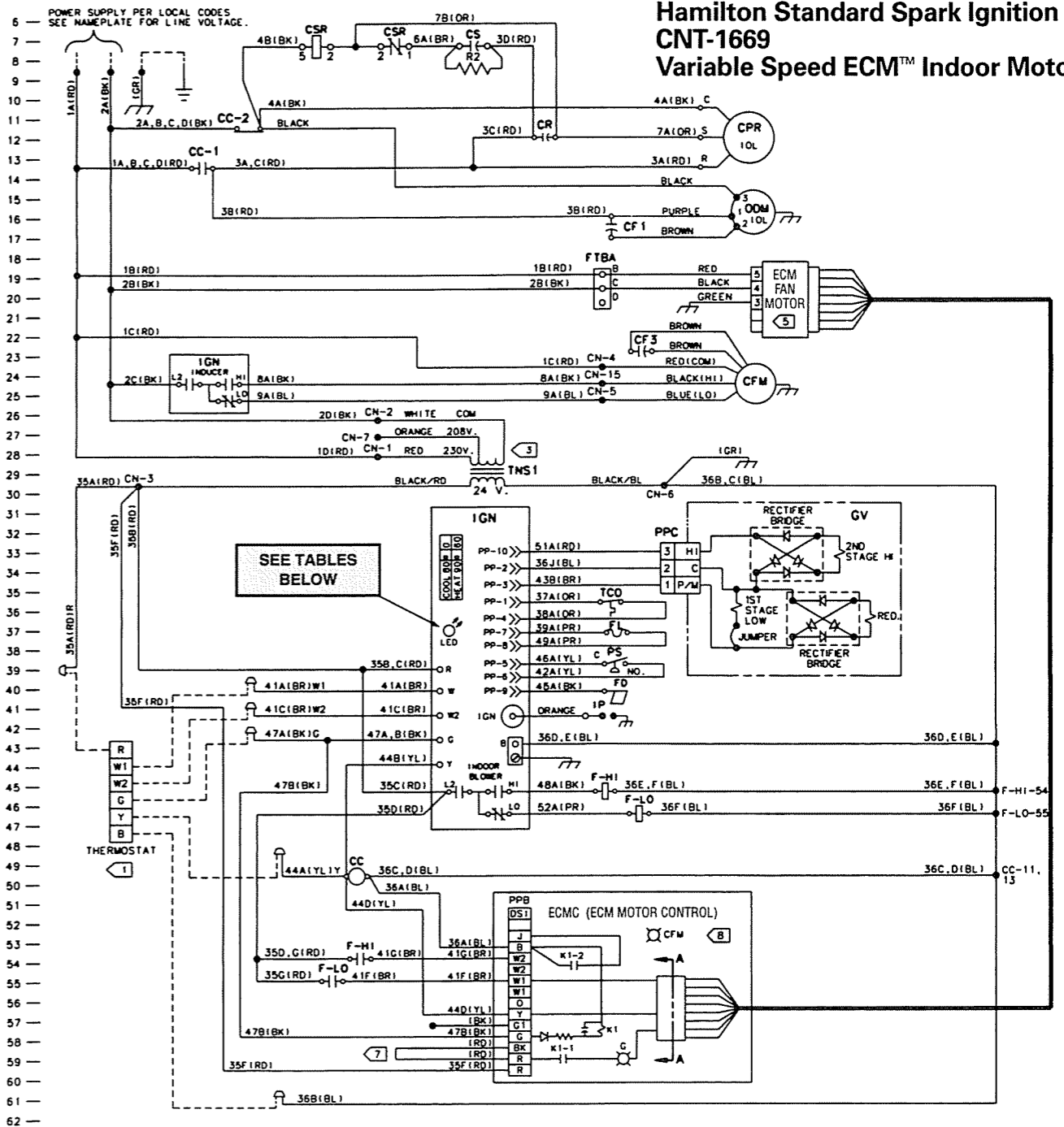

IGNITION TABLES				
DIP SWITCH SETTINGS			LED DIAGNOSTIC INDICATOR	
Cool Fan OFF	Heat Fan OFF	Heat Fan ON	Flashing Slow	Normal No Call For Heat
Delay (Seconds)	Delay (Seconds)	Delay (Seconds)	Flashing Fast	Normal Call For Heat
SW2 OFF 0	SW1 OFF 60	Fixed 45	Continuous ON	Replace Control
SW2 ON 80*	SW1 ON 90*		Continuous OFF	Check Power
			2 Flashes	System Lockout (No Flame)
			3 Flashes	Pressure Switch Problem
			4 Flashes	High Limit (TCO) Open
			5 Flashes	Flame Sensed With Gas Valve Off
			6 Flashes	Flame Rollout Switch (FL) Open
*Factory Setting				

① Remove G and Y lead from ignition control if enhanced/ramped air flow operation is selected. Units built with serial numbers of J48 or later will have the leads removed as shown.

5 Ton YCY-F Two Stage Sequence of Operation

Hamilton Standard Spark Ignition Variable Speed ECM™ Indoor Motor

When the service disconnect ⑤ is in the "On" position, 230 volts is supplied from the line voltage input leads "L1" and "L2" ⑨ to the primary side of the low voltage control transformer (TNS1) ②⑥ and to terminals "4" and "5" of the ECM™ fan motor ⑱⑲. 24 volt power is supplied from the transformer secondary ⑳ to the ignition control (IGN) "R" and "B" terminals ⑳④③. Power is also supplied to the "R" and "B" terminals ④③④⑦ of the indoor thermostat and to the "R" and "B" terminals of the ECM motor control ⑤③⑤⑨. The red diagnostic L.E.D. ⑳⑦ on the ignition control will begin flashing once per second (slow fast) indicating that the control is receiving 24 volts and awaiting a call for heat.

On a first stage call for heat, 24 volt power will be supplied from the indoor thermostat "W1" terminal ④④ to the "W" terminal ④① of the ignition control (IGN). The ignition control will perform a self check routine and then check the limit switch (TCO) for normally closed contacts ③⑤, the flame rollout fuseable link (FL) for continuity ③⑦, and the pressure switch (PS) for normally open contacts ③⑨.

With all safeties and switches in their proper position, the ignition control will open the normally closed inducer "LO" contacts and then close the normally open "L2" and "HI" inducer contacts ②④ energizing the combustion fan motor (CFM) ②④ on high speed for 5 seconds. As the combustion fan motor (CFM) comes up to speed, the control will verify that the pressure switch (PS) contacts ③⑨ have closed and switch the combustion fan motor to low speed for a 15 second prepurge by opening the "HI" speed inducer relay contacts ②④ and closing the "LO" speed inducer relay contacts ②⑥.

The control will then simultaneously energize the spark ignitor probe (IP) ④① and supply 24 volts to terminals "1" and "2" on the gas valve ③③④, energizing the first stage (low fire) of the gas valve ③③.

The ignitor probe (IP) ④① will spark for a minimum of 2 seconds and a maximum of 7 seconds. Once the flame detector (FD) ④① senses a flame current signal of .5 microamps D.C. or greater, the ignitor (IP) will stop sparking and the 45 second heating fan on delay timer will begin. The ECM™ fan motor ⑲ will be energized after 45 seconds when the ignition control (IGN) closes the normally open "L2" blower relay contacts ④⑤, supplying 24 volts through the normally closed "LO" indoor blower contacts ④⑤, energizing the "F-LO" relay coil ④⑥. The normally open "F-LO" relay contacts ⑤⑤ will close, supplying 24 volts to the "W1" terminal of the ECM motor control ⑤⑤ energizing the ECM fan low heat speed.

With first stage operating, a second stage call for heat will supply power from the "W2" terminal of the thermostat ④⑤ to the "W2" terminal of the ignition control ④①. The combustion fan motor will switch to high speed as the "LO" speed inducer contacts open ②⑥ and the normally open "HI" speed inducer relay contacts close ②④. The second stage gas valve ③③ will also be energized by supplying 24 volts to terminal "3" (HI) on the gas valve. The ECM™ fan ⑲ will be switched to "HI" after 30 seconds. The ignition control's normally open "HI" speed indoor blower relay contacts ④⑤ will close and the "LO" speed indoor blower contacts will open ④⑥, energizing the "F-HI" relay coil ④⑤. The "F-HI" relay contacts will close, supplying 24 volts to the "W2" terminal on the ECM motor control ⑤④, energizing the ECM™ fan high heat speed.

When second stage is satisfied, the combustion fan motor (CFM) will be switched back to "low" speed and the 2nd stage gas valve ③③ will be de-energized. The ECM™ fan motor will be switched back to low speed after 30 seconds. The unit will continue to operate in 1st stage operation as long as there is a call for heat.

Once first stage is satisfied, the 24 volt signal will be removed from the "W" terminal of the ignition control ④①. The first stage gas valve will close, instantly stopping gas flow to the burners. The flame detector will sense the loss of flame current and begin the 5 second combustion fan motor post purge, and the 60 or 90 second heating fan off delay timer. The "L2" inducer relay contacts will open ②④ after the 5 second post purge de-energizing the combustion fan motor. The "L2" blower relay contacts ④⑤ will open, de-energizing the ECM™ fan motor after the 60 or 90 second heating fan off delay period.

DCX-F/DCY-F Restricted Mode Wiring Schematic

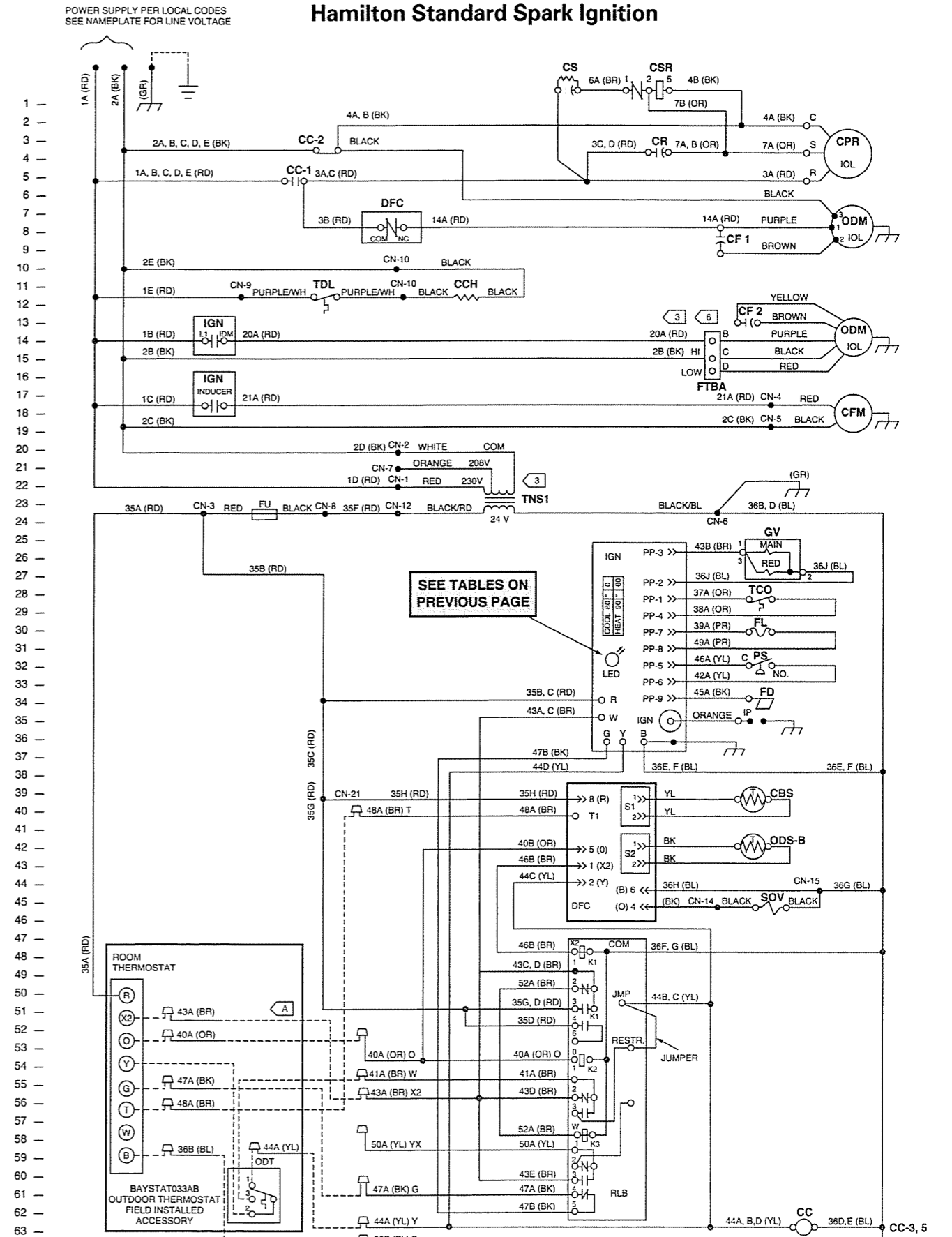

YCY-F Two Stage Sequence of Operation

Hamilton Standard Spark Ignition

When the service disconnect ⑫ is in the "on" position, 230 volts is supplied from the line voltage input leads "L1" and "L2" ⑬ to the primary side of the low voltage control transformer (TNS1) ⑳⑳. 24 volt power is supplied from the transformer secondary ㉑ to the ignition control (IGN) "R" and "B" terminals ㉒⑹. Power is also supplied to the "R" and "B" terminals ㉓⑹ of the indoor thermostat. The red diagnostic L.E.D. ㉔ on the ignition control will begin flashing once per second (slow fast) indicating that the control is receiving 24 volts and awaiting a call for heat.

On a first stage call for heat, 24 volt power will be supplied from the indoor thermostat "W1" terminal ㉕ to the "W" terminal ㉖ of the ignition control (IGN). The ignition control will perform a self check routine and then check the limit switch (TCO) for normally closed contacts ㉗, the flame rollout fuseable link (FL) for continuity ㉘, and the pressure switch (PS) for normally open contacts ㉙.

With all safeties and switches in their proper position, the control will open the normally closed inducer "LO" contacts ㉚ and then close the normally open "L2" and "HI" inducer contacts ㉛ energizing the combustion fan motor (CFM) ㉜ on high speed for 5 seconds. As the combustion fan motor (CFM) comes up to speed, the control will verify that the pressure switch (PS) contacts ㉜ have closed and switch the combustion fan motor to low speed for a 15 second prepurge by opening the "HI" speed inducer relay contacts ㉝ and closing the "LO" speed inducer relay contacts ㉞.

The control will then simultaneously energize the spark ignitor probe (IP) ㉟ and supply 24 volts to terminals "1" and "2" on the gas valve ㊱⑹, energizing the first stage (low fire) of the gas valve ㊲⑹.

The ignitor probe (IP) will spark for a minimum of 2 seconds and a maximum of 7 seconds. Once the flame detector (FD) ㊳ senses a flame current signal of .5 microamps D.C. or greater, the ignitor (IP) will stop sparking and the 45 second heating fan on delay timer will begin. The indoor blower motor (IDM) ㊴ will be energized after 45 seconds when the control closes the normally open "L2" blower relay contacts ㊵, supplying 230 volts through the normally closed "LO" blower contacts ㊶ to the "LO" speed winding of the indoor blower motor ㊷.

With first stage operating, a second stage call for heat will supply power from the "W2" terminal of the thermostat ㊸ to the "W2" terminal of the ignition control ㊹. The combustion fan motor will switch to high speed as the "LO" speed inducer contacts open ㊺ and the normally open "HI" speed inducer relay contacts close ㊻. The second stage gas valve ㊼ will also be energized by supplying 24 volts to terminal ㊽ "HI" on the gas valve. The indoor blower motor ㊴ will be switched to "HI" speed after 30 seconds. The normally open "HI" speed blower relay contacts ㊾ will close and the "LO" speed blower contacts will open ㊿.

When second stage is satisfied, the combustion fan motor (CFM) will be switched back to "Low" speed and 2nd stage gas valve ㊼ will be de-energized. The indoor blower motor will be switched back to low speed after 30 seconds. The unit will continue to operate in 1st stage operation as long as there is a call for heat.

Once first stage is satisfied, the 24 volt signal will be removed from the "W" terminal of the ignition control ㊹. The first stage gas valve will close, instantly stopping gas flow to the burners. The flame detector will sense the loss of flame current and begin the 5 second combustion fan motor post purge, and start the 60 or 90 second heating fan off delay timer. The "L2" inducer relay contacts will open ㊿ after the 5 second post purge period, de-energizing the "LO" speed combustion fan motor. The "L2" blower relay contacts ㊾ will open, de-energizing the low speed indoor blower after the 60 or 90 second heating fan off delay period.

YCY-F Two Stage Wiring Schematic

Hamilton Standard Spark Ignition

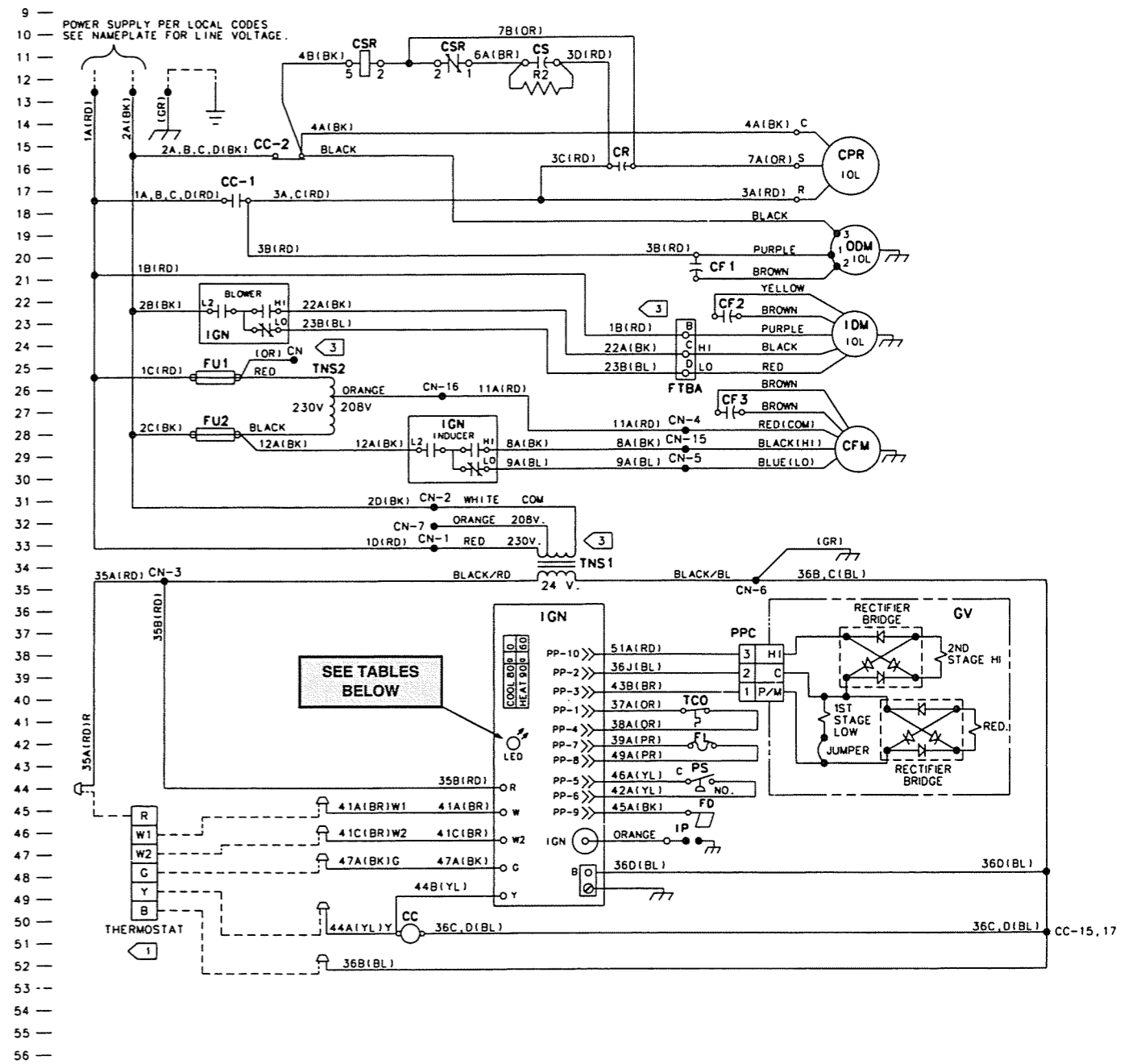

IGNITION TABLES		
DIP SWITCH SETTINGS		LED DIAGNOSTIC INDICATOR
Cool Fan OFF	Heat Fan OFF	Flashing Slow
Delay (Seconds)	Delay (Seconds)	Flashing Fast
SW2 OFF 0	SW1 OFF 60	Continuous ON
SW2 ON 80*	SW1 ON 90*	Continuous OFF
		2 Flashes
		3 Flashes
		4 Flashes
		5 Flashes
		6 Flashes
		Normal No Call For Heat
		Normal Call For Heat
		Replace Control
		Check Power
		System Lockout (No Flame)
		Pressure Switch Problem
		High Limit (TCO) Open
		Flame Sensed With Gas Valve Off
		Flame Rollout Switch (FL) Open

*Factory Setting