

40" Residential Gas Furnace Operation

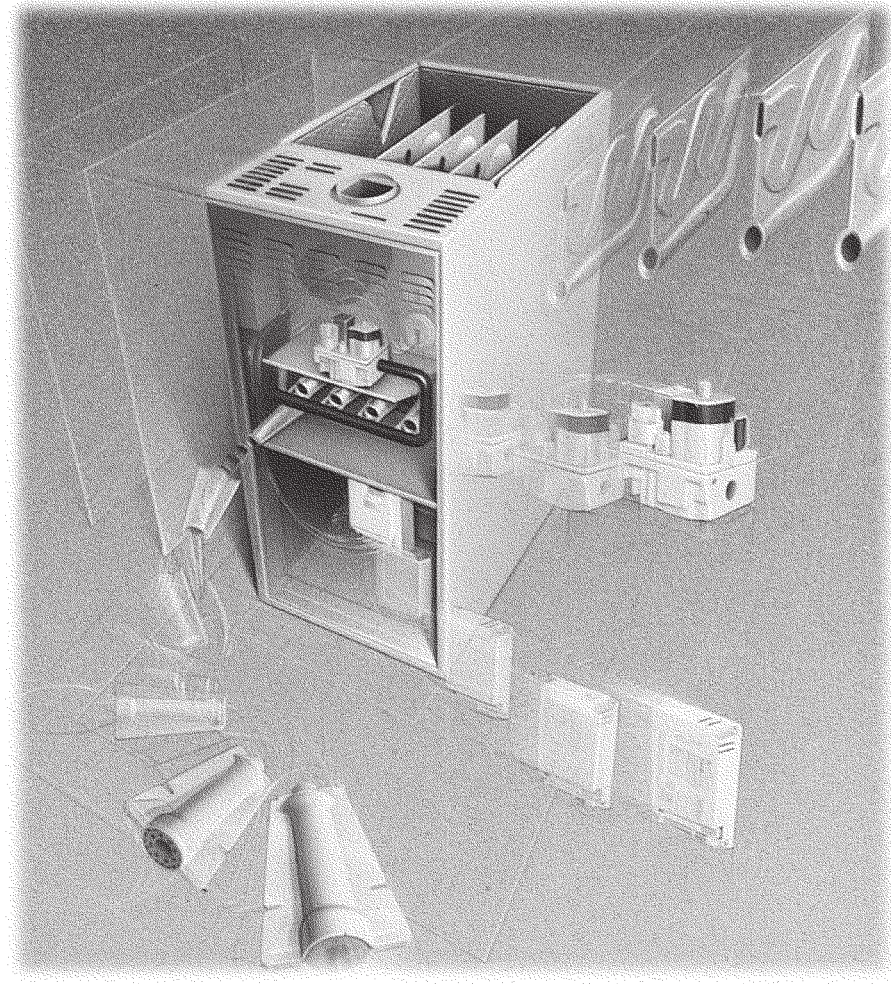

Model Evolution/Nomenclature | Heating Sequence of Operation
Schematics | Ignition Systems | Service/Troubleshooting

Preface

Air Conditioning and heating service technicians must have a working knowledge of basic electrical and refrigeration service procedures. In order to service gas furnaces, a thorough understanding of the units sequence of operation is essential. This publication is

based on White-Rogers controls and provides the narrative and schematic drawings necessary to provide this understanding for these furnaces. Also included is a description of operating principles of different ignition systems.

Contents

Model Evolution	3
Model Nomenclature	4
Component Identification – *UD/*DD-R Models	5
Component Identification – *UY/*DY-R Models	6
Integrated Furnace Controls (I.F.C.)	7
Self Diagnostic Features 50A50 and 50A51	9
Integrated Furnace Control Timing	10
Abnormal Furnace Operation – 50A50 and 50A51	11
Single Stage 50A50 Sequence of Operation	14
Wiring Schematic – Single Stage 50A50 Integrated Furnace Control	15
Two Stage 50A51-405 Sequence of Operation	16
Wiring Schematic – Two Stage Heat 50A51-405 Integrated Furnace Control	17
Two Stage Variable Speed Sequence Of Operation	18
Wiring Schematic – Two Stage Variable Speed 50A51-505/50A51-506 Integrated Furnace Control	19
Integrated Control Quick Reference	20
Furnace ECM™2 Motor Operation	21
ECM™2 Variable Speed Furnace Motor Quick Check	22
Schematic – Motor Control Board	24
Flame Rectification Principle – Measurement	25
Flame Current Tester/Simulator	26
Combustion Air Pressure Switch Check – Measurement	27
Furnace Pressure Switch Settings	28
SWT02359 and CNT03814 Installation	29

* Models maybe an A or T or F

continued

Note: This publication is general in nature and is intended for INSTRUCTIONAL PURPOSES ONLY. It is not to be used for equipment selection, application, installation, or specific service procedures.

Contents – continued

Gas Valves	30
Manifold Pressure Settings	32
Direct Vent Manifold Pressure Check	33
Determining Natural Gas Furnace Input	34
Single Stage Twinning Kit	35
Field Wiring Diagrams – Single Stage and Two Stage Thermostats	36
Two Stage Twinning Kit	37
Fields Wiring Diagram – Twinning *UD-R Furnaces	38
Single Wire Twinning – For Models with Twin Terminals	39
Radiant Sense Ignition Controls	40
Radiant Sense Ignition Control Timing	41
Identifying Radiant Sense Controls	42
Radiant Energy Sensor	43
50A52-100 Sequence of Operation	44
Wiring Schematic – Version 1 Radiant Sense Control	45
50A52-100 Sequence of Operation	46
Wiring Schematic – Version 2 Radiant Sense Control	47
50A52-100 Sequence of Operation	48
Wiring Schematic – Version 3 Radiant Sense Control	49
50A52-100/101/102 Sequence of Operation	50
Wiring Schematic – Version 4 Radiant Sense Control	51
Troubleshooting Procedures	52
• 50A50 Flow Chart 1	53
• 50A50 Flow Chart 2	54
• 50A50 Flow Chart 3	55
• 50A50 Flow Chart 4	56
• 50A50 Flow Chart 5	57
• 50A51 Flow Chart 1	58
• 50A51 Flow Chart 2	59
• 50A51 Flow Chart 3	60
• 50A51 Flow Chart 4	61
• 50A51 Flow Chart 5	62
• 50A52 Flow Chart 1	63
• 50A52 Flow Chart 2	64
• 50A52 Flow Chart 3	65
• 50A52 Flow Chart 4	66
Legends – System Wiring	67

* Models maybe an A or T or F

40" Residential Gas Furnace Evolution

- Third Quarter 1991 – *UD-R and *UD-C 40" induced draft upflow models introduced to replace the TUD-B linear burner upflow models.
- Second Quarter 1992 – *DD-R and *DD-C 40" induced draft downflow/horizontal models introduced to replace the TDD-B linear burner downflow models and the THP, THS and THD series horizontal models.
- Second Quarter 1993 – *UE 40" single stage radiant sense ignition model introduced.
- Third Quarter 1993 – *UC-C and *DC-C 40" condensing models introduced to replace the TUC-B and TDC-B linear burner condensing models. (*UC-C models convert to horizontal left, *DD-C models convert to horizontal right.)
- Fourth Quarter 1993 – *DE 40" single stage radiant sense ignition models introduced.
- Second Quarter 1994 – *UX-C and *DX-C 40" direct vent condensing models introduced to replace the *UX-B and *DX-B linear burner direct vent models.
- Third Quarter 1994 – TUJ-A 40" radiant sense ignition model introduced. Model converts to horizontal left or horizontal right and is shipped without bottom panel and filter. Model discontinued third quarter 1995.
- Fourth Quarter 1994 – *UY-R-V 40" two-stage, direct vent variable speed condensing models introduced to replace the TUC/TDC-B-V variable-speed models.
- Second Quarter 1995 – *DD-C-C Downflow/Horizontal and *UD-C-H Upflow/Horizontal models introduced. Previous upflow models were for upflow applications only. The *UD-C-H and TUE-A-H models are also approved for horizontal installation. The *DD-C-C and *UD-C-H models are equipped with the "enhanced" integrated furnace control with 120 VAC humidifier output, adaptive hot surface ignitor timing and improved fault tolerances.
- First Quarter 1996 – TUE/TDE-A-K up graded to 80% AFUE. These models have remote flame rectification ignition control systems.
- Fourth Quarter 1997 – Introduced the Silicon Nitride Ignitor and appropriate controls.

For all models equipped with the Silicon Nitride Hot Surface Ignitor, see Pub. No. 34-3405.

* Models maybe an A or T or F

Model Nomenclature

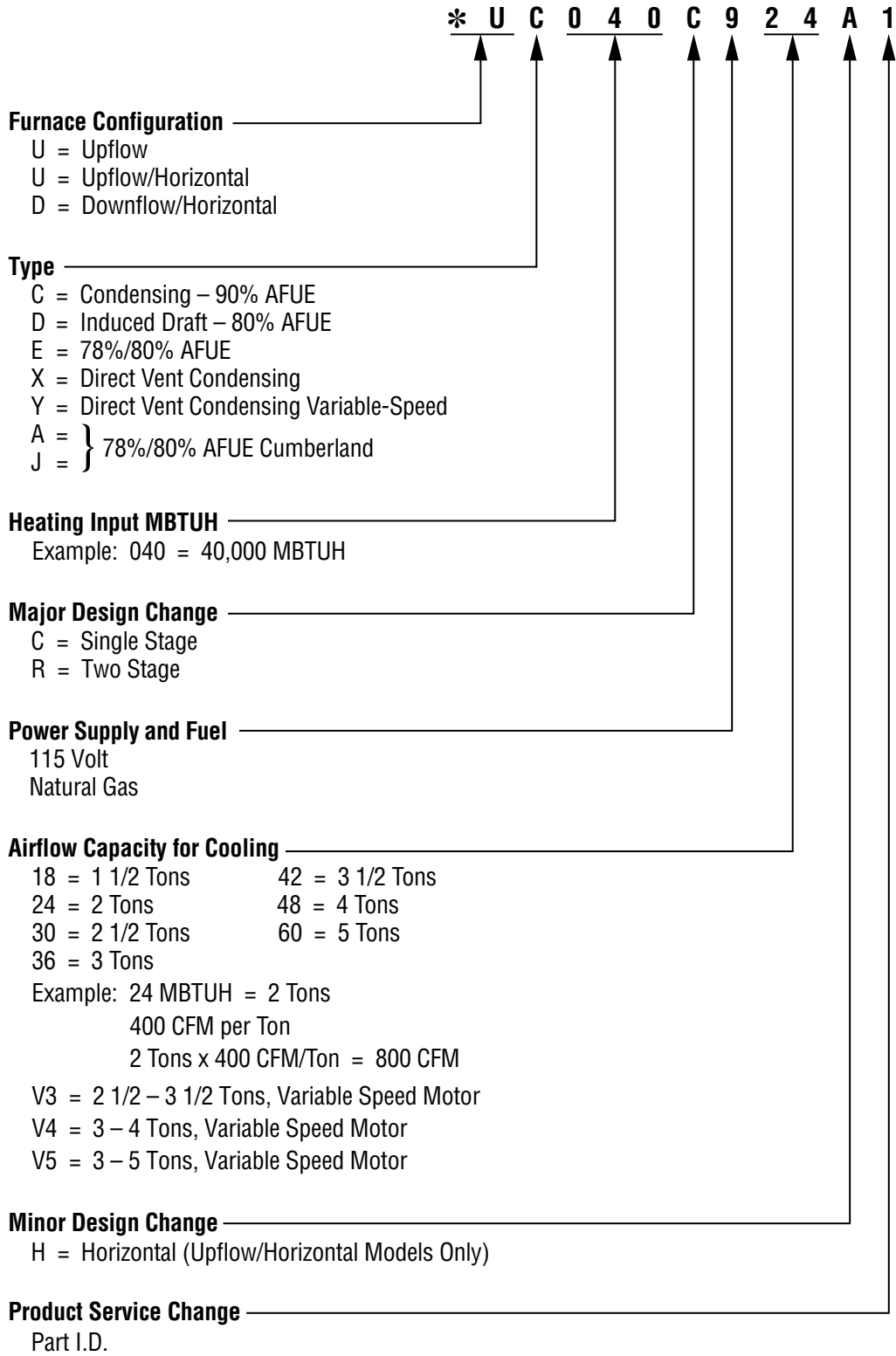

* First letter may be A or T or F

Component Identification – *UD/*DD-R Models

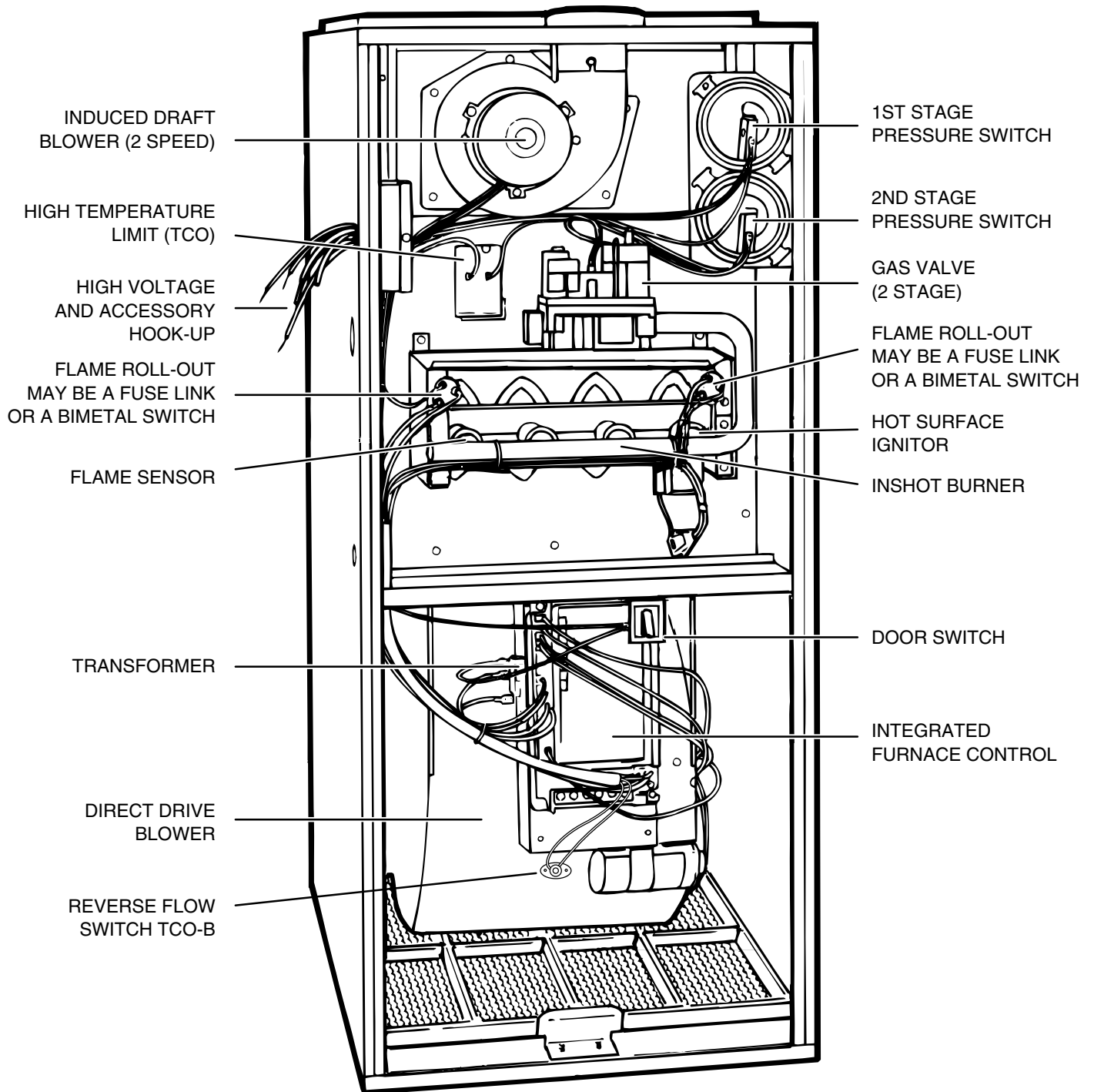

* Models maybe an A or T

Component Identification - *UY/*DY-R Models

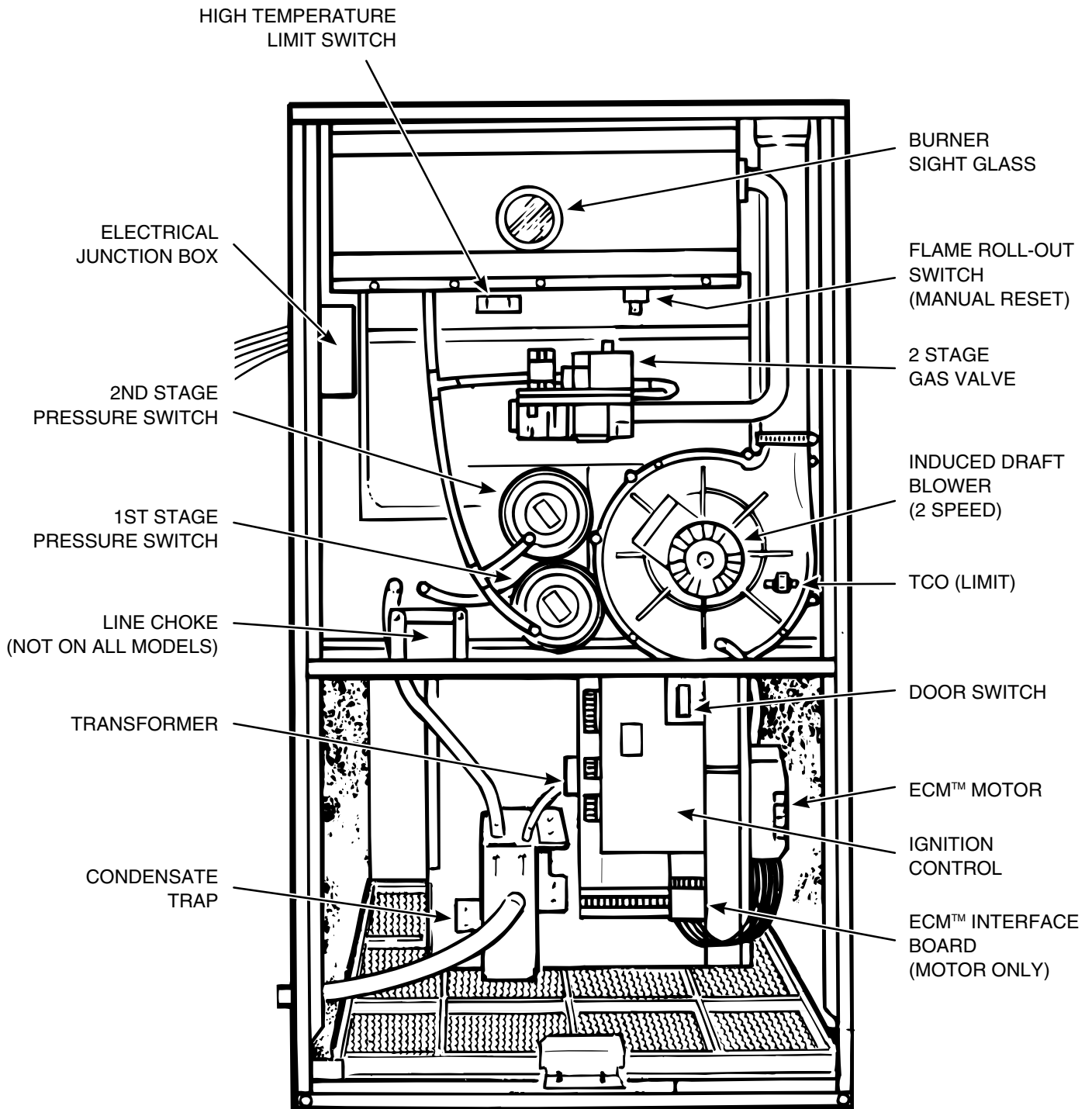

* Models maybe an A or T

White-Rodgers Integrated Furnace Controls – 50A50 & 50A51 Series

The White-Rodgers Integrated Furnace Control (I.F.C.) is an automatic ignition control module that uses microcomputer based circuitry to continuously monitor, analyze and control the proper operation of the gas burner, induced draft motor and indoor blower. The microcomputer provides continuous surveillance of the thermostat, flame sensor and safety devices to initiate automatic gas burner ignition and shutoff sequences during normal, or fault condition operation.

There are currently several versions of the White-Rodgers 50A50/50A51 Integrated Furnace Controls:

1. 50A50 Series -405 Single-Stage controls are used in *UD/*DD-C-A, B and FCA/FUA-A-A.
2. 50A50 Series -406 Single-Stage controls are used in *UC/*DC-A & B and *UX/*DX-C-A.
3. 50A50-471 and 473 Single-Stage used in *UD-C-H and *DD-C-C.
4. 50A50-472 and 474 Single-Stage used in *UC/*DC-C-C.
5. 50A50-571 Single-Stage used in *UE/*DE-A-K, FUA- and FCA-E and is part of the up-grade control system for Radiant Sense Controls, Part No. KIT 3793.
6. 50A51 Series -405 or -495 Two-Stage used in *UD/*DD-R.
7. 50A51-506 Two-Stage Variable-Speed used in *UD/*DD-R9V. 50A51-505 superseded by 50A51-506 after October 1995.
8. 50A51-506 Two-Stage Variable-Speed used in *UY/*DY-R9V.
9. 50A51-507 Two-Stage Variable-Speed used on all Variable-Speed models after September 1996.

* First letter may be A or T or F

Note: Control models 50A50-406/472 and 474 and 50A51-405/-495/-505/-506/-507 provide on-board relay switching of 120V AC system power for the optional humidifier and electronic air cleaner accessories. Control models 50A50-471/473 provides on-board relay switching of system power for the optional humidifier accessory only.

During heating cycles, the Control provides on-board relay switching of 120V AC system power for the induced draft motor, hot surface ignitor and 24V AC power for the gas valve. During heating and cooling cycles, the Control provides on-board relay switching of system power for the indoor blower motor.

Fan On

When the thermostat fan switch is in the ON position, 24V AC is applied from the thermostat "G" terminal to the I.F.C. Control "G" terminal.

The "G" call to the I.F.C. control will cause it to energize an internal relay coil. This relay's switch will close, energizing the indoor blower.

On single stage controls, the blower will run on Heating Speed. On Two-Stage I.F.C. controls, the blower will run on the low Heating Speed. On Variable-Speed models, the "G" call to the blower motor will signal it to run at 50% of the programmed cooling CFM speed.

Cooling Air Flow

When the thermostat system switch is in the COOL position and the thermostat calls for cooling, 24V AC is applied from the thermostat "Y" terminal to the I.F.C. Control "Y" terminal.

The "Y" call to the I.F.C. Control will cause it to energize an internal relay coil. This relay switch will close energizing the indoor blower on the cooling speed tap. The I.F.C. control's fan speed relays are inter-locked to prevent power from being applied to two blower motor speed taps at the same time. On Variable-Speed models, the "Y" call to the blower motor will signal it to run at 80% of the programmed cooling CFM Speed. Note: Y and BK must be jumper or humidistat connected to BK to get 100%.

If the "Y" connection is not made to the Control, the indoor blower will run on heating speed during a cooling cycle.

Cooling Blower Delay to Off

The Control provides an optional indoor blower off delay of 80 seconds in cooling cycles. The off delay is field selectable by adjusting Dip-Switch 1 to OFF except 50A50-571 Control. A jumper wire must be cut. Dip-Switch 1 **must** be in the ON position always on variable speed furnace models using 50A51-505/-506/-507 Controls. See Furnace ECM™2 Motor Operation.

White-Rodgers Integrated Furnace Controls – 50A50 & 50A51 Series

Heating Blower On and Off Delay

These controls provide a fixed 45 second indoor “blower on” delay after the flame is sensed during heating cycles. After this time delay, the indoor blower motor will be energized to run on heating speed. The Control also provides an indoor “blower off” delay. The 50A50-571 I.F.C. delay to off is not adjustable, all other 50A50 and 50A51 controls have field adjustable delays to off. The off delay time is field selectable by adjusting Dip-Switches 2 and 3 on the Control.

Dip-Switch Settings or Jumper Wire

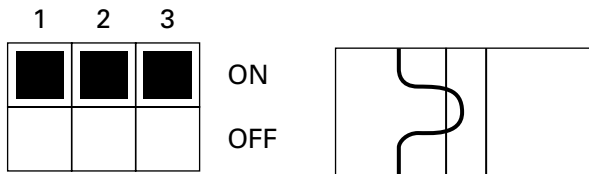

Cooling Fan Off Delay (seconds)

Switch 1/Jumper ON = 0 (Factory Setting)

Switch 1 OFF/Jumper cut = 80

Heating Fan Off Delay (seconds)

Switch 2	Switch 3	Time	Time ^①
ON	OFF	90	60
OFF	ON	120	140
ON	ON	150 ^②	100 ^②
OFF	OFF	210	180

① I.F.C. Control 50A50-473-474 and 50A51-495/507 use these harmonized delay times, 50A50-571 heating time delay is 100 seconds.

② Factory setting.

50A51-405 Control

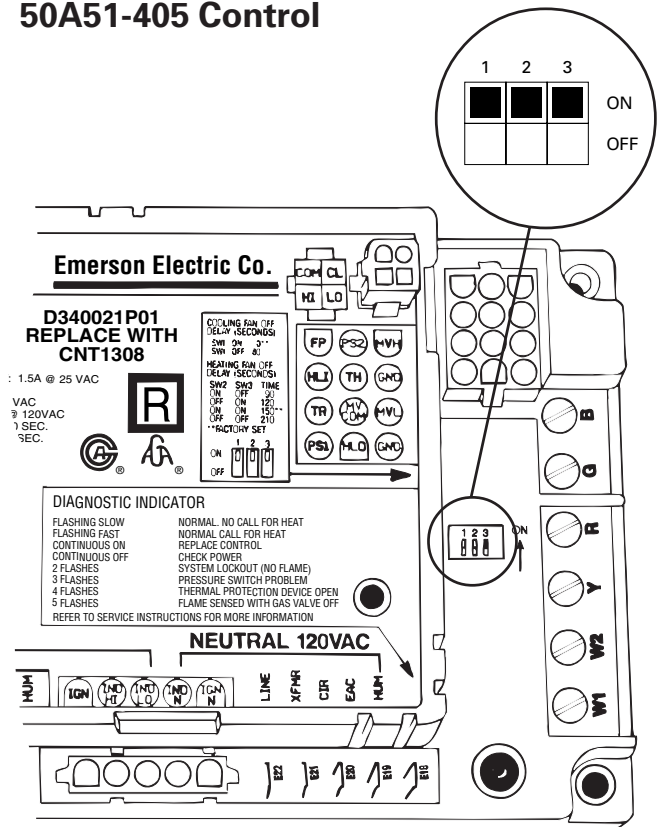

50A50-571 Control

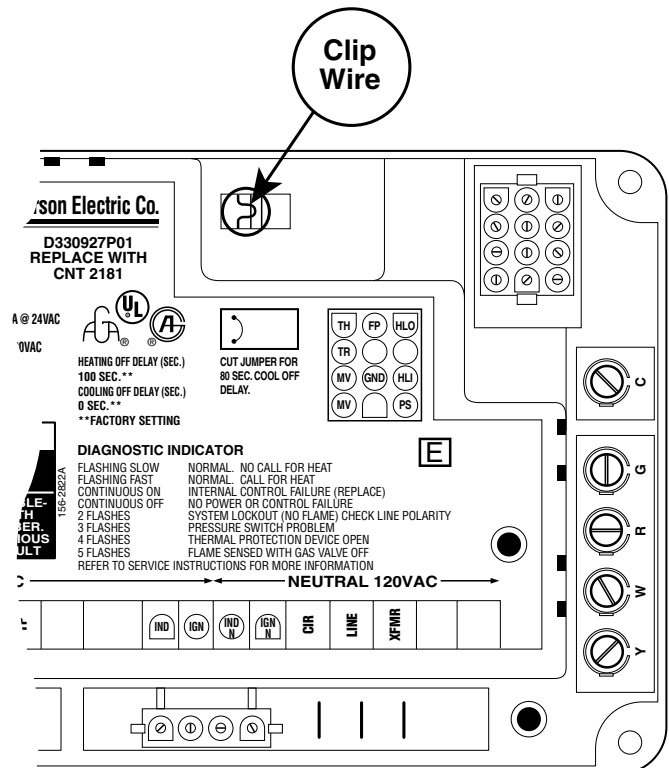

White-Rodgers Self Diagnostic Features – 50A50/50A51 Series

The integrated furnace control incorporates system fault analysis for quick gas flow shutoff, coupled with automatic ignition retry upon sensing a fault correction.

The integrated furnace control tests for internal and external faults before allowing a heating sequence to begin. The external check includes all safety devices and pressure switches, making certain that they are in their proper normally open or normally closed position. If a fault is detected by the control, it will immediately enter into a fault mode and flash the LED light according to the fault detected, see LED Flash Rate table at right. The control will remain in the fault mode until the problem is corrected. Once the fault is cleared, the control will start the heating sequence as long as the call for heat still exists.

The control has an expanded diagnostic feature that monitors system performance. If a fault is detected during operation, the control will de-energize the gas valve and flash the diagnostic LED according to the fault detected (see LED flash rate Table 3).

The control will automatically reset a lock-out due to loss of flame. See I.F.C. Timing Table for reset time, see page 10.

Important:

The control is mounted in the blower section. Do not remove blower door before checking flash rate of LED. Sight glass is provided on upflow models in the blower door panel to prevent resetting control and loss of diagnostics.

LED Flash Rate

Normal Operation

- The LED will flash for 1 second at power-up
- the LED will flash "FAST", 1/4 second "ON" and 1/4 second "OFF", during a call for heat
- The LED will flash "SLOW", 1/4 second "ON" and 3/4 seconds "OFF" with system in stand-by (power on).

Note: The LED will flash "ON" for approximately 1/4 second, then "OFF" for approximately 1/4 second. The pause between groups of flashes is approximately 2 seconds.

Fault Diagnostic

- Continuous ON – Internal Fault, or grounded sensor (Lockout)
- 2 Flashes – System Lockout – No Flame^①
- 3 Flashes – Pressure Switch Error
- 4 Flashes – Thermal Protection Device Open
- 5 Flashes – Flame Sensing With Gas Valve De-Energized (Stuck Open)

① This fault will be caused if the hot leg and neutral leg of the 120 volt A.C. power legs are reversed.

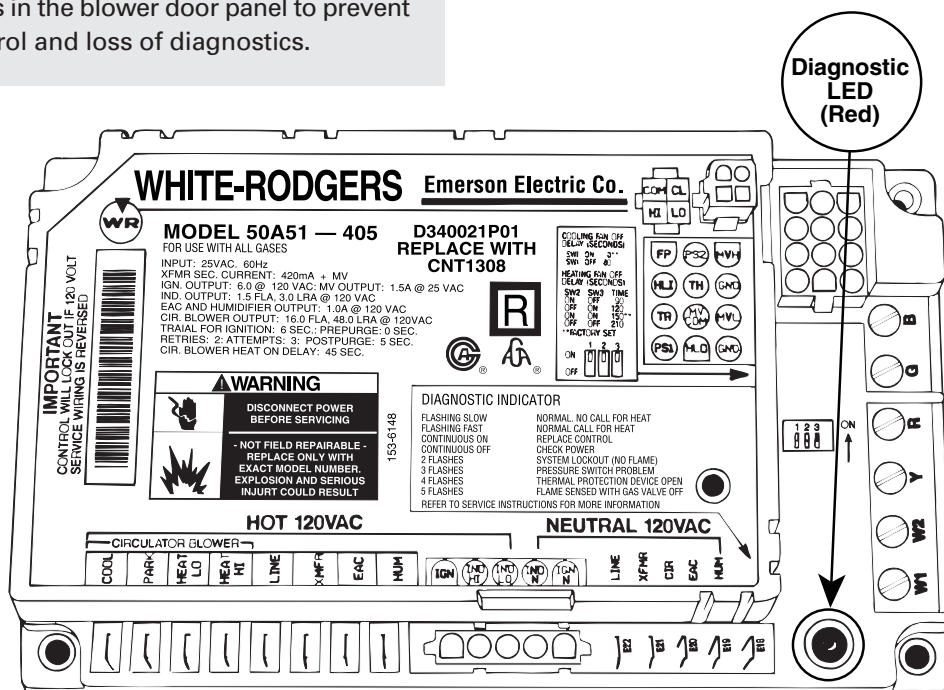

White-Rodgers Integrated Furnace Control Timing

IFC Timings

Part I.D.		Safety Times (Seconds)				Circulator Delays (Seconds)				Auto Reset				Ignitor Warm-Up (Seconds)				Accessories				
White-Rodgers Model	Revs.	Part Number	Pre Purge	Inter Purge	Post Purge	IAP	Trial for Ignition	IND Off	Heat On	Heat Off (Factory Set)	Cool On	Cool Off	No. of Retries	No. of Recycles	Reset Time (min.)	Initial Warm-Up	Retry Warm-Up	Minimum Warm-Up	Maximum Warm-Up	HUM	EAC	Twin Plug
1 Stage IFC's																						
50A50-405	E93 - E6	CNT1309	0	60	5	3	6	NA	45	90, 120, 150, 180	0	0/80	2	4	120	17	27	17	27			
50A50-406	E93 - E6	CNT1616	0	60	5	3	6	⑥	45	90, 120, 150, 180	0	0/80	2	4	120	17	27	17	27	⑤		X
50A50-471	E90 - E2	CNT1848	0	60	5	1	4	30	45	90, 120, 150, 180	0	0/80	2	4	120	17	①	11	21	⑤		
50A50-472	E90 - E2	CNT1849	0	60	5	1	4	30	45	90, 120, 150, 180	0	0/80	2	4	120	17	①	11	21	⑤		X
50A50-473	E3	CNT2182	0	60	5	1	4	30	45	60, 100, 140, 180	2	0/80	2	10	60	17	①	11	21	⑥		
50A50-474	E3	CNT2183	0	60	5	1	4	30	45	60, 100, 140, 180	2	0/80	2	10	60	17	①	11	21	⑤		X
50A50-571②	E1 - E2	CNT2181	0	60	5	1	4	30	45	100	2	0/80	2	10	60	17	①	11	21			
50A55-571⑩	E91	CNT2789	0	60	5	1	4	30	45	100	0	0/80	2	10	60	17	①	11	21			
2 Stage IFC's																						
50A51-405	E93 - E3	CNT1308	0	120	5	3	6	NA	45	90, 120, 150, 180	0	0/80	2	4	120	17	27	17	27	⑤		X
50A51-495	E3	CNT2184	0	60	5	1	4	NA	45	60, 100, 140, 180	2	0/80	2	10	60	17	①	11	21	⑤		X
50A51-505	E90	CNT1523	0	30	5	3	6	0	45	90, 120, 150, 180	0	⑦	2	4	120	17	27	17	27	⑤		X
50A51-506	E90 & 91	CNT1819	0	30	5	3	6	30	45	90, 120, 150, 180	0	⑦	2	4	120	17	27	17	27	⑤		X
50A51-507	E90	CNT2223	0	60	5	1	4	30	45	60, 100, 140, 180	0	⑦	2	10	60	17	①	11	21	⑤		X
50A61-625	E94	CNT2536	0	60	5	1	4	30	45	60, 100, 140, 180	0	⑦	2	10	60	20	⑨	11	21	⑤		X

Notes:

- The ignitor starts with a 17 second heat-up timing. After 64 successful cycles, the timing will be shortened each cycle by 1 second until 11 seconds is reached. If a cycle fails to prove flame, the time will increase by 2 seconds to 13 seconds, then to 15 and so on, up to 21 seconds. 11 min. and 21 max. If a lockout or power loss occurs, the count starts over.
 - 50A50-571 IFC uses a jumper that must be cut to obtain Cool Off Delay. Factory shipped with Jumper not cut = No Cool Off Delay.
 - IAP = Ignition After Proving. (The amount of time that the ignitor remains energized after the Main Burner Flame is sensed).
 - IND Off = Time that the inducer is deenergized after a fault (LED 3 Flash) to allow condensate water (if any) in the Housing to drain.
 - Humidifier is energized when the Inducer and the Heat Speed are energized. ("ON" after Heat On Delay - "OFF" after Post Purge).
 - Humidifier is energized with the Inducer Only. ("ON" with call for heat - "OFF" after Post Purge.)
 - Time delay to OFF is controlled by the ICM-2 motor control board, DIP switches number 5 and 6.
 - Prior to E-4 - N/A, E4 and later is 30 seconds.
 - Ignition warm up - 20 seconds, retry 20 seconds. (Varies voltage on ignitor by 2% reduction on successful cycles) If cycle fails, then retry, 6% increase. If lockout or power loss, the count starts over.
- ⑩ **Diagnostic Indicator Flash Codes:**
- | | |
|------------------------------------------------------------|------------------------------------------------|
| 2 Flashes - System Lockout (Retries or Recycles Exceeded). | 7 Flashes - Gas Valve Circuit Error. |
| 3 Flashes - Pressure Switch Stuck Open or Closed. | 8 Flashes - Low Flame Sense Signal. |
| 4 Flashes - Open High Temperature Limit Switch. | Slow Flash - Normal, No Call For Heat Present. |
| 5 Flashes - Flame Sensed Without Gas Valve. | Fast Flash - Normal, Call For Heat Present. |
| 6 Flashes - 115 Volt AC Power Reversed. | Continuous On - Internal Control Failure. |

White-Rodgers 50A50/50A51 Fault Diagnostics

System Lockout (Loss Of Flame)

When the Control fails to detect a flame current signal during the trial for ignition period,^① the gas valve and ignitor will be de-energized and the retry sequence initiated. During the retry sequence, the induced draft motor will be energized for an interpurge period.^① The ignition sequence will be restarted with an additional period^① of ignitor warm-up time following the interpurge period. The Control will retry the ignition sequence 2 consecutive times (3 total) before system lockout.

IMPORTANT

IGNITION CONTROL IS POLARITY SENSITIVE. HOT LEG OF 120 VOLT POWER SUPPLY MUST BE CONNECTED TO THE BLACK LINE POWER LEAD AS INDICATED ON WIRING DIAGRAM OR IGNITION LOCKOUT WILL OCCUR.

The initial ignition sequence will be recycled, or repeated, if the flame is sensed and then lost after 10 seconds. The Control retry counter will be reset if the flame is sustained for longer than 10 seconds during an ignition recycle attempt. The system will lockout if the flame is not sustained after the 4th or 10th^① ignition recycle attempt.

A momentary loss of gas supply, flame blowout, or a shorted or open flame sensor will be sensed within 0.7 seconds during a normal heating cycle. The Control will then de-energize the gas valve and recycle the ignition sequence. As long as the call for heat still exists, a normal heating operation will resume if the gas supply returns or the fault condition is corrected before the 4th or 10th^① ignition recycle. Otherwise, the Control will go into system lockout.

When a system lockout occurs, the Control de-energizes the gas valve, energizes the induced draft motor (low speed on 50A51 Controls) and energizes the indoor blower on heat speed. The diagnostic LED will begin flashing 2 times to indicate a system lockout due to loss of flame.

If a momentary (50 milliseconds, or longer) loss of system power occurs during a normal heating cycle, the gas valve will be de-energized. When the power is restored, the gas valve will remain de-energized and the ignition sequence restarted as long as the call for heat still exists.

When the Control has gone into system lockout due to loss of flame, the Control must reset before the system will restart the heating operation. The Control may be manually reset by setting the thermostat system switch to OFF and then ON again within 1 to 21 seconds or by interrupting system power to the Control for longer than 1 second.

The 50A50 and 50A51 Series Controls automatically reset a system lockout condition after one or two hours.^①

Pressure Switch Problem

Single-Stage Systems

When a call for heat is received and the pressure switch contacts are sensed closed before the induced draft motor is energized, the Control will delay energizing the induced draft motor, stop the ignition sequence and begin flashing the diagnostic LED 3 times to indicate a pressure switch problem. When the pressure switch contacts open, a normal ignition sequence will begin after the contacts close again and the 3 flash fault will return to steady fast flash to indicate a normal call for heat.

When a call for heat is received and the pressure switch contacts are sensed open after the induced draft motor is energized, the Control will not allow the gas valve to open. The ignition sequence will be stopped and the diagnostic LED begins flashing 3 times to indicate a pressure switch problem. If this occurs, the problem may be induced draft motor failure or excessive pressure against the blower outlet and not allowing the pressure switch contacts to close. When the pressure switch contacts close, a normal ignition sequence will begin and the 3 flash fault will return to a steady fast flash to indicate a normal call for heat.

If the control senses the pressure switch contacts are open during a normal heating cycle, the gas valve will be de-energized to remove the flame and the system shutdown sequence initiated, induced draft motor will continue to run. This problem may also be due to induced draft motor failure or high wind. The Control will begin flashing the diagnostic LED 3 times to indicate a pressure switch problem. When the pressure switch contacts close, a normal ignition sequence will begin and the 3 flash fault will return to a steady fast flash to indicate a normal call for heat.

^① See Integrated Furnace Control Label or Timing Chart.

White-Rodgers 50A50/50A51 Fault Diagnostics

50A50-405/406 Prior To Revision E4

If the condensate drain is blocked on condensing (90%) furnace models, either by debris, improper draining, or by freezing condensate, the pressure switch contacts will open. When the Control senses the pressure switch contacts are open, the gas valve will be de-energized to remove the flame and the system shutdown sequence initiated. The Control will begin flashing the diagnostic LED 3 times to indicate a pressure switch problem. The system will remain shutdown until the condensate drain has been cleared and the condensate flows freely. When the pressure switch contacts close, a normal ignition sequence will begin and the 3 flash fault will return to a steady fast flash to indicate a normal call for heat.

During a normal heating cycle, if the 50A50-405/406 Rev. E4-E6/471/472/473/474/571 Control senses the pressure switch contacts are closed and then open the gas valve will be de-energized to remove the flame, if the pressure switch does not reclose in 60 seconds the induced draft motor will be de-energized for 30 seconds. After the 30 second delay, a normal ignition sequence will begin. On condensing (90%) models, the delay allows any condensate, that may be blocking the pressure switch sensing tube, time to drain. On 80% models, the delay provides another attempt for the induced draft motor to reach maximum speed and close the pressure switch contacts.

Pressure Switch Problem

50A51-405 Two Stage and 50A51-505 Two Stage Variable-Speed Systems

On systems using 50A51-405 two-stage and 50A51-505 two-stage variable-speed Controls, the first stage pressure switch fault diagnostic operation is the same as the 50A50-405/-406 Controls. (Prior to Revision E4.)

During a normal 1st stage heating cycle, when the thermostat calls for 2nd stage heat, there will be a 30 second delay between 1st and 2nd stage heat. If the thermostat calls for 1st and 2nd stage heat at the same time, there will be a 10 minute delay between 1st and 2nd stage heat.

During the 1st stage ignition sequence, the induced draft motor will always be energized to high speed. When the Control senses the 1st stage pressure switch closed, the induced draft motor is energized to low speed.

If the 1st stage pressure switch closes and then opens during the ignitor warm-up period, the Control will begin flashing the diagnostic LED 3 times to indicate a pressure switch problem and wait 10 seconds for the pressure switch contacts to close. If the 1st stage pressure switch contacts close, a normal ignition sequence will resume and the 3 flash fault will return to a steady fast flash to indicate a normal call for heat.

If the 1st stage pressure switch contacts do not close in 10 seconds, the induced draft motor is energized to high speed in an attempt to close the contacts. When the contacts close, a normal ignition sequence will resume and the induced draft motor will remain energized on high speed until the flame is sensed for a minimum of 10 seconds. The induced draft motor will then be energized to low speed and the 3 flash fault will return to steady fast flash to indicate a normal call for heat. If the 1st stage pressure switch contacts do not remain closed and the ignition sequence has been recycled for the 4th time, the Control will go into system lockout and begin flashing the diagnostic LED 2 times to indicate a system lockout due to loss of flame.

During a 2nd stage call for heat, if the 2nd stage pressure switch contacts do not close within the 30 second delay between stages, the Control will de-energize the gas valve to remove the flame and begin flashing the diagnostic LED 3 times to indicate a pressure switch problem. After the Control senses the loss of flame, a 3 minute error timer will be started and the shutdown sequence initiated as if the call for heat were removed. The induced draft motor will remain energized on high speed for a 5 second postpurge and the (selected) indoor blower "off" delay timer will begin.

After the 3 minute error time delay, the Control will restart the heating cycle if the thermostat is still calling for 1st and 2nd stage heat. If the 2nd stage pressure switch contacts still have not closed after the 10 minute delay between stages, the Control will repeat the above shutdown sequence as long as the thermostat calls for 2nd stage heat.

① See Integrated Furnace Control Label or Timing Chart.

White-Rodgers 50A50/50A51 Fault Diagnostics

Pressure Switch Problem

50A51-495/-506/-507 Two Stage Variable-Speed Systems

The induced draft motor will always be energized to high speed. The induced draft motor will be energized to low speed when the Control senses the 1st stage pressure switch contacts have closed.

If the 1st stage pressure switch contacts open during a normal 1st stage heating cycle, the gas valve will be de-energized to remove the flame and the induced draft motor will be energized to high speed for 10 minutes. If the 1st stage pressure switch contacts close during the 10 minute high speed purge, the Control will restart the ignition sequence. If the 1st stage pressure switch contacts remain closed after 10 minutes, the induced draft motor will be energized to low speed and a normal heating operation will continue. If the pressure switch contacts do not close after 10 minutes, the induced draft motor will be energized again to high speed for 10 minutes and the diagnostic LED will begin flashing 3 times to indicate a pressure switch problem. Recycling the induced draft motor will continue as long as a 1st stage call for heat exists and the Control will not go into lockout.

The 2nd stage pressure switch fault diagnostic operation is the same as 50A51-405/-505 Controls.

Thermal Protection Devices

At any time during a call for heat, if the Control senses the high temperature limit (and/or aux. limit) or flame roll out switch(es) are open, the gas valve is de-energized, the induced draft motor is energized (low speed on 50A51 Controls), and the indoor blower is energized to run on heat speed.

On models utilizing fusible link devices, the fusible link is a single use device and must be replaced if it has opened. However, if the temperature the fusible link senses is approaching the trip temperature but does not exceed it, the contacts may open and close intermittently. The Control will initiate another ignition sequence upon the closure of the intermittent fusible link.

Flame Sensed With Gas Valve Off

At any time the Control senses a flame current signal without a call for heat or when the gas valve is de-energized, the induced draft motor is energized (low speed on 50A51 Controls), and the indoor blower is energized to run on heat speed.① The Control will go into system lockout and will not reset until this fault is corrected. The diagnostic LED will begin flashing 5 times to indicate the flame sensed with the gas valve de-energized.

① See Integrated Furnace Control Label or Timing Chart.

White-Rodgers 50A55-571/-474 Self Diagnostic Features

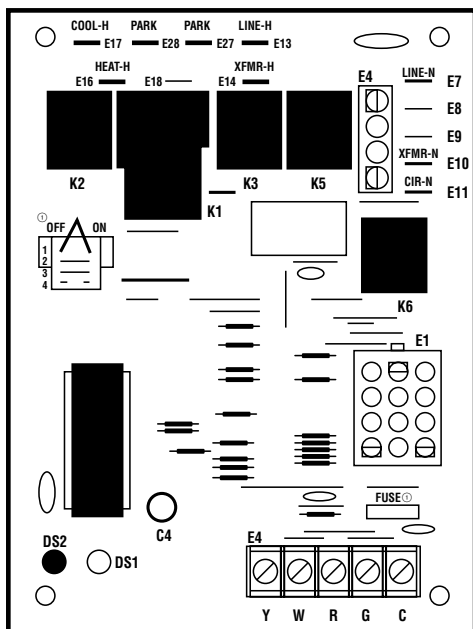

CNT2789

Slow Flash – Normal, No Call For Heat Present.

Fast Flash – Normal, Call For Heat Present.

Continuous On – Internal Control Failure.

Diagnostic Indicator Flash Codes:

- 2 Flashes – System Lockout (Retries or Recycles Exceeded).
- 3 Flashes – Pressure Switch Stuck Open or Closed.
- 4 Flashes – Open High Temperature Limit Switch.
- 5 Flashes – Flame Sensed Without Gas Valve.
- 6 Flashes – 115 Volt AC Power Reversed.
- 7 Flashes – Gas Valve Circuit Error.
- 8 Flashes – Low Flame Sense Signal.

See Pages 14 and 15 for Sequence of Operation and Wire Schematic.

① Fuse only on 474 Model and Dip Switches replace jumpers.

Single Stage 50A50 and 50A55 Sequence of Operation

White-Rodgers Integrated Furnace Controls 50A50-405/-406/-471/-472/-473/-474/-571 and 50A55-571/-474 Models

When the disconnect ① is in the "ON" position, power is applied through the blower door interlock switch ⑥ to the control line voltage input terminal ⑧ and out of the control to the primary side of the control transformer "XFMR" ⑨. The low voltage side of the transformer supplies 24 volts to the control through terminals "TH" ⑩ and "TR" ⑪. Control terminal "R" ⑫ supplies 24 volts to the "R" terminal of the room thermostat.

Once power is applied, the control flashes the LED "ON" for 1 second and performs a self check routine. Following the normal system check, the control flashes the LED light once per second continuously (slow flash) while in stand-by.

On a call for heat, 24 volts is applied from the thermostat terminal "W" to the "W" terminal ⑬ on the control. The control checks and confirms normally closed contacts at the temperature cut out "TCO" ⑭, the auxiliary limit (downflow and some upflow/horizontal models), the flame roll-out fuse link (two fuse links are used on downflow and upflow/horizontal models) ⑮ and ⑯ and normally open contacts of the safety pressure switch "PS" ⑰. With all safety and control switches in their proper position, the control will energize the induced draft motor ⑱ and flash the LED light two times per second continuously (fast flash) during a call for heat.

When the safety pressure switch "PS" ⑰ closes, the control begins the ignition sequence. The hot surface ignitor ⑲ is energized for several seconds (see note) allowing the thermal element to heat up. The control then switches on 24 volts to the gas valve "MV" termi-

nals #1 ⑳. The redundant and main solenoids are energized allowing gas flow and main burner ignition. When flame current is detected by the control through its terminal "FP" ㉑, the 45 second indoor blower motor delay on timing begins. Flame failure response time is set for 2 seconds. After flame has been established for ten seconds, the flame failure response time is reset for 0.7 seconds. If flame current is not sensed by the control ㉒ within the trial for ignition period (see note), the redundant and main gas valve solenoids ㉓ are de-energized. The control will begin a interpurge cycle and adds additional seconds to the hot surface ignitor warm-up timing (see note). The control energizes the gas valve ㉔ for the second attempt to establish main burner ignition. If flame current is not sensed by the control on the 2nd retry within the trial for ignition period (see note), the control will repeat the previous cycle one additional time before locking out.

At the end of the indoor blower delay on time, line voltage is applied at the controls terminal "HEAT" ㉕ energizing the indoor blower motor at heating fan speed, supplying warm air to the space.

When the thermostat is satisfied, the gas valve's redundant and main solenoids ㉓ are de-energized, extinguishing main burner flame. Once the control senses loss of flame current (0.7 sec.) ㉖, the induced draft motor ⑱ is de-energized after a five second post purge cycle. The indoor blower motor delay off timing begins. At the completion of the fan delay off timing, the indoor blower motor ㉗ is de-energized and the cycle is complete.

Note: See Timing Chart for details or Integrated Furnace Control Label.

Wiring Schematic

Single Stage (White-Rodger's 50A50 and 50A55 Series Integrated Furnace Controls)

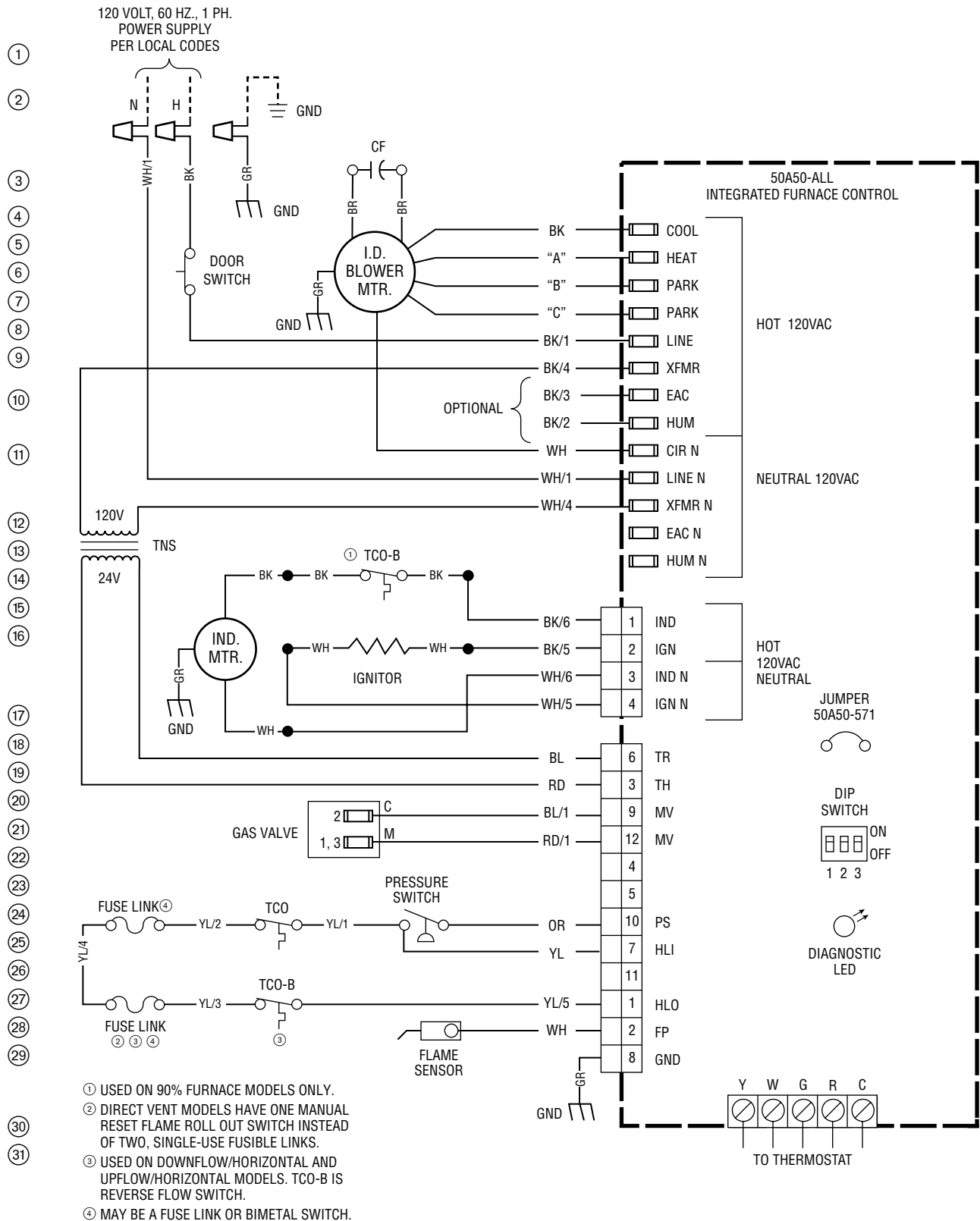

Note: See Integrated Furnace Control on Timing Chart for Control Details.

Two Stage 50A51 Sequence of Operation

White-Rodgers Integrated Furnace Control 50A51-405/-495 Models

When the service disconnect ① is in the "ON" position, power is applied through the blower door interlock switch ⑥ to the controls line voltage input terminals ⑧ and out of the control to the primary side of the control transformer "XFMR" ⑰. The secondary side of the control transformer supplies 24 volts to the control through terminal "TH" and "TR" ⑳⑱. Control terminal "R" ⑳ supplies 24 volts to the "R" terminal of the room thermostat.

Once power is applied, the control flashes the LED light "ON" for one second and performs a self check routine. Following the normal system check, the control flashes the LED one time per second (slow flash) continuously while in stand-by.

On a call for heat, 24 volts is applied from the room thermostats "W1" terminal to the "W1" terminal ⑳ on the control. The control checks and confirms normally closed contacts at the temperature cut out "TCO" ㉓, auxiliary limit (downflow and some upflow/horizontal models), the flame roll-out fuse link (two fuse links are used on downflow and upflow/horizontal models) ㉔ and normally open contacts at the safety pressure switch #1 ㉓. With all safety and control switches in their proper position, the control will energize the induced draft motor on high speed ㉔ and flashes the LED two times per second continuously (fast flash) during a call for heat.

When safety pressure switch "#1" ㉓ closes, the control switches the induced draft motor to low speed ㉔ and begins the ignition sequence. The hot surface ignitor ㉔ is energized for several seconds (see note) allowing the thermal element to heat up. The control then switches 24 volts to its "MVL" and "MV COM" ㉔ terminals to terminals #1 ㉔ and #2 ㉔ on the gas valve. The redundant and main solenoids are energized allowing gas flow and main burner ignition. When flame current is sensed by the control through its "FP" ㉔ terminal, the 45 second indoor blower motor time delay "ON" begins. Flame failure response time is set for 2 seconds. After flame has been established for 10 seconds, the flame failure response time is reset for 0.7 seconds. If flamed current is not sensed by the control within the trial for ignition period (see note),

the main valve low and redundant gas valve solenoids ㉔, ㉔ are de-energized. The control will begin a interpurge cycle and adds additional seconds to the hot surface ignitor warm-up timing (see note). The control energizes the gas valve for the second attempt to establish main burner ignition. If again flame current is not sensed by the control within the trial for ignition period (see note), the control will repeat the previous cycle before locking out. At the end of the indoor blower motor delay "ON" timing, line voltage is applied at control terminal "HEAT LO" ⑥ energizing the indoor blower motor at low heat fan speed, supplying warm air to the space.

If the temperature in the space continues to fall, the thermostat second stage contacts "W2" close. 24 volts is switched from thermostat terminal "W2" to the "W2" terminal ㉔ on the control. A 30 second, 2nd stage recognition time delay begins. At the end of the 30 second delay, the induced draft motor is switched to high speed ㉔ causing pressure switch #2 ㉔ to close. When pressure switch #2 closes, 24 volts is switched from control terminal "MVH" ㉔ to the gas valve terminal #3 ㉔ energizing the second stage solenoid allowing increased gas flow to the burners. At the same time, the indoor blower motor is switched to high heat fan speed ㉔.

When second stage thermostat contacts "W2" satisfy, the induced draft motor is switched back to low speed ㉔ causing pressure switch #2 ㉔ to open breaking the circuit to the second stage gas valve solenoid ㉔. Gas flow is reduced to the burners. The indoor blower motor will switch back to low heat fan speed after a 30 second delay ⑥.

When first stage thermostat contacts "W1" satisfy, the main valve low and the redundant gas valve solenoids ㉔ are de-energized extinguishing main burner flame. Once the control senses the loss of flame current (0.7 sec.) ㉔, the induced draft motor ㉔ is de-energized after a five second post-purge cycle. The indoor blower motor "OFF" timing begins. At the end of the indoor blower motor "OFF" timing, the indoor blower motor is de-energized and the cycle is complete.

Note: See Timing Chart for details or Integrated Furnace Control Label.

Wiring Schematic

Two Stage Heat (White-Rodgers 50A51 Series Integrated Furnace Control)

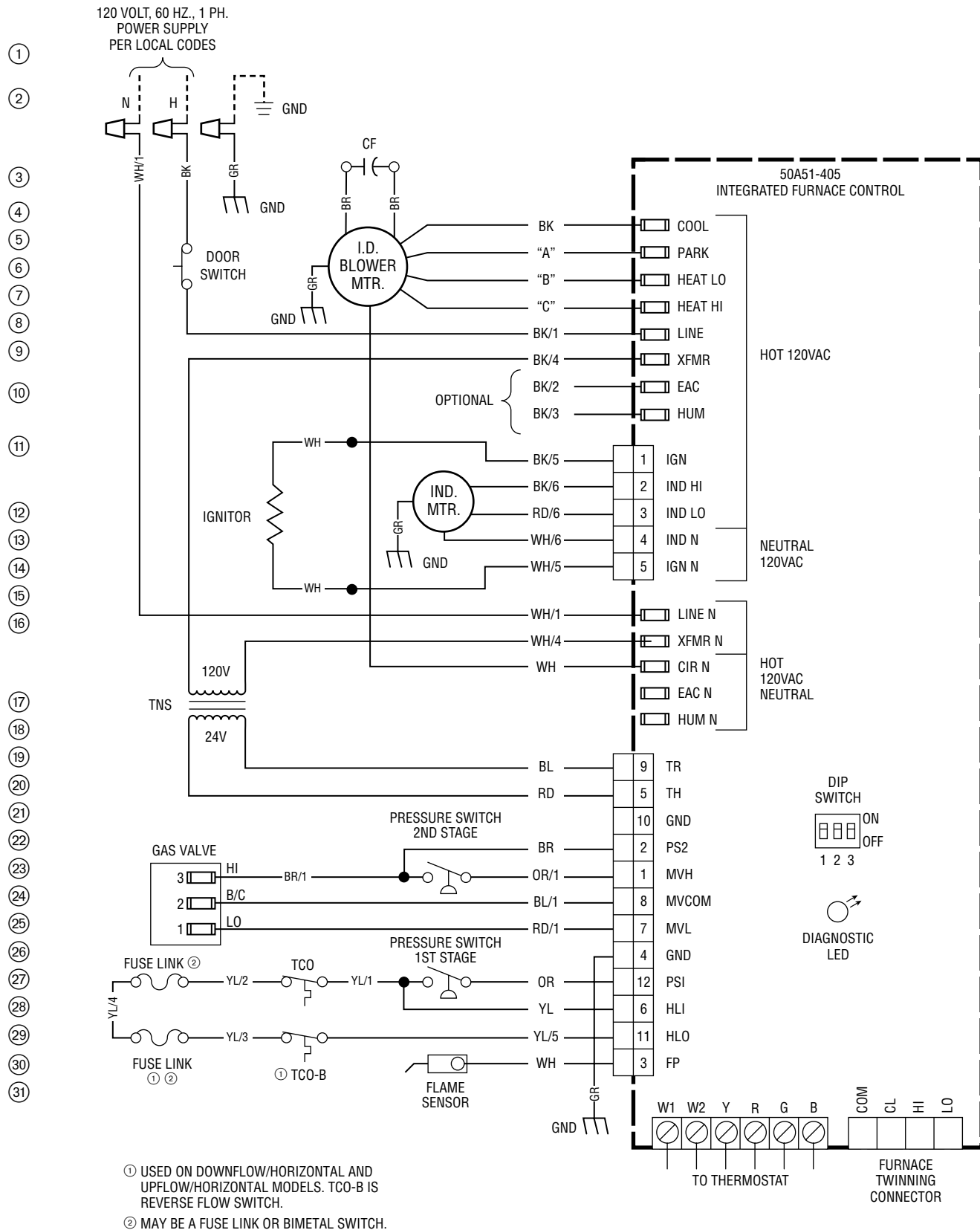

Note: See Integrated Furnace Control on Timing Chart for Control Details.

Two Stage Variable Speed Sequence of Operation

White-Rodgers Integrated Furnace Controls 50A51-505/-506/-507 and 50A61-605 Models

When the service disconnect ① is in the "ON" position, power is applied through the blower door interlock switch ③ to the controls line voltage input terminals ⑥ and out of the control to the primary side of the control transformer ⑨, and from the "CIRC" ⑦ terminal to the ECM™ Fan Motor ③. The secondary side of the control transformer supplies 24 volts to the control through terminal "TH" and "TR" ⑫, ⑬. Control terminal "R" ⑮ supplies 24 volts to the "R" terminal of the room thermostat.

Once power is applied, the control flashes the LED light "ON" for one second and performs a self check routine. Following the normal system check, the control flashes the LED one time per second (slow flash) continuously while in stand-by.

On a call for heat, 24 volts is applied from the room thermostats "W1" terminal to the "W1" terminal ⑮ on the control. The control checks and confirms normally closed contacts at the temperature cut out "TCO" ⑳, auxiliary limit (downflow and some upflow/horizontal models), the flame roll-out fuse link (two fuse links are used on downflow and some upflow/horizontal models) ㉑ and normally open contacts at the safety pressure switch #1 ㉒. With all safety and control switches in their proper position, the control will energize the induced draft motor on high speed ⑨ and flashes the LED two times per second continuously (fast flash) during a call for heat.

When safety pressure switch "#1" ㉒ closes, the control switches the induced draft motor to low speed ⑩ and begins the ignition sequence. The hot surface ignitor ⑨ is energized for several seconds allowing the thermal element to heat up. The control then switches 24 volts to its "MVL" ⑰ and "MV COM" ⑱ terminals to terminals #1 ⑰ and #2 ⑱ on the gas valve. The redundant and main solenoids are energized allowing gas flow and main burner ignition. When flame current is sensed by the control through its "FP" ㉔ terminal, the 45 second indoor blower motor time delay "ON" begins. Flame failure response time is set for 2 seconds. After flame has been established for 10 seconds, the flame failure response time is reset for 0.7 seconds. If flamed current is not sensed by the control ㉔ within the trial for ignition period, the main valve low and redundant gas valve solenoids ⑰ are de-energized. The control will begin a 30 second interpurge cycle and adds additional

seconds (see note) to the hot surface ignitor warm-up timing. The control energizes the gas valve for the second attempt to establish main burner ignition. If again flame current is not sensed by the control within the trial for ignition period (see note), the control will repeat the previous cycle before locking out. At the end of the indoor blower motor delay "ON" timing, the microprocessor will close the normally open **K3** relay contacts ㉗ completing a 24 volt signal circuit to pin #15 of the ECM™ motor, signaling it to turn on and run at the low heat blower speed, supplying warm air to the space. 24 volts W1 ⑮ terminal from the thermostat is also applied to the ECM™ motor harness pin #12㉘, which signals the ECM™ motor to run at the low heat speed setting.

If the temperature in the space continues to fall, the thermostat second stage contacts "W2" close. 24 volts is switched from thermostat terminal "W2" to the "W2" terminal ⑮ on the control. A 30 second, 2nd stage recognition time delay begins. At the end of the 30 second delay, the induced draft motor is switched to high speed ⑨ causing pressure switch #2 ⑲ to close. When pressure switch #2 closes, 24 volts is switched from control terminal "MVH" ⑲ to the gas valve terminal #3 ⑲ energizing the second stage solenoid allowing increased gas flow to the burners. At the same time, the microprocessor closes the normally open **K1** relay contacts ㉗ completing a 24 volt signal circuit to pin #13 ㉚ of the ECM™2 motor signaling the indoor blower motor to run at the high heat blower speed.

When second stage thermostat contacts "W2" satisfy, the induced draft motor is switched back to low speed ⑩ causing pressure switch #2 ⑲ to open breaking the circuit to the second stage gas valve solenoid ⑰. Gas flow is reduced to the burners. The indoor ECM™ blower motor ④ will be switched back to the low heat fan speed after a 30 second delay.

When first stage thermostat contacts "W1" satisfy, the main valve low and the redundant gas valve solenoids ⑰ are de-energized extinguishing main burner flame. Once the control senses the loss of flame current (0.7 sec.)㉔, the induced draft motor ⑨ is de-energized after a five second post-purge cycle. The indoor blower motor "OFF" timing begins. At the end of the indoor blower motor "OFF" timing, the indoor blower motor is de-energized and the cycle is complete.

Note: See Timing Chart for details or Integrated Furnace Control Label.

Wiring Schematic

Two Stage Variable Speed (White-Rodgers 50A51 and 50A61 Series Integrated Furnace Controls)

①

②

③

④

⑤

⑥

⑦

⑧

⑨

⑩

⑪

⑫

⑬

⑭

⑮

⑯

⑰

⑱

⑳

㉑

㉒

㉓

㉔

㉕

㉖

㉗

㉘

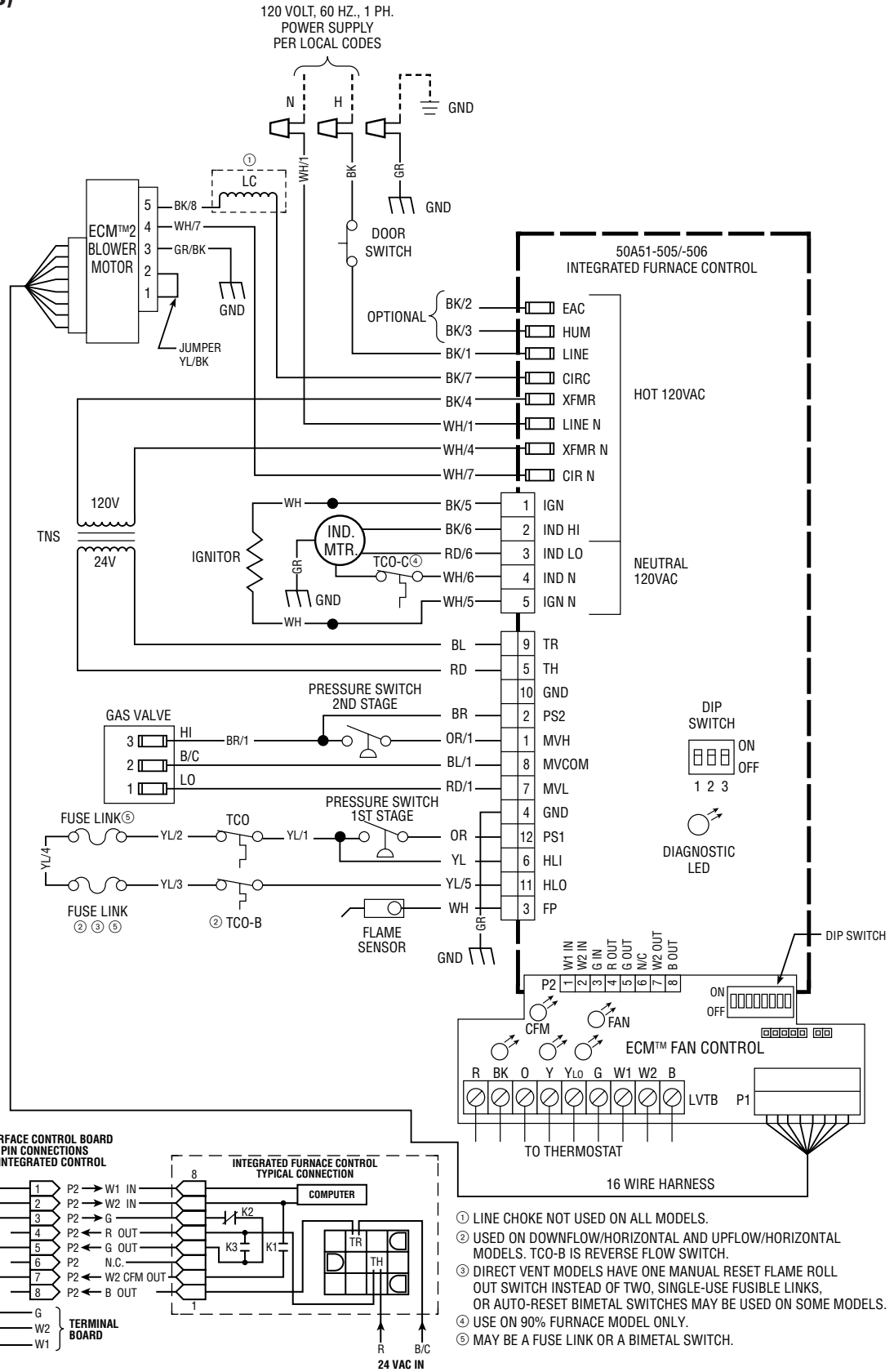

- ① LINE CHOKE NOT USED ON ALL MODELS.
- ② USED ON DOWNFLOW/HORIZONTAL AND UPFLOW/HORIZONTAL MODELS. TCO-B IS REVERSE FLOW SWITCH.
- ③ DIRECT VENT MODELS HAVE ONE MANUAL RESET FLAME ROLL OUT SWITCH INSTEAD OF TWO, SINGLE-USE FUSIBLE LINKS, OR AUTO-RESET BIMETAL SWITCHES MAY BE USED ON SOME MODELS.
- ④ USE ON 90% FURNACE MODEL ONLY.
- ⑤ MAY BE A FUSE LINK OR A BIMETAL SWITCH.

Integrated Control Quick Reference

Service Tips

To the qualified service man, these controls are very simple and easy to work on. A list of required service tools needed to work on any solid state ignition control today are listed below:

A reliable Volt/OHM Multimeter (preferably a digital with a microamp scale on it). The Microamp Meter is used to measure flame current.

A U-Tube Water Manometer (or pressure gauge) to test inlet and out gas valve pressure.

An Incline Manometer with a 0-2" water column scale to test pressure switches and ductwork static pressure.

1. When the thermostat fan switch is placed in the "ON" position, the fan will run at heating fan speed. Low heat fan on two stage 50A51 series controls.

2. In order to obtain cooling air flow, the thermostat "Y" terminal must be connected to the "Y" terminal on the control. **If the "Y" is not connected, low heat speed will be activated during a cooling cycle.**

3. If a single stage heat thermostat is used with the 50A51 two stage control, there will be a **10 minute delay** between first and second stage heat if W1 and W2 are jumpered.

4. The control requires **one microamp DC minimum flame current** in order to maintain a call for heat.

5. The control will add seconds to the igniter heat-up period on second and third trial for ignition with interpurge between trials. See Integrated Furnace Control label or Timing Chart for details.

6. Once flame current has been established by the control for 10 seconds, the retry counter in the control is reset to zero.

7. If flame current is interrupted, the control will break current flow to the gas valve and immediately begin a recycle for ignition without a purge cycle or increase in igniter warm-up time. If flame current is interrupted during 2nd stage operation, the recycle sequence is initiated and Hi fire or 2nd stage will resume immediately.

8. If a lockout occurs, the control automatically resets the trial for ignition sequence every one or two hours provided a call for heat continues to exist. See Timing Chart , Reset Time Column, for details.

9. To reset control after lockout:

- a. Interrupt line voltage power to the control for a minimum of 1 second.
- b. Turn thermostat system switch off and back on twice within 30 seconds.

10. Voltage input range:

Line 97-132 VAC 50/60HZ – Nominal 120 volts AC

Control 20-30 VAC 50/60HZ – Nominal 24 volts AC

11. 50A50 controls with date codes prior to 9348 require an isolation relay in the "Y" circuit when used with Add On Heat Pump Plus One kits, to prevent cold air complaints during defrost. The control would not allow a cooling (Y) and heating (W) output at the same time so the control would de-energize the "W" circuit and there would be no supplement heat during defrost cycles.

12. The humidifier accessory lead is energized whenever there is a heating call and the fan is operating. See IFC Timing Chart for details, page10.

13. The electronic air cleaner accessory lead is energized whenever there is a 24 volt signal on G or Y or during a heating call when the indoor fan is operating.

A detailed troubleshooting chart for each model of the integrated furnace control is included in this manual to help the service technician work through abnormal conditions with these controls.

The troubleshooting section with fault charts for all White-Rodgers controls are located on pages 48 through 62. See page 48 for procedures and chart references.

Furnace ECM™2 Motor Operation

A Call on “Y” and “G” together. The indoor blower will run at 100% and the red “Y” LED will be on, “YLO” LED if two speed outdoor unit.

“O” is the ramp, or time delay and humidistat enable input. This “O” input must be received by the ECM™2 Motor Computer for these cycles to operate. Cooling only units jumper “Y” to “O” at the low voltage Motor Control board.

Ramped Operation, Dip Switch No. 5 and No. 6 ON, will work in the cooling cycle only. A call on the “Y”, “G” and “O” together must be present for a ramped ON and OFF cycle. If the “O” does not receive 24 volts AC the 7 1/2 minute run period at 80% of full airflow will not occur.

Cooling Humidistat Operation – “BK” and “R” terminals are connected to the humidistat. When the indoor humidity is high, the humidistat’s switch will be open and the blower air flow will be reduced 20%. The red “BK” LED will be off when the humidistat is open. If a humidistat for cooling is not used, “BK” terminal must be jumpered to “R” terminal. If not, only 80% of the cooling airflow will be delivered. The red “BK” LED will be on when the humidistat is closed.

Air Flow Priority – is “W1” or “W2”, not the highest airflow of “Y” or “W1” or “W2”. A Dual Fuel installation, a furnace and a heat pump, the airflow is compressor “Y” airflow except during the defrost cycle. Then the blower will run at W1 airflow when the furnace is on.

Cooling Cycle – Blower Time Delay to off is controlled by the ECM™2 Motor and Dip Switch No. 5 and No. 6 on the Motor Control Board. The White-Rodgers Ignition Control Dip Switch #1 must be set for 0 seconds turned on when a ramped or time-delay cycle is selected.

Heat Exchanger Cool-Down Cycle – The airflow will go to 50% of the cooling air flow. Heating cool down time is controlled by the White Rodgers Ignition Control, Dip Switches No. 2 and No. 3.

Fan Continuous Operation – The airflow is 50% of the cooling airflow. If cooling airflow is required for continuous operation, remove field installed wires from “Y” terminal on the low voltage terminal board and wire nut them together. Then connect “G” terminal to “Y” terminal with a jumper.

Green CFM LED – Will flash one time for each 100 CFM selected. Half flash for each 50 CFM selected.

DIP Switch Settings (ECM™ Fan Control)

- 1, 2 – Tonnage of Outdoor Unit
- 3, 4 – CFM Ton
- 5, 6 – Ramped/Enhanced
- 7, 8 – Heating Air Flow

DIP Switch Settings (Integrated Furnace Control)

- 1 – Always On
- 2, 3 – Heat Blower Off Delay, see IFC Timing Chart for Details, page 10)

Ramped Operation

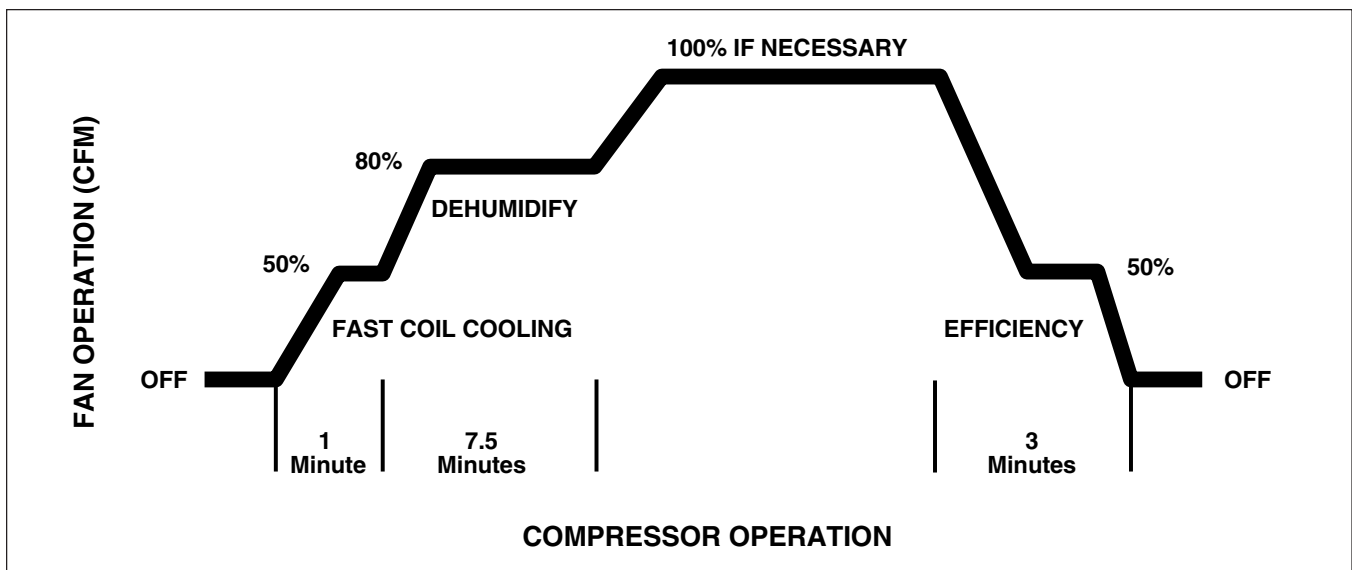

Cooling Only

ECM™2 Variable Speed Furnace Motor Quick Check

Blower Motor Will Not Run

1. Jumper 24 Volt A.C. "R" terminal to "G" terminal on the Motor Control Board.

Does motor run?

No: Go to step number 2.

Yes: Motor runs, check thermostat and thermostat wire.

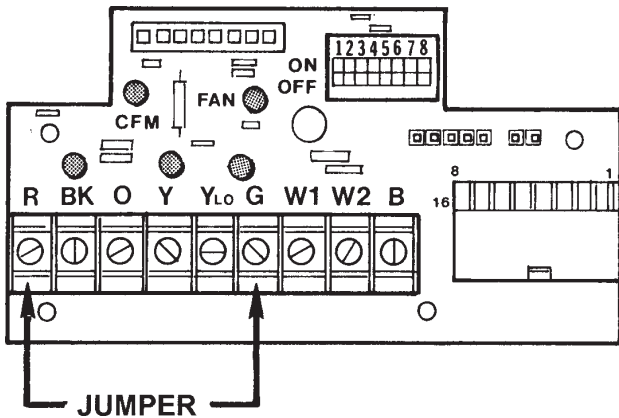

2. Unplug 16 wire low voltage harness from the motor control board. Jumper 24 Volts A.C. to pins 12, 15 and common pins 1 and 3.

Does the motor run?

No: Go to step number 3.

Yes: Go to step number 5.

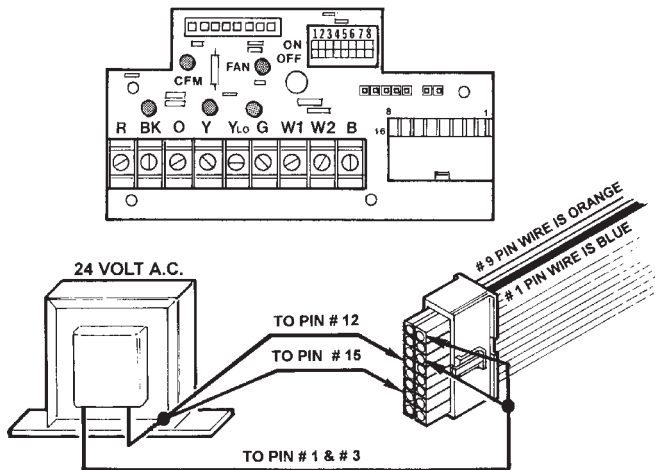

3. Unplug 16 wire low voltage harness from the motor. Jumper 24 Volts A.C. to motor low voltage plug pins number 12 and number 15 and pins number 1 and number 3 which are common.

Note: Test plug can be made from a good harness to simplify this check.

Does motor run?

No: Go to step number 4.

Yes: Fault is in the 16 wire low voltage harness. Repair or replace it.

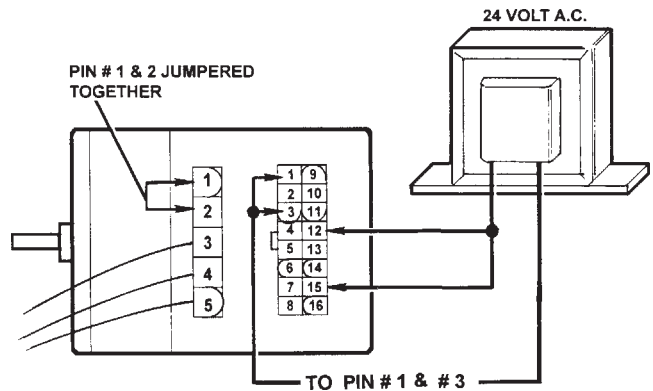

4. Is the line voltage to the motor high voltage power plug pin 4 and pin 5 correct?

Furnace ECM™2 motor correct voltage is 120 Volts A.C. and there must be a jumper wire in this plug between pins 1 and 2.

No: Correct line voltage fault.

Yes: Line voltage correct and motor will not run. Replace motor.

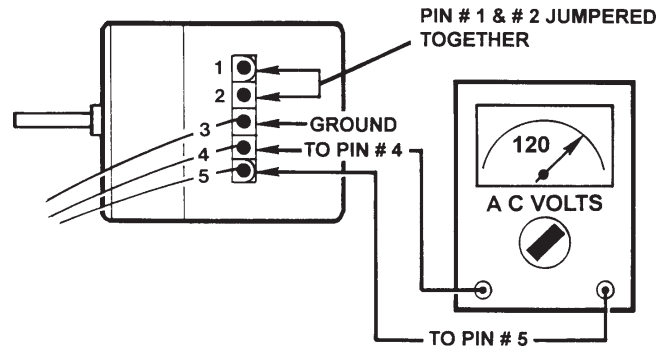

ECM™ 2 Variable Speed Furnace Motor Quick Check

5. Plug the 16 wire low voltage harness from the motor back into the motor control board. Jumper "G IN" pin to "G OUT" pin of the White-Rodgers Integrated Control which plugs into the low voltage motor control board.

Does the motor run?

Yes: Replace White-Rodgers Integrated Control.

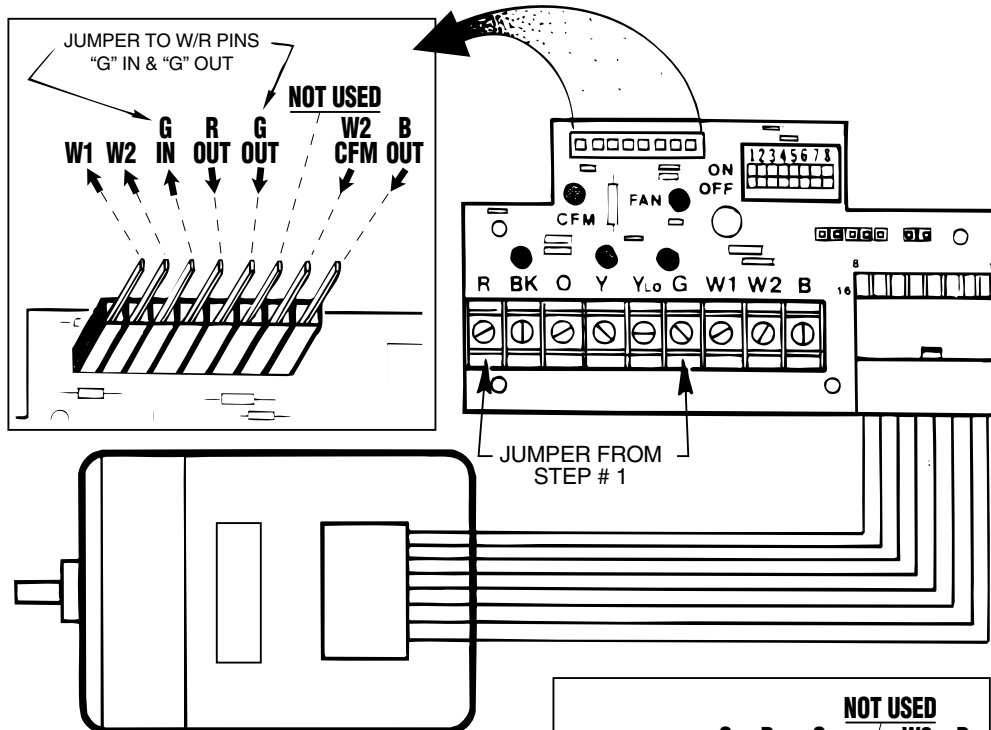

No: Move the jumper to the metal part of the low voltage motor control board plug.

Does the motor run?

Yes: White-Rodgers Integrated Control pins not making contact with motor control board plugs. Clean pins and plug by unplugging and plugging motor control board onto the pins of the integrated control or replace both if necessary.

No: Repair or replace the motor control board.

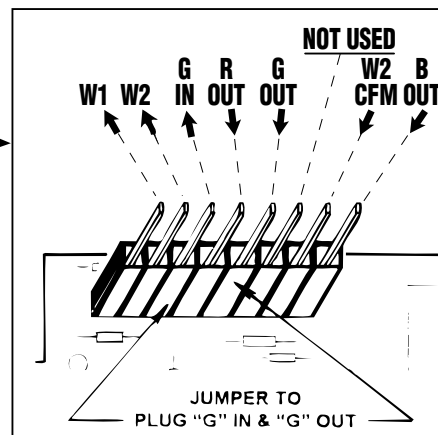

Furnace Motor Control Board Schematic – CNT1537

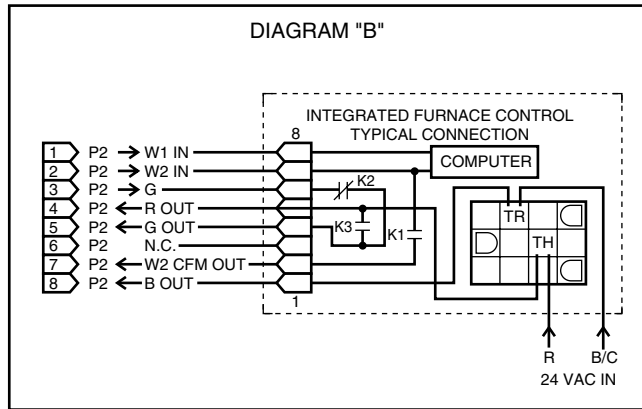
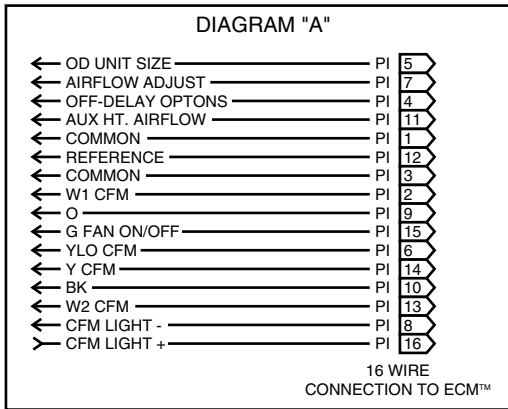
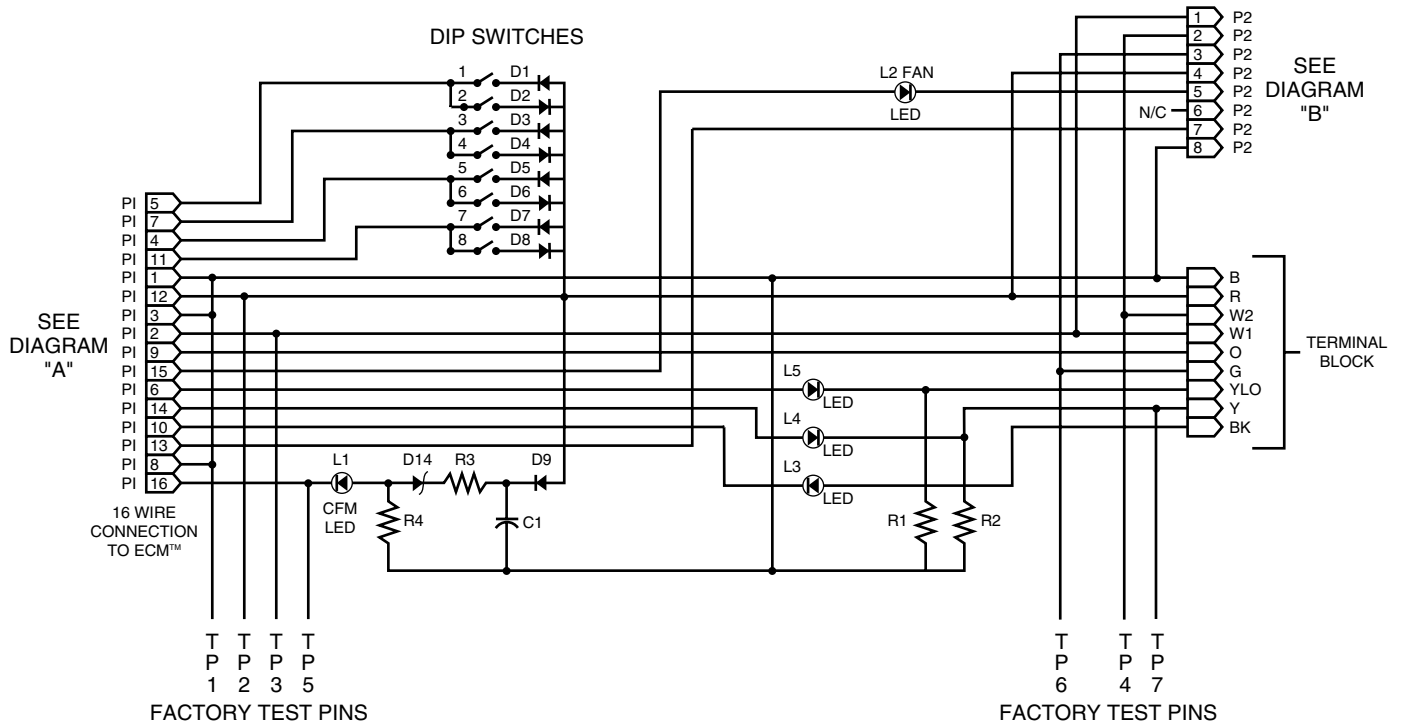

Flame Rectification Principle – Measurement

The White-Rodgers 50A50 and 50A51 integrated controls use the flame rectification principle to prove that flame is present after the gas valve has been energized.

The flame rectification principle is based on the fact that a flame can conduct electrical current. When a positive charge is placed on the flame sensor and a flame is present to complete the circuit from the burner surface or ground, current will flow from the burner ground (zero potential) through the flame to the flame sensor which has a greater positive charge.

The ignition control will sense the current flow and allow the gas valve to remain open and the heating cycle to continue. The flame current is monitored by the ignition control and will shut down the gas valve if the minimum flame sense current is not present for more than 0.7 seconds.

The 50A50 and 50A51 White-Rodgers integrated furnace controls require a minimum of 1.0 micro amps DC to prove flame.

The flame current microamp signal must be checked as part of regular maintenance and during normal service checks in order to properly diagnose the ignition system.

The flame current microamp signal can be measured with many of the new digital volt OHM meters. However, there are many digital meters which do not have microamp scales but can read DC volts.

The flame current is measured by removing the flame sensor wire at the flame sensor and connecting it to one of the meter leads. The other meter lead is connected to the flame sensor.

A flame current adapter for digital volt meters, Pub. No. 34-4816-01, see next page, is available which allows flame current microamps to be measured on the DC volt scale. The adapter has two leads with a male and female quick connect for easy hook up to the flame sensor.

There is also a flame current tester and simulator kit, Pub. No. 34-4817-01, that provides capability to measure flame current with a digital DC volt meter and the ability to simulate flame current, check for adequate ground and confirm gas valve operation. See next page for additional information.

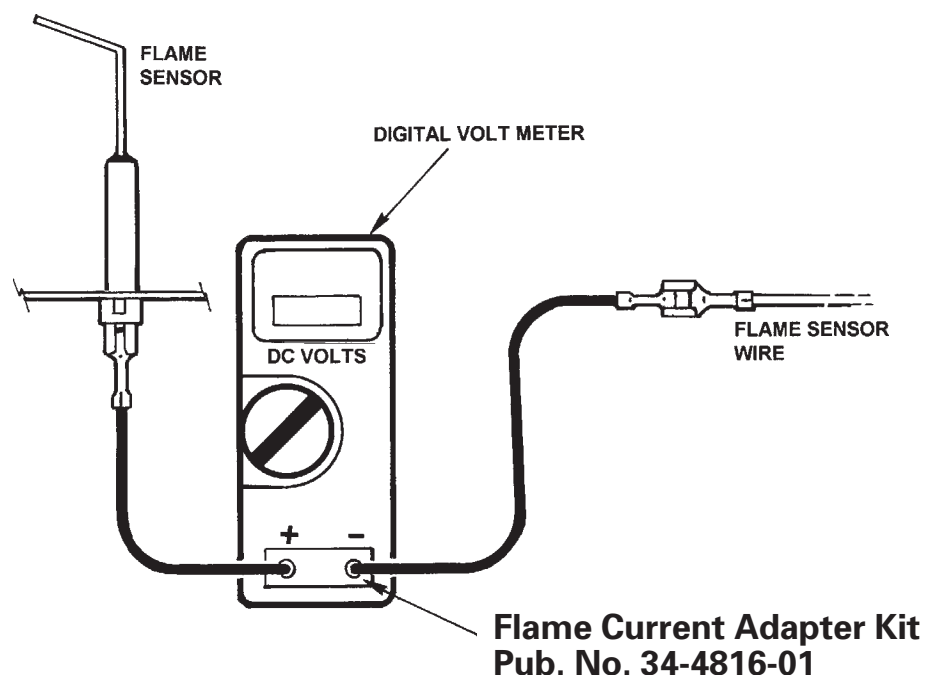

White-Rodgers Flame Current Tester/Simulator

To Be Used With The Following White-Rodgers Control Models:

50E47-060, 50A50 and 50A51 series

May be used on other ignition modules that have a separate (remote) flame current sensor rod.

Note 1

Remember – System lock out is normal if line voltage, 115V.A.C., leads are not connected to the furnace module correctly. Hot leg to hot line and neutral line to neutral terminal.

2 Flashes – System Locked Out – White-Rodgers Control Series number 50A50 or 50A51

To Measure Flame Current

1. Unhook white wire from flame sensor probe.
2. Connect white wire removed in Step 1 to the white lead on the tester.
3. Connect the black lead to the flame sensor probe.
4. Plug in a digital V.O.M. into the jacks on the tester. Set V.O.M. to the D.C. volt scale. Meter must be a minimum of 10 megohms resistance on the D.C. volt scale.
5. Repower furnace and put in a call for heat.
6. Read the V.O.M. Voltage read equals microamps, or 2 volts equals 2 microamps.

To Simulate Flame Current

1. Hook up tester and meter as above.
2. White-Rodgers Control number 50E47-060 Connect the green wire to “TR” terminal at the White-Rodgers Control. White-Rodgers Control number 50A50 Series or number 50A51 Series connect the green wire to the Burner Frame.
3. Connect the red wire to the gas valve hot lead, normally the red wire on current furnaces. Use a V.O.M. to determine which lead is the hot lead, if in doubt.
4. Repower furnace and put in a call for heat. Push red button down on the tester until the light comes on. Release the button at this time. If light will not come on, gas valve is not receiving 24 VAC power, go to Step 5.
5. Does the furnace continue to heat? Yes/No

Yes	No	
W.R. Module is OK, check:	Did light on tester come on? Yes/No	
<ol style="list-style-type: none"> 1. Flame sensor 2. Burner ground 3. Rusty burner 4. Burner not making good electrical connection. 5. Flame not burning on flame sensor rod. 	<p>Yes</p> <ol style="list-style-type: none"> 1. Check gas valve, gas flow and hot surface ignitor if furnace did not come on. 2. Check white wire from flame current sensor going to module. 3. Check burner frame ground wire. Move green tester wire from burner frame to module ground terminal and retest furnace. If furnace now will stay on, fault is in the burner grounding. 4. Remember note number 1. 5. If number 2, number 3, and number 4 above did not correct problem, replace module. 	<p>No</p> <ol style="list-style-type: none"> 1. Check connection and voltage at gas valve. 2. Move green tester wire to module ground terminal. This applies only to furnaces using a number 50A50 or number 50A51 control. The tester green lead should already be connected to the “TR” terminal on furnaces using a number 50E47-060 control. 3. Retest furnace – if no 24 VAC at gas valve, check wiring and transformer. If wiring and transformer are OK, replace module.

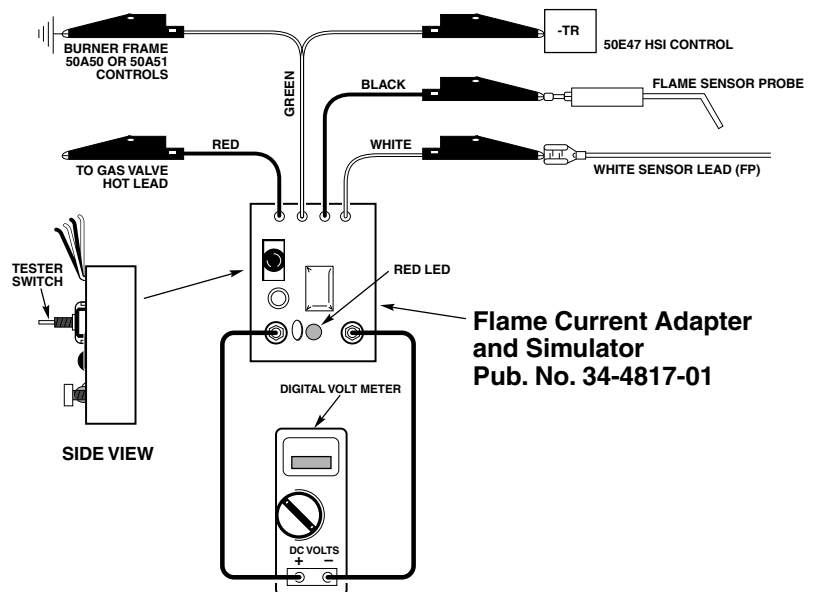

Combustion Air Pressure Switch Check – Measurement

The combustion air pressure switch proves operation of the induced draft motor and that adequate air is provided to ensure complete combustion of the fuel being supplied to the burner.

The induced draft motor and vent system performance can be checked by connecting an inclined manometer to the pressure switch hose and measuring the operating static pressure.

The direct vent furnaces have differential pressure switches and require two connections to the manometer. See figure below.

The measured static pressure reading should be compared to the pressure switch specifications. If the measured static pressure meets or exceeds the specifications and the switch contacts will not transfer the following items should be checked:

1. Switch out of calibration
2. Defective pressure switch
3. Moisture in pressure switch tubing
4. Condensate trap or drain restricted (90% furnaces)
5. Incorrect switch installed

If the measured static pressure reading does not meet the switch specifications, the following items should be checked:

1. Pressure switch hose/tubing for cracks or loose connections.
2. Inducer wheel for corrosion or loose blades.
3. Inducer for tight bearings or loose inducer wheel.
4. Vent system design (oversized/undersized/long lateral runs)
5. High altitude switches required at 4,000 ft. or more above sea level.
6. Crack in heat exchanger.
7. Flue box gaskets leaking.

Note:

The switch setting and the last three digits of the factory drawing number are stamped on the switch. Example: "PO1", - .50" WC.

The "PO1" and "PO2" must not be interpreted as "PS1" and "PS2" on two stage models.

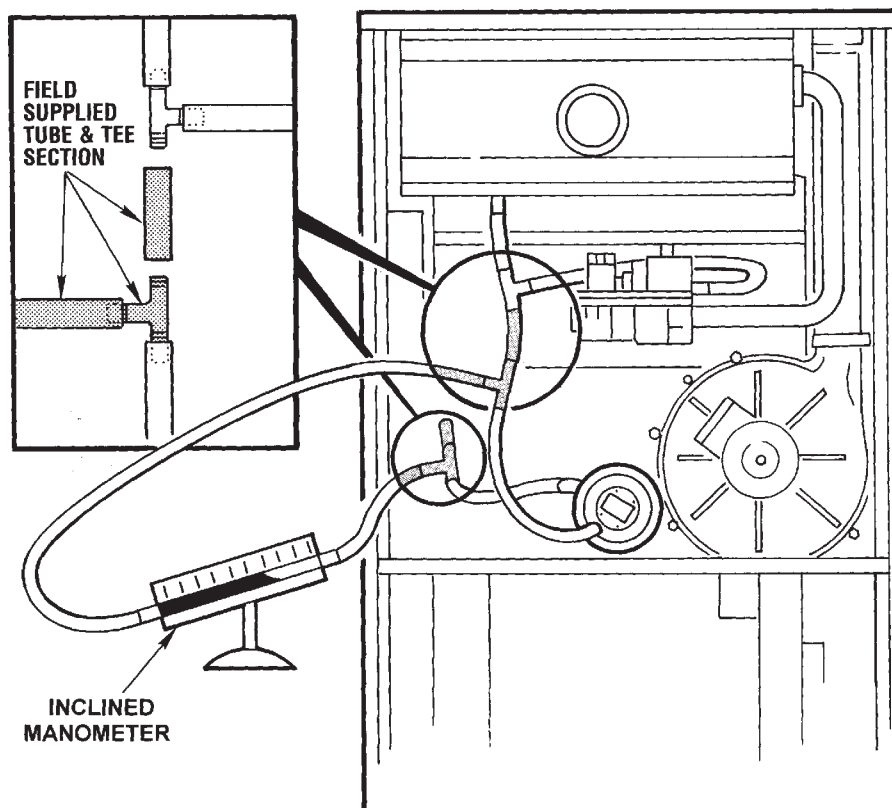

Furnace Pressure Switch Settings

Models	Closing Pressure In W.C.	Opening Pressure In W.C.	Factory Number	Replacement Number	High Altitude Kit	Closing Pressure In W.C.	Opening Pressure In W.C.	Factory Number	Replacement Part
*UD-C-A, B, C, D/*DD-C, A, B	-0.65	-0.5 ± .05	C340071P01	SWT 1255	BAYHALT220	-0.56	-0.41 ± .04	C340071P03	SWT 1579
*UD-C-H/*DD-C-C②	-0.65	-0.5 ± .05	C340773P01	SWT02357	BAYHALT238	-0.56	-0.41 ± .04	C340773P03	CNT03814
*UD-R-A, B/*DD-R-A, B	HI -0.65	-0.5 ± .05	C340071P01	SWT 1255	BAYHALT215	HI -0.56	-0.41 ± .04	C340071P03	SWT 1579
	LO -0.31	-0.17 ± .03	C340191P02	SWT 1373	③	LO -0.31	-0.14 ± .03	C340191P04	SWT 1580
*UD-R-H/*DD-R-C②	HI -0.65	-0.5 ± .05	C340773P01	SWT02357	BAYHALT239	HI -0.56	-0.41 ± .04	C340773P03	CNT03814
	LO -0.31	-0.17 ± .03	C340789P02	SWT02357	③	LO -0.31	-0.14 ± .03	C340789P04	N/A
*UE-A-A, B/*DE-A-A, B	-0.65	-0.5 ± .05	C330610P01	SWT 1600	BAYHALT224	-0.56	-0.41 ± .04	C330610P03	N/A
*UE-A-H, K/*DE-A-C, K②	-0.65	-0.5 ± .05	C340773P01	SWT02357	BAYHALT238	-0.56	-0.41 ± .04	C340773P03	CNT03814
*UJ-A	-0.65	-0.5 ± .05	C330610P01	SWT 1600	BAYHALT224	-0.56	-0.41 ± .04	C330610P03	N/A
FUA/FCA-A-A	-0.65	-0.5 ± .05	C340071P01	SWT 1255	BAYHALT220	-0.56	-0.41 ± .04	C340071P03	SWT 1579
FUA/FCA-A-B, C	-0.65	-0.5 ± .05	C330610P01	SWT 1600	BAYHALT224	-0.56	-0.41 ± .04	C330610P03	N/A
FUA/FCA-A-D, E	-0.65	-0.5 ± .05	C340773P01	SWT02357	BAYHALT238	-0.56	-0.41 ± .04	C340773P03	CNT03814
*UC/*DC040C	-1.55	-1.40 ± .04	C340450P04	SWT 1633	BAYHALT228	-1.27	-1.09 ± .04	C340450P08	N/A
*UC/*DC060C	-1.27	-1.04 ± .04	C340450P01	SWT 1630	BAYHALT226	-1.02	-0.86 ± .04	C340450P06	N/A
*UC/*DC080, 120C	-1.51	-1.39 ± .04	C340450P03	SWT 1632	BAYHALT225	-1.27	-1.04 ± .04	C340450P01	SWT 1630
*DC100C948	-1.64	-1.46 ± .04	C340450P02	SWT 1631	BAYHALT228	-1.27	-1.09 ± .04	C340450P08	N/A
*UC100C948	-1.55	-1.40 ± .04	C340450P04	SWT 1633	BAYHALT225	-1.27	-1.04 ± .04	C340450P01	SWT 1630
*UC100C960	-1.41	-1.23 ± .04	C340450P09	SWT 1776	BAYHALT240	-1.16	-1.00 ± .04	C340450P10	N/A
*UX/*DX040C, *UX100C960①	-1.44	-1.29 ± .04	C340545P01	SWT 1669	BAYHALT230	-1.21	-1.06 ± .04	C340545P05	N/A
*UX060C①	-1.09	-0.94 ± .04	C340545P02	SWT 1670	BAYHALT231	-0.92	-0.77 ± .04	C340545P06	N/A
*DX060C①	-1.13	-0.98 ± .04	C340545P12	SWT 1838	BAYHALT241	-0.97	-0.82 ± .04	C340545P13	N/A
*UX080C942①	-1.30	-1.15 ± .04	C340545P03	SWT 1671	BAYHALT232	-1.09	-0.94 ± .04	C340545P02	SWT 1670
*UX100C948① *UX/*DX120C960①	-1.55	-1.40 ± .04	C340545P04	SWT 1672	BAYHALT233	-1.30	-1.15 ± .04	C340545P03	SWT 1671
*DX080C942①	-1.52	-1.37 ± .04	C340545P09	SWT 1702	BAYHALT233	-1.30	-1.15 ± .04	C340545P03	SWT 1671
*DX100C948①	-1.55	-1.40 ± .04	C340545P04	SWT 1672	BAYHALT234	-1.44	-1.29 ± .04	C340545P01	SWT 1669
*UY/*DY060, 080H① *DY120R①	LO -1.09	-0.94 ± .04	C340545P02	SWT 1670	BAYHALT235	LO -0.92	-0.77 ± .04	C340545P06	SWT 1862
	HI -1.76	-1.59 ± .05	C340545P08	SWT 1699	③	HI -1.44	-1.29 ± .04	C340545P01	SWT 1669
*UY100R①	LO -1.30	-1.15 ± .04	C340545P03	SWT 1671	BAYHALT236	LO -1.09	-0.94 ± .04	C340545P02	SWT 1670
	HI -1.76	-1.59 ± .05	C340545P08	SWT 1699	③	HI -1.44	-1.25 ± .04	C340545P01	SWT 1698
*DY100R①	LO -1.30	-1.15 ± .04	C340545P03	SWT 1671	BAYHALT237	LO -0.92	-0.77 ± .04	C340545P26	N/A
	HI -1.94	-1.75 ± .06	C340545P11	SWT 1710	③	HI -1.63	-1.44 ± .04	C340545P27	N/A
*UY120R①	LO -1.09	-0.94 ± .04	C340545P02	SWT 1670	BAYHALT242	LO -0.92	-0.77 ± .04	C340545P06	SWT 1862
	HI -1.63	-1.48 ± .04	C340545P07	SWT 1698	③	HI -1.30	-1.15 ± .04	C340545P03	SWT 1671

① The pressure switches for the *UX/*DX/*UY/*DY furnaces are differential switches.

② The mounting method for 80+ furnace pressure switches changed with the introduction of the upflow/horizontal models in the 1st quarter of 1996. Those changes are reflected in this table.

③ These kits contain both pressure switches.

Note: Switches listed on this page by model number are the latest switch listed as of 3/18/98 and may not have the same set point as the original factory installed switch.

Check T.S.B for the latest changes.

* Models may be an A or T or F.

Installation

The superceded switches are low pressure, single pole, normally open pressure control switches and are no longer available. Switch, SWT02357 and Control, CNT03814, are functional replacements, although there are some minor differences between the two. The replacement control is a high and low pressure unit. When used as replacements for single stage furnaces, terminate the wires on the normally open and common terminals on the HIGH-pressure side of

the switch, see below. When used to replace one or both of the switches on a two stage furnace, both original switches need to be removed and discarded. Connect the wiring for low fire to the LOW pressure side and connect the wiring for high fire to the HIGH pressure side. Discard the "T" for the pressure hose connections and connect the pressure switch hose to the negative pressure connector, see below.

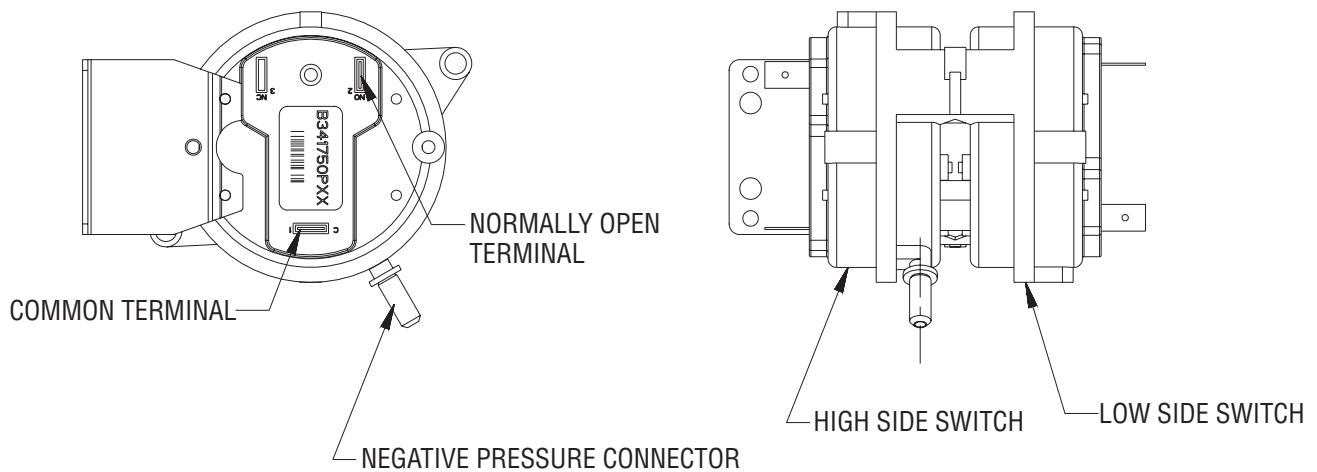

SWT02357 and CNT03814

Gas Valves

Furnace Model	Production Gas Valve	Recommended Replacement	
		Natural	Propane/LP
FUA/FCA-A-A	A	B	B
FUA/FCA-A-B,C	E	E	E
*UC-C-A,B/*DC-C-A,B,C	A,B ^①	B	B
*UD-C-A,B,H/*DD-C-A,B,C,D,J,K	A,B ^①	B	B
*UD/*DD-R-A	C	C,G,K,L ^②	D,G,K,L ^②
*UE/*DE-A-A,B	E	E	E
*UJ-A-A	E	E	E
*UX/*DX-C-A	F	F	F
*UY/*DY-R-A	G ^②	G ^②	G ^②
FUA-A-E/FCA-A-E TUE-A-K/TDE-A-K	H	H	H
*UX/*DX-C-C	I	I	I
*UC-C/*DC-C-C *UD-C-H/*DD-C-C ^③	J	J	J
*UD-R-K/*DD-R-F	L ^②	L ^②	L ^②
*UX-R-V, W/*DX-R-V, W	L ^②	L ^②	L ^②
*UY-R-V, W/*DY-R-V, W	L ^②	L ^②	L ^②
*UE-A-L/*DE-A-M	M	M	M
*UX/*DX-C-C, D ^④	N	N	N
*UD-C-K/*DD-C-F ^④	O	O	O
*UE-A-L/*DE-A-M ^④	N	N	N
*UC-C-B/*DC-C-B ^④	O	O	O

* Models may be an A or T or F.

① Factory change from fast to slow opening valve in January, 1994.

② "G," "K" or "L" valves approved for natural or propane.

③ Factory Change, April, 1996 (L19 Datecode).

④ Factory Change, August, 2001.

Gas Valves

Valve	Models	Supplier	Opening Characteristics	Factory Outlet Pressure Settings	Propane Convertible	Replacement Part No.		
						Gas Valve	LP Spring	Natural Spring
A	36E01-221	White-Rodgers	Fast	3.3 in W.C.	Yes	VAL-2905	KIT-1401	KIT-1402
B	36E98-205	White-Rodgers	Slow	3.3 in W.C.	Yes	VAL-4335	KIT-1401	KIT-1402
C	36E96-211	White-Rodgers	2-Stage	1.4-1.7 in W.C. 3.0-3.7 in W.C.	No	VAL-3625	Natural Only	
D	36E96-214	White-Rodgers	2-Stage	4.0-4.5 in W.C. 10.0-10.5 in W.C.	LP Valve	VAL-3774	Propane Only	
E	36E35-201	White-Rodgers	Fast	3.3 in W.C.	Yes	VAL-4210	KIT-1401	KIT-1402
F	36E36-282	White-Rodgers	Fast	3.3 in W.C.	Yes	VAL-4307	KIT-1401	KIT-1402
G	36E96-227	White-Rodgers	2-Stage	1.4-1.7 in W.C. 3.0-3.5 in W.C. See Note	Yes	VAL-4420	Dual Purpose Valve Operates on Natural or Propane	
H	36E22-207	White-Rodgers	Fast ^①	3.3 in W.C.	Yes	VAL-4858	KIT-1401	KIT-1402
I	36E22-205	White-Rodgers	Fast ^①	3.3 in W.C.	Yes	VAL-4855	KIT-1401	KIT-1402
J	36E24-205	White-Rodgers	Slow ^①	3.3 in W.C.	Yes	VAL-4854	KIT-1401	KIT-1402
K	36E96-237	White-Rodgers	2-Stage	1.4-1.7 in W.C. 3.0-3.5 in W.C. See Note	Yes	VAL-4564	Dual Purpose Valve Operates on Natural or Propane	
L	36E54-201	White-Rodgers	Fast ^① 2-Stage	1.4-1.7 in W.C. 3.0-3.5 in W.C. See Note	Yes	VAL-6376	Dual Purpose Valve Operates on Natural or Propane	
M	36E22-209	White-Rodgers	Fast ^①	3.3 in W.C.	Yes	VAL-6377	KIT03831 or BAYLPKT210A ^②	
N	36F22-209	White-Rodgers	Fast ^①	3.0-3.5 in W.C.	Yes	VAL06969	KIT03831 or BAYLPKT210A ^②	
O	36F22-205	White-Rodgers	Slow ^①	3.0-3.5 in W.C.	Yes	VAL06968	KIT03831 or BAYLPKT210A ^②	

① Has toggle switch safety shut off.

② Natural Spring number KIT-1402.

Note: It is necessary to adjust the "Hi" fire setting to maximum rate (turn adjustment screw clockwise until it bottoms) before setting the "Lo" propane fire rate, otherwise the "Lo" fire rate of 4.0-4.5" W.C. cannot be set above the 3.5" W.C. natural gas "Hi" fire setting. Model 36E96-227 is shipped for natural gas. If it is used with propane these are your settings: 4.0-4.5" and 10.5-11.0" in W.C.

Manifold Pressure Settings

The 40" gas furnaces are shipped from the factory for use with natural gas. Conversion to propane requires a change in the main burner orifices. The single stage White-Rodgers gas valve, 36E01, also requires the installation of an LP regulator spring. The two stage furnaces (R-Models) with White-Rodgers gas valve, 36E96, type 211 require a gas valve change for LP fuel. The two stage gas valve, 36E96 type 227, used in the *UY/*DY-R furnace is a dual purpose

valve and does not require a regulator spring change for LP conversion.

Note: It is necessary to adjust the "Hi" fire setting to maximum rate (turn adjustment screw clockwise until it bottoms) before setting the "Lo" propane fire rate, otherwise the "Lo" fire rate of 4.0 – 4.5" W.C. cannot be set above the 3.5" W.C. natural gas "Hi" fire setting.

* Models may be an A or T.

MAIN BURNER ORIFICE DRILL SIZE	TYPE FUEL	FINAL MANIFOLD PRESSURE SETTING	
		1ST STAGE	2ND STAGE ^①
44	NATURAL	1.4-1.7" W.C	3.0-3.2" W.C.
45 ^②	NATURAL	1.4-1.7" W.C	3.0-3.7" W.C.
55	PROPANE	4.0-4.5" W.C	9.0-9.5" W.C.
56 ^③	PROPANE	6.0-6.2" W.C	10.5-11.0" W.C.

① Applies to single stage models also.

② Factory change from 44 to 45 orifices in January 1994.

③ LP kit orifices changed from 55 to 56 in August 1994.

Single Stage (Typical)

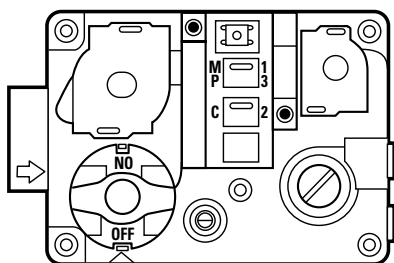

Remove the slotted screw to adjust manifold pressure. Using a flat blade screwdriver or allen wrench, turn the adjustment screw clockwise (in) to increase pressure and (out) to decrease gas pressure.

Single Stage (Toggle Switch)

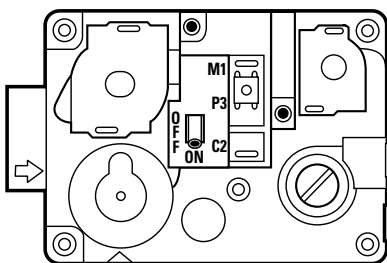

Remove the slotted screw to adjust manifold pressure. Using a flat blade screwdriver or allen wrench, turn the adjustment screw clockwise (in) to increase pressure and (out) to decrease gas pressure.

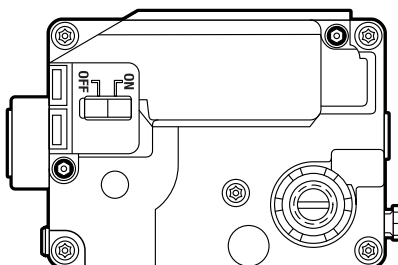

Two-Stage (VAL4564 has Toggle Switch)

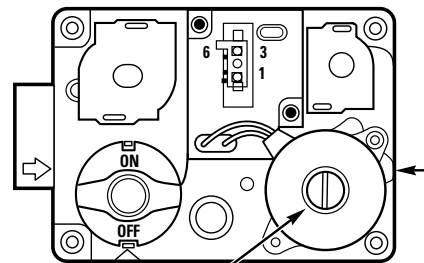

1st Stage (LO) Manifold Pressure Adjustment

2nd Stage (HI) Manifold Pressure Adjustment

Remove the slotted screw on top of the gas valve for 1st stage (LO) manifold pressure adjustment. Remove slotted screw on outlet side for 2nd stage (HI) manifold adjustment.

Turn the adjustment nut clockwise (in) to increase the gas flow rate, and counter clockwise (out) to decrease the gas pressure using a 3/32" hex wrench.

Direct Vent Manifold Pressure Check

The 40" Direct Vent furnaces (single and two stage) reference the burner box inlet static to provide proper gas valve regulation. The burner box static pressure varies with the different inlet vent pipe lengths and ambient air conditions. Therefore, the gas valve regulator must be able to reference the box pressure to maintain a constant manifold setting. The gas valve vent port has a barbed hose fitting which connects with a "tee" fitting to the burner box and combustion air switches.

When setting or checking the gas valve outlet manifold pressure, the manometer must be connected to both the gas valve outlet pressure tap and the burner box pressure hose, see figures below.

Note: The final manifold pressure will be higher than the reading indicates if the burner box hose is not connected. The actual manifold pressure will be off by the same amount as the burner box static pressure.

Example: 3.50" W.C. gas valve outlet pressure tap reading,

-.15" W.C. burner box inlet pressure hose not connected.

3.65" W.C. actual manifold pressure instead of desired 3.5 in. W.C.

The burner box pressure hose does not have to be connected to set the outlet manifold pressure if the burner box front cover is removed.

Correct Method of Checking Direct Vent Manifold Pressure with Burner Box Referenced is shown below.

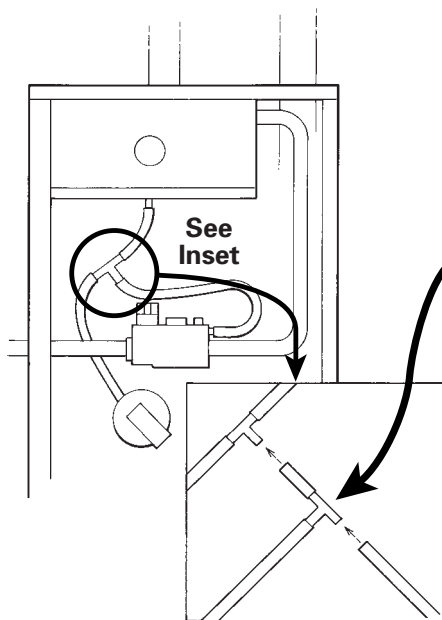

Separate the tube at the unit Tee and reconnect with a short piece of field supplied tube and another Tee with the "U" Manometer attached.

Be sure to reconnect burner box tubing to original position after testing the manifold pressure!

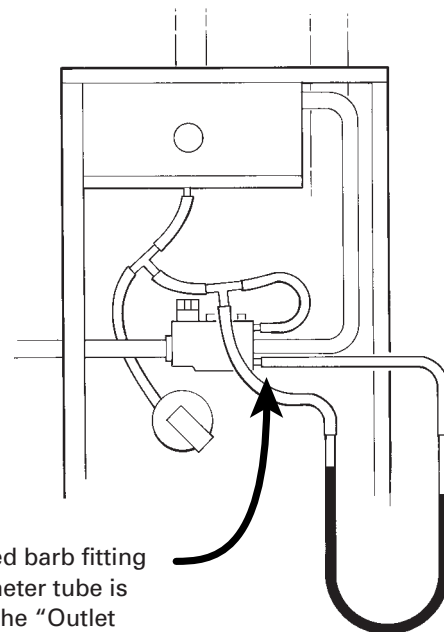

Field supplied barb fitting with manometer tube is attached to the "Outlet Pressure Tap" on the outlet side of the gas valve.

Determining Natural Gas Furnace Input

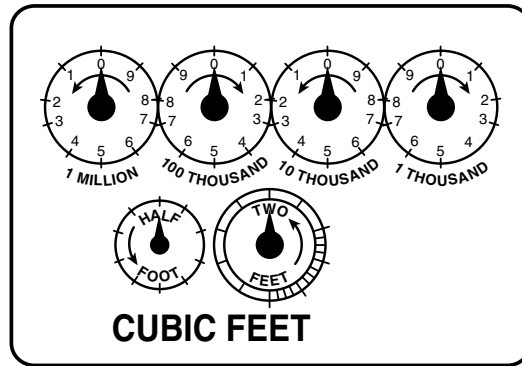

- Measure the time taken for two revolutions of the two cubic foot dial.
- Call gas supplier for BTU/Cu.Ft. Heating value of gas
 - or –
- Use 1000 BTU/Cu.Ft. as value
(If specific value not available)
- * Heating value of gas based on sea level pressure.
- Calculate Input:

$$\text{Cu.Ft./Hour} = \frac{\text{Revolutions} \times \text{Cu.Ft./Revolution} \times 3600}{\text{Time (In Seconds)}}$$

$$\text{BTUH} = \text{Cu.Ft./Hour} \times \text{BTU/Cu.Ft.}$$

Important: Input should never exceed 100% of rated input.
Adjust manifold pressure or change main orifice size if required

Calculating CFM – Temperature Rise Method

$$\text{CFM} = \frac{\text{BTUH (Output)}}{\Delta T \times 1.08}$$

Minimum steady state efficiency – 80%

– Use AFUE if over 80%

$$\text{BTUH (out)} = \text{BTUH (in)} \times \frac{\text{Efficiency}}{100}$$

Example:

• BTUH (in) = 80,000

• AFUE = 90%

• BTUH (out) = 80,000 x .90
= 72,000

• ΔT = 45°

$$\text{CFM} = \frac{72,000}{45 \times 1.08}$$

= 1481

Single Stage Twinning Kit

BAYTWIN400A – For use with all 40" furnaces with White-Rodgers 50A50 integrated furnace controls.

The BAYTWIN400A Twinning Kit is used when twinning upflow furnaces with identical model numbers. These identical furnaces must have the same gas input and airflow.

The return air must be common to both furnaces and enter through the bottom only. Return air cannot enter through the back or sides. The reverse flow switches must be mounted in the blower compartment to prevent furnace operation if one of the blowers is inoperative. Without a reverse flow switch, the supply air will recirculate through the furnace with the inoperative blower and overheat.

The indoor thermostat must energize the "G" circuit in heating (Electric Heat T-Stat) in order to start both blowers simultaneously. There will not be a heating fan on delay period. The 24 volt transformers must be in phase with each other (10 volts or less between furnace "R" terminals) and each furnace must be connected to the same leg or phase of the 115 volt power source.

A connection between "Y" and "G" on each furnace low voltage terminal is necessary to operate both fans at the same speed during heating and cooling.

Typical Installations with a Coil

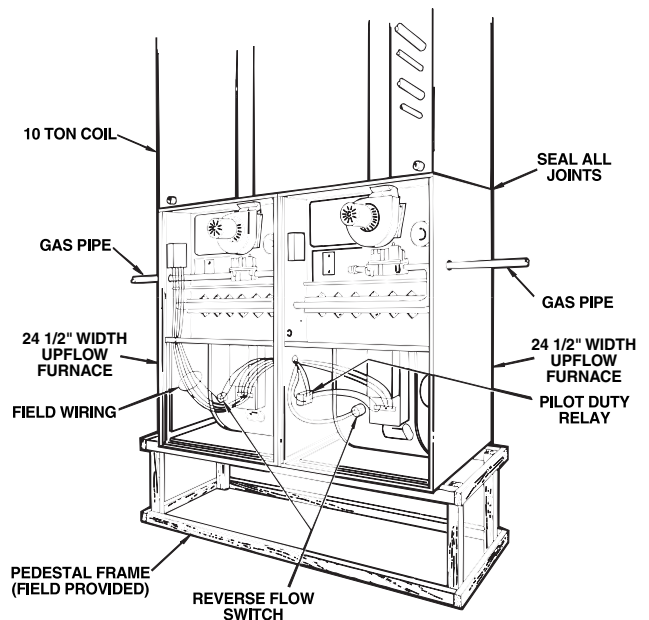
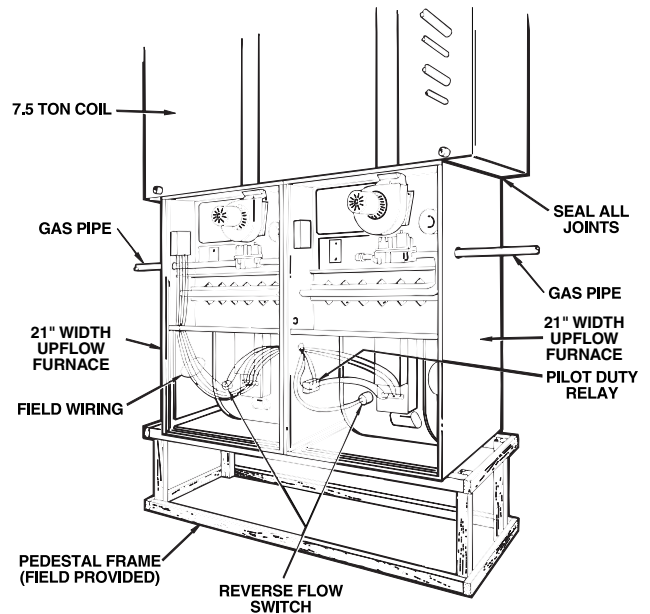

Field Wiring Diagram for Single Stage Thermostat and Single Stage Furnace, Outdoor Unit Without Transformer

LEGEND

- RFS. REVERSE FLOW SWITCH
- IFC INTEGRATED FURNACE CONTROL
- RELAY A PILOT DUTY RELAY (PROVIDED)

NOTES:

1. REVERSE FLOW SWITCHES MUST BE INSTALLED ON EACH FURNACE BLOWER HOUSING.
2. THERMOSTAT MUST ENERGIZE "G" WITH A CALL FOR HEAT. AS IN ELECTRIC HEAT MODELS.
3. CIRCULATING FAN WILL RUN WITH ZERO TIME DELAY ON CALL FOR HEAT.
4. 24 VOLT TRANSFORMERS ON FURNACES MUST BE PHASED PROPERLY.
5. IF OUTDOOR UNIT HAS A 24 VOLT TRANSFORMER, ISOLATING RELAY MUST BE INSTALLED (FIELD SUPPLIED). USE PILOT DUTY RELAY SUCH AS RLY0975.
6. INCREASE THERMOSTAT HEAT ANTICIPATOR SETTING. IF APPLICABLE, BY ADDING THE CURRENT FROM RELAY "A" TO THE ANTICIPATOR SETTING SHOWN ON FURNACE WIRING DIAGRAM.

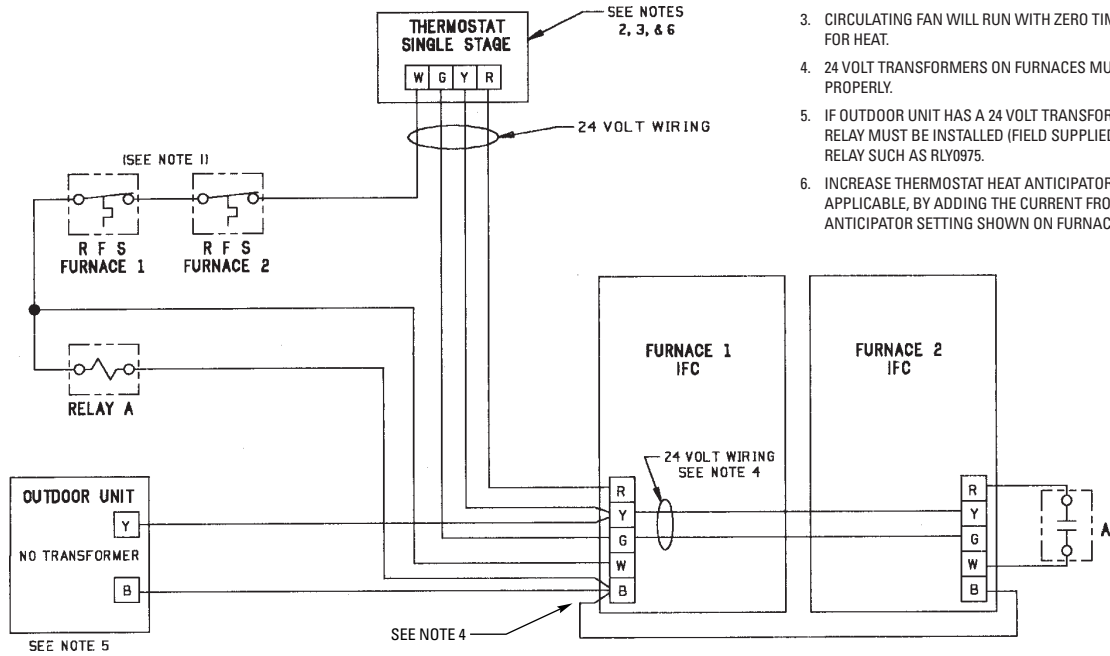

From Dwgs. 21B148309 Rev. 1

Field Wiring Diagram for Two Stage Thermostat and Single Stage Furnace, Outdoor Unit Without Transformers

LEGEND

- RFS. REVERSE FLOW SWITCH (PROVIDED)
- IFC INTEGRATED FURNACE CONTROL
- RELAY A PILOT DUTY RELAY (PROVIDED)

NOTES:

1. REVERSE FLOW SWITCHES MUST BE INSTALLED ON EACH FURNACE BLOWER HOUSING.
2. THERMOSTAT MUST ENERGIZE "G" WITH A CALL FOR HEAT. AS IN ELECTRIC HEAT MODELS.
3. CIRCULATING FAN WILL RUN WITH ZERO TIME DELAY ON CALL FOR HEAT.
4. 24 VOLT TRANSFORMERS ON FURNACES MUST BE PHASED PROPERLY.
5. IF OUTDOOR UNIT HAS A 24 VOLT TRANSFORMER, ISOLATING RELAY MUST BE INSTALLED (FIELD SUPPLIED). USE PILOT DUTY RELAY SUCH AS RLY0975.
6. INCREASE THERMOSTAT HEAT ANTICIPATOR SETTING. IF APPLICABLE, BY ADDING THE CURRENT FROM RELAY "A" TO THE ANTICIPATOR SETTING SHOWN ON FURNACE WIRING DIAGRAM.

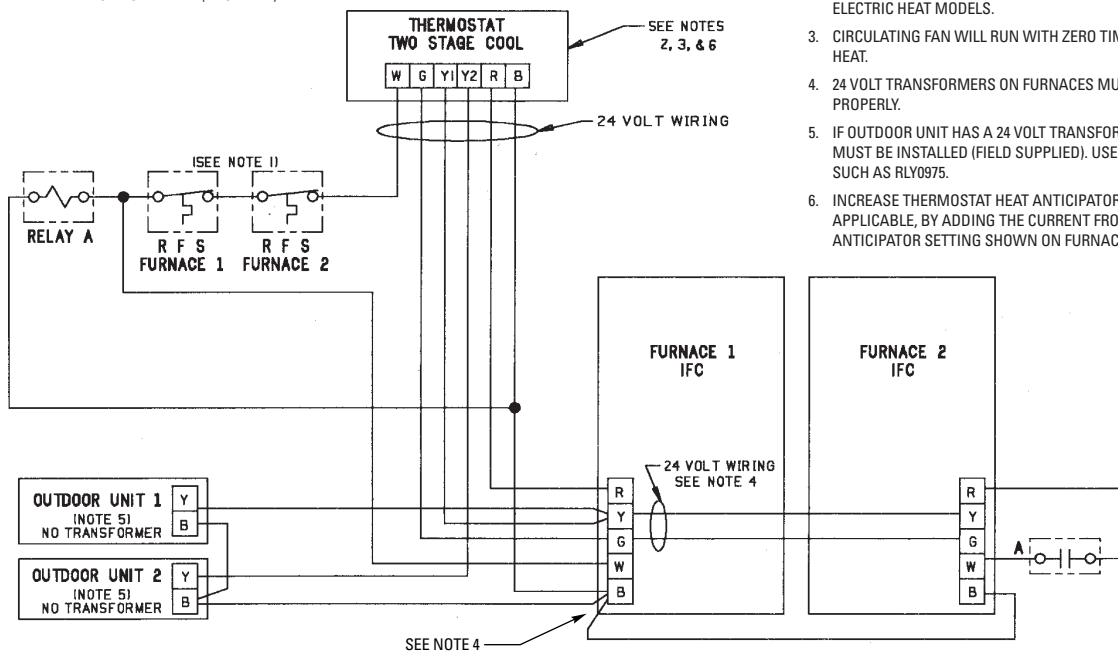

From Dwgs. 21B148311 Rev. 1

Two Stage Twinning Kit

BAYTWIN300A – For use with all two stage 40" furnaces with White-Rodgers 50A51-405 ignition controls.

The BAYTWIN300A Kit includes a twinning harness that connects to each of the furnace controls to provide synchronization of heating and cooling operation. The twinning cable ties directly into the output of the ignition control microprocessor and sends a duplicate command to the second furnace through the twinning cable. An electric heat thermostat is not required with the two stage models because the twinning cable will start both blowers at the same time when either furnace outputs a signal.

The BAYTWIN300A Kit is for use with upflow furnaces and bottom return only. The 24 volt transformers must be in phase and both furnaces must be connected to the same leg or phase of the 115 volt power supply.

The reverse flow switches provided in the kit will prevent overheating due to recirculation of supply air should one furnace motor become inoperative.

Typical Installations with a Coil

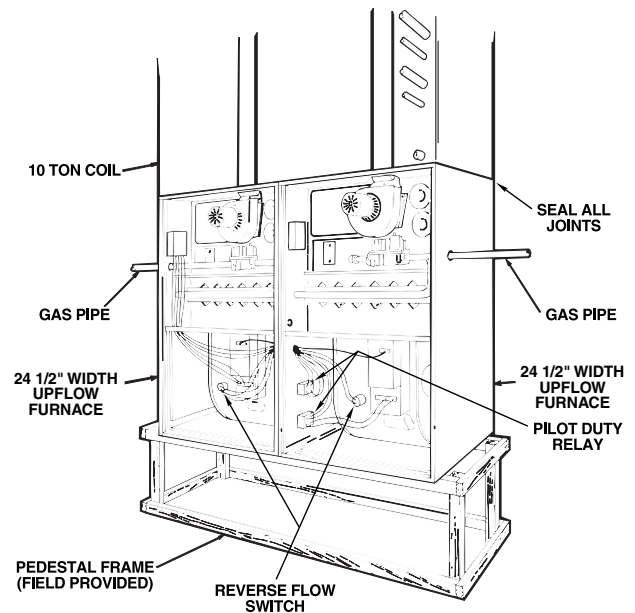
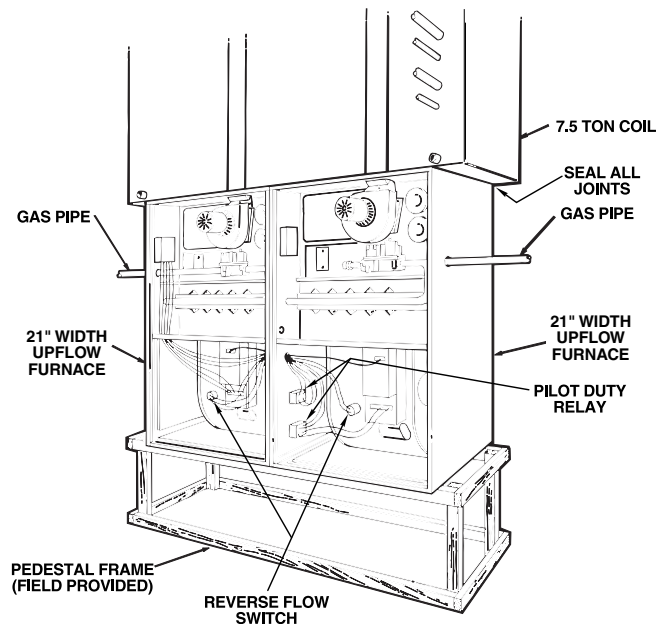

Field Wiring Diagram for Twinning *UD-R Furnaces with Two Stage Heat and Single Stage Cooling Thermostat

LEGEND

- RFS. REVERSE FLOW SWITCH (PROVIDED)
- IFC INTEGRATED FURNACE CONTROL
- RELAY A PILOT DUTY RELAY (PROVIDED)

NOTES:

1. REVERSE FLOW SWITCHES MUST BE INSTALLED ON EACH FURNACE BLOWER HOUSING.
2. IF OUTDOOR UNIT HAS A 24 VOLT TRANSFORMER, ISOLATING RELAY MUST BE INSTALLED (FIELD SUPPLIED). USE PILOT DUTY RELAY SUCH AS RLY0975.
3. CONNECT SPECIAL TWINNING CABLE (PROVIDED) BETWEEN INTEGRATED FURNACE CONTROLS.
4. 24 VOLT TRANSFORMERS ON FURNACES MUST BE PHASED PROPERLY.

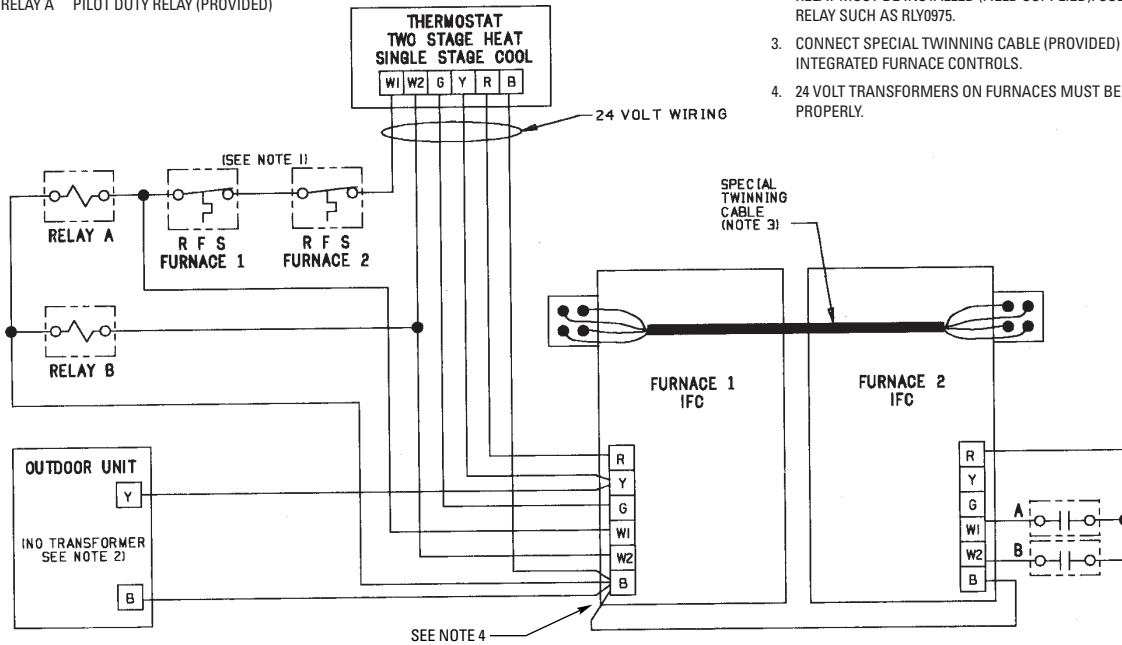

* Models may be an A or T

From Dwgs. 21B148296 Rev. 0

Field Wiring Diagram for Twinning *UD-R Furnaces with Two Stage Heat and Two Stage Cooling Thermostat

LEGEND

- RFS. REVERSE FLOW SWITCH (PROVIDED)
- IFC INTEGRATED FURNACE CONTROL
- RELAY A PILOT DUTY RELAY (PROVIDED)

NOTES:

1. REVERSE FLOW SWITCHES MUST BE INSTALLED ON EACH FURNACE BLOWER HOUSING.
2. IF OUTDOOR UNIT HAS A 24 VOLT TRANSFORMER, ISOLATING RELAY MUST BE INSTALLED (FIELD SUPPLIED). USE PILOT DUTY RELAY SUCH AS RLY0975.
3. CONNECT SPECIAL TWINNING CABLE (PROVIDED) BETWEEN INTEGRATED FURNACE CONTROLS.
4. 24 VOLT TRANSFORMERS ON FURNACES MUST BE PHASED PROPERLY.

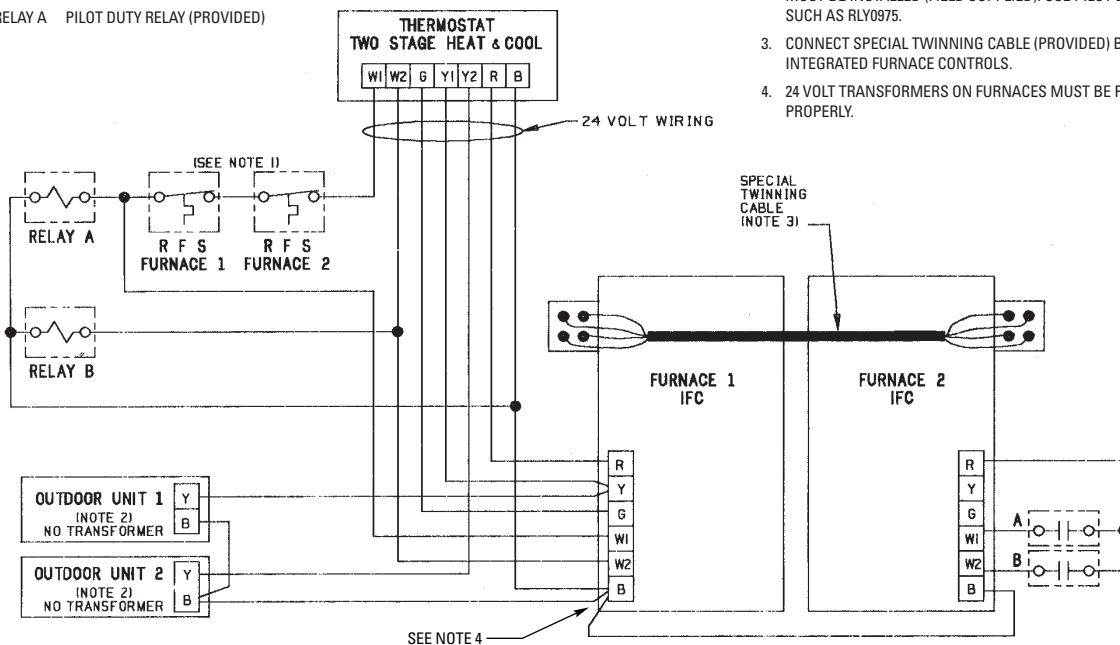

* Models may be an A or T

From Dwgs. 21B148297 Rev. 0

Single Wire Twinning – For Models with Twin Terminals

Twinning Connection Diagram for Twinning 1 Stage Furnaces with Single Wire Twinning Feature 1 Stage Heating Only Thermostat

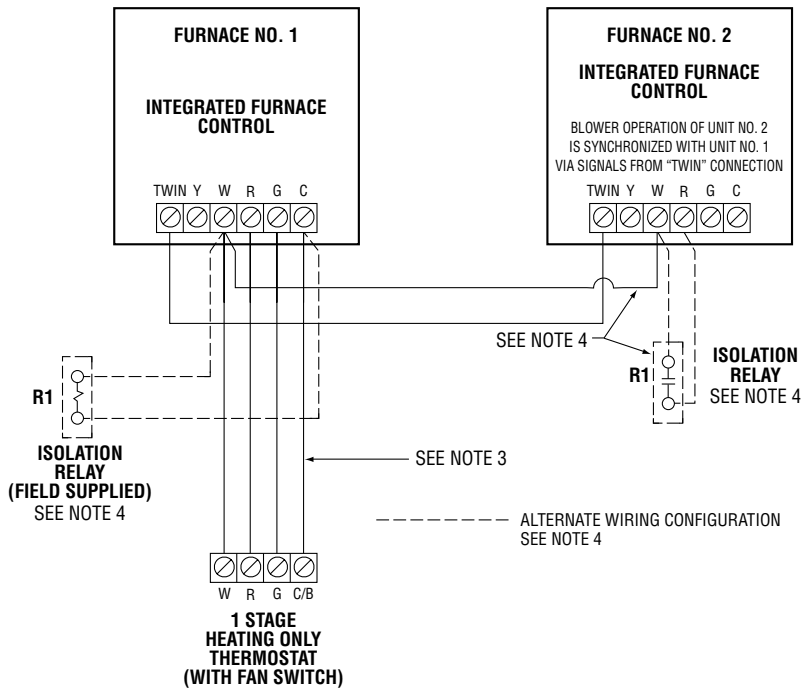

NOTES:

1. BOTH FURNACES MUST BE POWERED FROM THE SAME 115V. LEG OF CIRCUIT PANEL.
2. INSURE 24V. FURNACE TRANSFORMERS ARE IN PHASE. PRIOR TO COMPLETING CONNECTIONS, CHECK VOLTAGE BETWEEN "R" TERMINALS OF EACH FURNACE. IF VOLTAGE IS GREATER THAN 10V., REVERSE THE "BL" AND "RD" SECONDARY LEADS ON ONE OF THE FURNACE TRANSFORMERS.
3. CONNECTION MAY BE REQUIRED FOR ELECTRONIC THERMOSTAT.
4. IF CURRENT EXCEEDS THERMOSTAT CURRENT RATING, USE ISOLATION RELAYS "RI" AS SHOWN. (DO NOT CONNECT "W" TO "W") ISOLATION RELAY NOT NEEDED IF THE THERMOSTAT CONTACTS ARE RATED AT 1.0A. OR ABOVE.

Twinning requires that two furnaces with the same configuration, capacity and airflow must be used. They shall have common returns with equal pressure drops or ducts with equivalent lengths and sizes.

From Dwg. 21B341422 Rev. 1

Twinning Connection Diagram for Twinning 1 Stage Furnaces with Single Wire Twinning Feature 1 Stage Heating/1 Stage Cooling Thermostat

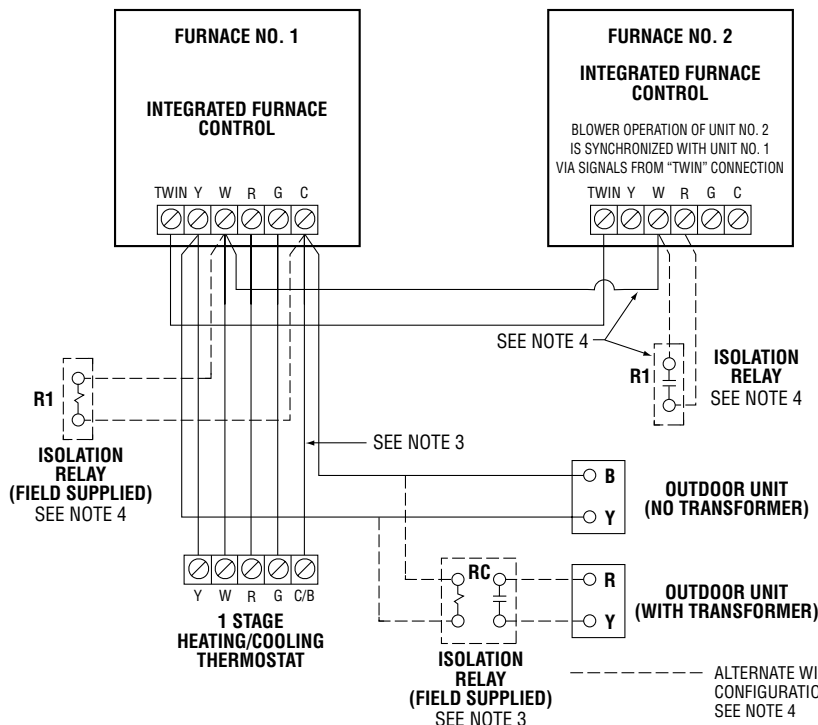

NOTES:

1. BOTH FURNACES MUST BE POWERED FROM THE SAME 115V. LEG OF CIRCUIT PANEL.
2. INSURE 24V. FURNACE TRANSFORMERS ARE IN PHASE. PRIOR TO COMPLETING CONNECTIONS, CHECK VOLTAGE BETWEEN "R" TERMINALS OF EACH FURNACE. IF VOLTAGE IS GREATER THAN 10V., REVERSE THE "BL" AND "RD" SECONDARY LEADS ON ONE OF THE FURNACE TRANSFORMERS.
3. IF OUTDOOR UNIT HAS A 24V. TRANSFORMER, AN ISOLATION RELAY MUST BE INSTALLED. (FIELD SUPPLIED – USE PILOT DUTY RELAY "RC", SUCH AS RLY0975.) SEE ALTERNATE CONNECTION.
4. IF CURRENT EXCEEDS THERMOSTAT CURRENT RATING, USE ISOLATION RELAYS "RI" AS SHOWN. (DO NOT CONNECT "W" TO "W") ISOLATION RELAY NOT NEEDED IF THE THERMOSTAT CONTACTS ARE RATED AT 1.0A. OR ABOVE.
5. CONNECTION MAY BE REQUIRED FOR ELECTRONIC THERMOSTATS.

From Dwg. 21B341423 Rev. 1

White-Rodgers Radiant Sense Ignition Controls

There were four versions, of the 50A52-100 Radiant Sense Controls and three versions of the 50A52-101 control and one version of the 50A52-102. The different versions of the 50A52-100 control, as shown on next page, can be identified by the

engineering code applied to the back of the control board in black ink. The number of relays and the type of radiant sensor used can also add in identifying the different controls. If one of the controls is to be replaced use KIT 5216.

Furnace Model	White-Rodgers Controls	Eng Code	Furnace Model	White-Rodgers Controls	Eng Code
FUA-A-B0	50A52-100	E90, E91	*UE/*DE-A-A1	50A52-100	E92
FCA/FUA-A-B1	50A52-100	E92	*UE/*DE-A-B0	50A52-101	E2
FCA/FUA-A-C0	50A52-101	E2	*UJ-A-A	50A52-101	E93, E1, E2
*UE-A-A0	50A52-100	E90, E91	BAYLPKT212/KIT-2537	50A52-100	E93

* Models may be an A or T

Version 4 (50A52-100 E93) controls were used in the BAYLPKT212/212A LP Kit and KIT-2537 to provide a safety lockout. The 12 pin polarized connector was rotated 180° from earlier versions and requires rotating of the furnace 12 pin wiring harness 180° in order to mate with the control.

Version 4 of the 50A52-100 (E93) control and the 50A52-101 (E93, E1, E2, E3) are microprocessor based 2-try controls. The 50A52-101/102 controls have a plastic protective housing and LVTB screw terminals.

Controls	Eng. Code	Radiant Sensor	Number	Replacement Part
Version 1 50A52-100	E90	SPST (2 wire)	7 Relays	CNT-1581/KIT 5216
Version 2 50A52-100	E91	SPST (2 wire)	6 Relays	CNT-1581/KIT 5216
Version 3 50A52-100	E92	SPDT (3 wire)	6 Relays	CNT-1643/KIT 5216
Version 4 50A52-100 ^①	E93	SPDT (3 wire)	5 Relays	CNT-1655/KIT 5216
Version 4 50A52-101 ^①	E93, E1, E2, E3	SPDT (2 wire)	5 Relays	CNT-1670/KIT 5216
Version 4 50A52-102	E90, E4	SPDT (2 wire)	5 Relays	CNT-1845/KIT 5216

^① 2-try 100% lockout controls (auto reset after 3 hours)

Radiant Sense Ignition Control Timing

Description	Engineering Code	Control Specifications
Hot Surface Ignitor		
Initial Warm-up Period	E90, E91, E92 E93, E1, E2, E3 ^③ *	<ul style="list-style-type: none"> - 25 seconds typical (application dependent) - 17 seconds minimum, 90 seconds maximum^② (microprocessor controlled)
	E90, E4 ^③ *	<ul style="list-style-type: none"> - *12 seconds minimum, 30 seconds maximum^②
Flame Failure Response		
Radiant Sensor Cool Down Period	E90, E91, E92, E93	<ul style="list-style-type: none"> - 90 seconds maximum
Radiant Sense Control		
Ignition Retries (before lockout) (3 hour auto reset on E93, E1, E2)	E90, E91, E92 E93, E1, E2	<ul style="list-style-type: none"> - Unlimited - Constant retry - 1 after initial try (2 total)^②
Ignition Recycles	E90, E91, E92 E93, E1, E2 ^③	<ul style="list-style-type: none"> - Unlimited - Constant recycle - 2 Recycles - infinite if flame switch transfers after 90 seconds sensor timer expires
Inducer Motor		
Pre purge	E90, E91, E92 E93, E1, E2 ^③	<ul style="list-style-type: none"> - 0 seconds (inducer on during HSI warm up) - 0 seconds first try. 60 seconds during retry
Post purge	E90, E91, E92, E93	<ul style="list-style-type: none"> - 0 seconds
Indoor Blower Motor		
Heating On Fan Delay	E90, E91, E92, E93, E1, E2	<ul style="list-style-type: none"> - Approximately 45 seconds after gas valve is energized
Heating Off Fan Delay	E90, E91, E92, E93, E1, E2	<ul style="list-style-type: none"> - Approximately 90 seconds after gas valve is de-energized
Cooling Off Fan Delay	E90, E4	<ul style="list-style-type: none"> - 90 seconds field adjustable

^② Control will lockout after 90 seconds if flame switch radiant sensor never transfers to the hot position. Inducer and indoor motor are de-energized.

^③ Radiant Sensor must be in cold position before control will energize ignitor.

Identifying Radiant Sense Controls

50A52-100 Version 1 (E90)

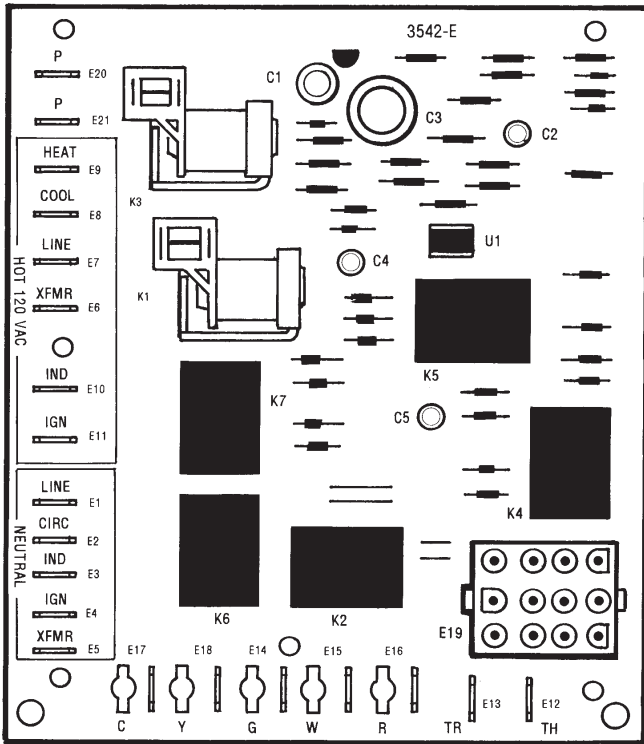

E90 – Cooling fan runs when limit opens

50A52-100 Versions 2 and 3 (E91, E92)

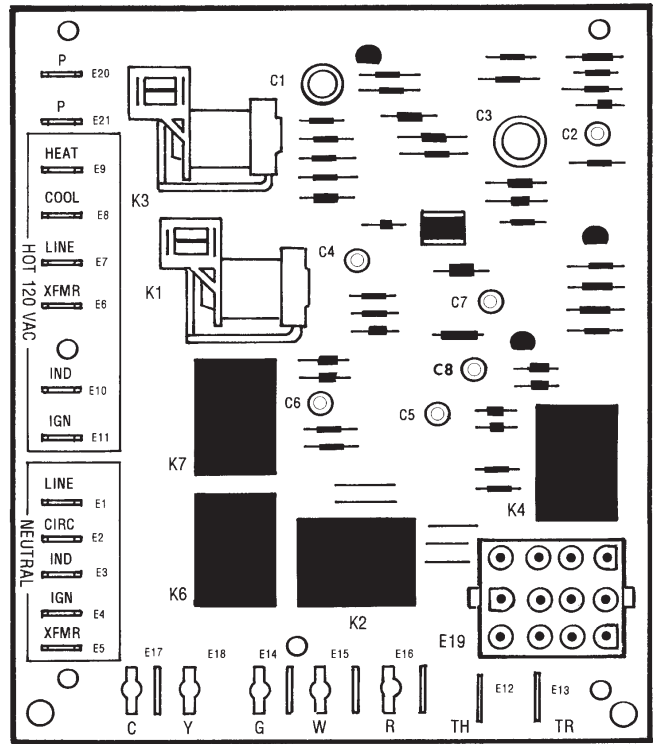

E91 – Heating fan runs when limit opens in heating only.
E92 – SPDT Radiant Sensor

50A52-100 Version 4 (E93)

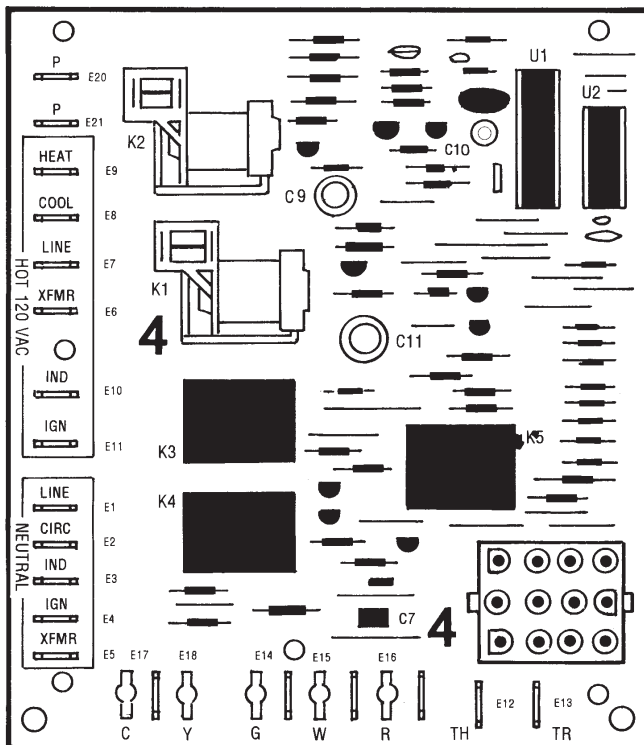

E93 – 2 try lock out control. Used in BAYLPKT212/212A and Kit 2537 only.

50A52-101 Version 4 (E93, E1, E2, E3) 50A52-102 (E90, E4)

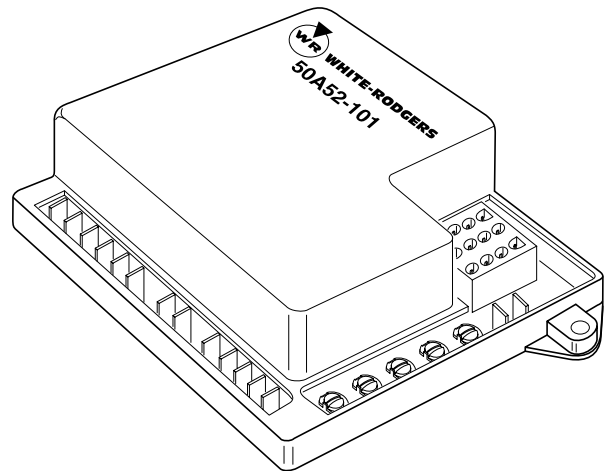

E93, E1 – Same as 50A52-100 E93 with addition of protective housing and LVTB screw connections.

E2 – Radiant sensor must be in cold position before hot surface ignitor can be energized.

E3, E90, – 12 second minimum, 30 second maximum HSI
E4 – warm-up time.

50A52-102

E90, E4 – 90 second indoor fan off delay in cooling mode.

Radiant Energy Sensor

S.P.D.T. ASSEMBLY VIEW

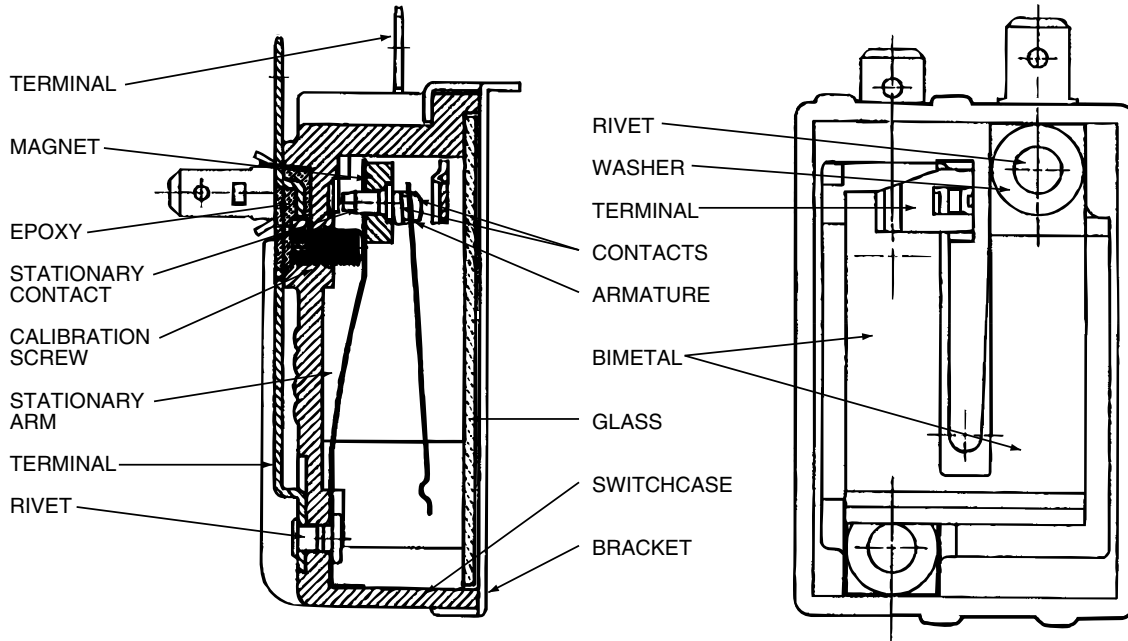

S.P.D.T. PICTORIAL VIEW

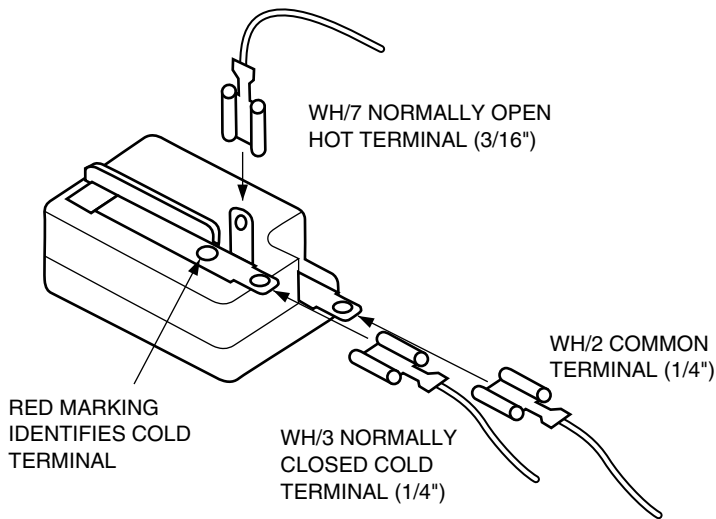

Caution!

Do Not alter the position of the ignitor or the gas may not light. The ignitor must be located within the burner face as shown at right.

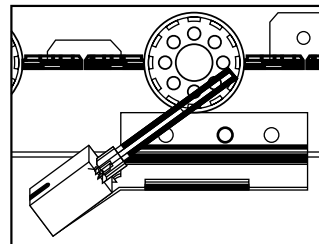

Fig. 2 18-CN12P23-1

White-Rodgers 50A52-100 Sequence of Operation

Version 1 (E90) 7 Relays, 2 Wire Flame Switch Radiant Sensor

This control allows a constant re-try for ignition after a flame failure.

When the disconnect is in the "ON" position, ① power is applied through the blower door interlock switch ② to the control line voltage input terminal ⑥ and out of the control to the primary side of the control transformer "XFMR" ⑦. The low voltage side of the transformer ⑩ supplies 24 Volts to the control through terminals "TH" and "TR" ③①. Control terminal "R" ③① supplies 24 volts to the "R" terminal on the room thermostat.

24 Volt Power On

When 24 volt power is present at terminals TH and TR on the furnace control, relay **K 5** ②⑧ will be energized through the flame roll-out fuse link and limit switch ②⑩. (On horizontal and downflow models, an additional limit switch and fuse link may be used.) The normally closed **K 5A** contacts open ③① and the normally open **K 5B** contacts close ③①. This prevents the **K 1** cooling relay ③① from being energized until power is applied to the "G" terminal ③① on the furnace control.

Note: If the limit switch or the flame roll-out fuse link opens, relay **K 5** ②⑧ will be de-energized and the normally closed **K 5A** contacts ③① will complete a circuit to the **K 1** cooling relay ③①. The indoor blower motor will run on the cooling speed selected.

Typical Start Up

On a call for heat, the indoor thermostat completes the circuit from the R terminal to W then through the limit switch and roll-out fuse link to the common contact of the combustion air pressure switch ①⑧ and thus to relays **K 2** and **K 7** ①⑧.

When relay **K 2** ①⑧ is energized, its **K 2A** contacts close ①⑦, providing a holding circuit for itself. Contacts **K 7** ①⑧ also close, and start the Induced Draft Motor ①①.

When the Induced Draft Blower comes up to speed, the combustion pressure switch trips, connecting power (through the flame switch NC radiant sensor bi-metal) ②①, to relays **K 4** and **K 6** ②③.

When relay **K 6** ②③ is energized, its contacts ⑨ connect line power to the ignitor ①①. Also, normally open contacts **K 4B** ②⑥ close, bypassing the EQSO (Electrical Quick Shut Off) resistor ②④ and allowing the redundant gas valve ②⑥ to pull in. Normally closed contacts **K 4A** ②⑦ open, removing power from the **K 3** ②⑨ fan time delay circuit and the main gas valve. As the ignitor heats up, its' radiant energy is sensed by the flame switch radiant sensor bi-metal which will cause the contacts to open. When the contacts open, relays **K 6** and **K 4** ②③ are de-energized allowing contacts **K 6** to open ⑨, de-energizing the ignitor. At the same time, normally

open contacts **K 4B** ②⑥ open, but the redundant valve is held open due to the EQSO resistor in series with the RV coil. Normally closed contact **K 4A** ②⑦ closes, allowing the main valve to open (thus gas flows and ignition takes place) and the **K 3** fan time delay circuit starts the time delay to start the indoor blower ④ (normally a 45 second delay), then warm air circulation begins.

Typical Shut Down

When the thermostat is satisfied and power is removed from the "W" terminal ③①, the gas valve is de-energized. The time delay circuit keeps contacts **K 3** ④ closed for approximately 90 seconds to allow all of the heat to be extracted from the furnace. When the contacts open, the indoor blower stops.

Circuit Safety Features

The circuit is arranged to prove that the combustion blower is operating. The pressure switch ①⑧ must always start in the normally closed position and then trip to an open position, proving that the switch is functioning. This also proves that the Induced Draft Motor ①① is circulating air through the furnace.

The flame switch radiant sensor bi-metal ②① controls relay **K 4**. Its contacts maintain safe operation of the gas valve. If the flame switch is open at the start of a cycle, the redundant valve ②⑥ cannot open due to the normally open contacts **K 4B** ②⑥. (The EQSO resistor provides current flow enough to hold the valve open, but will not allow it to open from a closed position).

If the limit switch opens, (due to high heat exchanger temperature), it will power the indoor blower by de-energizing relay **K 5** ②⑧, thus energizing relay **K 1** ③① and turning on the blower on cooling speed ⑤.

A momentary power interruption will cause relay **K 2** ①⑧ to de-energize and break its holding circuit ①⑦. This will cause the circuit to restart only after the pressure switch closes again, proving its operation.

A momentary gas interruption will cause the flame switch radiant sensor bimetal ②① to start cooling. In about 30 seconds, the switch will close, energizing relay **K 4**, ②③ thus opening the normally closed contact **K 4A** ②⑦ closing the main gas valve ②⑦ and stopping gas flow. Relay **K 6** and **K 4** ②③ will be energized, and a new start up cycle will begin.

Note: This furnace has been certified to allow unburned gas to flow for a stated "flame failure response time" and then be ignited without excessive flame roll-out.

The roll-out fuse link will open the circuit and stop gas flow if it is overheated due to a flame roll-out. (On downflow and horizontal models, an additional limit switch or fuse link may be used.) As an example, this may occur with a blocked flue. At this time, the indoor blower will be powered on the selected **cooling speed**.

Wiring Schematic

Version 1 Radiant Sense Control

115 VOLT 60 HZ. 1PH. POWER SUPPLY
PER LOCAL CODES

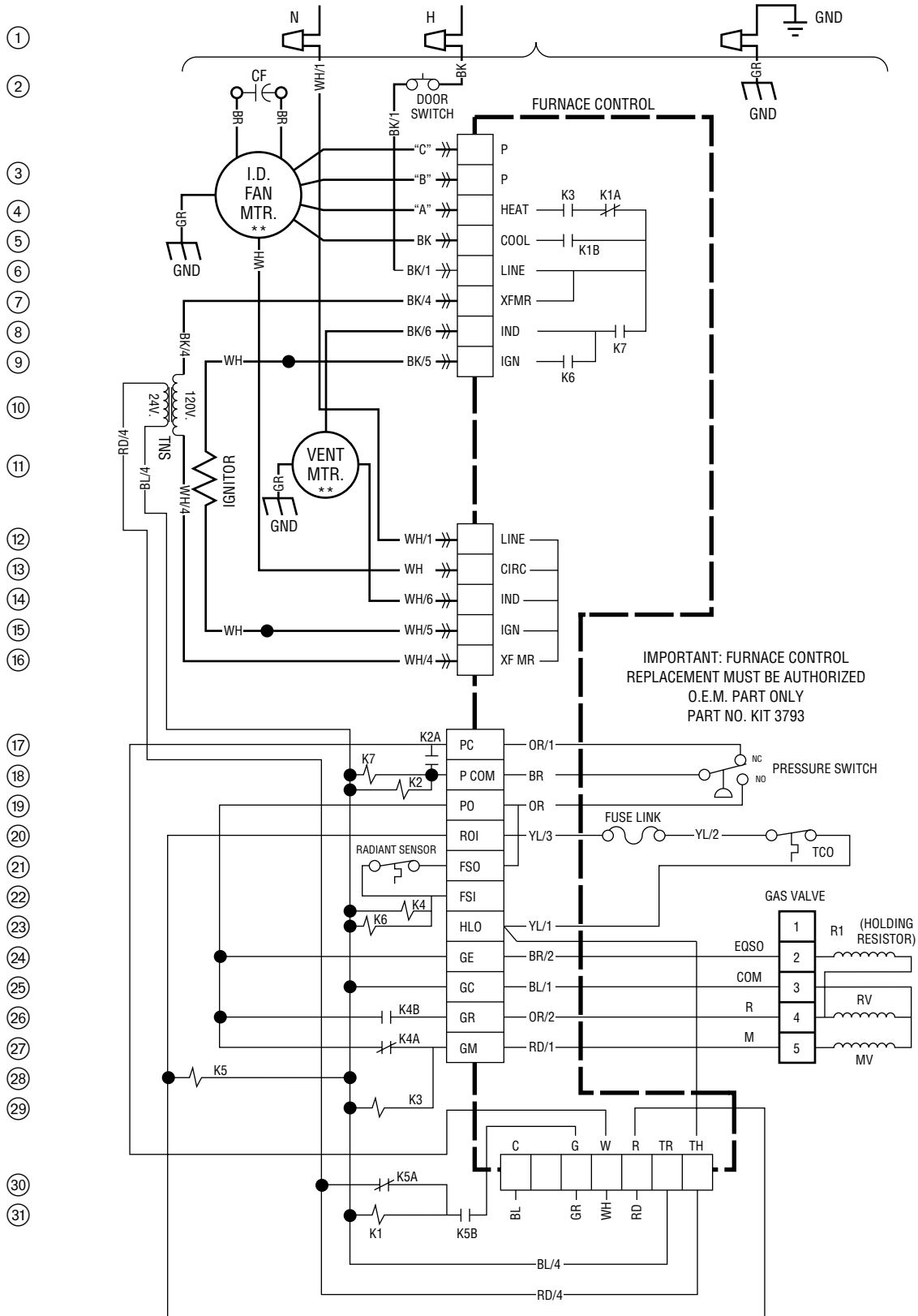

White-Rodgers 50A52-100 Sequence of Operation

Version 2 (E91) 6 Relays, 2 Wire Flame Switch Radiant Sensor

This control allows a constant re-try for ignition after a flame failure.

When the disconnect is in the "ON" position, power is applied through the blower door interlock switch ① to the control line voltage input terminal ④ and out of the control to the primary side of the control transformer "XFMR" ⑤. The low voltage side of the transformer ⑧ supplies 24 volts to the control through terminals "TH" and "TR" ②⑦. Control terminal "R" ②⑦ supplies 24 volts to the "R" terminal on the room thermostat.

24 Volt Power On

When 24 volt power is present at terminals TH and TR ②⑦ on the furnace control, no relays are activated. The **K 1** cooling relay ②⑧ will only be energized when power is applied to the "G" terminal ②⑦ on the furnace control. If a limit switch trips or a fuse link ①⑧ fails, the indoor fan motor ② will run at the chosen heating speed ②.

Typical Start Up

On a call for heat, the indoor thermostat completes the circuit from the "R" terminal to W. It connects power from the transformer to the common contact of the combustion air pressure switch ①⑥ through the limit switch and roll-out fuse link ①⑧ and thus to relays **K 2** and **K 7** ①⑥. (On downflow and horizontal models an additional limit switch and fuse link may be used.)

When relay **K 2** is energized ①⑥, its **K 2A** contacts close ①⑤, providing a holding circuit for itself. Contacts **K 7** also close ①⑥, and start the Induced Draft Motor ⑨.

When the induced draft blower comes up to speed, the combustion pressure switch ①⑥ trips, connecting power through the flame switch radiant sensor bi-metal ①⑨ to relays **K 4** and **K 6** ②①.

When relay **K 6** is energized, its contacts connect line power to the ignitor ⑦. Also, normally open contacts **K 4B** close ②④, bypassing resistor EQSO (Electrical Quick Shut Off) ②② and allowing the redundant gas valve ②④ to pull in. Normally closed contacts **K 4A** open ②⑤, removing power from the fan **K 3** time delay circuit ②⑥ and the main gas valve. As the ignitor heats up ⑨, its radiant energy is sensed by the flame switch radiant sensor's bi-metal ①⑨ which will cause its contacts to open. When the contacts open, relays **K 6** and **K 4** ②① are de-energized allowing contacts **K 6** ⑦ to open, de-energizing the ignitor. At the same time, normally open contacts **K 4B** ②④ open, but the redundant valve ②④ is held open due to the EQSO resistor in series with the RV coil ②②. Normally closed contact **K 4A** closes, allowing the main valve to open (thus gas flows and

ignition takes place) and the **K 3** fan time delay circuit ②⑥ starts the time delay to start the indoor blower (normally a 45 second delay), then warm air circulation begins.

Typical Shut Down

When the thermostat is satisfied and power is removed from the "W" terminal ②⑦, the gas valve is de-energized. The time delay circuit keeps contacts **K 3** ② closed for approximately 90 seconds to allow all of the heat to be extracted from the furnace. When the **K 3** contacts open ②, the indoor blower stops, unless constant fan has been selected.

Circuit Safety Features

The circuit is arranged to prove that the combustion blower ⑨ is operating. The pressure switch ①⑥ must always start in the normally closed position ①⑤ and then trip to an open position ①⑦, proving that the switch is functioning. This also proves that the Induced Draft Motor ⑨ is circulating air through the furnace.

The flame switch radiant sensor bi-metal ①⑨ controls relay **K 4** ②①. Its contacts maintain safe operation of the gas valve. If the flame switch radiant sensor bi-metal is open at the start of a cycle, the redundant valve ②④ cannot open, due to the normally open contacts of relay **K 4B** ②④. (Resistor EQSO provides current flow enough to hold the valve open, but will not allow it to open from a closed position.)

If the limit switch ①⑧ opens, due to high heat exchanger temperature, relay **K 3** ②⑥ will power the indoor blower on the selected heating speed ②.

A momentary power interruption will cause relay **K 2** to de-energize ①⑥ and break the holding circuit ①⑤. This will cause the furnace to restart only after the pressure switch ①⑥ closes again, proving its operation.

A momentary gas interruption will cause the flame switch radiant sensor bi-metal ①⑨ to start cooling. In about 30 seconds, the switch will close energizing relay **K 4** ②①, thus opening the normally closed contact **K 4A** ②⑤, closing the main valve ②⑤ and stopping gas flow. Relay **K 6** and **K 4** will be energized, and a new start up cycle will begin.

Note: This furnace has been certified to allow unburned gas to flow for a stated "flame failure response time" and then be ignited without excessive flame roll-out.

The roll-out fuse link will open the circuit and stop gas flow if it is overheated due to a flame roll-out. (On downflow and horizontal models an additional limit switch and fuse link may be used.) As an example, this may occur with a blocked flue. At this time, the indoor blower will be powered on the selected **heating speed**.

Wiring Schematic

Version 2 Radiant Sense Control

115 VOLT 60 HZ. 1PH. POWER SUPPLY
PER LOCAL CODES

- ①
- ②
- ③
- ④
- ⑤
- ⑥
- ⑦
- ⑧
- ⑨
- ⑩
- ⑪
- ⑫
- ⑬
- ⑭
- ⑮
- ⑯
- ⑰
- ⑱
- ⑲
- ⑳
- ㉑
- ㉒
- ㉓
- ㉔
- ㉕
- ㉖
- ㉗
- ㉘

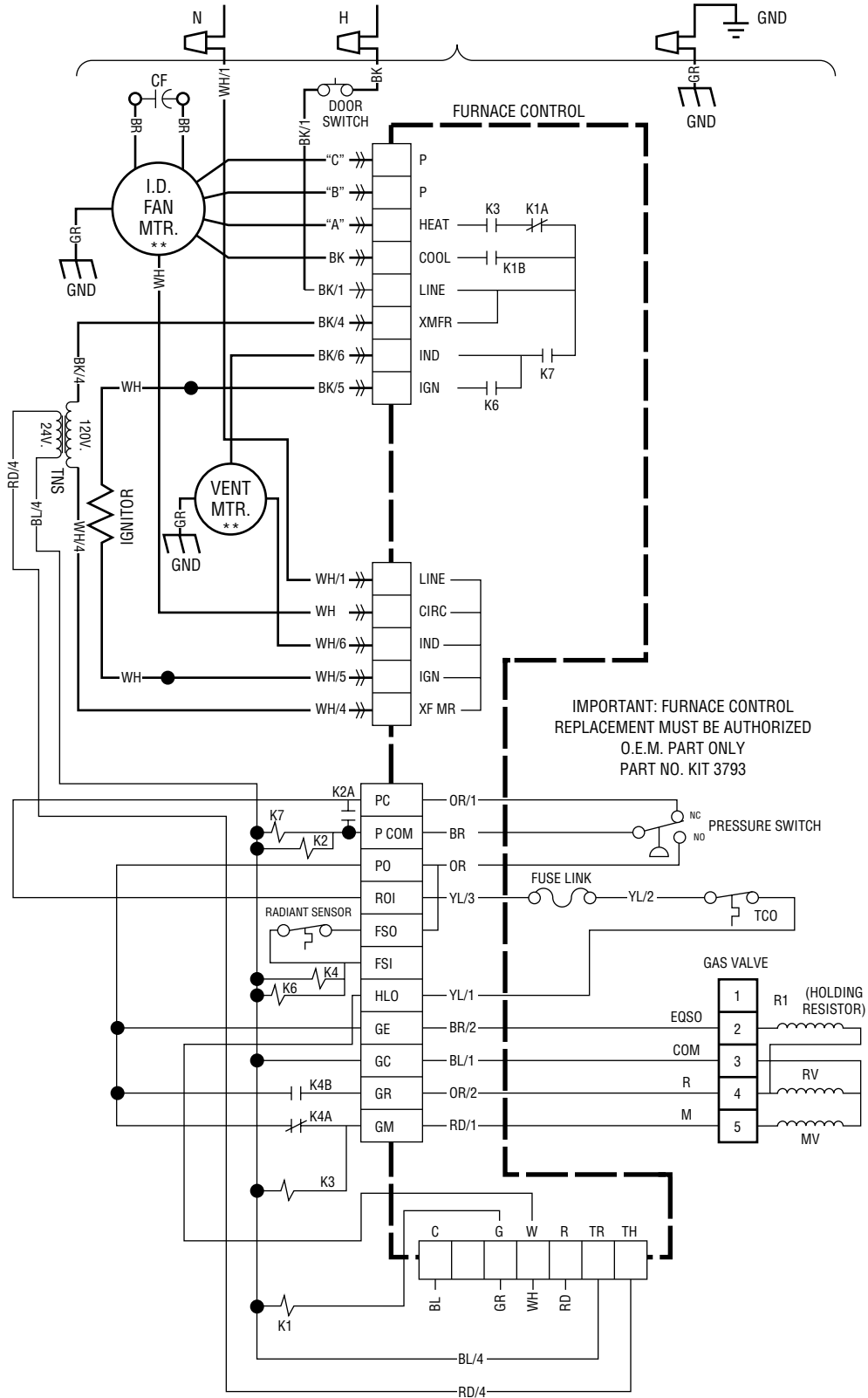

White-Rodgers 50A52-100 Sequence of Operation

Version 3 (E92) 6 Relays, 3 Wire Flame Switch Radiant Sensor

This control allows a constant re-try for ignition after a flame failure.

When the disconnect is in the "ON" position ①, power is applied through the blower door interlock switch ② to the control line voltage input terminal ⑤ and out of the control to the primary side of the control transformer "XFMR" ⑥. The low voltage side of the transformer supplies 24 volts to the control through terminals "TH" and "TR" ②⑨. Control terminal "R" ②⑨ supplies 24 volts to the "R" terminal on the room thermostat.

24 Volt Power On

When 24 volt power is present at terminals TH and TR ②⑨ on the furnace control, no relays are activated. The **K 1** cooling relay ②⑧ will only be energized when power is applied to the "G" terminal ②⑨ on the furnace control. If a limit trips, the indoor fan motor ③ will run at the heating speed ③.

Typical Start Up

On a call for heat, the indoor thermostat completes the circuit from the "R" terminal to "W" ②⑨ then to the common contact of the combustion air pressure switch ①⑦ through the limit switch and rollout fuse link ①⑨, and thus to relay **K 2** and **K 7** ①⑦. (On downflow and horizontal models, an additional limit switch and fuse link may be used.) When relay **K 2** is energized ①⑦, its **K 2A** contacts close ①⑥, providing a holding circuit for itself. Contacts **K 7** also close ⑦, and start the Induced Draft Motor ⑩.

When the Induced Draft blower ⑩ comes up to speed, the combustion pressure switch ①⑦ trips, connecting power, (through the flame switch radiant sensor bi-metal ②①), to relays **K 4** and **K 6** ②①②①.

When relay **K 6** is energized, its contacts ⑧ connect line power to the ignitor. Also, normally open contacts **K 4B** close ②⑥, bypassing resistor EQSO ②④ (Electrical Quick Shut Off) and allowing the redundant gas valve ②⑥ to pull in. As the ignitor heats up, its radiant energy is sensed by the flame switch radiant sensor's bi-metal which will cause its contacts to trip. When the contacts trip, relays **K 6** and **K 4** ②①②① are de-energized allowing contacts **K 6** to open, de-energizing the ignitor ⑧. At the same time, normally open contacts **K 4B** open ②⑥, but the redundant valve is held open due to the EQSO resistor in series with the RV coil. The flame switch radiant sensor bi-metal closes a circuit to the normally open hot side ②①, energizing the main valve ②② and the **K 3** fan time delay relay circuit.

Thus gas flows and ignition takes place. The fan time delay circuit starts the time delay to start the indoor blower (normally a 45 second delay), then warm air circulation begins.

Typical Shut Down

When the thermostat is satisfied and power is removed from the "W" terminal ②⑨, the gas valve is de-energized. The time delay circuit keeps contacts **K 3** ③ closed for approximately 90 seconds to allow all of the heat to be extracted from the furnace. When the **K 3** contacts open, the indoor blower stops, unless constant fan has been selected.

Circuit Safety Features

The circuit is arranged to prove that the combustion blower ⑩ is operating. The pressure switch ①⑦ must always start in the normally closed position ①⑥ and then transfer to an open position ①⑧, proving that the switch is functioning. This also proves that the Induced Draft Motor is circulating air through the furnace.

The flame switch radiant sensor bi-metal ②① controls relay **K 4** ②①. Its contacts maintain safe operation of the gas valve. If the flame switch is open at the start of a cycle, the redundant valve ②⑥ cannot open due to the normally open contacts of relay **K 4B** ②⑥. Resistor EQSO ②④ provides current flow enough to hold the valve open, but will not allow it to open from a closed position).

If the limit switch ①⑨ opens, due to high heat exchanger temperature, relay **K 3** ②② will power the indoor blower on the selected heating speed.

A momentary power interruption will cause relay **K 2** to de-energize ①⑦ and break its holding circuit ①⑥. This will cause the furnace to restart only after the pressure switch closes again ①⑥, proving its operation.

A momentary gas interruption will cause the flame switch radiant sensor bi-metal to start cooling. In about 30 seconds, the switch will transfer to the cold position ②①, closing the main valve ②⑦ and stopping gas flow. Relay **K 6** and **K 4** will be energized, and a new start up cycle will begin.

Note: This furnace has been certified to allow unburned gas to flow for a stated "flame failure response time" and then be ignited without excessive flame roll-out.

The roll-out fuse link will open the circuit and stop gas flow if it is overheated due to a flame roll-out. (On downflow and horizontal models, an additional limit switch and fuse link may be used.) As an example, this may occur with a blocked flue. At this time, the indoor blower will be powered on the selected **heating speed**.

Wiring Schematic

Version 3 Radiant Sense Control

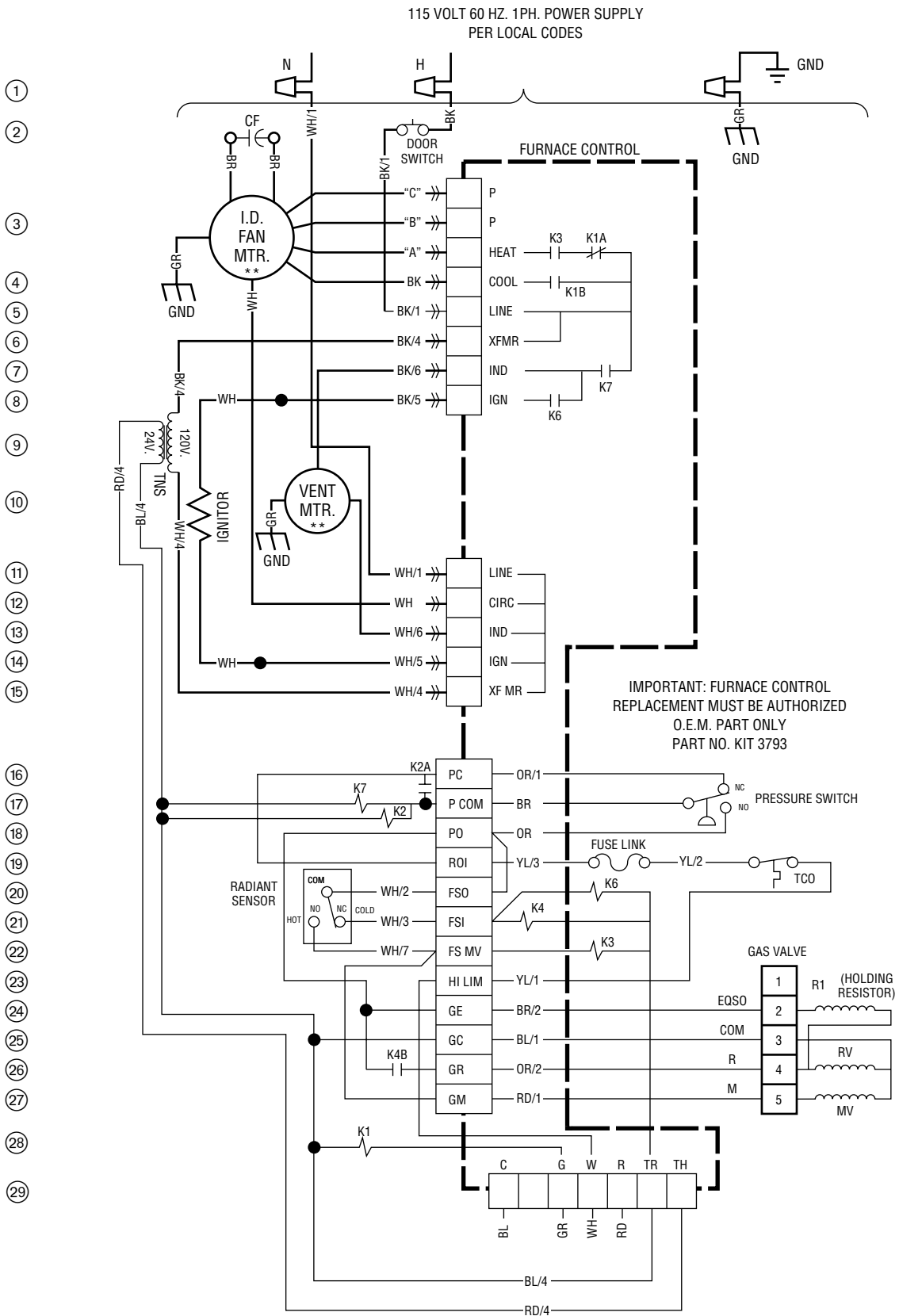

White-Rodgers 50A52-100/101/102 Sequence of Operation

Version 4 (E93, E1, E2, E3) 5 Relays, 3 Wire Flame Switch Radiant Sensor

This control contains a micro-processor allowing a single re-try upon ignition failure or loss of flame. It is a "two try" board. It also provides an **automatic reset after three hours** following a system lock-out condition.

When the disconnect is in the "ON" position ①, power is applied through the blower door interlock switch ② to the control line voltage input terminal ⑤ and out of the control to the primary side of the control transformer "XFMR." ⑥ The low voltage side of the transformer ⑨ supplies 24 volts to the control through terminals "TH" and "TR." ⑳ Control terminal "R" ㉑ supplies 24 volts to the "R" terminal on the room thermostat.

24 Volt Power On

When 24 volt power is present at terminals TH and TR ㉑ on the furnace control, no relays are activated. In this model, the K1 indoor fan cooling relay will only be energized when power is applied to the "G" terminal ㉒ on the furnace control. In the event of a limit trip ⑲, the indoor fan motor ③ will run at the chosen **heating speed**.

Typical Start Up

On a call for heat, the indoor thermostat completes the circuit from the "R" terminal to "W" to the common contact of the combustion air pressure switch ⑰ through the limit switch and roll-out fuse link ⑱. (On downflow and horizontal models, an additional limit switch and fuse link may be used.) It also starts the micro-processor.

As the control micro-processor is energized, the **K 3** normally open relay contacts closes ⑦, and starts the Induced Draft Motor ⑩. When the Induced Draft Motor comes up to speed, the combustion air pressure switch ⑰ trips supplying power through the normally closed (cold) radiant sensor contacts ㉑ to the redundant ㉒ and EQSO gas valve terminals ㉔. The hot surface ignitor ⑩ is also energized when the **K 4** relay contacts ⑧ close. The flame switch radiant sensor normally closed (cold) contacts ㉑ will transfer to the hot position when sufficient radiant energy is sensed.

The microprocessor ㉓ initiates a timing cycle for ignition. After 17 seconds (see note), the normally open **K 5** contacts ㉗ (main gas valve) will close. The control will allow the ignitor to remain on until a total of 90 seconds (see note) have passed. If at the end of 90 seconds (see note), the control has not sensed the flame switch radiant sensor bi-metal trip, it will lockout.

If the flame switch radiant sensor bi-metal has tripped normally within time allowed, the gas valve will be energized through **K 5** ㉗. Two things then happen, the 45 second indoor fan heat-on time delay will start and a 90 second flame proving cycle will be started.

After the gas valve has been energized for one second, the ignitor is de-energized.

Providing the furnace fires normally, the cycle will continue until a normal shut-down.

If the flame switch radiant sensor bi-metal resets to the normally closed (cold) position ㉑, indicating no flame

is present, within the 90 second flame proving time, one re-try will be initiated after a 60 second purge by the combustion blower. If this re-try fails, the control will lock out.

After the furnace is in normal operation for more than 90 seconds, any fault causing a burner shut-down will be followed by two tries for re-ignition. This is called a recycle.

Typical Shut Down

When the thermostat is satisfied and power is removed from the "W" terminal ㉑, the gas valve is de-energized. The indoor fan time delay circuit keeps contacts **K 2** ③ closed for approximately 90 seconds to allow all of the heat to be extracted from the furnace. When the contacts open, the indoor blower stops, unless constant fan was selected.

Circuit Safety Features

The circuit is arranged to prove that the combustion blower ⑩ is operating. The pressure switch normally open contacts ⑰ must always start in the normally open position and trip to a closed position, proving that the switch is functioning. This also proves that the Induced Draft Motor is circulating air through the furnace.

The flame switch radiant sensor bi-metal signals its tripped or "hot" position ㉑ to the micro-processor ㉓. This circuit maintains safe operation of the gas valve. If the flame switch radiant sensor bi-metal is "hot" at the start of a cycle, the redundant valve ㉒ cannot be powered since the normally closed contacts would be open. Resistor EQSO (Electrical Quick Shut Off) provides current flow enough to hold the redundant valve open, but will not allow it to open from a closed position ㉔.

If either limit device opens ⑲, (due to high heat exchanger temperature or roll-out), relay **K 2** ③ will power the indoor blower on the selected heating speed and relay **K 3** ⑦ will power the combustion blower.

In both of these cases, the indoor blower and the combustion blower will be powered until the limit re-sets. The combustion blower will then stop immediately but the indoor blower will continue with the normal blower shut-down sequence. E93 and E1 controls will then energize the ignitor and begin another ignition sequence. E2 controls will not energize the ignitor until the radiant sensor trips to the cold position.

A momentary power interruption will cause the micro-processor ㉓ to de-energize and break the holding circuit. This will cause the system to enable a re-start only after the pressure switch opens and then closes again, proving its operation ⑰.

A momentary gas interruption will cause the flame switch radiant sensor to start cooling. In about 30 seconds, the switch will transfer to the cold position ㉑, closing the main valve ㉗ and stopping gas flow. The normal ignition start-up cycle will begin if the thermostat is calling for heat.

Note: 50A52-101 (E93, E3) and 50A52-102 (E90, E4) have a minimum warm up time of 12 seconds and a maximum time of 30 seconds

Wiring Schematic

Version 4 Radiant Sense Control

115 VOLT 60 HZ. 1PH. POWER SUPPLY
PER LOCAL CODES

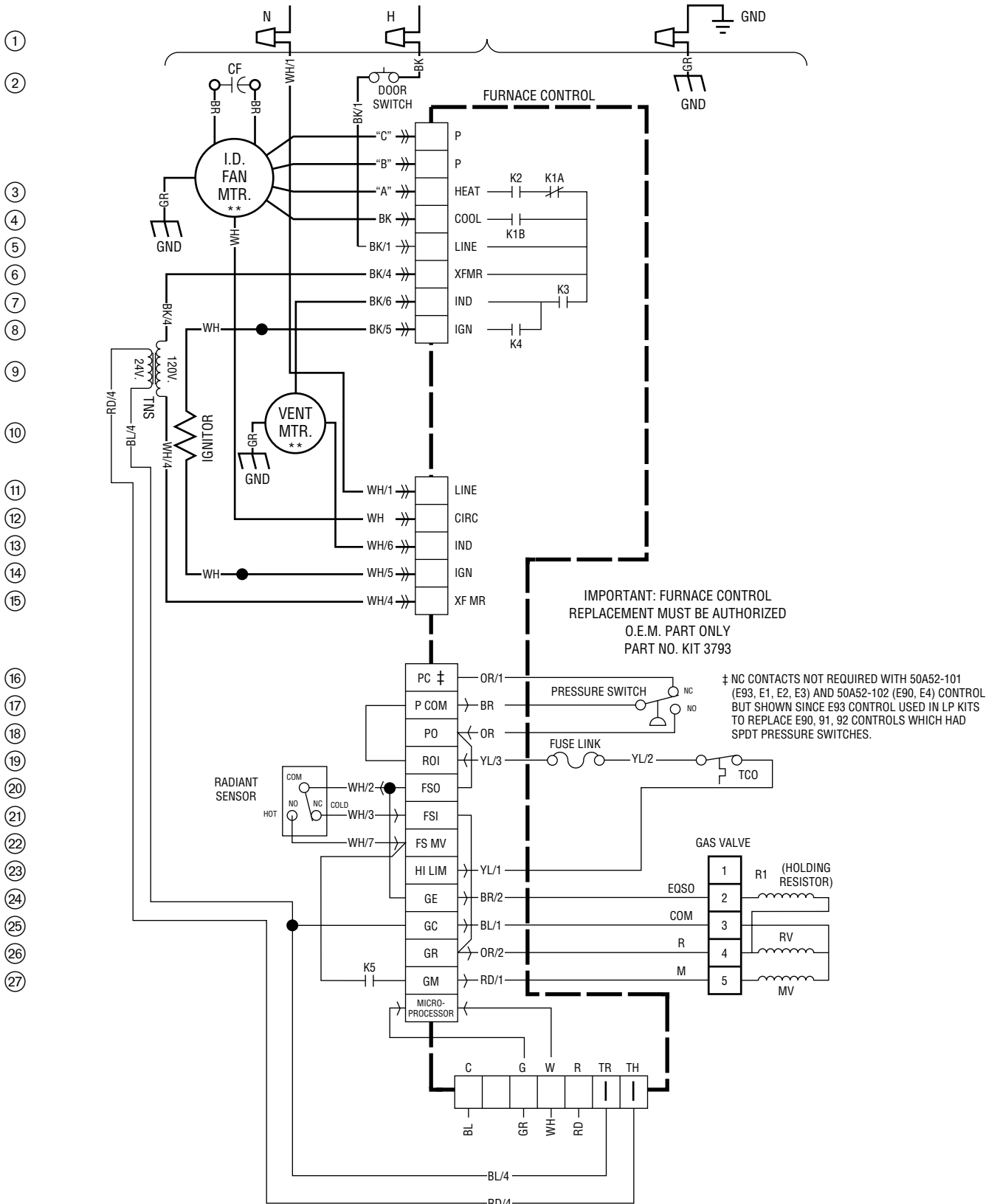

- ①
- ②
- ③
- ④
- ⑤
- ⑥
- ⑦
- ⑧
- ⑨
- ⑩
- ⑪
- ⑫
- ⑬
- ⑭
- ⑮
- ⑯
- ⑰
- ⑱
- ⑲
- ⑳
- ㉑
- ㉒
- ㉓
- ㉔
- ㉕
- ㉖
- ㉗

White-Rodgers Troubleshooting Procedures

Furnace Models 50A50 and 50A51

If the light on the module is on continuously, the fault is likely to be internal to the module. To make sure, interrupt line or 24 volt thermostat power for a few seconds and then restore. If internal fault is indicated again, and flame sensor is not shorted to ground, replace control. A flashing light indicates the problem is most likely in the external components or wiring. Proceed as follows:

Line voltage (120V AC) could be present on the surface of the ignitor, if the system is not correctly wired. Such voltage can cause serious injury or death.

The following steps must be performed before any troubleshooting begins:

1. Disconnect electric power to system at main fuse or circuit breaker.
2. Visually Inspect equipment for apparent damage. Check wiring for loose connections.
3. Check for proper grounding and reversed polarity.
 - A. Check continuity from B/C terminal on module to electrical service ground and connection at the furnace junction box. If ground connection is open, check module ground connection and the electrical service ground connection. Repair and retest
 - B. Re-connect electrical power to the system
 - C. Check for voltage between the line neutral terminal and furnace ground. If voltage exists, the main power supply lines are improperly connected to the furnace (REVERSED POLARITY). Again disconnect electric power to system, then reverse incoming supply leads to furnace. Repeat step.
 - D. Recheck system for proper operation.

If neither apparent damage, loose connection nor reversed polarity is the problem, proceed to troubleshooting or fault index chart that is suggested by the actual condition, see below.

⚠ CAUTION: If diagnostic indicator (LED) shows five (5) flashes, turn off gas supply at source before disconnecting electrical power. Failure to do so may result in personal injury or fire.

Furnace Model 50A52

The following steps must be performed before any troubleshooting begins on any Radiant Sense Furnace model:

1. Disconnect electric power to system at main fuse or circuit breaker.
2. Visually inspect equipment for apparent damage. Check wiring for loose connections.
3. Check for proper unit grounding.
4. Check for broken ignitor.
5. Visually inspect pressure switch hose for cracks, splits and tight connection to the barbed fitting.

6. Inspect vent pipe for signs of corrosion or condensation.
7. Re-connect power to system.
8. Check system operation.

If problem is found, refer to the fault index chart for that particular problem or proceed directly to the troubleshooting chart.

50A50 Fault Chart

Probable Fault	Chart	Page
No manual fan	1A-1K	51
Power supply and voltage	1C-1G	51
No fan at cooling speed	2A-2L	52
No induced draft motor	3A-3H	53
LED flashing slowly	3B-3C	53
LED on continuously	1G	51
LED flashing 3 X without inducer	3E	53
LED flashing 3 X with inducer	3I-3O	53
Ignitor does not glow	4A-4D	54
Burner does not stay lit	4E-4N	54
Gas supply problem	4F-4K	54
No outlet pressure	4H-4J	54
Gas valve does not energize	4L-4N	54
Flame sensor fault	5A-5P	55
Burner ground	5K	55
Polarity check	5L-5M	55
Ignitor stays on after burner ignition	5B-5C	55

50A51 Fault Chart

Probable Fault	Chart	Page
No manual fan	1A	56
Power supply and voltage	1B	56
No low heat fan	2A	57
No induced draft motor	2B	57
LED flashing slowly	2C	57
LED on continuously	2D	57
LED flashing 3 X without inducer	2E	57
LED flashing 3 X with inducer	3A	58
Ignitor does not glow	3B	58
Gas supply problem	3C	58
No outlet pressure	3D	58
Gas valve does not energize	3E	58
Flame sensor fault	4A	59
Burner ground	4B	59
Polaritycheck	4C	59
Ignitor stays on after burner ignition	4D	59
Indoor does not shift to high speed	5A	60
Gas valve does not switch to high heat	5B	60
Indoor blower does not switch to high speed	5C	60

50A52 Fault Chart

Probable Fault	Chart	Page
No cooling fan operation	1A	61
No 24 volt secondary voltage	1B	61
Induced Draft Motor inoperative	2A	62
Defective pressure switch	2B	62
Ignitor won't glow	2B-3A	62
Gas valve does not open	3B	63
Radiant flame sensor	4A	64
No heating fan operation	4B	64

50A50 Flow Chart 1

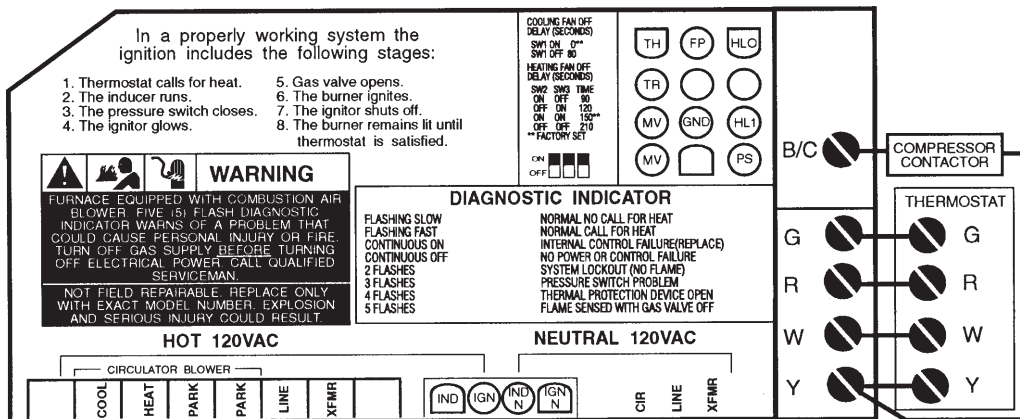
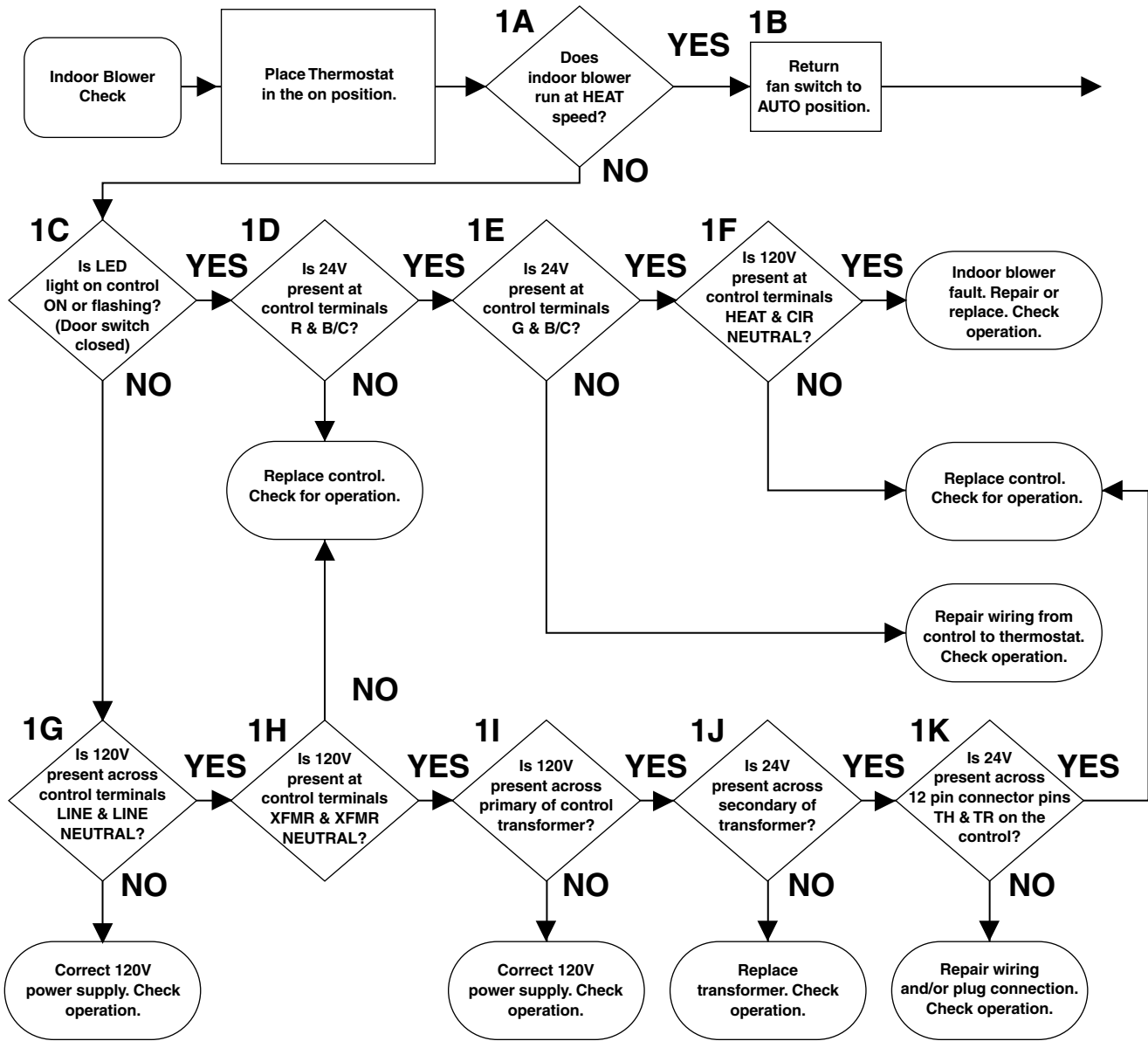

CAUTION: If diagnostic indicator (LED) shows five (5) flashes, turn off gas supply at source before disconnecting electrical power. Failure to do so may result in personal injury or fire.

Note: Check diagnostic LED light flash rate through view port in blower door before removing blower door!

50A50 Flow Chart 2

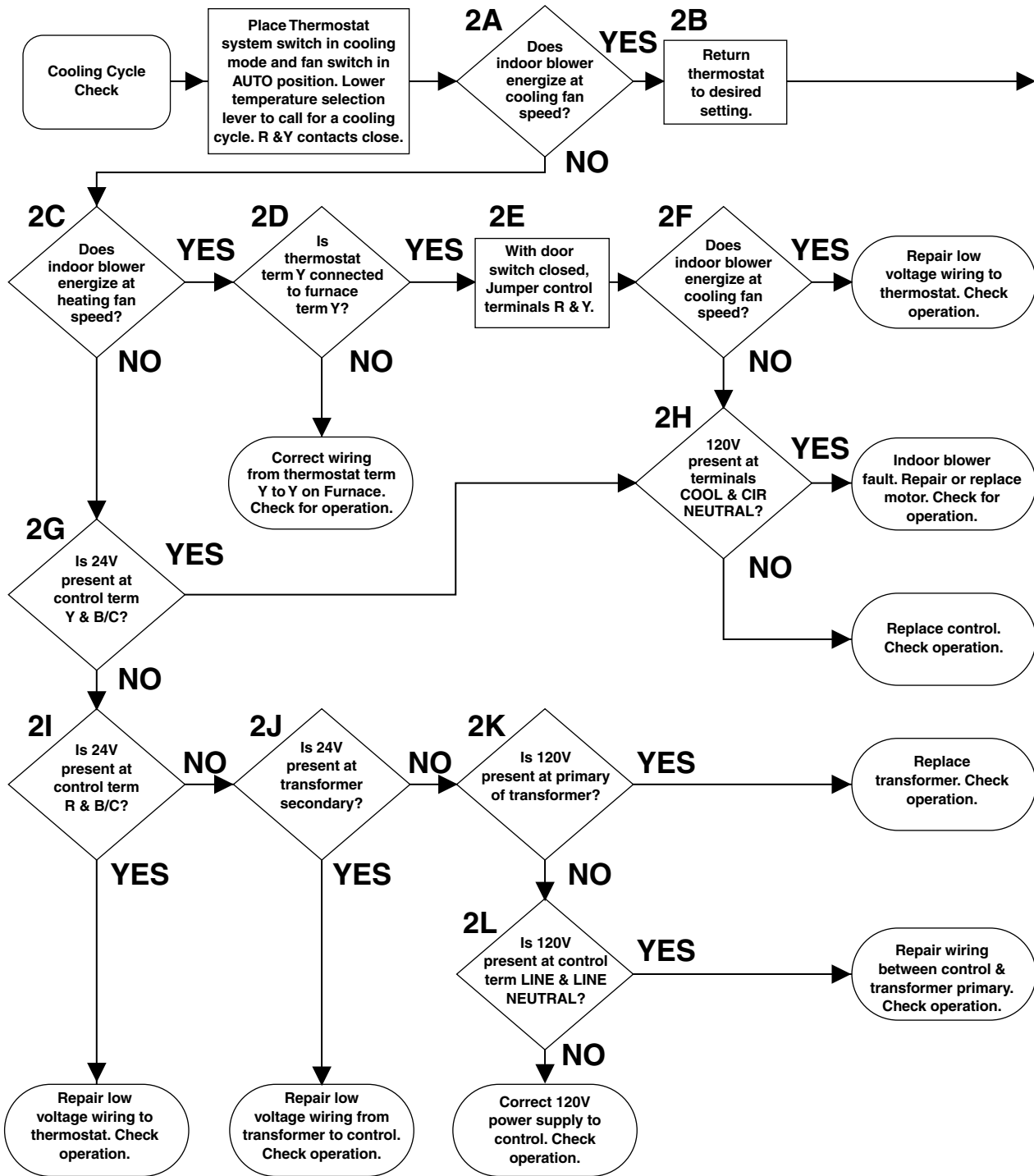

CAUTION: If diagnostic indicator (LED) shows five (5) flashes, turn off gas supply at source before disconnecting electrical power. Failure to do so may result in personal injury or fire.

Note: Check diagnostic LED light flash rate through view port in blower door before removing blower door!

50A50 Flow Chart 3

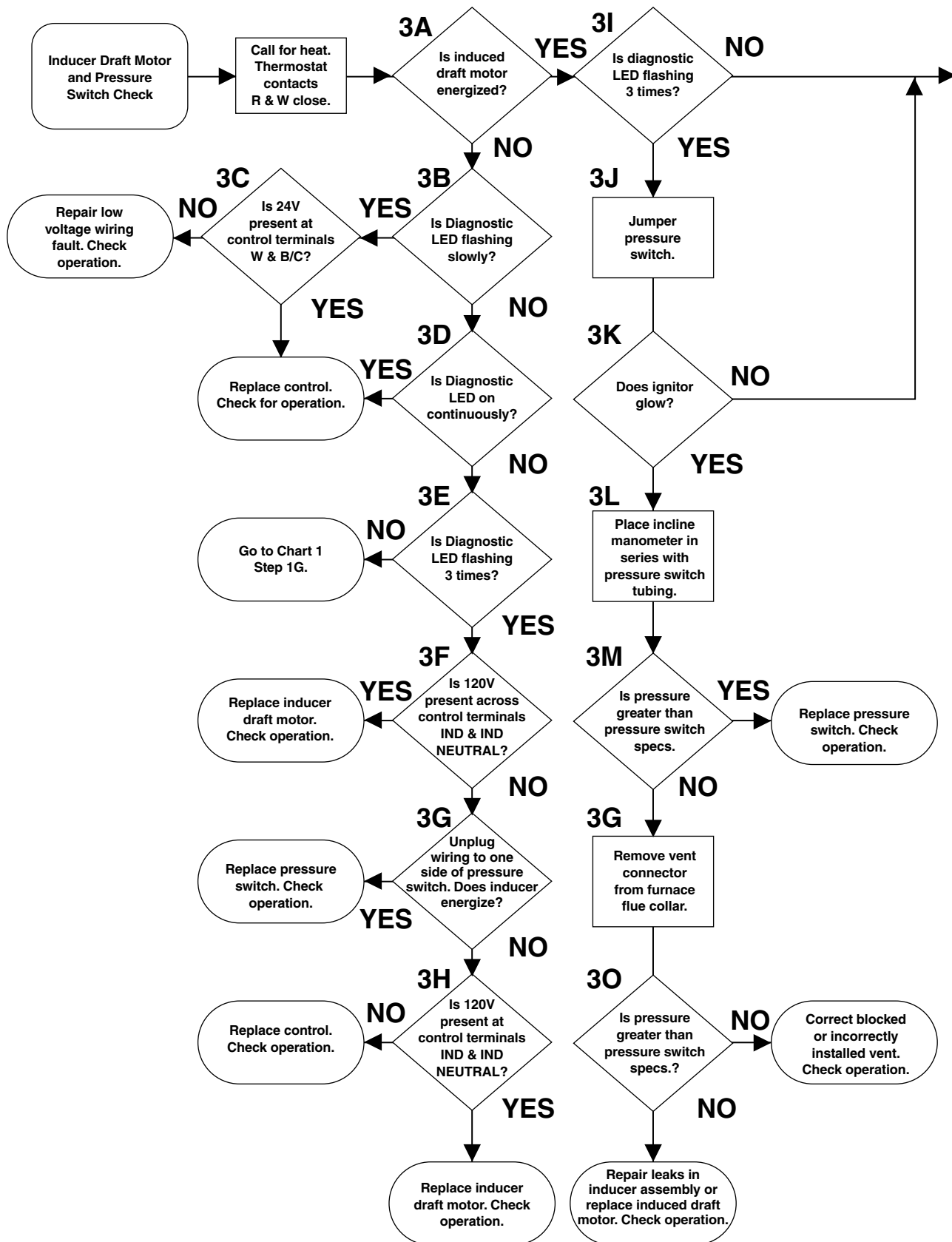

CAUTION: If diagnostic indicator (LED) shows five (5) flashes, turn off gas supply at source before disconnecting electrical power. Failure to do so may result in personal injury or fire.

Note: Check diagnostic LED light flash rate through view port in blower door before removing blower door!

50A50 Flow Chart 4

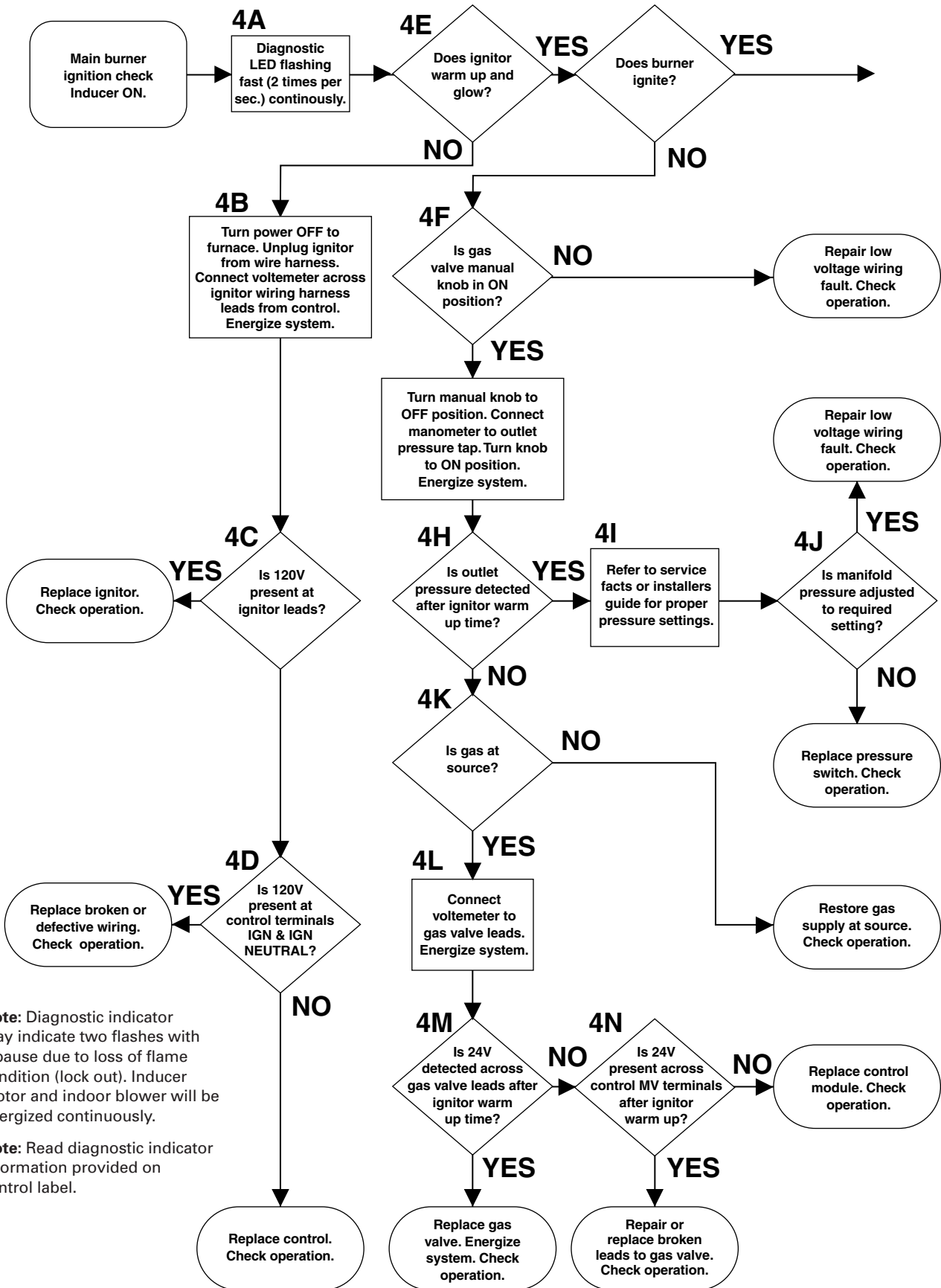

Note: Diagnostic indicator may indicate two flashes with a pause due to loss of flame condition (lock out). Inducer motor and indoor blower will be energized continuously.

Note: Read diagnostic indicator information provided on control label.

CAUTION: If diagnostic indicator (LED) shows five (5) flashes, turn off gas supply at source before disconnecting electrical power. Failure to do so may result in personal injury or fire.

Note: Check diagnostic LED light flash rate through view port in blower door before removing blower door!

50A50 Flow Chart 5

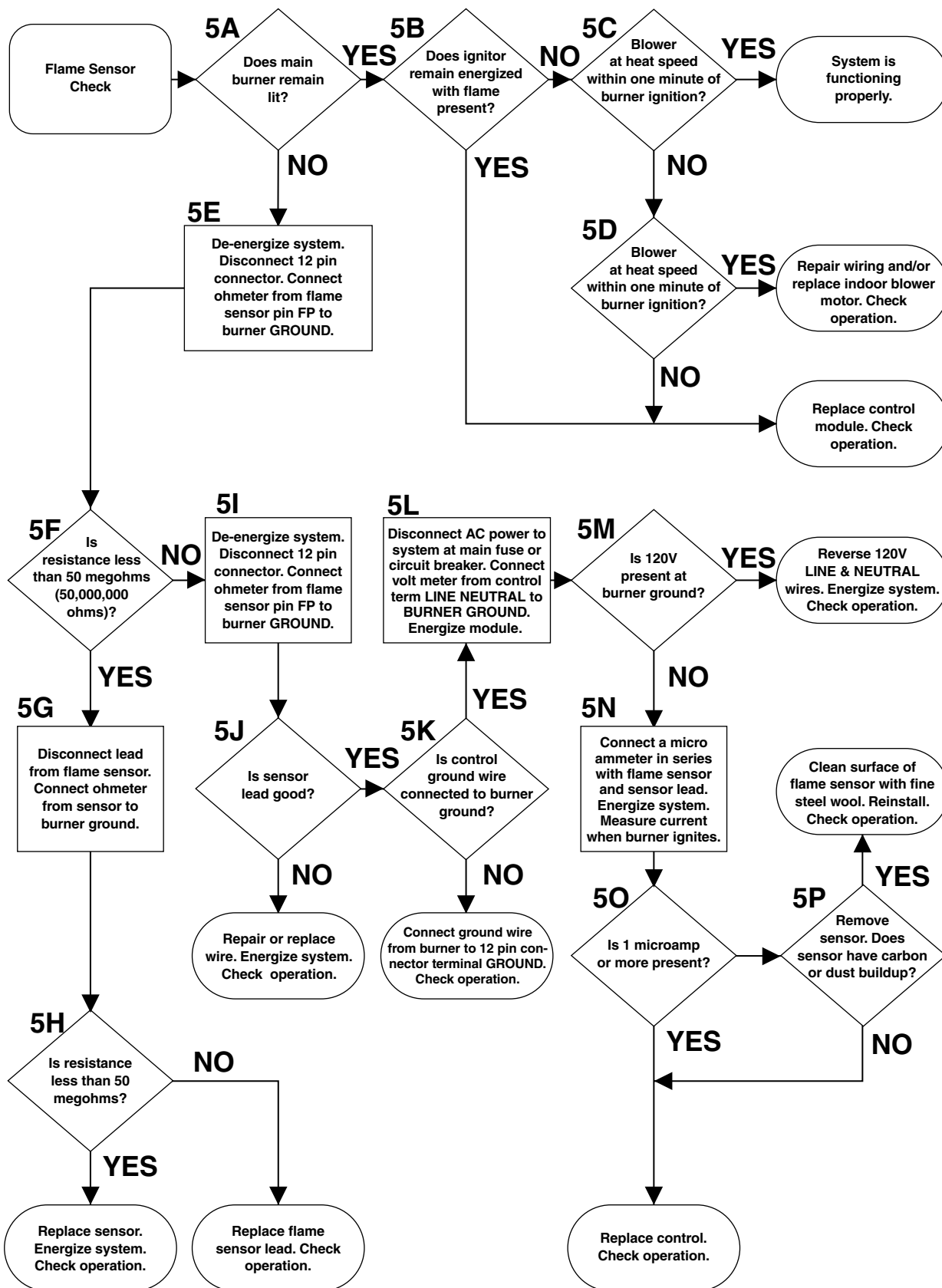

CAUTION: If diagnostic indicator (LED) shows five (5) flashes, turn off gas supply at source before disconnecting electrical power. Failure to do so may result in personal injury or fire.

Note: Check diagnostic LED light flash rate through view port in blower door before removing blower door!

50A51 Flow Chart 1

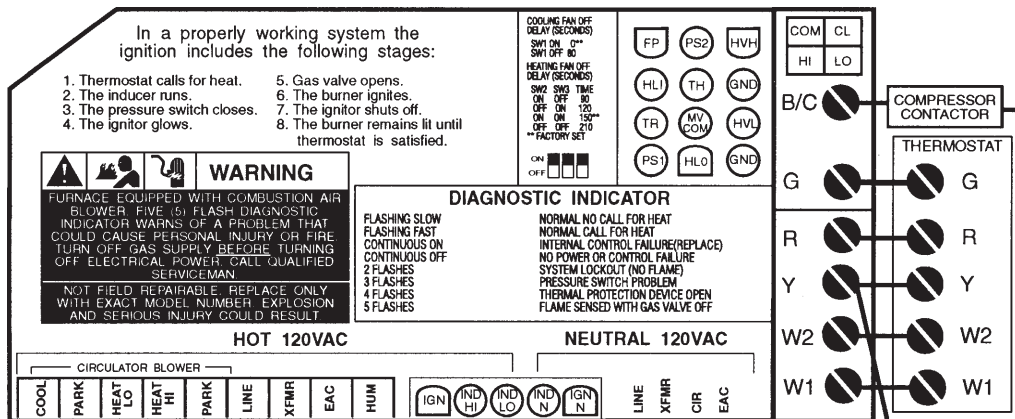
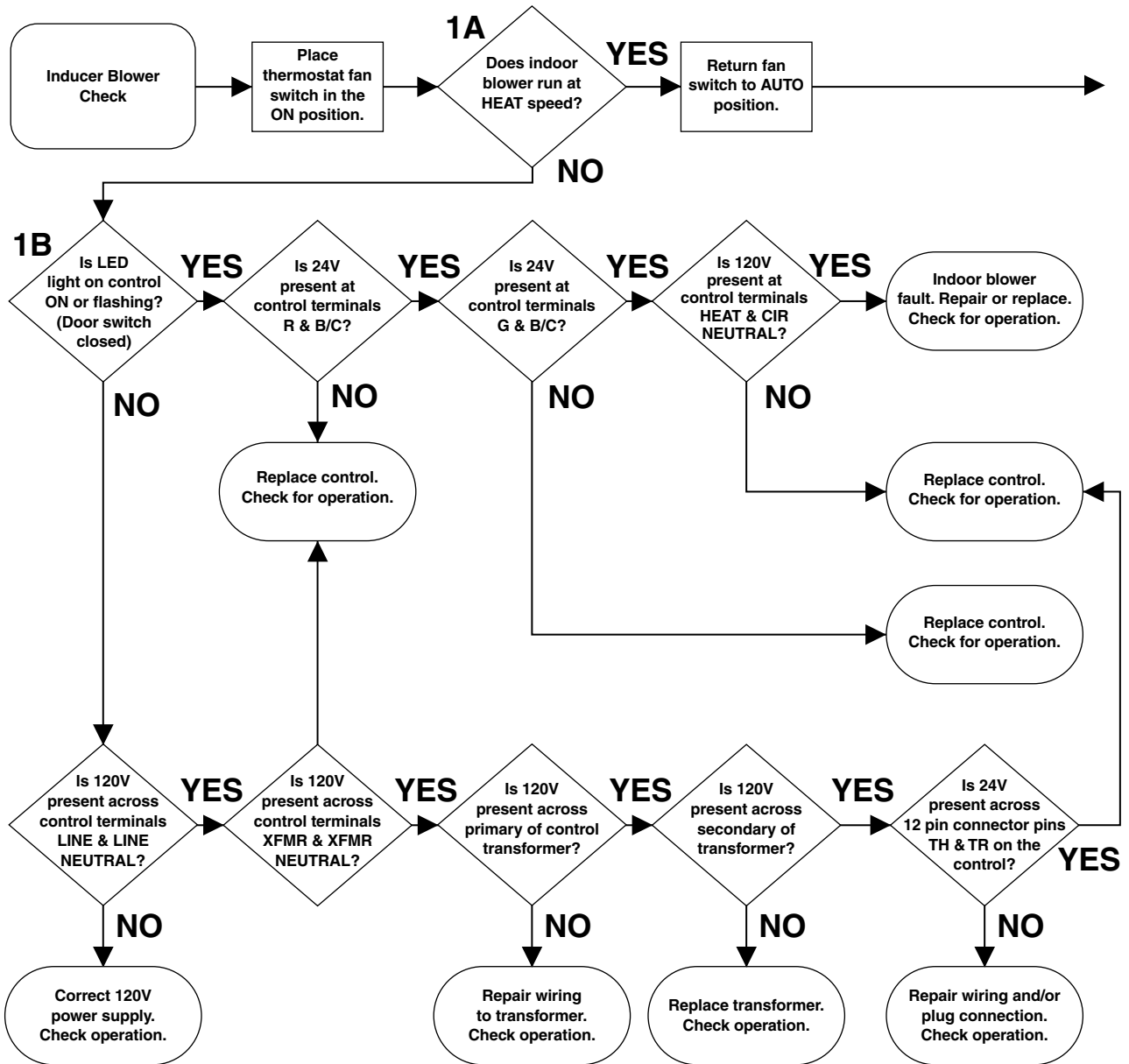

CAUTION: If diagnostic indicator (LED) shows five (5) flashes, turn off gas supply at source before disconnecting electrical power. Failure to do so may result in personal injury or fire.

Note: Check diagnostic LED light flash rate through view port in blower door before removing blower door!

50A51 Flow Chart 2

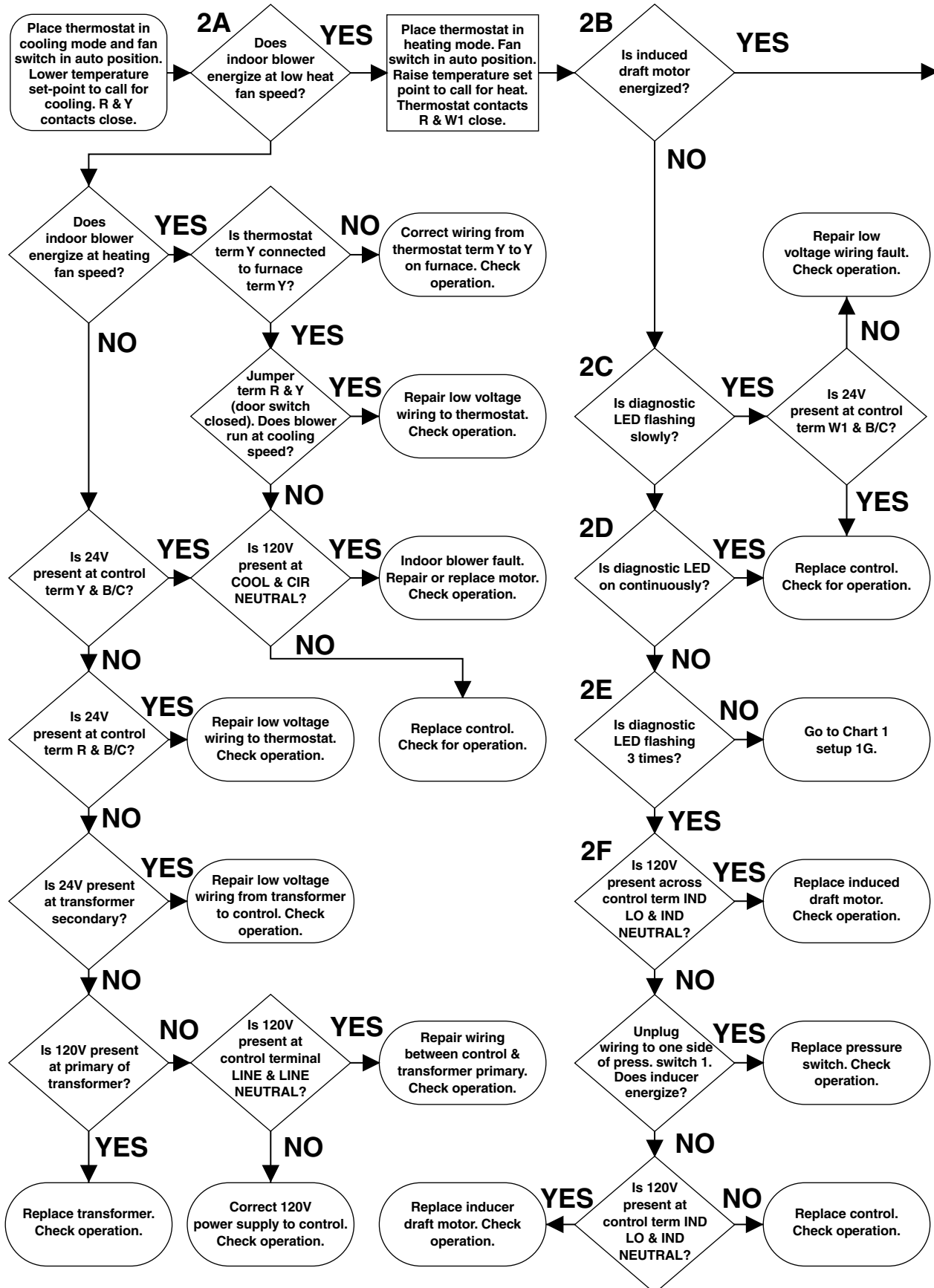

CAUTION: If diagnostic indicator (LED) shows five (5) flashes, turn off gas supply at source before disconnecting electrical power. Failure to do so may result in personal injury or fire.

Note: Check diagnostic LED light flash rate through view port in blower door before removing blower door!

50A51 Flow Chart 3

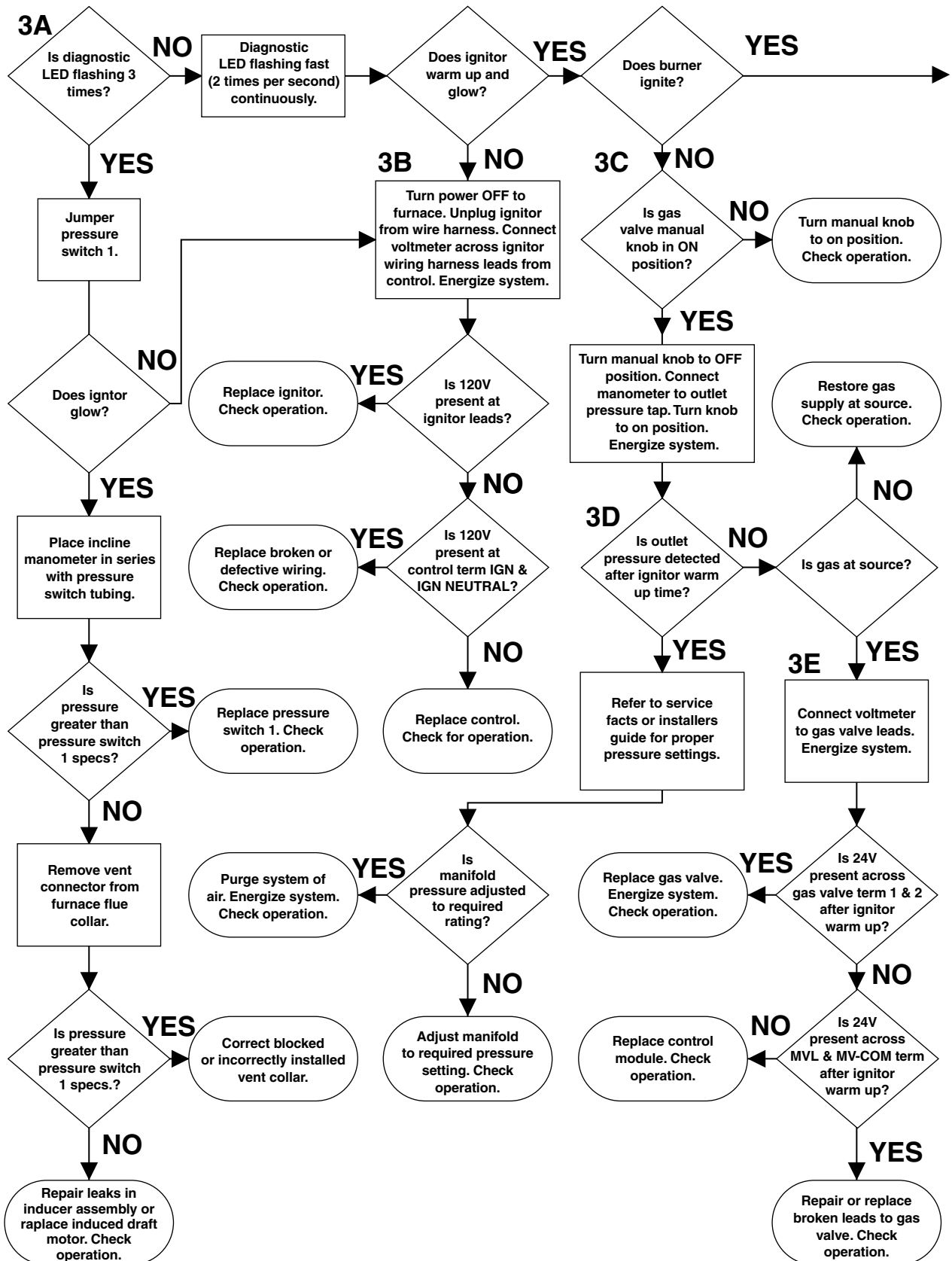

CAUTION: If diagnostic indicator (LED) shows five (5) flashes, turn off gas supply at source before disconnecting electrical power. Failure to do so may result in personal injury or fire.

Note: Check diagnostic LED light flash rate through view port in blower door before removing blower door!

50A51 Flow Chart 4

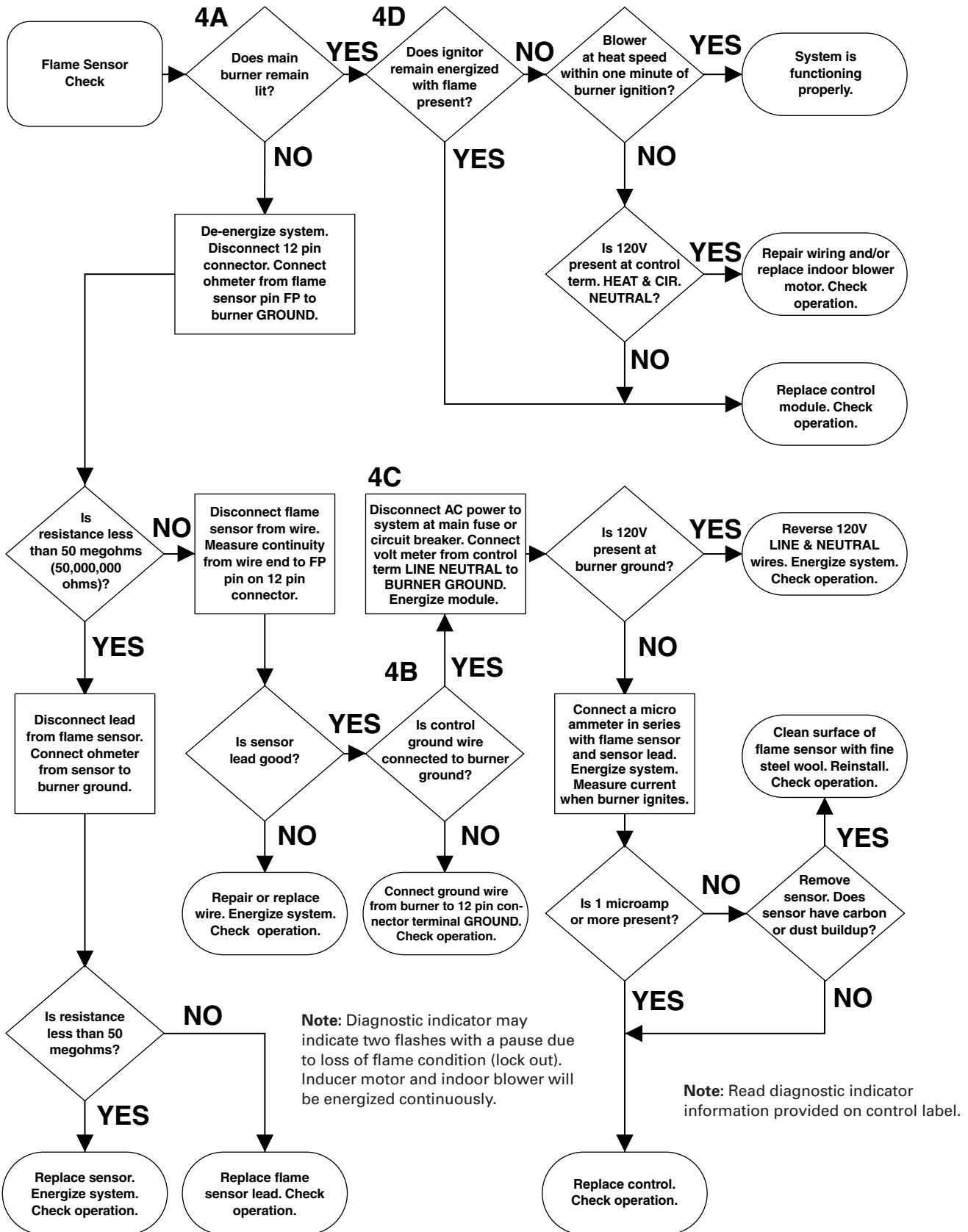

CAUTION: If diagnostic indicator (LED) shows five (5) flashes, turn off gas supply at source before disconnecting electrical power. Failure to do so may result in personal injury or fire.

Note: Check diagnostic LED light flash rate through view port in blower door before removing blower door!

50A51 Flow Chart 5

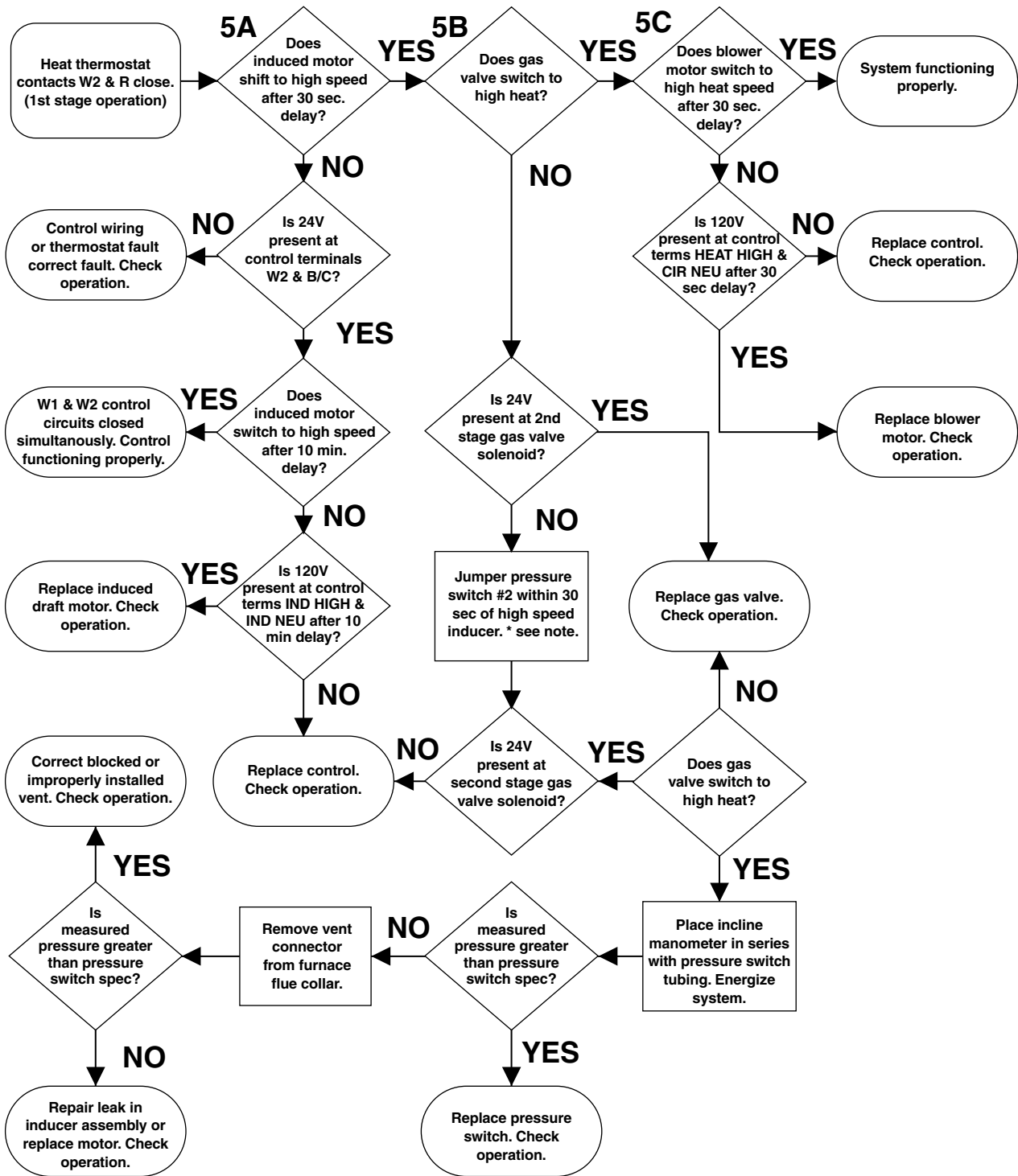

CAUTION: If diagnostic indicator (LED) shows five (5) flashes, turn off gas supply at source before disconnecting electrical power. Failure to do so may result in personal injury or fire.

Note: Check diagnostic LED light flash rate through view port in blower door before removing blower door!

Note: If pressure switch 2 does not close within 30 seconds of high speed inducer. The system will shut down as if the call for heat were removed. A 3 minute delay will occur before recycle will begin. LED will flash 3 times until PS-2 closes or first stage is satisfied.

50A52 Flow Chart 1

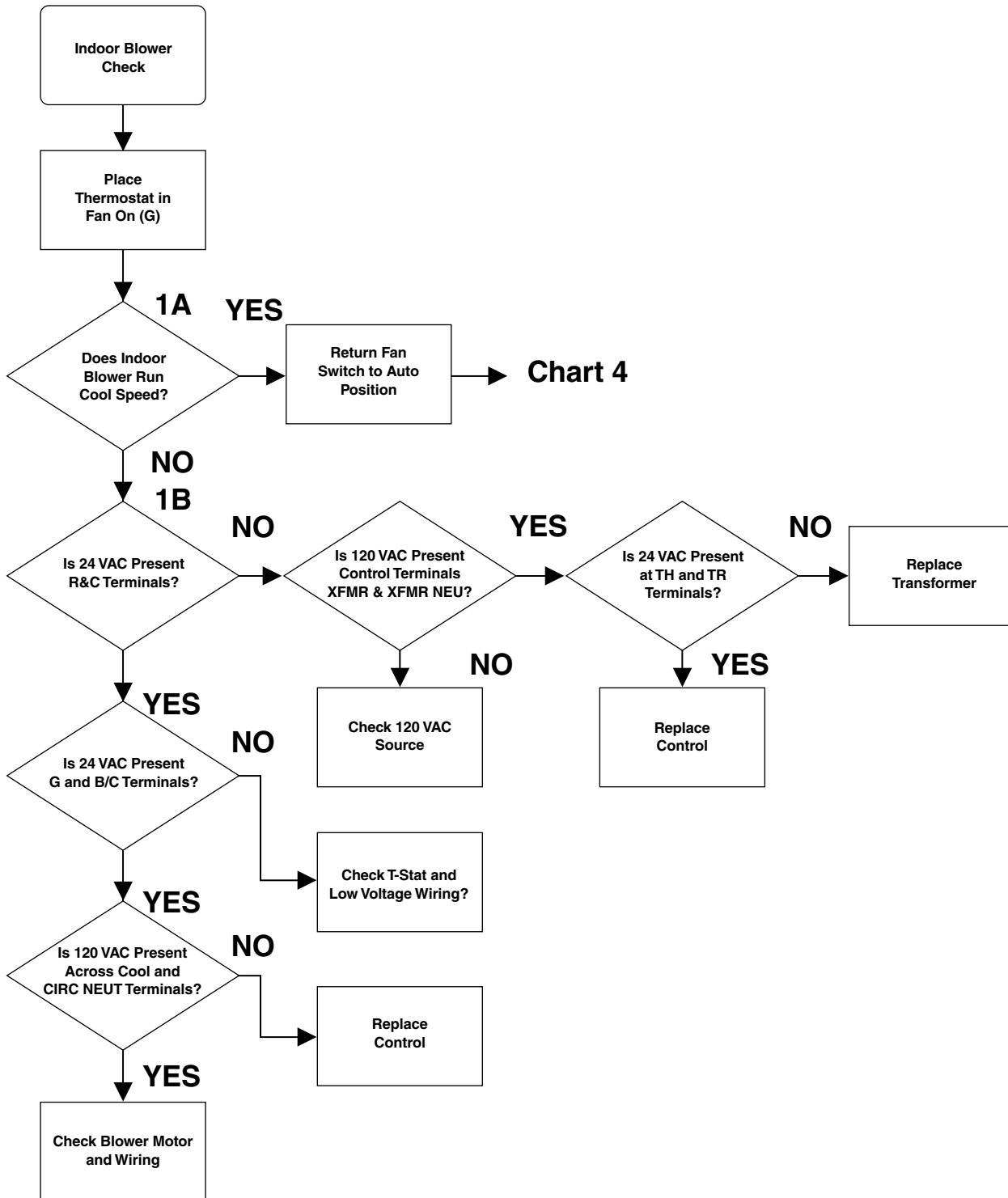

50A52 Flow Chart 2

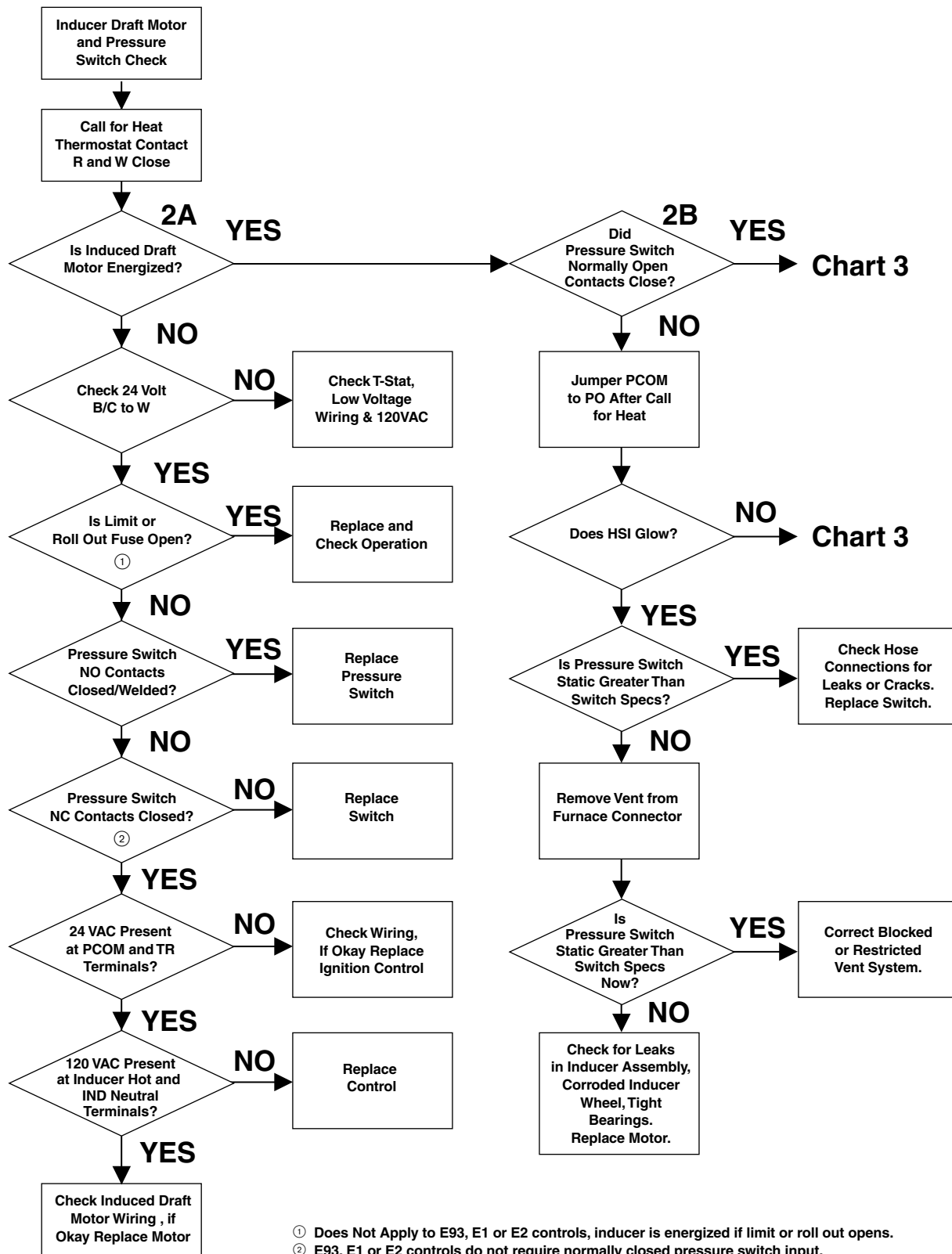

50A52 Flow Chart 3

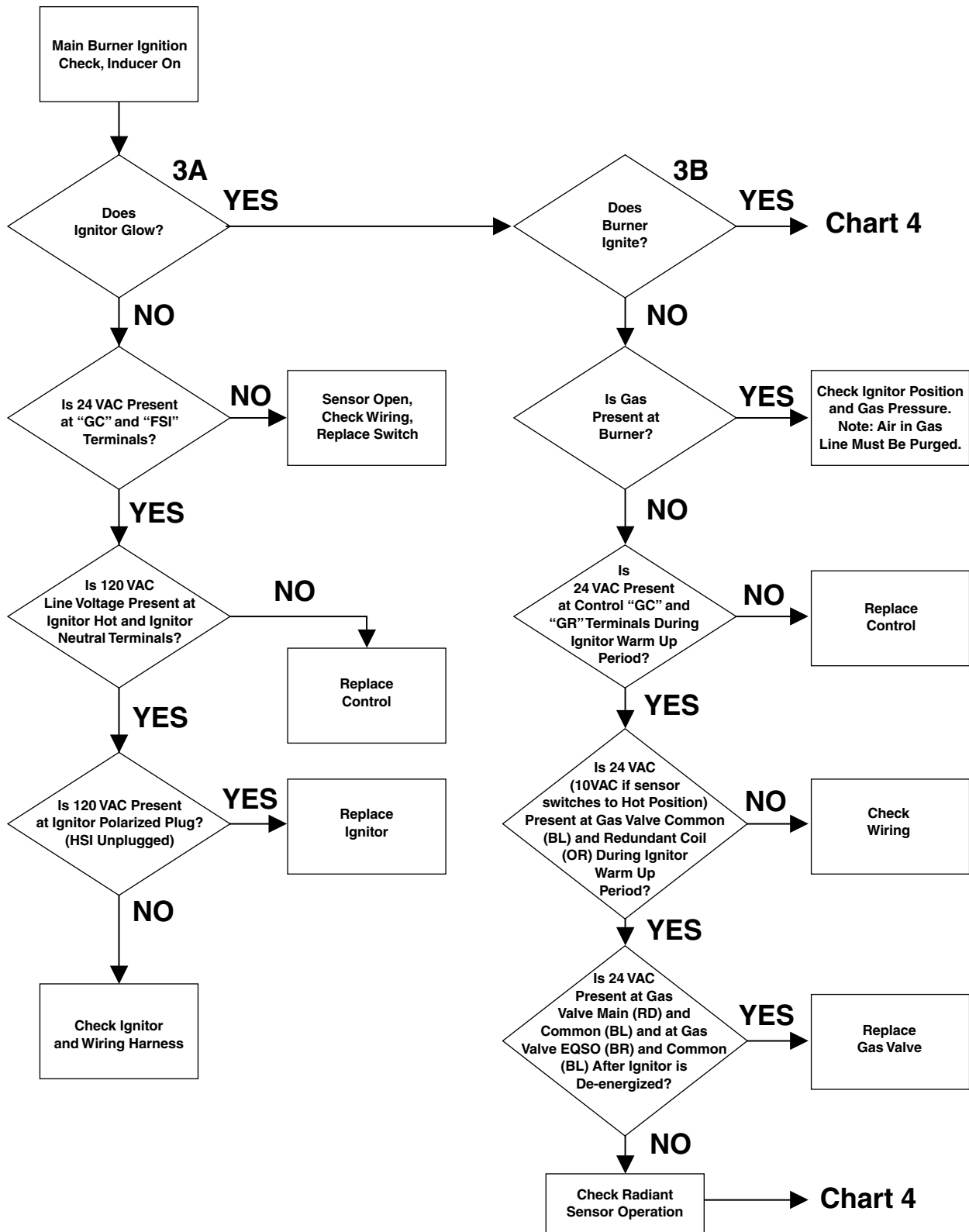

50A52 Flow Chart 4

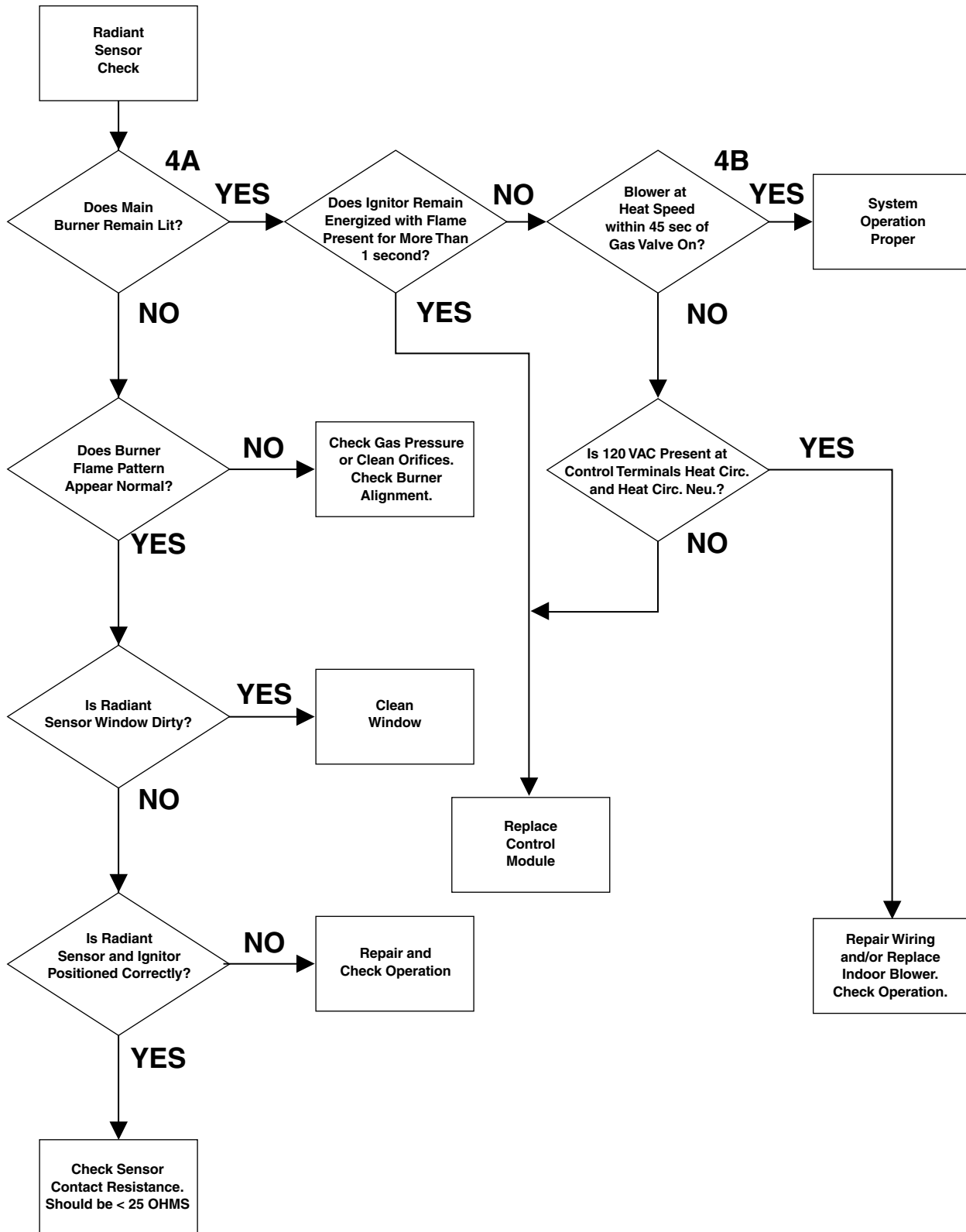

Legend – System Wiring

- 24 V. Factory Wiring
 - LINE V. Factory Wiring
 - 24 V. Factory Wiring
 - LINE V. Factory Wiring
 - Earth Ground
 - Chassis Ground
 - Junction
 - Wire Nut or Connection
 - Coil
 - Capacitor
 - Transformer
 - Connector
 - Press. Actuated Switch
 - Temp. Actuated Switch
 - Door Switch
 - Fusible Link
 - Terminal
 - Terminal Board
- Color of Wire
Black Wire With Blue Marker
BK / BL
Color of Marker
- | | | |
|-----------------|------------------|------------------|
| BK Black | OR Orange | YL Yellow |
| BL Blue | RD Red | GR Green |
| BR Brown | WH White | PR Purple |
- GV Gas Valve
 - CF Fan Capacitor
 - Gnd Ground
 - L Line
 - LVTB Low Voltage Terminal Board
 - MTR Motor
 - N Neutral
 - TCO High Temperature Limit Switch
 - TNS Transformer
 - NO Normally Open
 - NC Normally Closed
 - COM Common
 - GM Gas Valve Main
 - HLO High Limit Output
 - GE Gas Valve E.Q.S.O
 - ROI Roll Out Input
 - PO Pressure Swt. No
 - GC Gas Valve Common
 - FSO Flame Sensor Output
 - GR Gas Valve Redundant
 - PC Press.Swt. Nc
 - PCOM Press. Swt.Com
 - FSI Flame Sensor Input
 - TR 24V AC Trans. Com Side
 - TH 24V AC Trans. Hot Side
 - R Redundant
 - M Main
 - EQSO Electrical Quick Shut Off
 - ◆◆ Thermally Protected Internally

50A50 and 50A51 Models

Terminal		System Component Connection
Number	Type	
W	captive screw	low voltage thermostat W terminal 1st stage heat
W		low voltage thermostat W terminal 2nd stage heat
G		low voltage thermostat G terminal indoor fan
R		low voltage thermostat R terminal 24 VAC Hot
Y		low voltage thermostat Y terminal compressor contactor
B		24 VAC COMMON side of compressor contactor coil
MV	12-pin connector and harness	gas valve (both gas valve solenoids are connected in parallel)
MVL		gas valve 1st stage heat
MVH		gas valve 2nd stage heat
MVCOM		gas valve COMMON
TR		24v AC transformer (low voltage COMMON SIDE)
TH		24v AC transformer (low voltage HOT SIDE)
PS		pressure switch INPUT
PS2		pressure switch 2 INPUT
FP		flame sensor probe
PS1		pressure switch INPUT
HLI		high limit INPUT
HLO		high limit OUTPUT
GND		MUST BE RELIABLY GROUNDED TO CHASSIS
50A50 Only		4-pin connector and harness
IGN	ignitor HOT side	
IND N	inducer motor NEUTRAL side	
IGN N	ignitor NEUTRAL side	
50A51 Only	5-pin connector and harness	IND LO inducer motor HOT side low speed
IND HI		inducer motor HOT side high speed
IND N		inducer motor NEUTRAL side
IGN		ignitor HOT side
IGN N		ignitor NEUTRAL side
COOL	spade	indoor blower COOL SPEED terminal
PARK		unused indoor blower terminal
HEAT		indoor blower HEAT SPEED terminal
HEAT LO		indoor blower low HEAT SPEED terminal
HEAT HI		indoor blower high HEAT SPEED terminal
LINE		input voltage (120v AC) HOT SIDE
XFMR		24v AC transformer line voltage HOT SIDE
EAC		air cleaner HOT SIDE
HUM		humidifier HOT side
CIR N		indoor blower NEUTRAL terminal
LINE N		input voltage (120v AC) NEUTRAL SIDE
XFMR		24v AC transformer line voltage NEUTRAL SIDE
XFMR N		24v AC transformer line voltage NEUTRAL SIDE

continued

Legend – System Wiring

50A52 Model

Terminal		System Component Connection
Number	Type	
W G R Y	captive screw or 3/16" spade	low voltage thermostat W terminal (or equivalent) low voltage thermostat G terminal (or equivalent) low voltage thermostat R terminal (or equivalent) low voltage thermostat Y terminal (or equivalent) or 2nd wire from Y terminal goes to 24 VAC HOT side of compressor contactor coil
C		24-VAC COMMON side of compressor contactor coil
HLO ROI PC PCOM PO FSI FSO GE GR GM GC FSMV	12-pin connector and harness	high limit OUTPUT rollout INPUT pressure switch CLOSED contacts pressure switch COMMON pressure switch OPEN contacts flame switch INPUT flame switch OUTPUT gas valve – EQSO gas valve – REDUNDANT gas valve – MAIN gas valve – COMMON flame switch main valve
PARK (2 terminals) HEAT COOL LINE XFMR IND IGN LINE (neutral) CIRC (neutral) IND (neutral) IGN (neutral) XFMR	1/4" spade	unused circulator blower terminals circulator blower HEAT SPEED terminal circulator blower COOL SPEED terminal input voltage (120 VAC) HOT SIDE 24 VAC transformer line voltage HOT SIDE inducer HOT side ignitor HOT side line NEUTRAL side circulator blower NEUTRAL side inducer NEUTRAL side ignitor NEUTRAL side transformer NEUTRAL side
TR TH	3/16" spade	24 VAC transformer (low voltage COMMON side) 24 VAC transformer (low voltage HOT side)

