



Installation Sheet

Frame-mounted Tracer™ AH541 Controller

Order Numbers: BMTA000CAB00

The frame-mounted Tracer AH541 controllers can be used to replace controllers in existing equipment or mounted in new equipment or custom enclosures.

Warnings, Cautions, and Notices

Warnings, cautions, and notices are provided in appropriate places throughout this document:

⚠ WARNING: Indicates a potentially hazardous situation which, if not avoided, could result in death or serious injury.

⚠ CAUTION: Indicates a potentially hazardous situation which, if not avoided, may result in minor or moderate injury. It may also be used to alert against unsafe practices.

NOTICE: Indicates a situation that may result in equipment or property-damage only accidents.

NOTICE

Avoid Equipment Damage!

Install and use the controllers as specified by the manufacturer. Failure to do so may result in equipment damage.

Operating Environment Requirements

Make sure that the operating environment conforms to the specifications listed in [Table 1](#).

Table 1. Specifications

Temperature:	From -40°F to 158°F (-40°C to 70°C)
Humidity:	5–95% non-condensing
Power requirements:	21–27 Vac (24 Vac nominal)
Altitude:	6500 ft (2000 m)
Installation:	Category 3
Pollution:	Degree 2

Enclosure Requirements

Before installing the frame-mounted controller, ensure that the enclosure or mounting space meets the following minimum requirements:

- Minimum clearance (shown in the illustration below)
- 24 Vac dedicated power supply
- Compliance with National Electrical Code™ (NEC) and applicable local electrical codes for high-voltage power wiring to the enclosure

Figure 1. Minimum clearances

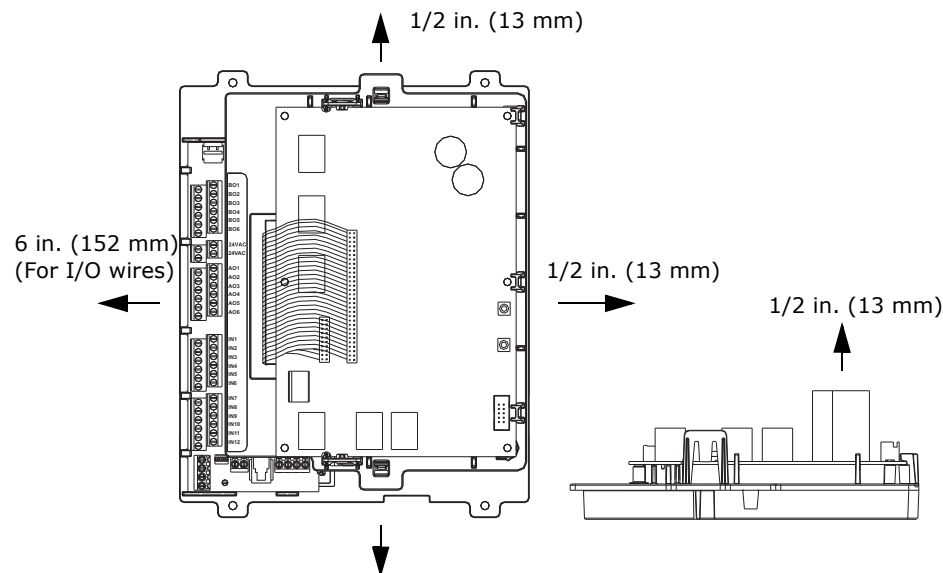

Installing the Termination Board

To install the termination board:

1. Remove the controller from its packaging and separate the top and bottom frames.
2. Using the bottom frame (with the termination board) as a template, mark the location of the four mounting holes and the grounding screw on the mounting surface.
3. Set aside the controller and then drill holes for #8 (4 mm) screws at the marked locations.
4. Drill a 1/8 inch diameter pilot hole for the supplied grounding screw.
5. Secure the controller to the mounting surface with the enclosed using #8 (4 mm) screws (not supplied) in the mounting holes.

Figure 2. Dimensions and mounting holes

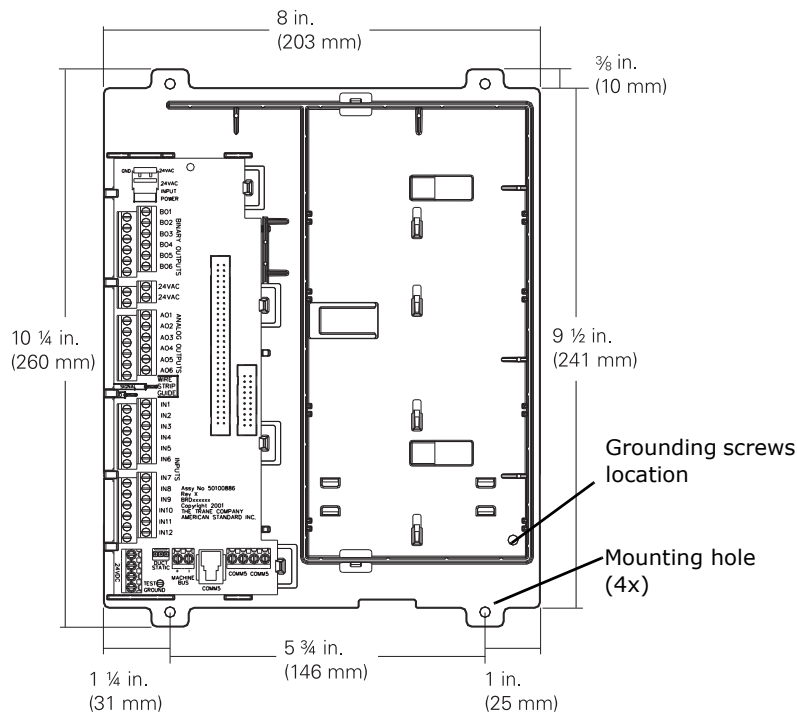

Installing the Main Circuit Board

The controller does not ship with the top plastic frame installed. The board can be kept in the office and programmed while the enclosure is mounted and wired. After programming has been completed, connect the circuit board to the termination board.

To begin, verify that the 24 Vac power cable is not connected to the termination board and then install the main circuit board as shown in [Figure 3, p. 5](#):

Frame-mounted Tracer™ AH541 Controller

Figure 3. Installing the main circuit boards

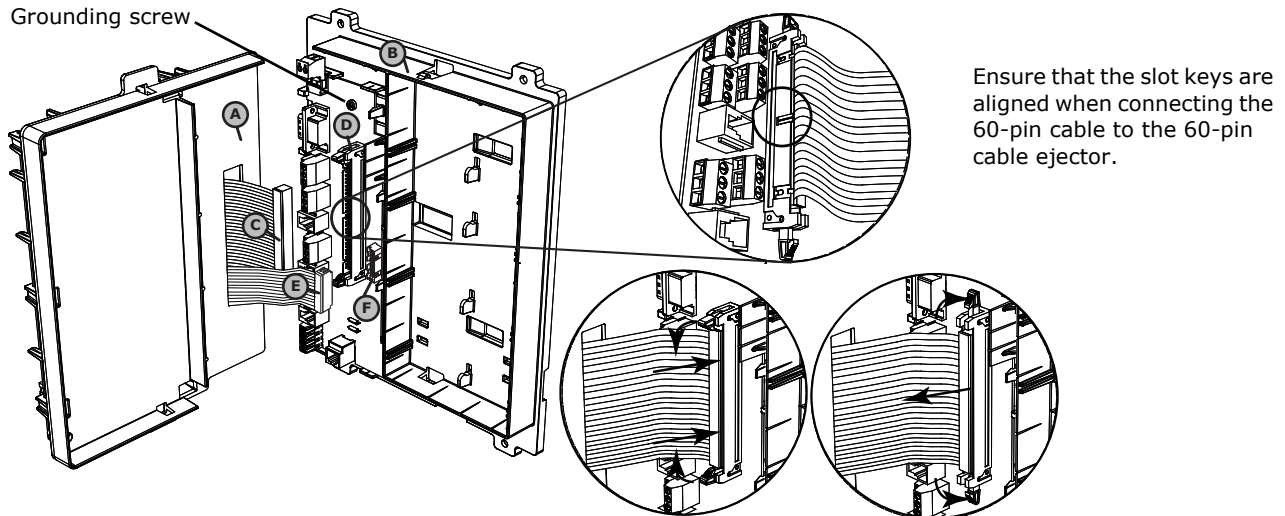

Important: The 60-pin cable ejector is designed to eject the 60-pin cable when disconnecting (refer to the lower right inset above).

1. Hold the top frame **(A)** at a 90° angle to the bottom frame **(B)**.
2. Connect the 60-pin cable **(C)** to the 60-pin cable ejector slot **(D)** by pressing down firmly on the cable until the ejector tabs collapse and snap over the ends of the cable. Then, connect the 20-pin cable **(E)** to the 20-pin slot **(F)**.
3. Align the snaps on the top frame **(G)** with the mounting locks on the bottom frame and then push the two frames together in the direction indicated by the arrows.

Note: You will hear a click when the frames connect. For controllers with an operator display, connect the operator display cable to the circuit board.

4. Install the supplied grounding screw (6-32 x 2 inch, thread-rolling screws) into the assembly and turn it into the sheet metal backing.

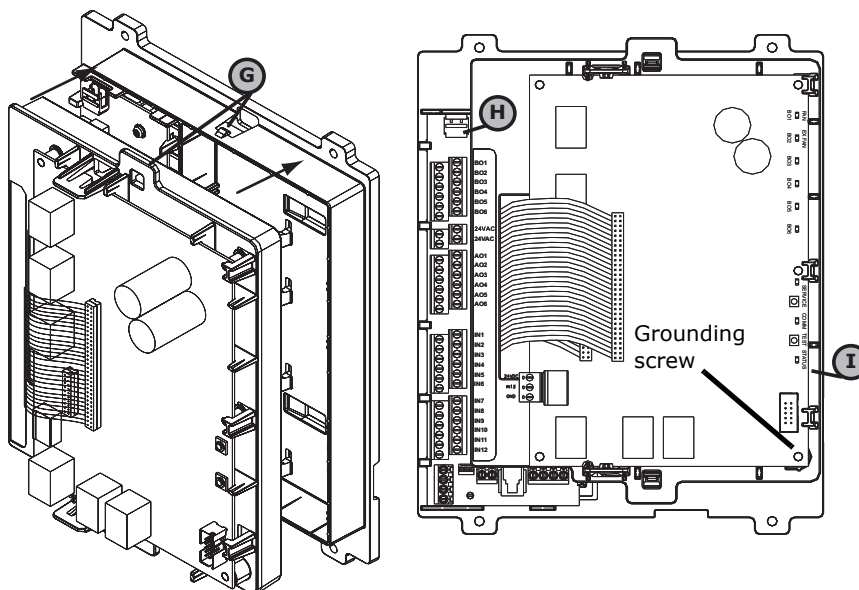

5. Locate the 24 Vac power connector on the termination board. Remove the mating plug with screw terminals.
6. Attach the 24 Vac power-supply cable to the screw terminals on the mating plug.
7. Connect the 24 Vac power cable to the termination board **(H)**. The green status LED will light **(I)**.

Tracer AH541 Declaration of CE Conformity

Manufacturer name: Trane
Manufacturer address: 4833 White Bear Parkway
St. Paul MN 55110, USA

The manufacturer hereby declares that the product:

Product name: Tracer AH541 modular configurable controller
Model numbers: BMTA000BAB00, BMTA000BAB01, BMTA000CAB00

Conforms to the following standards or other normative documents:

Electromagnetic emission: (by Council directive 89/336/EEC)	EN61000-6-4:2001	
	Radiated EN61000-3-2: Conducted EN61000-3-3: Amendment A14:2000	1995 Class B limit 1995 Class B limit
Electromagnetic immunity: (by Council directive 89/336/EEC)	EN61000-6-2:1999	±6.0 kV by contact
	IEC 1000-4-2:1995	±8.0 kV by air
	EN61000-4-2	
	IEC 1000-4-3:1995	10.0 V/m
	EN61000-4-3:1996	80 to 1000 MHz
	Amendment A1:1998	
	IEC 1000-4-4:1995	±2.0 kV ac power lines
	EN61000-4-4	±1.0 kV signal lines
	IEC 1000-4-5:1995	±2.0 kV
	EN61000-4-5	
IEC 1000-4-6:1996	10.0 V	
EN61000-4-6	0.15 to 80 MHz	
IEC 1000-4-8:1993		
EN61000-4-8		
IEC 1000-4-11:1994		
EN61000-4-11		

When and Where Issued

Electromagnetic Emission: 05/18/2001
Electromagnetic Immunity: 05/18/2001

Mark of Compliance:



John Olson
Design/Compliance Engineer

European contact

Societe Trane (Epinal, France)
1, rue des Ameriques, B.P. 6
F-88191 Golbey Cedex, France
Phone: (33) 329.31.73.00
Fax: (33) 329.81.24.98

This document validates CE conformity of the Tracer AH541 modular configurable controller.

Tracer, Trane, and the Trane logo are trademarks of Trane in the United States and other countries. All trademarks referenced in this document are the trademarks of their respective owners.



Literature Order Number	3270 3403 D
Date	June 2008
Supersedes	3270 3403 C

www.trane.com

For more information, contact your local Trane office or e-mail us at comfort@trane.com

Trane has a policy of continuous product and product data improvement and reserves the right to change design and specifications without notice.