

Installer's Guide

Crankcase Heater

(Bellyband Style) For Scroll Compressors (208-230V)

BAYCCHT301RES

60-watt heater for scroll compressors 6.5 - 7.5 in. diameter

BAYCCHT302RES

40-watt heater for scroll compressors 5.5 in. diameter

ALL phases of this installation must comply with NATIONAL, STATE AND LOCAL CODES

IMPORTANT — This Document is **customer property** and is to remain with this unit. Please return to service information pack upon completion of work.

⚠ WARNING: HAZARDOUS VOLTAGE - DISCONNECT POWER and DISCHARGE CAPACITORS BEFORE SERVICING

⚠ WARNING

This information is intended for use by individuals possessing adequate backgrounds of electrical and mechanical experience. Any attempt to repair a central air conditioning product may result in personal injury and/or property damage. The manufacture or seller cannot be responsible for the interpretation of this information, nor can it assume any liability in connection with its use.

⚠ WARNING

LIVE ELECTRICAL COMPONENTS!
During installation, testing, servicing, and troubleshooting of this product, it may be necessary to work with live electrical components. Failure to follow all electrical safety precautions when exposed to live electrical components could result in death or serious injury.

Kit Content:

Crankcase Heater (with wires) - Qty 1
Thermostat/Terminator - Qty 1
Wiring Diagram - Qty 1
Installer's Guide - Qty 1
Wire Nut - Qty 1

Inspection:

Check carefully for any shipping damage. This must be reported to and claims made against the transportation company immediately. Any missing parts should be reported to your supplier at once and replaced with authorized parts only.

Installation:

1. Place the thermostat selector switch in the OFF position.
2. Open all unit electrical switches.
3. Remove the unit's control box cover. Disconnect the fan motor leads. This will allow for complete removal of the top cover/fan assembly (step not required for side discharge models).
4. Place the Crankcase Heater Band around the bottom of the compressor. (See Figure 2)
5. Tighten the Crankcase Heater around the compressor and attach the green ground wire to the Compressor Terminal Housing. (See Figure 2 & 3)

6. Attach the Thermostat/Terminator on the compressor discharge line within 4" of the compressor.
7. Remove the louvered side panel to the right of the control box. To remove, push in the bottom/center section of the panel, while pulling upward, to slide the panel out of the unit (step not required for side discharge models).
8. Route the crankcase heater and thermostat/terminator leads along the existing compressor lead wires, **underneath the coil and up into the top of the control box (bold text not required for side discharge)**. Use wire ties to secure the crankcase heater wires to the compressor lead wires. Care must be taken to ensure the leads do not come in contact with the compressor discharge line, any moving parts, or any sharp edges.
9. In the control box, route the (Black crankcase heater lead with a 1/4" connector) to the compressor motor contactor (MS) and connect to L1. Route the (Purple) Thermostat/Terminator lead with a 1/4" connector down to the compressor motor contactor (MS) and connect to L2.
10. Connect the remaining (Black crankcase heater wire with the remaining (Purple) Thermostat/Terminator wire using the supplied wire nut.

NOTE: Connect both leads on the line side of the contactor. (See Figure 1)

11. Place the wiring diagram provided with the kit on the inside of the control box cover.
12. Reinstall the side panel and the unit top, and the control box cover (control box cover only for side discharge models).
13. Reapply power to the unit.
14. The crankcase heater should heat when the discharge line temperature is below 75°F and should stop heating when the discharge line is above 105°F.
15. Reset the thermostat selector switch from Step 1.

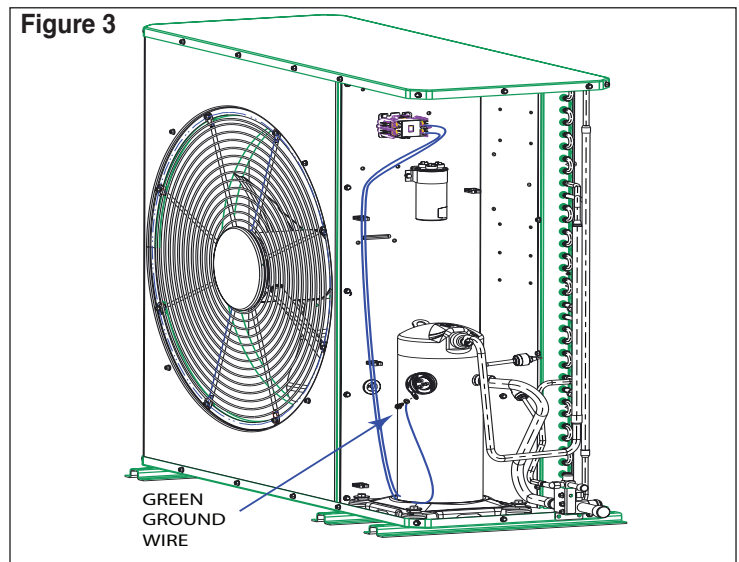
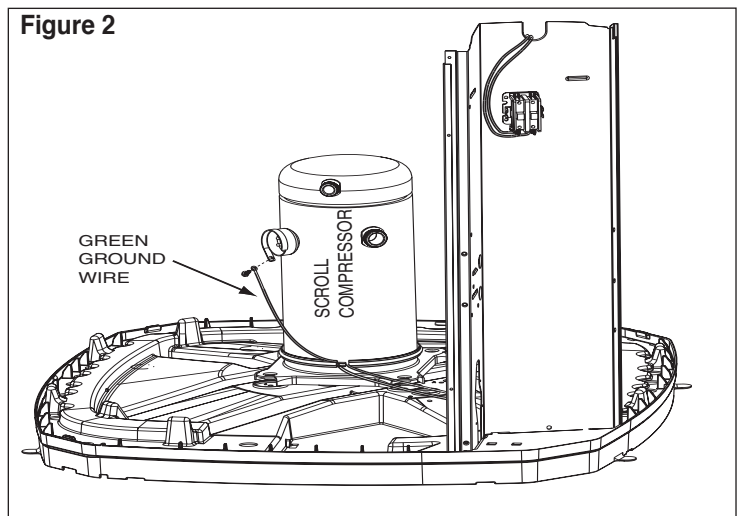
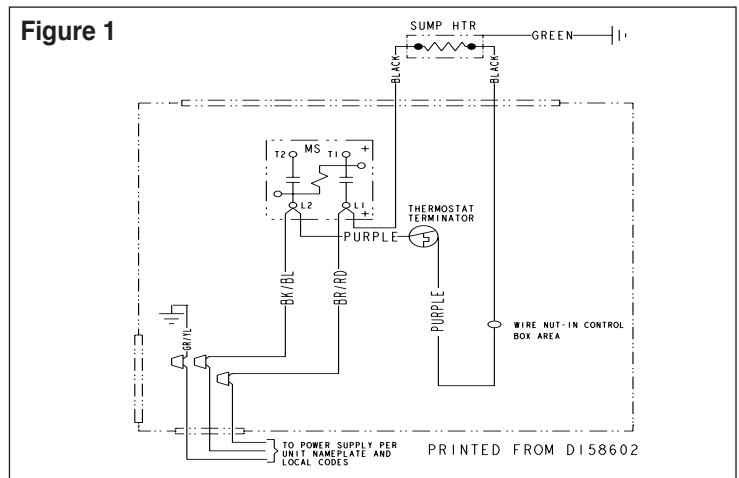

About Trane and American Standard Heating and Air Conditioning

Trane and American Standard create comfortable, energy efficient indoor environments for residential applications. For more information, please visit www.trane.com or www.americanstandardair.com

The manufacturer has a policy of continuous data improvement and it reserves the right to change design and specifications without notice. We are committed to using environmentally conscious print practices.

18-HE48D1-5A-EN 08 Jul 2020

Supersedes 18-HE48D1-5 (March 2017)

© 2020