

Installer's Guide

Low Ambient Control Kit

BAYLOAM103

⚠ WARNING: HAZARDOUS VOLTAGE - DISCONNECT POWER BEFORE SERVICING

ALL phases of this installation must comply with NATIONAL, STATE AND LOCAL CODES

IMPORTANT— This Document is **customer property** and is to remain with this unit. Please return to service information pack upon completion of work.

LOW AMBIENT KIT CONTENTS:

- 1 - Controller Module
- 1 - Liquid Line Temperature Sensor
- 1 - Outdoor Air Temperature Sensor
- 1 - B Y O Low Voltage Wiring Harness
- 1 - Sensor Clamp
- 1 - Thermal Grease
- 1 - Insulation Tape
- 1 - Information Label
- 3 - Screws, Wire Nuts, Wire Ties
- 1 - Installer's Guide.

INSPECTION:

Check carefully for any shipping damage. This must be reported to and claims made against the transportation company immediately. Any missing parts should be reported to your supplier at once and replaced with authorized parts only.

INSTALLATION:

NOTE:

As the head pressure control is applied to units operating in low ambient conditions, it is required that the units have compressor crankcase heaters and non-bleed txv's. Refer to the Low Ambient Application documentation.

ATTACH INFORMATION LABEL

Attach the Information Label to the control box cover. This label, identifies fan motor cycling during low ambient operation.

MOUNTING CONTROL MODULE

1. Be certain power to unit is **DISCONNECTED**.
2. Remove cover panel on control box compartment.
3. Install control module into the control box.
 - a. If installing into an air conditioner only unit (non heat pump), use the three (3) screws provided and attach to the control box as illustrated in Figure 1.
 - b. If installing into a heat pump unit, remove the three (3) screws holding the defrost board, place low ambient kit assembly behind the defrost board and reattach the defrost board and low ambient control with the three (3) screws provided in the original defrost board mounting location. See Figure 1.

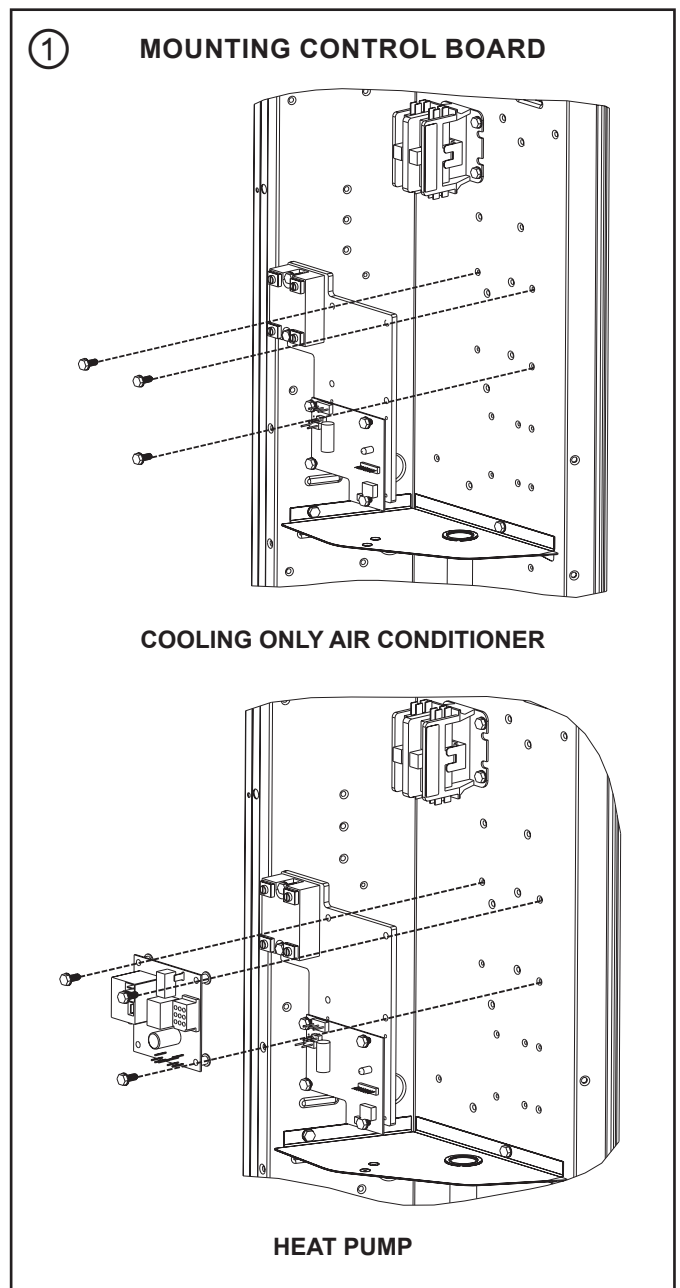

Installer's Guide

MOUNTING LIQUID LINE TEMPERATURE SENSOR

4. Remove the service access panel to the left side of the control box of the air conditioner or heat pump.
5. Attach the liquid line sensor to the liquid line:
 - a. If installing on a cooling only air conditioner unit, attach the liquid line sensor to the liquid line near the drier assembly. Apply thermal grease (supplied) to the liquid line, where the sensor will be mounted. Using the clamp provided, attach the sensor as shown; Figure 2A. When completed, wrap the complete assembly with the insulation tape.
 - b. If installing on a heat pump unit, attach the liquid line sensor to the liquid line running vertically, directly behind the control box. Apply thermal grease (supplied) to the liquid line, where the sensor will be mounted. Using the clamp provided, attach the sensor assembly as shown; Figure

- 2B. When completed, wrap the complete assembly with the insulation tape provided.
6. Route the sensor leads through the low voltage access hole and attach to the two (2) pin connector provided on the control board. See Figure 3.

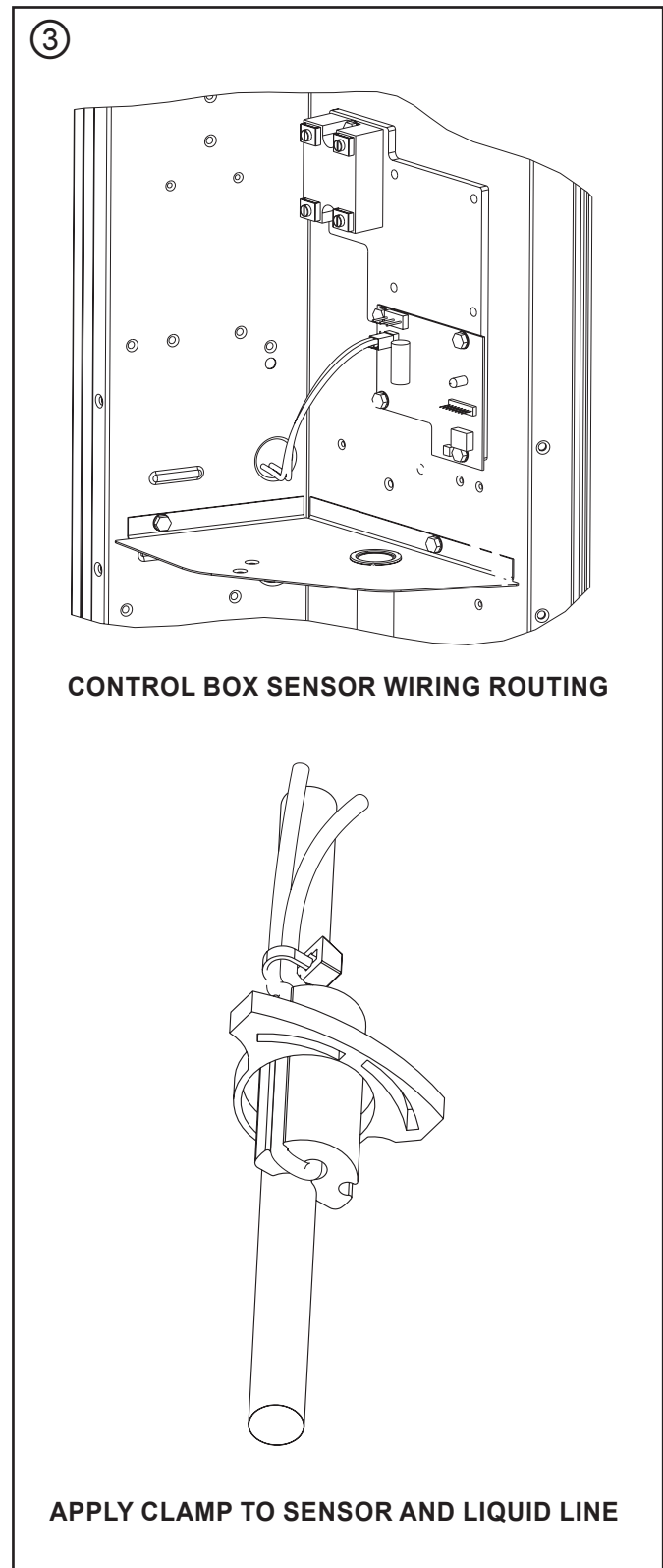
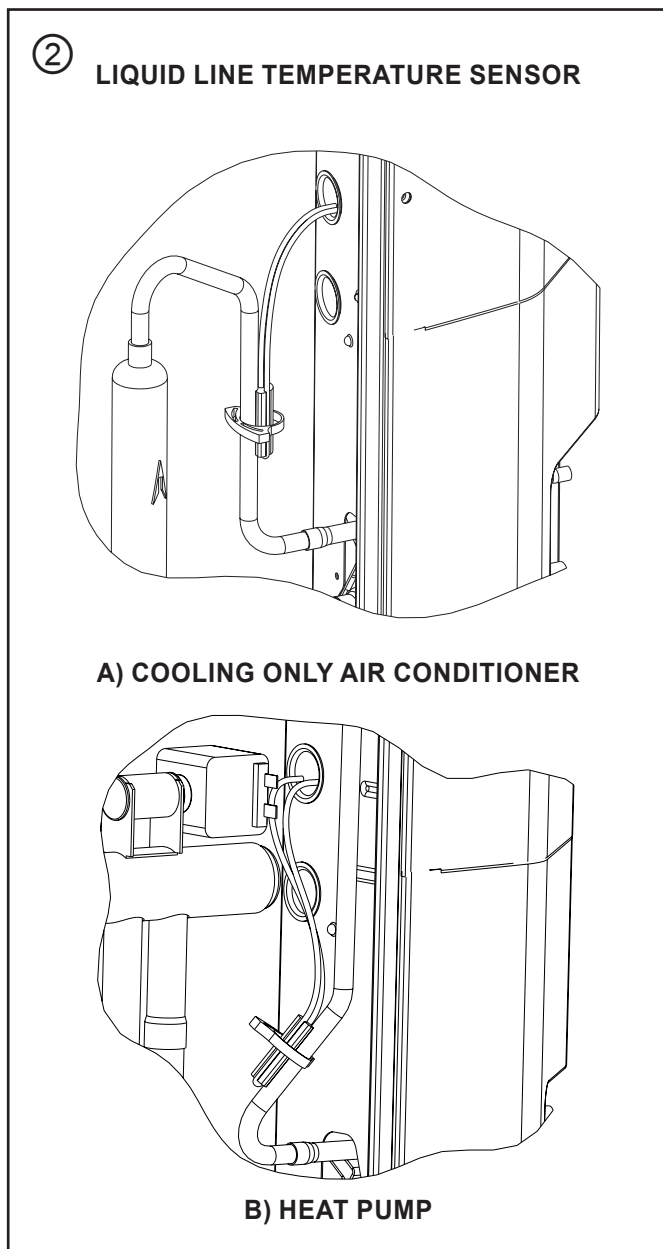

MOUNTING OUTDOOR TEMPERATURE SENSOR

7. Using pliers, bend the corner of the control box base downward, to create an opening for the sensor leads. See Figure 4.
8. Route the sensor, from the control board, down through the opening created in the control box base. With wire tie provided, secure the sensor to the low voltage wiring or conduit below the control box base. Place the wire tie on the sensor wires (not on the sensor) and dress so that the temperature sensing area is not in direct contact with any surrounding surfaces and is not in direct sunlight.

WIRING CONTROL MODULE

9A) Cooling Only Air Conditioner Models: See Figure 5
 5 Disconnect the black fan motor lead from the contactor (This wire is attached to contactor terminal "T2", with a quick connect terminal). Reconnect this fan motor lead to the black wire from the solid state relay on the control module. This wire has a sleeved, 1/4" male tab for attaching to the fan motor wire terminal.

Connect the other black wire from the solid state relay to the contactor terminal "T2" (from where the fan motor lead was disconnected).

Low voltage wires:

Connect the 3-pin wire assembly to J5 on the control board (3-pin male connector).

NOTE:

To ease the insertion of the connector housing onto the J5 header, place the connector on the tips of the three header pins. Angle the connec-

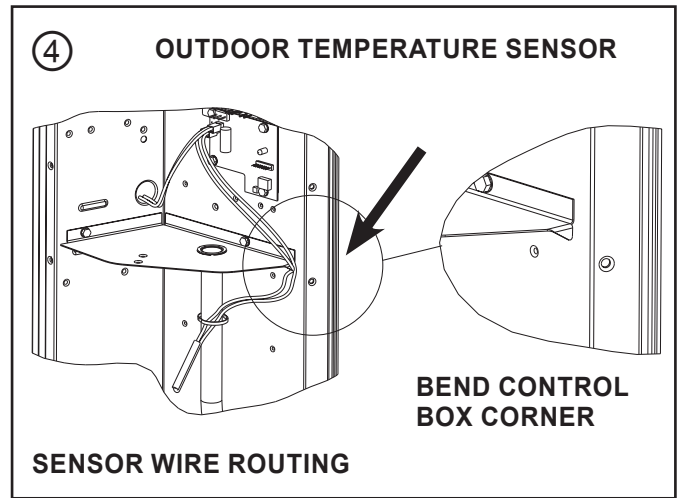

tor upward toward the header latch while pushing connector over the header pins.

Connect the yellow lead wire to a 1/4" male tab on the right hand side of the main contactor (low voltage contactor coil terminal).

Connect the blue lead wire to the wire nut junction of the blue wire.

Connect the orange wire to the wire nut junction of the yellow wire.

(New wire nuts are provided)

⑤

AIR CONDITIONING / COOLING ONLY

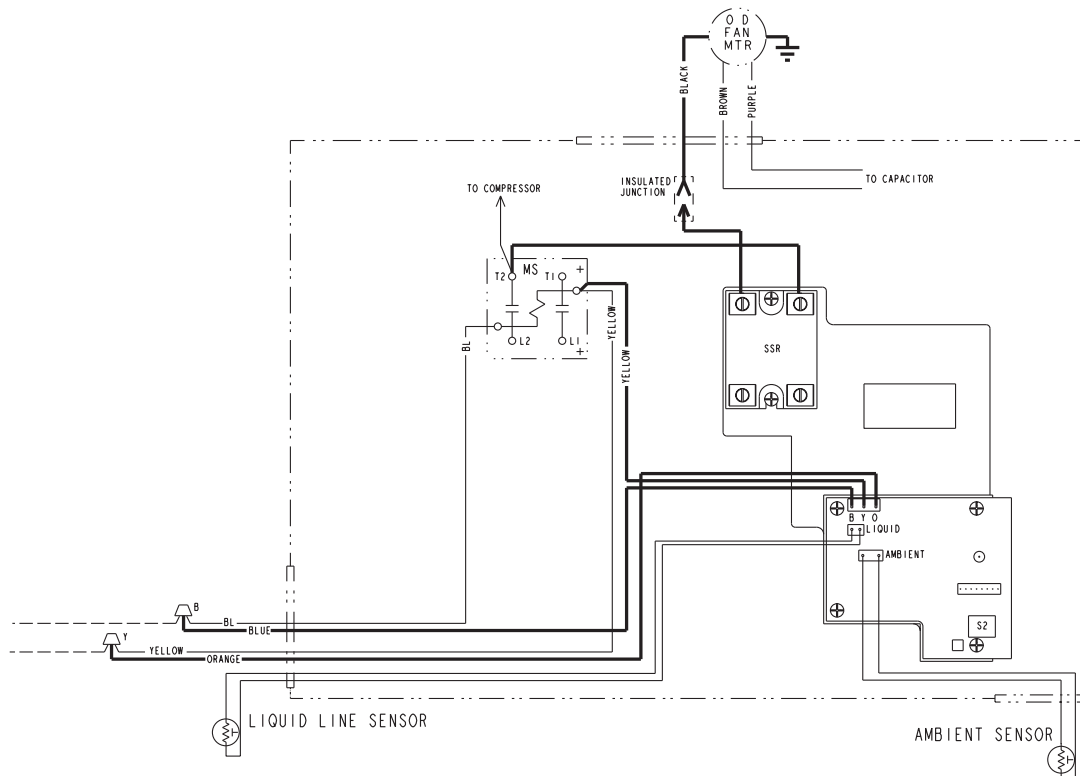

PRINTED FROM D153272P02

Installer's Guide

9B) 200/230 Volt Heat Pump: See Figure 6

Disconnect the black fan motor lead from the defrost board relay (The black wire is attached to the "N.C." terminal of the relay).

CAUTION

FIRMLY HOLD RELAY WHEN REMOVING WIRE.

Reconnect this fan motor lead to the black wire from the solid state relay on the control module (This wire has a sleeved, 1/4" male tab for attaching to the fan motor lead wire terminal).

Connect the other black wire from the solid state relay to the "N.C." terminal on the defrost board relay (from where the fan motor was disconnected).

Low voltage wires:

Connect the 3-pin wire assembly to J5 on the control board (3-pin male connector).

NOTE:

To ease the insertion of the connector housing on to the J5 header, place the connector on the tips of the three header pins. Angle the connector upward toward the header latch while pushing connector over the header pins.

Connect the yellow lead wire to a 1/4" male tab on the right hand side of the main contactor (low voltage contactor coil terminal).

Connect the blue lead wire to the wire nut junction of the blue wire.

Connect the orange lead wire to the wire nut junction of the orange wire.

(New wire nuts are provided.)

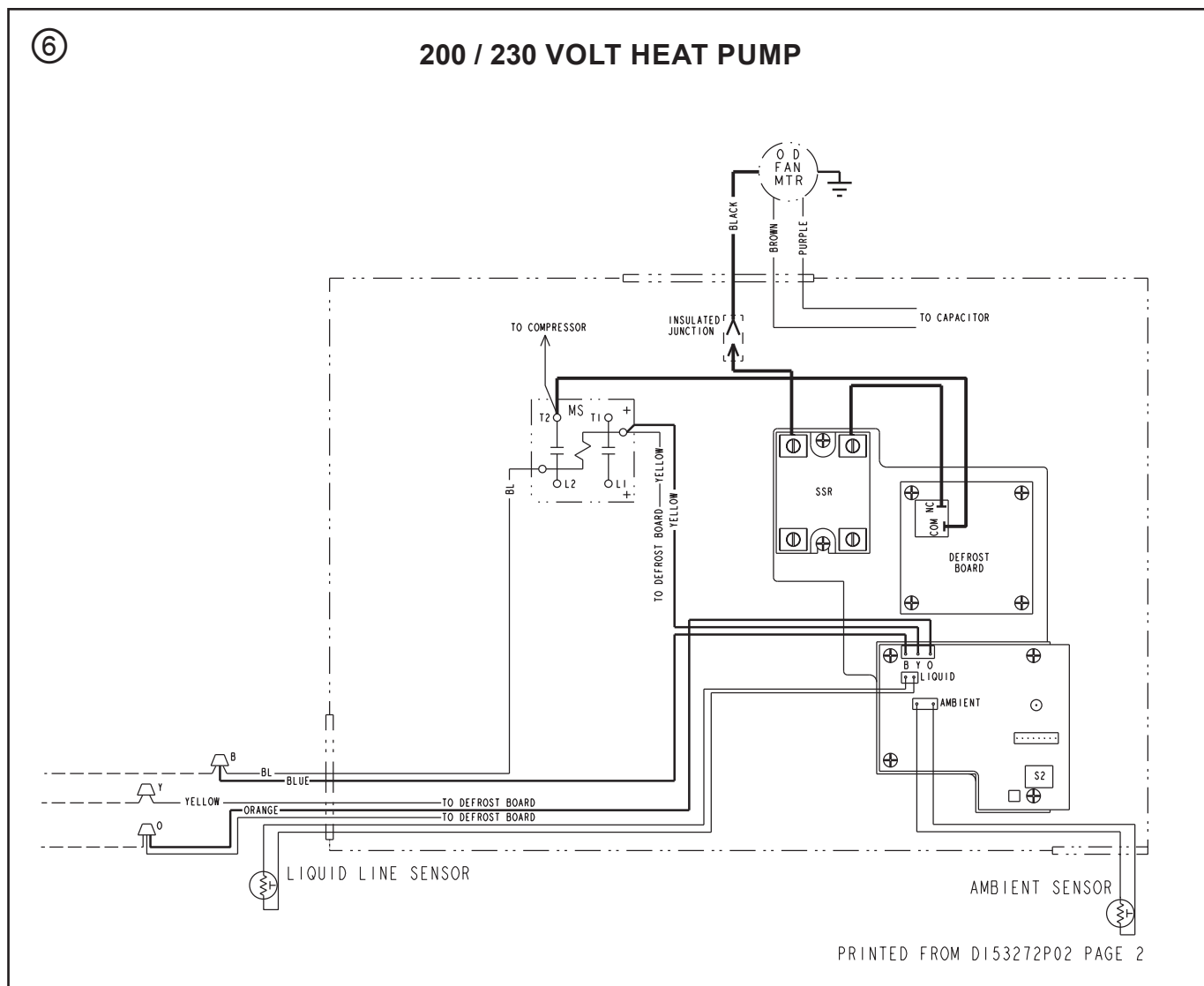

9C) 460 Volt Heat Pump Models: See Figure 7

Disconnect the black fan motor lead from the fan relay (terminal #6). Reconnect this black motor lead to the black wire from the solid state relay on the control module (This wire has a sleeved, 1/4" male tab for attaching to the fan motor lead wire terminal).

Connect the other black wire from the solid state relay to terminal #6 of the fan relay (from where the fan motor wire was disconnected).

Low voltage wires:

Connect the 3-pin wire assembly to J5 on the control board (3-pin male connector).

NOTE:

To ease the insertion of the connector housing onto the J5 header, place the connector on the tips of the three header pins. Angle the connector upward toward the header latch while pushing connector over the header pins.

Connect the yellow lead wire to a 1/4" male tab on the right hand side of the main contactor (low voltage contactor coil terminal).

Connect the blue lead wire to the wire nut junction of the blue wire.

Connect the orange lead wire to the wire nut junction of the orange wire.

(New wire nuts are provided.)

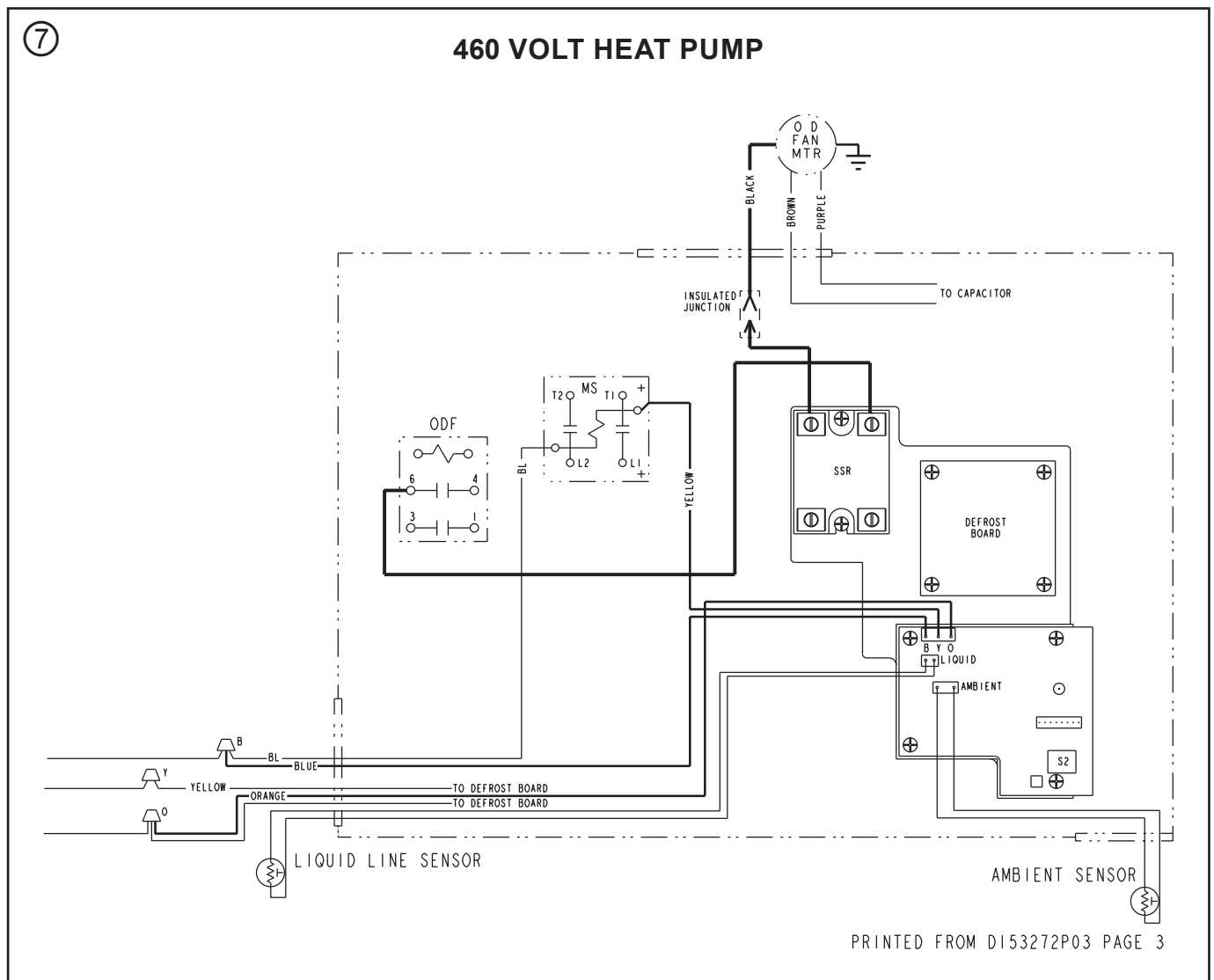

Installer's Guide

SYSTEM SETUP

10. The control board contains a momentary test switch (S1) and a 4-position installer selectable dip switch (S2). Both components are located in the lower right hand corner of the control board. See Figure 8.

TEST SWITCH

The test switch provides a means of verifying that the fan motor is under the control of the Low Ambient Controller. A "Y" signal must be present in order to test the control. Depressing the test switch causes the fan to alternately cycle on (for 3 seconds) and off (for 3 seconds) for a total time of 12 seconds. The on/off fan operation may be observed by watching the fan once the test function has been invoked or by monitoring the head pressure using a gauge set. The LED on the solid state relay should light when voltage is being applied to the fan motor. Once the 12-second test period is complete the control resumes normal control operation.

DIP SWITCHES

The controller will control to a liquid temperature set point as determined by the dip switch settings. The dip switch is used:

1. To select either Automatic Mode or Manual Mode operation (S2 dip switch 4 setting).
2. To select the liquid temperature set point (S2 dip switch 1, 2 and 3 settings).

Automatic Mode (S2 dip switch 4 in "Off" position) – The controller determines the *approach temperature* based upon the liquid and ambient temperature readings. The *approach temperature* = liquid temperature – ambient temperature. The approach temperature is calculated only when the ambient temperature is in the range of 65 to 75 deg. F. and the outdoor fan is on continuously. If the controller has not yet acquired an approach temperature, S2 dip switch 1, 2 & 3 settings are used for determining the liquid temperature set point the same as in Manual Mode. If the controller has acquired an *approach temperature*, then the liquid temperature set point is determined as follows:

$$\text{Liquid Temperature Set Point} = \text{Approach Temperature} + 70 \text{ deg. F.}$$

Manual Mode (S2 dip switch 4 in "On" position) – The S2 dip switch 1, 2, 3 settings are read by the controller and used to determine the liquid temperature set point when

1. Y is first applied
2. and after initial start-up mode completion, i.e., during the system control mode (no sooner than six minutes after Y is applied). The liquid temperature set point will not change during system start-up.

The dip switches should be set prior to initial application of the Y signal to the controller.

The dip switches should be set for each specific HVAC system based upon the following instructions:

Determine Liquid Temperature Set Point

Reference appropriate high side charging chart for the unit; liquid pressure for cooling units and head pressure for heat pump units.

Locate the high side pressure for 70 deg. F. outdoor temperature at the expected indoor wet bulb temperature. Correct the high side pressure according to the specific indoor unit being used. For Heat pumps subtract 7 psi, for cooling only units subtract zero psi. Using the refrigerant properties chart, find the saturation temperature for the calculated liquid pressure. Subtract the anticipated sub-cooling temperature (typically 12 degrees) from the saturation temperature to obtain an estimate of the liquid temperature. Set S2 dip switch 1, 2 and 3 settings to the nearest liquid temperature set point in the table below.

S2 Dip Switch 4; Off – Automatic Mode (recommended setting)
On – Manual Mode

LIQUID TEMP SET POINT°F	DIP SWITCH 1	DIP SWITCH 2	DIP SWITCH 3
70 °F	OFF	OFF	OFF
76 °F	OFF	OFF	ON
82 °F	OFF	ON	OFF
88 °F	OFF	ON	ON
94 °F	ON	OFF	OFF
100 °F	ON	OFF	ON
106 °F	ON	ON	OFF
112 °F	ON	ON	ON

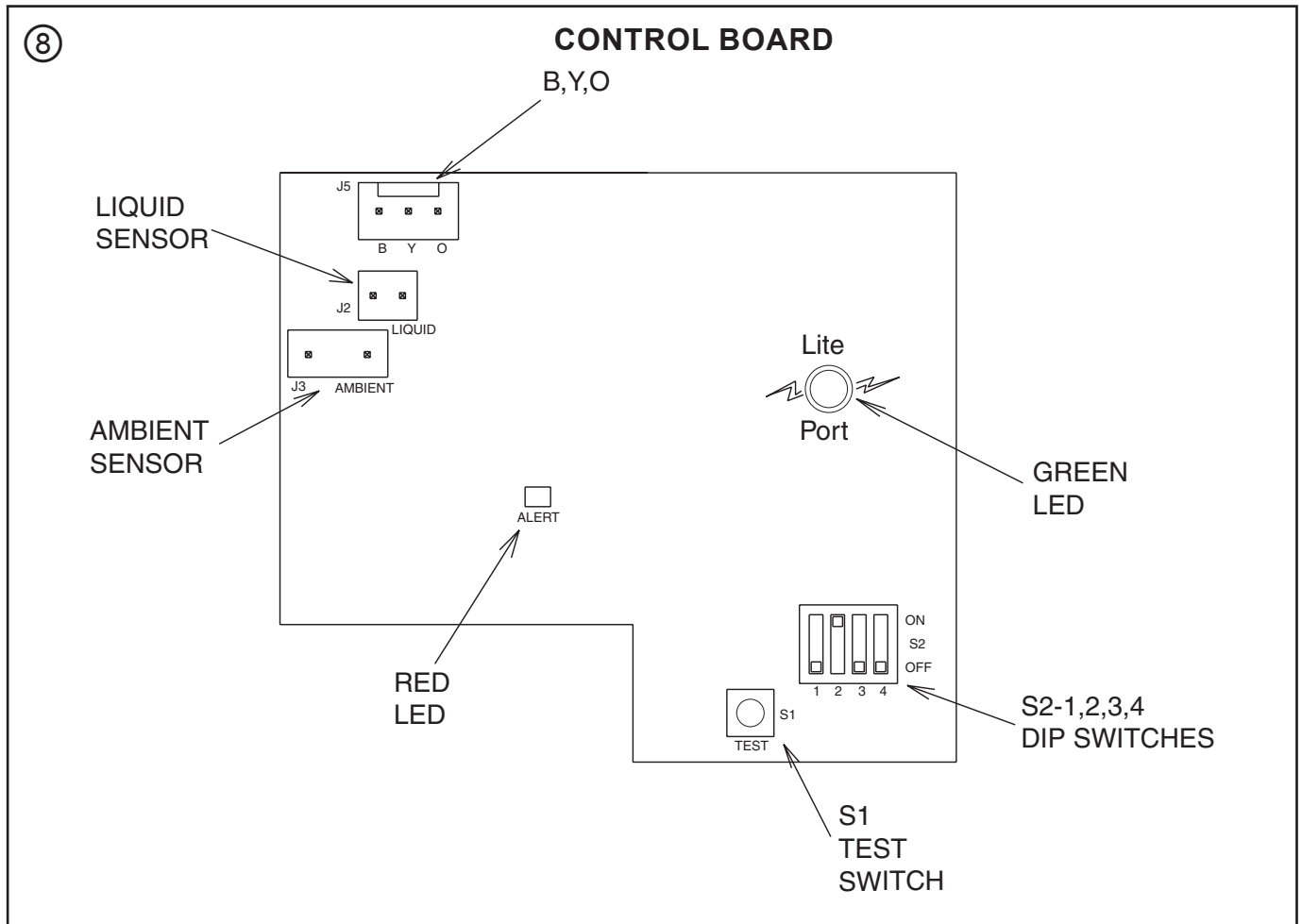

LEDS

The control board contains two LEDs; one green and one red surface mount. The green LED is a status indicator labeled LitePort on the control board and flashes at a 1/2 second on (plus fast blink at the end for LitePort data) and 1/2 second off rate in the cooling mode. In the heating mode the green LED is full on with a blink/flicker OFF (LitePort data transmission) every second.

The red LED is a small surface mount component located near the end of the large capacitor. The red LED is labeled ALERT on the control board. The red LED indicator is normally off. If the red LED is on or flashing then a fault is indicated according to the following:

Red LED Flashing 1/10 Second ON – 1/10 Second Off – Liquid Sensor Fault

Red LED Flashing 1/2 Second ON – 1/2 Second Off – Ambient Sensor Fault

Red LED continuously ON – I²C EEPROM Fault board failure which cannot be field repaired

If the cause of a fault is cleared or repaired then the red LED fault indication will clear with the removal and reapplication of 24 VAC power (Y) to the control.

The solid state relay on the control module also contains a green LED indicator. This LED indicates when the solid state relay is energized by the control. If the control is cycling the fan then this LED will be on/off accordingly.

SYSTEM CHECK-OUT – COOLING UNITS ONLY

Verify that the control module is installed and wired per the instructions contained within this installer's guide. (J5-Blue connected to "B", J5-Yellow connected to "Y", J5-Orange connected to "Y", Liquid sensor installed and connected, ambient sensor installed and connected).

If uncertain about S2 dip switch 1, 2, 3, 4 settings, leave in the factory preset position.

Apply power to the unit. Apply "Y" control signal.

Verify the green LED is flashing at 1/2 second ON 1/2 second OFF rate.

Verify no red LED faults are present.

The fan should run continuously for a minimum of 10 seconds after "Y" is applied. After 10 seconds the control may begin to cycle the fan if the ambient outdoor temperature is 70 deg. or below. If the fan is cycling and the outdoor temperature is below 70 deg., the control is working. If after 10 seconds of "Y" application the fan is on continuously, the TEST Switch (S1) may be used to verify the Control Module has control over the fan. Momentarily depress the TEST Switch (S1) on the control board. The fan should then cycle 3 seconds on then 3 seconds off for 12 seconds.

NOTE:

If the green LED on the control board is full on with a blink/flicker OFF every second make certain the orange wire from the control board is connected to "Y" per these instructions.

Installer's Guide

SYSTEM CHECK-OUT – HEAT PUMP

Verify that the kit is installed and wired per the instructions contained within this installer's guide. (J5-Blue connected to "B", J5-Yellow connected to "Y", J5-Orange connected to "O", Liquid sensor installed and connected, Ambient sensor installed and connected).

If uncertain about dip switch settings (S2-1, 2, 3, 4), leave in the factory preset position.

Apply power to the unit. Apply "Y" and "O" control signal.

Verify the green LED is flashing at 1/2 second ON 1/2 second OFF rate.

Verify no red LED faults are present.

The fan should run continuously for a minimum of 10 seconds after "Y" and "O" have been applied. After 10 seconds the control may begin to cycle the fan if the ambient outdoor temperature is 70 deg. or below. If the fan is cycling and the outdoor temperature is below 70 deg., the control is working. If after 10 seconds of "Y" application the fan is on continuously, the TEST Switch (S1) may be used to verify the Control Module has control over the fan. Momentarily depress the TEST Switch (S1) on the Control board. The fan should then cycle 3 seconds on then 3 seconds off for 12 seconds.

NOTE:

If the green LED is full on with a blink/flicker OFF every second make certain the orange wire from the control board is connected to "O" per these instructions and the "O" signal is present.

The control board will leave the fan ON continuously during heating mode, i.e., No "O" signal present. The green LED is full on with a blink/flicker off every second in the heating mode.

About Trane and American Standard Heating and Air Conditioning

Trane and American Standard create comfortable, energy efficient indoor environments for residential applications. For more information, please visit www.trane.com or www.americanstandardair.com

The manufacturer has a policy of continuous data improvement and it reserves the right to change design and specifications without notice. We are committed to using environmentally conscious print practices.