

TZONE940AC52Z Communicating Sensor with Display

Table of Contents

Overview.....	2
Operation.....	3
Installation	11



Scan to see
installation and
help videos for
the 940 Sensor.

**User &
Installation
Guide**

Section 1. General Information

1.1 Overview

This sensor is a wall mounted low voltage control that allows a user to control the temperature in the respective zone.

The sensor can be used in two different ways:

- Stand-alone remote indoor temperature and relative humidity sensor.
- Temperature and relative humidity* sensor used to control individual zones in zoning applications.

* For zoning applications, relative humidity control is a system-level function. The 950 Control allows the user to select the humidity-controlling zone.

*NOTE: For proper operation, some features of the 940 Sensor require software version 2.2 or later on the 950 Control. Before proceeding, please be sure the 950 Control is running software version 2.2 or later.

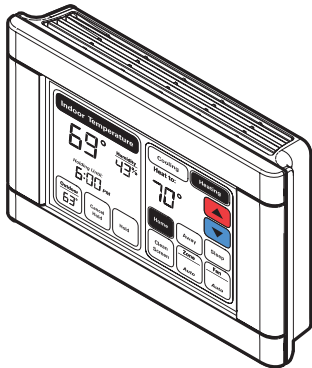

Section 2. Operation

2.1 Buttons and Indicators

The diagram shows a thermostat control panel divided into two main sections: **System Status** and **Setpoints/Adjustments**.

System Status: Displays Indoor Temperature (70°), Humidity (38%), Current Time (12:39 PM), and Outdoor Sensor (40°). It also includes a Hold button.

Setpoints/Adjustments: Features Cooling and Heating modes, a Heat to: setpoint (70°), and buttons for Home, Away, Sleep, Clean Screen, Zone, Fan, and Auto.

Callouts:

- ① Notification Icons: Located at the top left of the display.
- Room Temperature: Points to the indoor temperature display.
- Indoor Relative Humidity: Points to the humidity percentage display.
- Current Time (from 950 Control): Points to the time display.
- Outdoor Sensor: Points to the outdoor temperature display.
- ② Setpoints: Points to the Heat to: display.
- ③ Presets: Points to the Home, Away, and Sleep buttons.
- ④ Fan Mode: Points to the Fan and Auto buttons.
- ⑤ Hold: Points to the Hold button.



Display Selection: Selecting Cooling or Heating shows the setpoint and allows manual temperature adjustment.

Clean Screen: When touched, the unit ignores input for 30 seconds so the screen can be wiped with a damp cloth.

Zone Mode: The mode can be set to Auto, Cool, Heat or Off.

IMPORTANT: Do not use household cleaners or spray cleaners, including water spray to clean the 940 zone sensor screen or enclosure. Household cleaners and sprays may cause permanent damage to the zone sensor.

① Icons

-  **Alert Triangle** – A critical alert has been detected. Contact servicing dealer.
-  **Signal Icon** – The communicating sensor has lost communication. Contact servicing dealer.
-  **Lock Icon** – Indicates the screen has been locked by the 950 Control. When this lock is present, the sensor will not respond to any keypad presses.

② **Setpoints** - The setpoint is the desired temperature for each mode (*Heating or Cooling*).

Select the heating or cooling button to adjust the temperature for that mode. Using the red or blue arrow, adjust the temperature up or down.

If scheduling is enabled on the 950 Control, changing the setpoint on the 940 Sensor overrides the scheduled setpoint until the next scheduled period. See the Hold section for additional information.

③ **Presets** - Three presets allow one-touch control of conditions.

Note: *buttons will not be present if disabled from the 950 Control. (See Section 2.2)*

These preset buttons on the 940 Sensor are configured from the 950 Control and allow one-touch convenience for the common situations of *Home, Away or Sleep*.

These preset values are temporary and will revert to the 950 Control's scheduled settings at its next scheduled period.

④ **Fan Mode** - Fan Mode is a system-level function. Changing the fan mode at any sensor will change the system fan mode to reflect the last fan setting.

⑤ **Hold** - This sensor offers three variations of Hold functionality that override the scheduled setpoints.

Temporary Hold

Permanent Hold

Hold Until

NOTE: The Hold button is only visible when a schedule is enabled on the 950 Control.

Press *Cancel Hold* to resume schedule.

Temporary Hold - This feature temporarily overrides the scheduled setpoints until the next scheduled period.

1) Adjust Setpoint - Adjust the setpoint to the desired setting by pressing the up and down arrows. After approximately 5 seconds, the screen will display Holding Until with the time of the next scheduled period. To cancel, press Cancel Hold.

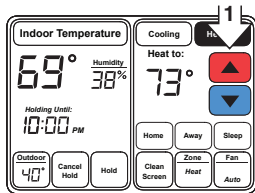

Permanent Hold - This feature is used to permanently override the scheduled setpoints. Settings will persist until hold is canceled at either the 940 Sensor or the 950 Control.

1) Press Hold - Press Hold one time to enter Permanent Hold mode. This zone's schedule will be overridden and PERMANENT HOLD appears on the display.

2) Adjust Setpoint - Adjust the setpoint to the desired setting. To cancel, press Cancel Hold.

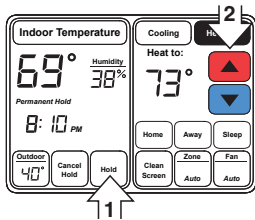

Hold Until - This feature overrides the scheduled setpoint until a user selected time is reached.

1) Press Hold Two Times - Press Hold two times to enter Hold Until mode.

2) Adjust Setpoint - Adjust the setpoint to the desired setting.

3) Set End Time - Set the time to return to the scheduled setpoints. The screen will show Holding Until with the selected time. To cancel, press Cancel Hold.

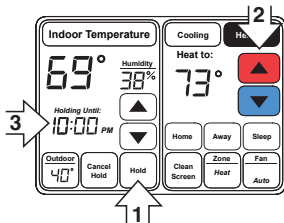

Normal Operation

When a 940 Sensor is following a schedule, the screen will appear in this manner.

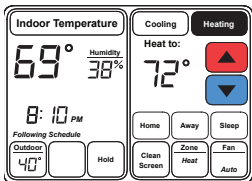

2.2 940 Sensor's Screen Layout

The screen layout of the 940 Sensor can be customized through the 950 Control.

MENU > SETTINGS >
SCREEN SETTINGS > ZONE SENSOR



Select the desired display settings. These settings will update on the 940 Communicating Sensor after selecting APPLY.

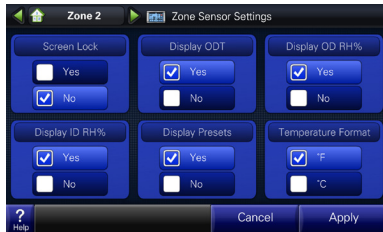

NOTE: If a zone without a 940 Communicating Sensor is currently displayed, the following screen will appear. Please note the zone in the top left.

Press either of the green arrows to switch to the appropriate zone.



Section 3. Installation

3.1 Contents and Specifications

The following parts are included in product model TZONE940AC52Z:

- 1 - Communicating Sensor
- 1 - Base
- 2 - Mounting screws/anchors
- 1 - Installation/User's Guide

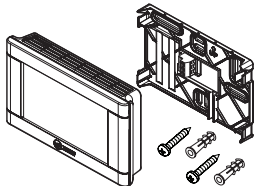

Specification	Description
Product Model:	ZONE940AC52Z
Product:	ComfortLink II™ Communicating Sensor
Size:	5.5" width x 3.4" height x 1.1" depth
Storage Temperature:	-40°F to 170°F, 0% - 95% RH
Operating Temperature:	32°F - 120°F, 5% - 90% RH non-condensing
Power:	24 VAC from HVAC System (Range: 18-32 VAC)
Power Consumption:	2 VA
Wire usage:	Minimum 18 gauge NEC approved control wiring



Scan to see a video on installing and setting up the 940 Zone Sensor.

3.2 Zone Sensor Location Considerations

The 940 Communicating Sensor is designed for installation in climate controlled living spaces.

It is recommended to place the sensor in central locations with good circulation. Avoid exterior walls and areas too near windows, doors, vents or concealed pipes or chimneys.

Important: If an air source is directed at or above the sensor, heat from the screen can be trapped within the sensor body and can cause the indoor temperature to be biased.

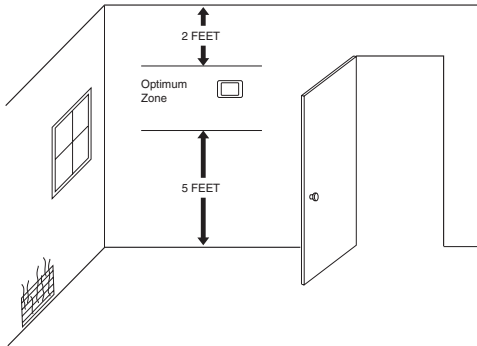

3.3 Physical Mounting

Remove cover by grasping at edges and gently pulling the cover straight towards you. It should release without much effort.

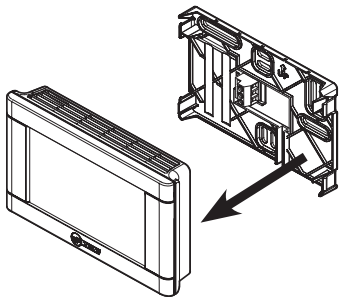

Be sure wires are routed through the center of the base plate and are long enough to connect to terminals.

For convenience multiple hole patterns are provided. Select and mark two opposing holes. A level may be used to ensure accuracy.

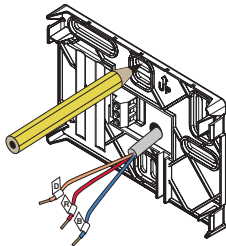

Mounting to studs:

Drill 1/8" pilot holes in the 2 locations marked above.

OR

Mounting to drywall:

Drill 3/16" pilot holes for anchors (included with the control) in the 2 locations marked above.

Gently tap anchors into the holes.

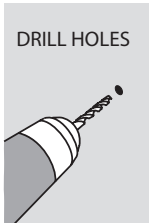

1/8" for screws
into studs



3/16" for drywall
anchors

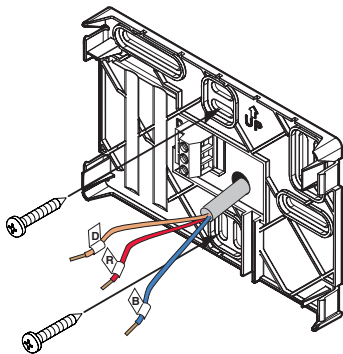

Attach base to wall using 2 screws
provided. Do not overtighten.

3.4 Wiring

Connect power leads to the D, R and B terminals.

- Wire data to D.
- Wire 24 VAC hot to R.
- Wire common to B.

NOTE: All wall penetrations **MUST** be sealed to prevent temperature biasing.

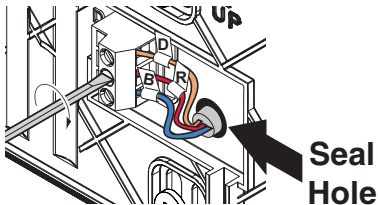

⚠ WARNING

This information is intended for use by individuals possessing adequate backgrounds of electrical and mechanical experience. Any attempt to repair a central air conditioning product may result in personal injury and/or property damage. The manufacture or seller cannot be responsible for the interpretation of this information, nor can it assume any liability in connection with its use.

⚠ CAUTION

CAUTION: EQUIPMENT DAMAGE HAZARD - Improper wiring can lead to equipment damage. Follow the terminal connection information carefully to ensure the control is wired properly. After wires are secure, bare wires **MUST NOT** touch each other. See the Field Wiring Diagrams for specific system applications.

⚠ WARNING

LIVE ELECTRICAL COMPONENTS! - During installation, testing, servicing, and troubleshooting of this product, it may be necessary to work with live electrical components. Failure to follow all electrical safety precautions when exposed to live electrical components could result in death or serious injury.

3.5 Setting Zone Address

Setting up the 940 Sensor is a two-step process.

BOTH steps MUST be performed.

STEP 1 – Setting the 940 Sensor's address:

1. Verify that the Setup Number is "1" and if not adjust it using red/blue arrows.
2. Select SYSTEM ZONE address by adjusting with black arrows. SETTING display will not adjust until setting is accepted below.
3. Pressing DONE saves changes and exits the setup screen.

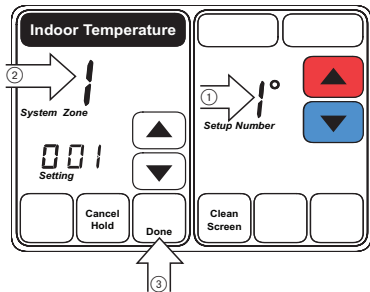

At initial power-up, the 940 Sensor Setup Screen (shown above) will automatically appear.

To re-enter the setup screen, press and hold INDOOR TEMPERATURE for approximately five seconds.

STEP 2 – Assigning the 940 Sensor to the corresponding damper in the 950 Control.

1. From the 950 Control verify that is running software version 2.2 or later. If not, a software upgrade is required before the 950 will recognize 940 Sensors.
2. Navigate to:
MENU > SERVICE > TECHNICIAN ACCESS >
PROCEED > ZONE SENSORS.
3. Select the corresponding damper on the left side of the screen.
4. Select the appropriate sensor on the right side of the screen
5. Press ASSIGN.

Repeat these steps for all communicating sensors. See the Zone Panel literature for more information.

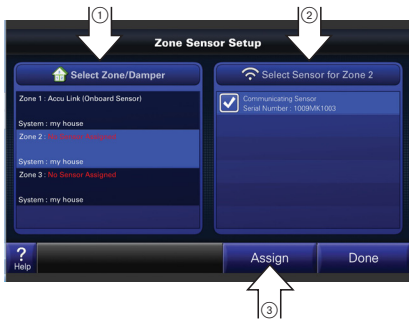

Scan to see a video on how to set up zoning with the 940 Sensor.

NOTE: If you need to re-enter this setup screen, press and hold INDOOR TEMPERATURE for approximately 5 seconds.

Important: Once the 940 Sensor's address has been selected and the sensor has been associated to a zone in the 950 Control, changing the address at the 940 Sensor will have no effect on the zone assignment. To change zone assignment, see below.

3.6 Changing the Zone Assignment

If the 940 Sensor's address has been set and assigned to a zone in the 950 Control, use the following steps to change the 940 Sensor's assignment.

1. Change the 940 Sensor's address.
2. On the 950 Control, navigate to:
MENU > SERVICE > TECHNICIAN ACCESS >
PROCEED > ZONE SENSORS
3. Select the appropriate zone.
4. Select the UNASSIGN button.
5. Select the new zone.
6. Select the sensor.
7. Press the ASSIGN button.





3.7 Optional User Display Settings

The setup screen allows changing of display settings. These features can be adjusted by changing the SETUP NUMBER and changing the SETTING range in the same manner as the Zone Address was set in the previous section. Please see the matrix below.

NOTE: To enter this setup screen, press and hold INDOOR TEMPERATURE for approximately 5 seconds.

940 Sensor Setup Table				
	Data	Setup Number	Setting Range	Default Setting
ONLY for Installers	Zone Address	1	1-8	1
User Settings	Active Brightness	2	0-10	10
	Standby Brightness	3	0-10	0
	Backlight Timeout	4	5-60 (sec)	10
	Clean Screen Timeout	5	5-60 (sec)	30

3.8 Troubleshooting

Troubleshooting Issues			
Icon	Condition	950 Control Displays	Solution
Alert Icon 	Indoor temperature sensor has failed/stopped reporting	An associated SOP.004.00 will be displayed on the 950 control	Use the 950 Diagnostic screen to troubleshoot alert
	Indoor humidity sensor has failed/stopped reporting	An associated SOP.004.03 will be displayed on the 950 control	Use the 950 Diagnostic screen to troubleshoot alert
	One of the keypad segments is stuck	NA	Replace the sensor
Signal Icon 	Hidden	NA	Normal Operation
	Solid	NA	Sensor has not been discovered by 950 control
	Flashing	After 2 minutes, SOP.004.00 will be displayed on the 950 control	Indicates a loss of communications
Lock Icon 	Indicates the screen has been locked by the 950 control. When this lock is present, the sensor will not respond to any keypad presses.		
NA	No display	After 2 minutes, SOP.004.00 will be displayed on the 950 control	24VAC Power is lost on the 940 Sensor

BASE LIMITED WARRANTY

Subject to the terms and conditions of this limited warranty, Trane U.S., Inc. ("Company") extends a limited warranty against manufacturing defects for the product(s) identified in Tables 1, 1A, 1B attached hereto ("Products") that are installed in a residential/multi-family application (personal, family or household purposes) under normal use and maintenance in the United States and Canada.

This limited warranty applies to Products manufactured on or after August 1, 2011.

In order to maximize the available benefits under this limited warranty, the Purchaser (as defined below) should read it in its entirety. All repairs of Product parts covered under this limited warranty must be made with authorized service parts and by a licensed HVAC service provider. Additionally, commercial applications are treated differently under this limited warranty as stated in Tables 1, 1A, 1B attached hereto. For purposes of this limited warranty, "commercial applications" shall mean any application other than for personal, family, or household use.

TERM: The limited warranty period for Products is as stated in Tables 1, 1A, 1B attached hereto. If the Purchaser properly registers the Products, the limited warranty period shall be extended as stated in Tables 1, 1A, 1B attached hereto. Regardless of registration, the Commencement Date for a limited warranty period shall be the date that the original installation is complete and all Product start-up procedures have been properly completed and verified by an installer's invoice. If the installation and start-up date cannot be verified by the installer's invoice, the Commencement Date shall be sixty (60) days after the factory manufacture date which is verified by the Product serial number. Where a Product is installed in a newly constructed home, the Commencement Date is the date the Purchaser purchased the residence from the builder. Proof of Product purchase, installation, and/or closing date of the residence may be required to confirm the Commencement Date.

The installation of Product replacement parts under this limited warranty shall not extend the original warranty period. The warranty period for any Product part replaced under this limited warranty is the applicable warranty period remaining under the original Product warranty.

WHO IS COVERED: This limited warranty is provided only to the original owner and his or her spouse ("Purchaser") of the residence where the Products are originally installed. This warranty is not transferable except according to terms stated on the applicable website identified below under Registration Requirements. Company has the right to request any and all proof of Product purchase or installation and/or closing date of the residence.

WHAT COMPANY WILL DO: Company may request proof of Product purchase and/or installation in order to provide Product parts under this limited warranty. As Company's only responsibility and Purchaser's only remedy under this limited warranty, Company will furnish a replacement part to the licensed HVAC service provider, without charge for the part only, to replace any Product part that fails due to a manufacturing defect under normal use and maintenance. The Purchaser must pay for any and all shipping and handling charges and other costs of warranty service for the replacement part. If a Product part is not available, Company will, at its option, provide a free suitable substitute part or provide a credit in the amount of the then factory selling price for a new suitable substitute part to be used by the Purchaser towards the retail purchase price of a new Company product. Any new Product purchase shall be at Purchaser's sole cost and expense including, but not limited to, all shipping, removal, and installation costs and expenses.

REGISTRATION REQUIREMENTS: All Products must be properly registered online by the Purchaser within sixty (60) days after the Commencement Date to receive the registered limited warranty terms. To register online, go to:

<http://www.trane.com/Residential/For-Owners/Warranties> or

<http://www.americanstandardair.com/servicesupport/pages/warranty.aspx>

and click "Begin Online Registration." If a Purchaser does not register within this stated time period, the base limited warranty terms shall apply.

ELIGIBILITY REQUIREMENTS: The following items are required in order for the Products to be covered under this limited warranty:

- The Products must be in the same location where they were originally installed.
- The Products must be properly installed, operated, and maintained by a licensed HVAC service provider in accordance with the Product specifications or installation, operation, and maintenance instructions provided by Company with each Product. Failure to conform to such specifications and/or instructions shall void this limited warranty. Company may request written documentation showing the proper preventative maintenance.
- All Product parts replaced by Company under this limited warranty must be given to the servicing provider for return to Company.
- Air handlers, air conditioners, heat pumps, cased or uncased coils and stand-alone furnaces must be part of an Air Conditioning, Heating, and Refrigeration Institute rated and matched system or a specification in a Company provided bulletin or otherwise approved in writing by a Company authorized representative.

EXCLUSIONS: The following are not covered by this limited warranty:

- Labor costs including, but not limited to, costs for diagnostic calls or the removal and reinstallation of Products and/or Product parts.
- Shipping and freight expenses required to ship Product replacement parts.
- Failures, defects, or damage (including, but not limited to, any loss of data or property) caused by (1) any third party product, service, or system connected or used in conjunction with the Products; (2) any use that is not designed or intended for the Products; (3) modification, alteration, abuse, misuse, negligence, or accident; (4) improper storage, installation, maintenance, or operation including, but not limited to, operation of electrical equipment at voltages other than the range specified on the Product nameplate; (5) any use in violation of written instructions or specifications provided by Company; (6) any acts of God including, but not limited to, fire, water, storms, lightning, or earthquakes; or any theft or riots; or (7) a corrosive atmosphere or contact with corrosive materials such as, but not limited to, chlorine, fluorine, salt (provided that indoor and outdoor coils will only be covered if a Sea Coast Kit is installed), sulfur, recycled waste water, urine, fertilizers, rust, or other damaging substances or chemicals.
- Products purchased direct including, but not limited to, Internet or auction purchases and purchases made on an uninstalled basis.
- Cabinets or cabinet pieces that do not affect product performance, air filters, refrigerant, refrigerant line sets, belts, wiring, fuses, surge protection devices, non-factory installed driers, and Product accessories (unless otherwise specified).
- Increased utility usage costs.

REFRIGERANT POLICY: (1) **Manufacturer-Installed Refrigerant:** Beginning on January 1, 2010, R-22 refrigerant will no longer be used as a manufacturer-installed refrigerant as required by federal regulation. All Products with manufacturer-installed refrigerant will include R410-A refrigerant. Any and all expenses or costs associated with replacing Product parts that are not R-410A compatible will not be covered by the terms and conditions of this limited warranty. (2) **Non-Manufacturer installed Refrigerant:** For Products manufactured and sold by the Company without refrigerant, only manufacturer approved and genuine alternate refrigerants shall be used. The use of contaminated, counterfeit, non-genuine, or non-manufacturer approved alternate refrigerant will void this limited warranty. (3) **All Products:** Products include a liquid line filter drier which must be replaced when a compressor replacement is necessary. A suction line filter drier must be added for compressors defined as burnouts and failure to do so will void this warranty. Non-approved refrigerant and/or non-approved refrigerant system additives including, but not limited to dyes will void this limited warranty.

ADDITIONAL TERMS:

THIS LIMITED WARRANTY AND LIABILITY SET FORTH HEREIN ARE IN LIEU OF ALL OTHER WARRANTIES AND LIABILITIES, WHETHER IN CONTRACT OR IN NEGLIGENCE, EXPRESS OR IMPLIED, IN LAW OR IN FACT. THE IMPLIED WARRANTIES OF MERCHANTABILITY AND FITNESS FOR A PARTICULAR PURPOSE ARE LIMITED TO THE DURATION OF THE APPLICABLE PRODUCT WARRANTY. COMPANY DOES NOT AUTHORIZE ANY PERSON TO CREATE FOR IT ANY OBLIGATION OR LIABILITY IN CONNECTION WITH THE PRODUCTS.

NOTWITHSTANDING ANYTHING IN THIS LIMITED WARRANTY TO THE CONTRARY, COMPANY SHALL NOT BE LIABLE FOR ANY INCIDENTAL, CONSEQUENTIAL, INDIRECT, SPECIAL AND/OR PUNITIVE DAMAGES, WHETHER BASED ON CONTRACT, WARRANTY, TORT (INCLUDING, BUT NOT LIMITED TO, STRICT LIABILITY OR NEGLIGENCE), PATENT INFRINGEMENT, OR OTHERWISE, EVEN IF ADVISED OF THE POSSIBILITY OF SUCH DAMAGES. COMPANY'S MAXIMUM LIABILITY HEREUNDER IS LIMITED TO THE ORIGINAL PURCHASE PRICE OF THE PRODUCTS.

No action arising out of any claimed breach of this limited warranty may be brought by a Purchaser more than one (1) year after the cause of action has arisen.

This limited warranty gives you specific legal rights, and you may also have other rights as otherwise permitted by law. If this Product is considered a consumer product, please be advised that some local laws do not allow limitations on incidental or consequential damages, how long a warranty lasts based on registration, or how long an implied warranty lasts, so that the above limitations may not fully apply. Refer to your local laws for your specific rights under this limited warranty.

Residential Systems
6200 Troup Highway, Tyler, TX 75707
Attn: Customer Relations

Or visit our website at www.trane.com or www.americanstandardair.com

GW-658-4212

Table 1A: Warranty Time Periods

COVERAGE TERMS FOR RESIDENTIAL APPLICATIONS: Pursuant to the Trane U.S., Inc. ("Company") limited warranty terms and conditions, the following Products are covered for the base time periods as stated below ("Base Limited Warranty period"). If registered, the Base Limited Warranty Periods for certain products will be extended as stated below ("Registered Limited Warranty Period").

CONTROLS: *CONT200,*CONT401,*CONT402, *CONT600 &*CONT602

Base Limited Warranty Period: one (1) year | Registered Limited Warranty Period: five (5) years

CONTROLS: *ZEMT500, CONT624, *CONT800,*CONT802,*CONT803,*CONT 824, *CONT900, *ZONE940, *ZONE950

Base Limited Warranty Period: five (5) years | Registered Limited Warranty Period: ten (10) years

ZONING PRODUCTS: *ZONE950, *ZONE940, *ZONE930, ZZONEPNLAC52Z, ZZONEEXPAC52Z, ZZSENSAL0400, BAYSEN01ATEMPA, BAY24VRP, ZDAMPRD, ZDAMPSM, ZDAMPBM, ZDAMPRR

Base Limited Warranty Period: five (5) years | Registered Limited Warranty Period: ten (10) years

HUMIDIFIERS: *HUMD200, *HUMD300 & *HUMD500

Base Limited Warranty Period: five (5) years | Registered Limited Warranty Period: ten (10) years

ENERGY RECOVERY VENTILATOR (ERV): *ERVR100, *ERVR200 & *ERVR300

Base Limited Warranty Period: five (5) years | Registered Limited Warranty Period: ten (10) years

AIR CLEANERS: TFD & AFD

Base Limited Warranty Period: five (5) years | Registered Limited Warranty Period: ten (10) years

VARIABLE SPEED OIL FURNACE: *HV-V, *LF-V, *LR-V,*DF-V

Base Limited Warranty Period: Parts- five (5) years, Heat Exchanger - twenty (20) years
Registered Limited Warranty Period: Parts - ten (10) years, Heat Exchanger - Lifetime

NON-VARIABLE SPEED OIL FURNACE: *HV, *LF, *LR,*DF

Base Limited Warranty Period: Parts- five (5) years, Heat Exchanger - twenty (20) years
Registered Limited Warranty Period: Parts - five (5) years, Heat Exchanger - Lifetime

SPECIFIC TERMS FOR COMMERCIAL APPLICATIONS:

Base Limited Warranty Period Applies for all controls, zoning products, humidifiers and ERV's
All Oil Furnaces: Parts - one (1) year, Heat Exchanger - twenty (20) years

*(First letter may be A or T)

6200 Troup Highway

Tyler, TX 75707

© 2013 Trane

24

18-HD71D1-3

11/13