

Installer's Guide

ZZSENSAL0400AA

Remote Indoor Temperature Sensor

For use with these Controls: *CONT402, *CONT624, *CONT824, *CONT850, *ZONE950

ALL phases of this installation must comply with NATIONAL, STATE AND LOCAL CODES

APPLICATION

This Wall Mount Temperature Sensor is used with the *CONT402, *CONT624, *CONT824, *CONT850 and *ZONE950.

SPECIFICATIONS

Operating Ambient Temperature Range:

20° to 120°F (-6.7° to 48.9°C).

Display Range:

20° to 120°F (-6.7° to 48.9°C).

Sensor Accuracy:

+/- .5°F at 75°F

Operating Relative Humidity:

5% to 90% non-condensing.

Finish: White.

Dimensions in in. (mm):

1.54 (39) wide x 1.93 (49) high x .745 (19) deep.

Storage Temperature:

-40° to 140°F (-40° to 60°C)

INSTALLATION

When Installing this Product...

1. Read these instructions carefully. Failure to follow them could damage the product or cause a hazardous condition.
2. Check the ratings given in the instructions and on the product to make sure the product is suitable for your application.



CAUTION

Disconnect power supply before connecting wiring.

Failure to do so may cause equipment damage.

3. Installer must be a trained, experienced service technician.
4. After installation is complete, check out product operation as provided in these instructions.

Location and Mounting (Fig. 2)



CAUTION

If the Remote Indoor Temperature Sensor fails, control reverts to the on-board temperature sensor. Therefore, the Comfort Control must be installed in the conditioned space.

1. Choose a location for mounting the Sensor on an inside wall about 5 ft. (1.5m) above the floor.
2. Be sure cable distance between the Sensor and the Comfort Control is less than 200 feet.

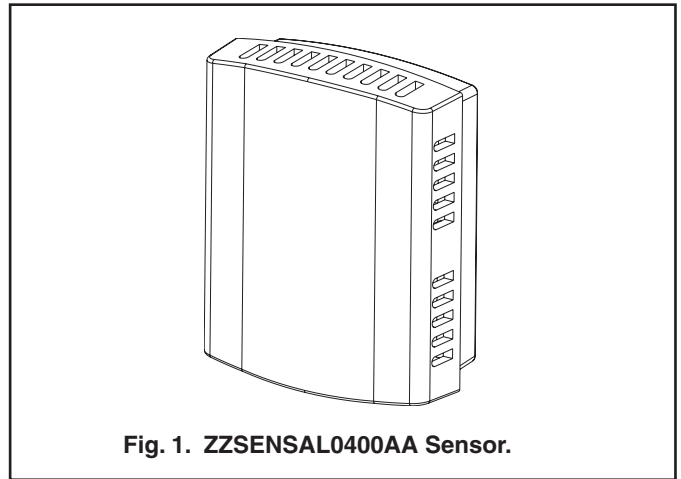
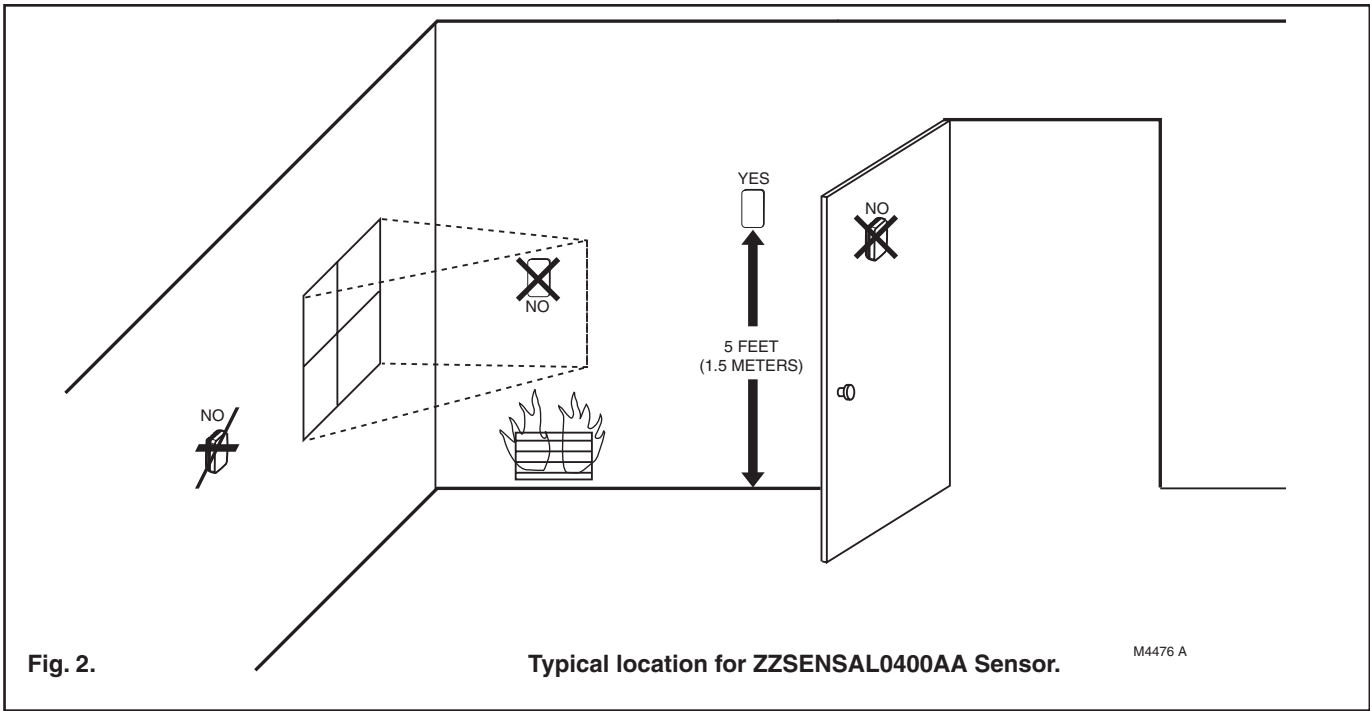

Fig. 1. ZZSENSAL0400AA Sensor.

3. Make sure there is good air circulation at average temperature at the chosen location. Avoid the following locations because they can introduce errors in sensor measurements. See Fig. 2.
 - a. Hot areas caused by:
 - (i) Concealed pipes or ducts.
 - (ii) Drafts from fireplaces or other heat sources.
 - (iii) Convection or radiant heat from the sun or electrical equipment.
 - b. Cold areas caused by:
 - (i) Concealed pipes or ducts.
 - (ii) Drafts from windows and doors.
 - (iii) Unheated areas on the other side of the wall location.
 - c. Dead air areas:
 - (i) Behind doors, furniture and curtains.
 - (ii) In corners and alcoves.
4. Remove remote indoor sensor cover by grasping the cover at the top and the bottom and gently pulling it straight off the subbase. Position and level the subbase (for appearance only). Device functions correctly even when not level.
5. Use a pencil to mark the wiring opening hole. Remove the subbase from the wall and drill one hole in the wall for the wiring opening.
6. Run wire cable to the wiring opening hole at the selected wall location. Pull approximately three inches of wire through the wiring opening in the wall. 18-gauge thermostat wire is recommended.
7. Position and level the subbase on the wall with the thermostat wire protruding through the wiring opening hole of the subbase. Slide the subbase a short distance up the wall until the thermostat wire rests against the bottom edge of the wire opening hole in the subbase



adjacent to the top edge of the printed circuit board and wiring connector. This should result in a sufficient amount of wall material left between the top mounting and wiring opening holes.

8. Use a pencil to mark both mounting holes. Remove the subbase from the wall and drill two holes in the wall for mounting. Gently tap anchors (provided) into the drilled mounting holes until flush with the wall.
9. Position and level the subbase on the wall with the thermostat wire through the wiring opening hole of the subbase and with the mounting holes aligned with the two anchors. Mount the subbase on the wall using the provided mounting screws.

Wiring (Fig. 3,4,5)

Electrical Interference (Noise) Hazard. Can cause erratic system operation.

Keep wiring at least one foot away from large inductive loads such as motors, line starters, lighting ballasts and large power distribution panels.

IMPORTANT

Erratic temperature readings from a sensor can occur as a result of any of the wiring practices described below. Avoid these practices to assure correct operation.

- Do not route temperature sensor wiring with building power wiring, next to control contactors or near light dimming circuits, electric motors or welding equipment.
- Avoid poor wiring connections.
- Avoid intermittent or missing building earth ground.

⚠ CAUTION

Disconnect power supply before connecting wiring. Failure to do so may cause equipment damage.

Wiring must comply with applicable codes, ordinances and regulations.

1. Strip 1/4-in. of insulation off two wires. Bend the bare wire

downward 90 degrees to easily insert into the terminal block.

2. Loosen terminal block screws. Insert two wires into the terminal block.
3. Securely tighten each terminal block screw.
4. Push excess wire back into the hole.
5. Plug the hole with nonflammable insulation to prevent drafts from affecting the remote indoor sensor.
6. Install the remote indoor sensor cover onto the subbase by gently pressing the cover over the subbase until the tabs snap into place.

OPERATION

Once installed and the Comfort Control Installer Setup is complete, the remote inside temperature is displayed on the

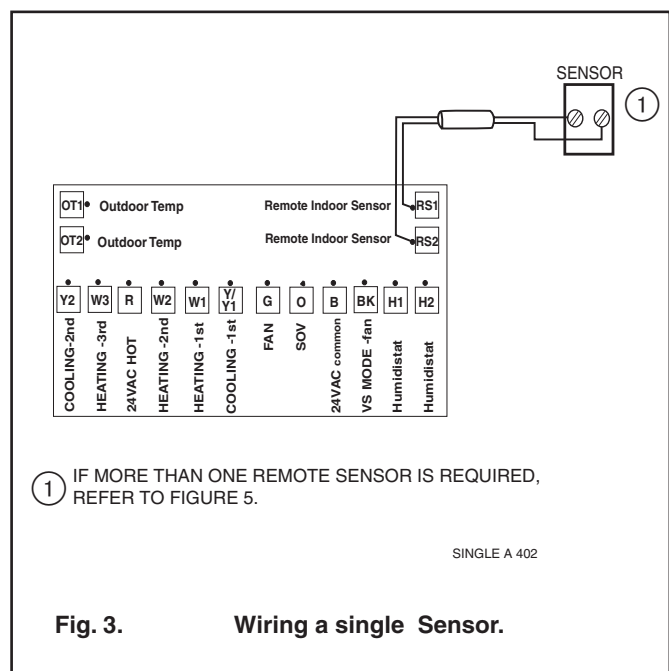

- ① IF MORE THAN ONE REMOTE SENSOR IS REQUIRED, REFER TO FIGURE 5.

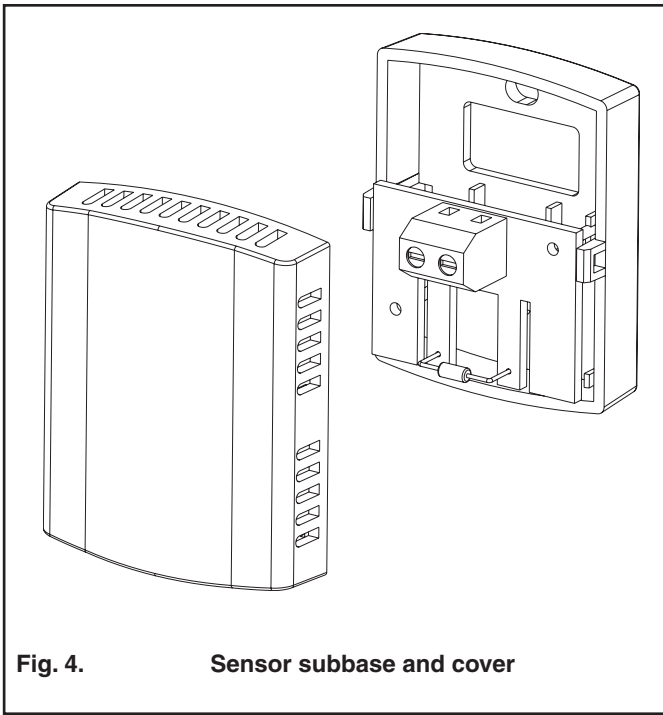

Fig. 4. Sensor subbase and cover

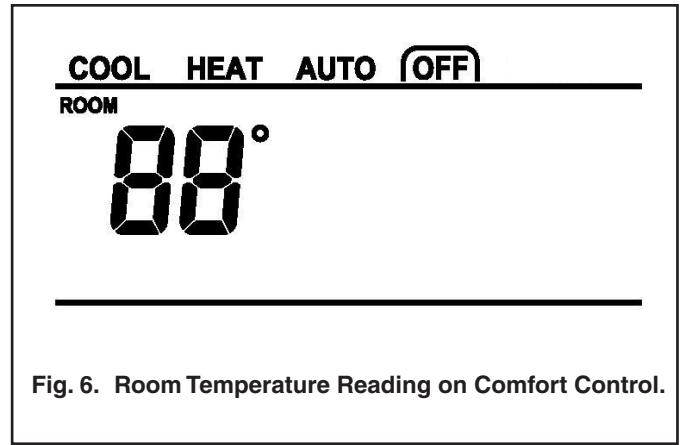

Fig. 6. Room Temperature Reading on Comfort Control.

Comfort Control Home Screen as the Room Temperature. See Fig. 6.

The Remote Indoor Temperature Sensor converts room temperature to a resistance that the Comfort Control can interpret. The Sensor has a negative temperature coefficient (NTC), which means that resistance decreases as the temperature increases. See Table 1.

The Sensor can be used to provide one remote input (see Fig. 3) or as a temperature averaging network with multiple Sensors connected, as shown in Fig. 5.

CHECKOUT

For best results, leave the Remote Indoor Temperature Sensor at a stable room ambient for a minimum of twenty minutes before taking a resistance measurement.

With an accurate thermometer ($\pm 1^\circ\text{F}$ [0.5°C]) measure the temperature at the sensor location, allowing time for the thermometer to stabilize before reading.

To verify sensor resistance, remove one wire from one of the Sensor wiring terminals. Use an ohmmeter to measure the resistance across the sensor. Then verify the sensor accuracy with the temperature/resistance in Table 1 on page 4. Reinstall the removed wire.

TROUBLESHOOTING

If the remote indoor temperature sensor fails, control reverts to the on-board temperature sensor. Therefore, the comfort control must be installed in the conditioned space.

CALIBRATION

The Remote Indoor Temperature Sensor is calibrated at the factory and cannot be recalibrated in the field.

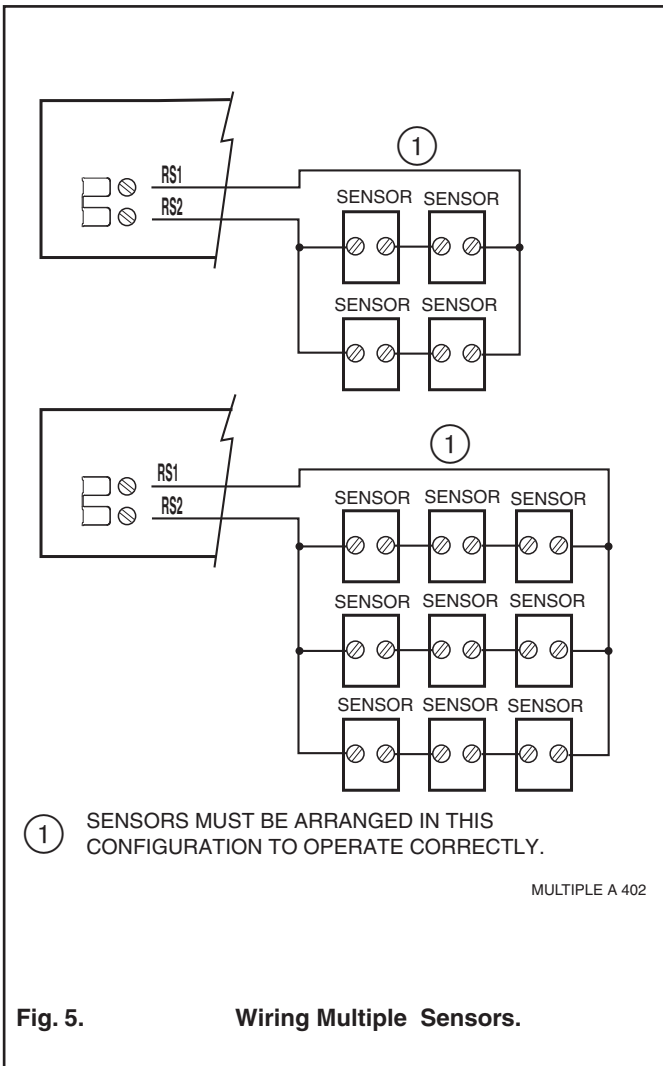

Fig. 5. Wiring Multiple Sensors.

Installer's Guide

The Remote Indoor Temperature Sensor response can be calibrated at the Comfort Control. See the Installer's Guide or User's Manual for details.

Table 1. Sensor Resistance at Room Temperature.

ROOM TEMPERATURE		OHMS OF RESISTANCE
°F	°C	
40	4.4	26.1k
42	5.6	24.7k
44	6.7	23.4k
46	7.8	22.1k
48	8.9	21.0k
50	10.0	19.9k
52	11.1	18.9k
54	12.2	17.9k
56	13.3	17.0k
58	14.4	16.1k
60	15.6	15.3k
62	16.7	14.5k
64	17.8	13.8k
66	18.9	13.1k
68	20.0	12.5k
70	21.1	11.9k
72	22.2	11.3k
74	23.3	10.8k
76	24.4	10.2k
78	25.6	9.8k
80	26.7	9.3k
82	27.8	8.9k
84	28.9	8.5k
86	30.0	8.1k
88	31.1	7.7k
90	32.2	7.3k
92	33.3	7.0k
94	34.4	6.7k
96	35.6	6.4k
98	36.7	6.1k
100	37.8	5.8k

Trane
6200 Troup Highway
Tyler, TX 75707

For more information contact
your local dealer (distributor)

Since the manufacturer has a policy of continuous product and product data improvement, it reserves the right to change design and specifications without notice.