

SERVICE INSTALLER'S GUIDE

18-GJ84D1-1A-EN EMI/EFI Air Handler Kit

ALL phases of this installation must comply with NATIONAL, STATE AND LOCAL CODES

Model:

BAYAHEMIKIT001A

Used With:

EMI/EFI Air Handler Motor

IMPORTANT — This Document is customer property and is to remain with this unit.
Please return to service information pack upon completion of work.

⚠ WARNING DISCONNECT POWER BEFORE SERVICING

BAYAHEMIKIT001A KIT COMPONENTS

See Figure 1

EMI Kit BAYAHEMIKIT001A			
ITEM #	Part Number	Part Description	Qty
1	D806151	TEM Male/Female Harness	1
2	D806153	TAM / GAM Male/Female Harness	1
3	D806180P01	In-line EMI Filter (Schaffner)	1
4	D806121P01	Bracket, In-line EMI Filter	1
5	D804964P08	Gasket for back of Bracket	1
6	D806181P01	Ferrite Beads	2
7	D905103P01	#10 x 3/8" Cutting Screws	2
8	D804271P01	#8 x 1/2" Screws	2
9	D803499P01	#8 x 1/2" Cutting Screws	2
10	C107736P07	Cable Ties	4
11	18-GJ84D1-1A-EN	Installation Instructions	1
12	D806182P01	Wiring Diagram	1
13	D806182P02	Wiring Diagram	1
14	D806182P03	Wiring Diagram	1

APPLICATION:

The EMI/EFI Air Handler Kit may be used on any air handler unit with a CTM or variable speed motor. This Kit helps to reduce the emitted noise generated when running these motors.

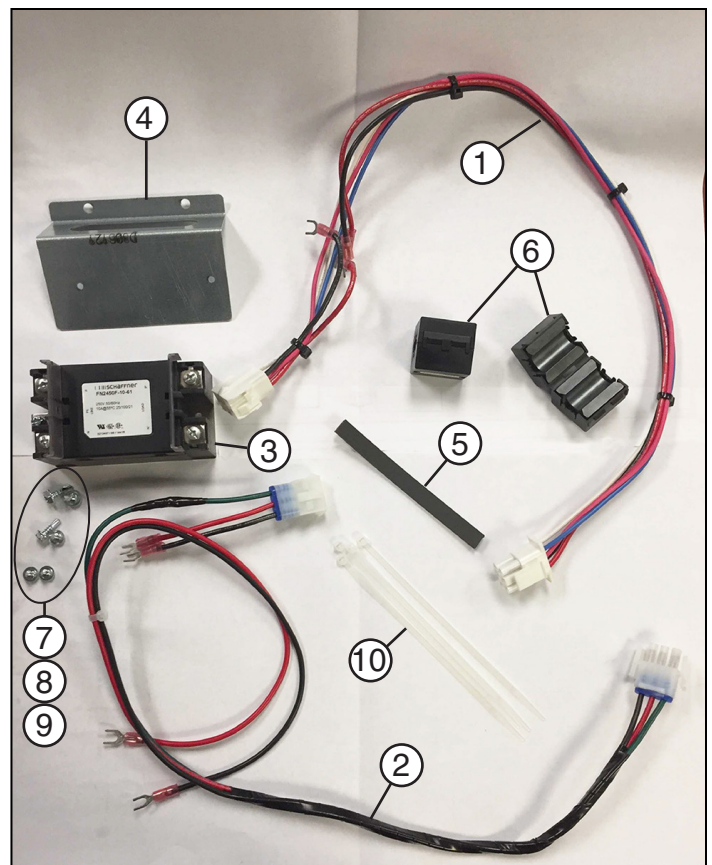

FIGURE 1

⚠ WARNING

The cabinet must have an uninterrupted or unbroken ground according to National Electrical Code, ANSI/NFPA 70 - "latest edition" and Canadian Electrical Code, CSA C22.1 or local codes to minimize personal injury if an electrical fault should occur.

Failure to follow this warning could result in an electrical shock, fire, injury, or death.

⚠ WARNING

Disconnect power to the unit before removing the blower or coil door.

Failure to follow this warning could result in personal injury from moving parts.

⚠ WARNING

Prevent all wires from touching any hot surfaces. Failure to follow this warning could result in dangerous operation, serious injury, death or property damage.

EMI FILTER INSTALL INSTRUCTIONS FOR TAM / GAM AIR HANDLERS

1. Mount the EMI filter (Item 3) to the EMI filter bracket (Item 4) using two #8 screws (Item 8). See Figure 2.

2. Apply the gasket (Item 5) to the back bottom edge of the bracket. See Figure 3.

3. Mount the EMI filter and bracket to the blower shelf using two #10 cutting screws (Item 7).

NOTE: Make sure to align the left edge of the bracket with the left edge of the blower housing. (See Figure 4)

4. Installing Ferrite Bead (Item 6) on a variable speed motor. Place one ferrite bead on motor power wires. There should be at least one loop made in the power wires, so the wires pass through the ferrite bead twice. See Figure 5.

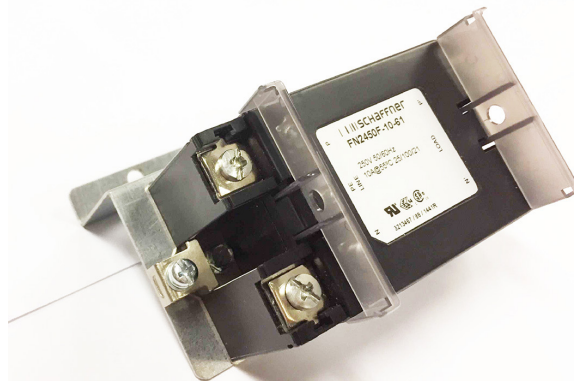

FIGURE 2



FIGURE 3

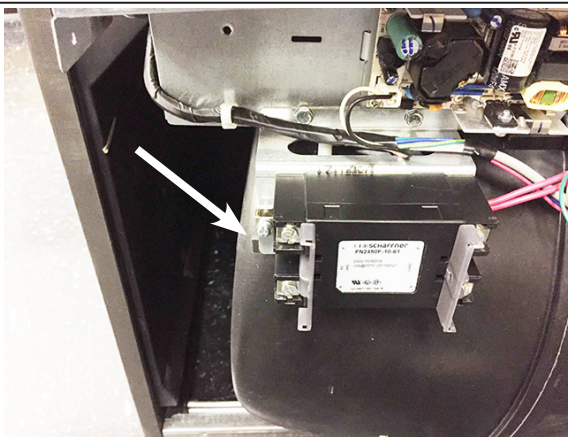

FIGURE 4

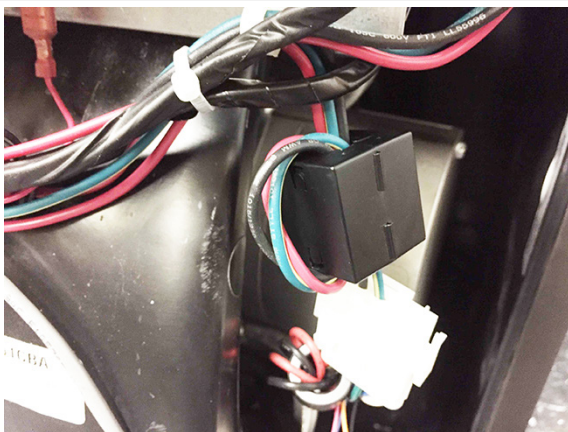

FIGURE 5

5. Installing Ferrite Beads (Item 6) on a CTM motor. Place one ferrite bead on motor power wires. There should be at least one loop made in the power wires, so the wires pass through the ferrite bead twice. See Figures 6 and 7.

NOTE: *The black tape wrap may need to be cut to have enough wire to make the loops.*

OR

6. For units with a CTM motor, place a second ferrite bead on the low voltage wires. There should be at least one loop made in the low voltage wires, so the wires pass through the ferrite bead twice. See Figure 7.

7. Disconnect the 3 pin connector between the blower motor and the power supply. Pull the harness out of the blower deck slot and back in front of the blower. See Figures 8 and 9.

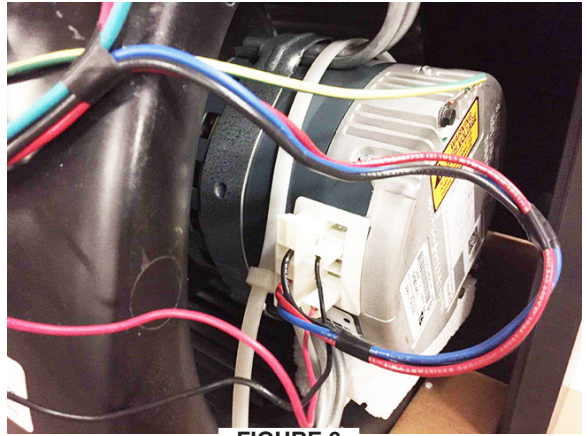

FIGURE 6

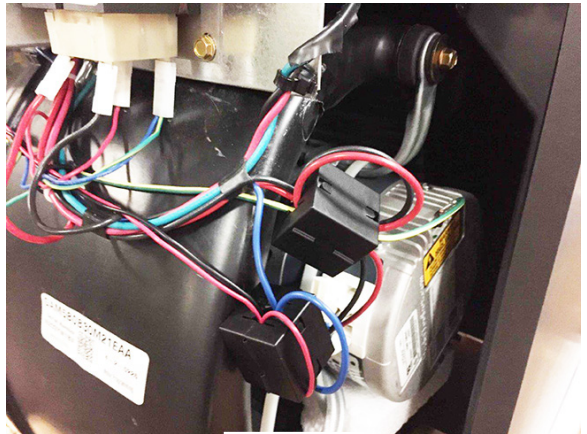

FIGURE 7

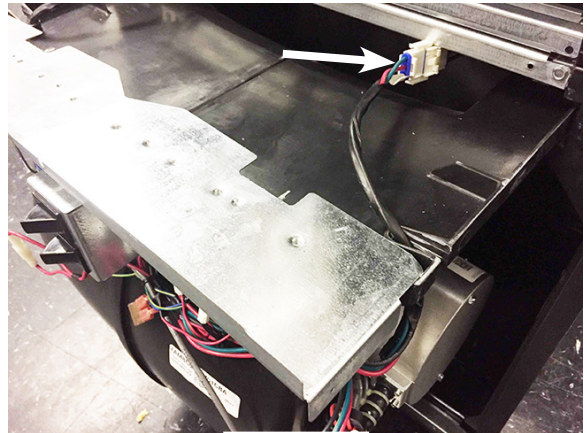

FIGURE 8

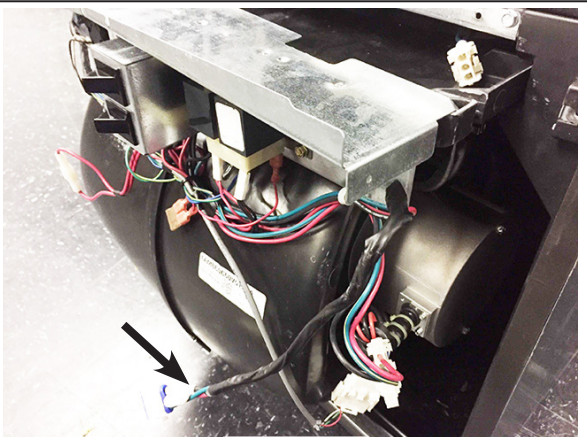
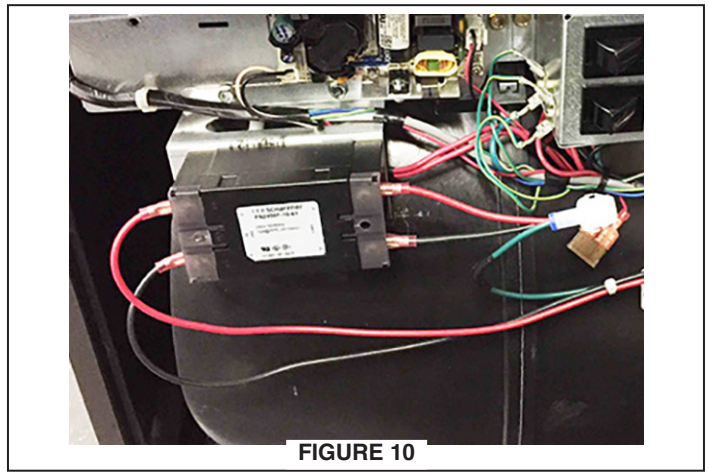
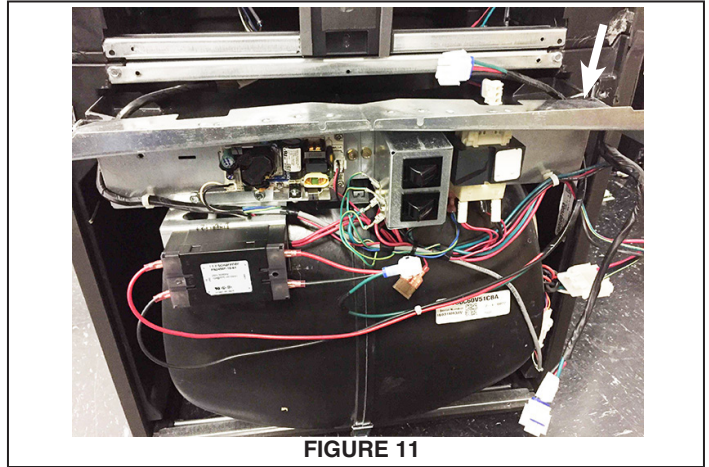

FIGURE 9

8. Connect the included TAM / GAM harness (Item 2) to the line side and load side of the EMI filter, as shown in Figure 10. The shorter leads with the female plug will be on the load side.



9. Make sure the new harness is secured in the blower slot. Connect the male 3 pin connectors to the power supply above the blower in the coil cabinet. Connect the female 3 pin connector from the EMI filter to the blower motor harness that was pulled out of the slot to the front of the blower.



10. Use the included cable ties to secure the harness.

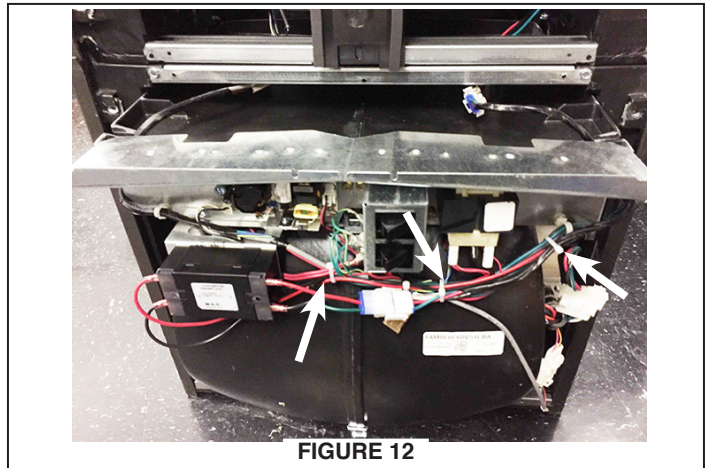

EMI FILTER INSTALL INSTRUCTIONS FOR TEM AIR HANDLERS WITHOUT HEATERS

1. Locate the EMI Filter (Item 3) on the left side of the heater barrier. See Figure 13.
 2. Use the two included #8 cutting screws (Item 9) to mount the EMI filter in place.
-
3. Installing Ferrite Bead (Item 6) on a variable speed motor. Place one ferrite bead on motor power wires. There should be at least one loop made in the power wires, so the wires pass through the ferrite bead twice. See Figure 14

OR

4. Installing Ferrite Beads (Item 6) on a CTM motor. Place one ferrite bead on motor power wires. There should be at least one loop made in the power wires, so the wires pass through the ferrite bead twice. See Figures 15 and 16.

NOTE: *The black tape wrap may need to be cut to have enough wire to make the loops.*

5. For units with a CTM motor, place a second ferrite bead on the low voltage wires. There should be at least one loop made in the low voltage wires, so the wires pass through the ferrite bead twice. See Figure 16.



FIGURE 13

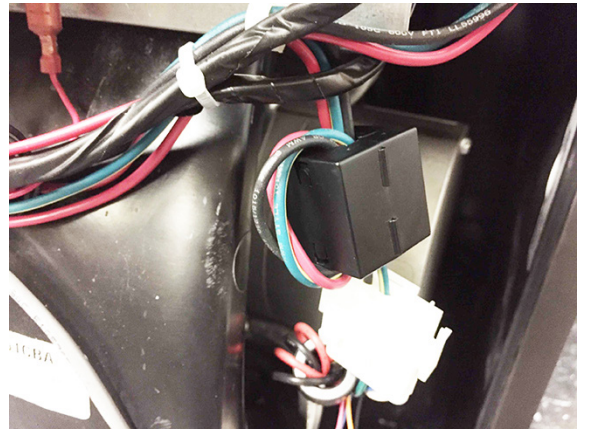

FIGURE 14



FIGURE 15

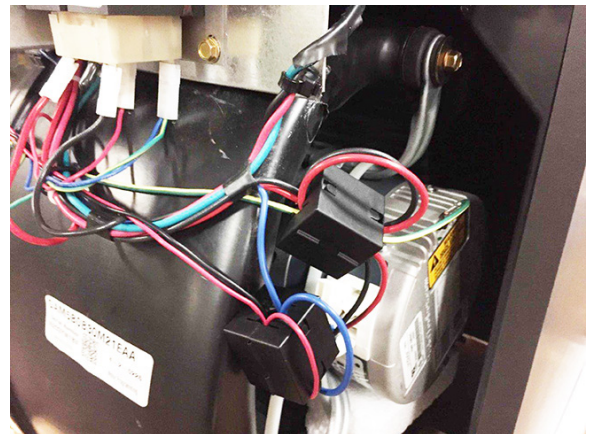

FIGURE 16

6. Disconnect the incoming power from the 2 wire unit harness at the wire nut.
7. Connect the incoming power wires to the line side of the EMI filter. See Figure 17.
8. Connect the 2 wire unit harness to the load side of the EMI filter. See Figure 17.

9. Use the included cable ties to secure the harness, as needed.

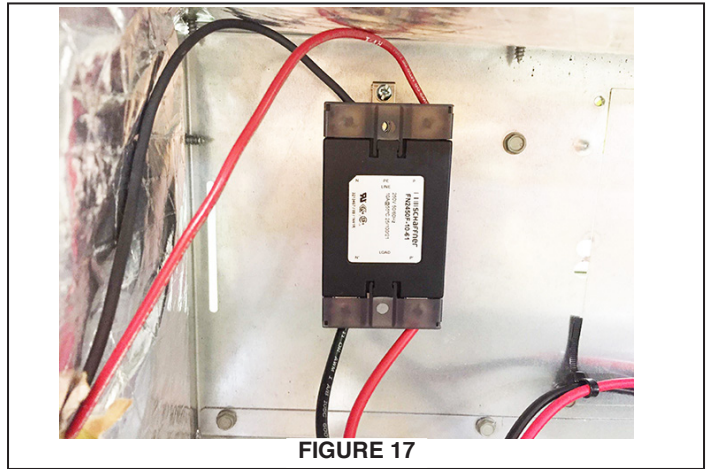

FIGURE 17

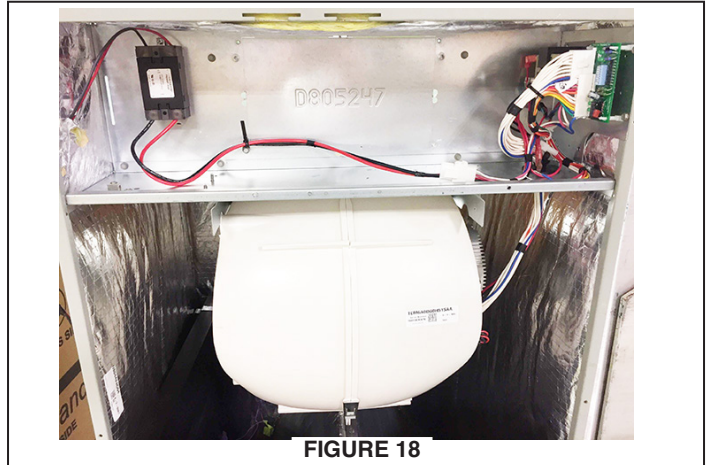

FIGURE 18

EMI FILTER INSTALL INSTRUCTIONS FOR TEM AIR HANDLERS WITH HEATERS

1. Locate the EMI Filter (Item 3) on the left side of the heater barrier. See Figure 19.
2. Use the two included #8 cutting screws (Item 9) to mount the EMI filter in place.
3. Installing Ferrite Bead (Item 6) on a variable speed motor. Place one ferrite bead on motor power wires. There should be at least one loop made in the power wires, so the wires pass through the ferrite bead twice. See Figure 20.

OR

4. Installing Ferrite Beads (Item 6) on a CTM motor. Place one ferrite bead on motor power wires. There should be at least one loop made in the power wires, so the wires pass through the ferrite bead twice. See Figures 21 and 22.

NOTE: *The black tape wrap may need to be cut to have enough wire to make the loops.*

5. For units with a CTM motor, place a second ferrite bead on the low voltage wires. There should be at least one loop made in the low voltage wires, so the wires pass through the ferrite bead twice. See Figure 22.



FIGURE 19

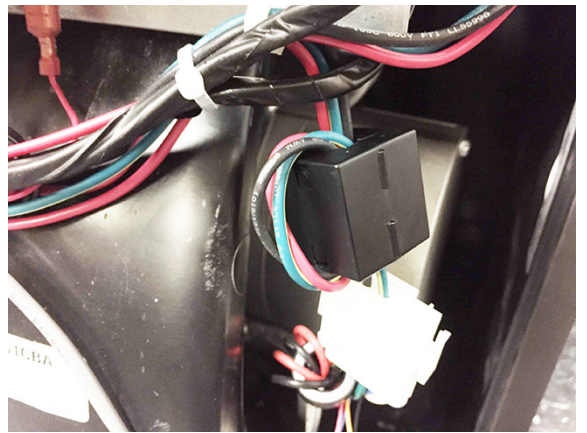

FIGURE 20

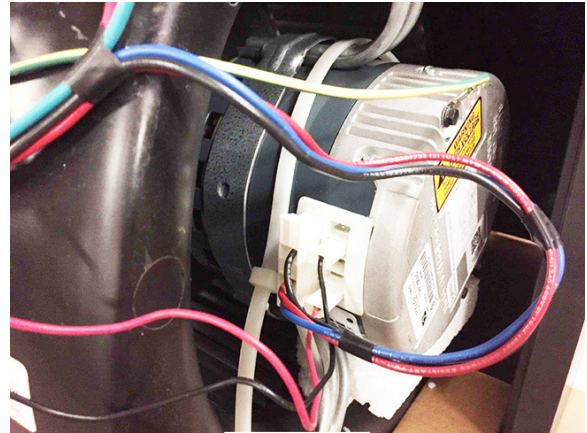

FIGURE 21

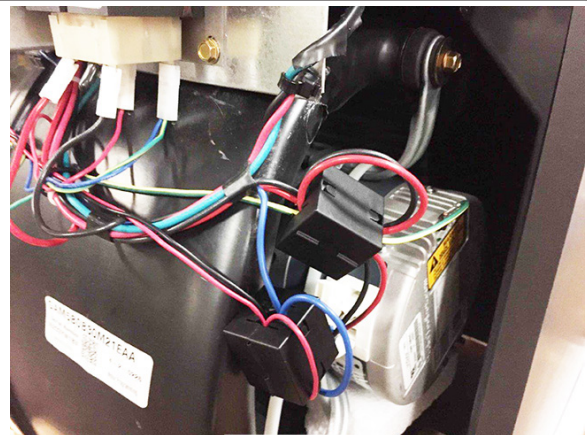
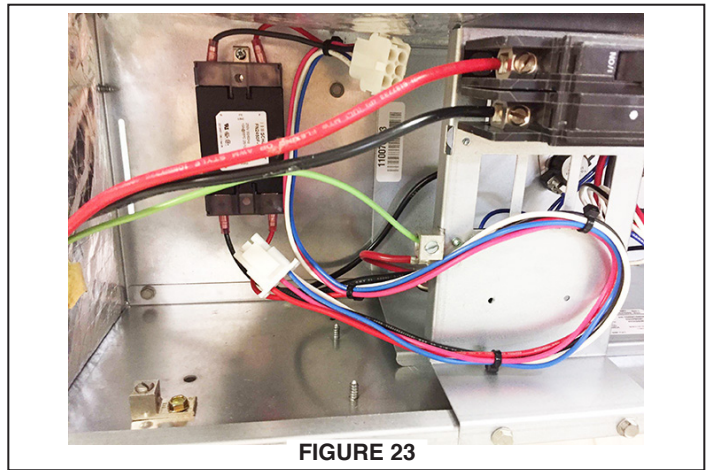
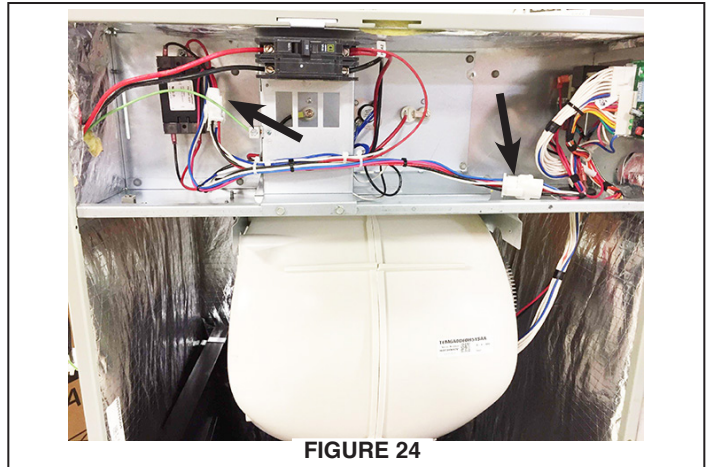

FIGURE 22

6. Connect the TEM wire harness (Item 1) to the EMI filter for both the Line side and the Load side. The shorter leads will be attached on the line side of the EMI filter. See Figure 23.



7. Disconnect the 6 pin connector harness between the line heater power and the unit controls.
8. Take the male 6 pin connector and plug it into the EMI filter harness female connector on the line side. See Figure 24.
9. Take the female 6 pin connector and plug it into the EMI filter harness male connector on the load side. See Figure 24.



10. Use the included cable ties to secure the harness. See Figure 25.
11. Place the EMI kit wiring diagram label next to the existing wiring diagram. See Figures 26 and 27.

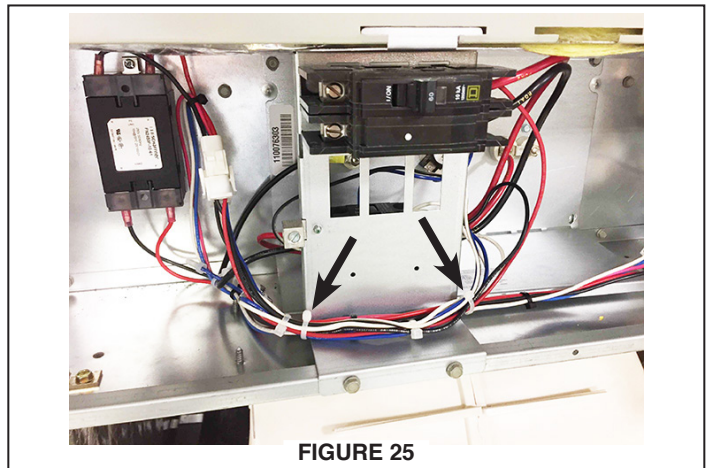

NOTE: Place the appropriate EMI kit wiring diagram label next to the existing wiring diagram on the unit for future reference.

FIGURE 26 Wiring Diagrams

D806182P01

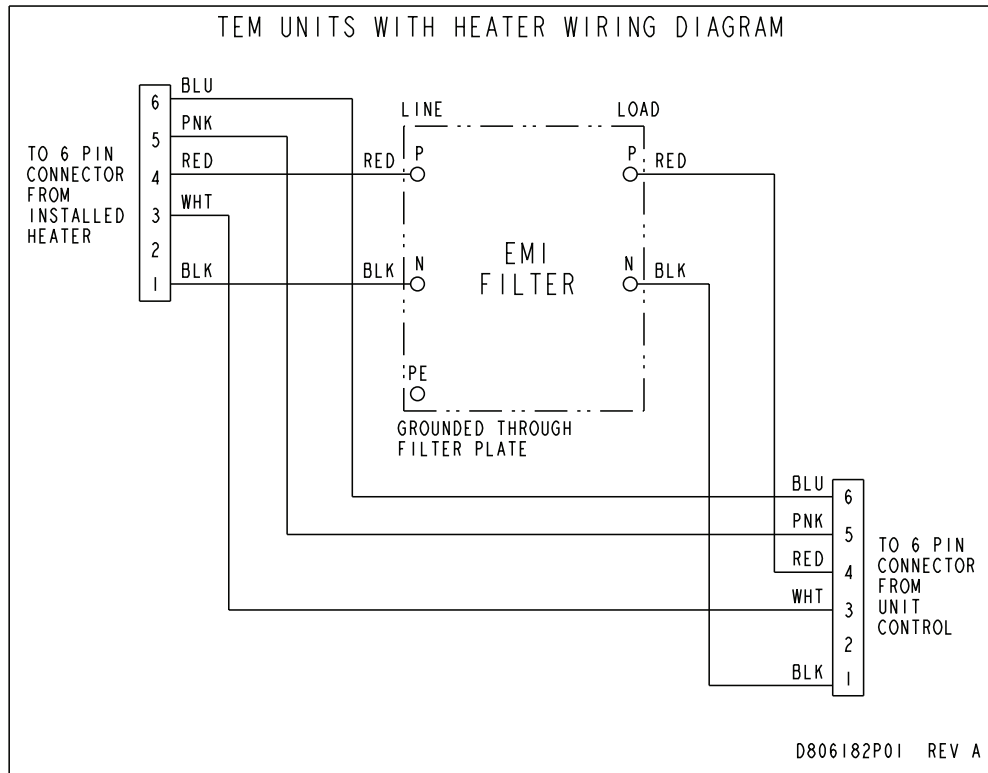

D806182P02

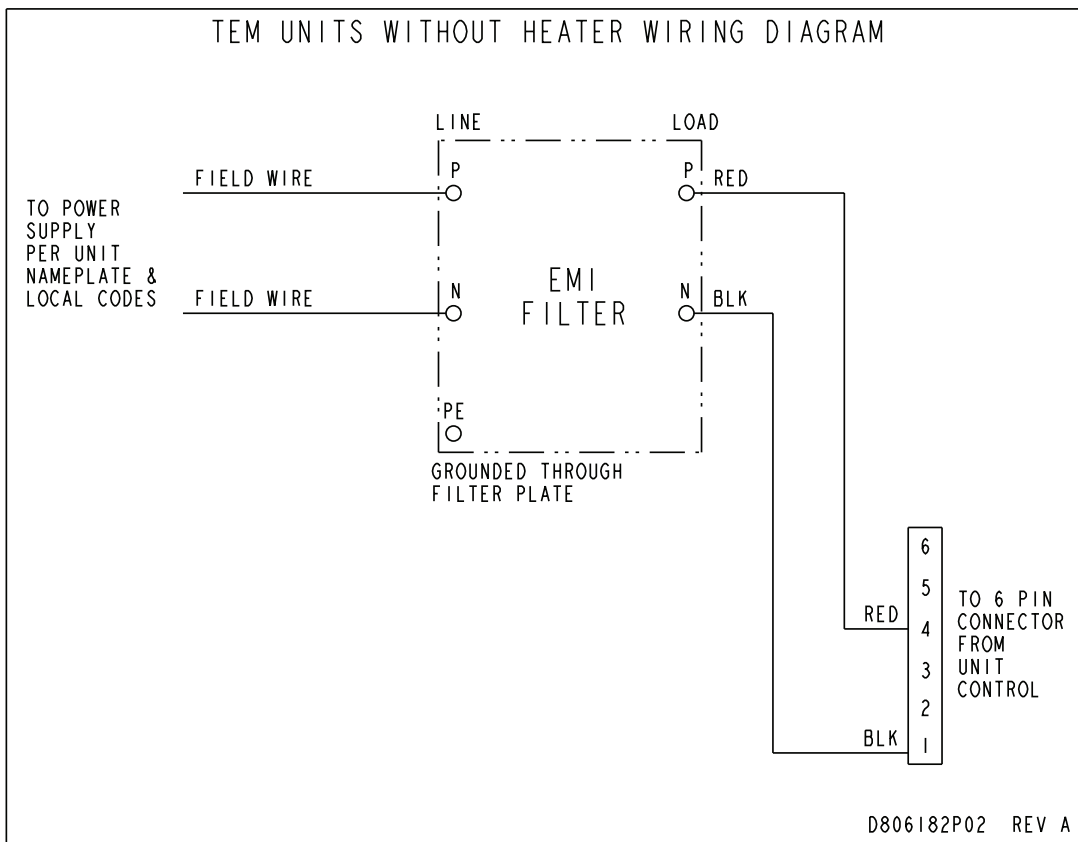
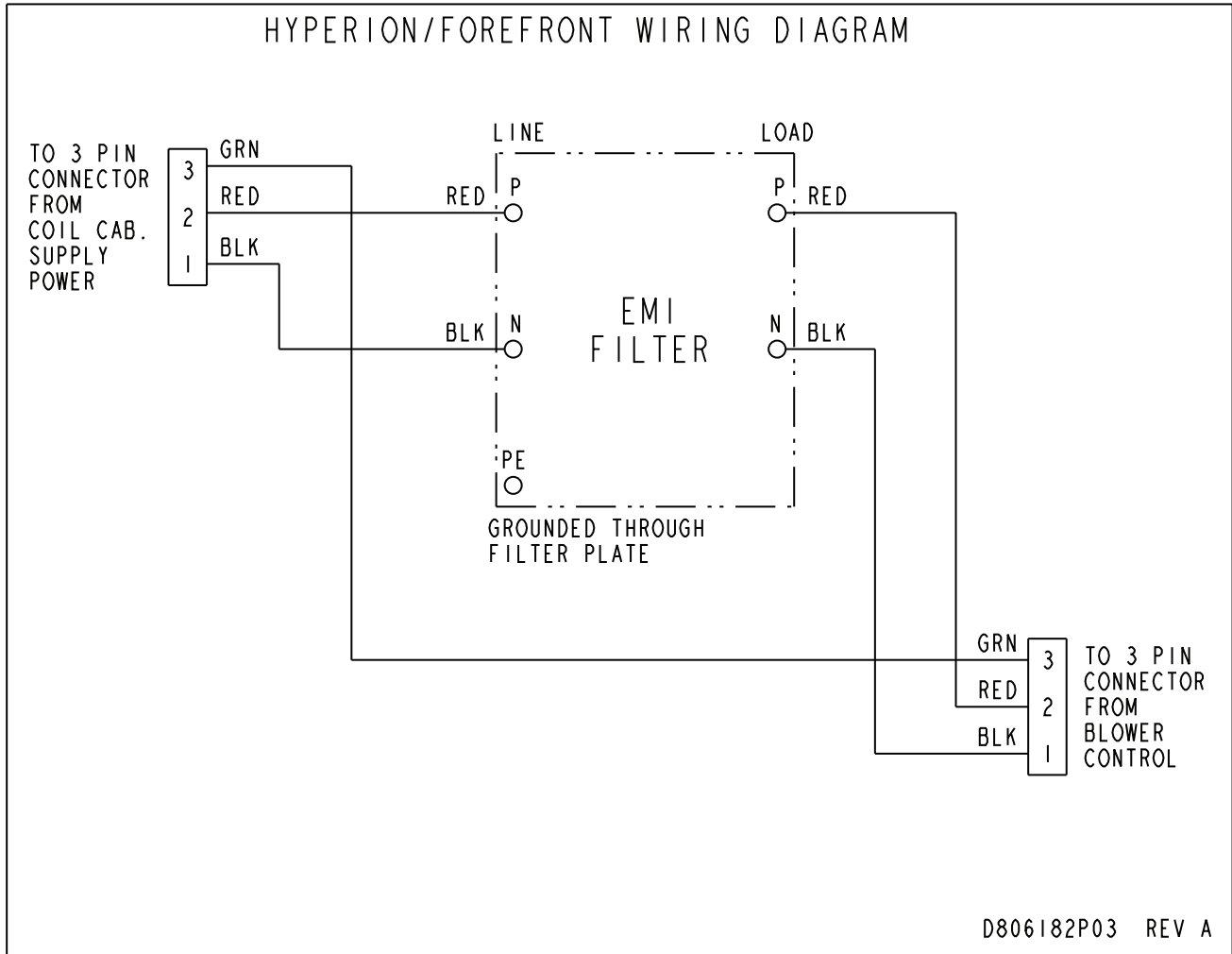

FIGURE 27 Wiring Diagrams (continued)

D806182P03 (TAM / GAM)



About Trane and American Standard Heating and Air Conditioning

Trane and American Standard create comfortable, energy efficient indoor environments for residential applications. For more information, please visit www.trane.com or www.americanstandardair.com

The manufacturer has a policy of continuous data improvement and it reserves the right to change design and specifications without notice. We are committed to using environmentally conscious print practices.