

INSTALLER'S GUIDE

18-GJ53D1-5A-EN

ALL phases of this installation must comply with NATIONAL, STATE AND LOCAL CODES

Coil TXV Kit:

BAYATXV1836C
BAYATXV4248C
BAYATXV6060C
BAYATXV6161C

Fits Models:

Hyperion™,
ForeFront™, and
TEM Air Handlers

IMPORTANT— This document is customer property and is to remain with this unit. Please return to service information pack upon completion of work.

General Information

The Coil TXV Kit is intended only for use with the specific models of the GAM, TEM, GAF, and GAT Air Handlers.

The Coil Thermostatic Expansion Valve (TXV) Kit is used to convert an R-410A application to an R-22 application.

NOTE: The TXV type must always match the refrigerant type listed on the name plate of the outside unit.

Kit Identification

Confirm the Coil TXV Kit type is approved to be used with an indoor model. See Table 1 to verify proper kit and product model number.

Inspection

Check carefully for any shipping damage. Any damage must be reported to, and claims made against the transportation company immediately. Any missing parts should be reported to your supplier at once and replaced with authorized parts only.

Coil TXV Kit Contents

This kit is used to convert an air handler to R-22 refrigerant.

Open and inspect contents for damage or missing items.

Each kit contains:

No.	Qty	Description
1	1	R-22 Expansion Valve
2	2	Teflon® O-ring
3	1	R-22 Caution Label
4	1	Installer's Guide (Not shown)
5	1(2)	Bulb Insulation
6	1(2)	Cable Tie
7	1	Liquid Tube Assembly*
8	1	Nut*
9	1	Sensing Bulb Strap
10	1(2)	Push-in Cable Tie

* Not included in BAYATXV6060C. Use existing mechanical inlet tube.
Note: Items in parenthesis are quantities in BAYATXV6161 kit only.

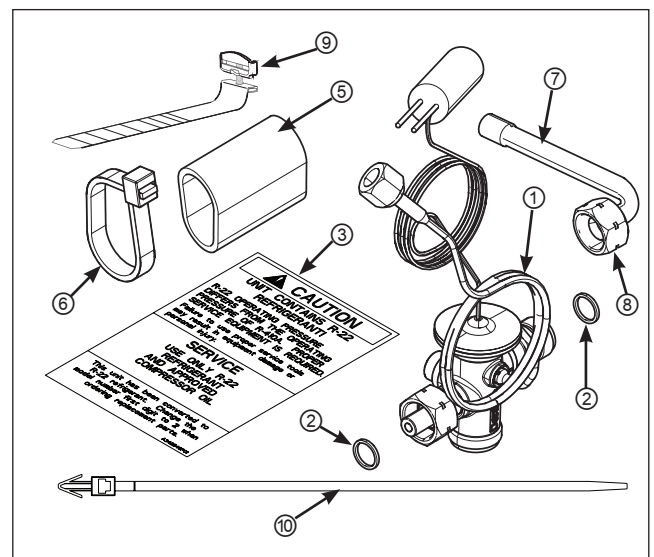

Figure 1

Installation Instructions

1. If air handler has never been installed go to Step 2.
If air handler has been previously installed, recover system charge or “pump-down” system charge into the condensing unit complying with EPA regulations.

NOTE: Minimize the amount of movement of the liquid and distributor tubes to prevent work hardening.

2. Remove the sensing bulb from the suction line manifold by removing the clamp.
3. Using a back-up wrench, loosen mechanical fittings on TXV.
4. Using a back-up wrench, loosen the external equalizing coupling.

NOTE: Remove the existing Teflon O-rings from the existing flow control assembly. O-rings may be attached to the TXV or the fittings.

5. DO NOT oil threads. To install the Coil TXV, install one O-ring over the Distributor Fitting (Figure 2). Install the other O-ring over the Liquid Line Fitting (Figure 3) and connect the adapters by hand to ensure proper mating of threads. Tighten until bodies “bottom” or a definite resistance is felt. The valve will only fit in one direction of flow. Use a back-up wrench and tighten an additional 1/4 turn. Wrap supplied push-in cable tie around TXV then insert cable tie barb into coil housing hole.

IMPORTANT: Correct tightening of the couplings is very important. Under- or over-tightening may result in a coupling leak.

6. Install the Equalizer Line, hand-tighten until flare bottoms, then use a back-up wrench to tighten securely.

IMPORTANT: Replacing the liquid line filter drier is recommended if system has been commissioned. This is not necessary if this kit is being installed on a new air handler.

7. To avoid damaging the TXV, remove the bulb or wrap a wet rag around the suction line between the TXV bulb and the braze joint before brazing.

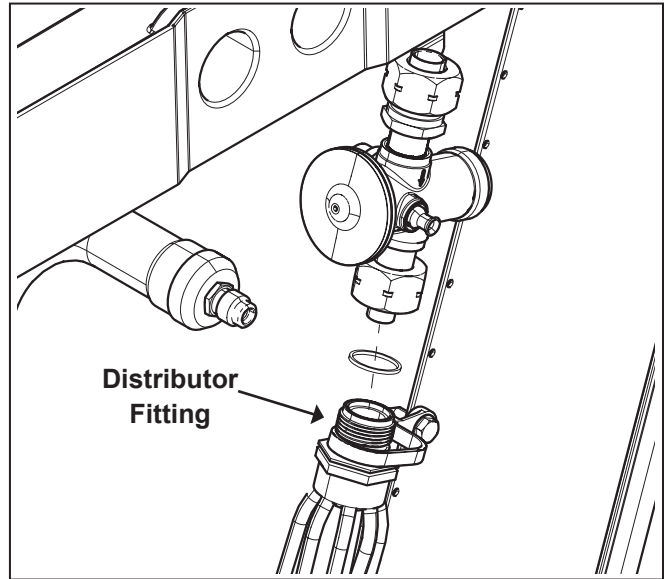

Figure 2

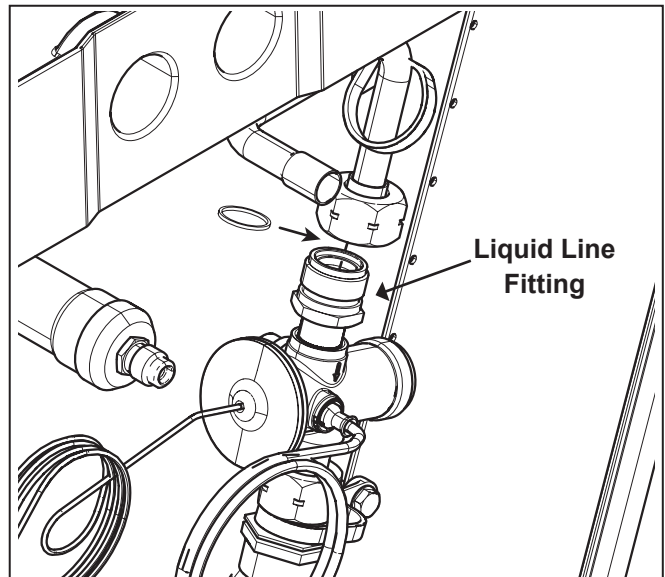

Figure 3

NOTE: GAF2 models do not require insulation around the bulb.

8. After completing the brazing operation, allow the lines to cool. Reuse the existing bulb clip or use supplied bulb strap to attach bulb to gas manifold. See Figure 4 for instructions on attaching the bulb strap. In some cases, the bulb strap may be required if the new bulb size is different from the bulb being replaced.
9. Wrap the bulb with supplied insulation and secure with supplied cable tie.

The entire length of the bulb must be in firm contact with the gas line. The remote bulb tubing must not be allowed to touch a surface colder than the remote bulb location. The remote bulb tubing must be isolated from rubbing all other components.

CAUTION

Do not allow copper and aluminum materials to touch. Maintain a minimum of .25" between copper and aluminum material to avoid galvanic corrosion which may lead to coil leaks.

Make contact tight.

- Clean the suction line thoroughly before clamping the bulb in place.
- Bulb has to be mounted in tight contact with pipe. (TIP: Shine a flashlight between bulb and suction line, realign the bulb if light is visible.)
- Align the bulb with copper gas line and position at 10 or 2 o'clock.
- Pull the bulb strap tight around the copper gas line and bulb before tightening the screw.
- After tightening, it should not be possible to move the bulb by hand.

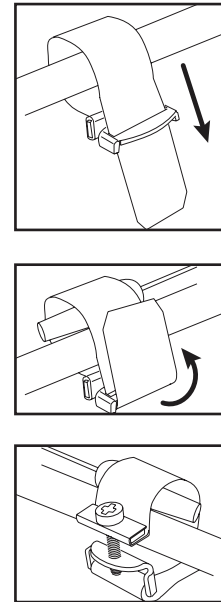

Figure 4

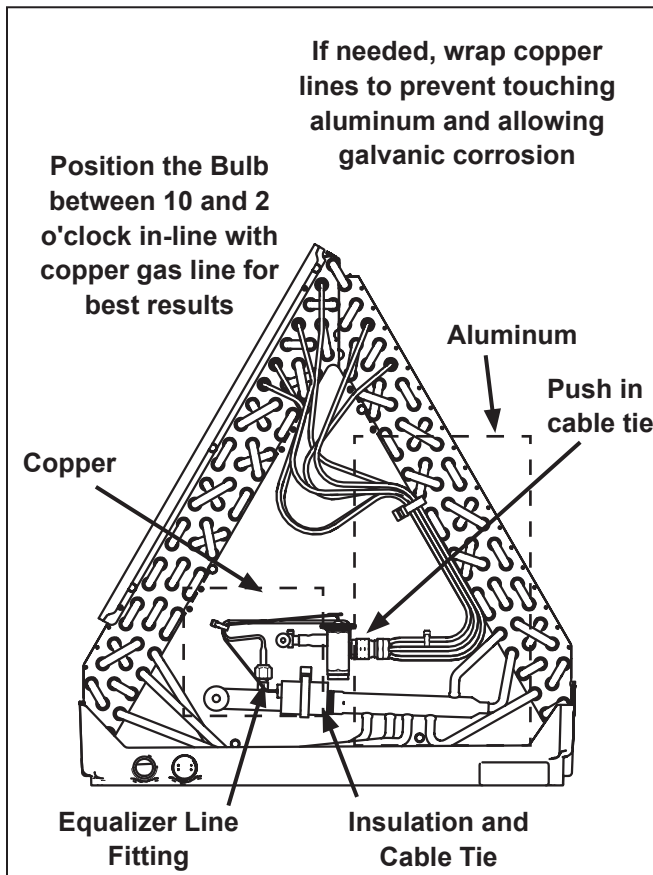

Figure 5

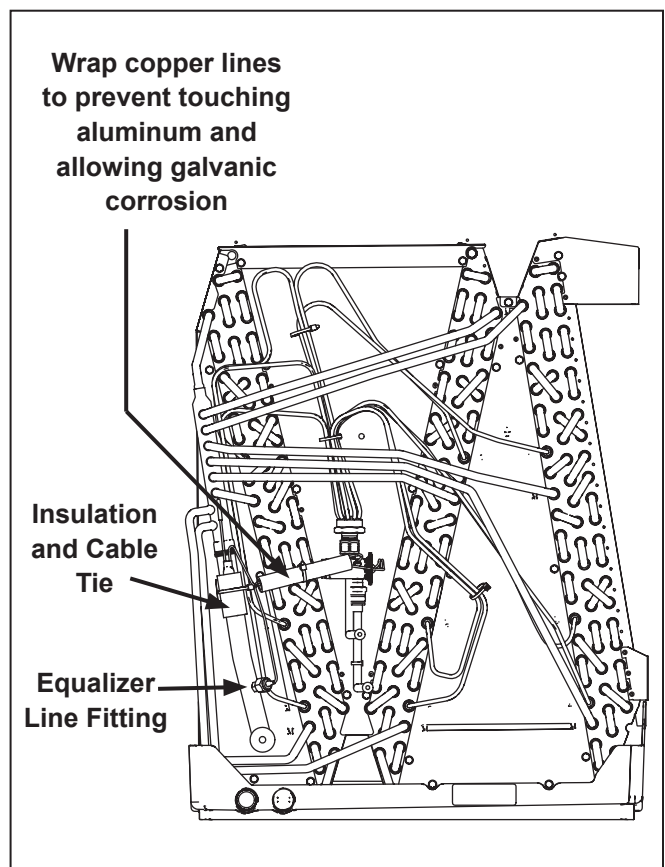

Figure 6

10. Pressurize with dry nitrogen and leak test all joints to ensure no leaks exist. Evacuate system to a minimum of 500 microns.
11. Verify that all distributor tubes are positioned over the drain pan to assure that any condensate is collected.
12. Open valves to outdoor unit if pumped-down or charge to a minimum of 50 psig static pressure. Start system and charge to appropriate level per the charging method recommended in the Outdoor Unit Installer's Guide.
13. Using a permanent marker, check the Alternative Refrigerant Type box on the Air Handler, or circle the Refrigerant Type on the Coil Name Plate after the TXV kit installation is successfully completed.

IMPORTANT: Install the caution label (Figure 7) on front panel of the unit.



Figure 7

Air Conditioning and Heat Pump Systems

TABLE 1

TXV	Description	Use with
BAYATXV1836C	R-22 TXV conversion kit	GAF2A0A18-36 GAM2A0A18-36 GAM5B0A18-24 TEM3A0B18-36 TEM4A0B18-30
BAYATXV4248C	R-22 TXV conversion kit	GAT2A0B42-48 GAM2A0B42, GAM2A0C48 GAM5B0B30-36, GAM5B0C42 TEM3A0C42-48 TEM4A0C36-48
BAYATXV6060C	R-22 TXV conversion kit	GAT2A0C60 GAM2A0C60 GAM5B0C48-60
BAYATXV6161C	R-22 TXV conversion kit	TEM3A0C60 TEM4A0C60 TEM6A0C48-60

About Trane and American Standard Heating and Air Conditioning
 Trane and American Standard create comfortable, energy efficient indoor environments for residential applications. For more information, please visit www.trane.com or www.americanstandardair.com

The manufacturer has a policy of continuous data improvement and it reserves the right to change design and specifications without notice. We are committed to using environmentally conscious print practices.