

# INSTALLER'S GUIDE

18-GH36D1-1A-EN

TAYBASE185

TAYBASE215 (TAYBASE101)

TAYBASE235 (TAYBASE100)

TAYBASE260 (TAYBASE102)

ALL phases of this installation must comply with NATIONAL, STATE AND LOCAL CODES

TAYBASE185

TAYBASE215 (TAYBASE101)

TAYBASE235 (TAYBASE100)

TAYBASE260 (TAYBASE102)

## Air Handler Downflow Sub-Bases

Used With:  
Air handlers that require downflow sub-base

**Important -- This is Customer property and is to remain with this unit. Please return to service information pack upon completion of work.**

### GENERAL

The sub-base is designed to provide isolation between combustible flooring and air handlers in down-flow installations that require a one inch (1.0") minimum clearance between the outlet duct and combustible material (as shown in figure 3). The air handler installation manual provides the length of outlet duct in which the clearance to combustible material must be maintained. Compliance with adopted codes by the authority having jurisdiction (AHJ) is required. In the absence of adopted codes, and as a minimum standard, follow NFPA 90A Standard for the installation of Air Conditioning and Ventilating Systems and / or NFPA 90B Standard for the installation of Warm Air Heating and Air Conditioning Systems.

### INSPECTION

Check carefully for any shipping damage. This must be reported to and claims made against the transportations company immediately.

### INSTALLATION LIMITATIONS & RECOMMENDATIONS

Refer to the Air Handler basic instructions for information relating to the unit location and clearances to adjacent structure.

**Note: ALL phases of this installation must comply with NATIONAL, STATE AND LOCAL CODES.**

See the table "A" for appropriate sub-base catalog number.

SUBBASE MODEL NO.	USED WITH MODELS	DUCT SIZE
TAYBASE185	All 18.5" wide air handlers	See supply outlet dimensions on Outline Drawing
TAYBASE215 (TAYBASE101)	All 21.5" wide air handlers	See supply outlet dimensions on Outline Drawing
TAYBASE235 (TAYBASE100)	All 23.5" wide air handlers	See supply outlet dimensions on Outline Drawing
TAYBASE260 (TAYBASE102)	All 26.0" wide air handlers	See supply outlet dimensions on Outline Drawing

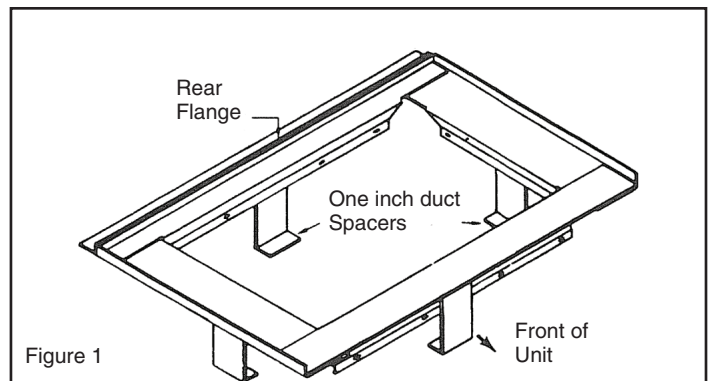

Figure 1

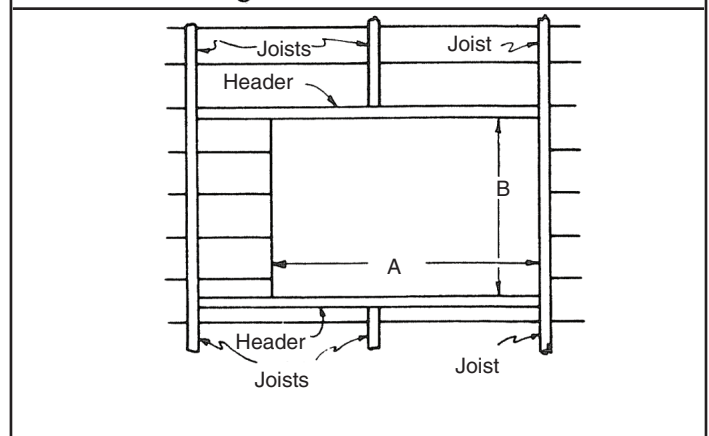
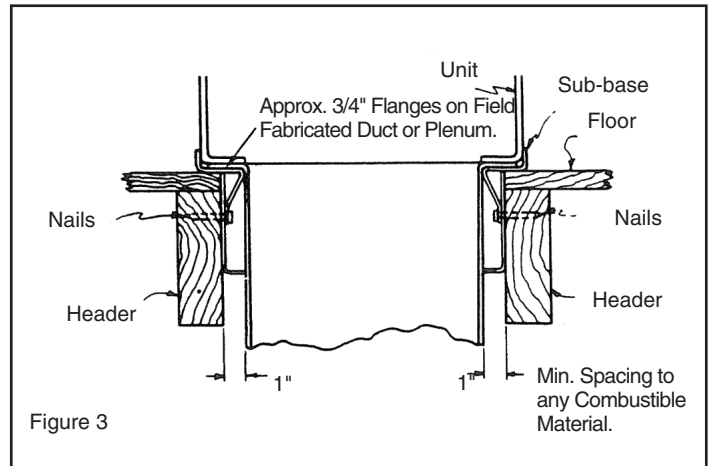

Figure 2

MODEL NO.	A	B
TAYBASE185	18-3/4	14-13/16
TAYBASE215 (TAYBASE101)	21-3/4	14-13/16
TAYBASE235 (TAYBASE100)	23-3/4	14-13/16
TAYBASE260 (TAYBASE102)	26-3/4	14-13/16

## INSTALLATION OF THE SUB-BASE

1. With the sub-base unpacked, prepare the opening.
2. The floor opening is shown in Figure 2. If the joists are cut, headers should be provided on either side of the opening to support the base unit. Check local building codes for requirements on floor loading and support.
3. Set the sub-base on the floor over the opening and nail it to the edge of the flooring in the holes provided. See Figure 3.
4. See the air handler Outline Drawing for the supply duct dimensions. Provide minimum 3/4" wide flanges on all four sides of the duct. See Figure 3.
5. Assemble the ductwork as shown in Figure 3.
6. Set the unit into place atop the base. The side and rear flanges on the base will locate the unit. Be sure the air handler is set to contact all air locating flanges. The unit cabinet will overhang the base in front.



## About Trane and American Standard Heating and Air Conditioning

Trane and American Standard create comfortable, energy efficient indoor environments for residential applications. For more information, please visit [www.trane.com](http://www.trane.com) or [www.americanstandardair.com](http://www.americanstandardair.com)

The manufacturer has a policy of continuous data improvement and it reserves the right to change design and specifications without notice. We are committed to using environmentally conscious print practices.