

Convertible Variable Speed – Air Handlers 2 1/2 - 5 Ton with Integrated Whole House Air Cleaner

2/4TEE3D31A1000A, 2/4TEE3D37A1000A, 2/4TEE3D40A1000A,
2/4TEE3D49A1000A, 2/4TEE3D65A1000A

⚠ WARNING: HAZARDOUS VOLTAGE - DISCONNECT POWER BEFORE SERVICING

ALL phases of this installation must comply with NATIONAL, STATE AND LOCAL CODES

IMPORTANT — This Document is **customer property** and is to remain with this unit. Please return to service information pack upon completion of work.

A. GENERAL INFORMATION

⚠ WARNING

THIS INFORMATION IS FOR USE BY INDIVIDUALS HAVING ADEQUATE BACKGROUNDS OF ELECTRICAL AND MECHANICAL EXPERIENCE. ANY ATTEMPT TO REPAIR A CENTRAL AIR CONDITIONING PRODUCT MAY RESULT IN PERSONAL INJURY AND/OR PROPERTY DAMAGE. THE MANUFACTURER OR SELLER CANNOT BE RESPONSIBLE FOR THE INTERPRETATION OF THIS INFORMATION, NOR CAN IT ASSUME ANY LIABILITY IN CONNECTION WITH ITS USE.

⚠ CAUTION

To prevent shortening its service life, the air handler should not be used during the finishing phases of construction. The low return air temperatures can lead to the formation of condensate. Condensate in the presence of chlorides and fluorides from paint, varnish, stains, adhesives, cleaning compounds, and cement creates a corrosive condition which may cause rapid deterioration of the cabinet and internal components.

This unit is equipped with an integrated high efficiency Whole House Air Cleaner. Careful consideration must be taken in the installation process to avoid personal injury or equipment damage. These instructions do not cover all variations in systems or provide for every possible contingency. Should further information be desired or particular problems arise which are not covered sufficiently by this manual, contact your local distributor or the manufacturer as listed on the air handler nameplate.

These Air Handlers are shipped from the factory in the upflow or horizontal right configuration and are fully convertible to downflow or horizontal left. Refer to Section C beginning on page 4 for additional information.

INSPECTION

Check carefully for any shipping damage. This must be reported to and claims made against the transportation company immediately. Check to be sure all major components are in the unit. Any missing parts should be reported to your supplier at once, and replaced with authorized parts only.

CONTENTS

| | |
|--|-----------|
| General Information | 1 |
| Installation Limitations & Recommendations | 1 |
| Two Piece Cabinet Disassembly | 4 |
| Unit Installation | 4 |
| Vertical Upflow | 4 |
| Vertical Downflow | 5 |
| Horizontal Left | 9 |
| Horizontal Right | 10 |
| Duct Connection | 10 |
| Refrigerant Piping | 13 |
| Brazing to Evaporator Section | 13 |
| Condensate Drain Piping | 13 |
| Electrical - Wiring | 14 |
| Airflow Adjustment | 15 |
| Maintenance Check Out Procedure | 16 |
| Cleaning the COLLECTION CELL | 16 |
| Cleaning the FIELD CHARGER | 17 |
| Hook Up Diagrams | 18 |
| Outline Drawings | 20 |
| Checkout Procedures | 23 |

INSTALLATION LIMITATIONS & RECOMMENDATIONS

The general location of the air handler is normally selected by the architect, contractor and/or home owner for the most effective application and satisfaction.

NOTE: *Condensation may occur on the surface of the air handler when installed in an unconditioned location. When units are installed in unconditioned spaces, verify that all electrical and refrigerant line penetrations on the air handler are sealed completely.*

Installer's Guide

These air handlers are suitable for installation in a closet, alcove or utility room with free, non-ducted, air return, using the area space as a return air plenum. With ducted supply air, if the minimum clearances to combustible materials and service access are observed, the above installations are suitable.

This area may also be used for other purposes, including an electric hot water heater- **but in no case shall a fossil fuel device be installed and/or operated in the same closet, alcove or utility room.**

In addition, these air handlers are suitable for installation in an attic, garage or crawl space with ducted supply and return air.

This equipment has been evaluated in accordance with the U.S. Department of Housing and Urban Development code. Air handler is Suitable for mobile home/manufactured housing use. Unit is also approved for modular homes.

For proper installation the following items must be considered:

1. If adequate power is available and correct according to nameplate specifications.
2. **Prior to unit installation, a heavy gauge steel plate is attached to the bottom of the unit for protection during shipping and handling. Leave this plate in place until the unit is ready to be connected to ductwork.**
3. Insulate all ducts, particularly if unit is located outside of the conditioned space.
4. Pursuant to Florida Building Code 13-610.2.A.2.1, this unit meets the criteria for a factory sealed air handler.
5. To ensure maximum efficiency and system performance, the existing supply and return duct system static pressures must not exceed the total available static pressure of the air handler. Reference ACCA Manual D, Manual S and Manual RS along with the air handler Product Data and Service Facts for additional information.

6. It is recommended that the outline drawing be studied and dimensions properly noted and checked against selected installation site. By noting in advance which knockouts are to be used, proper clearance allowances can be made for installation and future service.
7. Allow a **minimum of 21 inches clearance** in front of the air handler to permit removal of COLLECTION CELL and FIELD CHARGER.
8. Do not install air handler where air cleaner can be exposed to UV light.
9. When the air handler with supplementary heater is to be installed in the downflow position on combustible flooring an accessory sub-base (TAYBASE101 for 2/4TEE3D31, TAYBASE100 for 2/4TEE3D37, TAYBASE102 for 2/4TEE3D40-65) must be used. See Figure 1.
10. If supplementary heat is to be added, power supply must be sufficient to carry the load. In addition, minimum airflow settings, unit and duct clearances to combustible material must be maintained as stated on the air handler rating nameplate.

⚠ CAUTION

For air handlers not equipped with a factory installed electric heater, a field installed heater is available from Trane. Only heaters built by Trane are approved for use in the air handler. These heaters have been designed and tested in accordance with UL standards to provide safe and reliable operation. A list of approved heaters is provided on the air handler rating nameplate. Heaters that are not factory approved could cause damage and are not covered under equipment warranty.

NOTE: If air handler is used WITHOUT a supplementary electric heater, a sheetmetal plate is required to cover the open hole in the airflow system. See Figure 3.

Figure 1 AIR HANDLER SUB-BASE

| FLOOR OPENING - SIZE | | |
|----------------------|--------|----------|
| MODEL NO. | A | B |
| TAYBASE100 | 23-3/4 | 14-13/16 |
| TAYBASE101 | 21-3/4 | 14-13/16 |
| TAYBASE102 | 26-3/4 | 14-13/16 |

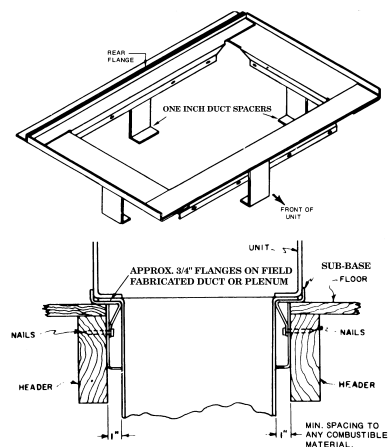
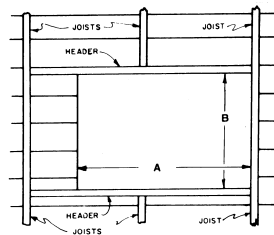
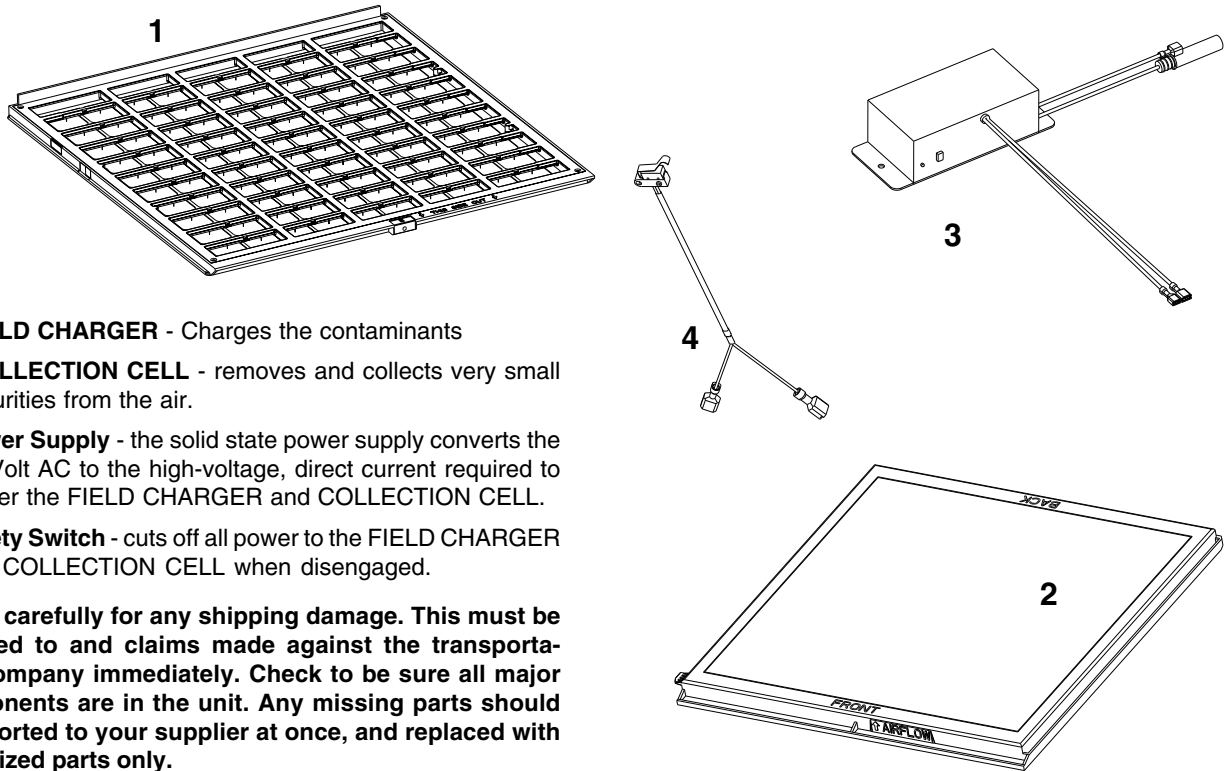

Figure 2 Components of the Integrated Whole House Air Cleaner



- 1) **FIELD CHARGER** - Charges the contaminants
- 2) **COLLECTION CELL** - removes and collects very small impurities from the air.
- 3) **Power Supply** - the solid state power supply converts the 24 Volt AC to the high-voltage, direct current required to power the FIELD CHARGER and COLLECTION CELL.
- 4) **Safety Switch** - cuts off all power to the FIELD CHARGER and COLLECTION CELL when disengaged.

Check carefully for any shipping damage. This must be reported to and claims made against the transportation company immediately. Check to be sure all major components are in the unit. Any missing parts should be reported to your supplier at once, and replaced with authorized parts only.

IF AIRHANDLER IS USED **WITHOUT** A FACTORY FURNISHED SUPPLEMENTARY HEATER, A PLATE IS REQUIRED TO COVER THE OPEN HOLE IN THE AIR FLOW SYSTEM

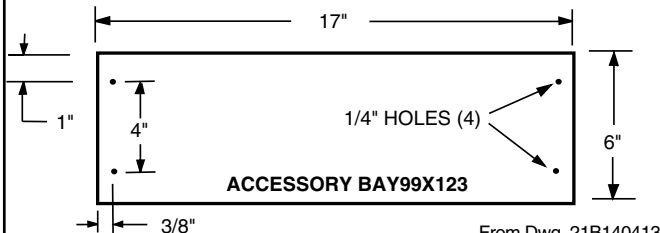

Figure 3

From Dwg. 21B140413

11. If the unit is installed without a return air duct, applicable local codes may limit this air handler to installation only in a single story residence & within conditioned space.
12. If the outdoor unit is to be installed later, or by others, then installation of the air handler must be made to allow access for refrigerant lines, or attach refrigerant lines to air handler when installing.
13. Make sure there are provisions for installing condensate drain lines.
14. If side, front or rear return is required, air handler must be elevated or placed on a plenum (TAYPLNM100 or 101). Connecting return duct directly to the side, front or rear of the cabinet is not approved.

15. Route refrigerant & condensate drain lines away from air handler so they do not interfere with access panels and COLLECTION CELL removal.
16. When external accessories are used, the additional height and width requirements must be considered in the overall space needed.
17. These units are not approved for outdoor installation.
18. These units are approved for draw-through application only.
19. **DO NOT** use silicon based sealant. This causes a coating on the FIELD CHARGER pins that will decrease the efficiency of the air cleaner.

NOTE: No atomizing style humidifier is allowed in the return plenum with the use of this unit.

20. **Flow-through Bypass Humidifiers**

Excessive bypass air may cause water blow-off, which will adversely affect system operation and air cleaner performance. To verify bypass airflow, follow the Bypass Humidifier Pre-Installation Check-out and Set-Up Procedures available through your local distributor. Ask for publication number 18-CH37D1-1.

Installer's Guide

Steam and Flow-through Fan Power Duct-mounted Humidifiers

Follow the humidifier installation instructions. These should only be installed on the supply air side of the system.

Other Duct Mounted Humidifiers are Not recommended for installation with the air cleaner.

- Unit installation must include either a return air duct or grill that prevents accidental access to pins. For upflow open air intake applications that do not have a grill or return air duct, installation will require the use of either **BAYPLNM120**, **TASB215**, **TASB235**, or **TASB260** depending on cabinet size.

TASB accessories can be purchased from:

Miami Tech Inc.
3611 NW 74 Street
Miami, Florida 33147
Phone: 800-339-2290
Fax: 305-693-6152
www.miamitech.com

TASB215 for use with 21.5" cabinets 2/4TEE3D31

TASB235 for use with 23.5" cabinets 2/4TEE3D37

TASB260 for use with 26.0" cabinets 2/4TEE3D40,49, and 65

- A **PRE-FILTER** is not required to be installed with the air handler containing a Whole House Air Cleaner. If the use of a **PRE-FILTER** is desired, it must be installed at least 6" away from the Whole House Air Cleaner.

B. TWO PIECE CABINET DISASSEMBLY (OPTIONAL)

NOTE: For easier installation into tight areas, the 4 and 5 ton air handlers can be disassembled and reassembled after moved to an attic or other space.

Steps for disassembly and reassembly (See Figures 4 and 5)

1. Disconnect wiring.
2. Remove center bracket.
3. Remove blower assembly.
4. Remove coil.
5. Cut foil tape - minimum 3" foil tape.
6. Remove top 8 screws. See Figure 3.
7. Lift upper section.
8. Set air handler in place.
9. Attach screws - insure gaskets are aligned along flange.
10. Use foil tape to seal - use minimum 3" foil tape.
11. Insert coil.
12. Reinstall blower assembly.
13. Reinstall center bracket.
14. Reconnect wiring.

NOTE: In Downflow, remove coil before blower by reversing steps 4 and 5.

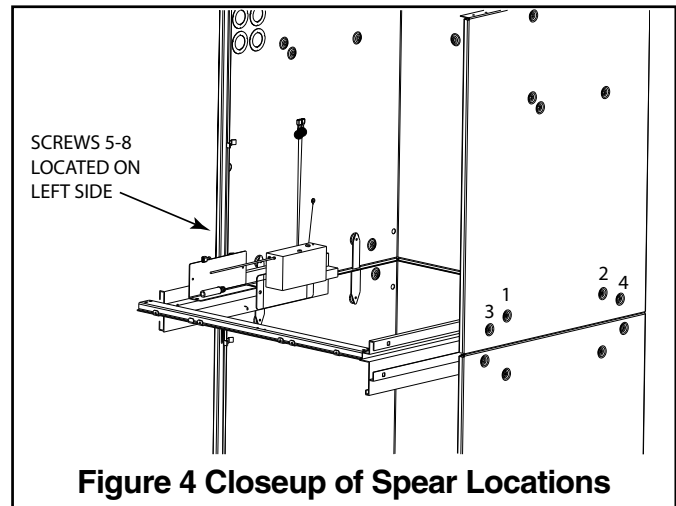

Figure 4 Closeup of Spear Locations

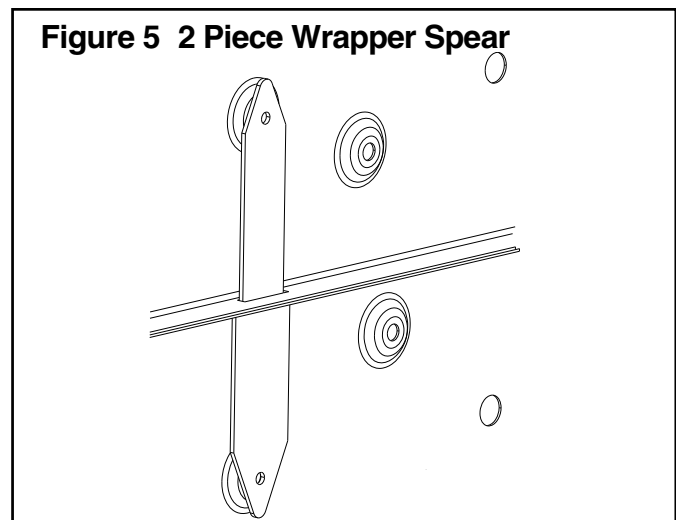

Figure 5 2 Piece Wrapper Spear

C. UNIT INSTALLATION UPFLOW

⚠ CAUTION

When unit is installed in non-ducted applications, BAYPLNM120 must be used.

- Before installing unit, remove thumbscrews to the filter panel. Carefully remove the **COLLECTION CELL** by grasping the leading edge of the frame. See Figure 6. Set aside in a safe place until the unit is set in place and ready to start up.
- Use a 5/16" nutdriver to remove the screws holding the **FIELD CHARGER** retainer and take out both. Slightly lift the **FIELD CHARGER** and carefully remove. Set aside in a safe place until the unit is set in place and ready to start up. See Figures 7 and 8.
- Position unit to remove the bottom protector plate by laying the unit on its back. Use a flat blade screwdriver between the protector plate and the unit to pry apart. See Figure 9. Gently pull the plate towards the front of the unit to remove.

- d. **For maximum efficiency**, the horizontal drip tray should be removed. See Figures 10, 11 and 12. Tray removal requires that the coil be removed by sliding the coil out on the coil channel supports. For the TEE3D40-65 units, there is a coil support tab at the top of the coil connected to the case that must be removed first. Remove 1 inch insulation strip covering the lip of the drip tray. The tray is detached by removing the two screws at the drain pan. Remove the two screws holding the two brackets at the top of the coil. Remove drip tray by gently breaking the seal between the drip tray and drain pan.
- e. Remove the factory installed baffle assembly from the apex of the coil by using a 5/16" nutdriver to remove the screws. Replace this baffle with the factory supplied narrow coil baffle using the screws removed previously. See Figure 15. Reinstall coil assembly.

CAUTION

When installing the narrow coil baffle, make sure to align the baffle up with the holes so NOT to puncture the coil tubing.

- f. Position unit on Pedestal or other suitable foundation. If Pedestal is not used, a frame strong enough to support the total weight must be provided. Provide a minimum height of 14 inches for proper unrestricted airflow. In open return applications, installation requires a **BAYPLNM** or **TASB** stand.
- g. If a return air duct is connected to the air handler, it must be the same dimensions as shown in the outline drawing on page 20.
- h. **On units with sheetmetal returns: Return plenum must be flanged. Sheetmetal screws must be 1/2" in length or shorter. Self-tapping screws are supplied with unit in accessory pack.** See Figure 17.
- i. **No sheetmetal screws may be used to attach return duct work on the side of the unit.**
- j. Pedestal and unit should be isolated from the foundation using a suitable isolating material.
- k. **Openings where field wiring enters the cabinet must be completely sealed.** Location of power entry is shown on the Outline Drawing. Use 2.5" clear stickers provided to seal all unused electrical knockouts. See Figure 16.
- l. After ductwork connections are made, seal airtight and per Local codes.
- m. Install **FIELD CHARGER** as shown in Figure 18 (Upflow). Ionizing pins must face downward (into the return air stream) and electrical contacts must be on the left side of the unit.
- n. Reinstall **FIELD CHARGER** retainer bracket.

- o. Install **COLLECTION CELL** as shown in Figure 18 (Upflow) so that electrical contacts and actuator tab are on the left side of the unit.
- p. Install filter panel with thumbscrews.

DOWNFLOW

- a. Before installing unit, remove thumbscrews to the filter panel. Carefully remove the **COLLECTION CELL** by grasping the leading edge of the frame. See Figure 6. Set aside in a safe place until the unit is set in place and ready to start up.
- b. Use a 5/16" nutdriver to remove the screw in the **FIELD CHARGER** retainer and take out both. Slightly lift the **FIELD CHARGER** and carefully remove. Set aside in a safe place until the unit is set in place and ready to start up. See Figures 7 and 8.
- c. Position unit to remove the bottom protector plate by laying the unit on its back. Use a flat blade screwdriver between the protector plate and the unit to pry apart. See Figure 9. Gently pull the plate towards the front of the unit to remove.
- d. **For maximum efficiency**, the horizontal drip tray should be removed. See Figures 10, 11 and 12. Tray removal requires that the coil be removed by sliding the coil out on the coil channel supports. For the TEE3D40-65 units, there is a coil support tab at the top of the coil connected to the case that must be removed first. Remove 1 inch insulation strip covering the lip of the drip tray. The tray is detached by removing the two screws at the drain pan and the two screws holding the two brackets at the top of the coil. Remove drip tray by gently breaking the seal between the drip tray and drain pan.
- e. Remove the factory installed baffle assembly from the apex of the coil by using a 5/16" nutdriver to remove the screw. Replace this baffle with the factory supplied narrow coil baffle using the screws removed previously. See Figure 15.

CAUTION

When installing the narrow coil baffle, make sure to align the baffle up with the holes so NOT to puncture the coil tubing.

NOTE: Installation of the downflow baffle kit included with unit is required on downflow applications. See Figure 14.

- f. Remove front shield by removing screws on right side. Make sure to reinstall front shield after baffle changes. See Figure 14.
- g. Detach the coil from the drain pan by removing 4 screws as shown in Figure 14.

Installer's Guide

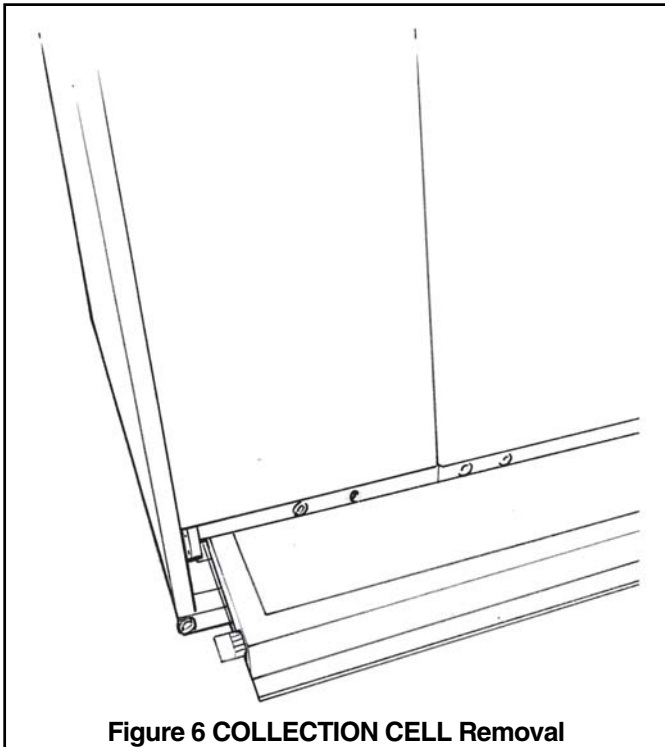

Figure 6 COLLECTION CELL Removal

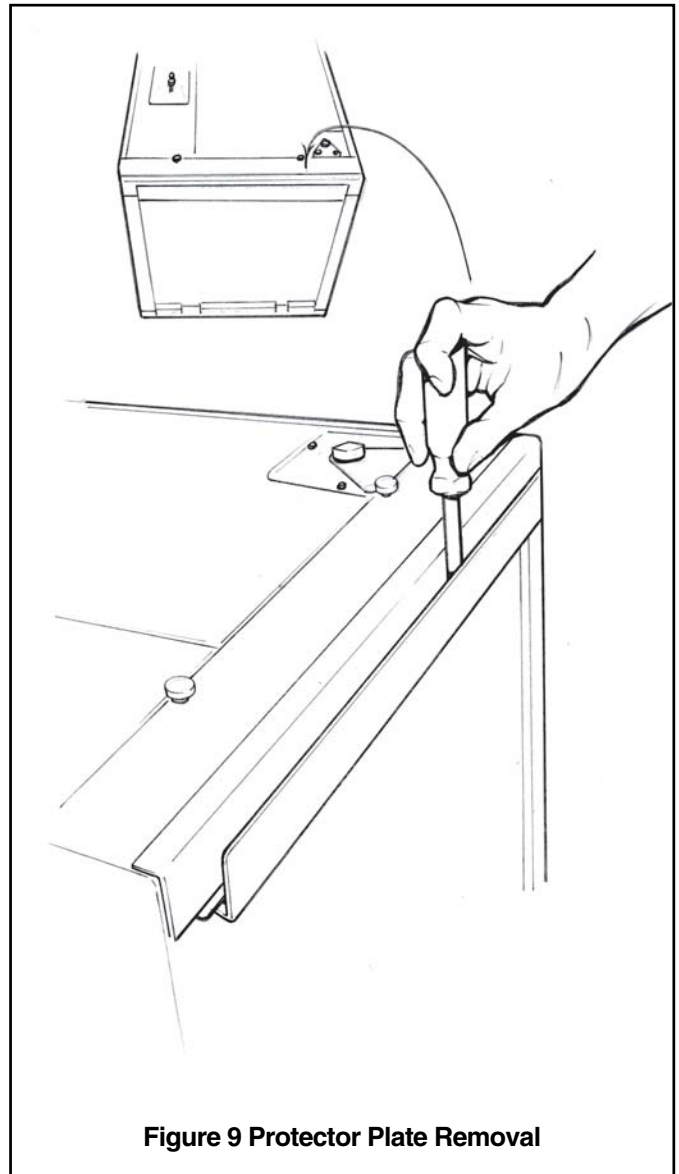

Figure 9 Protector Plate Removal

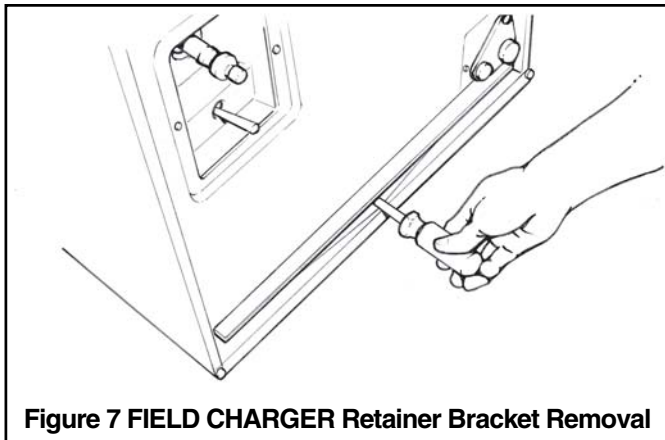

Figure 7 FIELD CHARGER Retainer Bracket Removal

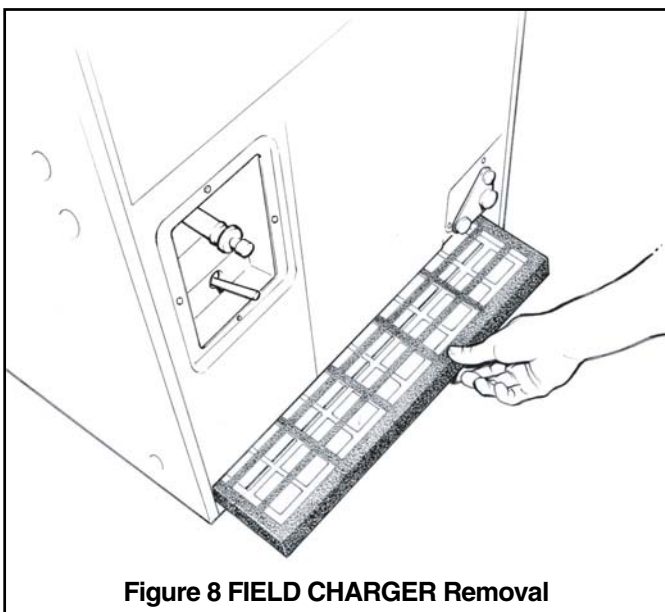

Figure 8 FIELD CHARGER Removal

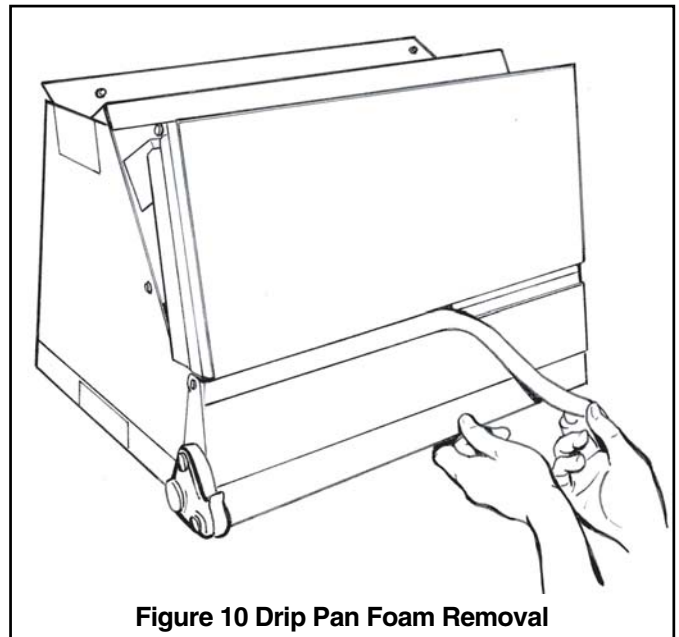

Figure 10 Drip Pan Foam Removal

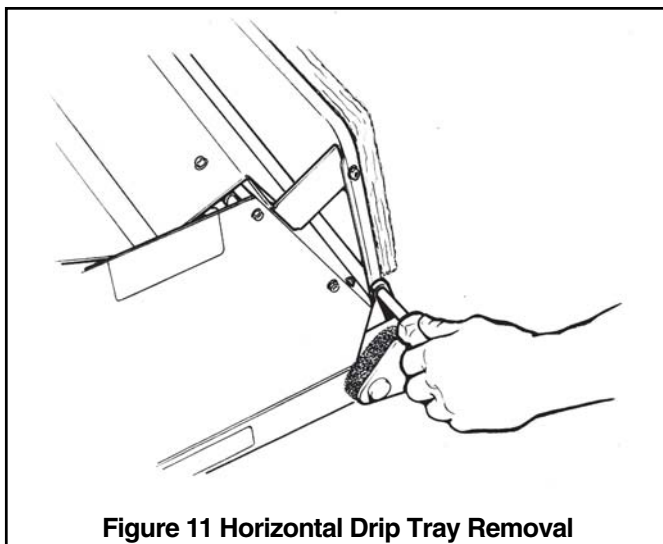

Figure 11 Horizontal Drip Tray Removal

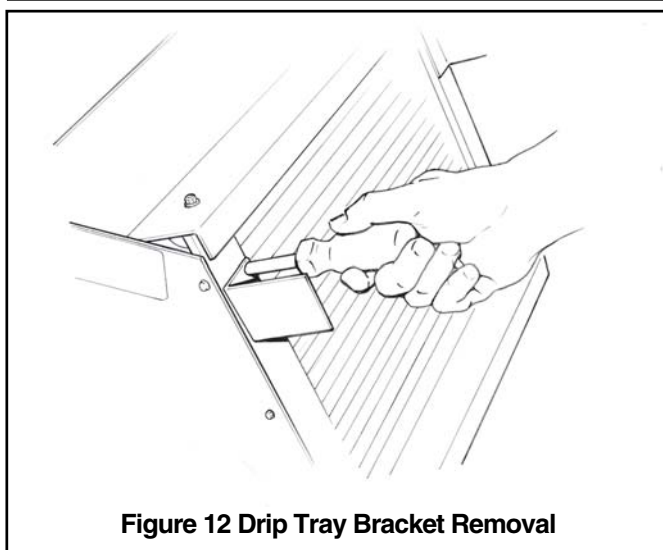

Figure 12 Drip Tray Bracket Removal

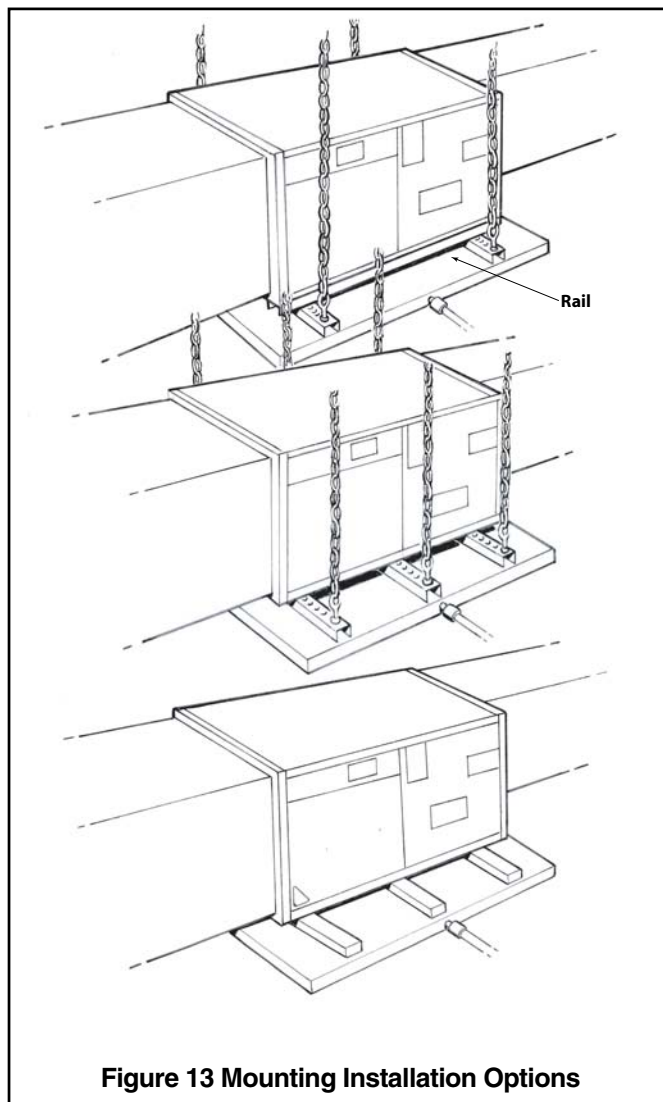

Figure 13 Mounting Installation Options

- h. Remove the front triangular baffle from the coil and install the 1/2" wide gasket provided per Figure 14. Trim the gasket length to fit the baffle. Reinstall the baffle to coil, with gasket material compressed against the coil.
- i. Install the water blow-off baffles provided on each side of the coil with the flange at the top as shown in Figure 14. The bottom of the baffle is to be as close to the bottom of the coil as possible.
- j. Install the 7/8" wide gasket in each side of the drain pan as shown in Figure 14 (sect. X-X).
- k. The 5 ton model (2/4TEE3D65) requires 2 water diverter baffles to be placed underneath the coil on the inside edge of the drain pan. See Figure 14. Fill the bend in the baffle which fits the inner edge of the drain pan with non-acetic acid RTV type adhesive/sealant before installing the

baffle. Ensure sealant is dry/set before reinstalling the coil.

- l. The unit is then placed with the blower side down and the coil is replaced on the coil channel supports with the drain connections at the bottom. The unit is now in downflow position with front access. Do not reattach coil support tab.
- m. When supplementary heaters are used, accessory subbase (TAYBASE101 for 2/4TEE3D31, TAYBASE100 for 2/4TEE3D37, and TAYBASE102 for 2/4TEE3D40-65) must be used. See Figure 1.
- n. If a return duct is connected to the air handler, it must be the same dimensions as the return opening shown in the outline drawing on page 20.
- o. **On units with sheet metal returns: Return plenum must be flanged. Sheetmetal screws must be 1/2" in length or shorter. Self-tapping screws are supplied with the unit in accessory packet. See Figure 17.**

Installer's Guide

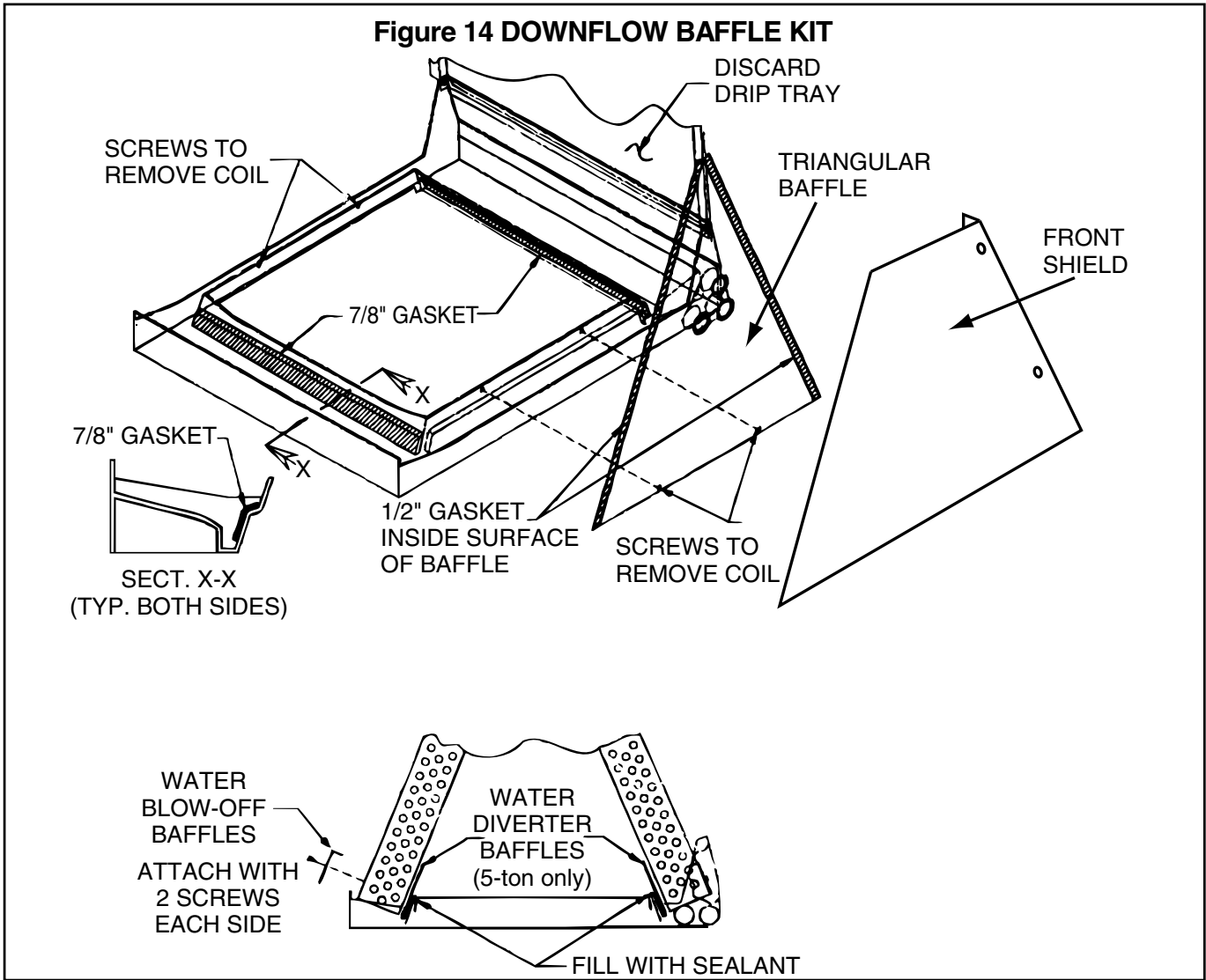

- p. **No sheetmetal screws may be used to attach return ductwork on the side of the unit.**
- q. Install **FIELD CHARGER** as shown in Figure 18 (Downflow). Ionizing pins must face upward (into the return air stream) and electrical contacts must be on the right side of the unit.
- r. Reinstall **FIELD CHARGER** retainer bracket.
- s. Install **COLLECTION CELL** as shown in Figure 18 (Downflow) so that electrical contacts and actuator tab are on the right side of the unit.
- t. Install filter panel with thumbscrews.
- u. **Openings where field wiring enters the cabinet must be completely sealed.** Location of power entry is shown on the outline drawing.

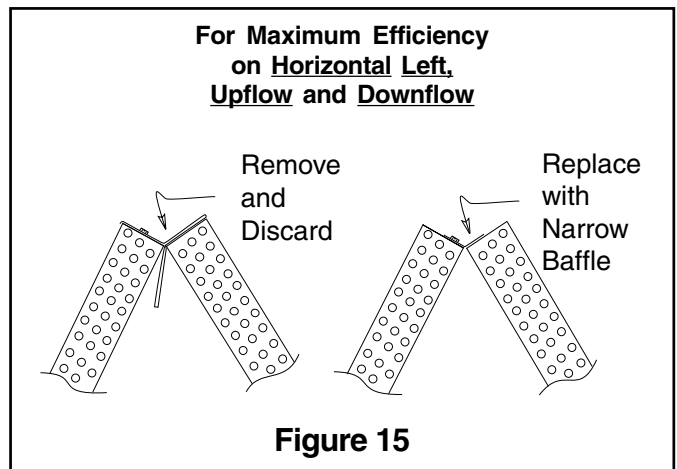

Use 2.5" clear stickers provided to seal all unused electrical knockouts. See Figure 16.

- v. After ductwork connections are made, seal airtight and per Local codes.

HORIZONTAL LEFT

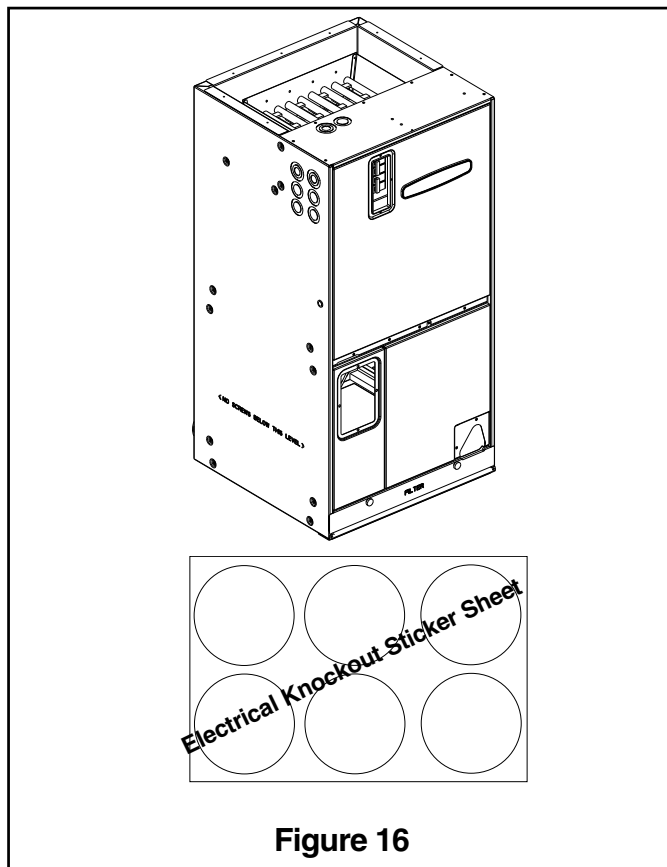

Figure 16

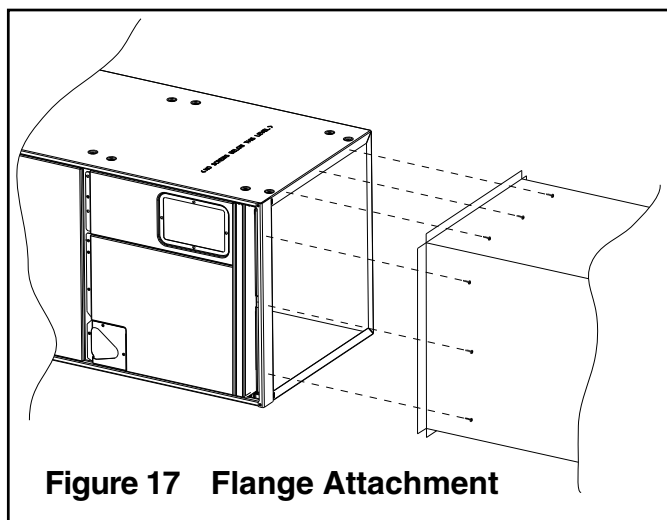

Figure 17 Flange Attachment

- a. Before installing unit, remove thumbscrews to the filter panel. Carefully remove the COLLECTION CELL by grasping the leading edge of the frame. See Figure 6. Set aside in a safe place until the unit is set in place and ready to start up.
- b. Use a 5/16" nutdriver to remove the screws in the FIELD CHARGER retainer and take out both. Slightly lift the FIELD CHARGER and carefully remove. Set aside in a safe place until the unit is set in place and ready to start up. See Figures 7 and 8.

- c. Position unit to remove the bottom protector plate by laying the unit on its back. Use a flat blade screwdriver between the protector plate and the unit to pry apart. See Figure 9. Gently pull the plate towards the front of the unit to remove.
- d. To convert the unit to horizontal left, front access, slide the coil out on the coil channel supports and rotate the complete coil 180 degrees.
- e. **For maximum efficiency**, remove the factory installed baffle assembly from the apex of the coil by using a 5/16" nutdriver to remove the hex head screws. For the TEE3D40-65 units, there is a coil support tab at the top of the coil connected to the case must be removed first. Replace this baffle with the factory supplied narrow coil baffle using the screws removed previously. See Figure 15.

⚠ CAUTION

When installing the narrow coil baffle, make sure to align the baffle up with the holes so NOT to puncture the coil tubing.

- f. The coil is then inserted back into the cabinet on the opposite side coil channel supports. The unit is now horizontal left with front access. Do not reattach coil support tab.
- g. If the unit is suspended, it must be supported from the bottom near both ends as well as the middle to prevent sagging. The service access must remain unobstructed. If the unit is supported along the length of the front and back with rails, the air handler only needs to be suspended at both ends. See Figure 13.
If the unit is not suspended it must be supported as mentioned above and isolated carefully to prevent sound transmission. Vibration isolators (purchased locally) must be placed under the unit.
- h. It is always recommended that an auxiliary drain pan be installed under a horizontal air handler (See Condensate Piping) to prevent possible damage to ceilings.
- i. Isolate the auxiliary drain pan from the unit or from the structure.
- j. Connect the auxiliary drain line to a separate drain line (no trap is needed in this line) and terminate according to National and Local codes.
- k. If a return duct is connected to the air handler, it must be the same dimensions as the return opening shown in the outline drawing on page 20.
- l. **On units with sheetmetal returns: Return plenum must be flanged. Sheetmetal screws**

Installer's Guide

must be 1/2" in length or shorter. Self-tapping screws are supplied with the unit in accessory packet. See Figure 17.

- m. **No sheetmetal screws may be used to attach return ductwork on the side of the unit.**
- n. Install FIELD CHARGER as shown in Figure 19 (Horizontal Left). Ionizing pins must point into the return air stream (right). Electrical contacts will now be on the bottom of the FIELD CHARGER.
- o. Reinstall FIELD CHARGER retainer bracket.
- p. Install COLLECTION CELL as shown in Figure 19 (Horizontal Left) so that electrical contacts and actuator tab are on the bottom of the COLLECTION CELL.
- q. Install filter panel with thumbscrews.
- r. **Openings where field wiring enters the cabinet must be completely sealed.** Location of power entry is shown on the outline drawing. Use 2.5" clear stickers provided to seal all unused electrical knockouts. See Figure 16.
- n. After ductwork connections are made, seal airtight and per Local codes.

HORIZONTAL RIGHT

- a. Before installing unit, remove thumbscrews to the filter panel. Carefully remove the COLLECTION CELL by grasping the leading edge of the frame. See Figure 6. Set aside in a safe place until the unit is set in place and ready to start up.
- b. Use a 5/16" nutdriver to remove the screws holding the FIELD CHARGER retainer and take out both. Slightly lift the FIELD CHARGER and carefully remove. Set aside in a safe place until the unit is set in place and ready to start up. See Figures 7 and 8.
- c. Position unit to remove the bottom protector plate by laying the unit on its back. Use a flat blade screwdriver between the protector plate and the unit to pry apart. See Figure 9. Gently pull the plate towards the front of the unit to remove.
- d. Unit is shipped from the factory in the upflow or horizontal right configuration. Unit conversion is not required.
- e. If the unit is suspended, it must be supported from the bottom near both ends as well as the middle to prevent sagging. The service access must remain unobstructed. If the unit is sup-

ported along the length of the front and back, the air handler only needs to be suspended at both ends. See Figure 13.

If the unit is not suspended it must be supported as mentioned above and isolated carefully to prevent sound transmission. Vibration isolators (purchased locally) must be placed under the unit.

- f. It is always recommended that an auxiliary drain pan be installed under a horizontal air handler (See Condensate Drain Piping) to prevent possible damage to ceilings.
- g. Isolate the auxiliary drain pan from the unit or from the structure.
- h. Connect the auxiliary drain line to a separate drain line (no trap is needed in this line) and terminate according to National and Local codes.
- i. If a return duct is connected to the air handler, it must be the same dimensions as the return opening shown in the outline drawing on page 20.
- j. **On units with sheetmetal returns: Return plenum must be flanged. Sheetmetal screws must be 1/2" in length or shorter. Self-tapping screws are supplied with the unit in accessory packet.** See Figure 17.
- k. **No sheetmetal screws may be used to attach return ductwork on the side of the unit.**
 - l. Install FIELD CHARGER as shown in Figure 19 (Horizontal Right). Ionizing pins must point into the return air stream (left). Electrical contacts will now be on the top of the FIELD CHARGER.
- m. Reinstall FIELD CHARGER retainer bracket.
- n. Install COLLECTION CELL as shown in Figure 19 (Horizontal Right) so that electrical contacts and actuator tab are on the top of the COLLECTION CELL.
- o. Install filter panel with thumbscrews.

Figure 18 COLLECTION CELL AND FIELD CHARGER ORIENTATIONS

UPFLOW

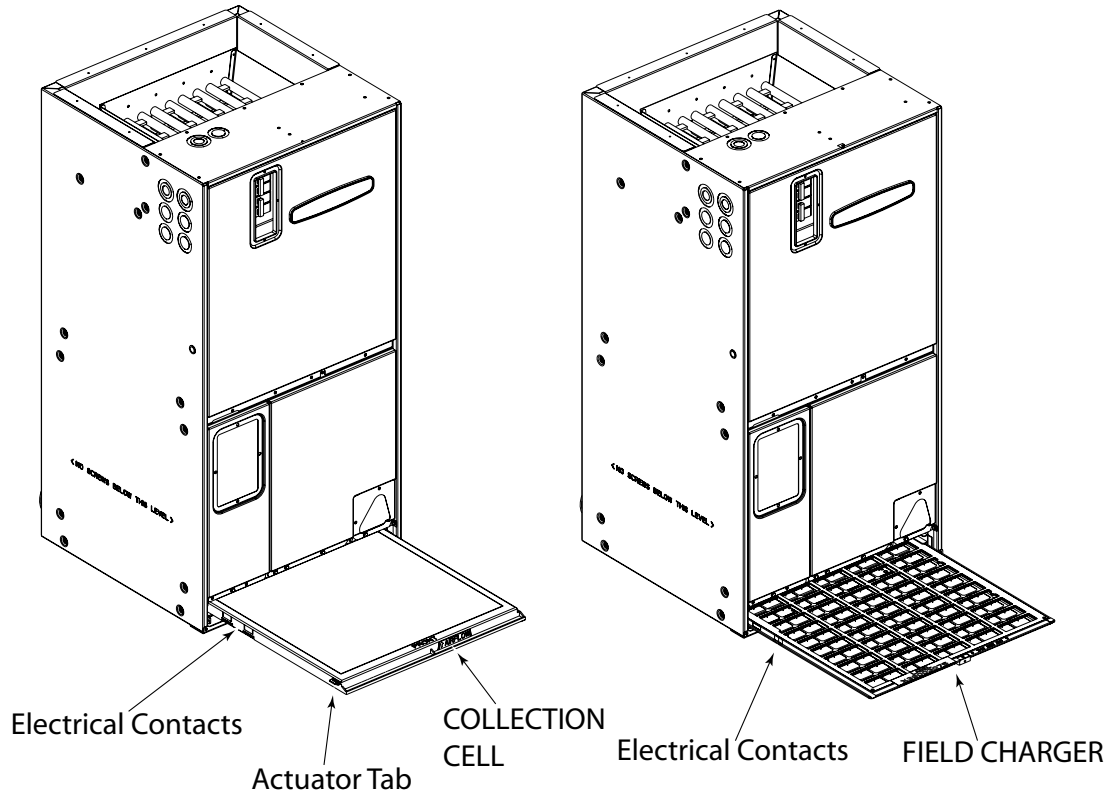

DOWNFLOW

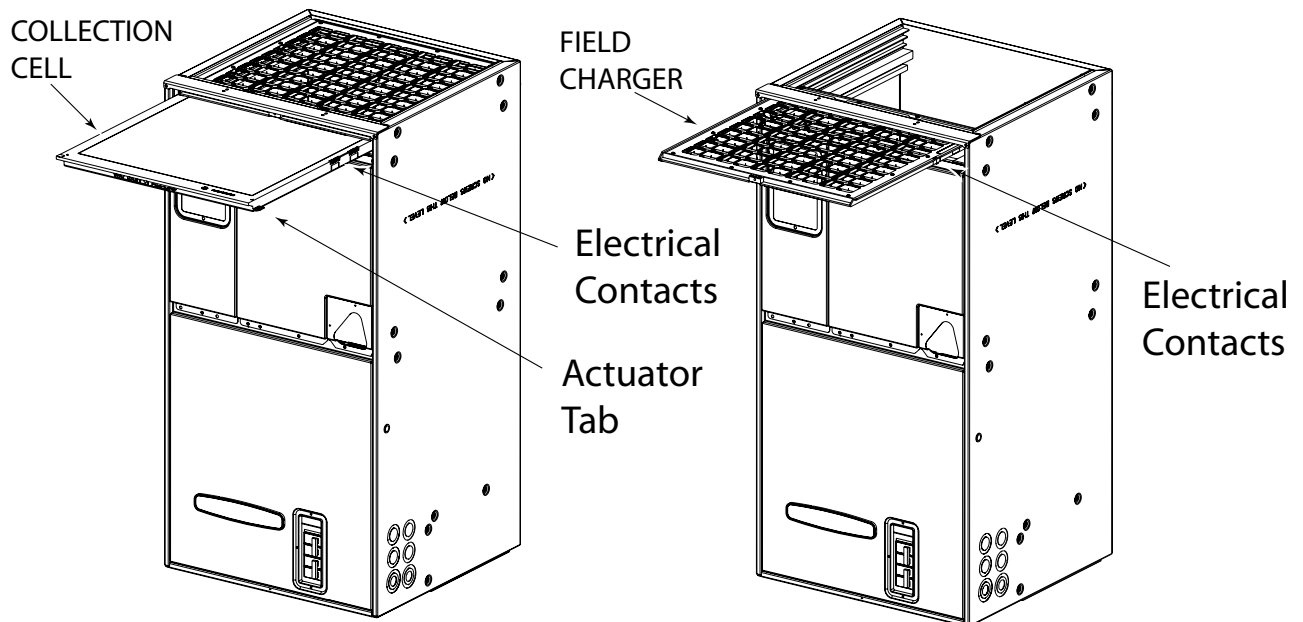
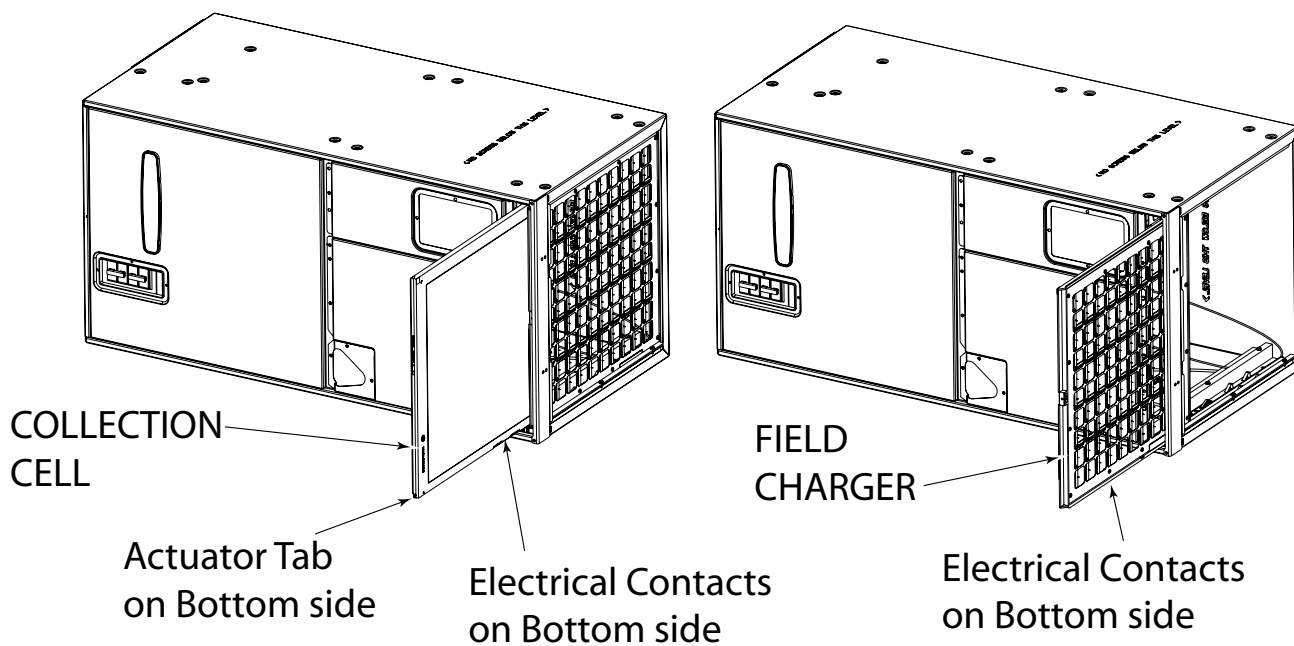
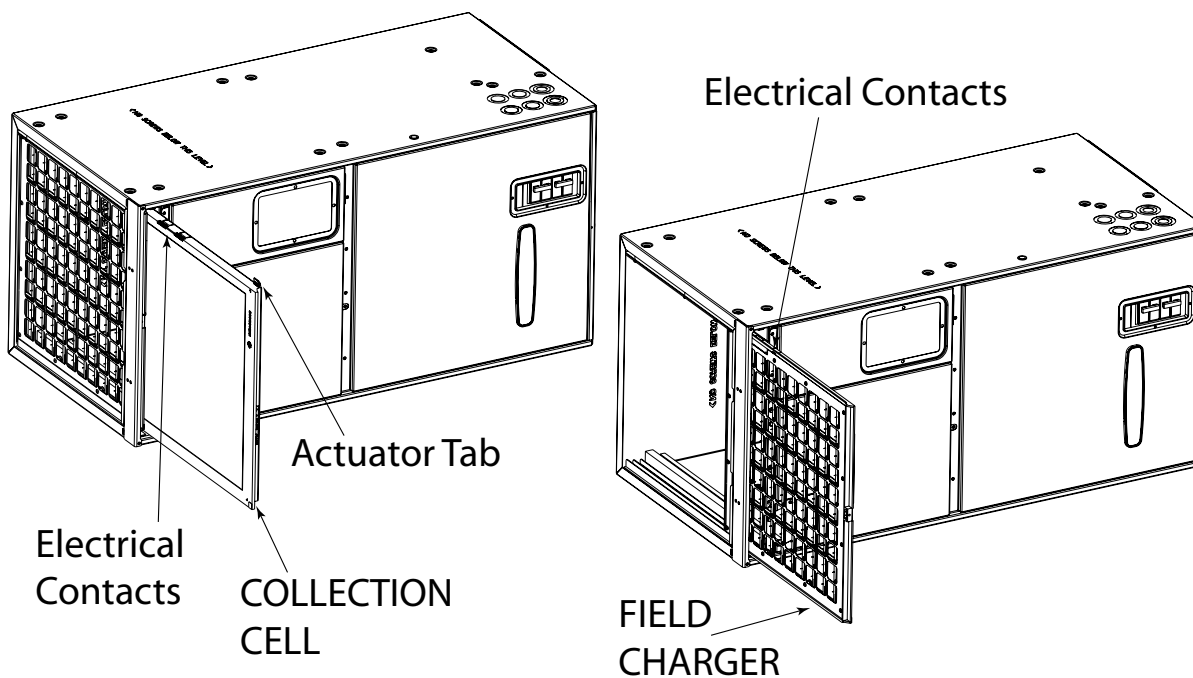

Figure 19 COLLECTION CELL AND FIELD CHARGER ORIENTATIONS

HORIZONTAL LEFT



HORIZONTAL RIGHT



p. Openings where field wiring enters the cabinet must be completely sealed. Location of power entry is shown on the outline drawing. Use 2.5" clear stickers provided to seal all unused electrical knockouts. See Figure 16.

q. After ductwork connections are made, seal airtight and per Local codes.

D. DUCT CONNECTIONS

The supply and return air ducts should be connected to the unit with flame retardant duct connectors. Convertible duct flanges are provided on the discharge opening to provide a "flush fit" for 3/4" or 1-1/2" duct board applications, see the Outline drawing on page 20 for sizes of the duct connections. After the duct is secured, seal around the supply duct to prevent air leakage.

NOTE: No sheetmetal screws may be used to attach return ductwork on the side.

NOTE: On units with sheetmetal returns: Return plenum must be flanged. Sheetmetal screws must be 1/2" in length or shorter to ensure no contact with air cleaner or components. Self-tapping screws are supplied with the unit in the accessory pack. See Figure 17.

NOTE: If the convertible duct flanges are not used, they must be removed and discarded for proper airflow.

NOTE: Any duct board return connection can be made to the sides of the unit using tape or mastic.

E. REFRIGERANT PIPING

IMPORTANT:

Refrigerant piping must be routed to maintain service access to blower compartment and provide easy removal of filter access panel and COLLECTION CELL.

1. Refrigerant connections are made outside the cabinet.

NOTE: TXV bulb MUST be protected (wrap a wet rag around the suction line between the TXV bulb and the braze joint) or removed, while brazing the tubing. Overheating of the sensing bulb will affect the functional characteristics and performance of the air handler.

Figure 20

BRAZE SHIELD

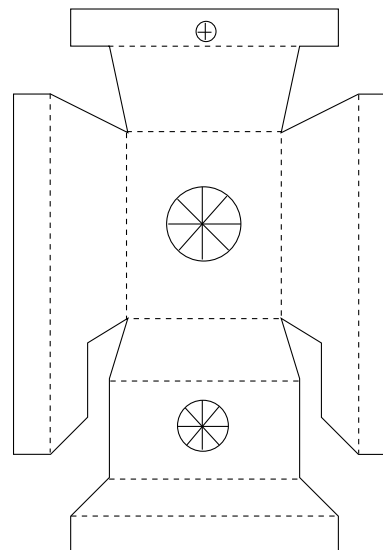

NOTE: Penetration around the Refrigerant lines must be sealed and Electrical inlets must be sealed at both the low and the high voltage.

2. Installation of refrigerant lines is covered in the installation instructions packaged with the outdoor unit. Evacuation, leak testing and brazing procedures are included in those instructions. Read those instructions before starting installation of refrigerant lines.

F. BRAZING TO EVAPORATOR SECTION

NOTE: A brazing shield is provided in the information pack accompanying this unit. This shield fits over the refrigerant fittings while brazing. Wet the shield before brazing. See Figure 20.

IMPORTANT:

Do NOT unseal refrigerant tubing until ready to cut and fit refrigerant lines.

1. Remove both sealing caps from indoor coil.
2. Field supplied tubing should be cut squared-off, ensuring the tube is still round and free of burrs at the connecting end. Clean the tubing to prevent contaminants from entering the system.
3. Run refrigerant tubing into the stub sockets of indoor unit coil. **Refrigerant line openings must be completely sealed.**
4. Braze and evacuate according to indoor and outdoor installation instructions.
5. Seal around refrigerant lines.

PAINTED AREAS OF UNIT MUST BE SHIELDED DURING BRAZING

G. CONDENSATE DRAIN PIPING

NOTE: Make certain that the unit has been installed in a level position to ensure proper draining.

Installer's Guide

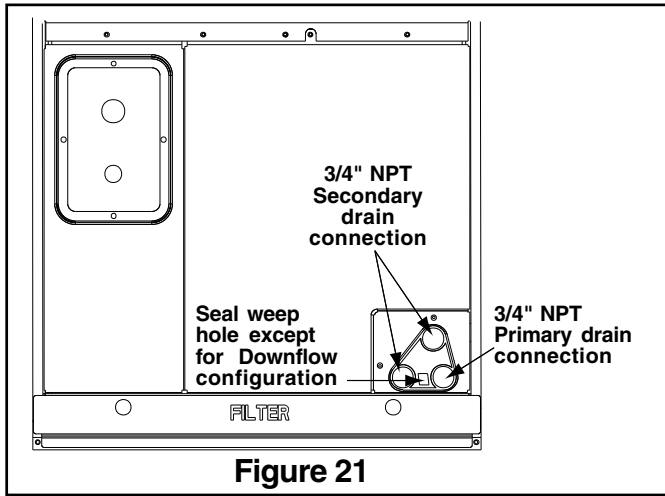

The indoor blower is downstream of the evaporator coil which creates a negative pressure at the condensate drain connections during operation. The condensate drain connections in front of the indoor coil are 3/4" NPT. The lower connection is the primary drain. See Figure 21.

Two secondary drain connections are provided for the different orientations (See Figure 21). The lower of the two should be connected as a backup to prevent condensate overflow by a blocked primary drain. The weep hole in center of drain coupling area should be sealed

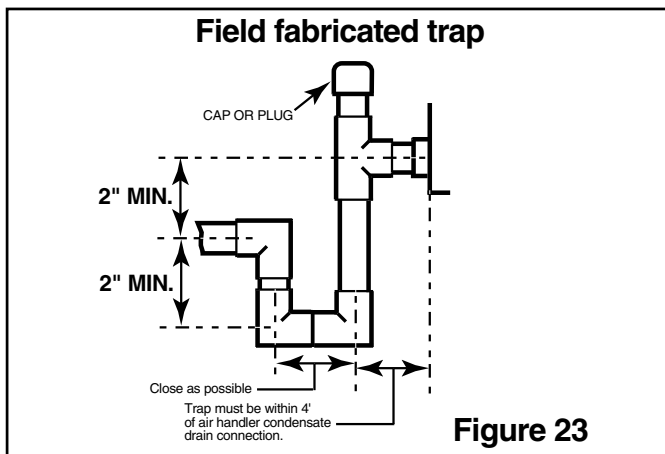
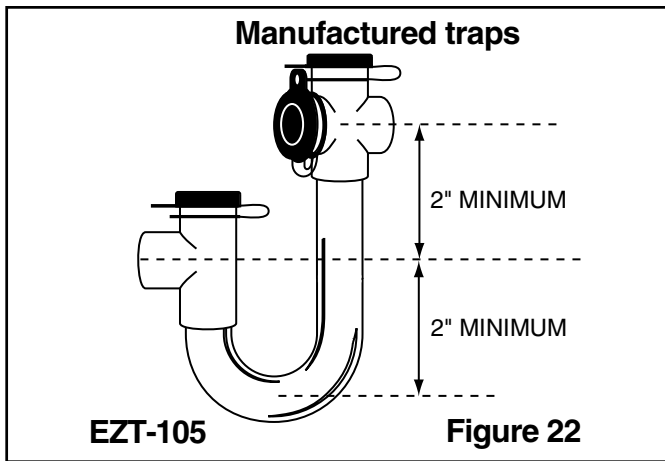

with caulk or RTV except in downflow unless secondary drain is connected.

For proper drainage of condensate, the following steps must be followed:

1. The primary drain line must be trapped with a minimum of 2" water seal as shown in Figures 22 & 23. **Do NOT use preformed 3/4" PVC running traps.** The use of Field fabricated or manufactured traps as shown in Figures 22 & 23 is acceptable. The manufactured trap shown in Figure 22 allows for a float switch option to be added. Refer to the float switch manufacturers data and instructions for details.
2. The trap must be located within 4 feet of the air handler drain outlet connection.
3. It is recommended that a clean-out tee or cross be installed in the primary drain line for future maintenance (See Figures 22 & 23).
4. Do not use reducing fittings in the condensate drain lines.
5. Slope the drain lines downward a minimum of 1/4" per foot.
6. Insulate the primary drain to prevent sweating where pipe temperature could meet or fall below dewpoint temperatures.
7. **Provide means for drainage to prevent winter freeze-up of condensate line.**
8. Do not connect the drain line to a closed drain system.
9. Use Teflon® tape on the air handler drain line connections! **Do Not** Use pipe joint compound or PVC/CPVC cement!

It is **always** recommended that an auxiliary drain pan be installed under a horizontally installed air handler. Connect the auxiliary drain line to a separate drain line (no trap is needed in this line) and terminate according to National and Local codes.

NOTE: DO NOT use a torch or flame near the plastic drain pan coupling.

NOTE: DO NOT tighten the drain pipe excessively. Support the condensate piping and traps outside the unit to prevent strain on the drain coupling.

H. ELECTRICAL — POWER WIRING

1. These Air Handlers are shipped from the factory wired for 230 volts. The units may be wired for 208 volts. Follow instructions on unit wiring diagram located on blower housing and in the Service Facts document included with the unit.
2. The selection of wire and fuse sizes should be made according to the Minimum Branch Circuit Ampacity and the Maximum Overcurrent Device listed on the unit nameplate.

⚠ WARNING

TO PREVENT INJURY OR DEATH DUE TO ELECTRICAL SHOCK OR CONTACT WITH MOVING PARTS, LOCK UNIT DISCONNECT SWITCH IN OPEN POSITION BEFORE SERVICING UNIT.

- Field wiring diagrams for electric heaters and unit accessories are shipped with the accessory.
- Wiring must conform to National and Local codes. If an electric heater is not installed, the Knockout Plate provided in the Accessory Kit **MUST** be installed on the air handler and the conduit terminated to it. The electrical connections are made using the two power leads and ground wire connections which are located near the discharge of the blower.

NOTE: If air handler is used *with* or *without* a heater, the electrical entry hole as well as any other cabinet penetrations *must be sealed air-tight*.

I. CONTROL WIRING

- Connect wiring between indoor unit, outdoor unit and Comfort Control. The use of color-coded low-voltage wires is recommended.
- A low voltage terminal board is provided for control wiring, and is located on the left side of the cross brace in the center of the unit.
- Field wiring diagrams are provided on page 18 and 19 which show the low voltage wiring hookup for a single speed cooling only system (with supplementary heaters) and a heat pump system (with supplementary heaters). Plug in type electrical connectors are provided for use with supplementary heaters.

IMPORTANT:

When supplementary heaters are installed, inspect to

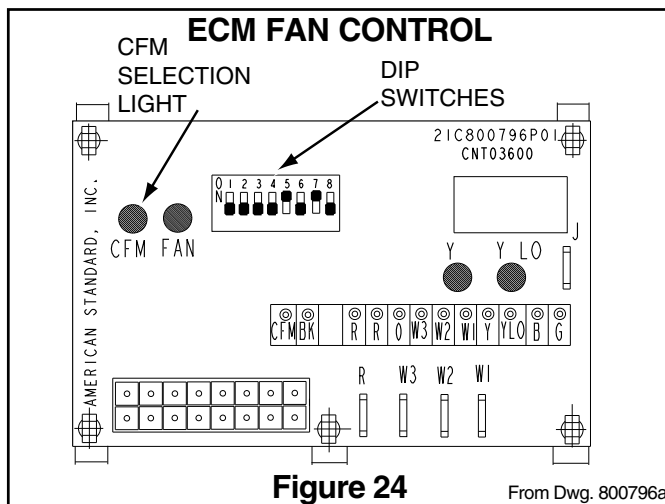
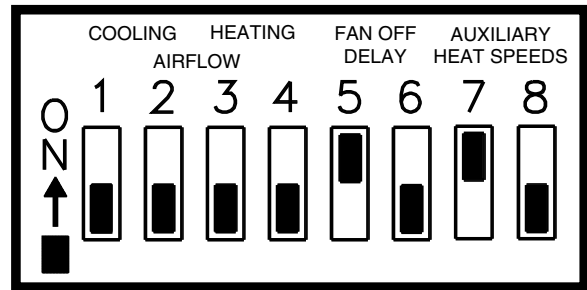

Figure 24

From Dwg. 800796a

Figure 25



DIP SWITCHES (AS SHIPPED)

insure that all packaging material has been removed.

J. AIRFLOW ADJUSTMENT

⚠ CAUTION

Disconnect power to the air handler before changing dip switch positions.

Failure to follow this procedure may result in equipment damage.

Blower speed changes are made on the ECM Fan Control mounted inside the control box. The ECM Fan Control controls the variable speed motor.

There is a bank of 8 dip switches (See Figure 24). The dip switches work in pairs to match the airflow for the outdoor unit size (tons), cooling airflow adjustment, Fan off-delay options, and heating airflow adjustment. The switches appear as shown in Figure 25.

If the airflow needs to be increased or decreased, see the Airflow Label on the air handler or the Blower Performance Table in the Service Facts. Information on changing the speed of the blower motor for your specific outdoor model size is in the Blower Performance Table. Be sure to set the airflow for the correct tonnage. Refer to blower housing for correct setting.

- Switches 1 - 4 Cooling Airflow
- Switches 5 - 6 Fan Off Delay Options
- Switches 7 - 8 Auxiliary Heat

If the optional humidistat is used, remove R-BK jumper from the low voltage terminal board (not shown) and install the humidistat between R and BK. (Jumper R to O for cooling-only/non-heat pump systems with a humidistat.)

INDOOR BLOWER TIMING

The FAN-OFF period is set on the ECM Fan Control board by dip switches #5 and #6. The blower off-delay settings are as follows:

IMPORTANT:

Leave dip switch 5 & 6 in the "as-shipped" position during system start-up and check out. Afterwards, adjust as desired.

Installer's Guide

FAN OFF - DELAY OPTIONS

| SWITCH SETTINGS | | SELECTION | NOMINAL AIRFLOW |
|-----------------|---------|-------------|-----------------|
| 5 - OFF | 6 - OFF | NONE | SAME |
| 5 - ON | 6 - OFF | 1.5 MINUTES | 100% * |
| 5 - OFF | 6 - ON | 3 MINUTES | 50% |
| 5 - ON | 6 - ON | ENHANCED** | 50 - 100% |

* - This setting is equivalent to the BAY24X045 relay benefit.

** - This ENHANCED MODE selection provides a ramping up and ramping down of the blower speed to provide improved comfort, quietness, and potential energy savings. The graph shows the ramping process.

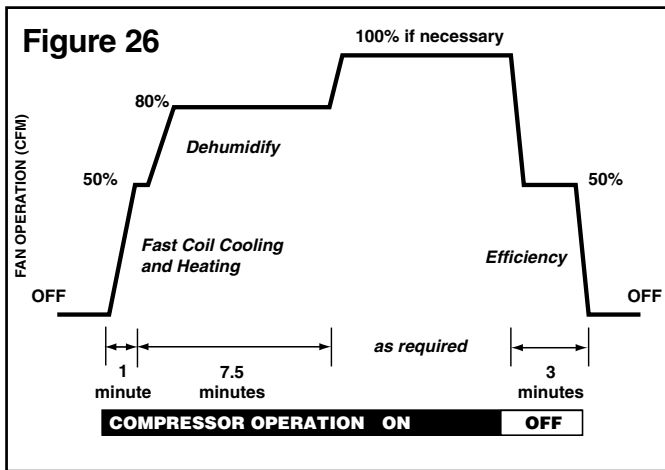

NOTE: Direct drive motors have bearings which are permanently lubricated and under normal use lubrication is not recommended.

K. CHECKOUT PROCEDURE

NOTE: In normal operation, the air cleaner makes a slight sound as the air passes through and is cleaned. In some applications, you may notice this sound coming from the return air vent(s). If desired, this sound level can be reduced with minimal impact on air cleaning efficiency by reducing the power setting of the FIELD CHARGER. The unit is shipped with the power set at 9.6KV (high). If sound is heard, reduce power level to 8.0KV (low) at the switch on the power supply. See Figure 27.

1. Check the air handler installation in accordance with the instructions on page 23.

L. INTEGRATED WHOLE HOUSE AIR CLEANER MAINTENANCE

1. For maximum efficiency the COLLECTION CELL should be inspected and cleaned on a regular basis.

NOTE: A 30 to 90 day cleaning interval is normal for the COLLECTION CELL and should be adjusted based upon unit run time and the home environment.

2. The FIELD CHARGER must be removed and cleaned only by a qualified service professional.
3. The FIELD CHARGER must be cleaned at least once a year.
4. The FIELD CHARGER may require more frequent cleaning in homes with high indoor relative humidity (greater than 65% RH).
5. Consult your service professional about cleaning intervals.

⚠ CAUTION

High Voltage is present within the air cleaner for operation. Before removing the Filter Door or Panel, turn the Comfort Control to the OFF position and disconnect all sources of power to the unit and wait at least 15 seconds to allow voltage to discharge.

⚠ WARNING

RISK OF ELECTRIC SHOCK:

These servicing instructions are for use by qualified service technician. To reduce the risk of electric shock, do not perform any servicing other than that contained in these operating instructions unless you are qualified to do so.

NOTE: System Information

Before cleaning the coil or ducts in the air handler, remove the COLLECTION CELL and FIELD CHARGER from the air cleaner. Chemicals used during the cleaning of the air handler or ductwork can damage the air cleaner components and degrade the performance of the air cleaner.

M. CLEANING THE COLLECTION CELL

1. Turn the air conditioning system off at the Comfort Control.
2. Loosen thumbscrews to remove the filter panel. Remove the COLLECTION CELL by pulling forward. See Figure 6.

CLEANING

The COLLECTION CELL may be cleaned either by vacuuming (recommended method) or by washing with water only.

VACUUM CLEANING

Remove COLLECTION CELL from conditioned space. Vacuum both sides of the COLLECTION CELL to clean.

WASHING

Use low-pressure water spray, such as a sink sprayer or garden hose to clean the COLLECTION CELL. Some residue may require warm water to be removed.

- Do NOT use soap or detergent in cleaning the COLLECTION CELL.
- Do NOT immerse the COLLECTION CELL completely

in water.

- Do NOT place the COLLECTION CELL into a dishwasher to clean.
- ALLOW THE COLLECTION CELL TO DRY THOROUGHLY BEFORE REINSTALLING.

Slightly tap the COLLECTION CELL to remove water retained. Allow the COLLECTION CELL to **completely** dry before reinstalling.

N. CLEANING THE FIELD CHARGER

1. Turn the air conditioning system to the off position at the Comfort Control. Loosen thumbscrews to remove the filter panel. Remove the COLLECTION CELL by pulling forward. See Figure 6.
2. Use a 5/16" nutdriver to remove the screws holding the FIELD CHARGER retainer bracket. See Figures 7 and 8.
3. Remove the FIELD CHARGER from the unit. Lay the FIELD CHARGER on a secured flat surface.

⚠ CAUTION

FIELD CHARGER PINS ARE SHARP. DO NOT BEND FIELD CHARGER PINS. WEAR APPROPRIATE GLOVES WHEN HANDLING THE FIELD CHARGER.

4. Wipe down the face plate of the FIELD CHARGER with a dry shop towel or use a vacuum cleaner.

NOTE: Do NOT disassemble the FIELD CHARGER.

5. Push a block of foam down over the FIELD CHARGER Pin as in Figure 28.
6. Rotate the foam block on the FIELD CHARGER Pin. See Figure 29.
7. Use the foam block to clean the faceplate opening edges.
8. Repeat steps 5,6 and 7 for each FIELD CHARGER Pin.
9. Put FIELD CHARGER back into the air handler and secure the FIELD CHARGER in place with the retainer bracket. See Figure 7.
10. Reinstall COLLECTION CELL.
11. Put filter panel back in place.

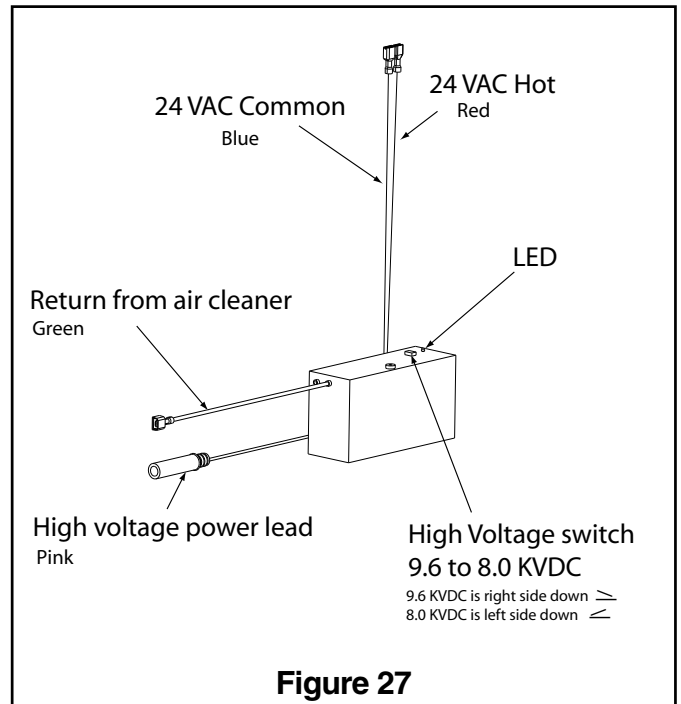

Figure 27

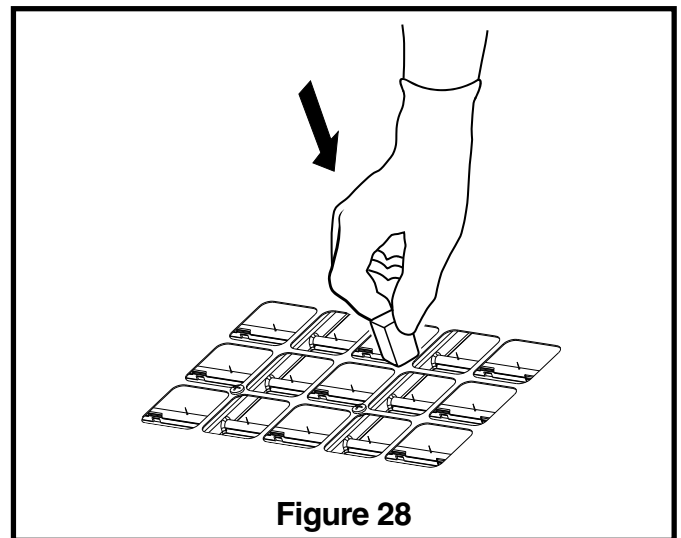

Figure 28

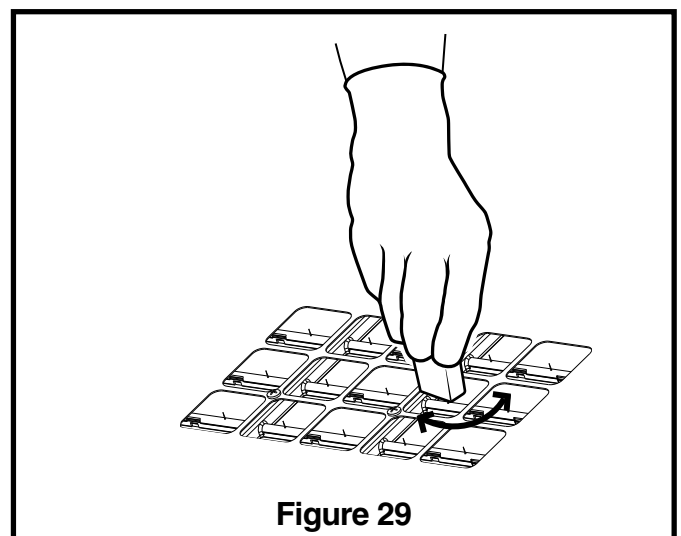
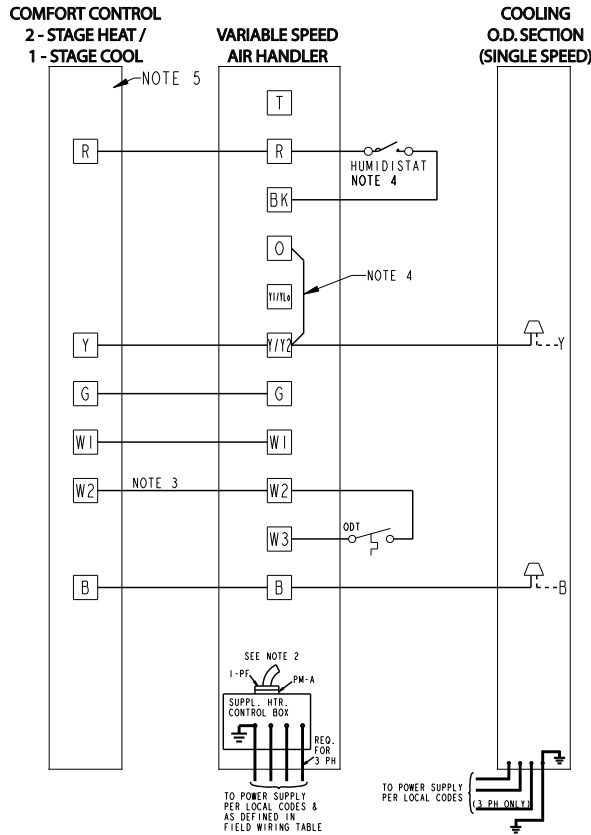

Figure 29

Installer's Guide

2/4TEE3D31, 37, 40, 49 & 65A AIR HANDLERS WITH SINGLE STAGE COOLING, 2 STAGE HEAT



NOTES:

1. LOW VOLTAGE WIRING TO BE NO. 18 A.W.G. MINIMUM CONDUCTOR.
2. WHEN HEATERS ARE USED, DISCARD POWER LEADS WITH POLARIZED PLUG PM-A AND CONNECT 1-PF TO MATING PLUG IN THE HEATER CONTROL BOX AS SHOWN.
3. TERMINAL W2 WILL HAVE INTERNAL CONNECTIONS ONLY IF 2ND CONTACTOR IS USED BY THE HEATER FOR CONTROLLING POWER TO ELECTRIC HEATING ELEMENTS. IF 2ND (BH) CONTACTOR IS NOT USED, THEN FIELD CONNECTIONS TO W2 CAN BE OMITTED AS APPROPRIATE.
4. CONNECTIONS TO "R", "BK", "O" AND "Y" MUST BE MADE AS SHOWN FOR PROPER OPERATION OF BLOWER WITH HUMIDISTAT IN COOLING.
5. SEE HEATER WIRING DIAGRAM FOR HEATING ANTICIPATOR SETTING.

INTER-COMPONENT WIRING

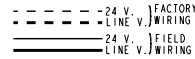

From Dwg. No. B801074

2/4TEE3D31, 37, 40, 49 & 65A AIR HANDLERS WITH TWO STAGE COOLING, 2 STAGE HEAT

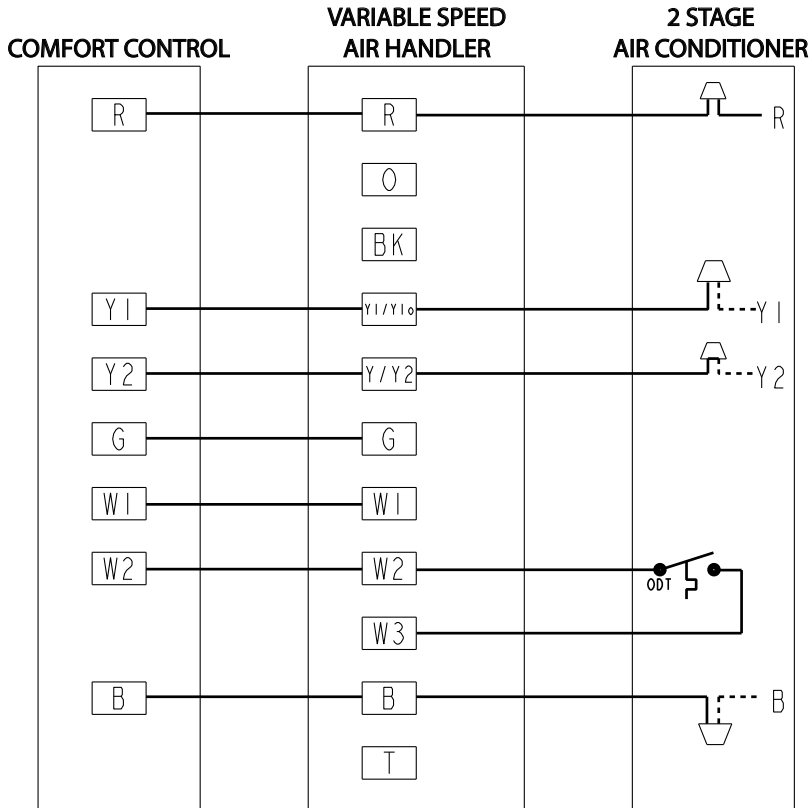

NOTES:

1. BE SURE POWER SUPPLY AGREES WITH EQUIPMENT NAMEPLATE.
2. POWER WIRING AND GROUNDING OF EQUIPMENT MUST COMPLY WITH LOCAL CODES.
3. LOW VOLTAGE WIRING TO BE NO. 18 AWG MINIMUM CONDUCTOR.
4. IF OUTDOOR THERMOSTAT (ODT) IS NOT USED, CONNECT W2 TO W3.

24V INTER-COMPONENT WIRING

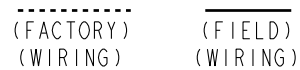

PRINTED FROM B152935P03

2/4TEE3D31, 37, 40, 49 & 65A AIR HANDLERS WITH SINGLE STAGE HEAT PUMP

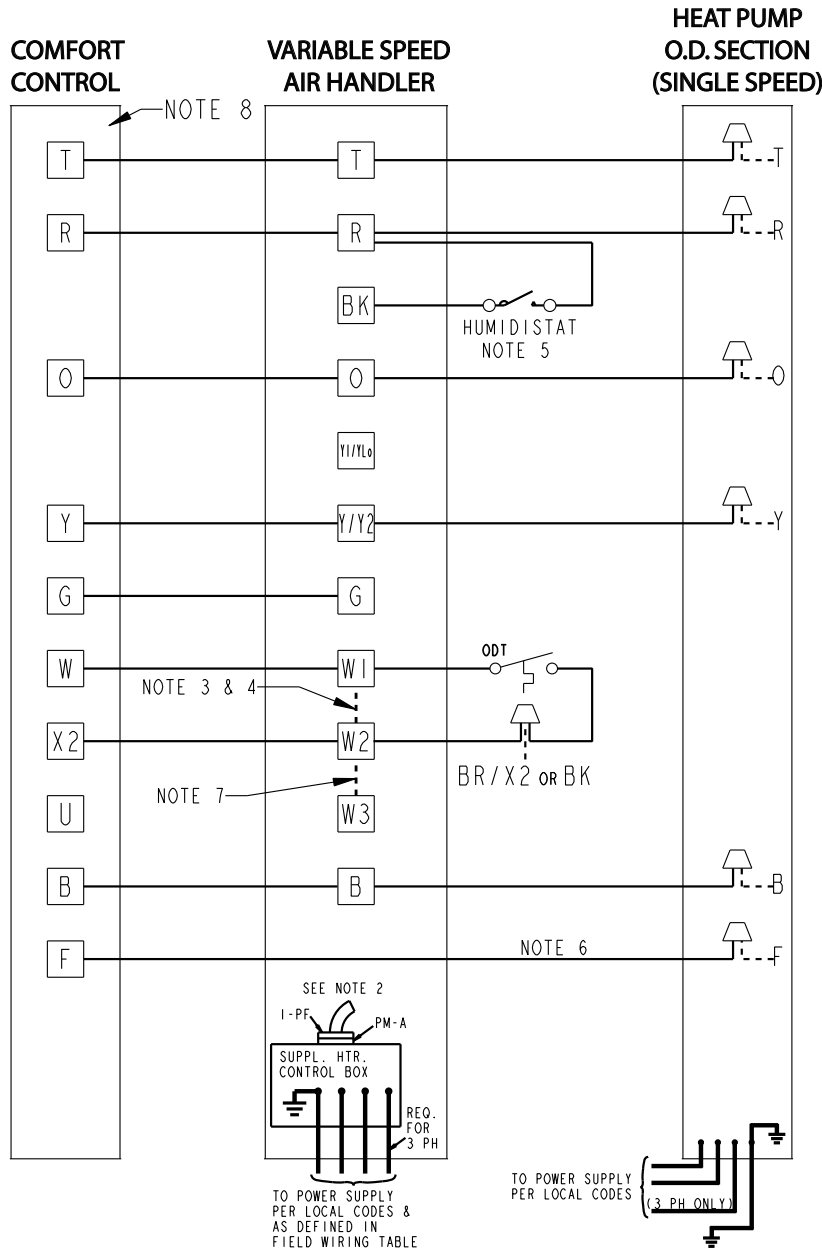

NOTES:

1. LOW VOLTAGE WIRING TO BE NO. 18 A.W.G. MINIMUM CONDUCTOR.
2. WHEN HEATERS ARE USED, DISCARD POWER LEADS WITH POLARIZED PLUG PM-A AND CONNECT I-PF TO MATING PLUG IN THE HEATER CONTROL BOX AS SHOWN.
3. TERMINAL W2 WILL HAVE INTERNAL CONNECTIONS ONLY IF 2ND CONTACTOR IS USED BY THE HEATER FOR CONTROLLING POWER TO ELECTRIC HEATING ELEMENTS. IF 2ND (BH) CONTACTOR IS NOT USED, THEN FIELD CONNECTIONS TO W2 CAN BE OMITTED AS APPROPRIATE.
4. IF ODT IS NOT USED, THEN CONNECT APPROPRIATE JUMPER FROM W1 TO W2 TO W3 ON LVTB.
5. IF HUMIDISTAT IS NOT USED, CONNECT JUMPER FROM "R" TO "BK" FOR FULL TONNAGE AIRFLOW IN COOLING.
6. CONNECT IN THIS MANNER IF O.D. UNIT HAS "F" CONNECTION.
7. CONNECT W3 TO W2 ONLY IF USING HEATER WITH 3 HEATER STAGES.
8. SEE HEATER WIRING DIAGRAM FOR HEATING ANTICIPATOR SETTING.

From Dwg. No. B801077

Installer's Guide

OUTLINE DRAWING FOR 2/4TEE3D31, 37, 40, 49 & 65A1000A

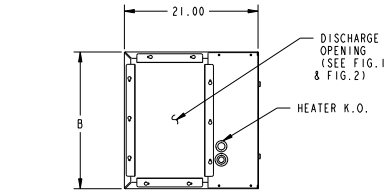

TOP VIEW

.88" X 1.38" DUCT FLANGES (SEE FIG. 1 & FIG. 2) REVERSIBLE

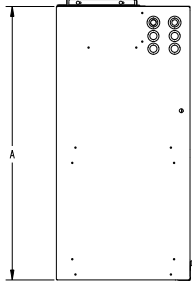

SIDE VIEW

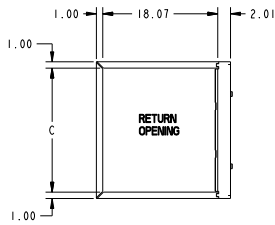

BOTTOM VIEW

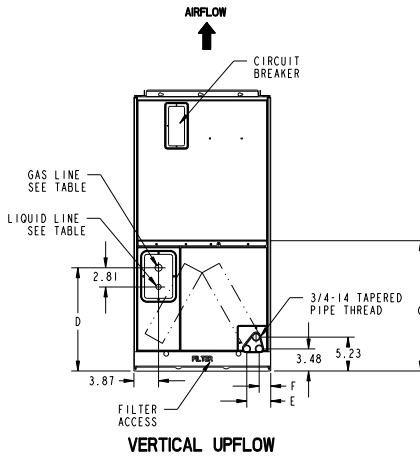

VERTICAL UPFLOW

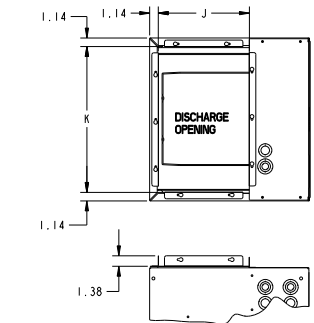

FIG. 1

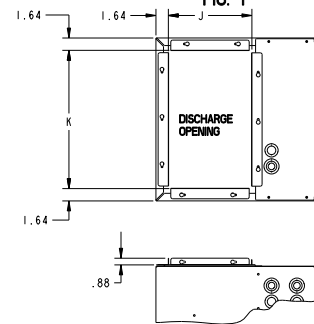

FIG. 2

| MODEL NO. | FIG. 1 | | FIG. 2 | |
|--|--------|------|--------|------|
| | J | K | J | K |
| 2TEE3D31, 4TEE3D31 2TEE3C31, 4TEE3C31 | | 19.5 | | 18.5 |
| 2TEE3D37, 2TEE3F39, 4TEE3D37, 4TEE3F39 2TEE3C37, 2TEE3F48, 4TEE3C37, 4TEE3F48 2TEE3F64, 4TEE3F64 | 12.0 | 21.5 | 11.0 | 20.5 |
| 2TEE3D40, 4TEE3D40, 2TEE3C40, 4TEE3C40 2TEE3D49, 4TEE3D49, 2TEE3C49, 4TEE3C49 2TEE3D65, 4TEE3D65, 2TEE3C65, 4TEE3C65 | | 24.0 | | 23.0 |

| | TO COMBUSTIBLE MATERIAL (REQUIRED) | SERVICE CLEARANCE (RECOMMENDED) |
|-------------|------------------------------------|---------------------------------|
| SIDES | 0" | 2" |
| FRONT | 0" | 21" |
| BACK | 0" | 0" |
| INLET DUCT | 0" | 1" |
| OUTLET DUCT | 1" | 1" |

* 1" FOR THE FIRST 3 FT. OF OUTLET DUCT WHEN ELECTRIC HEATERS ARE INSTALLED.

| MODEL NO. | A | B | C | D | E | F | G | FLOW CONTROL | GAS LINE BRAZE | LIQ. LINE BRAZE |
|--|-------|-------|-------|-------|------|------|-------|--------------|----------------|-----------------|
| 2TEE3D31, 4TEE3D31 2TEE3C31, 4TEE3C31 | 43 | 21.50 | 19.50 | 15.57 | 3.62 | 1.89 | | | 3/4 | 5/16 |
| 2TEE3D37, 2TEE3C37 | 45 | 23.50 | 21.50 | 17.57 | | | N/A | | 7/8 | |
| 2TEE3D40, 2TEE3C40 | 51.75 | | | 18.33 | | | | | 7/8 | |
| 2TEE3D49, 2TEE3C49 | 57.90 | 26 | 24 | 27.12 | 3.21 | 1.48 | | | 1-1/8 | |
| 2TEE3D65, 2TEE3C65 | 62.75 | | | | | | 36.00 | | 1-1/8 | |
| 4TEE3D37, 4TEE3C37 | 45 | 23.50 | 21.50 | 17.57 | 3.62 | 1.89 | | | 3/4 | |
| 4TEE3D40, 4TEE3C40 | 51.75 | | | 18.33 | | | N/A | TXV/NB | 3/4 | 3/8 |
| 4TEE3D49, 4TEE3C49 | 57.90 | 26 | 24 | 27.12 | 3.21 | 1.48 | | | 7/8 | |
| 4TEE3D65, 4TEE3C65 | 62.75 | | | | | | 36.00 | | 7/8 | |
| 2TEE3F39 | 57.90 | | | 17.00 | | | 31.15 | | 3/4 | |
| 4TEE3F39 | | | | | 3.62 | 1.89 | | | 1-1/8 | |
| 2TEE3F48, 2TEE3F64 | 57.90 | 23.50 | 21.50 | | | | 31.15 | | 7/8 | |
| 4TEE3F48, 4TEE3F64 | | | | 26.77 | | | | | 7/8 | |

From Dwg. D802101 Rev. 5

2/4TEE3D31, 37, 40, 49 & 65A AIR HANDLER DIMENSIONAL DATA

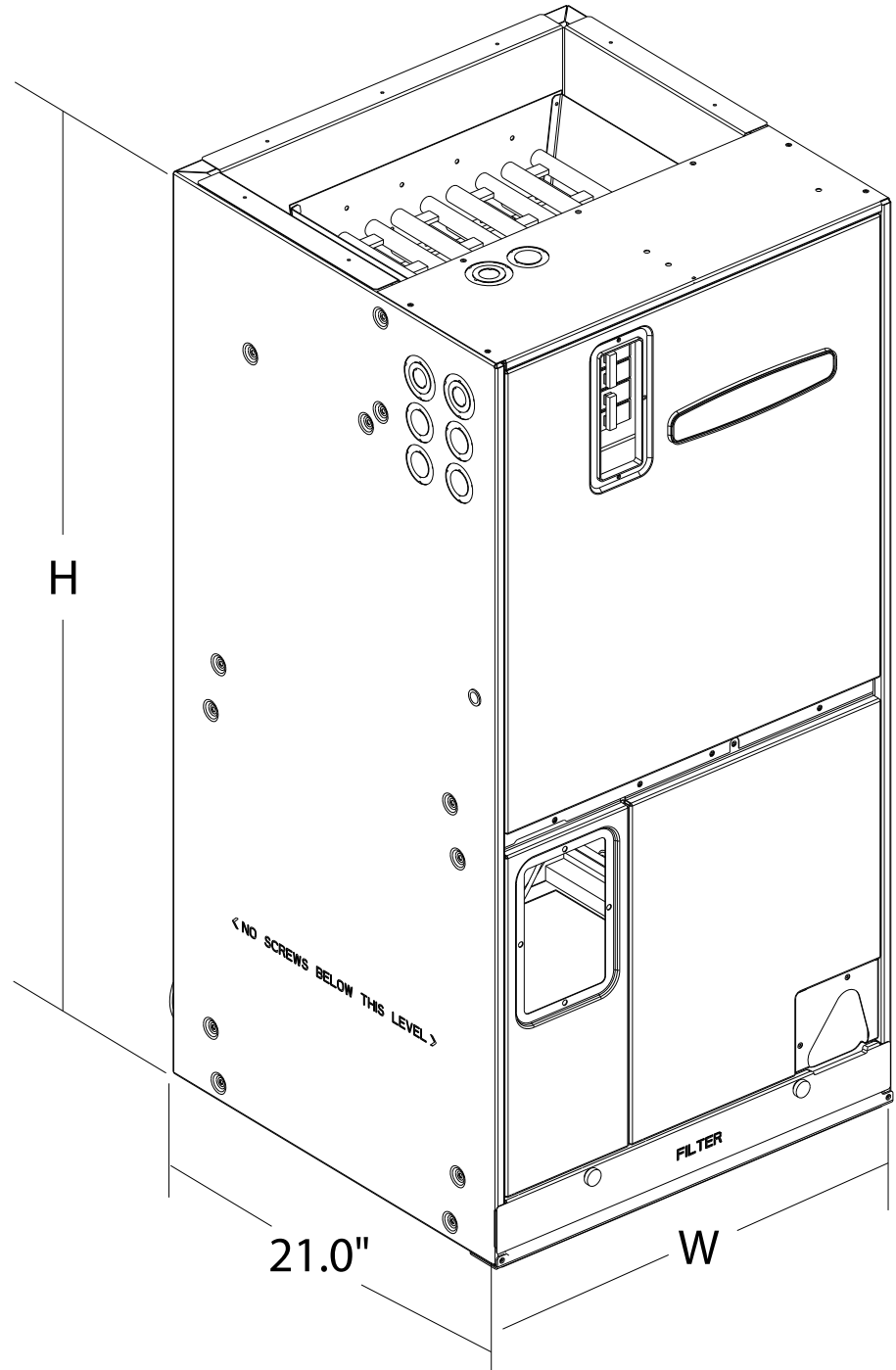

| Model No. | H | W |
|-------------|-------|-------|
| 2/4TEE3D31A | 43.00 | 21.50 |
| 2/4TEE3D37A | 45.00 | 23.50 |
| 2/4TEE3D40A | 51.75 | 26.00 |
| 2/4TEE3D49A | 57.90 | 26.00 |
| 2/4TEE3D65A | 62.75 | 26.00 |

Installer's Guide

EXPLODED VIEW

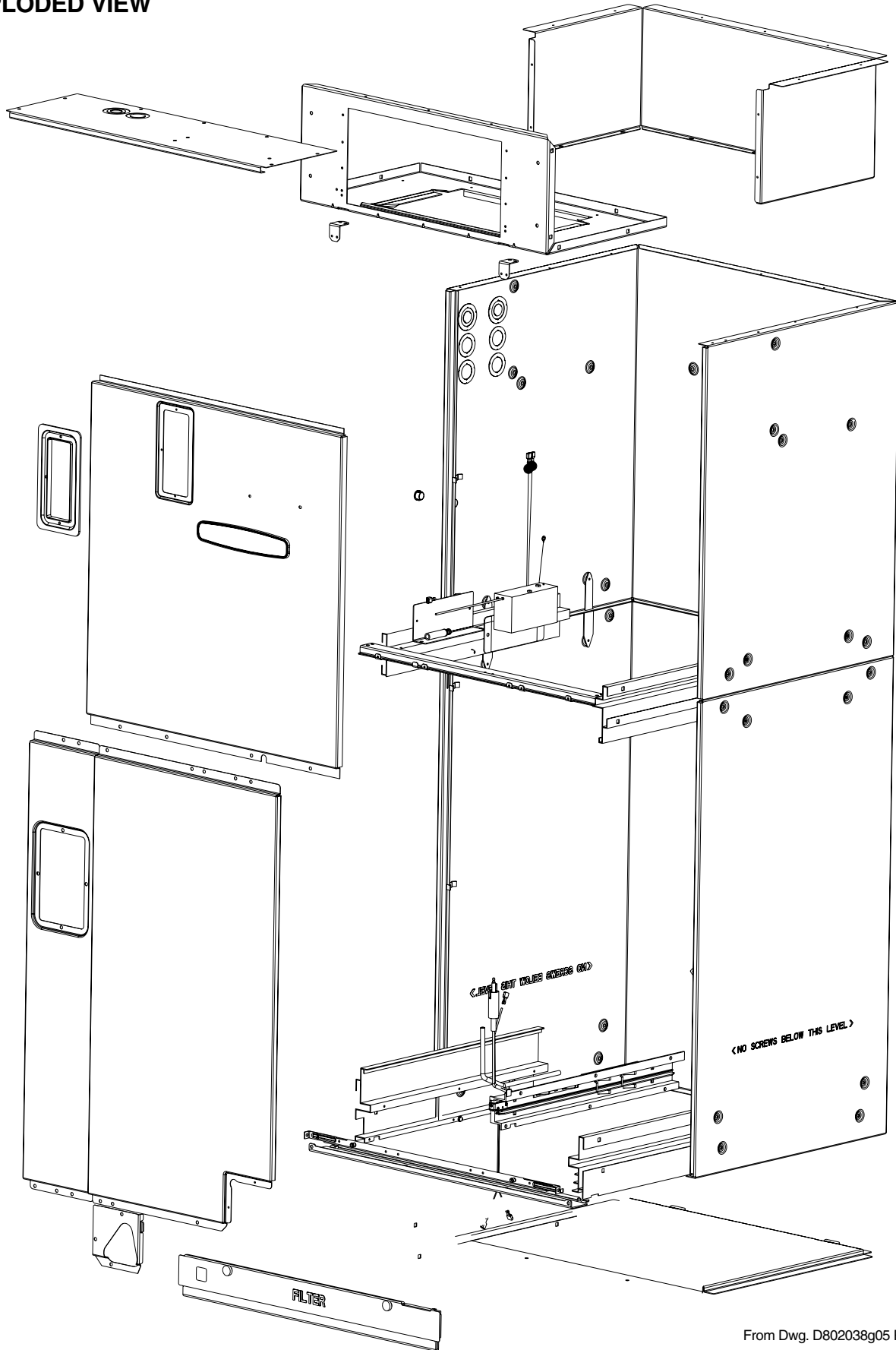

From Dwg. D802038g05 Rev. 11

CHECKOUT PROCEDURES

After installation has been completed, it is recommended that the Air Handler be checked against the following checklist.

1. Make sure power is "OFF" at power disconnect switch []
 2. Check all field wiring for tight connections. See that grounding of unit is in accord with code []
 3. Make sure unit suspension (if used) is secure and that there are no tools or loose debris in, around or on top of the unit []
 4. Check all duct outlets; they must be open and unrestricted []
 5. Check drain lines and be sure all joints are tight []
 6. Make sure secondary drain pan is installed []
 7. Check power supply for correct requirements per unit nameplate []
 8. Inform owner of proper procedure for cleaning COLLECTION CELL []
 9. Energize the system and carefully observe its operation; make any necessary adjustment []
 10. Instruct owner on proper operating procedure and leave Use and Care Manual with owner []
 11. Check the integrated whole electronic air cleaner power output by the Green LED illumination. If the LED is on, this indicates High Voltage output to the air cleaner. []
 12. Check to make sure the electronic air cleaner is working. []
- a) Turn off Comfort Control.
 - b) Remove air handler top panel.
 - c) Disconnect the 5-pin High Voltage connector to the variable speed motor.

WARNING

**RISK OF ELECTRICAL SHOCK:
ELECTRICAL POWER IS PRESENT FOR THE NEXT 5 STEPS. THESE STEPS SHOULD BE PERFORMED ONLY BY QUALIFIED SERVICE TECHNICIAN. FAILURE TO FOLLOW THIS WARNING COULD RESULT IN PERSONAL INJURY, ELECTRICAL SHOCK, OR DEATH.**

- d) Turn the system power On.
- e) Turn the Comfort Control to the Fan only position.
- f) Check for LED illumination on the power supply to the air cleaner. LED illumination indicates High Voltage power is present to the air cleaner.
- g) Turn the Comfort Control to the Off position.
- h) Turn the system power Off.
- i) Reconnect the 5-pin High Voltage connector to the variable speed motor.
- j) Replace the air handler top panel.
- k) Turn the Comfort Control back on.

SUPPLEMENTARY HEATERS CHECKOUT PROCEDURES,

IF a heater is USED, see "limitations and recommendations" to determine if the heater requires a SPECIAL CIRCUIT.

1. Be sure the disconnect switch is "OFF", and safety label (if any) is attached []
2. Check on field wiring for tight connections and grounding according to codes []
3. Check circuit protection for proper size per nameplate specifications []
4. Check control box panel — in place and secured []

NOTE: OPERATION OF HEATERS MUST BE CHECKED DURING THE OPERATION CHECK OF THE TOTAL SYSTEM.

Trane
6200 Troup Highway
Tyler, TX 75707

*For more information contact
your local dealer (distributor)*

02/08

The manufacturer has a policy of continuous product and product data improvement, and it reserves the right to change design and specifications without notice.