

Convertible Air Handlers

2 – 5 Ton

4TEC3F24B1000A

4TEC3F48B1000A

4TEC3F36B1000A

4TEC3F60B1000A

4TEC3F42C1000A

⚠ WARNING: HAZARDOUS VOLTAGE - DISCONNECT POWER BEFORE SERVICING

ALL phases of this installation must comply with NATIONAL, STATE AND LOCAL CODES

IMPORTANT—This Document is **customer property** and is to remain with this unit. Please return to service information pack upon completion of work.

A. GENERAL INFORMATION

⚠ WARNING

SAFETY HAZARD

THIS INFORMATION IS FOR USE BY INDIVIDUALS HAVING ADEQUATE BACKGROUNDS OF ELECTRICAL AND MECHANICAL EXPERIENCE. ANY ATTEMPT TO REPAIR A CENTRAL AIR CONDITIONING PRODUCT MAY RESULT IN PERSONAL INJURY AND/OR PROPERTY DAMAGE. THE MANUFACTURER OR SELLER CANNOT BE RESPONSIBLE FOR THE INTERPRETATION OF THIS INFORMATION, NOR CAN IT ASSUME ANY LIABILITY IN CONNECTION WITH ITS USE.

⚠ CAUTION

To prevent shortening its service life, the air handler should not be used during the finishing phases of construction. The low return air temperatures can lead to the formation of condensate. Condensate in the presence of chlorides and fluorides from paint, varnish, stains, adhesives, cleaning compounds, and cement creates a corrosive condition which may cause rapid deterioration of the cabinet and internal components.

These instructions do not cover all variations in systems or provide for every possible contingency. Should further information be desired or particular problems arise which are not covered sufficiently by this manual, contact your local distributor or the manufacturer as listed on the air handler nameplate.

These air handlers are shipped from the factory in the upflow or horizontal right configuration and are fully convertible to downflow or horizontal left. Refer to Section B beginning on page 3 for additional information.

INSPECTION

Check carefully for any shipping damage. This must be reported to and claims made against the transportation company immediately. Check to be sure all major components are in the unit. Any missing parts should be reported to your supplier at once, and replaced with authorized parts only.

Contents

General Information	1
Unit Installation	3
Upflow	3
Downflow	4
Horizontal Left	6
Horizontal Right	7
Duct Connections	8
Refrigerant Piping	8
Brazing to Evaporator	8
Condensate Drain Piping	9
Electrical — Power Wiring	10
Control Wiring	10
Hook-up Diagrams	11
Outline Drawing	14
Checkout Procedures	16

⚠ CAUTION

Cardboard packing material must be removed from inside the blower assembly before starting the unit. Failure to do so may cause indoor blower motor failure.

INSTALLATION LIMITATIONS & RECOMMENDATIONS

The general location of the air handler is normally selected by the architect, contractor and/or home owner for the most effective application and satisfaction.

NOTE: CONDENSATION MAY OCCUR ON THE SURFACE OF THE AIR HANDLER WHEN INSTALLED IN AN UNCONDITIONED LOCATION. WHEN UNITS ARE INSTALLED IN UNCONDITIONED SPACES, VERIFY THAT ALL ELECTRICAL AND REFRIGERANT LINE PENETRATIONS ON THE AIR HANDLER ARE SEALED COMPLETELY.

Installer's Guide

These air handlers are suitable for installation in a closet, alcove or utility room with free, non-ducted, air return, using the area space as a return air plenum. With ducted supply air, if the minimum clearances to combustible materials and service access are observed, the above installations are suitable.

This area may also be used for other purposes, including an electric hot water heater – **but in no case shall a fossil fuel device be installed and/or operated in the same closet, alcove or utility room.**

In addition, these air handlers are suitable for installation in an attic, garage or crawl space with ducted supply and return air.

This equipment has been evaluated in accordance with the Code of Federal Regulations, Chapter XX, Part 3280 or the equivalent. "SUITABLE FOR MOBILE HOME USE."

For proper installation the following items must be considered:

1. If adequate power is available and correct according to nameplate specifications.
2. Insulate all ducts, particularly if unit is located outside of the conditioned space.
3. Pursuant to Florida Building Code 13-610.2.A.2.1, this unit meets the criteria for a factory sealed air handler.
4. To ensure maximum efficiency and system performance, the existing supply and return duct system static pressures must not exceed the total available

static pressure of the air handler. Reference ACCA Manual D, Manual S and Manual RS along with the air handler Product Data and Service Facts for additional information.

5. The area around refrigerant lines must be sealed and electrical inlets need to be sealed at both the low and the high voltage.
6. It is recommended that the outline drawing be studied and dimensions properly noted and checked against selected installation site. By noting in advance which knockouts are to be used, proper clearance allowances can be made for installation and possible future service.
7. Allow a **minimum of 21 inches clearance** in front of the air handler to permit service and removal of filter.
8. When air handler with supplementary heater is to be installed in the downflow position on combustible flooring an accessory subbase (TAYBASE101 for 4TEC3F24-36B or TAYBASE100 for 4TEC3F42B-60B) must be used. See Figure 1.
9. If supplementary heat is to be added, power supply must be sufficient to carry the load. In addition, minimum air flow settings, unit and duct clearances to combustible material must be maintained as stated on the air handler rating nameplate.

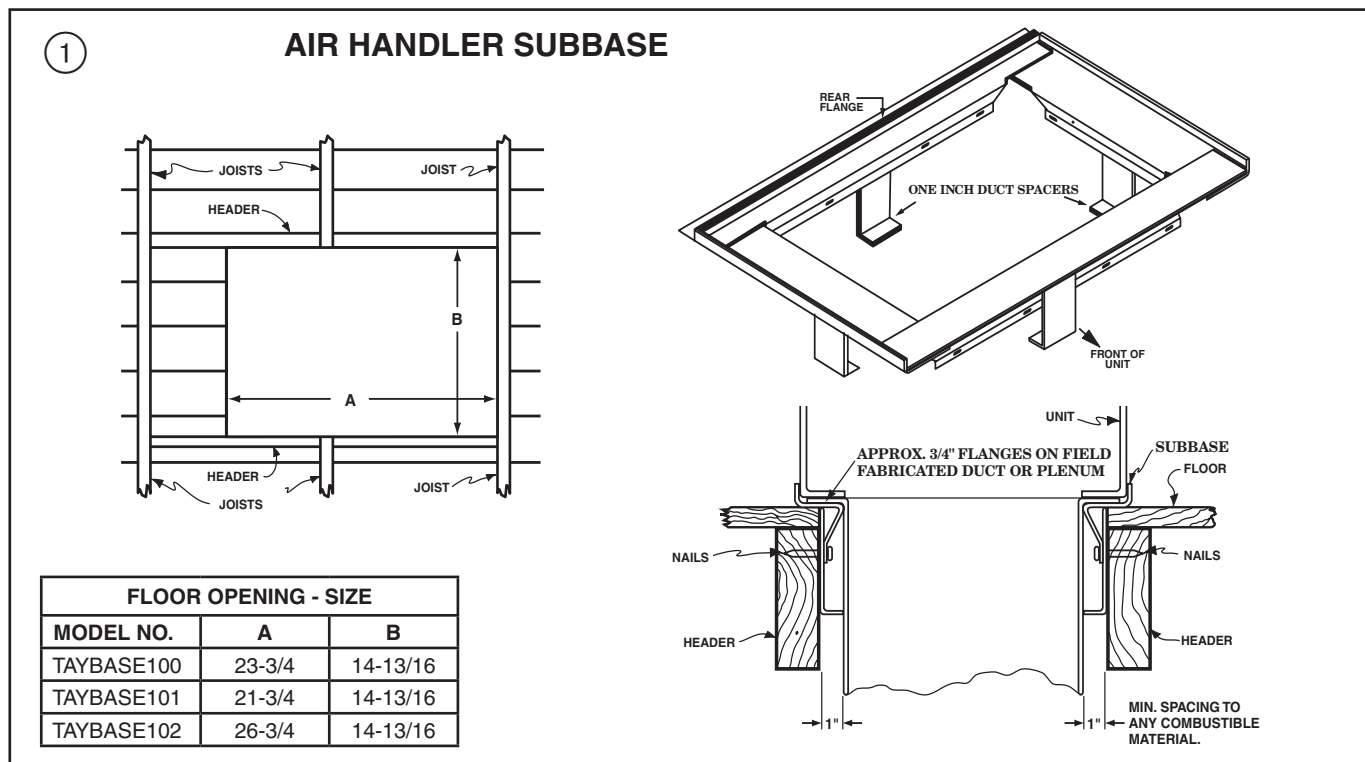

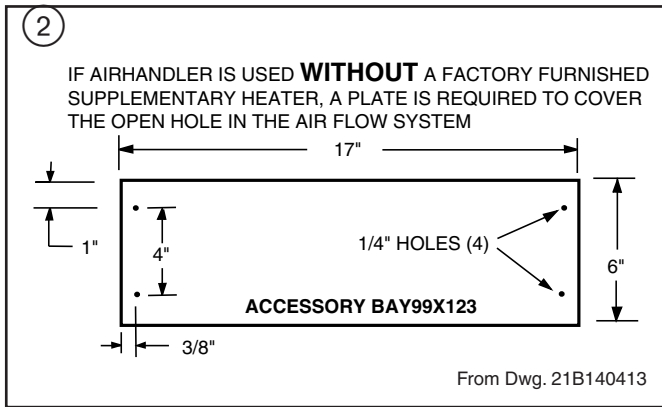

⚠ CAUTION

For air handlers not equipped with a factory installed electric heater, a field installed heater is available from Trane. Only heaters built by Trane are approved for use in the air handler. These heaters have been designed and tested in accordance with UL standards to provide safe and reliable operation. A list of approved heaters is provided on the air handler rating nameplate. Heaters that are not factory approved could cause damage and are not covered under equipment warranty.

NOTE: If air handler is used WITHOUT a supplementary electric heater, a sheetmetal plate is required to cover the open hole in the airflow system. See Figure 2. Also seal the cabinet air tight where the wire enters.

10. If the unit is installed without a return air duct, applicable local codes may limit this air handler to installation only in a single story residence and within conditioned space.
11. If the outdoor unit is to be installed later, or by others, then installation of the air handler must be made to allow access for refrigerant lines, or attach refrigerant lines to air handler when installing.
12. Make sure there are provisions for installing condensate drain lines.
13. If side, front or rear return is required, air handler must be elevated or placed on a plenum (TAY-PLNM100 for 4TEC3F24 - 60B). Connecting return duct directly to the side, front or rear of the cabinet is not approved.
14. Route refrigerant and condensate drain lines away from air handler so they do not interfere with access panels and filters.
15. When external accessories are used, the additional height and width requirements must be considered in the overall space needed.
16. These units are not approved for outdoor installation.
17. These units are approved for draw-through application only.

NOTE: No atomizing style humidifier is allowed in the return plenum with the use of this unit.

18. Flow-through Bypass Humidifiers

Excessive bypass air may cause water blow-off, which will adversely affect system operation and air cleaner performance. To verify bypass airflow, follow the Bypass Humidifier Pre-Installation Check-out and Set-Up Procedures available through your local distributor. Ask for publication number 18-CH37D1-1.

Steam and Flow-through Fan Power Duct-mounted Humidifiers

Follow the humidifier installation instructions. These should only be installed on the supply air side of the system.

B. TWO PIECE CABINET DISASSEMBLY (OPTIONAL)

NOTE: For easier installation into tight areas, the 4 and 5 ton air handlers can be disassembled and reassembled after moved to an attic or other space.

Steps for disassembly and reassembly (See Figures 3 and 4)

1. Disconnect wiring.
2. Remove center bracket.
3. Remove blower assembly.
4. Remove coil.
5. Cut foil tape - minimum 3" foil tape.
6. Remove top 8 screws. See Figure 3.
7. Lift upper section.
8. Set air handler in place.
9. Attach screws - insure gaskets are aligned along flange.
10. Use foil tape to seal - use minimum 3" foil tape.
11. Insert coil.
12. Reinstall blower assembly.
13. Reinstall center bracket.
14. Reconnect wiring.

NOTE: In Downflow, remove coil before blower by reversing steps 4 and 5.

C. UNIT INSTALLATION

UPFLOW

- a. **For maximum efficiency**, the horizontal drip tray should be removed. See Figures 6, 7 and 8. Drip tray removal requires that the coil be removed by sliding the coil out on the coil channel supports. The drip tray is detached by removing the two screws at the drain pan and the two screws holding the two brackets at the top of the coil. Remove the two screws holding the two brackets at the top of the coil. Remove drip tray by gently breaking the seal between the drip tray and drain pan.

Installer's Guide

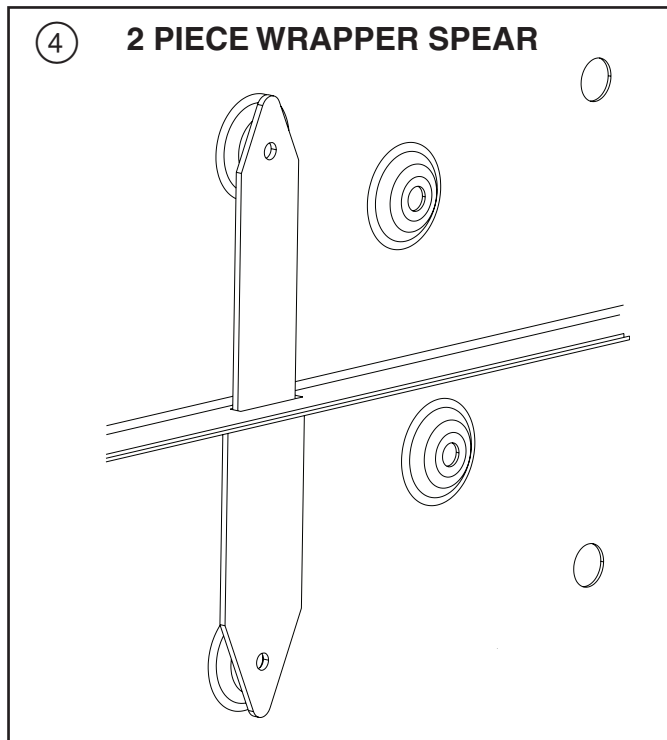
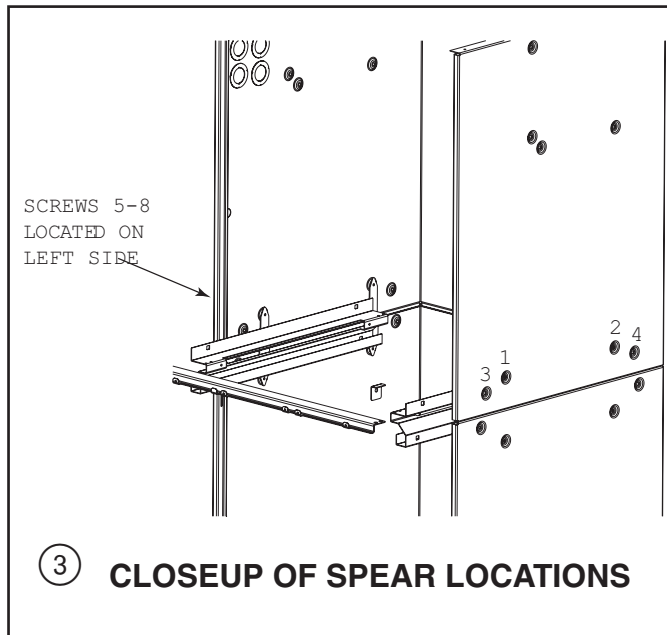

b. Remove the factory installed baffle assembly from the apex of the coil by using a 5/16" nut-driver to remove the screws. Replace this baffle with the factory supplied narrow coil baffle using the screws removed previously (See Figure 5). Reinstall coil assembly.

⚠ CAUTION

When installing the narrow coil baffle, make sure to align the baffle up with the holes so NOT to puncture the coil tubing.

- c. Position unit on Pedestal or other suitable foundation. If Pedestal is not used, a frame strong enough to support the total weight must be provided. Provide a minimum height of 14 inches for proper unrestricted airflow.

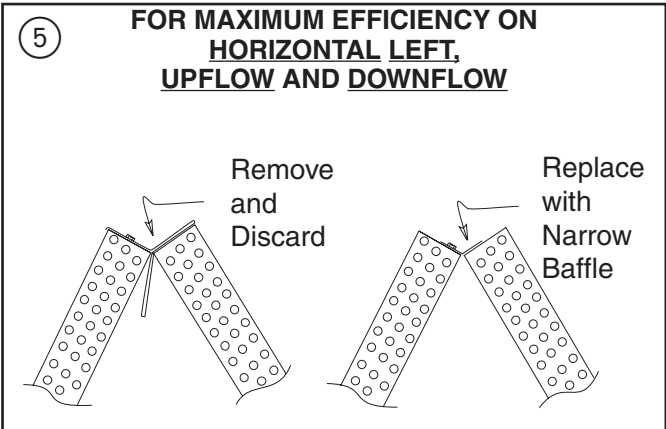

- d. If a return air duct is connected to the air handler, it must be the same dimensions as shown in the outline drawing.
- e. On units with sheetmetal returns: Return plenum should be flanged. Sheetmetal screws must be 1/2" in length or shorter.
- f. No sheetmetal screws may be used to attach return duct work on the side of the unit.
- g. Pedestal and unit should be isolated from the foundation using a suitable isolating material.
- h. **Openings where field wiring enters the cabinet must be completely sealed.** Location of power entry is shown on the outline drawing. Use 2.5" clear stickers to seal all unused electrical knockouts. See Figure 11.
- i. After ductwork connections are made, seal airtight and per local codes.

DOWNFLOW

- a. **For maximum efficiency**, the horizontal drip tray should be removed. See Figures 6, 7 and 8. Tray removal requires that the coil be removed by sliding the coil out on the coil channel supports. The tray is detached by removing the two screws at the drain pan and the two screws holding the two brackets at the top of the coil. Remove drip tray by gently breaking the seal between the drip tray and drain pan.

- b. Remove the factory installed baffle assembly from the apex of the coil by using a 5/16" nut-driver to remove the screws. Replace this baffle with the factory supplied narrow coil baffle using the screws removed previously (See Figure 5).

⚠ CAUTION

When installing the narrow coil baffle, make sure to align the baffle up with the holes so NOT to puncture the coil tubing.

NOTE: INSTALLATION OF THE DOWNFLOW BAFFLE KIT INCLUDED WITH UNIT IS REQUIRED ON DOWNFLOW APPLICATIONS. SEE FIGURE 9.

- c. Remove front shield by removing screws on right side. Make sure to reinstall front shield after baffle changes. See Figure 9.
- d. Detach the coil from the drain pan by removing 4 screws as shown in Figure 9.
- e. Remove the front triangular baffle from the coil and install the 1/2" wide gasket provided per Figure 9. Trim the gasket length to fit the baffle. Reinstall the baffle to coil, with gasket material compressed against the coil.
- f. Install the water blow-off baffles provided on each side of the coil with the flange at the top as shown in Figure 9. The bottom of the baffle is to be as close to the bottom of the coil as possible.
- g. Install the 7/8" wide gasket in each side of the drain pan as shown in Figure 9.

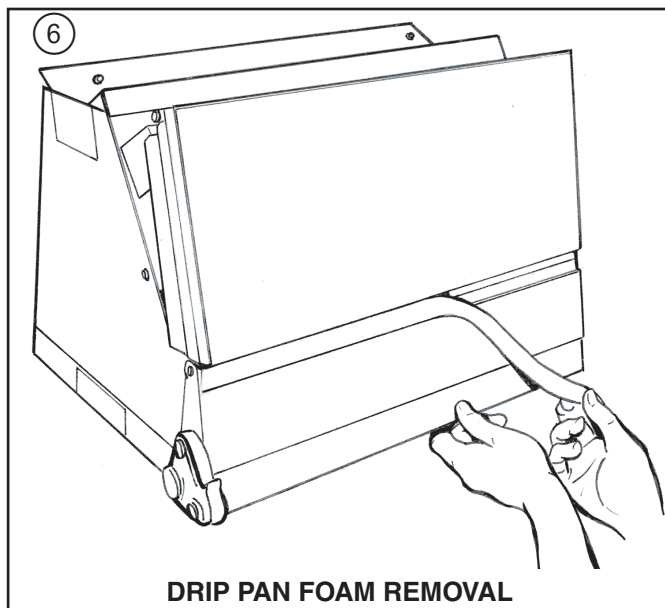

- h. Place the 2 water diverter baffles (**5 ton model only**) underneath the coil on the inside edge of the drain pan, Figure 9. Fill the bend in the baffle which fits the inner edge of the drain pan with non-acetic acid RTV type adhesive/sealant before installing the baffle.
- i. The unit is then placed with the blower side down and the coil is replaced on the coil channel supports with the drain connections at the bottom. The unit is now in downflow position with front access. Do not reattach coil support tab.
- j. When air handler with supplementary heater is to be installed in the downflow position on combustible flooring an accessory subbase (TAYBASE101 for 4TEC3F24B-36B or TAYBASE100 for 4TEC3F42B-60B) must be used. See Figure 1.

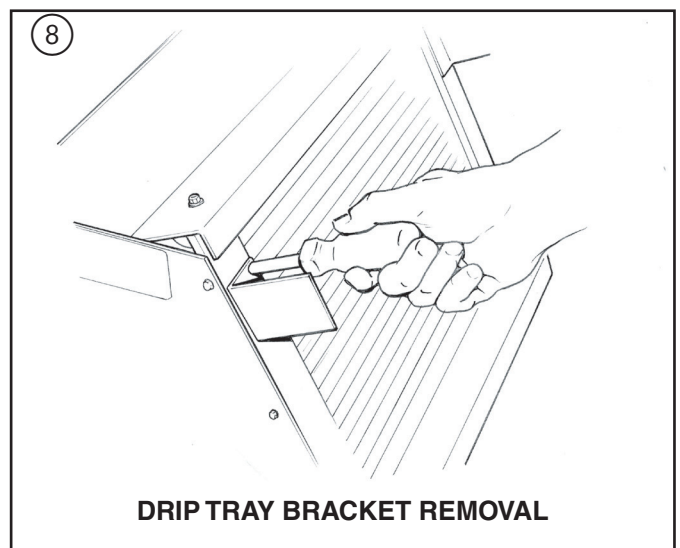
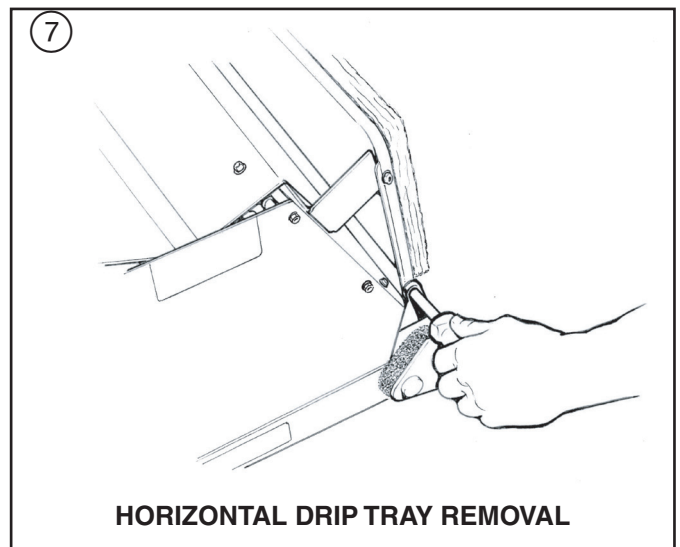

Installer's Guide

- k. If a return duct is connected to the air handler, it must be the same dimensions as the return opening shown in the outline drawing.
- l. On units with sheet metal returns: Return plenum should be flanged. Sheetmetal screws must be 1/2" in length or shorter.
- m. No sheetmetal screws may be used to attach return ductwork on the side of the unit.
- n. **Openings where field wiring enters the cabinet must be completely sealed.** Location of power entry is shown on the outline drawing. Use 2.5" clear stickers to seal all unused electrical knockouts. See Figure 11.
- o. After ductwork connections are made, seal airtight and per local codes.

HORIZONTAL LEFT

- a. To convert the unit to horizontal left, front access, slide the coil out on the coil channel supports and rotate the complete coil 180 degrees.
- b. **For maximum efficiency** and Customer ease of filter maintenance, it is recommended that a properly sized **remote filter** grille be installed for horizontal applications. Airflow should not exceed the face velocity of the filter being used.

The factory installed filter should then be removed from the unit. Remove the factory installed baffle assembly from the apex of the coil by using a 5/16" nutdriver to remove the hex head screws. Replace this baffle with the factory supplied narrow coil baffle using the screws removed previously. See Figure 5.

⚠ CAUTION

When installing the narrow coil baffle, make sure to align the baffle up with the holes so NOT to puncture the coil tubing.

- c. The coil is then inserted back into the cabinet on the opposite side coil channel supports. The unit is now horizontal left with front access. Do not reattach coil support tab.
- d. If the unit is suspended, it must be supported from the bottom near both ends as well as the middle to prevent sagging. The service access must remain unobstructed. If the unit is supported along the length of the front and back with rails, the air handler only needs to be suspended at both ends. See Figure 10.

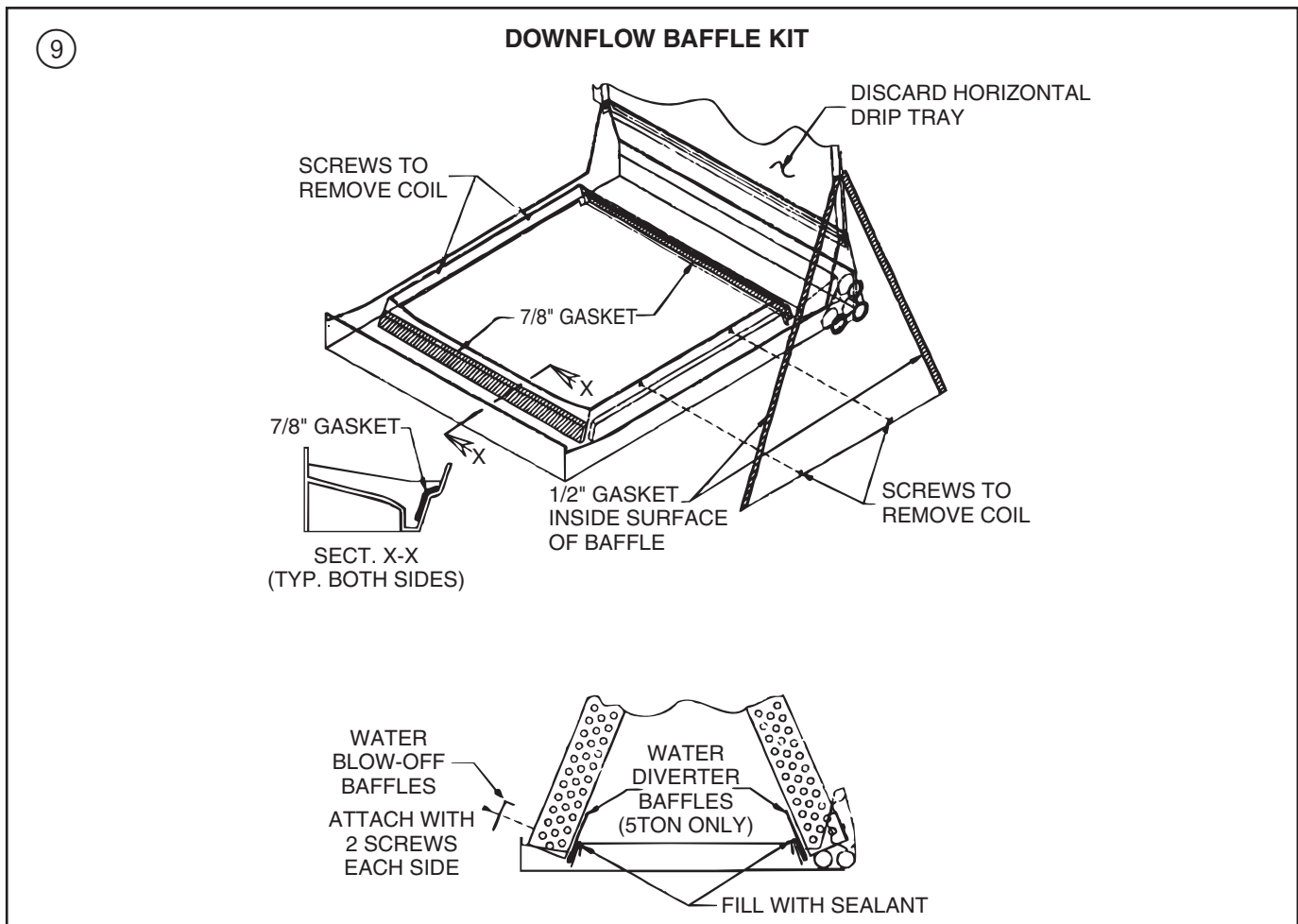

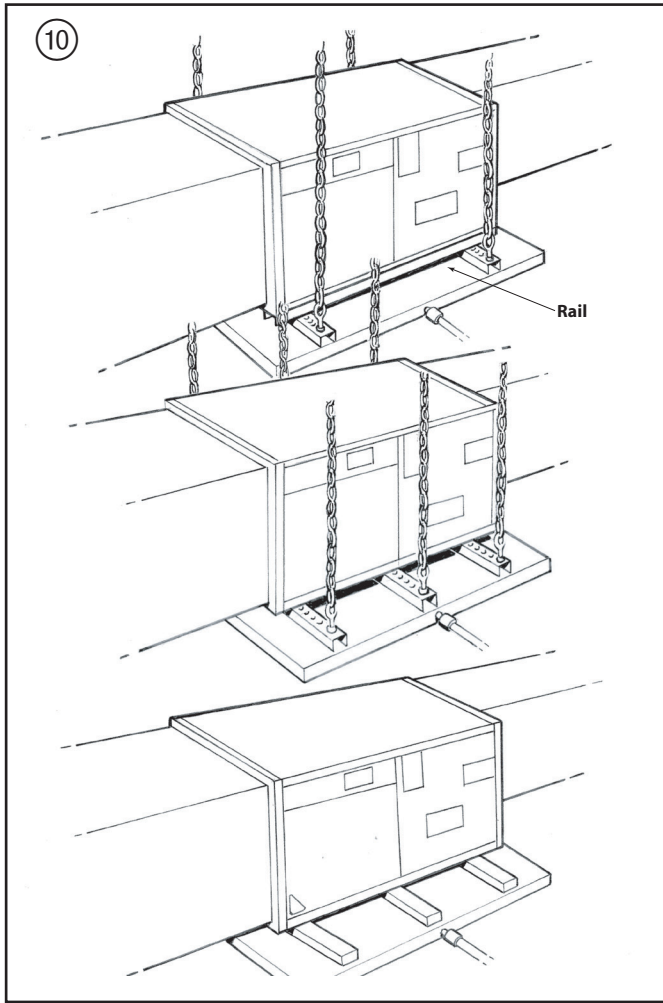

If the unit is not suspended it must be supported as mentioned above and isolated carefully to prevent sound transmission. Vibration isolators (purchased locally) must be placed under the unit.

- e. It is always recommended that an auxiliary drain pan be installed under a horizontal air handler (See Condensate Piping) to prevent possible damage to ceilings.
- f. Isolate the auxiliary drain pan from the unit or from the structure.
- g. Connect the auxiliary drain line to a separate drain line (no trap is needed in this line) and terminate according to National and Local codes.
- h. If a return duct is connected to the air handler, it must be the same dimensions as the return opening shown in the outline drawing.
- i. On units with sheetmetal returns: Return plenum should be flanged. Sheetmetal screws must be 1/2" in length or shorter.
- j. No sheetmetal screws may be used to attach return ductwork on the side of the unit.

- k. **Openings where field wiring enters the cabinet must be completely sealed.** Location of power entry is shown on the outline drawing. Use 2.5" clear stickers provided to seal all unused electrical knockouts. See Figure 11.

- l. After ductwork connections are made, seal airtight and per Local codes.

HORIZONTAL RIGHT

- a. **For maximum efficiency** and Customer ease of filter maintenance, it is recommended that a properly sized **remote filter** grille be installed for horizontal applications. Airflow should not exceed the face velocity of the filter being used. **The factory installed filter should then be removed from the unit.**
- b. Unit is shipped from the factory in the upflow or horizontal right configuration. Unit conversion is not required.
- c. If the unit is suspended, it must be supported from the bottom near both ends as well as the middle to prevent sagging. The service access must remain unobstructed. If the unit is supported along the length of the front and back with rails, the air handler only needs to be suspended at both ends. See Figure 10.

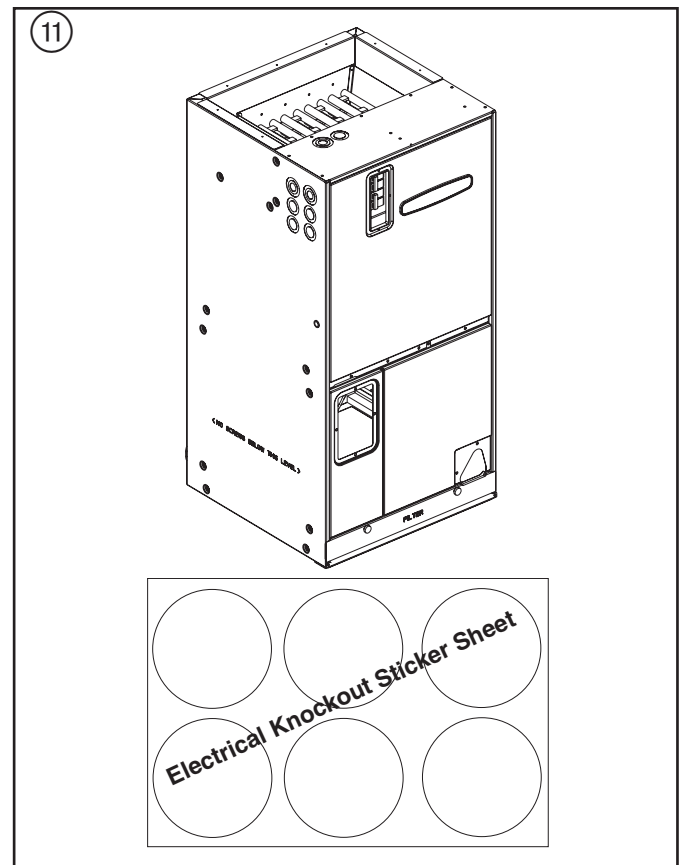

Installer's Guide

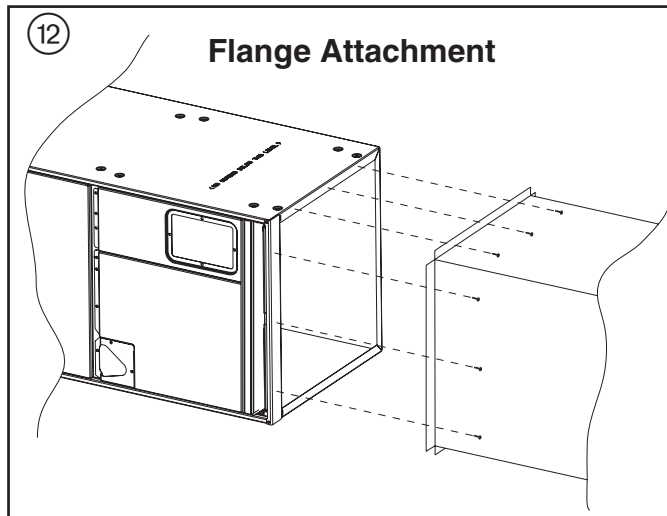

- d. If the unit is not suspended it must be isolated carefully to prevent sound transmission. Vibration isolators (purchased locally) must be placed under the unit.
- e. It is always recommended that an auxiliary drain pan be installed under a horizontal air handler (See Condensate Drain Piping) to prevent possible damage to ceilings.
- f. Isolate the auxiliary drain pan from the unit or from the structure.
- g. Connect the auxiliary drain line to a separate drain line (no trap is needed in this line) and terminate according to local codes.
- h. If a return duct is connected to the Air Handler, it must be the same dimensions as the return opening shown in the outline drawings.
 - i. On units with sheetmetal returns: Return plenum should be flanged. Sheetmetal screws must be 1/2" in length or shorter.
 - j. No sheetmetal screws may be used to attach return ductwork on the side of the unit.
- k. **Openings where field wiring enters the cabinet must be completely sealed.** Location of power entry is shown on the outline drawing. Use 2.5" clear stickers to seal all unused electrical knockouts and cage nut openings. See Figure 11.
- l. After ductwork connections are made, seal airtight and per local codes.

D. DUCT CONNECTIONS

The supply and return air ducts should be connected to the unit with flame retardant duct connectors.

Convertible duct flanges are provided on the discharge opening to provide a "flush fit" for 3/4" or 1-1/2" duct board applications. See the Outline drawing for sizes of the duct connections. After the duct is secured, seal around the supply duct to prevent air leakage.

NOTE: No sheetmetal screws may be used to attach return ductwork on the side.

NOTE: On units with sheetmetal returns: Return plenum should be flanged. Sheetmetal screws must be 1/2" in length or shorter. See Figure 12.

NOTE: If the convertible duct flanges are not used, they must be removed and discarded for proper airflow.

NOTE: Any duct board return connection can be made to the sides of the unit using tape or mastic.

E. REFRIGERANT PIPING

IMPORTANT:

Refrigerant piping must be routed to maintain service access to blower compartment and provide easy removal of filter access panel and filter.

1. Refrigerant connections are made outside the cabinet.

NOTE: TXV bulb MUST be protected (wrap a wet rag around the suction line between the TXV bulb and the braze joint) or removed, while brazing the tubing. Overheating of the sensing bulb will affect the functional characteristics and performance of the air handler.

NOTE: The area around refrigerant lines must be sealed and electrical inlets need to be sealed at both the low and the high voltage.

2. Installation of refrigerant lines is covered in the installation instructions packaged with the outdoor unit. Evacuation, leak testing and brazing procedures are included in those instructions. Read those instructions before starting installation of refrigerant lines.

NOTE: Torque specification for TXV equals 1/6 turn past finger tight.

F. BRAZING TO EVAPORATOR

NOTE: A brazing shield is provided in the information pack accompanying this unit. This shield fits over the refrigerant fittings while brazing. Wet the shield before brazing. See Figure 13.

IMPORTANT:

Do NOT unseal refrigerant tubing until ready to cut and fit refrigerant lines.

1. Remove the sealing caps from indoor coil field connections.
2. Field supplied tubing should be cut square, round and free of burrs at the connecting end. Clean the tubing to prevent contaminants from entering the system.

3. Run refrigerant tubing into the stub sockets of indoor unit coil. **Refrigerant line openings must be completely sealed.**
4. Braze and evacuate according to indoor and outdoor installation instructions.
5. Seal around refrigerant lines.

PAINTED AREAS OF UNIT MUST BE SHIELDED DURING BRAZING.

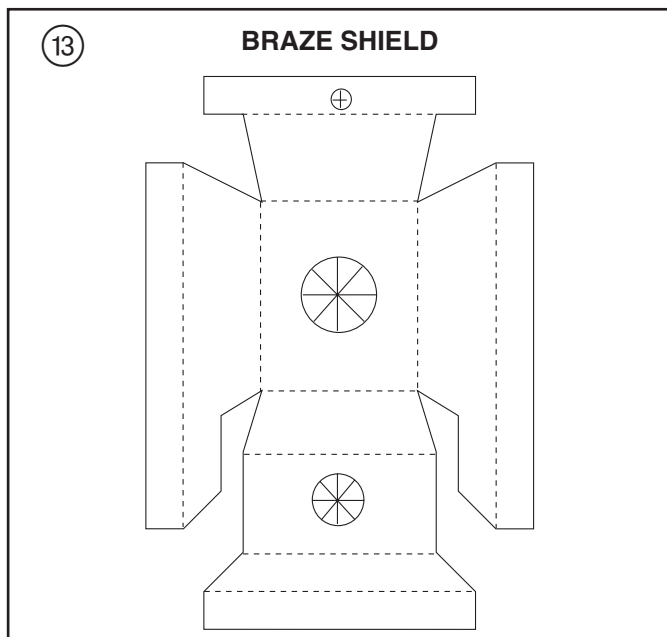

G. CONDENSATE DRAIN PIPING

NOTE: Make certain that the unit has been installed in a level position to ensure proper draining.

The indoor blower is downstream of the evaporator coil which creates a negative pressure at the condensate drain connections during operation. The condensate drain connections in front of the indoor coil are 3/4" NPT. The lower connection is the primary drain. See Figure 14.

Two secondary drain connections are provided for the different orientations (See Figure 14). The lower of the two should be connected as a backup to prevent condensate overflow by a blocked primary drain. The weep hole in center of drain coupling area should be sealed with caulk or RTV except in downflow unless secondary drain is connected.

For proper drainage of condensate, the following steps should be followed:

1. The primary drain line must be trapped with a minimum of 2" water seal as shown in Figures 15 & 16. **Do not use preformed 3/4" PVC running traps.**

The use of Field fabricated or manufactured traps as shown in Figures 15 & 16 is acceptable. The manufactured trap shown in Figure 15 allows for a float switch option to be added. Refer to the manufacturer's data and instructions for details.

2. The trap must be located within 4 feet of the air handler drain outlet connection.
3. It is recommended that a clean-out tee or cross be installed in the primary drain line for future maintenance (See Figures 15 & 16)

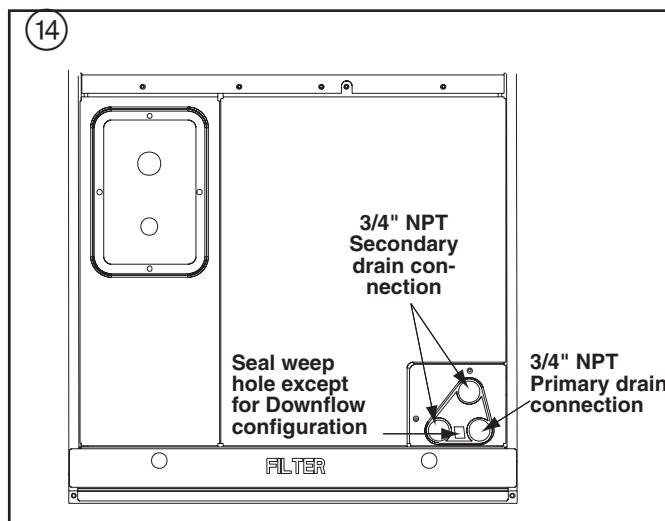

4. Do not use reducing fittings in the condensate drain lines.
5. Slope the drain lines downward a minimum of 1/4" per foot.
6. Insulate the primary drain to prevent sweating where dew point temperatures may be met.
7. **Provide means for drainage to prevent winter freeze-up of condensate line.**
8. Do not connect the drain line to a closed drain system.
9. Use Teflon® tape on the air handler drain line connections! **Do Not** Use pipe joint compound or PVC/CPVC cement!

It is always recommended that an auxiliary drain pan be installed under a horizontally installed air handler. Connect the auxiliary drain line to a separate drain line (no trap is needed in this line) and terminate according to local codes.

NOTE: DO NOT use a torch or flame near the plastic drain pan coupling.

NOTE: DO NOT tighten the drain pipe excessively. Support the condensate piping and traps outside the unit to prevent strain on the drain coupling.

Installer's Guide

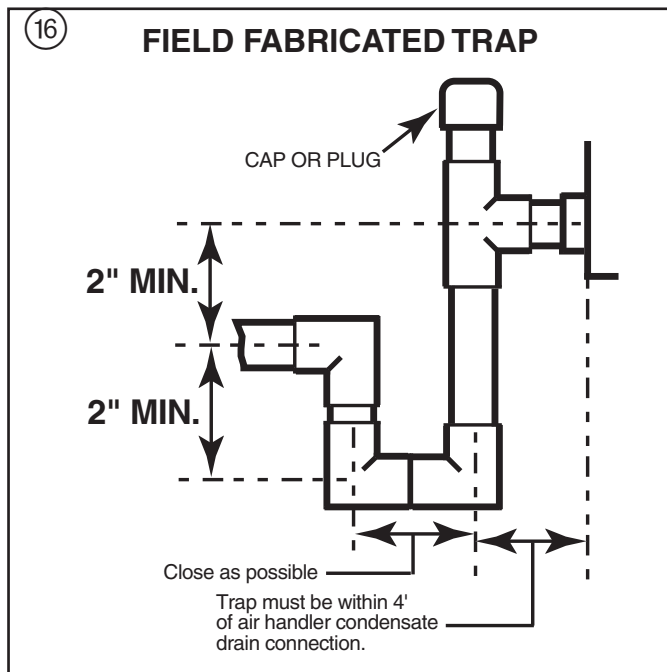
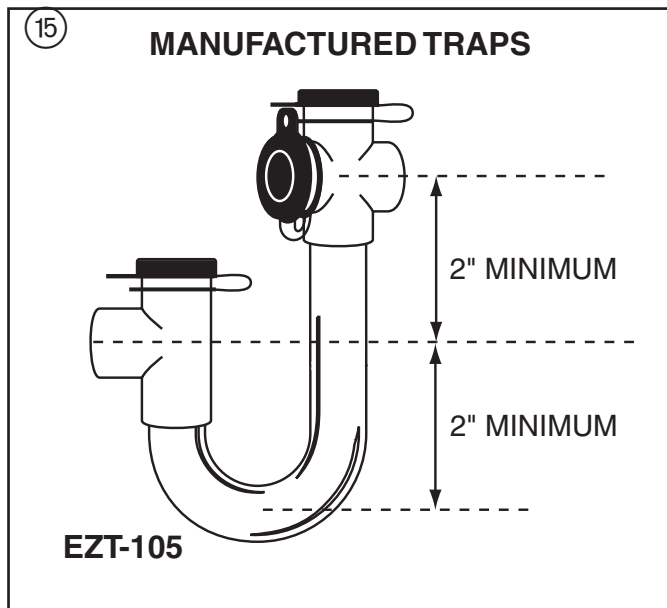

⚠ WARNING

ELECTRICAL SHOCK HAZARD
LOCK OUT UNIT DISCONNECT SWITCH IN OPEN POSITION BEFORE SERVICING UNIT. FAILURE TO FOLLOW THIS WARNING COULD RESULT IN PROPERTY DAMAGE, PERSONAL INJURY, OR DEATH.

H. ELECTRICAL — POWER WIRING

1. These Air Handlers are shipped from the factory wired for 230 volts. The units may be wired for 208 volts. Follow instructions on unit wiring diagram located on blower housing and in the Service Facts document included with the unit.

2. The selection of wire and fuse sizes should be made according to the Minimum Branch Circuit Ampacity and the Maximum Overcurrent Device listed on the unit nameplate.
3. Field wiring diagrams for electric heaters and unit accessories are shipped with the accessory.
4. Wiring must conform to National and Local codes. Ground unit per Local codes with good safety procedures.
If an electric heater is not installed, the Knockout Plate provided in the Accessory Kit **MUST** be installed on the air handler and the conduit terminated to it. The electrical connections are made using the two power leads and ground wire connections which are located near the discharge of the blower. **Openings where field wiring enters the cabinet must be completely sealed.** Location of power entry is shown on the outline drawing. Use 2.5" clear stickers to seal all unused electrical knockouts.

NOTE: If air handler is used with or without a heater, the 7/8" electrical entry hole as well as any other cabinet penetrations must be sealed air tight.

I. CONTROL WIRING

1. Connect wiring between indoor unit, outdoor unit and Comfort Control. The use of color-coded low-voltage wires is recommended.
2. A low voltage terminal board is provided for control wiring, and is located on the left side of the cross brace in the center of the unit.
3. Field wiring diagrams are provided which show the low voltage wiring hook-up for a single speed cooling only system (with supplementary heaters) and a heat pump system (with supplementary heaters). Plug in type electrical connectors are provided for use with supplementary heaters.

IMPORTANT:

When supplementary heaters are installed, inspect to insure that all packaging material has been removed.

NOTE: Direct drive motors have bearings which are permanently lubricated and under normal use lubrication is not recommended.

4TEC AIR HANDLER WITH HEAT PUMP WITH SUPPLEMENTAL HEAT

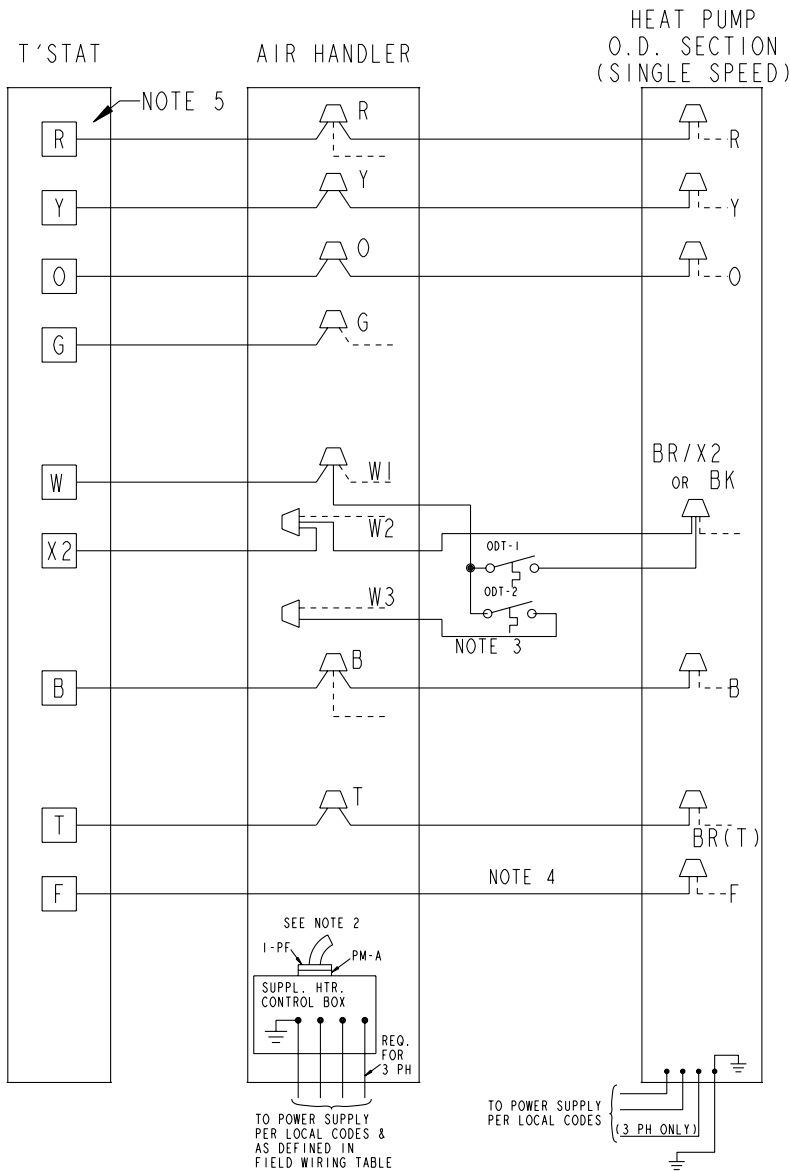

NOTES:

1. LOW VOLTAGE WIRING TO BE NO. 18 A.W.G. MINIMUM CONDUCTORS.
2. WHEN FIELD-INSTALLED HEATERS ARE USED, DISCARD POWER LEADS WITH POLARIZED PLUG I-PM AND CONNECT I-PF TO MATING PLUG IN THE HEATER CONTROL BOX AS SHOWN.
3. IF OUTDOOR THERMOSTAT (ODT) IS NOT USED, CONNECT W1 TO W2 TO W3.
4. CONNECT IN THIS MANNER IF O.D. UNIT HAS "F" CONNECTION.
5. SEE HEATER WIRING DIAGRAM FOR HEATING ANTICIPATOR SETTINGS.

From Dwg. B801082 Rev. 2

Installer's Guide

4TEC AIR HANDLERS WITH SINGLE SPEED COOLING UNIT, 1 STAGE HEAT

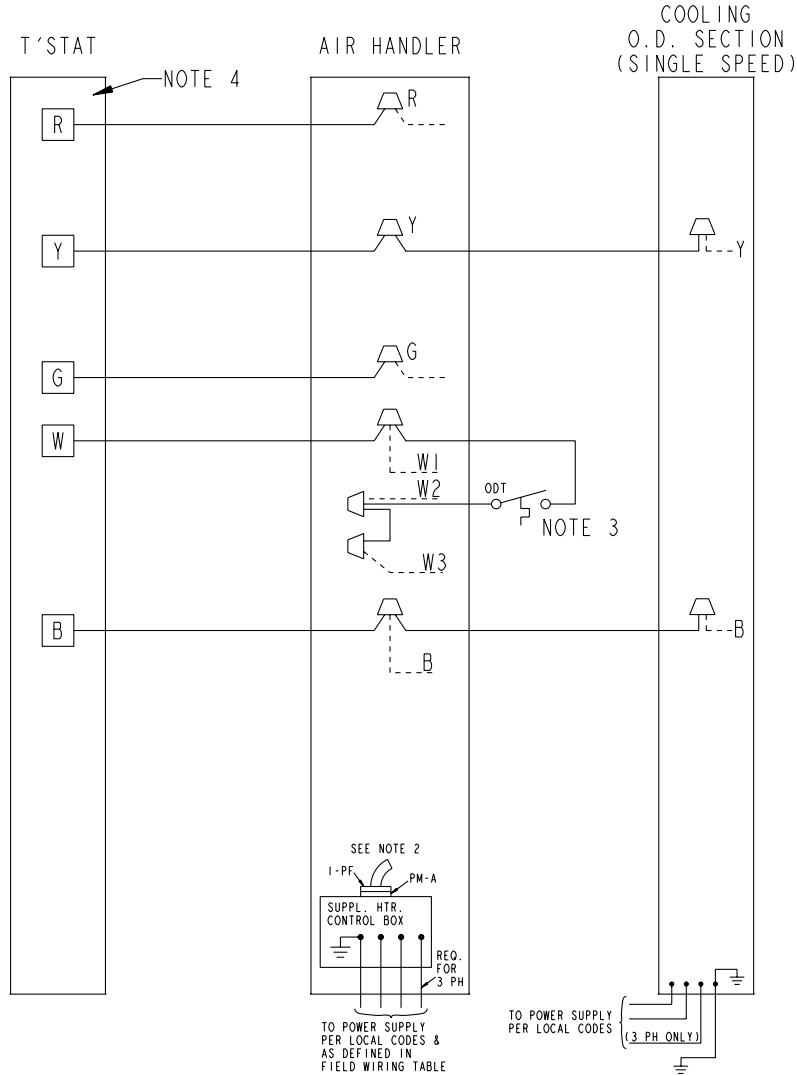

NOTES:

1. LOW VOLTAGE WIRING TO BE NO. 18 A.W.G. MINIMUM CONDUCTOR.
2. WHEN FIELD-INSTALLED HEATERS ARE USED, DISCARD POWER LEADS WITH POLARIZED PLUG PM-A AND CONNECT 1-PF TO MATING PLUG IN THE HEATER CONTROL BOX AS SHOWN.
3. IF OUTDOOR THERMOSTAT (ODT) IS NOT USED, CONNECT W1 TO W2 TO W3.
4. SEE HEATER WIRING DIAGRAM FOR HEATING ANTICIPATOR SETTING.

From Dwg. B801083 Rev. 2

4TEC AIR HANDLER WITH SINGLE SPEED COOLING UNIT, 2 STAGE HEAT

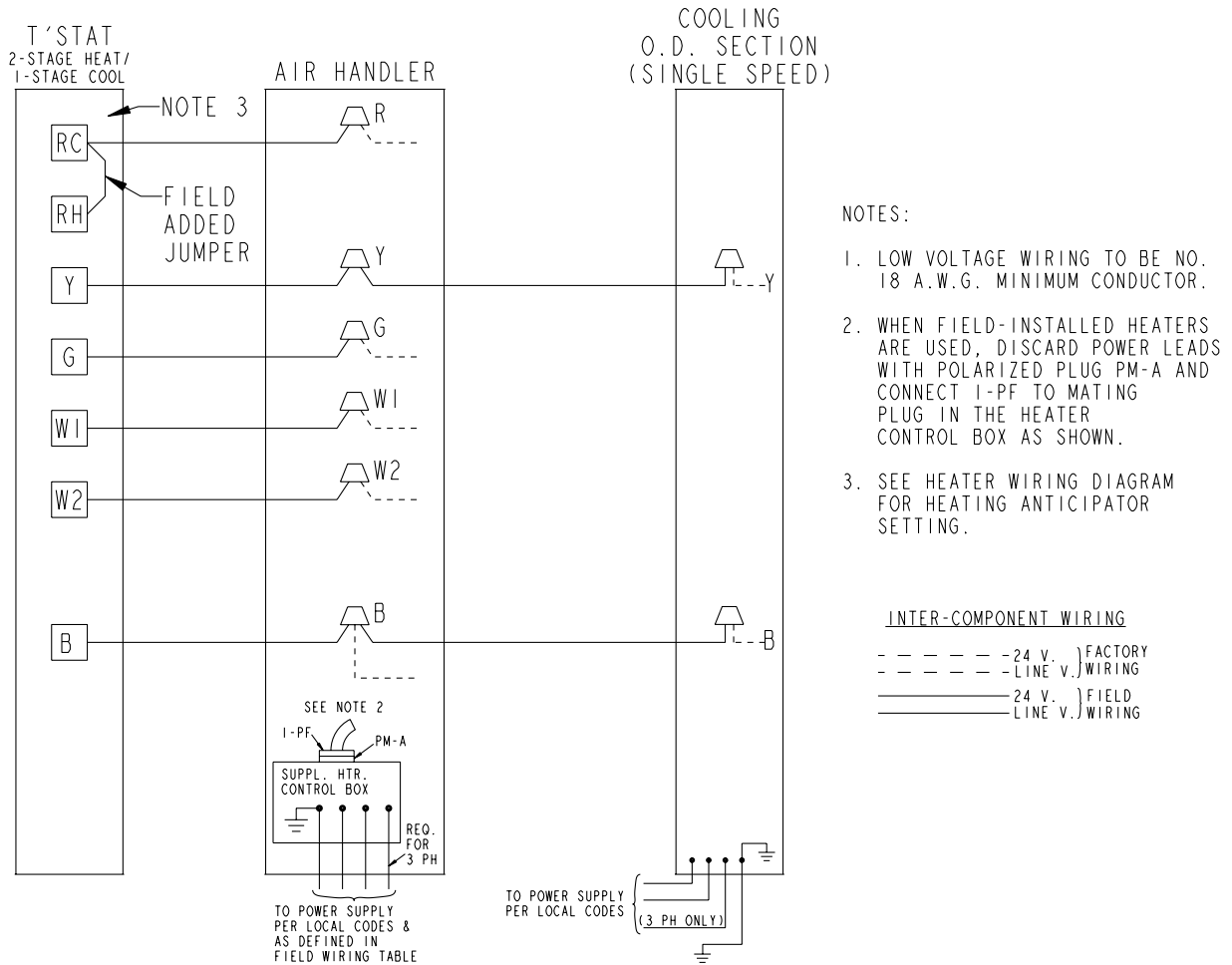

From Dwg. B801081 Rev. 2

OUTLINE DRAWING FOR 4TEC3F24-60B

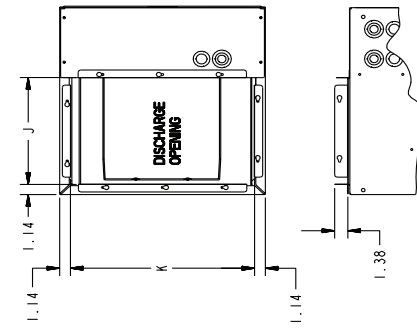
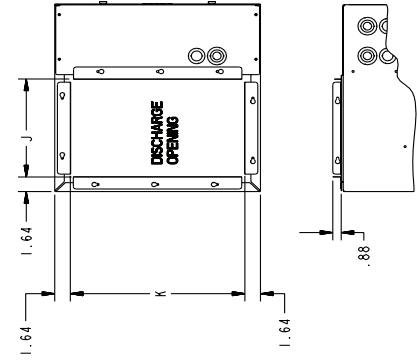

MODEL NO.	FIG. 1		FIG. 2	
	J	K	J	K
2TEEC3F31A, 4TEEC3F31B 2TEEC3F18B, 24B, 30B, 36B 4TEEC3F18B, 24B, 30B, 36B TWE030CA	19.22	18.22	19.22	18.22
2TEEC3F37A, 4TEEC3F37B 2TEEC3F42B, 48B, 60B 4TEEC3F42B, 48B, 60B TWE040CA, 50CA	12.02	21.22	11.02	20.22
2TEEC3F40A, 49A, 65A 4TEEC3F40B, 49B, 65B 2TEEC3F55B 4TEEC3F55B	23.72	22.72	23.72	22.72

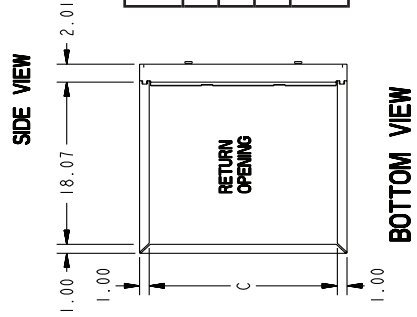
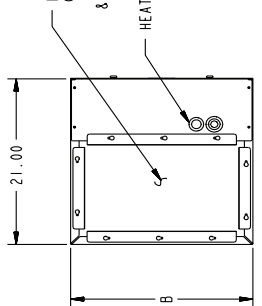
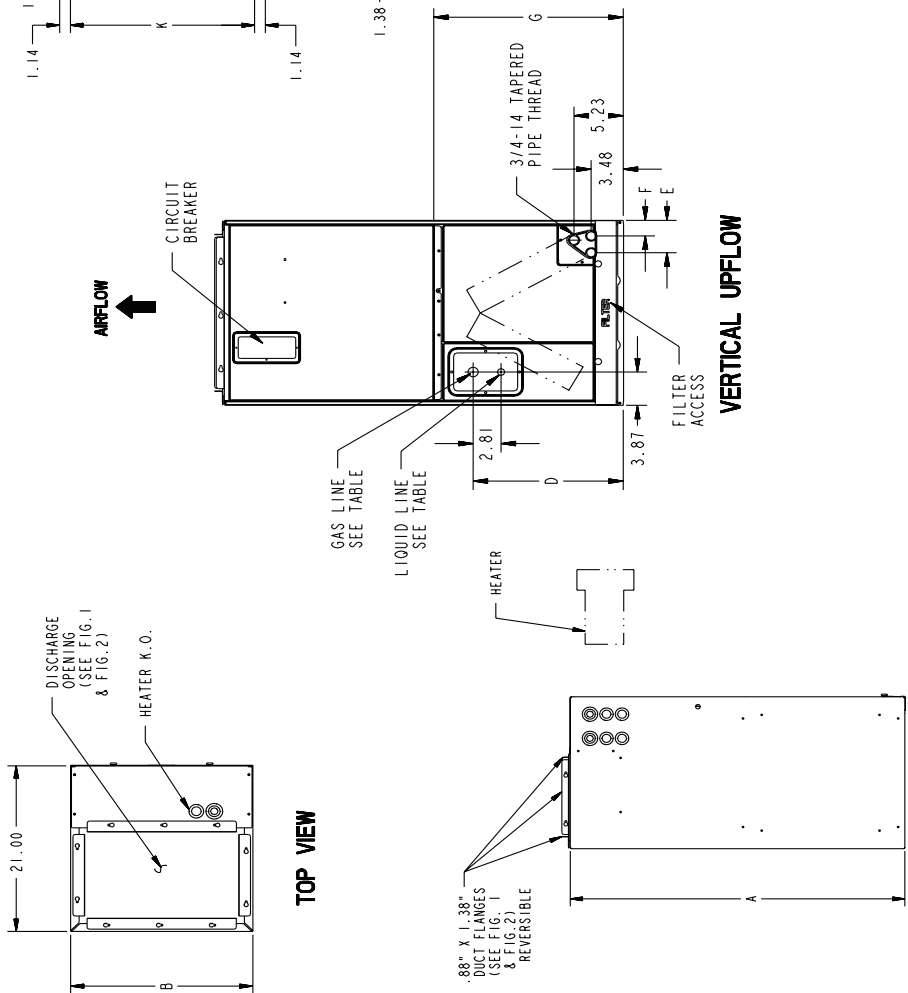

MINIMUM UNIT CLEARANCE TABLE	TO	
	COMBUSTIBLE MATERIAL (REQUIRED)	SERVICE CLEARANCE (RECOMMENDED)
SIDES	0"	2"*
FRONT	0"	21"
BACK	0"	0"
INLET DUCT	0"	1"
OUTLET DUCT	1"*	

* 1" FOR THE FIRST 3 FT. OF OUTLET DUCT WHEN ELECTRIC HEATERS ARE INSTALLED EXCEPT MODELS BAYH1405, 1408, AND 1410 ARE APPROVED FOR 0" PLENUM AND DUCT CLEARANCE IN THE UPFLOW CONFIGURATION ONLY ON TWE-P MODELS.

MODEL NO.	A	B	C	D	E	F	G	FLOW CONTROL	GAS LINE BRAZE	LIQ LINE BRAZE
4TEC3F24B	43	21.50	19.50	15.66	3.62	1.89	N/A	TXV/NB	5/8	5/16
4TEC3F36B	45	21.50	19.50	17.66	3.62	1.89	N/A	TXV/NB	3/4	3/8
4TEC3F42B	51.75	23.50	21.50	22.41	3.62	1.89	N/A	TXV/NB	3/4	3/8
4TEC3F48B	57.90	23.50	21.50	27.57	3.62	1.89	32.39	TXV/NB	7/8	3/8

4TEC AIR HANDLER DIMENSIONAL DATA

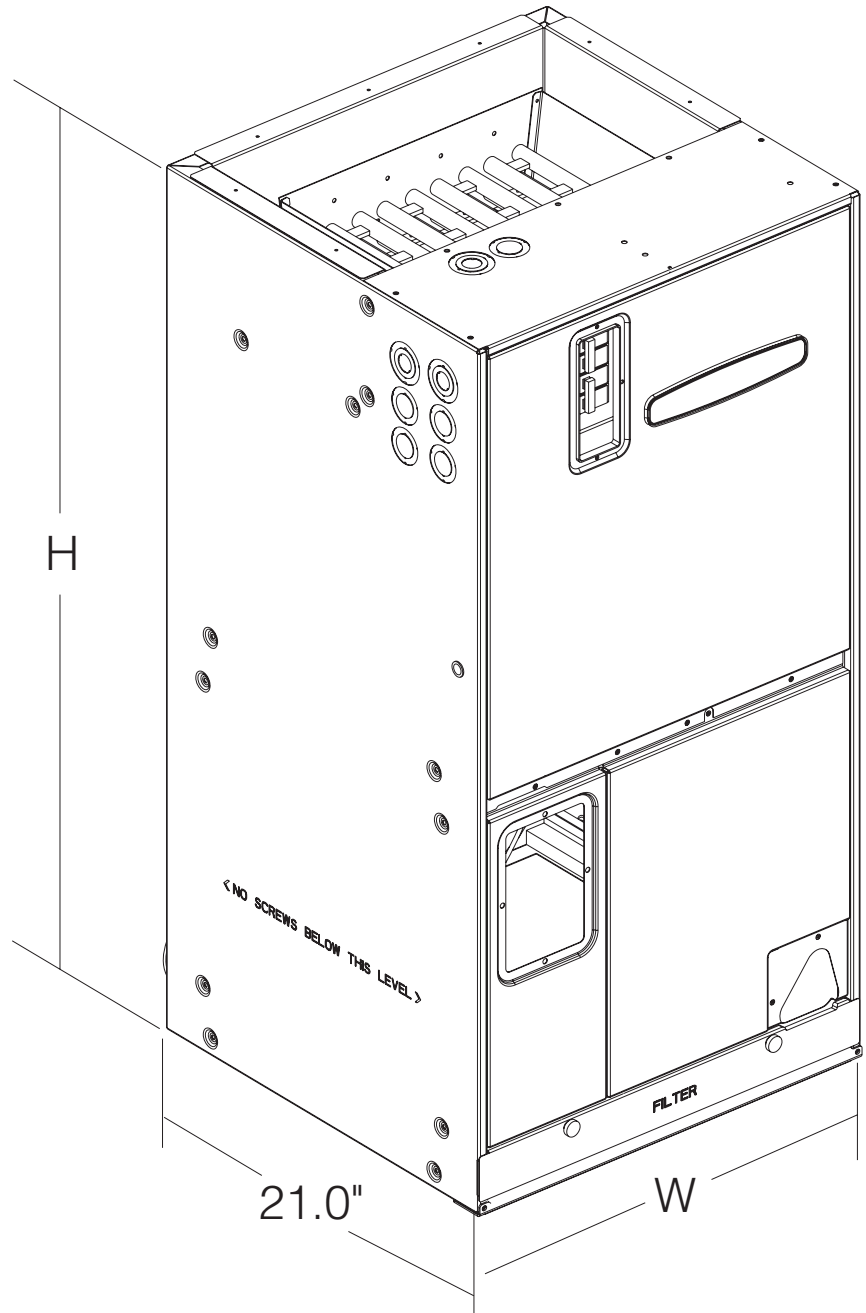

4TEC3F48B & 60B
are two piece cabinets

MODEL	H	W
4TEC3F24B	43.00	21.50
4TEC3F36B	45.00	21.50
4TEC3F42C	51.75	23.50
4TEC3F48B	57.90	23.50
4TEC3F60B	57.90	23.50

Installer's Guide

J.CHECKOUT PROCEDURE

1. Check the Air Handler operation and installation in accordance with these instructions below.
2. "Operational Procedure" for the system installation can be found in the outdoor unit installer guide and will be compatible with this Air Handler.

⚠ CAUTION

Cardboard packing material must be removed from inside the blower assembly before starting the unit. Failure to do so may cause indoor blower motor failure.

⚠ WARNING

**ELECTRICAL SHOCK WARNING
LOCK OUT UNIT DISCONNECT SWITCH IN OPEN POSITION BEFORE SERVICING UNIT. FAILURE TO FOLLOW THIS WARNING COULD RESULT IN PROPERTY DAMAGE, PERSONAL INJURY, OR DEATH.**

The following warning complies with State of California law, Proposition 65.

⚠ WARNING: This product contains fiberglass wool insulation! Fiberglass dust and ceramic fibers are believed by the State of California to cause cancer through inhalation. Glasswool fibers may also cause respiratory, skin, or eye irritation.

PRECAUTIONARY MEASURES

- Avoid breathing fiberglass dust.
- Use a NIOSH approved dust/mist respirator.
- Avoid contact with the skin or eyes. Wear long-sleeved, loose-fitting clothing, gloves, and eye protection.
- Wash clothes separately from other clothing: rinse washer thoroughly.
- Operations such as sawing, blowing, tear-out, and spraying may generate fiber concentrations requiring additional respiratory protection. Use the appropriate NIOSH approved respirator in these situations.

FIRST AID MEASURES

Eye Contact - Flush eyes with water to remove dust. If symptoms persist, seek medical attention.

Skin Contact - Wash affected areas gently with soap and warm water after handling.

CHECKOUT PROCEDURES

After installation has been completed, it is recommended that the Air Handler be checked against the following checklist.

- | | |
|---|---|
| 1. Make sure power is "OFF" at power disconnect switch..... [] | 6. Make sure secondary drain pan is installed [] |
| 2. Check all field wiring for tight connections. See that grounding of unit is in accord with code [] | 7. Check power supply for correct requirements per unit nameplate [] |
| 3. Make sure unit suspension (if used) is secure and that there are no tools or loose debris in, around or on top of the unit [] | 8. Check filters for proper size. Inform owner of proper procedure for removal and reinstallation [] |
| 4. Check all duct outlets; they must be open and unrestricted [] | 9. Energize the system and carefully observe its operation; make any necessary adjustment..... [] |
| 5. Check drain lines and be sure all joints are tight [] | 10. Instruct owner, engineer (if possible) on proper operating procedure and leave Use and Care Manual with owner [] |

SUPPLEMENTARY HEATERS CHECKOUT PROCEDURES, IF USED DOES HEATER REQUIRE A SPECIAL CIRCUIT? SEE "LIMITATIONS AND RECOMMENDATIONS"

1. Be sure the disconnect switch is "OFF", and safety label (if any) is attached..... []
2. Check on field wiring for tight connections and grounding according to codes []
3. Check circuit protection for proper size per nameplate specifications []
4. Check control box panel — in place and secured..... []

NOTE: OPERATION OF HEATERS MUST BE CHECKED DURING THE OPERATION CHECK OF THE TOTAL SYSTEM.

Trane
6200 Troup Highway
Tyler, TX 75707
www.trane.com

For more information contact your local dealer (distributor)

The manufacturer has a policy of continuous product and product data improvement, and it reserves the right to change design and specifications without notice.