

1-1/2 – 3 Ton Air Handlers

Upflow / Horizontal Left

2/4TGB3F18A 2/4TGB3F25A

2/4TGB3F30A 2/4TGB3F36A

⚠ WARNING: HAZARDOUS VOLTAGE - DISCONNECT POWER BEFORE SERVICING

ALL phases of this installation must comply with NATIONAL, STATE AND LOCAL CODES

IMPORTANT—This Document is customer property and is to remain with this unit. Please return to service information pack upon completion of work.

A. GENERAL INFORMATION

⚠ WARNING

THIS INFORMATION IS FOR USE BY INDIVIDUALS HAVING ADEQUATE BACKGROUNDS OF ELECTRICAL AND MECHANICAL EXPERIENCE. ANY ATTEMPT TO REPAIR A CENTRAL AIR CONDITIONING PRODUCT MAY RESULT IN PERSONAL INJURY AND/OR PROPERTY DAMAGE. THE MANUFACTURER OR SELLER CANNOT BE RESPONSIBLE FOR THE INTERPRETATION OF THIS INFORMATION, NOR CAN IT ASSUME ANY LIABILITY IN CONNECTION WITH ITS USE.

⚠ CAUTION

To prevent shortening its service life, the air handler should not be used during the finishing phases of construction. The low return air temperatures can lead to the formation of condensate. Condensate in the presence of chlorides and fluorides from paint, varnish, stains, adhesives, cleaning compounds, and cement creates a corrosive condition which may cause rapid deterioration of the cabinet and internal components.

These instructions do not cover all variations in systems or provide for every possible contingency. Should further information be desired or particular problems arise which are not covered sufficiently by this manual, contact your local distributor or the manufacturer as listed on the air handler nameplate.

These Air Handlers are vertical upflow and horizontal left configuration only. Refer to Section B beginning on page 2 for additional information.

INSPECTION

Check carefully for any shipping damage. This must be reported to and claims made against the transportation company immediately. Check to be sure all major components are in the unit. Any missing parts should be reported to your supplier at once, and replaced with authorized parts only.

Contents

General Information	1
Installation Limitations & Recommendations	1
Unit Installation	2
Vertical Upflow	2
Horizontal Left	2
Refrigerant Piping	3
Condensate Drain Piping	3
Electrical - Wiring	4
Hook Up Diagrams	5
Outline Drawings	7
Checkout Procedures	8

INSTALLATION LIMITATIONS & RECOMMENDATIONS

The general location of the air handler is normally selected by the architect, contractor and/or home owner for the most effective application and satisfaction.

These air handlers are suitable for installation in a closet, alcove or utility room with free, non-ducted, air return, using the area space as a return air plenum. With ducted supply air, if the minimum clearances to combustible materials and service access are observed, the above installations are suitable.

NOTE: Condensation may occur on the surface of the air handler when installed in an unconditioned location. When units are installed in unconditioned spaces, verify that all electrical and refrigerant line penetrations on the air handler are sealed completely.

This area may also be used for other purposes, including an electric hot water heater - **but in no case shall a fossil fuel device be installed and/or operated in the same closet, alcove or utility room.**

Installer's Guide

In addition, these air handlers are suitable for installation in an attic, garage or crawl space with ducted supply and return air.

This equipment (for models **2/4TGB3F18, 25, 30, 36A only**) has been evaluated in accordance with the Code of Federal Regulations, Chapter XX, Part 3280 or the equivalent. "SUITABLE FOR MOBILE HOME USE"

For proper installation the following items must be considered:

1. If adequate power is available and correct according to nameplate specifications.
2. Pursuant to Florida Building Code 13-610.2.A.2.1, this unit meets the criteria for a factory sealed air handler.
2. Insulate all ducts, particularly if unit is located outside of the conditioned space.
3. To ensure maximum efficiency and system performance, the existing supply and return duct system static pressures must not exceed the total available static pressure of the air handler. Reference ACCA Manual D, Manual S and Manual RS along with the air handler Product Data and Service Facts for additional information.
4. It is recommended that the outline drawing be studied and dimensions properly noted and checked against selected installation site. By noting in advance which knockouts are to be used, proper clearance allowances can be made for installation and possible future service.
5. The Refrigerant lines must be sealed and Electrical inlets need to be sealed at both the low and the high voltage.
6. If supplementary heat is to be added, power supply must be sufficient to carry the load. In addition, minimum air flow settings, unit and duct clearances to combustible material must be maintained as stated on the air handler rating nameplate.

CAUTION

For air handlers not equipped with a factory installed electric heater, a field installed heater is available from the manufacturer. Only manufacturer-built heaters are approved for use in the air handler. These heaters have been designed and tested in accordance with UL standards to provide safe and reliable operation. A list of approved heaters is provided on the air handler rating nameplate. Heaters that are not factory approved could cause damage and are not covered under equipment warranty.

7. If field installed electric heaters are applied, minimum air flow settings, unit and duct clearances to combustibles must be maintained as stated on the air handler rating nameplate.
8. If the unit is installed without a return air duct, applicable local codes may limit this air handler to installation only in a single story residence & within conditioned space.
9. If the outdoor unit is to be installed later, or by others, then installation of the air handler must be made to allow access for refrigerant lines, or attach refrigerant lines to air handler when installing.

10. Make sure there are provisions for installing condensate drain lines.
11. Route refrigerant & condensate drain lines away from air handler so they do not interfere with access panels and filters.
12. When external accessories are used, the additional height and width requirements must be considered in the overall space needed.
13. These units are not approved for outdoor installation.
14. These units are approved for draw-through application only.

B. UNIT INSTALLATION

UPFLOW

- a. **For maximum efficiency**, the horizontal drip tray should be removed. Tray removal requires that the coil be removed by sliding the coil out on the coil channel supports. The tray is detached by removing the two screws at the drain pan and the two screws holding the two brackets at the top of the coil.
- b. **Openings where field wiring enters the cabinet must be completely sealed.** The Refrigerant lines must be sealed and Electrical inlets need to be sealed both low and high voltage. Location of power entry is shown on the Outline Drawing.
- c. Position unit on Pedestal or other suitable foundation. If Pedestal is not used, a frame strong enough to support the total weight must be provided. Provide a minimum height of 14 inches for proper unrestricted airflow.
- d. If a return air duct is connected to the air handler, it must be the same dimensions as shown in the outline drawing.
- e. Pedestal and unit should be isolated from the foundation using a suitable isolating material.

HORIZONTAL LEFT

- a. **For maximum efficiency** and Customer ease of filter maintenance, it is recommended that a properly sized **remote filter** and grille be installed for horizontal applications. Airflow should not exceed the face velocity of the filter being used. **The factory installed filter should then be removed from the unit.**
- b. The unit is shipped from the factory in the horizontal left airflow position.
- c. **Openings where field wiring enters the cabinet must be completely sealed.** The Refrigerant lines must be sealed and Electrical inlets need to be sealed both low and high voltage. Location of power entry is shown on the Outline Drawing.
- d. The unit may be suspended as long as the unit is supported from both ends as well as the middle to prevent sagging and service access is not obstructed.
- e. If the unit is not suspended it must be isolated carefully to prevent sound transmission. Vibration isolators (purchased locally) must be placed under the unit.

- f. It is always recommended that an auxiliary drain pan be installed under a horizontal air handler (See Condensate Drain Piping) to prevent possible damage to ceilings.
- g. Isolate the auxiliary drain pan from the unit or from the structure.
- h. Connect the auxiliary drain line to a separate drain line (no trap is needed in this line) and terminate according to local codes.
- i. If a return duct is connected to the Air Handler, it must be the same dimensions as the return opening shown in the outline drawings.

C. DUCT CONNECTIONS

The supply and return air ducts should be connected to the unit with flame retardant duct connectors.

Convertible duct flanges are provided to make a "flush fit" for 3/4" or 1-1/2" ductboard applications. Three are located in the accessory kit shipped with the unit and one is installed on the discharge opening. If the duct flanges are not needed, the installed flange must be removed. See the Outline drawing for sizes of the discharge opening. After ductwork is secured, seal the ductwork per local and national codes to prevent air loss/infiltration.

D. REFRIGERANT PIPING

IMPORTANT:

Refrigerant piping must be routed to maintain service access to blower compartment and provide easy removal of filter access panel and filter.

1. Refrigerant connections are made outside the cabinet.

NOTE:

TXV bulb MUST be protected (wrap a wet rag around the suction line between the TXV bulb and the braze joint) or removed, while brazing the tubing. Overheating of the sensing bulb will affect the functional characteristics and performance of the air handler.

2. If changing the Thermostatic valve (TEV/TXV), be sure to use a wrench and backup wrench to **tighten the mechanical fittings 1/6 turn past finger tight** upon installation.
3. Installation of refrigerant lines is covered in the installation instructions packaged with the outdoor unit. Evacuation, leak testing and brazing procedures are included in those instructions. Read those instructions before starting installation of refrigerant lines.

NOTE:

TXV Equipped is Non-Bleed, and may require a start kit on the outdoor unit.

NOTE:

Refrigerant line openings must be sealed along with field wiring.

E. BRAZING TO EVAPORATOR SECTION

IMPORTANT:

Do **NOT** unseal refrigerant tubing until ready to cut and fit refrigerant lines.

1. Remove the sealing caps from indoor coil field connections.
2. Field supplied tubing should be cut squared-off, ensuring the tube is still round and free of burrs at the connecting end. Clean the tubing to prevent contaminants from entering the system.
3. Run refrigerant tubing into the stub sockets of indoor unit coil. **Refrigerant line openings must be completely sealed.**
4. Braze and evacuate according to indoor and outdoor installation instructions.

IMPORTANT:

Painted areas of unit must be shielded during brazing.

F. CONDENSATE DRAIN PIPING

NOTE:

Make certain that the unit has been installed in a level position to ensure proper draining.

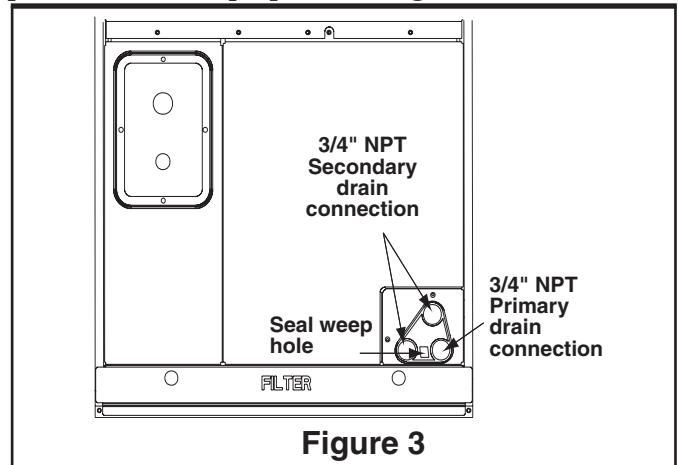

The indoor blower is downstream of the evaporator coil which creates a negative pressure at the condensate drain connections during operation. The condensate drain connections in front of the indoor coil are 3/4" NPT. The lower connection is the primary drain. See Figure 3.

Two secondary drain connections are provided for the different orientations (See Figure 3). The lower of the two should be connected as a backup to prevent condensate overflow by a blocked primary drain. The weep hole in center of drain coupling area should be sealed with caulk or RTV.

For proper drainage of condensate, the following steps should be followed:

1. The primary drain line must be trapped with a minimum of 2" water seal as shown in Figures 4 & 5.
2. **Do not use preformed 3/4" PVC running traps.** The use of Field fabricated or manufactured traps as shown in Figures 4 & 5 is acceptable. The manufactured trap shown in Figure 4 allows for a float switch option to be added. Refer to the manufacturers data and instructions for details.
3. **The trap must be located within 4 feet of the air handler drain outlet connection.**
4. It is recommended that a clean-out tee or cross be installed in the primary drain line for future maintenance (See Figures 4 & 5).

Installer's Guide

5. Do not use reducing fittings in the condensate drain lines.
6. Slope the drain lines downward a minimum of 1/4" per foot.
7. Insulate the primary drain to prevent sweating.
8. **Provide means for drainage to prevent winter freeze-up of condensate line.**
9. Do not connect the drain line to a closed drain system.
10. Use Teflon® tape on the air handler drain line connections! **Do Not** Use pipe joint compound or PVC/CPVC cement!

It is always recommended that an auxiliary drain pan be installed under a horizontally installed air handler. Connect the auxiliary drain line to a separate drain line (no trap is needed in this line) and terminate according to local codes.

NOTE:

DO NOT use a torch or flame near the plastic drain pan coupling.

NOTE:

DO NOT tighten the drain pipe excessively. Support the condensate piping and traps outside the unit to prevent strain on the drain coupling.

G. ELECTRICAL — POWER WIRING

1. These Air Handlers are shipped from the factory wired for 230 volts. The units may be wired for 208 volts. Follow instructions on unit wiring diagram located on blower housing and in the Service Facts document included with the unit.
2. The selection of wire and fuse sizes should be made according to the Minimum Branch Circuit Ampacity and the Maximum Overcurrent Device listed on the unit nameplate.
3. Field wiring diagrams for electric heaters and unit accessories are shipped with the accessory.
4. Wiring must conform to National and Local codes. Ground unit per Local codes with good safety procedures.

If an electric heater is not installed, the Knockout Plate provided in the Accessory Kit **MUST** be installed on the air handler and the conduit terminated to it. The electrical connections are made using the two power leads and ground wire connections which are located near the discharge of the blower.

⚠ WARNING

TO PREVENT INJURY OR DEATH DUE TO ELECTRICAL SHOCK OR CONTACT WITH MOVING PARTS, LOCK UNIT DISCONNECT SWITCH IN OPEN POSITION BEFORE SERVICING UNIT.

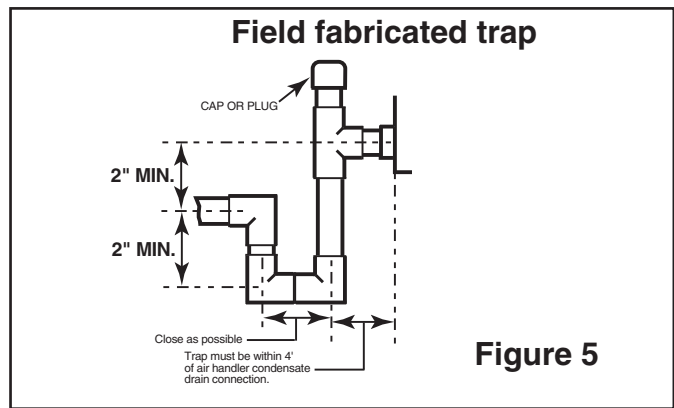
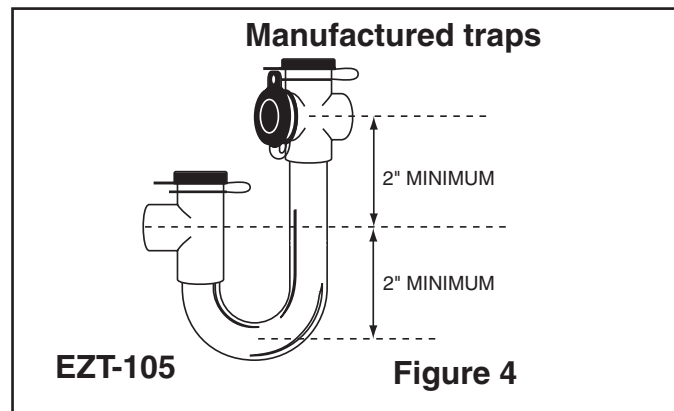

NOTE:

If air handler is used *with or without* a heater, the 7/8" electrical entry hole as well as any other cabinet penetrations *must be sealed air tight.*

H. CONTROL WIRING

1. Connect wiring between indoor unit, outdoor unit and thermostat. The use of color-coded low-voltage wires is recommended.
2. Field wiring diagrams are provided which show the low voltage wiring hookup for a single speed cooling only system (with supplementary heaters) and a heat pump system (with supplementary heaters). Plug in type electrical connectors are provided for use with supplementary heaters.

IMPORTANT:

When supplementary heaters are installed, inspect to insure that all packaging material has been removed.

NOTE:

Direct drive motors have bearings which are permanently lubricated and under normal use lubrication is not recommended.

2/4TGB AIR HANDLERS WITH SINGLE STAGE COOLING, 1 STAGE HEAT

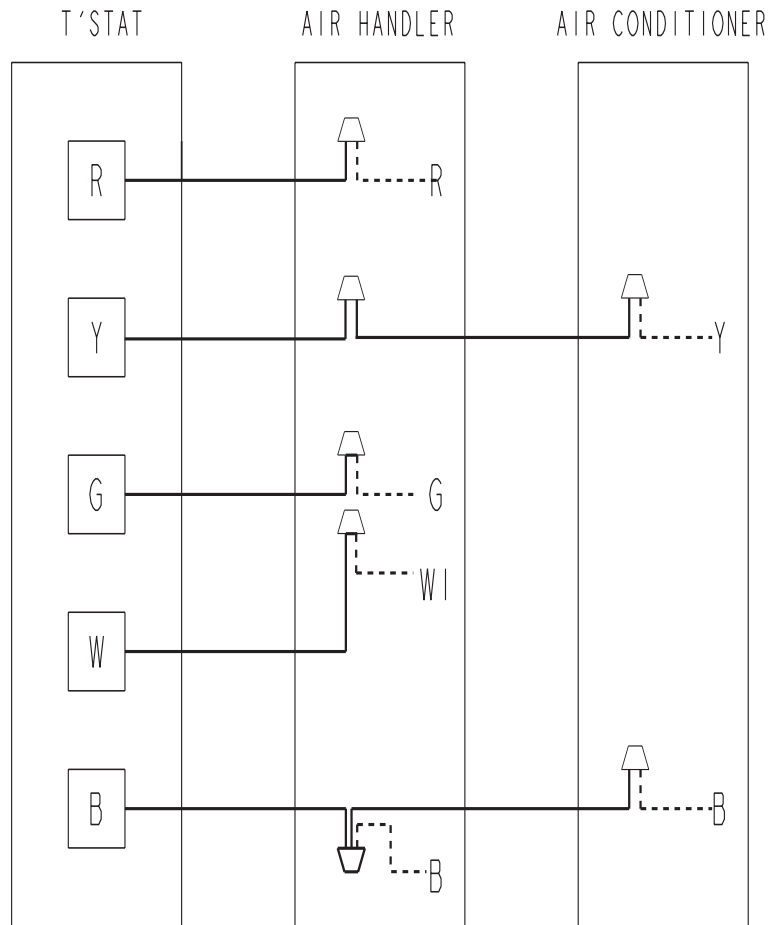

1. BE SURE POWER SUPPLY AGREES WITH EQUIPMENT NAMEPLATE.
2. POWER WIRING AND GROUNDING OF EQUIPMENT MUST COMPLY WITH LOCAL CODES.
3. LOW VOLTAGE WIRING TO BE NO. 18 AWG MINIMUM CONDUCTOR.

24V INTER-COMPONENT WIRING

----- (FACTORY) _____ (FIELD)
(WIRING) (WIRING)

PRINTED FROM B800978P01

Installer's Guide

2/4TGB AIR HANDLERS WITH SINGLE SPEED HEAT PUMP

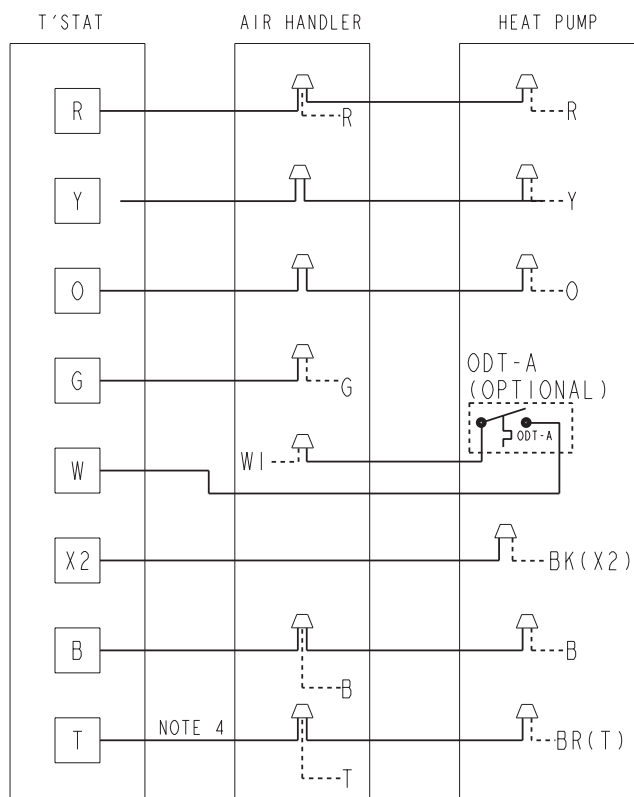

NOTES:

1. BE SURE POWER SUPPLY AGREES WITH EQUIPMENT NAMEPLATE.
2. POWER WIRING AND GROUNDING OF EQUIPMENT MUST COMPLY WITH LOCAL CODES.
3. LOW VOLTAGE WIRING TO BE NO. 18 AWG MINIMUM CONDUCTOR.
4. N/A TO PROGRAMMABLE THERMOSTAT.

24V INTER-COMPONENT WIRING

----- (FACTORY) (FIELD)
 (WIRING) (WIRING)

PRINTED FROM B800980P01

2/4TGB AIR HANDLERS WITH SINGLE STAGE COOLING AND TWO STAGE HEATING

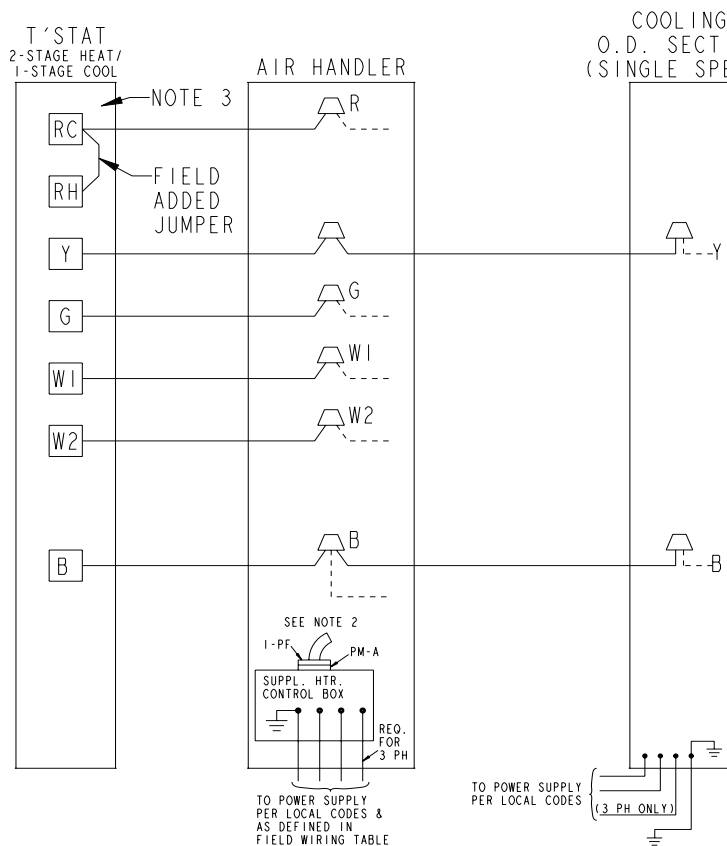

NOTES:

1. LOW VOLTAGE WIRING TO BE NO. 18 A.W.G. MINIMUM CONDUCTOR.
2. WHEN FIELD-INSTALLED HEATERS ARE USED, DISCARD POWER LEADS WITH POLARIZED PLUG PM-A AND CONNECT 1-PF TO MATING PLUG IN THE HEATER CONTROL BOX AS SHOWN.
3. SEE HEATER WIRING DIAGRAM FOR HEATING ANTICIPATOR SETTING.

INTER-COMPONENT WIRING

----- -24 V. } FACTORY
 - - - - - LINE V. } WIRING
 ----- -24 V. } FIELD
 - - - - - LINE V. } WIRING

From Dwg. B801081 Rev. 2

OUTLINE DRAWING FOR 2/4TGB3F18,25, 30,36A

MINIMUM UNIT CLEARANCE TABLE		SERVICE CLEARANCE (RECOMMENDED)	
SIDES	0"	2"	
FRONT	0"	21"	
BACK	0"	0"	
INLET DUCT	0"	0"	
OUTLET DUCT	1"	1"	

* 1" FOR THE FIRST 3 FT. OF OUTLET DUCT WHEN ELECTRIC HEATERS ARE INSTALLED, EXCEPT MODELS BAYHTRI405, 1408, AND 1410 ARE APPROVED FOR 0" PLENUM AND DUCT CLEARANCE IN THE UPFLOW CONFIGURATION ONLY.

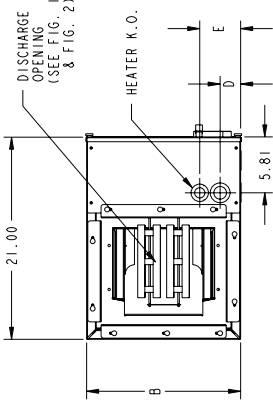

TOP VIEW

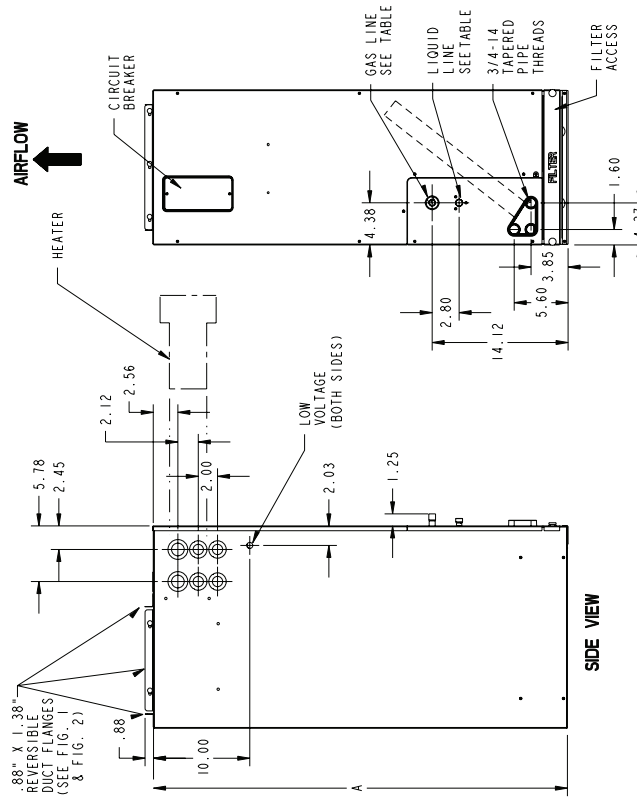

SIDE VIEW

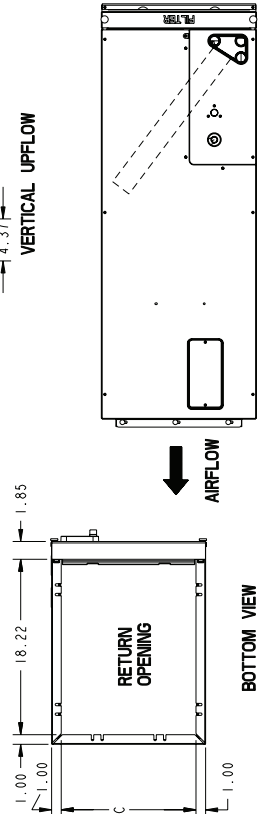

BOTTOM VIEW

HORIZ LEFT

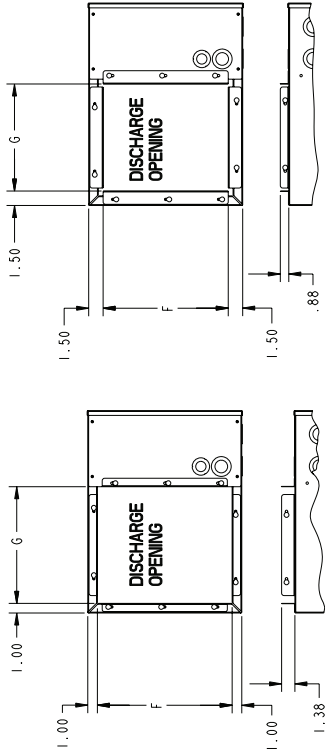

FIG. 2

FIG. 1

MODEL NO.	FIGURE 1			FIGURE 2		
	F	G	G	F	F	G
TWG018A	14.00	12.12	13.00	11.12		
TWG025A	16.00	12.12	15.00	11.12		
TWG030A	16.00	12.12	15.00	11.12		
TWG036A	16.00	12.12	15.00	11.12		
2/4TGB-18	16.00	12.12	15.00	11.12		
2/4TGB-25	16.00	12.12	15.00	11.12		
2/4TGB-30	16.00	12.12	15.00	11.12		
2/4TGB-36	16.00	12.12	15.00	11.12		

METRIC CONVERSION
INCHES X 25.4 MM

MODEL NO.	A	B	C	D	E	FLOW CONTROL	GAS LINE SIZE	LIQUID LINE SIZE
TWG018A	43.00	16.00	14.00	2.13	4.25	FCCV	5/8 BRAZE	1/4 BRAZE
TWG025A	45.70	18.00	16.00	3.13	5.25	FCCV	3/4 BRAZE	5/16 BRAZE
TWG030A	45.70	18.00	16.00	3.13	5.25	FCCV	3/4 BRAZE	5/16 BRAZE
TWG036A	52.00	18.00	16.00	3.13	5.25	FCCV	7/8 BRAZE	3/8 BRAZE
2TGB-18	45.70	18.00	16.00	3.13	5.25	TXV	5/8 BRAZE	1/4 BRAZE
2TGB-25	45.70	18.00	16.00	3.13	5.25	TXV	3/4 BRAZE	5/16 BRAZE
2TGB-30	52.00	18.00	16.00	3.13	5.25	TXV	3/4 BRAZE	5/16 BRAZE
2TGB-36	52.00	18.00	16.00	3.13	5.25	TXV	7/8 BRAZE	3/8 BRAZE
4TGB-18	45.70	18.00	16.00	3.13	5.25	TXV	1/2 BRAZE	3/8 BRAZE
4TGB-25	45.70	18.00	16.00	3.13	5.25	TXV	5/8 BRAZE	3/8 BRAZE
4TGB-30	52.00	18.00	16.00	3.13	5.25	TXV	3/4 BRAZE	3/8 BRAZE
4TGB-36	52.00	18.00	16.00	3.13	5.25	TXV	3/4 BRAZE	3/8 BRAZE

I. CHECKOUT PROCEDURE

1. Check the Air Handler installation in accordance with this instruction.
2. "Operational Procedure" for the system installation can be found in the outdoor unit installer guide and will be compatible with this Air Handler.

CHECKOUT PROCEDURES

After installation has been completed, it is recommended that the Air Handler be checked against the following checklist.

- | | |
|--|--|
| 1. Make sure power is "OFF" at power disconnect switch..... [] | 6. Make sure secondary drain pan is installed..... [] |
| 2. Check all field wiring for tight connections. See that grounding of unit is in accord with code..... [] | 7. Check power supply for correct requirements per unit nameplate..... [] |
| 3. Make sure unit suspension (if used) is secure and that there are no tools or loose debris in, around or on top of the unit..... [] | 8. Check filters for proper size. Inform owner of proper procedure for removal and reinstallation..... [] |
| 4. Check all duct outlets; they must be open and unrestricted..... [] | 9. Energize the system and carefully observe its operation; make any necessary adjustment..... [] |
| 5. Check drain lines and be sure all joints are tight. [] | 10. Instruct owner, engineer (if possible) on proper operating procedure and leave Use and Care Manual with owner..... [] |

SUPPLEMENTARY HEATERS CHECKOUT PROCEDURES

IF a heater is USED, see "limitations and recommendations" to determine if the heater requires a SPECIAL CIRCUIT.

1. Be sure the disconnect switch is "OFF", and safety label (if any) is attached..... []
2. Check on field wiring for tight connections and grounding according to codes..... []
3. Check circuit protection for proper size per nameplate specifications..... []
4. Check control box panel — in place and secured..... []

NOTE:

OPERATION OF HEATERS MUST BE CHECKED DURING THE OPERATIONAL CHECK OF THE TOTAL SYSTEM.