

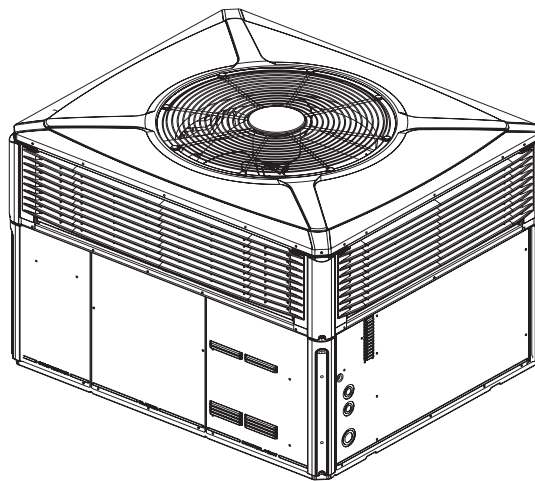
# Installer's Guide

## Single Packaged, Cooling w/ Electric Heat, 14 SEER, Convertible, 2 - 5 Ton, R-410A

ALL phases of this installation must comply with NATIONAL, STATE AND LOCAL CODES

**IMPORTANT** — This Document is customer property. Please return to service information pack and give this Installer's Guide to the homeowner upon completion of work.

4TCY4024 through 4TCY4060



**⚠ WARNING: HAZARDOUS VOLTAGE - DISCONNECT POWER and DISCHARGE CAPACITORS BEFORE SERVICING**

### ⚠ WARNING

#### SAFETY HAZARD!

This information is for use by individuals having adequate backgrounds of electrical and mechanical experience. Any attempt to repair a central air conditioning product may result in personal injury and/or property damage. The manufacturer or seller cannot be responsible for the interpretation of this information, nor can it assume any liability in connection with its use.

### ⚠ WARNING

#### WARNING!

This product can expose you to chemicals including lead, which are known to the State of California to cause cancer and birth defects or other reproductive harm. For more information go to [www.P65Warnings.ca.gov](http://www.P65Warnings.ca.gov)

### ⚠ WARNING

#### SAFETY HAZARD!

Bodily injury can result from high voltage electrical components, fast moving fans, and combustible gas. For protection from these inherent hazards during installation and service, the electrical supply must be disconnected and the main gas valve must be turned off. If operating checks must be performed with the unit operating, it is the technician's responsibility to recognize these hazards and proceed safely.

# Installer's Guide

## Safety Considerations

**IMPORTANT:** Read this entire manual before beginning installation procedures.

### NOTICE

Warning and Cautions appear at appropriate locations throughout this guide. Your personal safety and the proper operation of this air conditioning product require that you follow them carefully. The manufacturer assumes no liability for installations or servicing performed by unqualified personnel.

**⚠ WARNING:** INDICATES A POTENTIALLY HAZARDOUS SITUATION WHICH, IF NOT AVOIDED, COULD RESULT IN DEATH OR SERIOUS INJURY.

**⚠ CAUTION:** Indicates a potentially hazardous situation which, if not avoided, may result in minor or moderate injury. It may also be used to alert against unsafe practices and where property-damage-only accidents could occur.

### ⚠ WARNING

#### SAFETY HAZARD!

Do not operate the unit without the evaporator fan or coil access panels in place. Reinstall the access panels after performing maintenance procedures on the fan. Operating the unit without the access panels properly installed may result in severe personal injury or death.

### ⚠ WARNING

#### EXPLOSION HAZARD!

To prevent an explosion or possible injury, death, and equipment damage. Do not store combustible materials, gasoline, or other flammable vapors or liquids near the unit.

### ⚠ WARNING

#### CONTAINS REFRIGERANT!

SYSTEM CONTAINS OIL AND REFRIGERANT UNDER HIGH PRESSURE. RECOVER REFRIGERANT TO RELIEVE PRESSURE BEFORE OPENING SYSTEM. Failure to follow proper procedures can result in personal illness or injury or severe equipment damage.

### ⚠ WARNING

Unit contains R-410A Refrigerant!  
R-410A operating pressure exceeds the limit of R-22. Proper service equipment is required. Failure to use proper service tools may result in equipment damage or personal injury.

#### SERVICE

Use only R-410A Refrigerant and approved POE compressor oil.

### ⚠ WARNING

This product contains fiberglass wool insulation! Fiberglass dust and ceramic fibers are believed by the state of California to cause cancer through inhalation. Glasswool fibers may also cause respiratory, skin, or eye irritation.

#### PRECAUTIONARY MEASURES

- Avoid breathing fiberglass dust
- Use a NIOSH approved dust/mist respirator
- Avoid contact with the skin or eyes. Wear long-sleeved, loose fitting clothing, gloves, and eye protection.
- Wash clothes separately from other clothing, rinse washer thoroughly.
- Operations, such as sawing, blowing, tear-out, and spraying may generate fiber concentrations requiring additional respiratory protection. Use the appropriate NIOSH approved respirator in these situations.

#### FIRST AID MEASURES

**Eye Contact:** Flush eyes with water to remove dust. If symptoms persist, seek medical attention.

**Skin Contact:** Wash affected area gently with soap and warm water after handling.

### ⚠ CAUTION

Reconnect all grounding devices.

All parts of this product that are capable of conducting electrical current are grounded. If grounding wires, screws, straps, clips, nuts, or washers used to complete a path to ground are removed for service, they must be returned to their original position and properly fastened.

### ⚠ CAUTION

Hot Surface!

Do Not touch top of compressor. May cause minor to severe burning.

**IMPORTANT:** Proper refrigerant charge and proper air flow are critical to achieve rated capacity and efficiency. Installation of this product should follow the manufacturer's refrigerant charging and air flow instructions. **Failure to confirm proper charge and airflow may reduce energy efficiency and shorten equipment life.**

**Note:** The packaged units have been evaluated in accordance with the Code of Federal Regulations, Chapter XX, Part 3280 or the equivalent.

"SUITABLE FOR MOBILE HOME USE."

**IMPORTANT:** Wear appropriate gloves, arm sleeve protectors, and eye protection when servicing or maintaining this equipment.

## Contents

Safety Considerations	2
Introduction	3
Step 1-Inspect Shipment	3
Step 2-Determine Unit Clearances	4
Step 3-Review Location & Recommendation Information	10
Step 4-Unit Installation	11
Ground Level Installation	11
Rooftop Installation -- Curb Mounting	11
Covert Horizontal Airflow to Down Airflow	11
Install Full Perimeter Roof Mounting Curb	11
Lifting and Rigging	12
Placing the Unit on the Mounting Curb	12
Rooftop Installation -- Frame Mounting	13
Rooftop Installation -- No Frame/Curb	13
Ductwork Installation	16
Attaching Downflow Ductwork to Roof Curb	16
Attaching Downflow Ductwork to Roof Frame	16
Attaching Horizontal Ductwork to Unit	16
Condensate Drain Piping	16
Air Filter Installation	16
Electrical Wiring	17
Electrical Connections	17
Electrical Power	17
Disconnect Switch	17
Overcurrent Protection	17
Power Wiring	17
Field Wiring Diagram	18
Control Wiring (Class II)	19
Thermostat Heat Anticipator	19
Step 5-Unit Startup	19
Pre-start Quick Checklist	19
Starting the Unit in the Cooling Mode	19
Operating Pressures	19
Voltage Check	19
Cooling Shutdown	19
Starting the Unit in Heating Mode	20
Heating Shutdown	20
Sequence of Operation	20
General	20
Cooling Mode	20
Heating Mode	20
Final Inspection Checklist	20
Maintenance	20
Owner Maintenance	20
Service Maintenance	21
Cooling Season	21
Heating Season	21
ECM Fan Motor Adjustments	21

## Introduction

Read this manual carefully before attempting to install, operate, or perform maintenance on this unit. Installation and maintenance should be performed by qualified service technicians only. This unit is listed by Underwriters Laboratory.

Packaged units are designed for outdoor mounting with a vertical condenser discharge. They can be located either at ground level or on a roof in accordance with local codes. Each unit contains an operating charge of refrigerant as shipped.

The indoor fan motor speed adjustment is provided in the Maintenance section.

Extreme mounting kits are available for slab (BAYEXM-K003A), curb (BAYEXMK001A), and utility curb (BAYEX-MK0002B) mountings.

Supplemental heaters are installed separately per the appropriate Supplemental Electric Heaters Installer's Guide.

Single power entry kits are installed separately per the appropriate Single Power Entry Kit Installer's Guide.

This guide is organized as follows:

- Step 1 - Inspect Shipment
- Step 2 - Determine Unit Clearances
- Step 3 - Review Location & Recommendation Information
- Step 4 - Unit Installation
- Step 5 - Unit Startup
- Sequence of Operation
- Maintenance

## Step 1 – Inspect Shipment

- Check for damage after the unit is unloaded. Report promptly to the carrier any damage found to the unit. Do not drop the unit.
 

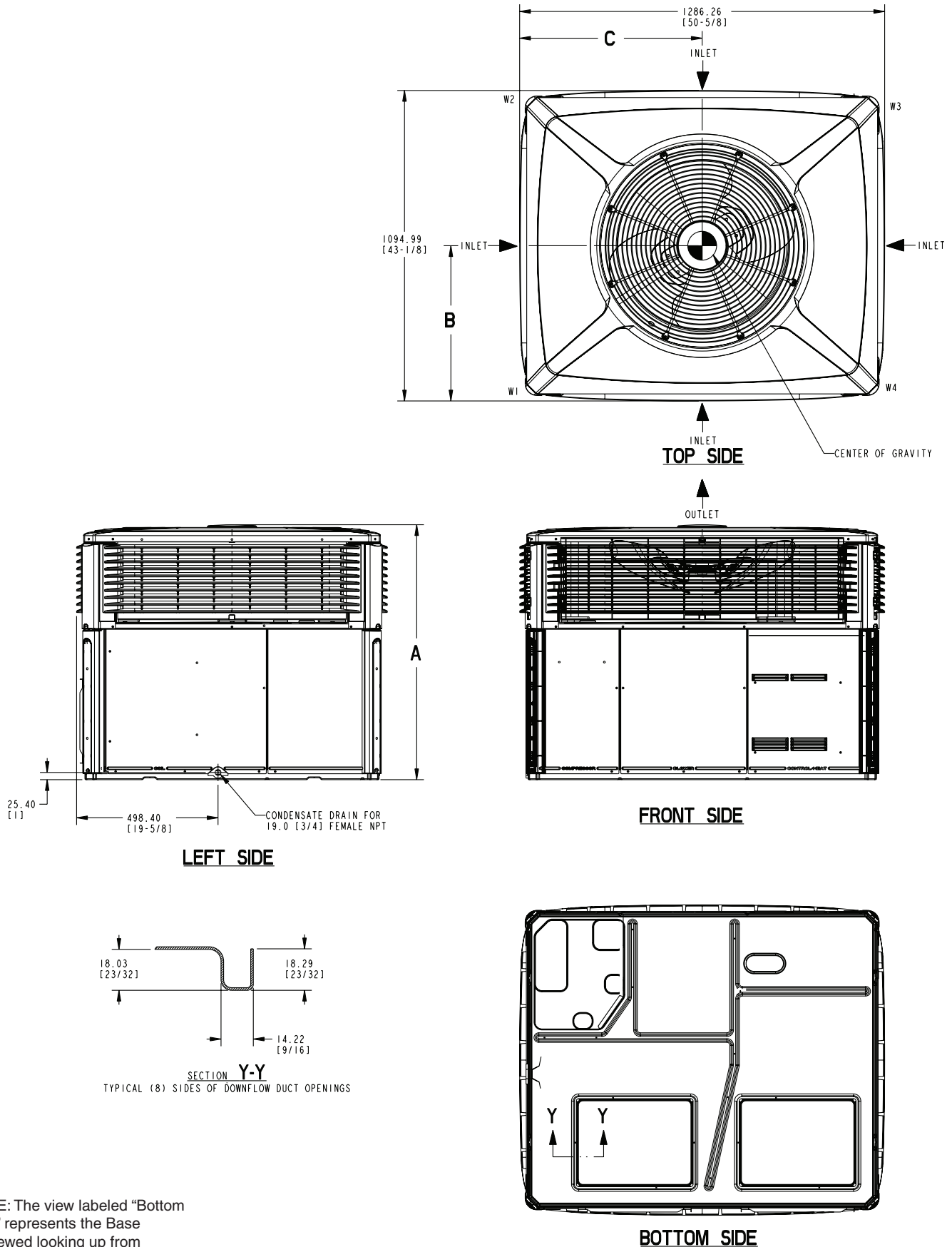
**IMPORTANT:** To prevent damage to the sides and top of the unit when hoisting, use "spreader bars" as shown on page 14.
- Check the unit's nameplate to determine if the unit is correct for the intended application. The power supply must be adequate for both the unit and all accessories.
- Check to be sure the refrigerant charge has been retained during shipment. Remove the Compressor access panel to access the 1/4" flare pressure taps.
- If this unit is being installed on a curb, verify that the correct curb is provided with the unit.
  - 4TCY4024 through 4TCY4036 use BAYCURB050A.
  - 4TCY4042 through 4TCY4060 use BAYCURB051A.
- If the unit is being hoisted, accessory kit BAYLIFT002A is recommended. It includes a kit of four (4) lifting lugs and instructions.

**NOTE:** *If practical, install any internal accessories to the unit at the shop.*

# Installer's Guide

## Step 2—Determine Unit Clearances

Figures 1 to 6 show the unit critical dimensions.

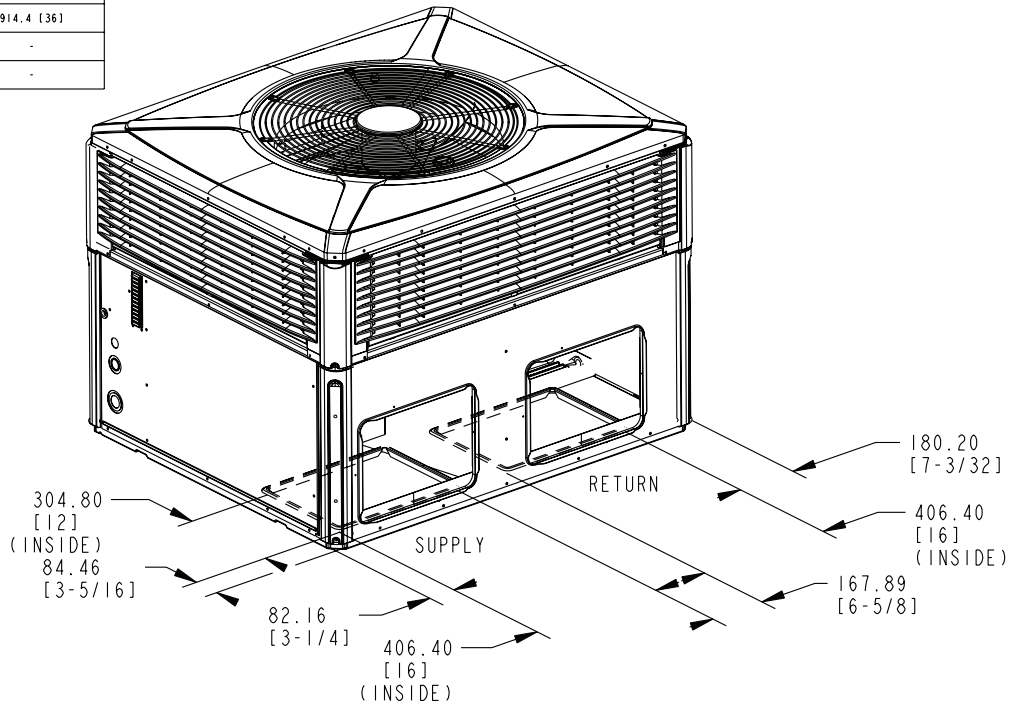


NOTE: The view labeled "Bottom Side" represents the Base as viewed looking up from underneath the unit.

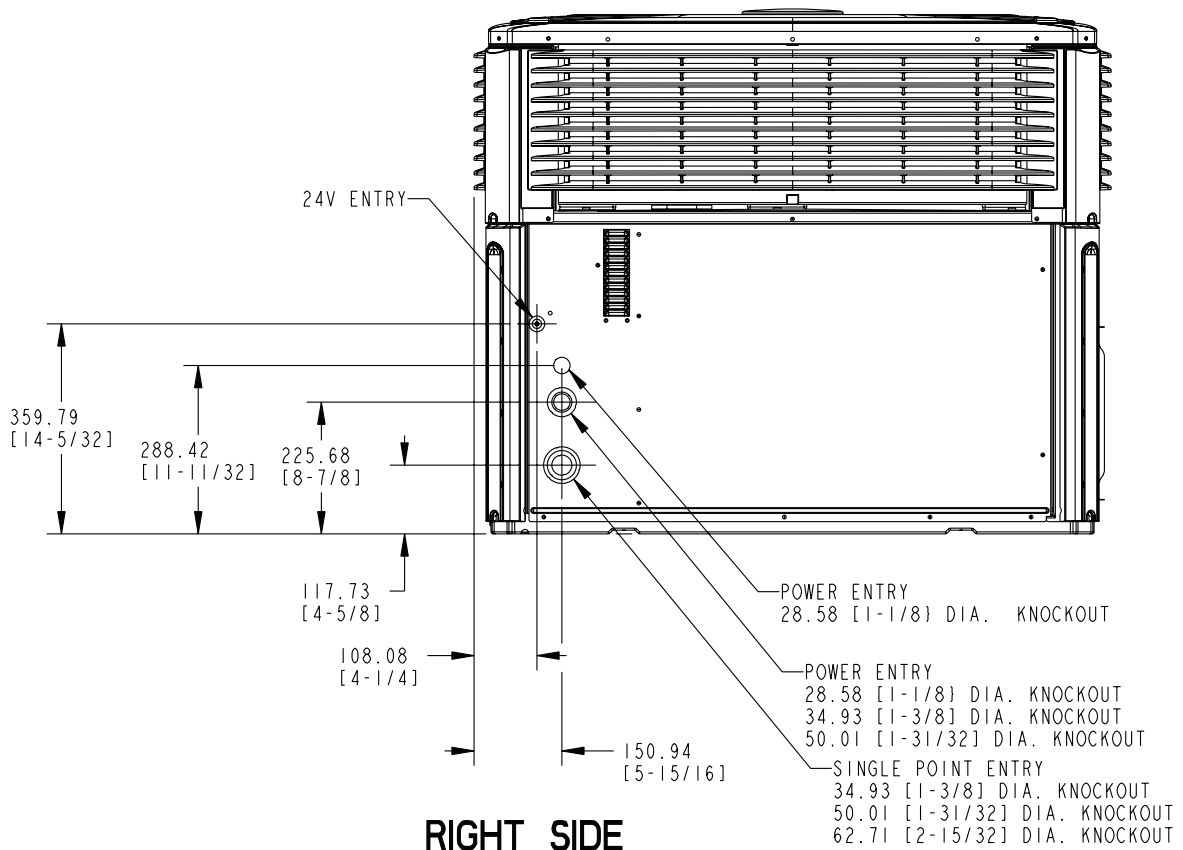
Figure 1. 4TCY4024 through 4TCY4036 (1 of 3)

RECOMMENDED SERVICE CLEARANCE MM/IN.		
		WITH ECONOMIZER
BACK SIDE	304.8 [12]	762.0 [30]
LEFT SIDE	762.0 [30]	914.4 [36]
RIGHT SIDE	609.6 [24]	-
FRONT SIDE	1066.8 [42]	-

CLEARANCE TO COMBUSTIBLE MATERIAL MM/IN.	
BOTTOM	0
BACK SIDE	25.4 [1]
LEFT SIDE	152.4 [6]
RIGHT SIDE	152.4 [6]
FRONT SIDE	304.8 [12]
TOP	914.4 [36]

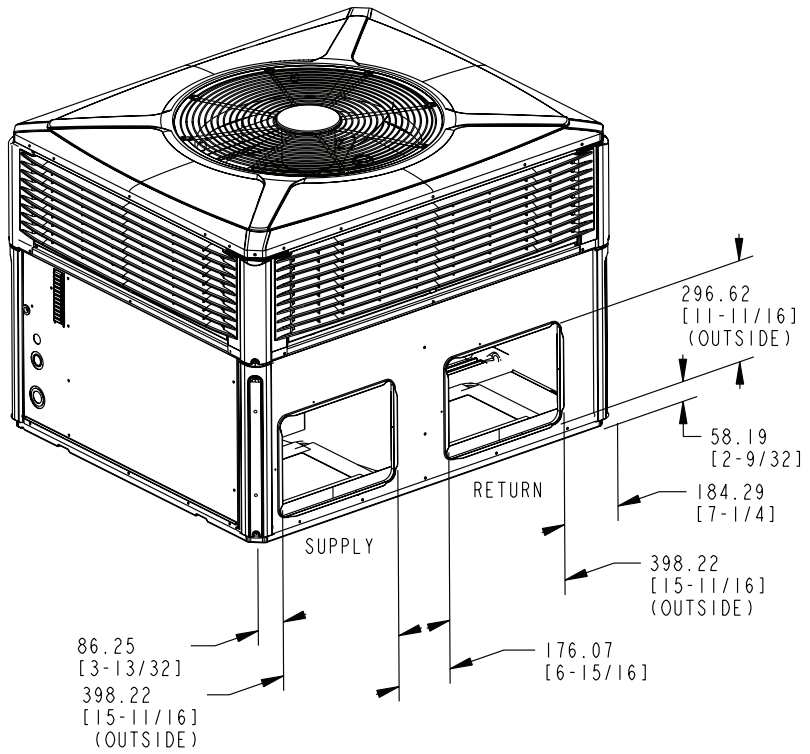


## BOTTOM DUCT OPENINGS

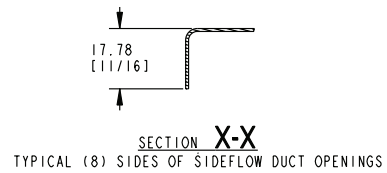
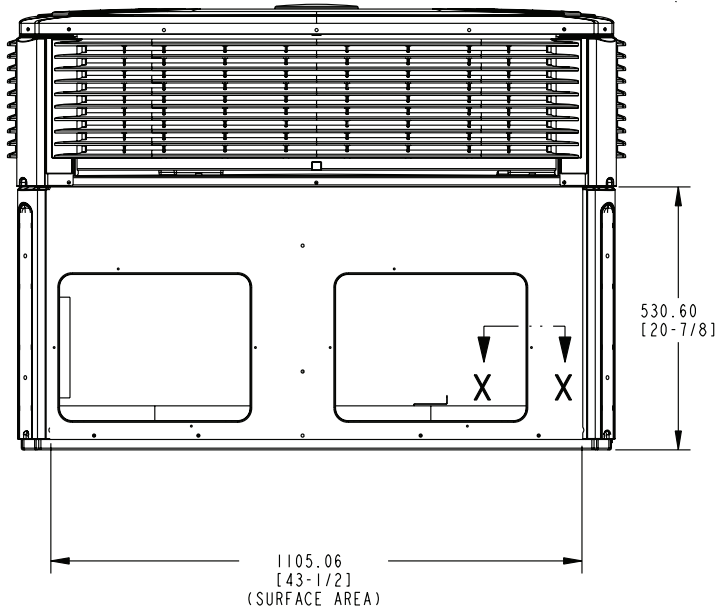


## RIGHT SIDE

Figure 2. 4TCY4024 through 4TCY4036 (2 of 3)



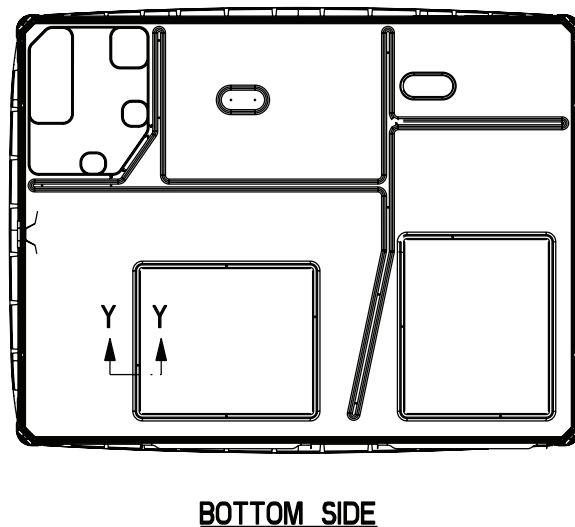
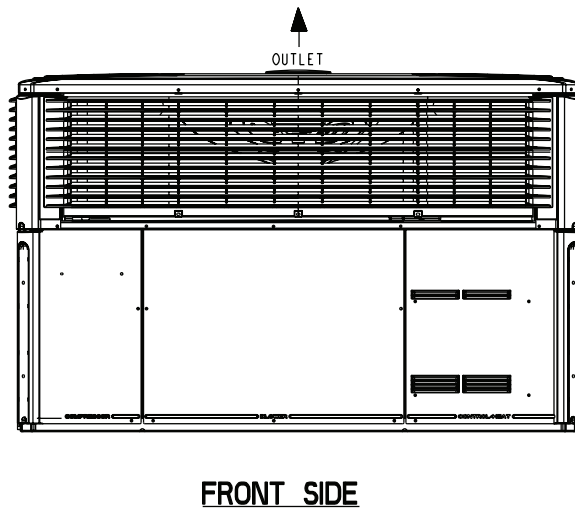
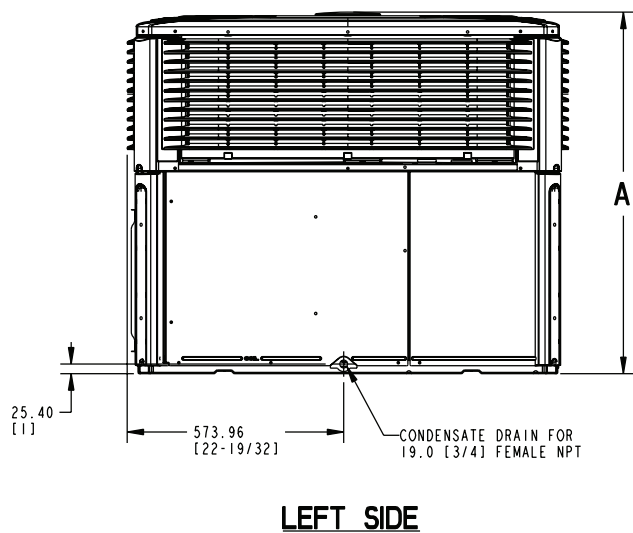
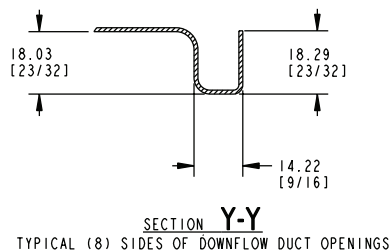
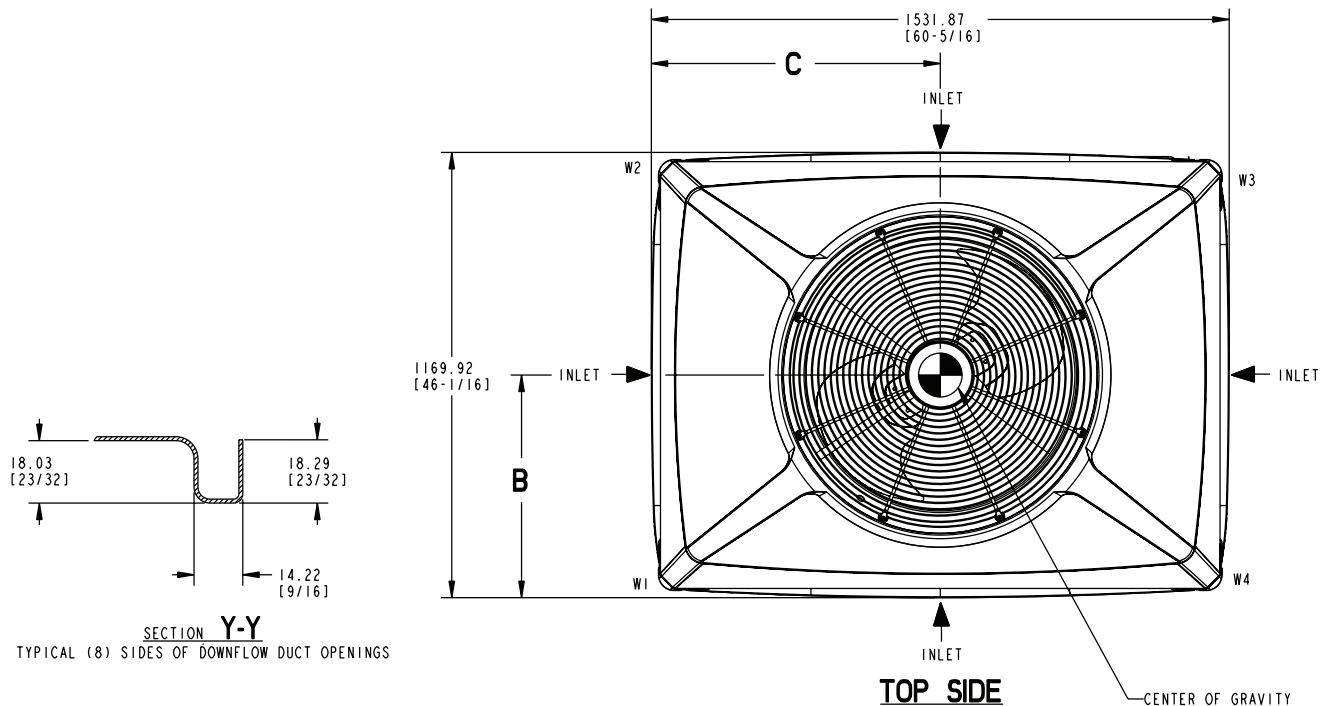
## BACK DUCT OPENINGS



## BACK SIDE

MODEL	HEIGHT MM/IN.	APPROX. CORNER WEIGHT - KG/LBS				SHIPPING WEIGHT KG/LBS	TOTAL UNIT WEIGHT KG/LBS	CENTER OF GRAVITY MM/IN.	
	A	W1	W2	W3	W4			B	C
4TCY4024/030	898.53 [35-3/8]	56.7 [125]	35.8 [79]	25.4 [56]	39.9 [88]	201.6 [444]	157.9 [348]	401.3 [15.8]	508.0 [20.0]
4TCY4036	949.33 [37-3/8]	57.6 [127]	36.3 [80]	25.9 [57]	40.8 [90]	204.3 [450]	160.6 [354]	401.3 [15.8]	508.0 [20.0]
4WCY4024/030	898.53 [35-3/8]	57.6 [127]	36.3 [80]	26.3 [58]	41.7 [92]	205.7 [453]	161.9 [357]	401.3 [15.8]	515.6 [20.3]
4WCY4036	949.33 [37-3/8]	60.8 [134]	38.1 [84]	27.2 [60]	42.6 [94]	212.5 [468]	168.7 [372]	401.3 [15.8]	508.0 [20.0]
4WCZ6036	949.33 [37-3/8]	60.8 [134]	38.1 [84]	27.2 [60]	42.6 [94]	212.5 [468]	168.7 [372]	401.3 [15.8]	508.0 [20.0]

Figure 3. 4TCY4024 through 4TCY4036 (3 of 3)



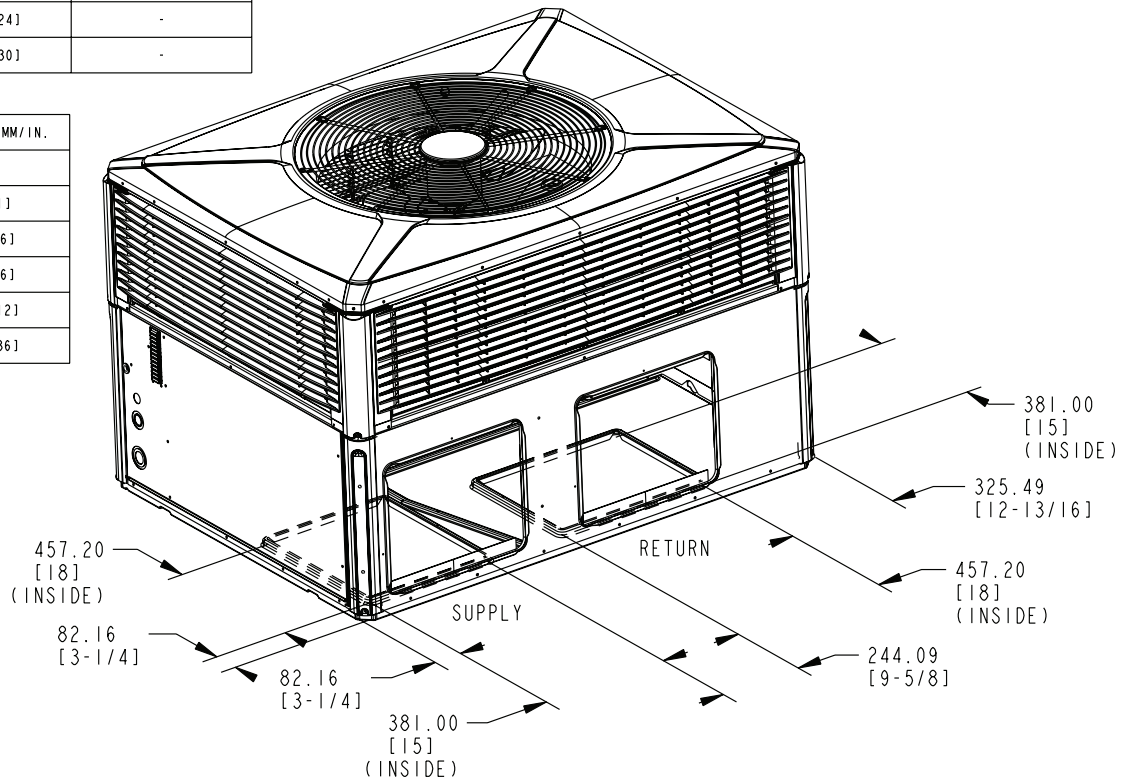
NOTE: The view labeled "Bottom Side" represents the Base as viewed looking up from underneath the unit.

Figure 4. 4TCY4042 through 4TCY4060 (1 of 3)

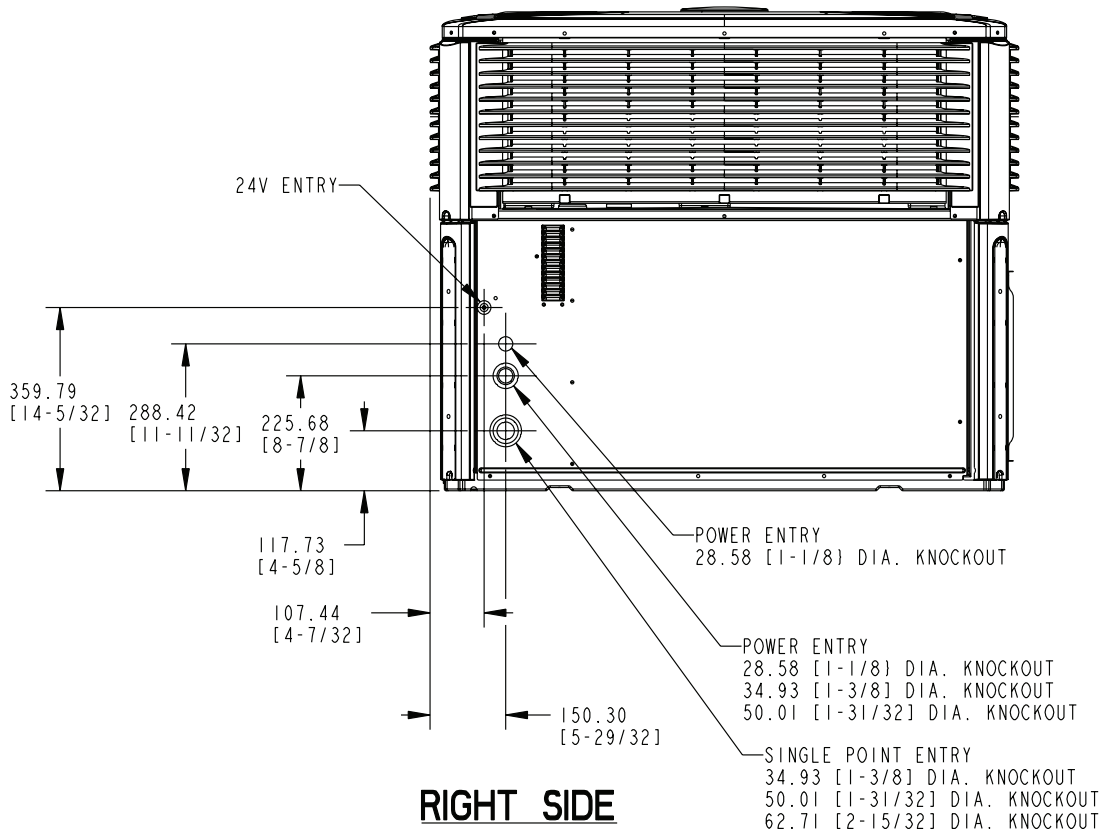
# Installer's Guide

RECOMMENDED SERVICE CLEARANCE MM/IN.		
		WITH ECONOMIZER
BACK SIDE	304.8 [12]	762.0 [30]
LEFT SIDE	914.4 [36]	1066.8 [42]
RIGHT SIDE	609.6 [24]	-
FRONT SIDE	762.0 [30]	-

CLEARANCE TO COMBUSTIBLE MATERIAL MM/IN.	
BOTTOM	0
BACK SIDE	25.4 [1]
LEFT SIDE	152.4 [6]
RIGHT SIDE	152.4 [6]
FRONT SIDE	304.8 [12]
TOP	914.4 [36]



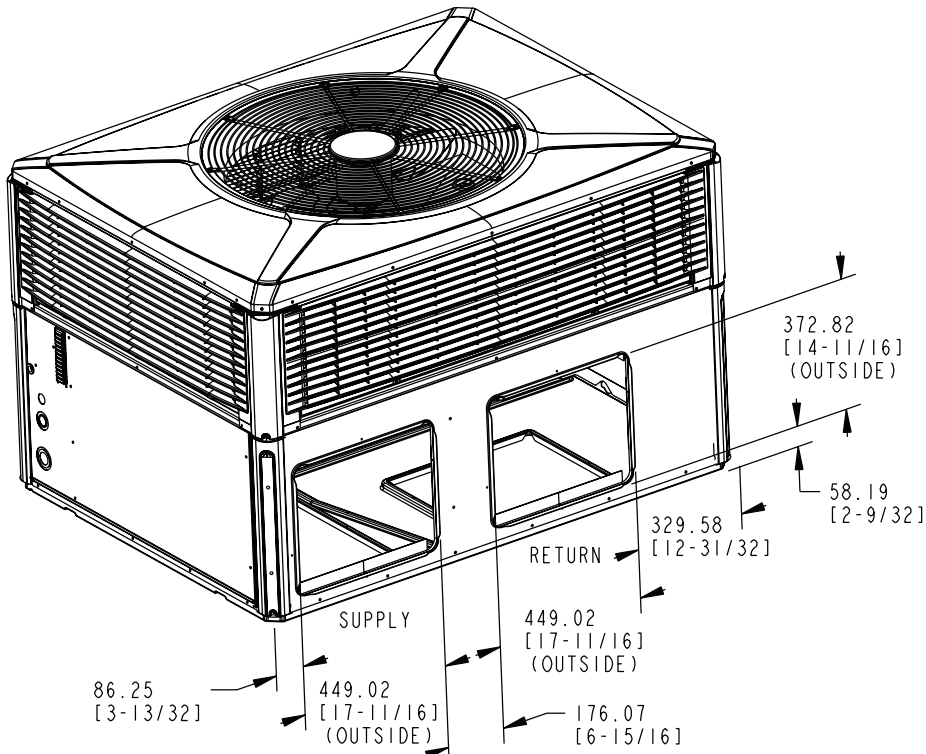
## BOTTOM DUCT OPENINGS



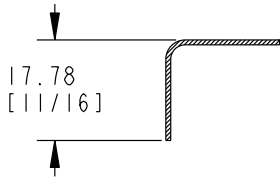
## RIGHT SIDE

Figure 5. 4TCY4042 through 4TCY4060 (2 of 3)



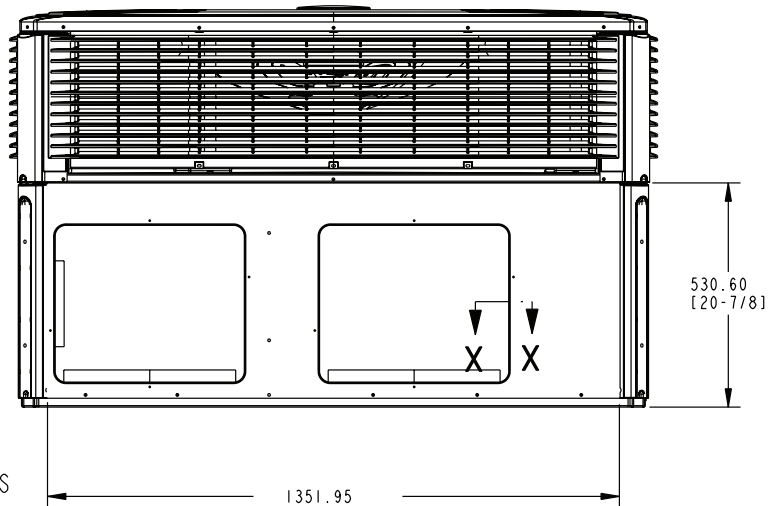


## BACK DUCT OPENINGS



### SECTION X-X

TYPICAL (8) SIDES OF SIDEFLOW DUCT OPENINGS



## BACK SIDE

MODEL	HEIGHT MM/IN.	APPROX. CORNER WEIGHT - KG/LBS				SHIPPING WEIGHT KG/LBS	TOTAL UNIT WEIGHT KG/LBS	CENTER OF GRAVITY MM/IN.	
		A	W1	W2	W3			W4	B
4TCY4042/048A	949.33 [37-3/8]	76.2 [168]	47.6 [105]	35.8 [79]	57.6 [127]	275.6 (607)	217.3 [479]	426.7 [16.8]	635.0 [25.0]
4TCY4048B	949.33 [37-3/8]	78.0 [172]	49.4 [109]	37.6 [83]	59.4 [131]	282.5 [623]	224.4 [495]	426.7 [16.8]	635.0 [25.0]
4TCY4060	1050.93 [41-3/8]	78.9 [174]	46.7 [103]	34.9 [77]	59.1 [130]	277.8 (612)	219.5 [484]	414.0 [16.3]	635.0 [25.0]
4WCY4042/048A	949.33 [37-3/8]	68.9 [152]	40.8 [90]	30.8 [68]	52.2 [115]	275.6 (607)	217.5 [479]	414.0 [16.3]	635.0 [25.0]
4WCY4048B	949.33 [37-3/8]	78.0 [172]	49.4 [109]	37.6 [83]	59.4 [131]	282.5 [623]	224.4 [495]	414.0 [16.3]	635.0 [25.0]
4WCY4060	1050.93 [41-3/8]	80.3 [177]	47.6 [105]	35.8 [79]	60.8 [134]	282.8 (623)	224.5 [495]	414.0 [16.3]	635.0 [25.0]
4WCZ6048	1050.93 [41-3/8]	68.9 [152]	40.8 [90]	30.8 [68]	52.2 [115]	275.6 (607)	217.5 [479]	414.0 [16.3]	635.0 [25.0]
4WCZ6060	1050.93 [41-3/8]	80.3 [177]	47.6 [105]	35.8 [79]	60.8 [134]	282.8 (623)	224.5 [495]	414.0 [16.3]	635.0 [25.0]

Figure 6. 4TCY4042 through 4TCY4060 (3 of 3)

## Step 3—Review Location and Recommendation Information

### CAUTION

Caution must be taken at all times to avoid personal injuries and/or damage to equipment.

*NOTE: The unit is shipped for horizontal installation.*

#### **Horizontal Airflow Units**

1. Location of the unit must allow service clearance around it to ensure adequate serviceability, maximum capacity, and peak operating efficiency.
2. These units are design for outdoor installation. They may be installed directly on a slab, wood flooring, or on Class A, B, or C roof covering material. The discharge air from the condenser fans must be unrestricted for a minimum of 3 feet above the unit.
3. Check the handling facilities to ensure the safety of personnel and the unit.
4. The unit must be mounted level for proper drainage of water through the drain holes in the base pan.
5. The unit should not be exposed to direct roof water runoff.
6. Flexible duct connectors must be of a flame retardant material. All duct work outside of the structure must be insulated and weatherproofed in accordance with local codes.
7. Holes through exterior walls or roof must be sealed in accordance with local codes.
8. All fabricated outdoor ducts should be as short as possible.

#### **Clearances**

1. The recommended clearances for single-unit installations are illustrated in Figures 1 through 6 pages 4-9.
2. Any reduction of the unit clearances indicated in these figures may result in condenser coil starvation or the recirculation of warm condenser air. Actual clearances, which appear to be inadequate should be reviewed with a local engineer.
3. See the unit's nameplate for the absolute minimum clearance between the unit and any combustible surfaces.

#### **Down Airflow Units**

1. Location of the unit must allow service clearance around it to ensure adequate serviceability, maximum capacity, and peak operating efficiency.
2. Refer to the Installation section for instruction on converting the supply and return airflow covers to down airflow.
3. The field assembled Roof Mounting Curb (BAYCURB050A or BAYCURB051A) or a field fabricated curb should be in place before the unit is hoisted to the roof top.  
  
The Roof Mounting Curb (frame) must be installed on a flat, level section of the roof (maximum of 1/4" per foot pitch) and provide a level mounting surface for the unit. Also, be sure to provide sufficient height above the roof to prevent water from entering the unit.
4. Be sure the mounting curb spans structural members (trusses) of the roof, thereby providing sufficient support for the weight of the unit, the curb, the duct(s), and any factory or field installed accessories.
5. The unit must be mounted level for proper drainage of water through the drain holes in the base pan.
6. Be sure the hole in the structure for the ducts is large enough to accommodate the fabricated ducts and the insulation surrounding them. Flexible duct connectors must be of a flame retardant material. All duct work outside of the structure must be insulated and weatherproofed in accordance with local codes.
7. Holes through exterior walls or roof must be sealed in accordance with local codes.
8. These units are design for outdoor installation. They may be installed directly on a slab, wood flooring, or on Class A, B, or C roof covering material. The discharge air from the condenser fans must be unrestricted for a minimum of 3 feet above the unit.
9. Check the handling facilities to ensure the safety of personnel and the unit(s).

#### **Clearances**

1. The recommended clearances for single-unit installations are illustrated in Figures 1 through 6, pages 4-9.
2. Any reduction of the unit clearances indicated in these figures may result in condenser coil starvation or the recirculation of warm condenser air. Actual clearances, which appear to be inadequate should be reviewed with a local engineer.
3. See the unit's nameplate for the absolute minimum clearance between the unit and any combustible surfaces.

## Step 4—Unit Installation

*NOTE: The factory ships this unit for horizontal installation.*

### Ground Level Installation

To install the unit at ground level:

1. Place the unit on a pad the size of the unit or larger. The unit must be mounted level for proper drainage of water through the holes in the base pan. To attach the unit securely to the slab, use extreme mounting kit, BAYEXMK003A.

The pad must not come in contact with the structure (see Figure 7). Be sure the outdoor portion of the supply and return air ducts are as short as possible.

Unit requires vibration support as indicated in Figure 7 below and in Figure 9 on page 13.

2. Location of the unit must allow service clearance around it. Clearance of the unit must be given careful consideration. See Figures 1 to 6, pages 4-9.

*NOTE: Any reduction of the unit clearances indicated in these illustrations may result in condenser coil starvation or the recirculation of warm condenser air. Actual clearances, which appear to be inadequate should be reviewed with a local engineer.*

**IMPORTANT:** A minimum 0" clearance to combustible material shall be maintained on air outlet duct.

3. Attach the supply and return air ducts to the unit as explained in the following Ductwork Installation section.
4. Flexible duct connectors must be of a flame retardant material. Insulate any ductwork outside of the structure with at least two (2) inches of insulation and weatherproof. There must be a weatherproof seal where the duct enters the structure.
5. Do not expose the unit to direct roof water runoff.
6. Seal all holes through exterior walls in accordance with local codes.
7. Continue with the following installation sections to complete the installation: Ductwork on page 16, Filter on page 16, and Electrical Wiring on page 17.

### Rooftop Installation -- Curb Mounting

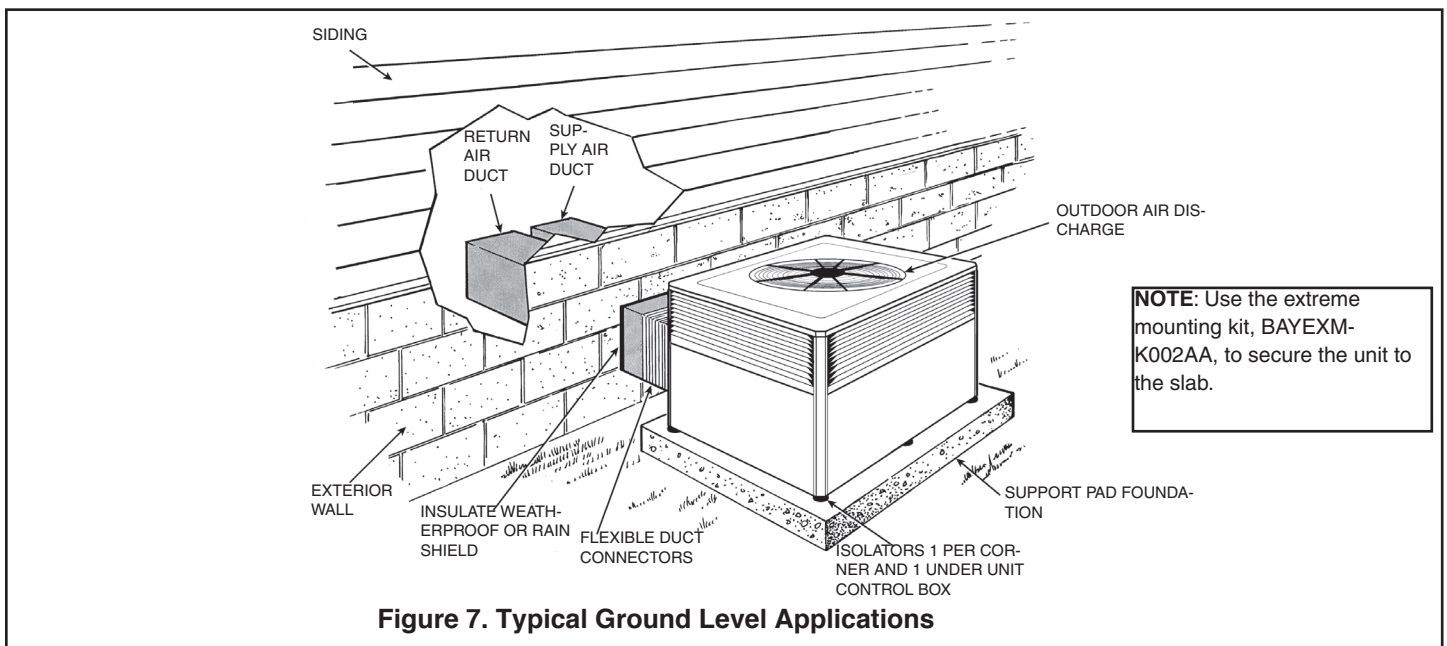
#### Convert Horizontal Airflow to Down Airflow

The factory ships the unit for horizontal airflow. Perform this procedure to convert it to down airflow:

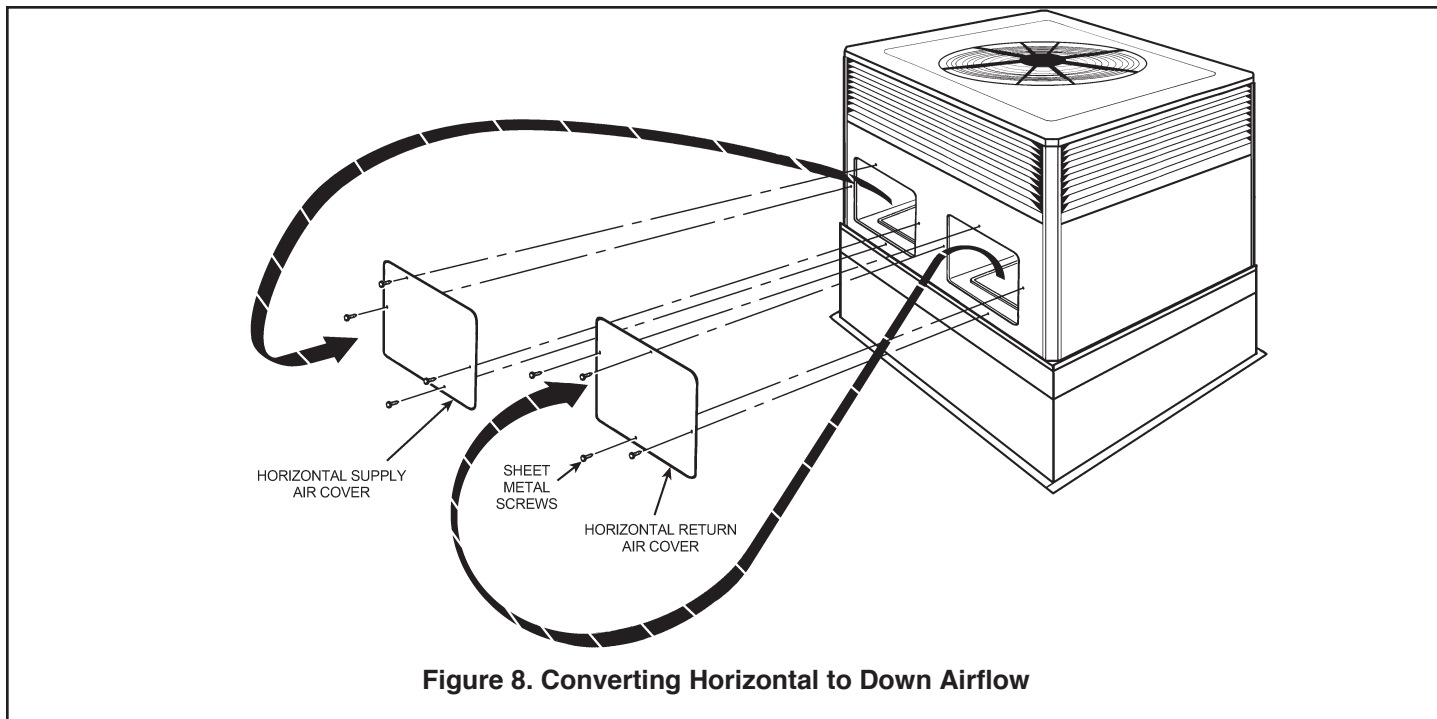
1. Remove the three (3) sheet metal screws securing the supply air cover and the four (4) sheet metal screws securing the return air cover from the base of the unit. Remove the covers from the base. See Figure 8, page 12.
2. Place the covers over the horizontal supply and return openings (painted side out). Align the screw holes, and secure using the same screws removed in step 1.

#### Install Full Perimeter Roof Mounting Curb

1. Verify that the roof mounting curb is correct for the unit. There are two curbs depending on the unit cabinet sizes:
  - 4TC\*3018 through 4TC\*3036 use model BAYCURB050A.
  - 4TC\*3042 through 4TC\*3060 use model BAYCURB051A.
2. Assemble and install the curb following the instructions in the Installer's Guide included with the appropriate curb.



**Figure 7. Typical Ground Level Applications**



## Lifting and Rigging

**IMPORTANT:** Do not lift the unit without test lifting for balance and rigging. Do not lift the unit in windy conditions or above personnel. Do not lift the unit by attaching clevis, hooks, pins, or bolts to the unit casing, casing hardware, corner lugs, angles, tabs, or flanges. Failure to observe these warnings may result in equipment damage.

1. Before preparing the unit for lifting, check the unit dimension drawings for center of gravity for lifting safety (Figures 1 to 6, page 4-9). Because of placement of internal components, the unit's weight may be unevenly distributed. Approximate unit weights are also provided in the unit drawings.

*NOTE: Unit rigging and hoisting requires accessory kit BAY-LIFT002A. It includes a kit of four (4) lifting lugs. See Figure 10 inset B, on page 14.*

2. Insert the four lifting lugs in the openings provided in the drip lip on each end of the unit. See Figure 10 inset B on page 14. A tap or jerk to the lug will overcome the interference that arises due to the dimple on the lug.
3. When hoisting the unit, be sure that a proper method of rigging is used. Use straps or slings and spreader bars for protection during lifting. Always test-lift the unit to determine the exact unit balance and stability before hoisting it to the installation location.
4. When the curb and air ducts have been properly installed, the unit is ready to be hoisted to the roof and set in position.

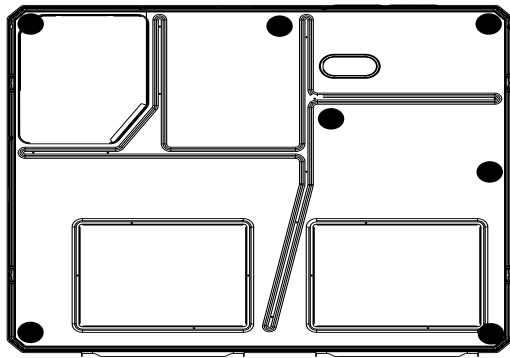
**IMPORTANT:** To prevent damage to the sides and top of the unit when hoisting, use "spreader bars" as shown on page 14.

**IMPORTANT:** The unit must be lowered into position. The P.V.C. rubber tape on the curb flange permits the unit to be repositioned if required without destroying the P.V.C. rubber seals affixed to the mounting curb.

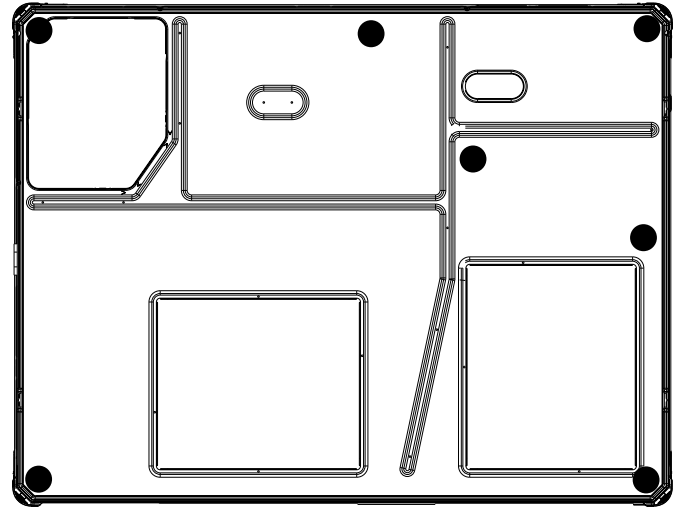
## Placing the Unit on the Mounting Curb

1. The unit is designed with a perimeter drip lip that is lower than the unit base pan, see Figure 10, inset A, on page 14.
2. Position the unit drip lip down over and in contact with the outside corner of the curb, as illustrated in Figure 10, inset A, on page 14. Continue to lower the unit on top of the curb, with the unit drip lip astraddle, and in contact with, both the end and side rail of the curb. The unit should now rest on top of the curb. Use the extreme mounting kit, BAYEXMK001A, to add additional hold down strength to the mounting.

*NOTE: The ductwork is installed as part of the curb installation. Do not attach ductwork to the unit and lower the unit with ductwork onto the curb.*



**Small Cabinet**  
\*\*\*\*018-036



**Medium Cabinet**  
\*\*\*\*042-060

*NOTE: These views represent the base as viewed looking up from underneath the unit.*

**IMPORTANT:** Unit requires vibration isolator support in the general areas shown. Locate 3/4" thick vibration isolators on the bottom of the basepan as illustrated by black dots for ground level pad applications. Modify vibration isolator location as necessary for frame and rail applications.

**Figure 9. Vibration Isolators/Snow Feet Locations**

## Rooftop Installation -- Frame Mounting

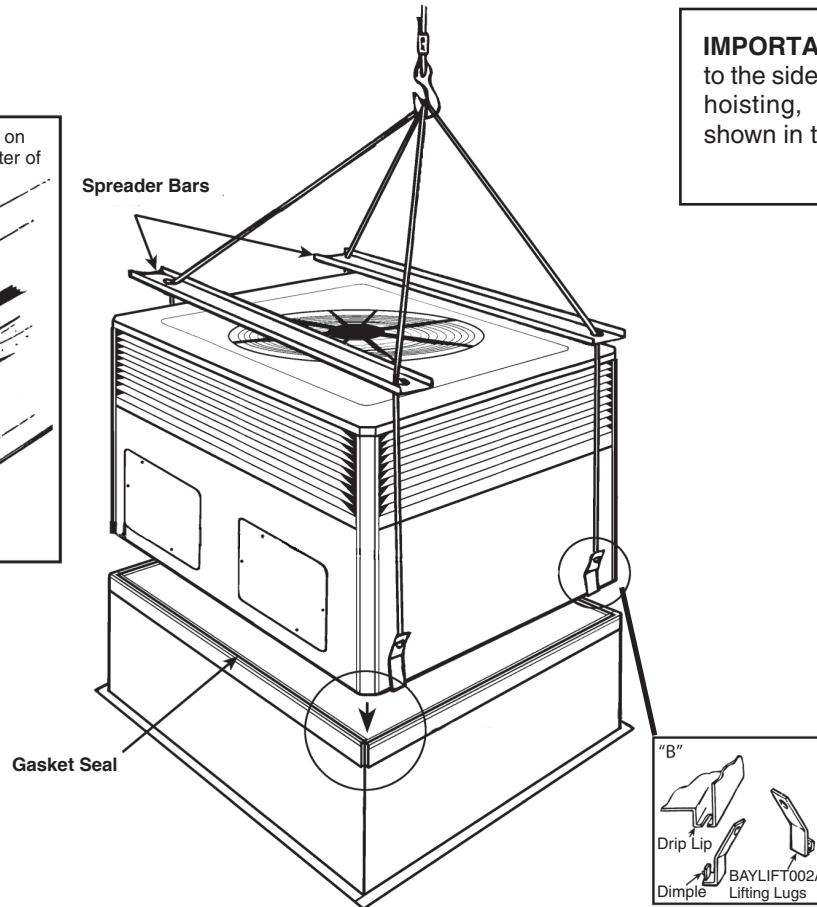
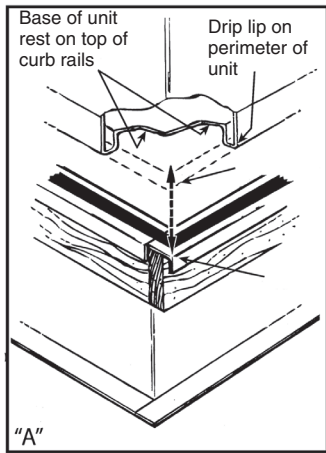
For roof top applications using field fabricated frame and ducts, use the following procedure:

1. Locate and secure the frame to the roof by bolting or welding. Frame must provide adequate center support via a cross member centrally located channel rail. See Figures 12 and 13 on page 15. Vibration isolators should be installed as indicated in Figure 9, adjust as necessary for your frame. The isolators must be placed on base pan, not drip lip. Add flashing as required. Flashing must conform to local building codes.
2. Prepare the hole in the roof in advance of installing the unit.
3. Secure the horizontal or down airflow ducts to the roof. Refer to the previous Convert from Horizontal Airflow to Down Airflow section on page 17, if conversion is needed.
4. All fabricated outdoor ducts should be as short as possible.
5. Place the unit on the frame. Refer to Figures 12 or 13 on page 15.
6. The unit must be mounted level for proper drainage of water through the holes in the base pan.
7. Secure the unit to the frame.
8. Insulate any ductwork outside of the structure with at least two (2) inches of insulation and then weatherproof. There must be a weatherproof seal where the duct enters the structure.
9. The unit should not be exposed to direct roof water runoff.
10. Flexible duct connectors must be of a flame retardant material. All duct work outside of the structure must be insulated and weatherproofed in accordance with local codes.
11. Access and service clearances for the unit must be given careful consideration when locating the duct entrance openings. Figures 1 to 6, on pages 4-9, provide unit dimensions.
12. Continue with the following installation sections to complete the installation: Ductwork on page 16, Filter on page 16, and Electrical Wiring on page 17.

## Rooftop Installation -- Flat Roof - No Curb/Frame

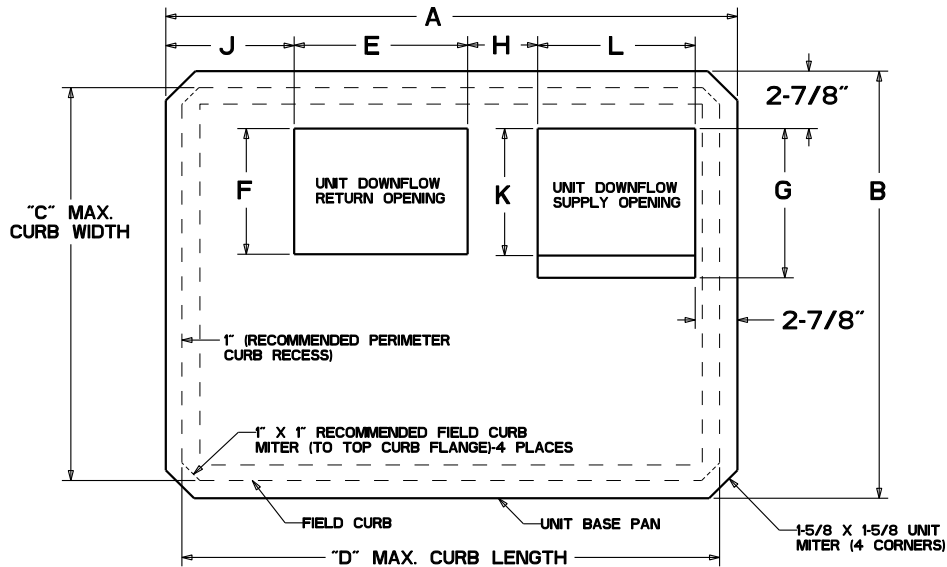
For roof top applications using field fabricated ducts and sleeper rails rather than a curb or frame, use the following procedure:

1. Locate and secure the sleeper rails to the roof by bolting. Three (3) sleeper rails are required. One on each end to support the edges of the unit and one across the center of the unit. The center rail must run inside both drip lips. Vibration isolators should be installed as indicated on Figure 9, adjust as necessary for your sleeper rails. The isolators must be placed on base pan, not drip lip. Add flashing as required. Flashing must conform to local building codes.
2. Prepare the hole in the roof in advance of installing the unit.
3. Secure the horizontal or down airflow ducts to the roof. Refer to the previous Convert from Horizontal Airflow to Down Airflow section on page 11, if conversion is needed.
4. All fabricated outdoor ducts should be as short as possible.
5. Place the unit on the rails.
6. The unit must be mounted level for proper drainage of water through the holes in the base pan.
7. Secure the unit to the rails.
8. Insulate any ductwork outside of the structure with at least two (2) inches of insulation and then weatherproof. There must be a weatherproof seal where the duct enters the structure.
9. The unit should not be exposed to direct roof water runoff.
10. Flexible duct connectors must be of a flame retardant material. All duct work outside of the structure must be insulated and weatherproofed in accordance with local codes.
11. Access and service clearances for the unit must be given careful consideration when locating the duct entrance openings. Figures 1 to 6, on pages 4-9, provide unit dimensions.
12. Continue with the following installation sections to complete the installation: Ductwork on page 16, Filter on page 16, and Electrical Wiring on page 17.



**IMPORTANT:** To prevent damage to the sides and top of the unit when hoisting, use "spreader bars" as shown in these illustrations.

**Figure 10. Lifting and Rigging**



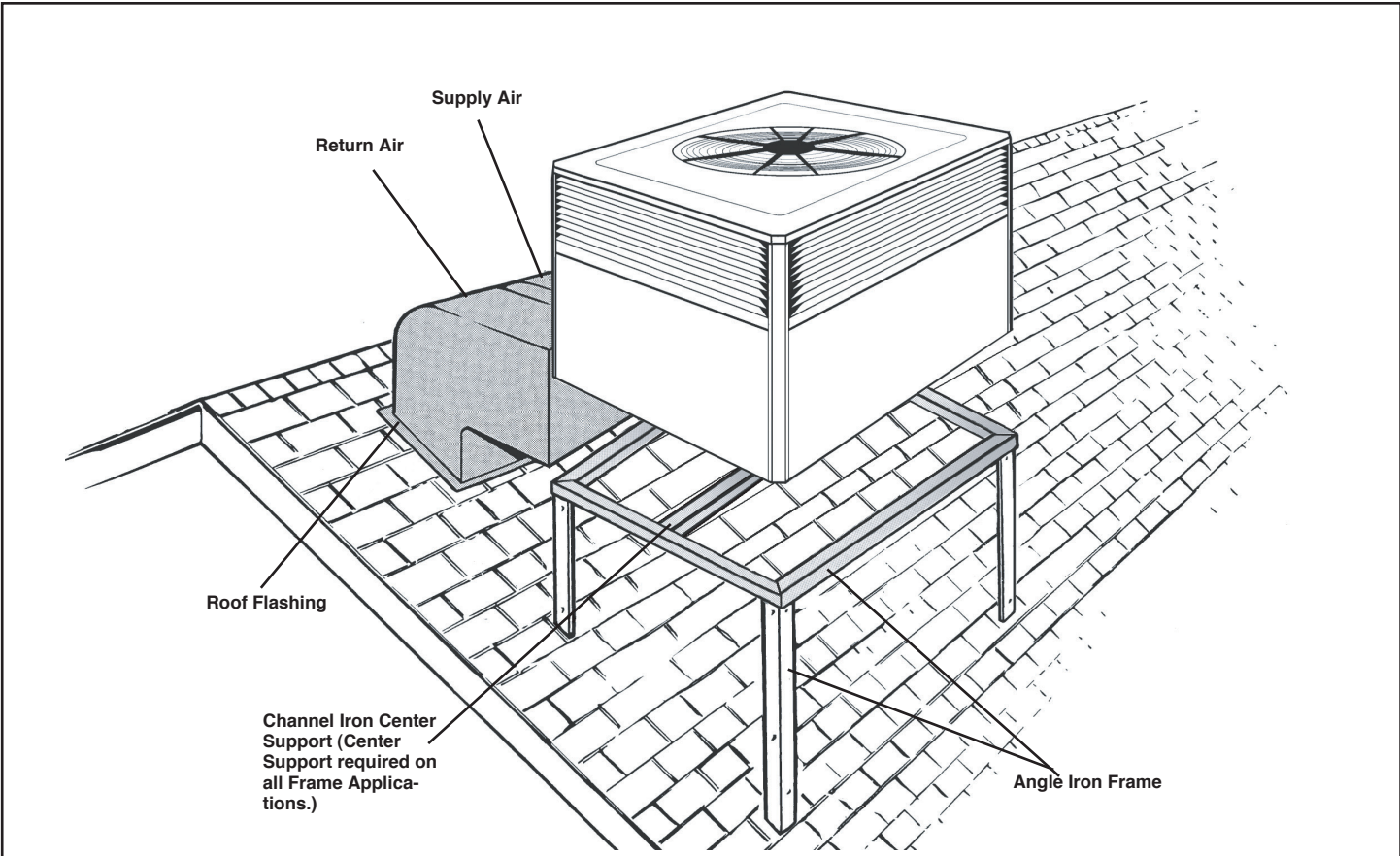
**TOP VIEW OF UNIT BASE PAN WITH FIELD CURB BELOW  
REFERENCE ILLUSTRATION FOR A CUSTOMER SUPPLIED ROOF CURB**

PRINTED FROM D674152

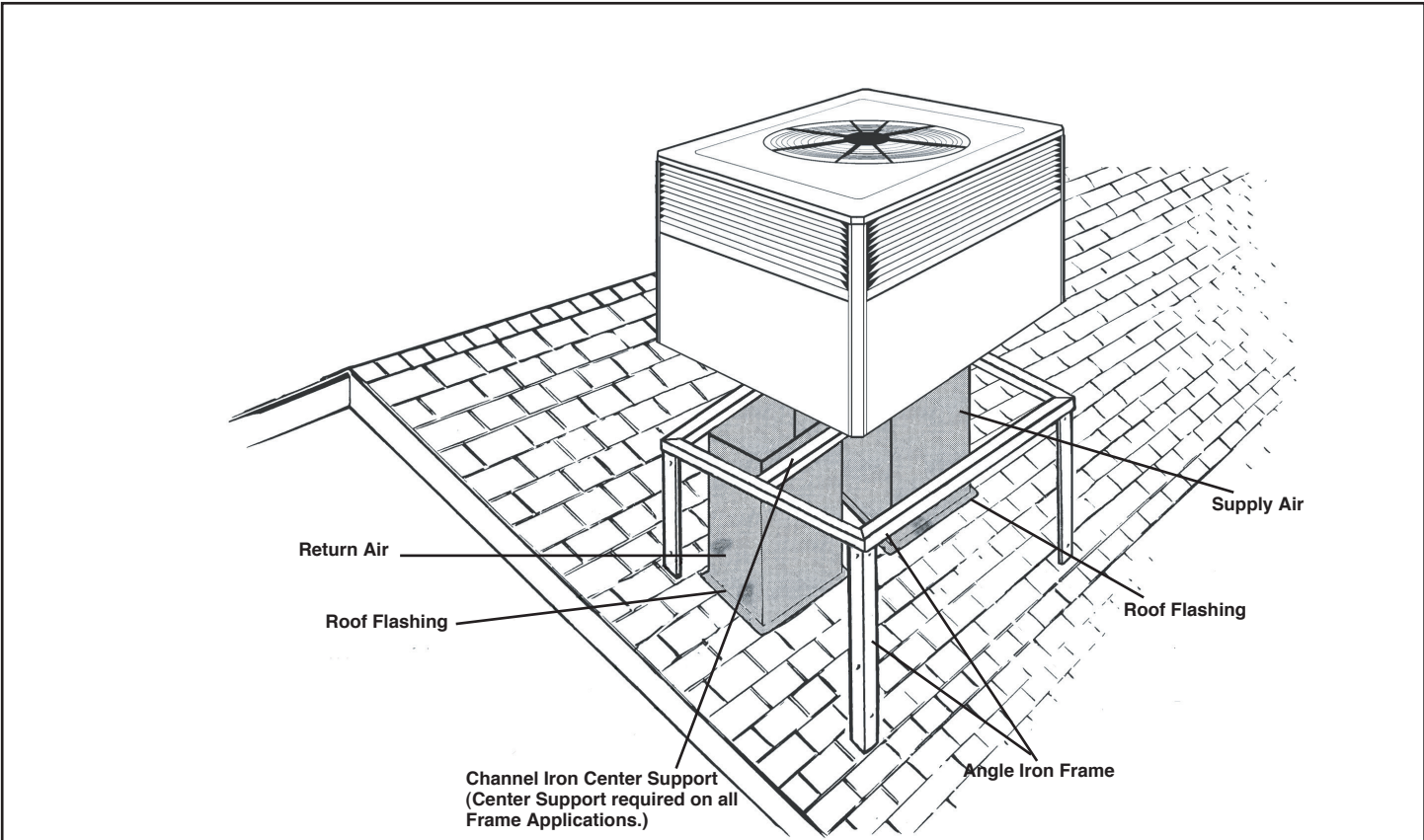
MODEL	A	B	C	D	E	F	G	H	J	K	L
4 TC*, YC*, WC*, DC*018, 024, 030, 036	48-3/8	40-7/8	38-7/8	46-3/8	16	12	6-5/8	6-7/8	12	16	
4 TC*, YC*, WC*, DC*042, 048, 060	58	43-7/8	41-7/8	56	18	15	18	9-5/8	12-1/2		15

This drawing was prepared by the manufacturer in order to provide detail regarding job layout only. This drawing is not intended to be used as a basis to construct, build or modify the item depicted in the drawing. The manufacturer is not responsible for the unauthorized use of this drawing and expressly disclaims any liability for damages resulting from such unauthorized use.

**Figure 11. Curb Dimensions**



**Figure 12. Typical Rooftop Horizontal Airflow Application with Frame**



**Figure 13. Typical Rooftop Down Airflow Application with Frame**

# Installer's Guide

## Ductwork Installation

### Attaching Downflow Ductwork to Roof Curb

Supply and return air flanges are provided on the roof curb for easy duct installation. All ductwork must be run and attached to the curb before the unit is set into place. Refer to the Roof Mounting Curb Installer's Guide for details.

### Attaching Downflow Ductwork to Roof Frame

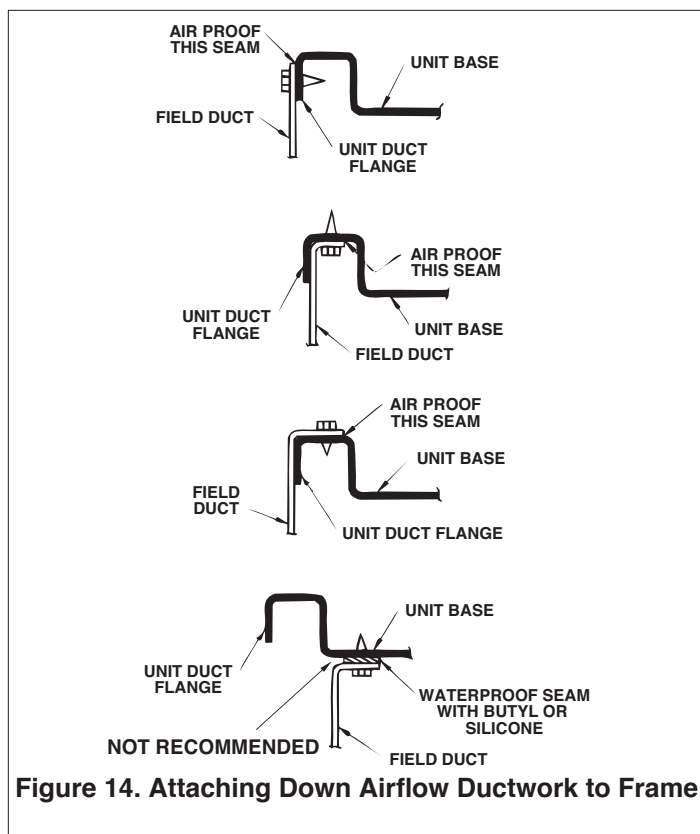
Follow these guidelines for ductwork construction:

Connections to the unit should be made with three-inch canvas connectors to minimize noise and vibration transmission.

Elbows with turning vanes or splitters are recommended to minimize air noise and resistance.

The first elbow in the ductwork leaving the unit should be no closer than two (2) feet from the unit, to minimize noise and resistance.

To prevent leaking, do not attach the ductwork to the bottom of the unit base as the bottom example in Figure 14, below shows.



### Attaching Horizontal Ductwork to Unit

All conditioned air ductwork should be insulated to minimize heating and cooling duct losses. Use a minimum of two (2) inches of insulation with a vapor barrier. The outside ductwork must be weatherproofed between the unit and the building. See Figure 15.

When attaching ductwork to a horizontal unit, provide a flexible watertight connection to prevent noise transmission from the unit to the ducts. The flexible connection **must** be indoors and made out of heavy canvas.

*NOTE: Do not draw the canvas taut between the solid ducts.*

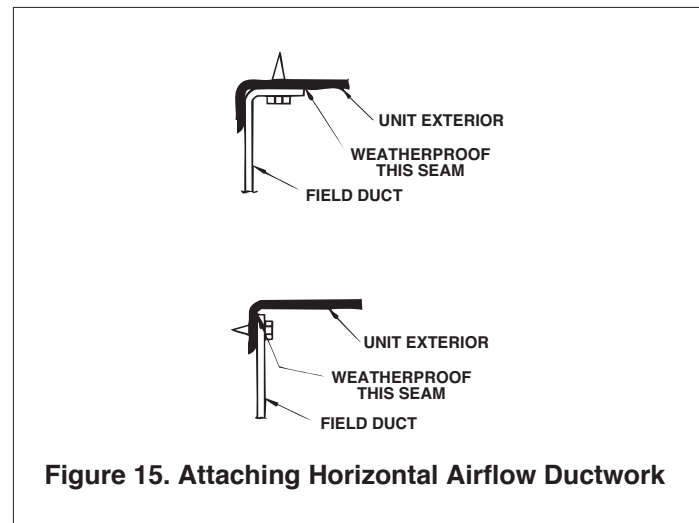


Figure 15. Attaching Horizontal Airflow Ductwork

## Condensate Drain Piping

A 3/4-inch female NPT condensate drain connection is provided on the evaporator access panel end of the unit. Provide a trap and fill it with water before starting the unit to avoid air from being drawn through. Follow local codes and standard piping practices when running the drain line. Pitch the line downward away from the unit. Avoid long horizontal runs. See Figure 16, below.

*NOTE: Do not use reducing fittings in the drain lines.*

The condensate drain must be:

- Made of 3/4" pipe size.
- Pitched 1/4" per foot to provide free drainage to convenient drain system.
- Trapped.
- Must not be connected to a closed drain system unless the trap is properly vented.

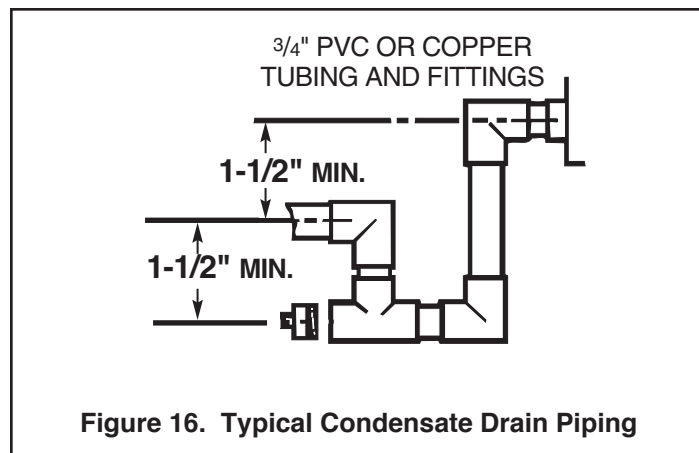


Figure 16. Typical Condensate Drain Piping

## Air Filter Installation

The packaged unit requires an air filter. The unit does not come with a factory installed filter rack in it, however, two filter frame accessories are offered that will allow the installation of a filter within the unit, BAYFLTR101 & BAYFLTR201. Otherwise a field supplied filter rack must be installed by the installer in the return duct work. Refer to Table 1 to determine filter sizes for field supplied filter racks.



**Table 1. Filter Sizes (field supplied filter rack)**

UNIT	NOMINAL CFM	FILTER SIZE(Sq Ft)	FILTER RESISTANCE ("W.C.)
4*CY4024	800	2.67	0.08
4*CY4030	1000	3.33	0.08
4*CY4036	1200	4	0.08
4*CY4042	1400	4.67	0.08
4*CY4048	1600	5.33	0.08
4*CY4060	2000	6.67	0.08

\*Filters must be installed in the return air system. The above square footages are based on 300 F.P.M. face velocity. If permanent filters are used, size per mfg. Recommendation with clear resistance of 0.05"W.C.

## Electrical Wiring

*Note: This unit is factory wired for 230V. See wiring diagram for 208V conversion.*

## Electrical Connections

Electrical wiring and grounding must be installed in accordance with local codes or, in the absence of local codes, with the National Electrical Code ANSI/NFPA 70, Latest Revision.

### Electrical Power

It is important that proper electrical power be available for the unit. Voltage variation should remain within the limits stamped on the unit nameplate.

### Disconnect Switch

Provide an approved weatherproof disconnect within close proximity and **within sight of the unit**. If disconnect must be mounted to the cabinet, the location shown in Figure 19 should be the only one considered.

### Over Current Protection

The branch circuit feeding the unit must be protected as shown on the unit's rating plate.

### Power Wiring

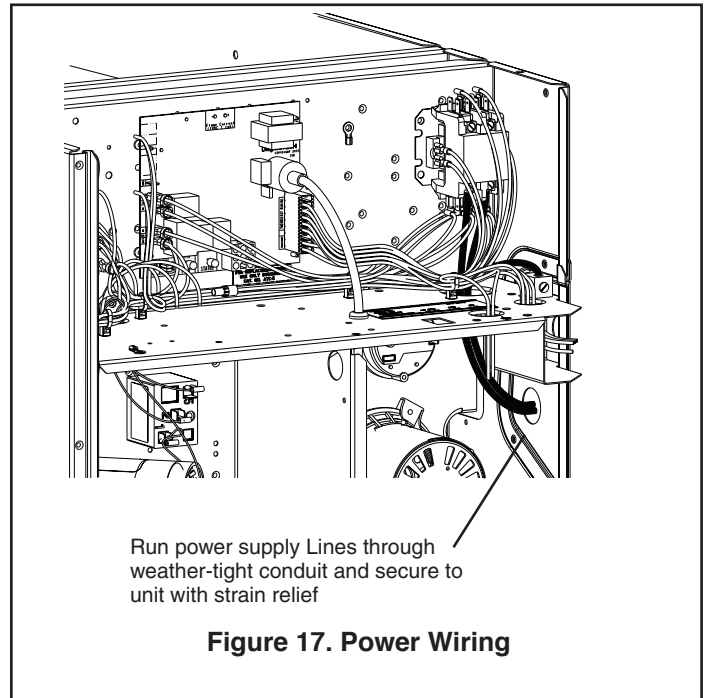
The power supply lines must be run in weather-tight conduit to the disconnect and into the side of the unit control box. Provide strain relief for all conduit with suitable connectors.

Provide flexible conduit supports whenever vibration transmission may cause a noise problem within the building structure.

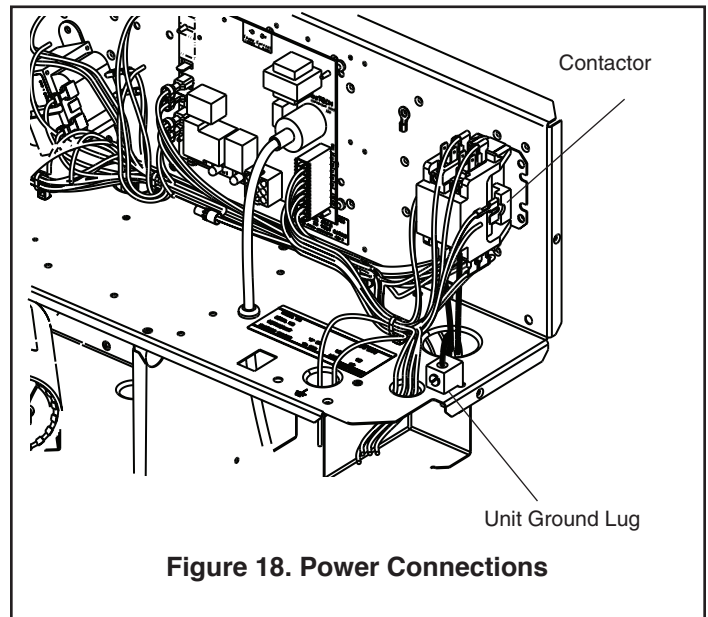
1. Remove the Control/Heat access panel. Pass the power wires through the Power Entry hole in the end of the unit. See Figure 17.
2. Connect the high voltage wires to the appropriate contactor terminals. Single phase units use a two (2) pole contactor and three phase units use three (3) pole contactor. Connect the ground to the ground lug on the chassis. See Figure 19.

Be sure all connections are tight.

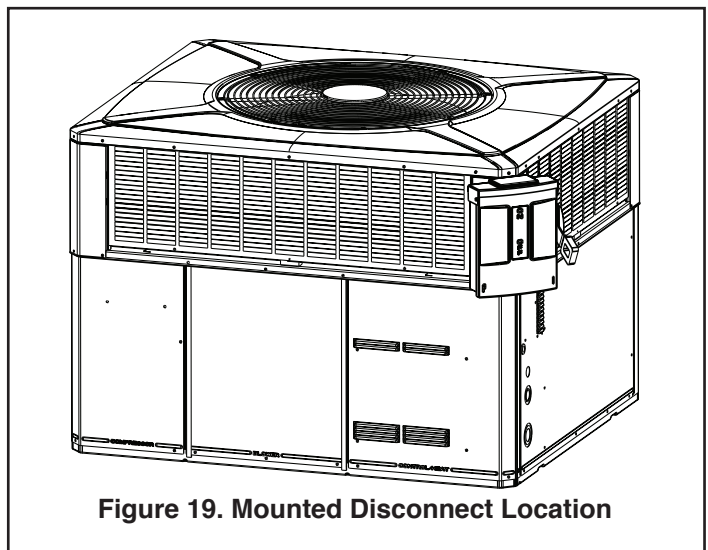
**GROUNDING: THE UNIT MUST BE ELECTRICALLY GROUNDED IN ACCORDANCE WITH LOCAL CODES OR THE NATIONAL ELECTRIC CODE.**



**Figure 17. Power Wiring**

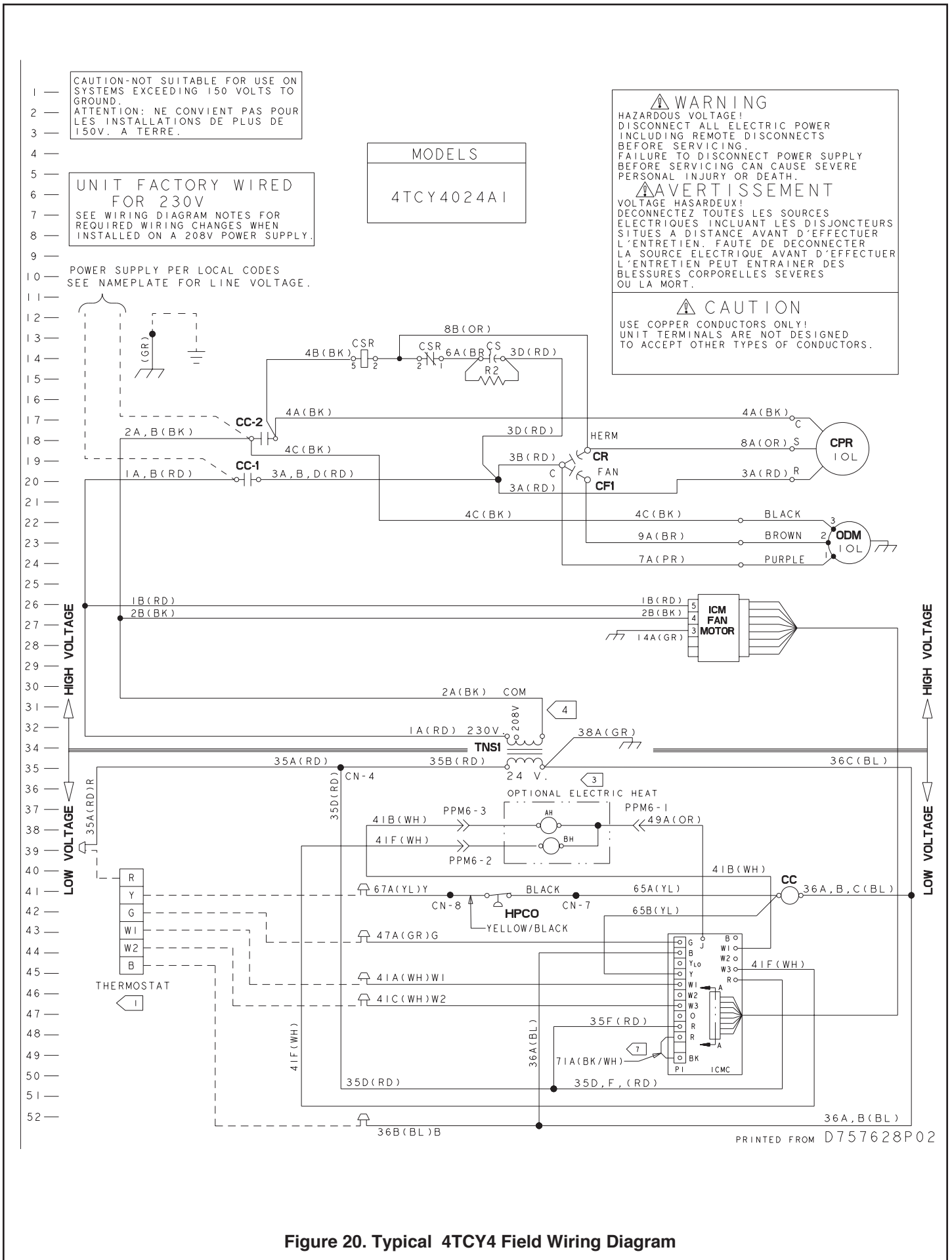


**Figure 18. Power Connections**



**Figure 19. Mounted Disconnect Location**

# Installer's Guide



1 — CAUTION-NOT SUITABLE FOR USE ON SYSTEMS EXCEEDING 150 VOLTS TO GROUND.  
 2 — ATTENTION: NE CONVIENT PAS POUR LES INSTALLATIONS DE PLUS DE 150V. A TERRE.

6 — UNIT FACTORY WIRED FOR 230V  
 7 — SEE WIRING DIAGRAM NOTES FOR REQUIRED WIRING CHANGES WHEN INSTALLED ON A 208V POWER SUPPLY.

MODELS  
 4TCY4024A1

**WARNING**  
 HAZARDOUS VOLTAGE!  
 DISCONNECT ALL ELECTRIC POWER INCLUDING REMOTE DISCONNECTS BEFORE SERVICING.  
 FAILURE TO DISCONNECT POWER SUPPLY BEFORE SERVICING CAN CAUSE SEVERE PERSONAL INJURY OR DEATH.

**AVERTISSEMENT**  
 VOLTAGE HASARDEUX!  
 DECONNECTEZ TOUTES LES SOURCES ELECTRIQUES INCLUANT LES DISJONCTEURS SITUES A DISTANCE AVANT D'EFFECTUER L'ENTRETIEN. FAUTE DE DECONNECTER LA SOURCE ELECTRIQUE AVANT D'EFFECTUER L'ENTRETIEN PEUT ENTRAINDER DES BLESSURES CORPORELLES SEVERES OU LA MORT.

**CAUTION**  
 USE COPPER CONDUCTORS ONLY!  
 UNIT TERMINALS ARE NOT DESIGNED TO ACCEPT OTHER TYPES OF CONDUCTORS.

POWER SUPPLY PER LOCAL CODES  
 SEE NAMEPLATE FOR LINE VOLTAGE.

HIGH VOLTAGE  
 LOW VOLTAGE

HIGH VOLTAGE  
 LOW VOLTAGE

PRINTED FROM D757628P02

Figure 20. Typical 4TCY4 Field Wiring Diagram

## Control Wiring (Class II)

Low voltage control wiring should not be run in conduit with power wiring unless Class 1 wire of proper voltage rating is used. Route the thermostat cable or equivalent single leads of No. 18 AWG colored wire from the thermostat subbase terminals through the rubber grommet on the unit. See Figures 2, 4, 6, or 8 for the control entry (24V Entry) location. Make connections as shown on the unit wiring diagram.

Do not short thermostat wires since this will damage the control transformer.

Refer to Table 2 for recommended wire sizes and lengths for installing the unit thermostat. The total resistance of these low voltage wires must not exceed one (1) ohm. Any resistance in excess of 1 ohm may cause the control to malfunction because of the excessive voltage drop.

**Table 2. Thermostat Wire Size and Maximum Length**

WIRE SIZE	MAXIMUM LENGTH (Ft)
18	75
16	125
14	200

**IMPORTANT:** Upon completion of wiring, check all electrical connections, including factory wiring within the unit.

Make sure all connections are tight. Replace and secure all electrical box covers and access panels before leaving the unit or turning on the power to the unit.

## Thermostat Heat Anticipator

Set the thermostat heat anticipators to equal the amperage draw of the W1 thermostat circuit.

## Step 5—Unit Startup

### Pre-Start Quick Checklist

- Is the unit properly located and level with the proper clearance? See Figures 1 to 6. See Step 3-Review Location and Recommendation Information on page 10.
- Is the duct work correctly sized, run, taped, insulated, and weatherproofed with proper unit arrangement? See Ductwork Installation section on page 16.
- Is the condensate line properly sized, run, trapped, and pitched? See Condensate Drain Piping section on page 16.
- Is the filter of the correct size and quantity? Is it clean and in place? See Air Filter Installation section on page 16.
- Is the wiring properly sized and run according to the unit wiring diagram? See Electrical Wiring section on page 17.
- Are all the wiring connections, including those in the unit, tight? See Electrical Wiring section on page 17.
- Has the unit been properly grounded and fused with the recommended fuse size? See Electrical Wiring section on page 17.
- Is the thermostat well located, level, and correctly wired? See Electrical Wiring section on page 17.
- Have the air conditioning systems been checked at the service ports for charge and leak tested if necessary?

- Do the condenser fan and indoor blower turn free without rubbing, and are they tight on the shafts?
- Has all work been done in accordance with applicable local and national codes?
- Are all covers and access panels in place to prevent air loss and safety hazards?

## Starting the Unit in Cooling Mode

### ⚠ WARNING

Safety Hazard. Do not operate the unit without the evaporator fan access panel or evaporator coil access panel in place. Reinstall the access panels after performing maintenance procedures on the fan. Operating the unit without the access panels properly installed may result in severe personal injury or death.

### ⚠ CAUTION

Before starting the system on the cooling cycle, turn the comfort control to **OFF** and close the unit disconnect switch. This is a precaution against foaming at startup which could damage the compressor bearings.

*NOTE: See the section on "Sequence of Operation" for a description of the cooling operating sequence.*

To start the unit in the cooling mode, set the comfort control to **COOL** and to a setting below room temperature. The condenser fan motor, compressor and evaporator fan motor will operate automatically.

## Operating Pressure Checks

After the unit has operated in the cooling mode for a short period of time, install pressure gauges on the gauge ports of the discharge and suction line valves (behind the Compressor access panel). Check the suction and discharge pressures and compare them to the normal operating pressures provided in the unit's *SERVICE FACTS*.

*NOTE: Do not use the PRESSURE CURVES from the unit's SERVICE FACTS to determine the unit refrigerant charge. The correct charge is shown on the unit nameplate. To charge the system accurately, weigh in the charge according to the unit nameplate and check subcooling against the Subcooling Charging Table in the SERVICE FACTS.*

## Voltage Check

With the compressor operating, check the line voltage at the unit (contactor is located behind the Control access panel). The voltage should be within the range shown on the unit nameplate. If low voltage is encountered, check the size and length of the supply line from the main disconnect to the unit. The line may be undersized for the length of the run.

## Cooling Shut Down

Set the comfort control to **OFF** or to a setting above room temperature.

**IMPORTANT:** De-energize the main power disconnect **ONLY** when servicing the unit. Power may be required to keep the heat pump compressor warm and to boil off refrigerant in the compressor.

# Installer's Guide

## Starting the Unit in Heating Mode

*NOTE: See the section on "Sequence of Operation" for a description of the heating operating sequence.*

Check that all grills and registers are open and all unit access panels are closed before start-up.

Set the comfort control above room temperature until achieving a first stage call for heat and set the fan control to **AUTO** or **ON**.

### Heating Shut Down

Set the comfort control to **OFF** or to a setting below room temperature.

## Sequence of Operation

### General

Operation of the system cooling (and optional heating) cycles is controlled by the comfort control. Once the comfort control is set to either **HEAT** or **COOL**, unit operation is automatic. The optional automatic changeover control, when set to **AUTO**, automatically changes to heat or cool with sufficient room temperature change.

The fan can be set to **ON**, causing continuous evaporator (indoor) fan operation or set to **AUTO** causing fan operation to coincide with heating or cooling run cycles. Continuous fan mode during cooling operation may not be appropriate in humid climates. If the indoor air exceeds 60% relative humidity or simply feels uncomfortably humid, it is recommended that the fan only be used in the **AUTO** mode.

### Cooling Mode

With the comfort control set to **COOL** and the fan set to **AUTO**, the compressor contactor (CC) and the indoor fan motor (IDM) are energized.

The energized compressor contactor (CC) completes the circuit to the compressor (CPR) and a secondary circuit to the outdoor fan motor (ODM). If the compressor safety controls are closed, the compressor (CPR) will operate with the outdoor fan motor (ODM). The indoor fan motor (IDM) will operate. The comfort control will continue to cycle the compressor and fans to maintain the desired temperature.

With the fan set to **ON**, the indoor fan motor (IDM) will continue to run regardless of compressor and condenser fan operation.

### Heating Mode

Heating mode uses electric heaters, which are installed separately. Refer to the Supplemental Electric Heaters Installer's Guide for additional information.

On a call for heat, power from the comfort control is received at "W1", which energizes the "AH" contactor coil. The "AH" contactor closes powering the heater, provided all element limits are closed.

If two stages of heat are provided and additional heat is required, the comfort control's second stage "W2" circuit is energized powering the "BH" contactor coil.

*NOTE: The indoor comfort control must be configured to provide a "G" signal to energize the indoor fan relay (F) during the heating mode. The heater control circuit will not be energized unless the indoor fan relay (F) is energized.*

## Final Installation Checklist

- Does the unit run and operate as described in the section on "Sequence of Operation" in response to the room thermostat?
- Are the condenser fan and indoor blower operating correctly with proper rotation and without undue noise?
- Is the compressor operating correctly and has the system been checked with a charging chart?
- Has the voltage and running current been checked to determine if it is within limits?
- Has the thermostat been checked for calibration and the air discharge grilles adjusted to balance the system?
- Has the ductwork been checked for air leaks and condensation?
- Has the furnace manifold pressure been checked and adjusted if necessary?
- Has the heating air temperature rise been checked?
- Has the unit been checked for tubing and sheet metal rattles? Are there any other unusual noises to be checked?
- Are all covers and panels in place and properly fastened?
- Has the owner been instructed on proper operation and maintenance of the unit? Be sure to leave this manual with the owner.

## Maintenance

### Owner Maintenance

Some of the periodic maintenance functions of the unit can be performed by the owner; this includes replacing the disposable or cleaning the permanent air filters, cleaning the unit cabinet, and conducting a general unit inspection on a regular basis.

#### Filters

**When the system is in constant operation**, inspect the filters at least once each month.

If the unit has disposable-type filters, replace them with new filters of the same type and size. **Do not attempt to clean disposable filters.**

Permanent-type filters can be cleaned by washing them with a mild detergent and water. Make sure that the filters are thoroughly dry before reinstalling them in the unit (or duct system).

*NOTE: It may be necessary to replace permanent filters annually if washing fails to clean the filter or if the filter shows signs of deterioration. Be sure to use the same type and size as was originally installed.*

#### Condenser Coil

Be sure to keep all vegetation and debris away from the condenser coil area.

## Service Maintenance

### Cooling Season

To keep the unit operating safely and efficiently, the manufacturer recommends that a qualified service technician check the entire system at least once each year or sooner if needed. The service technician should examine these areas of the unit:

- ☒ filters (for cleaning or replacement)
- ☒ motors and drive system components
- ☒ economizer gaskets (for possible replacement)
- ☒ safety controls (for mechanical cleaning)
- ☒ electrical components and wiring (for possible replacement and connection tightness)
- ☒ condensate drain (for proper sealing and cleaning)
- ☒ unit duct connections (to see that they are physically sound and sealed to the unit casing)
- ☒ unit mounting support (for structural integrity)
- ☒ the unit (for obvious unit deterioration)

### Heating Season

Complete the following unit inspections and service routines described at the beginning of each heating season.

- ☒ Visually inspect the unit to ensure that the airflow required for combustion and condenser coil is not obstructed from the unit.
- ☒ Inspect the control panel wiring to verify that all electrical connections are tight and that the wire insulation is intact

## ECM Fan Motor Adjustments

If the airflow needs to be increased or decreased, see the Airflow Table in the SERVICE FACTS. Information on changing the speed of the blower motor is in the Blower Performance Table. Blower speed changes are made on the ECM Fan Control mounted in the control box. The ECM Fan Control controls the variable speed motor. There is a bank of 8 dip switches, (See Figure 21 below), located on the board. The dip switches work in pairs to match the cooling/heat pump airflow (CFM/TON), Fan off-delay options and electric heat airflow adjustment. The switches appear as shown in the Figure below.

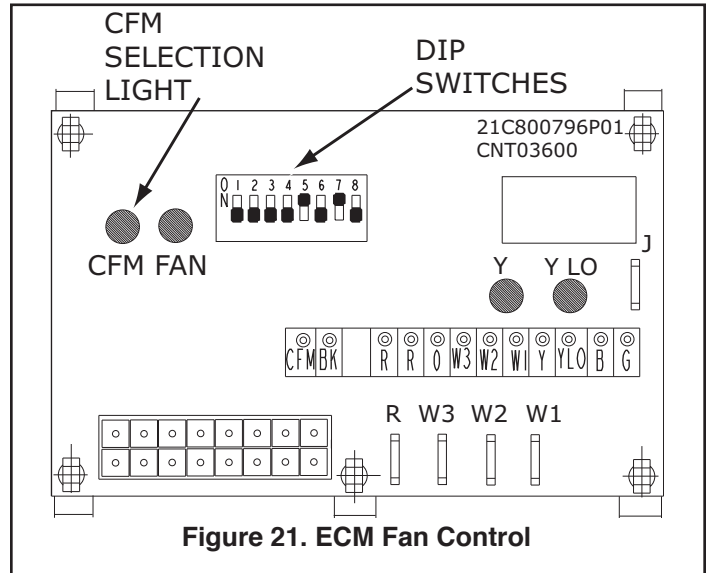


Figure 21. ECM Fan Control

**Notes:**

**Notes:**

## **Important Product Information**

Registering your products helps provide you with one of the strongest manufacturer limited warranties available. To register, go to the manufacturer's website or contact your dealer. You will need the serial number, model number, and installation date for each product being registered. Your dealer may have included these on your invoice or can provide a list for you to use. Please take a few moments to record the following information to ensure your product registration process is quick and easy:

Packaged Unit Serial Number \_\_\_\_\_

Packaged Unit Model Number \_\_\_\_\_

Date of Installation \_\_\_\_\_

Dealer \_\_\_\_\_

### **Service Information**

Call your installing dealer if the unit is inoperative. Before you call, always check the following to be sure service is required:

- a. Be sure the main switch that supplies power to the unit is in the ON position.
- b. Replace any burned-out fuses or reset circuit breakers.
- c. Be sure the thermostat is properly set.

Service Phone \_\_\_\_\_

### About Trane and American Standard Heating and Air Conditioning

Trane and American Standard create comfortable, energy efficient indoor environments for residential applications. For more information, please visit [www.trane.com](http://www.trane.com) or [www.americanstandardair.com](http://www.americanstandardair.com)



The AHRI Certified mark indicates company participation in the AHRI Certification program. For verification of individual certified products, go to [ahridirectory.org](http://ahridirectory.org).

The manufacturer has a policy of continuous data improvement and it reserves the right to change design and specifications without notice. We are committed to using environmentally conscious print practices.

18-EB26D1-16A-EN 01 Jun 2020

Supersedes 18-EB26D1-16-EN (September 2018)

© 2020