

CNT05141

18-CH46D1-2

Two Stage Integrated Furnace Control for Furnaces with Variable Speed Fan INSTALLATION INSTRUCTIONS

Operator: Save these instructions for future use!

**FAILURE TO READ AND FOLLOW ALL INSTRUCTIONS CAREFULLY BEFORE
INSTALLING OR OPERATING THIS CONTROL COULD CAUSE PERSONAL IN-
JURY AND/OR PROPERTY DAMAGE.**

DESCRIPTION

This control is a multi-stage ignition system, based on a solid-state, digital microcomputer. This control is designed for direct burner ignition, starting and timing all system components, operating multi-stage heat and supervision of all gases used in a gas fired furnace equipped with a two speed draft inducer, variable speed indoor blower motor, and discrete pressure switches with a capacity of 150,000 BTU/hr or less. The control has circuitry and software to control a two stage gas valve.

Input to the control is received by way of serial communication or 24 VAC. The control monitors safety inputs from high temperature limit, auxiliary switch(es), temperature sensors, discrete pressure switches, and the flame sensor. The control in turn initiates the starting and precise microcomputer controlled timing of the indoor blower motor, inducer fan motor, ignition means, gas valve, air cleaner, and humidifier. The control provides ignition, proof of ignition via remote sense, internal and external system diagnostics indicators, and dual relays in series with the primary gas valve coil.

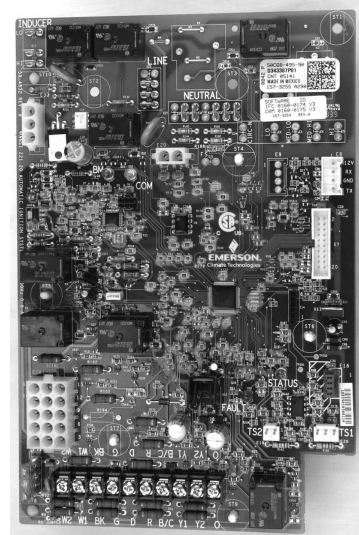

WARNINGS AND CAUTIONS

⚠ CAUTION

Application of this type of control may cause flame rollout on initial startup and could cause personal injury and/or property damage.

Replace only with exact model number, including dash number. Failure to use exact replacement control could cause personal injury and/or property damage.

Do not exceed the specification ratings.
All wiring must conform to local and national electrical codes and ordinances.
This control is a precision instrument, and should be handled carefully. Rough handling or distorting components could cause the control to malfunction.

⚠ CAUTION

To prevent electrical shock and/or equipment damage, disconnect electric power to system at main fuse or circuit breaker box until installation is complete.

This control is not intended for use in locations where it may come in direct contact with water. Suitable protection must be provided to shield the control from exposure to water (dripping, spraying, rain, etc.).

Label all wires prior to disconnection when servicing controls. Wiring errors can cause improper and dangerous operation.

Following installation or replacement, follow appliance manufacturers' recommended installation/service instructions to insure proper operation.

Do not exceed specified voltage of circuits. Higher voltage will damage control and could cause shock or fire hazard.

CONTENTS

Description	1
Warnings and Cautions	1
Specifications	2
Operation.....	3
Installation	8
Wiring	8

⚠ WARNING

Do not short out terminals on gas valve or primary control to test. Short or incorrect wiring will damage the comfort control and could cause personal injury and/or property damage.

SPECIFICATIONS

ELECTRICAL RATINGS [@ 77°F (25°C)]:

Input Voltage: 25 VAC, 60 Hz

Max. Input Current @ 25 VAC: 600mA + MV

Relay Load Ratings:

Gas Valve Relay: 1.5 amp @ 25 VAC, 60 Hz, 0.6 pf

Ignitor: 2.0 amp @ 120 VAC, 60 Hz - resistive

Humidifier Relay: 1.0 Amp @ 120 VAC, 60 Hz.

Electronic Air Cleaner Relay: 1.0 Amp, @ 120 VAC, 60 Hz

Inducer Relays: 2.2 FLA - 3.5 LRA @ 120VAC

Flame Current Requirements:

Minimum current to insure flame detection: 1 µA DC*

Maximum current for non-detection: 0.1 µA DC*

Maximum allowable leakage resistance: 100 M ohms

*Measured with a DC microammeter in the flame probe lead

OPERATING TEMPERATURE RANGE:

-40° to 176°F (-40° to 80°C)

HUMIDITY RANGE:

5% to 95% relative humidity (non-condensing)

Timing Specs: (@ 60 Hz**)

maximum

Flame Establishing Time: 0.8 sec

Flame Failure Response Time: 2.0 sec

Gases Approved: Natural and Liquid Petroleum are approved for use.

Table 1 - TIMING SPECIFICATIONS
(All times are in seconds, unless noted otherwise)

CNT05141

PRE-PURGE	0
TRIAL FOR IGNITION PERIOD	5
IGNITION ACTIVATION PERIOD	2
RETRIES	2 times
VALVE SEQUENCE PERIOD	15
INTERPURGE	60
POST-PURGE	5
LOCKOUT TIME	300
HEAT DELAY-TO-FAN ON	45
HEAT DELAY-TO-FAN OFF*	60/100/ 140/180
COOL DELAY-TO-FAN OFF*	**
ELECTRONIC AIR CLEANER	YES
HUMIDIFIER	YES

*These times will vary depending on option switch position.
See OPERATION section for further information.

**Selectable at Comfort Control

OPERATION

USER INTERFACE

The User Interface is used to adjust system operating parameters. Refer to furnace Service Facts or Installer's Guide for User Interface options.

PERSONALITY MODULE

The Personality Module is a removable device required for proper furnace operation. The Personality Module is tethered to the unit and must remain with the furnace at all times. The Personality Module must remain plugged into the furnace IFC. The Personality Module should be removed from the existing IFC and installed and tethered on the replacement IFC.

COMMUNICATION PROTOCOL (System)

In communicating mode, the operational commands and queries will be sent by the comfort control system to the furnace control via a serial communication bus.

In 24 volt mode, the operational commands will be sent by the comfort control system to the furnace control via the 24VAC output.

The control includes an amber LED to indicate communications on the communicating control bus and a green LED to indicate Bit Master operation. The amber LED on the communicating control indicates communications are present on the bus. The green LED indicates Bit Master operation. See Table 2.

COOLING MODE

Air Conditioning or Cooling Mode airflow shall be calculated based on the Outdoor (OD) Unit Capacity (Tons), CFM per Ton input from the Personality Module, User Interface, and Aux Circ Request. When used in an all communicating system, the comfort control will determine all delays in this mode. When used in an all 24 VAC systems, see the 24 volt user interface options to set cooling tonnage, cfm/ton, and delays. See Comfort Control Installer's Guide for more information.

When a communicating OD unit is not detected, the OD unit size will be selectable from the User Interface.

MANUAL FAN ON MODE

If the comfort control fan button is placed to the ON position, the indoor blower and air cleaner are energized. When the fan button is returned to the AUTO position, the indoor blower and air cleaner are de-energized.

COOL MODE

A call for cool is sent by the comfort control. This energizes the compressor, indoor blower and air cleaner. After the comfort control is satisfied, the compressor is de-energized and the optional cool mode delay-to-fan-off period begins. After the optional delay-to-fan-off period ends, the indoor blower and air cleaner are de-energized.

CONTINGENCY MODE

The Contingency Mode allows the user to set the equipment to operate in an on/off, duty cycle mode. This mode will be activated using the User interface. The user will select the desired level of capacity required, Stage 1 or 2. The user will select the desired on/off duty cycle, 10% minimum to 50% maximum, (10% increments, 10% = 2 minutes On, 18 minutes Off; 50% = 10 minutes on, 10 minutes off).

Contingency Mode is only available if the comfort control is not detected. If setting the unit operation in the Contingency Mode, disconnect the "D" data wire at the low voltage unit terminal block.

An alternative method for the contingency mode can be used by changing the mode of operation in the user interface to 24v mode and installing a conventional 24v comfort control. To set this mode of operation:

Remove all wiring from the *CONT900 comfort control and install a 24v comfort control. If the comfort control requires a 24v common; connect R and B to respective terminals. Connect 3rd wire to "W". At the control board, connect the same 3 wires to the corresponding terminals. Jumper W1 to W2 at the control board. The stage delay between W1 & W2 can be set by scrolling thru the user interface. It is factory set at zero minutes but can be adjusted to 5, 10, or 15 minutes.

See the furnace Service Facts or Installer's Guide for instructions on how to enter the Contingency Mode.

PRECAUTIONARY, SYSTEM LOCKOUT, AND DIAGNOSTIC FEATURES

PRECAUTIONARY FEATURES

The following precautionary features are built into the control.

1. During a call for heat cycle, if flame is sensed at any time when the gas valve is de-energized, the indoor blower and inducer fan are energized at low speed in conjunction with system lockout.
2. If the high limit (and/or auxiliary limit) switch(es) open at any time during a call for heat, the gas valve is de-energized and the indoor blower and inducer fan are energized at low speed.

SYSTEM LOCKOUT FEATURES

When system lockout occurs, the gas valve is de-energized, the indoor blower output and the inducer blower are energized at low speed. The diagnostic indicator light will flash to indicate system status. (System lockout will never override the precautionary features described above.)

To reset the control after system lockout, do one of the following:

1. Open the door switch for at least fifteen seconds. You may also need to reset the flame rollout sensor switch.
2. After one hour in lockout, the control will automatically reset itself.

SEQUENCE OF OPERATION

NOTE:

The numbers in parentheses refer to the numbers along the left side of Figure 2 on page 5.

- The communicating comfort control (17) signals the furnace IFC for first stage heat. (16)
- The IFC then checks all safeties, thermostats (10) & pressure switches PS-1 & 2. (9)
- The IFC signals to start the vent motor (8) and go to its second stage speed.

Note:

The furnace lights in First Stage mode.

- First stage pressure switches PS-1 close. (9)
- The IFC receives a 24 Volt AC signal from pressure switch PS-1 when it closes. (9) This verifies the vent motor is moving the correct amount of combustion air through the furnace and vent system.
- The IFC will then signal the vent motor (8) to go to its first stage speed.
- IFC starts the hot surface igniter learning routine warm up time cycle. (6)
- IFC turns on the gas valve. (11) Trial time for ignition is five seconds.
- The IFC verifies ignition by the flame current sensing method. (7) If a flame is not detected, the IFC will cycle the furnace three times to try and verify a flame. If no flame is detected, the IFC will lock out for one hour. The IFC will send an alert code to the communicating comfort control and user interface (12). The IFC will also flash its Red alert LED two times repeatedly.
- If a flame is detected, the IFC will start the 45 second heat exchanger warm-up time delay for the indoor blower.

- After 45 seconds, the IFC signals the indoor blower (4) to engage and run at its first stage heat speed.
- The communicating comfort control (17) will continue to call for first stage heat operation until the indoor temperature is back at the communicating comfort control set point, OR,
- If the communicating comfort control (17) does not detect that the indoor temperature is moving back towards its set point, it will signal the IFC (16) to go to second stage heat, OR,
- If the communicating comfort control (17) detects that the indoor temperature is still moving away from the communicating comfort control set point, it will signal the IFC (16) to go to second stage heat.
- Second Stage Heat: The IFC signals the vent motor (8) to switch to second stage heat speed.
- When the IFC detects a 24 Volt AC signal that pressure switch #2, PS-2, (9) is closed, the IFC will then signal the indoor blower (4) to go to its second stage heat speed.
- The communicating comfort control (17) will continue to call for second stage heat operation until the indoor temperature approaches its set point. Before the indoor temperature reaches the communicating comfort control (17) set point the communicating comfort control will signal the furnace IFC to go back to first stage operation.
- The communicating comfort control will continue to monitor the indoor temperature and send signals to the IFC to operate at different stages or turn off so that it can maintain the indoor temperature at the homeowner's set point.

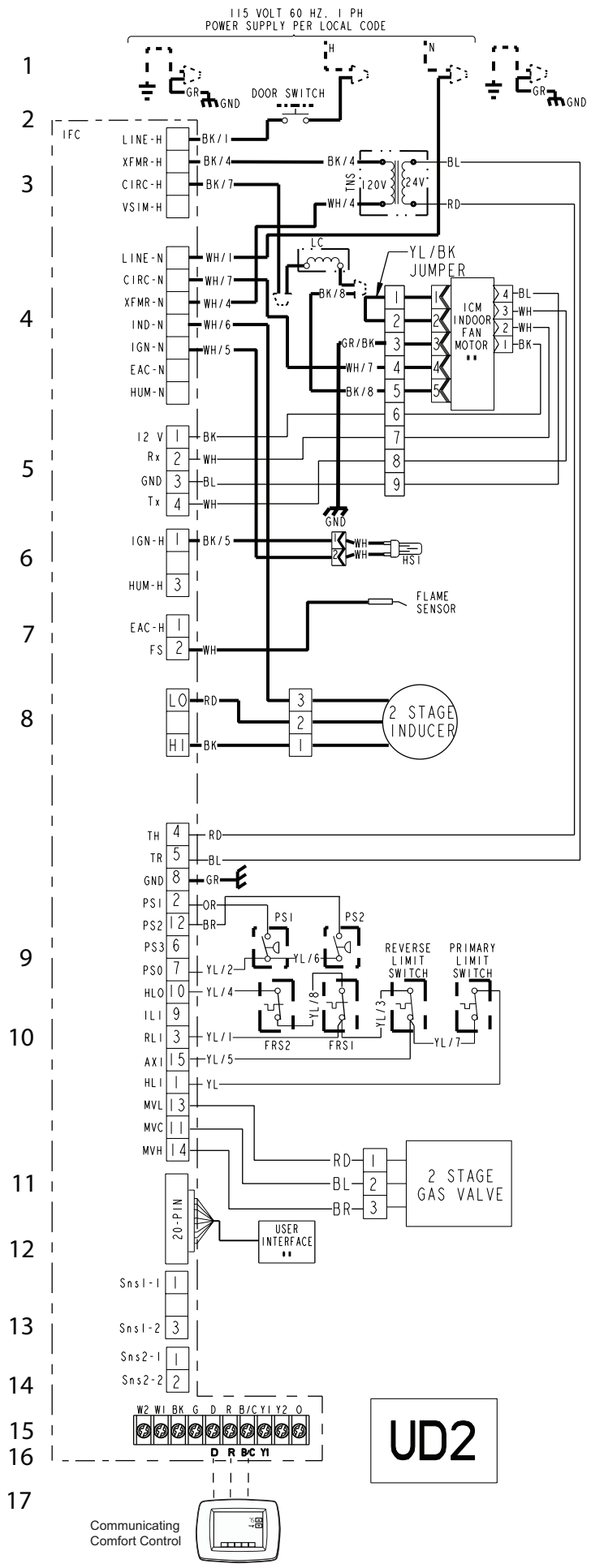

DIAGNOSTIC FEATURES

Diagnostic Operation, LED Flash Codes

The green, 'STATUS', and red LEDs will be turned on solid at power-up during the initialization sequence. At any other time the control is powered, the green LED indicator light shall be lit using the following signal:

Slow Flash Rate: Normal, no call for heat. 1/4 second on, 3/4 second off.

Fast Flash Rate: Normal, call for heat. 1/4 second on, 1/4 second off.

During an alert condition, the red LED will flash groups of pulses. The red LED will flash on for approximately 1/4 second then off for 1/4 second. The pause between groups of flashes is approximately 2 seconds.

Alert Code Recovery: On power up, last 4 Alerts, if any, will be flashed on the Red Alert LED. The newest Alert detected will flash first and the oldest last. There will be a 2 second delay between Alert Code flashes. Solid Red LED error codes will not be displayed in the last four alerts.

The Green BM LED will be on solid when the control is powered. The Green status LED indicator light will operate as shown in the table.

The current Alert(s) are available to display anytime via the user interface, menu item ID Alerts.

The last four alerts will be available to display at any time via the User Interface, menu item Last Four Faults. See the User Interface Software Specification for more information.

Fault Code Reset: The control shall acknowledge the reset by turning on the Red LED and Green 'STATUS' LED for 2 seconds. The alert code may be reset using the User interface.

NOTE:

Use the flash code menu for detail of the alerts. Alert codes also are displayed on the User Interface menu using a descriptive text message and on the comfort control display using an alert code number. A complete list of the alert codes is included with the comfort control.

Table 2 - LED Flash Codes

LED	DESCRIPTION	FUNCTION
GREEN	STATUS LED	FAST FLASH - CALL FOR HEAT SLOW FLASH - NO CALL FOR HEAT
RED	ALERT LED	NO. OF FLASHES - SEE DIAGNOSTIC CODES
GREEN (BM)	BITMASTER	ON SOLID WHEN UNIT POWERED
AMBER	COM	FLASHES DEVICE COUNT

Table 3 - Diagnostic Codes

The diagnostics will indicate the specific alert through the following code:

Red LED Flash	Diagnostic Code
2	External lockout (retries or recycles exceeded)
3	Pressure switch/Inducer error
4	Open limit switch & Aux & Rollout
5	Flame sensed when no flame should be present
6	Reversed polarity, or Igniter (Triac) Fault / Ground fault
7	External gas valve circuit error (voltage sensed when it should not be sensed)
8	Low Flame Sense
10	Communication Error
Solid Red	Internal GV Error (caused by IFC)
Solid Red w/Solid 'Status' LED	Continuous Reset caused by an internal error
Red Off and 'Status' Off	24Vac Fuse Open

Table 4 - FURNACE ALERT CODES

Alert Notification				Alert Code	Alert Group	Alert Description
Fault LED	COM LED	User Interface Display	Control Display			
2 Flash	Device count	RECYCLE	N/A	20	Flame lost or Ignition failure	Flame is off when flame should be detected. Furnace tries to relight itself.
		RETRY				Furnace tries to light, but no flame is detected.
		RECYCLE LO	ERR 22	22	Soft lockout due to flame lost or ignition retries	10 recycles within a single call for heat will cause 1hr lockout.
		RETRY LO				3 ignition attempts in a row within a single call for heat results in 1 hr lockout.
3 Flash	Device count	PS2 OPEN	N/A	1	Pressure Switch Failure	Open Pressure Switch, second stage
		PS2 CLOSED				Shorted Pressure Switch, second
		PS1 OPEN				Open Pressure Switch, first stage
		PS1 CLOSED				Shorted Pressure Switch, first stage
4 Flash	Device count	AUX LIMIT	ERR 26	26	High Temp Limit Fault	Open Reverse Flow - Heat exchanger temperature too high. Could be caused by low airflow or fan failure.
		HIGH LIMIT				Open High Limit - Heat exchanger temperature too high. Could be caused by low airflow or fan failure.
		ROLLOUT OPEN	ERR 87	87	Roll Out Fault	Open flame rollout
5 Flash	Device count	FLAME ERROR	ERR 34	34	Flame Detect Fault	Flame detected, should not be present
6 Flash	Device count	POLARITY ERR	N/A	33	Line Polarity Fault	Voltage reverse polarity
		GND FAULT	N/A	88	Ground Fault	Occurs when proper earth ground is not detected.
		IGNITER ERR	ERR 10	10	Ignition Means Fault	Igniter fault
		TRIAC ERR				Triac fault
7 Flash	Device count	EXT GV ERR	ERR 93	93	Gas Valve Fault	Control senses 24V present at the gas valve when it should not be present.
Solid ON		INT GV ERR				Control senses 24V present at the gas valve when it should not be present.
8 Flash	Device count	LO FLAME SNS	N/A	4	Low Flame Signal	Flame current is low, but still strong enough to allow operation.
10 Flash	Device count	SYS COMM CRC	N/A	90	Communication Busy Fault	COMM system unrecognized response
		IND COMM CRC				Inducer Motor unrecognized response
		BLW COMM CRC				Blower motor unrecognized response
	Device count	BLW COMM ERR	ERR 91	91	Communication Fault	Blower motor no COMM response ¹
	IND COMM ERR	Inducer motor no COMM response				
	Fast Flash	SYS COMM ERR #REF!				Loss of heat/cool demand #REF!
	Device count	24V COMM MSMTCH	ERR 139	139	Communication Failure	Communication Message has been detected while configured for 24V Mode
Solid ON	Device count	CNTRL FAULT	ERR 18	18	Control Failure	Internal control failure
None	Device count	TWIN ERROR	N/A	19	Twinning Fault	Twinning Not Allowed with Variable Speed
None	Device count	PM DATA ERR	N/A	114	Bad or Missing PM	Data Section is Corrupt but PM is useable
		CAP MISMATCH				Compressor size does not match capacity in PM
		ID MTR ERR	ERR 114			Blower HP/OEM does not match PM Data
		PM MISSING				No PM
		PM UNIT ERR	N/A			Primary Copy of Unit Data File is Corrupt.
		PM MEM ERROR	ERR 114			Primary and Secondary copies of Unit Data File are Corrupt
None	Device count	AC VOLTS LOW	N/A	59	AC Line Fault	Voltage too low
		AC VOLTS HI				Voltage too high
None	Device count	CHECK FUSE	N/A	92	Fuse	24V Fuse Open
None	Device count	Y1 OFF ERR	ERR 101	101	Y1 Relay Failure	Y1 Output OFF when it should be ON
		Y1 ON ERR				Y1 Output ON when it should be OFF
None	Device count	TS 1 SHORT	N/A	119	Temperature Sensor Failure	Temperature sensor 1 shorted.
		TS 1 OPEN				Temperature sensor 1 open.
		TS 2 SHORT				Temperature sensor 2 shorted.
		TS 2 OPEN				Temperature sensor 2 open.
Notes:		¹ Comfort Control will switch system to "OFF" until this fault condition clears				
D342960P02		PRINTED FROM: D802247P01 Rev 10				

INSTALLATION

WIRING

WARNING

Do not use on circuits exceeding specified voltage. Higher voltage will damage control and could cause shock or fire hazard.

CAUTION

To prevent electrical shock and/or equipment damage, disconnect electric power to system at main fuse or circuit breaker box until installation is complete. Failure to earth ground the appliance or reversing the neutral and hot wire connection to the line can cause shock hazard.

Shut off main gas to heating system until installation is complete.

Route and secure all wiring as far from flame as practical to prevent fire and/or equipment damage.

Replace CNT05141 control as a unit - no user serviceable parts.

NOTE:

All wiring should be installed according to local and national electrical codes and ordinances.

Following installation or replacement, follow appliance manufacturer's recommended installation or service instructions to insure proper operation.

Removing the old IFC and installing the new IFC:

- 1) Remove all power from the system.
- 2) Label and remove wires at low voltage terminal block.
- 3) Remove the User Interface and bracket from the front of the IFC. To remove these items, remove the pins in the center of the fasteners on the side of the bracket that attach to the IFC platform. Rotate the bracket and User Interface assembly downward. Squeeze the back pieces of the fasteners together to remove the fasteners.
- 4) Remove all wiring connected to the IFC with modular plugs.
- 5) Remove Personality Module from IFC.
- 6) Remove the IFC.
 - Upflow - Remove the two screws located on the bottom of the blower deck using a 5/16" nut driver. Slide the IFC platform towards the front of the unit until the back tabs disengage from the blower deck. Cut the plastic standoffs on the back of the platform.
 - Downflow - Holding the IFC platform, remove the three screws on the top of the furnace top panel using a 5/16" nut driver. Cut the plastic standoffs on the back of the platform.
- 7) Place new IFC on platform using standoffs on new IFC.
- 8) Reconnect the low voltage wires at terminal block.
- 9) Plug Personality Module onto IFC. The Personality Module must be plugged into the IFC at all times during unit operation.
- 10) Reconnect all wiring with modular plugs.
- 11) Remount the IFC platform using prior steps in reverse order.
- 12) Remount User Interface using the fasteners removed in step 2.
- 13) Restore power to the unit.
- 14) Use the User Interface to establish any custom set-up parameters.
- 15) Run system through operational check.

COMMUNICATING OUTDOOR UNIT

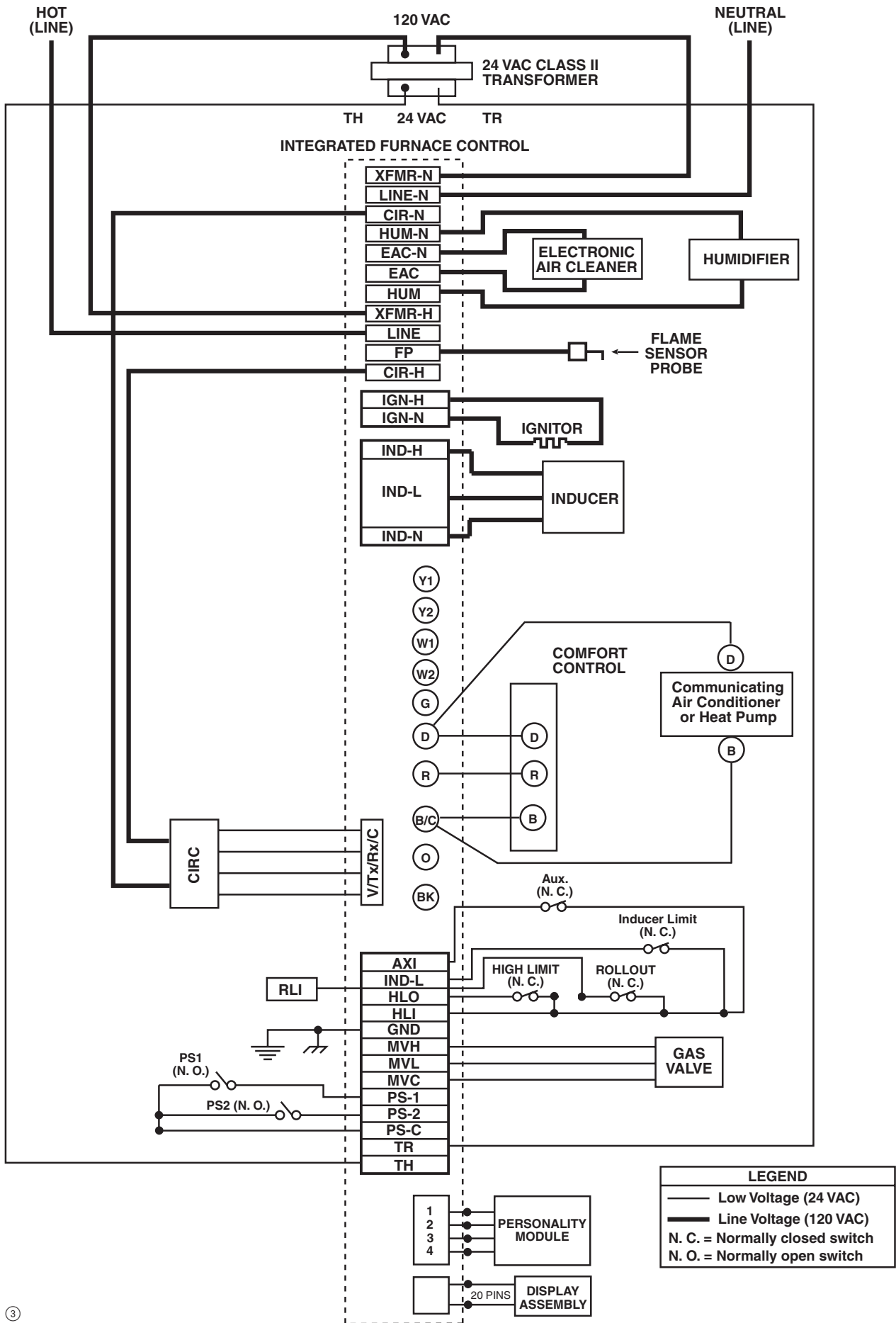

LEGEND	
	Low Voltage (24 VAC)
	Line Voltage (120 VAC)
	N. C. = Normally closed switch
	N. O. = Normally open switch

24V SINGLE / MULTI-STAGE COOLING / HEATPUMP

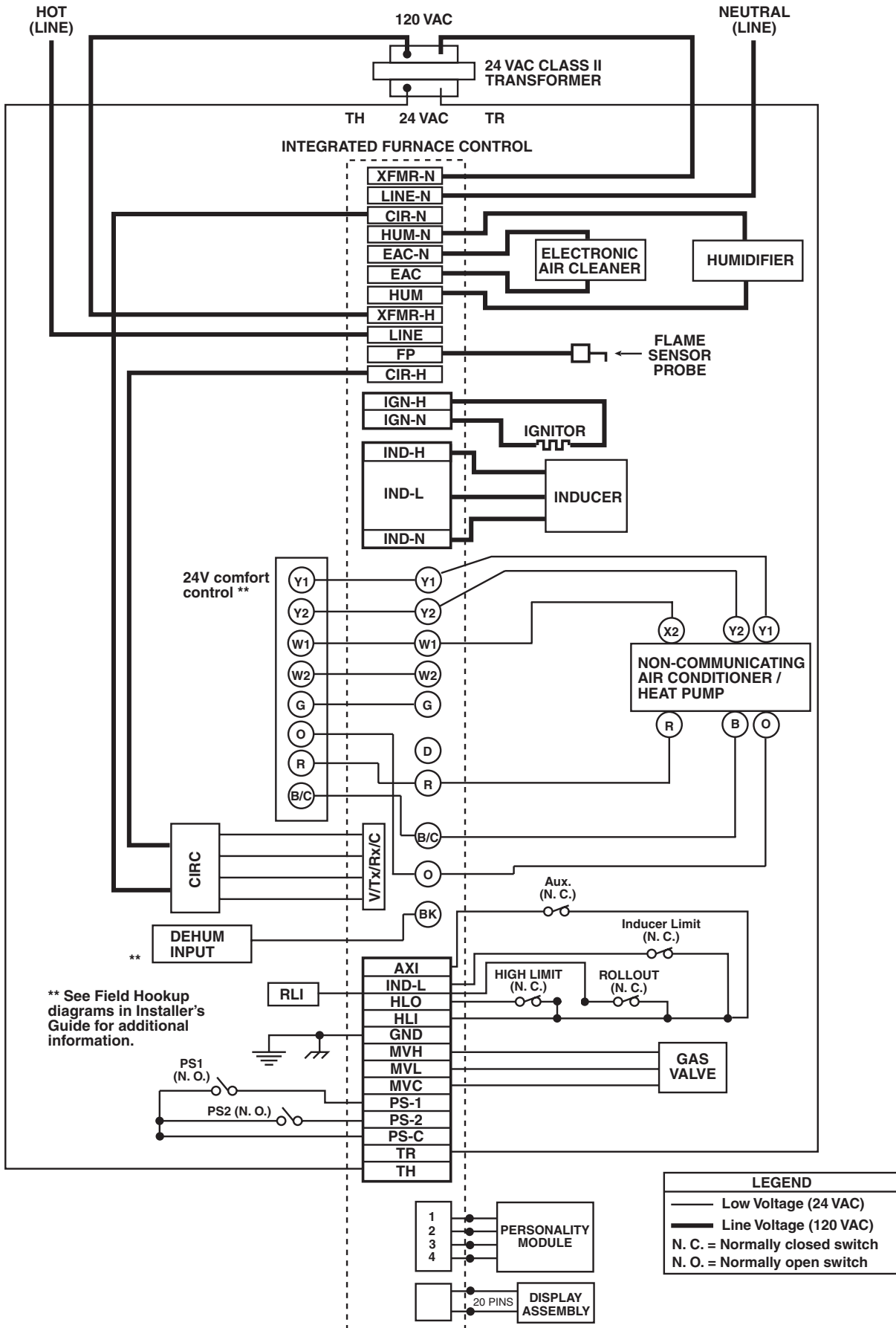

** See Field Hookup diagrams in Installer's Guide for additional information.

NON-COMMUNICATING SINGLE STAGE COOLING ONLY OUTDOOR UNIT

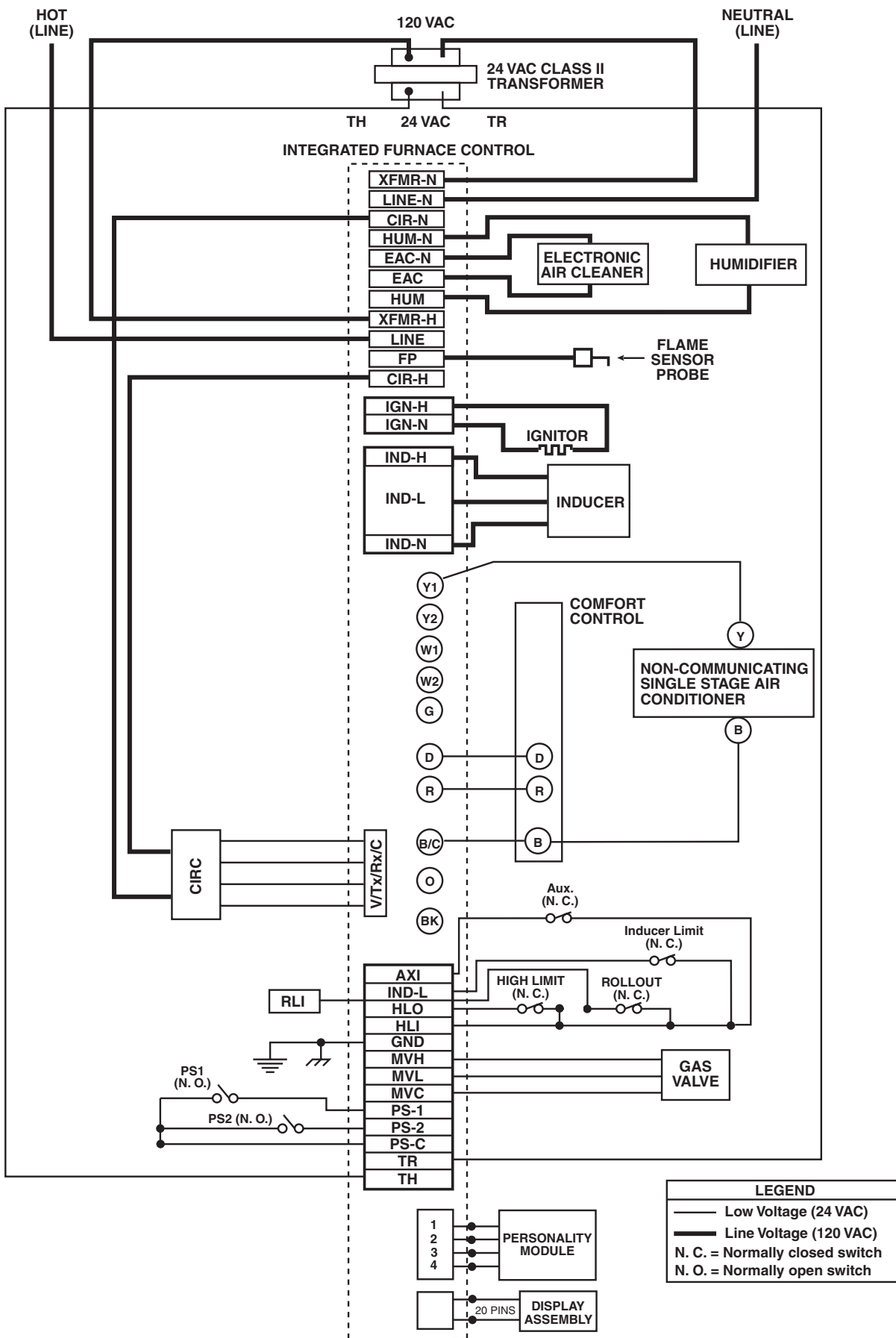

5

TYPICAL SYSTEM WIRING CONNECTIONS

Low voltage screw terminal block

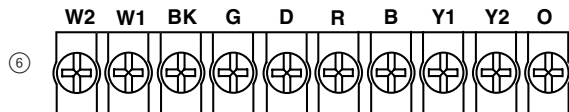

- W2 Two stage comfort control W2 terminal (or equivalent)
- W1 Two stage comfort control W1 terminal (or equivalent)
- BK Humidistat enable output to circulator
- G Two stage comfort control G terminal (or equivalent)
- D serial communication bus (comfort control)
- R 24VAC (fused)
- B 24V common
- Y1 24VAC relay output for single stage, non-communicating air conditioners OR two stage comfort control Y_{Lo} terminal (or equivalent)
- Y2 Two stage comfort control Y terminal (or equivalent)
- O H/P or cooling mode output to circulator

15 pin connector

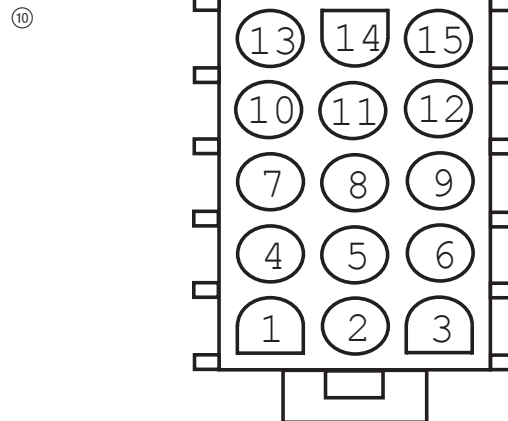

Igniter Interface

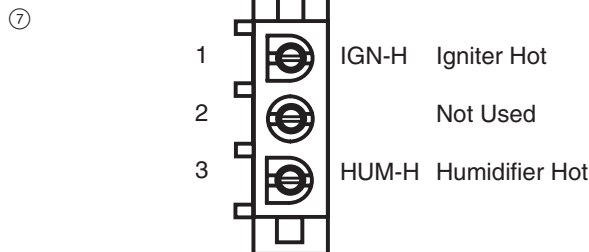

- Pin 1 - HLI Limit Switch Input
- Pin 2 - PS1 First Stage Pressure Switch Input
- Pin 3 - RLI Rollout Input
- Pin 4 - TH High Side of secondary of Transformer, 24VAC un-fused
- Pin 5 - TR 24VAC common, connected to GND
- Pin 6 - - Not Used
- Pin 7 - PSO R out to the Pressure Switches
- Pin 8 - GND connected to chassis and earth ground
- Pin 9 - - Not Used
- Pin 10 - HLO R out to the Limit Switches
- Pin 11 - MVC Gas Valve Common
- Pin 12 - PS2 Second Stage Pressure Switch Input
- Pin 13 - MVL Gas Valve Main Low
- Pin 14 - MVH Gas Valve Main High
- Pin 15 - AXI Reverse Flow Input

Line Voltage Terminals (0.25" x 0.032")

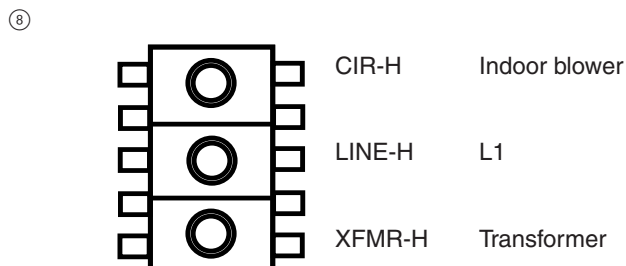

Neutrals (0.25" x 0.032")

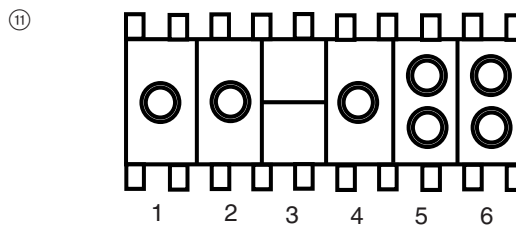

Accessory Line Voltage Terminals

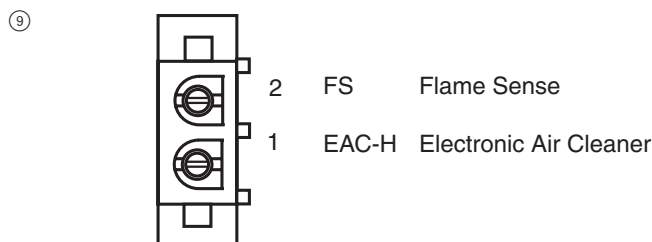

- 1 CIRC-N Indoor blower
- 2 LINE-N L2
- 3 Not Used
- 4 XFMR-N Transformer
- 5 EAC-N Electronic Air Cleaner
- 5 IGN-N Ignitor
- 6 IND-N Inducer
- 6 HUM-N Humidifier