

Installation instructions for KIT15017, KIT15018, KIT15019, and KIT15020

⚠ WARNING: HAZARDOUS VOLTAGE - DISCONNECT POWER BEFORE SERVICING

ALL phases of this installation must comply with NATIONAL, STATE AND LOCAL CODES

IMPORTANT — This Document is **customer property** and is to remain with this unit. Please return to service information pack upon completion of work.

Applications

Kits are used to upgrade from the ECM inducer (BLW00732) to the 3-phase inducer (BLW00879) and IFC with integral variable speed motor control (CNT04984 or CNT04985). These kits take the place of the BLW00732 replacement part, which is no longer available.

KIT15017 is used to upgrade model families *UY-R-V0, V1, V2, V3, W0, W1, W2, and W3.

KIT15018 is used to upgrade model families *DY-R-V0, V1, V2, V3, W0, W1, W2, and W3.

KIT15019 is used to upgrade model families *UX-R-V0, V1, V2, V3, W0, W1, W2, and W3.

KIT15020 is used to upgrade model families *DX-R-V0, V1, V2, V3, W0, W1, W2, and W3.

* May be "A" or "T"

Safety Section

Safety signal words are used to designate a degree or level of seriousness associated with a particular hazard. The signal words for safety markings are **WARNING**, and **CAUTION**.

- WARNING** indicates a potentially hazardous situation which, if not avoided, could result in death or serious personal injury.
- CAUTION** indicates a potentially hazardous situation which, if not avoided, may result in minor or moderate injury. It is also used to alert against unsafe practices and hazards involving only property damage.

⚠ WARNING

SAFETY HAZARD
THIS INFORMATION IS INTENDED FOR USE BY INDIVIDUALS POSSESSING ADEQUATE BACKGROUNDS OF ELECTRICAL AND MECHANICAL EXPERIENCE. ANY ATTEMPT TO REPAIR A CENTRAL AIR CONDITIONING PRODUCT MAY RESULT IN PERSONAL INJURY AND OR PROPERTY DAMAGE. THE MANUFACTURER OR SELLER CANNOT BE RESPONSIBLE FOR THE INTERPRETATION OF THIS INFORMATION, NOR CAN IT ASSUME ANY LIABILITY IN CONNECTION WITH ITS USE.

⚠ WARNING

FIRE OR EXPLOSION HAZARD
FAILURE TO FOLLOW THE SAFETY WARNINGS EXACTLY COULD RESULT IN SERIOUS INJURY, DEATH OR PROPERTY DAMAGE.
IMPROPER SERVICING COULD RESULT IN DANGEROUS OPERATION, SERIOUS INJURY, DEATH, OR PROPERTY DAMAGE.

⚠ CAUTION

The IFC is polarity sensitive. The hot leg of the 115 VAC power must be connected to the BLACK field lead.

⚠ WARNING

THE CABINET MUST HAVE AN UNINTERRUPTED OR UNBROKEN GROUND ACCORDING TO NATIONAL ELECTRICAL CODE, ANSI/NFPA 70 - "LATEST EDITION" AND CANADIAN ELECTRICAL CODE C22.1 OR LOCAL CODES TO MINIMIZE PERSONAL INJURY IF AN ELECTRICAL FAULT SHOULD OCCUR. FAILURE TO FOLLOW THIS WARNING COULD RESULT IN SERIOUS PERSONAL INJURY, PROPERTY DAMAGE, OR DEATH.

⚠ WARNING

ELECTRIC SHOCK HAZARD
DISCONNECT POWER TO THE UNIT BEFORE REMOVING THE BLOWER DOOR. ALLOW A MINIMUM OF 10 SECONDS FOR IFC POWER SUPPLY TO DISCHARGE TO 0 VOLTS. FAILURE TO FOLLOW THIS WARNING COULD RESULT IN PROPERTY DAMAGE, PERSONAL INJURY OR DEATH.

⚠ WARNING

SAFETY HAZARD
BODILY INJURY CAN RESULT FROM HIGH VOLTAGE ELECTRICAL COMPONENTS, FAST MOVING FANS, AND COMBUSTIBLE GAS. FOR PROTECTION FROM THESE INHERENT HAZARDS DURING INSTALLATION AND SERVICING, THE ELECTRICAL SUPPLY MUST BE DISCONNECTED AND THE MAIN GAS VALVE MUST BE TURNED OFF. IF OPERATING CHECKS MUST BE PERFORMED WITH THE UNIT OPERATING, IT IS THE TECHNICIANS RESPONSIBILITY TO RECOGNIZE THESE HAZARDS AND PROCEED SAFELY.

⚠ CAUTION

Sharp Edge Hazard. Be careful of sharp edges on equipment or any cuts made on sheet metal while installing or servicing. Personal injury may result.

Installer's Guide

Upflow models: (*UY/*UX)

Components for KIT15017 (*UY)

No.	Qty.	Drawing Number	Description
1	1	D342097P01	Inducer
2	1	D342263P02	Integrated Furnace Control
3	1	B342140P02	Junction Box Wires
4	1	B341899P06	Door switch to IFC Wire
5	1	B341899P05	Furnace Junction Box Ground Wire
6	1	B341899P01	Transformer Wire - Black
7	1	B341899P02	Transformer Wire - Neutral
8	1	D342127P02	Wire Harness
9	1	18-CH41D1-1	Installation Instructions
10	1	B342017P01	Inducer - Limit
11	1	A341575P01	Inducer Limit Insulation
12	3	N154P1616B	Inducer to mounting bracket screws
13	3	N193P1306B	3/Inducer limit to inducer screws
14	6	A138030P01	Wire Tie
15	1	D343215P01	Conversion Label
16	1	D343217P01	Wiring Diagram
17	1	D343255P01	IFC MOB Bracket
18	4	D343256P01	Plastic Stand Off

Components for KIT15017 (*UY)

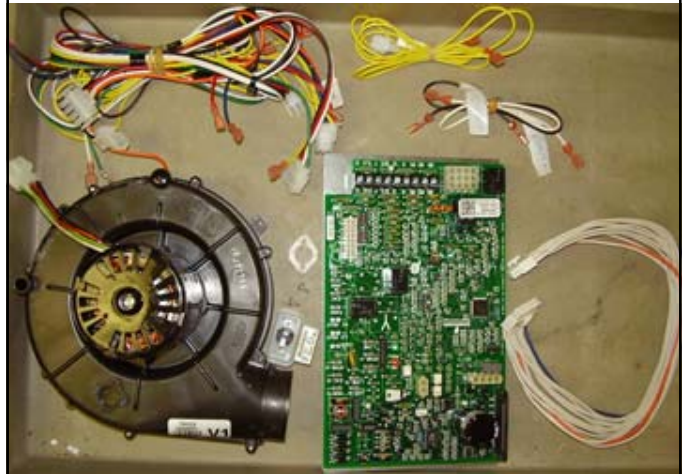

Note: 16 Pin Connector is not in KIT15017

Figure 1

Components for KIT15019 (*UX)

No.	Qty.	Drawing Number	Description
1	1	D342097P01	Inducer
2	1	D342262P02	Integrated Furnace Control
3	1	D342140P02	Junction Box Wire
4	1	B341899P06	Door switch to IFC Wire
5	1	B341899P05	Furnace Junction Box Ground wire
6	1	B341899P01	Transformer Wire - Black
7	1	B341899P02	Transformer Wire - Neutral
8	1	D342127P02	Wire Harness
9	1	18-CH41D1-1	Installation Instructions
10	1	B342017P01	Inducer - Limit
11	1	A341575P01	Inducer Limit Insulation
12	3	N154P1616B	Inducer to mounting bracket screws
13	3	N193P1306B	3/Inducer limit to inducer screws
14	6	A138030P01	Wire Tie
15	1	D343215P03	Conversion Label
16	1	D343217P03	Wiring Diagram
17	1	D343255P01	IFC MOB Bracket
18	4	D343256P01	Plastic Stand Off

Components for KIT15019 (*UX)



Figure 2

Upflow models: (*UY/*UX)

⚠ WARNING

ELECTRIC SHOCK HAZARD
DISCONNECT POWER TO THE UNIT BEFORE REMOVING THE BLOWER DOOR. ALLOW A MINIMUM OF 10 SECONDS FOR IFC POWER SUPPLY TO DISCHARGE TO 0 VOLTS. FAILURE TO FOLLOW THIS WARNING COULD RESULT IN PROPERTY DAMAGE, PERSONAL INJURY OR DEATH.

Removing the existing inducer

1. Remove power from the furnace before beginning work.
2. Remove the front furnace panels.
3. Remove the blower door latching plate if present. See Figure 4.
4. Cut and remove all wire ties.
5. Disconnect the 12-pin wire harness connector at the inducer motor and the 2-pin wire connector to the inducer limit switch.
6. Remove the condensate outlet from the existing inducer.
7. Remove the inducer from the furnace by loosening the clamp on the connection to the flue pipe and removing the three screws holding the inducer to the inducer mounting bracket.
8. Remove the clamp from the inducer and save. Discard the inducer.
9. Clean any remaining RTV from the inducer transition.

Install the new inducer

1. Attach the new inducer limit switch to the inducer capturing the gasket. Use the Philips head screws provided. See Figure 16.
2. Run a bead of high temperature RTV around the channel on the back of the inducer housing, where the inducer will seal to the secondary heat exchanger outlet. See Figure 5.
3. Install the clamp removed from the outlet of the old inducer on the outlet of the new inducer.
4. Install the inducer being careful to not disturb the RTV. The outlet of the inducer fits over the flue pipe.
5. Assure that the channel in the back of the inducer fits securely on the plastic transition from the secondary heat exchanger.
6. Connect the inducer to the inducer mounting bracket with three screws provided.
7. Tighten up the clamp on the outlet of the inducer.
8. Attach condensate drain hose to the inducer.



Figure 3

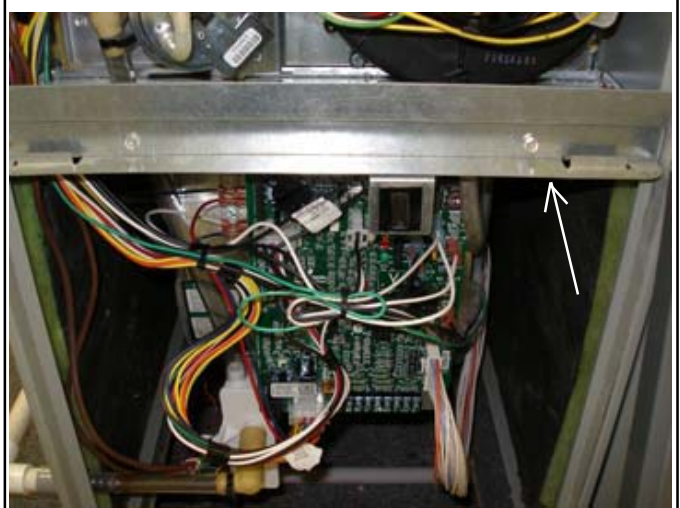

Figure 4



Figure 5

Installer's Guide

Remove the existing IFC and wiring

1. Disconnect all wires and connectors from the IFC.
2. Disconnect wiring to door switch.
3. Disconnect the thermostat connections to the low voltage terminal board on the IFC. It may be helpful to label these wires to allow easy re-assembly to the new IFC.
4. Disconnect the low voltage and high voltage wires to the transformer.
5. Remove the IFC and IFC mounting bracket from the IFC platform by removing the 2 screws at the top of the IFC platform. See Figure 20. Discard the IFC and IFC mounting bracket.
6. Remove burner cover, cut the wire ties on manifold pipe, disconnect wiring to ignitor, and flame sensor. Remove the grounding wire on burner support. Save the screw.
7. Remove wiring to flame rollout switch, primary limit, both pressure switches. Remove grounding screw from pressure switch mounting plate. Save the screw. Disconnect wire harness connector on gas valve.
8. Remove junction box cover and disconnect line and neutral wiring. Remove wire strain relief. Remove the wiring from the grommet in the combustion chamber. Remove wiring grommet in blower deck. Remove wiring through blower deck. See Figure 7.
9. Save the grommet and strain relief.

Install the new IFC and wiring

1. Attach the new IFC to the IFC mounting plate and the mounting plate to the IFC platform using the supplied plastic standoffs.
2. Locate new line voltage wiring bundle B342140P02. Route all four wires (two black and two white) through blower deck opening into line voltage junction box. Connect line, neutral, and ground wires to incoming power in junction box. Connect black wire with 90 degree connector on door switch. Connect white wire labeled 1 to LINE-N on new IFC. Connect black wire labeled HUM3 to HUM terminal on new IFC. Connect black wire labeled EAC2 to EAC terminal on new IFC.
3. Locate and connect single black wire labeled 1 to open terminal on door switch and LINE terminal on new IFC.
4. Connect black wire labeled 4 from line voltage side of transformer to terminal XFMR-H on new IFC and to transformer 115V.
5. Connect white wire labeled 4 from line voltage side of transformer to terminal XFMR-N on new IFC and to transformer 1/4" C terminal.
6. (On *UY models) If line choke is present, connect the black lead with 1/4" flag on the choke to CIR-H terminal of the new IFC. Connect the white wire from the 5-pin connector of the variable speed indoor blower to the CIR-N terminal of the new IFC. If choke is not present, on the 5-pin connector of variable speed indoor blower motor, connect the



Figure 6



Figure 7



Figure 8

black lead to CIR-H and the white lead to CIR-N. Route the green ground lead from the 5-pin connector through the blower deck to the pressure switch grounding screw. Connect the 16-pin harness to the new IFC. (On *UX models) Connect the 4 speed tap wires from the indoor blower motor to the COOL, HI HEAT, LO HEAT, and PARK terminals on the new IFC. Connect the white wire from the blower motor to the CIR-N terminal of the new IFC.

7. Locate low voltage wiring bundle. Route bundle with twelve pin connector through blower deck into blower compartment. Connect twelve pin connector to new IFC, connect red and blue wires from bundle to low voltage transformer 3/16" terminals 24 and C. Connect four pin connector from inducer motor to new IFC, connect two pin connector from ignitor to new IFC, connect white wire from flame sensor to FP terminal on new IFC. Connect 12-pin connector to the new IFC.
8. Note: PS2 has the highest negative pressure label. Connect 4 pin wire connector plug to inducer motor, connect yellow wire labeled 6 with 90 degree double connector to PS2 terminal, from the double terminal connect other yellow wire labeled 7 to PS1, connect brown wire to PS2, connect orange wire to PS1, connect yellow wires labeled 1 and 4 to inducer housing limit switch, connect green wire to other green wire on pressure switch grounding plate. See Figure 9.
9. Connect three pin wire connector plug to gas valve, connect two 90 degree yellow wires labeled 4 and 2 to rollout switch,
10. Connect two yellow wires, one labeled 2 and yellow wire with no label to the primary limit terminal. See figure 10.
11. Route four wire bundle with two wire connector plug, ignitor flame sensor wire, and ground from the wiring harness behind the junction box and through the burner compartment grommet. Connect two pin wire connector plug to the ignitor. Connect white wire to flame sensor. Connect ground wire to the grounding screw on the burner support. See Figure 11.
12. Secure wires to the manifold pipe using wire ties provided.
13. Reinstall burner box cover with screws removed earlier.
14. Reinstall junction box cover with screws removed earlier.
15. Snap wire bundle retainer clip on wire harness into the hole located on the junction box cover.
16. Insert wiring harness grommet into blower deck.
17. Reattach blower door latching plate if present.
18. Reconnect thermostat wiring to low voltage terminals on IFC.
19. Using the included wiring diagram, verify that wiring is correct.
20. Go to the IFC Setup section to finish the setup procedure.

18-CH41D1-1



Figure 9



Figure 10



Figure 11

Installer's Guide

Downflow models: (*DY/*DX)

Components for KIT15018 (*DY)

No.	Qty.	Drawing Number	Description
1	1	D342097P01	Inducer
2	1	D342263P02	Integrated Furnace Control
3	1	B341898P08	Junction Box Wire
4	1	B341899P05	Furnace Junction Box Ground wire
5	1	B341899P01	Transformer Wire - Black
6	1	B341899P02	Transformer Wire - Neutral
7	1	B341897P08	Limit Wire Harness
8	1	B341900P01	2 Pin Wire Harness df
9	1	B341900P03	2 Pin Wire Harness df
10	1	D342127P04	Wire Harness
11	1	B341900P06	Wire Harness 2 pin DF L
12	1	18-CH41D1-1	Installation Instructions
13	1	B342017P02	Inducer - Limit
14	1	A341575P01	Inducer Limit Insulation
15	3	N154P1616B	Inducer to mounting bracket screws
16	3	N193P1306B	3/Inducer limit to inducer screws
17	6	A138030P01	Wire Tie
18	1	D343215P02	Conversion Label
19	1	D343217P02	Wiring Diagram
20	1	B341734P02	Wire Harness 16 pin vs mtr
21	1	D343255P01	IFC MOB Bracket
22	4	D343256P01	Plastic Stand Off
23	1	B341728P05	Wire Harness 5 Pin VS Motor

Components for KIT15018 (*DY)

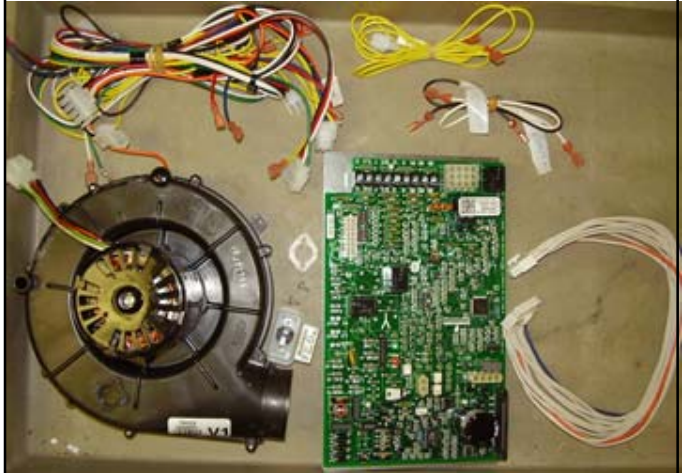

Figure 12

Components for KIT15020 (*DX)

No.	Qty.	Drawing Number	Description
1	1	D342097P01	Inducer
2	1	D342262P02	Integrated Furnace Control
3	1	B341898P08	Junction Box Wire
4	1	B341899P05	Furnace Junction Box Ground wire
5	1	B341899P01	Transformer Wire - Black
6	1	B341899P02	Transformer Wire - Neutral
7	1	B341897P08	Wire Limit series
8	1	B341900P01	Wire Harness 2 pin df
9	1	B341900P03	Wire Harness 2 pin df
10	1	D342127P04	Wire Harness DF 90 2 Stg
11	1	B341900P06	Wire Harness 2 pin DF L
12	1	18-CH41D1-1	Installation Instructions
13	1	B342017P02	Inducer - Limit
14	1	A341575P01	Inducer Limit Insulation
15	3	N154P1616B	Inducer to mounting bracket screws
16	3	N193P1306B	3/Inducer limit to inducer screws
17	6	A138030P01	Wire Tie
18	1	D343215P04	Conversion Label
19	1	D343217P04	Wiring Diagram
20	1	D343255P01	IFC MOB Bracket
21	4	D343256P01	Plastic Stand Off

Components for KIT15020 (*DX)

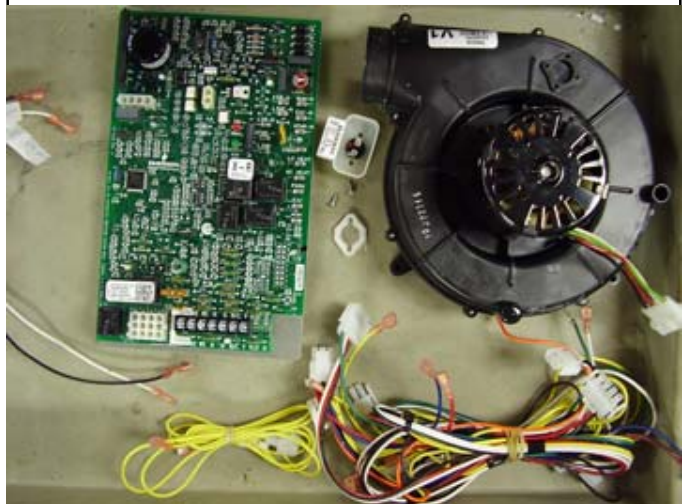

Figure 13

Downflow models: (*DY/*DX)

⚠ WARNING

ELECTRIC SHOCK HAZARD
DISCONNECT POWER TO THE UNIT BEFORE REMOVING THE BLOWER DOOR. ALLOW A MINIMUM OF 10 SECONDS FOR IFC POWER SUPPLY TO DISCHARGE TO 0 VOLTS. FAILURE TO FOLLOW THIS WARNING COULD RESULT IN PROPERTY DAMAGE, PERSONAL INJURY OR DEATH.

Removing the existing inducer

1. Remove power from the furnace before beginning work.
2. Remove the front furnace panels.
3. Cut and remove all wire ties.
4. Disconnect 12 pin harness from the inducer motor and 2 pin connector to inducer housing limit switch.
5. Loosen hose clamp between inducer housing and transition pipe.
6. Remove inducer condensate hose from inducer housing.
7. Remove 3 inducer housing mounting screws.
8. Remove the inducer assembly by rotating inducer clockwise and pulling out. Save the hose clamp and mounting screws.
9. Clean any remaining RTV from the inducer transition.

Install the new inducer

1. Attach the new inducer limit to the new inducer housing with the two Phillips head screws with the gasket between inducer housing and limit switch. See Figure 16.
2. Run a bead of high temperature RTV silicone in the channel of the inlet air side of the inducer housing. (the channel is approximately 2.5" in diameter) See Figure 17.
3. Install hose clamp on outlet of new inducer.
4. Install new inducer on the receptacle and install the three mounting screws.
5. Tighten hose clamp and re-attach inducer condensate hose to the new inducer housing. See Figure 14.



Figure 14



Figure 15



Figure 16



Figure 17

Installer's Guide

Removing the IFC and wiring

1. Remove burner box cover. See Figure 18.
2. Cut the wire ties on the manifold pipe.
3. Disconnect ignitor wires, flame sensor wire and ground terminal on the burner support. Remove these wires from the burner box grommet.
4. Disconnect the gas valve wires.
5. Disconnect #1 labeled yellow wire from primary limit switch and #3 yellow wire from the roll-out switch.
6. Remove furnace junction box cover and remove the HUM and EAC wires from the junction box.
7. Remove the blower deck wire grommet and pull the disconnected wires through the blower deck. See Figure 19.
8. Remove all high and low voltage wires from the existing IFC.
9. Remove wires from the transformer.
10. Remove all wires from both pressure switches.
11. **Remove the IFC and IFC mounting plate by removing two screws located at the top of the mounting plate.** See Figure 20. Discard the IFC and mounting plate. Retain the screws.
12. Remove the screws from the top panel that hold the IFC platform. Remove the platform and retain for later use.

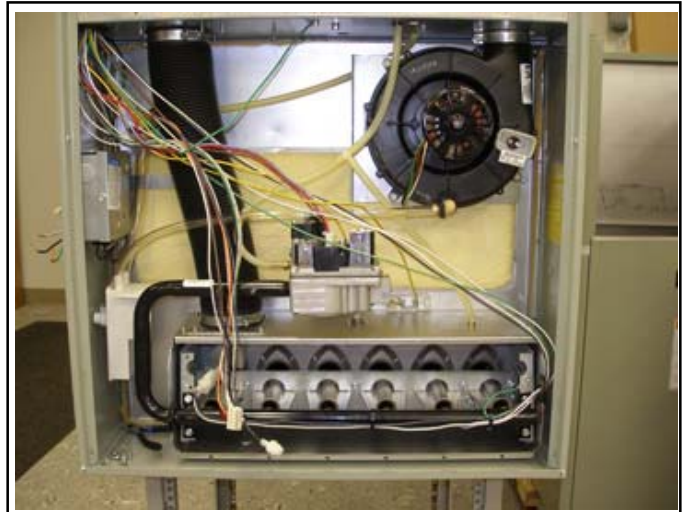

Figure 18

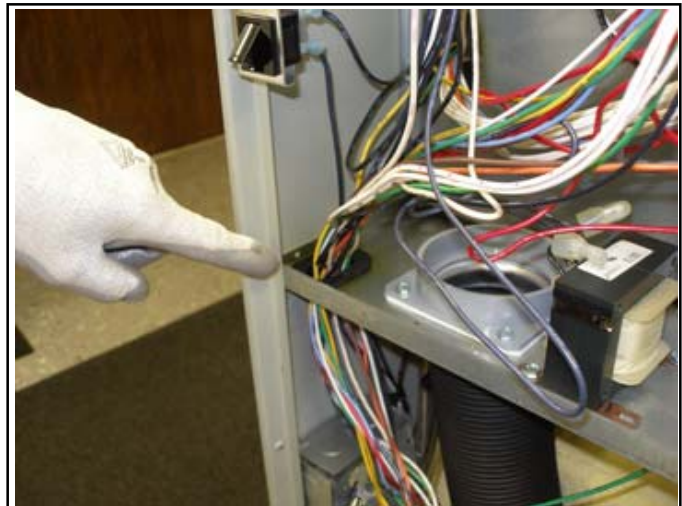

Figure 19



Figure 20

13. Remove inlet air pipe & exhaust vent pipe from furnace.
14. Remove inner blower door. See Figure 21.
15. Remove yellow #5 and yellow #3 wires from reverse flow switch. See Figure 22.
16. (For *DY models only) Remove the 16 pin and 5 pin wire harnesses from the variable speed blower motor and discard.

NOTE: The *DX models use existing indoor motor leads for speeds and neutral.

17. (For *DY models with line choke) Locate the line choke in the control compartment (Figure 21). Cut the black lead at the bell cap of the line choke which is rotated to the Variable Speed indoor blower motor.



Figure 21



Figure 22

Installer's Guide

Installing the new IFC and wiring

1. Locate wiring harness B341900P06 (2 yellow wires with ¼" terminals on one end & 2 pin female connector on the other). Connect the ¼" terminals to the reverse flow switch. Thread the 2 pin connector back into the IFC compartment.
2. (*DY models) Install (B341734P02) 16 pin connector and 5 pin wire harness (B341728P05) to the variable speed indoor blower motor and thread through the grommet in the inner blower door.
(*DX models) Thread the four speed taps and white neutral leads of the inner blower motor through the grommet in the inner blower door.
3. Replace inner blower door.
4. Replace inlet & vent pipes.
5. Install the IFC with adapter plate and four plastic standoffs to the control platform. Reinstall the IFC platform.
6. Attach 17" black wire with ¼" connectors on both ends to the primary side of transformer and to the XFMR-H terminal of the IFC.
7. Attach 17" white wire with ¼" connectors on both ends to the primary side of transformer and to the XFMR-N terminal of the IFC.

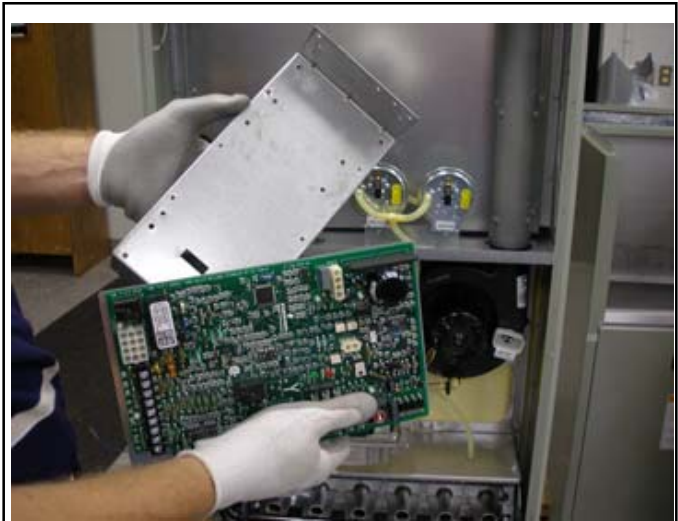

Figure 23

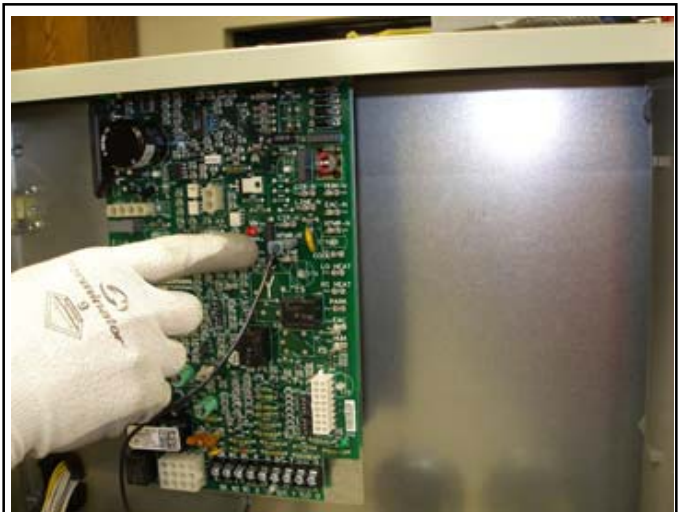

Figure 24

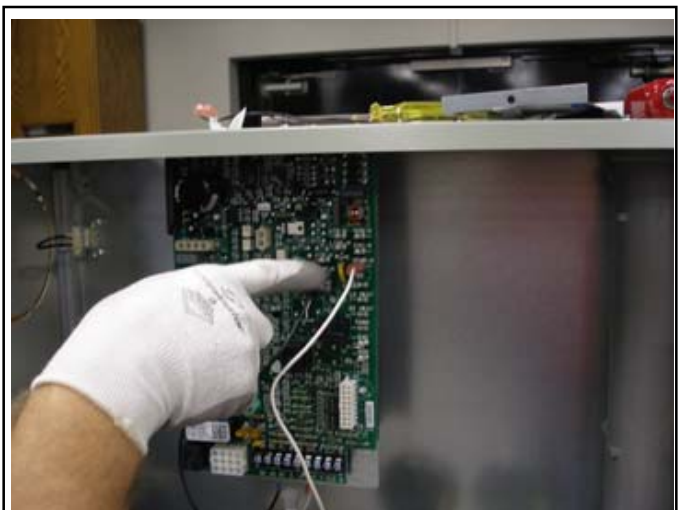

Figure 25

8. Using wiring harness labeled “D342127P04 DY-DX-R Long”. Thread the end with this label from the combustion area through the blower deck into the control compartment.
9. Attach the 12-pin low voltage connector, 4-pin (red, black & white wire) inducer motor connector and 2-pin (black & white wire) ignitor connector to the IFC.
10. Attach the single white wire with ¼” connector taped to with the 2-pin ignitor & 4-pin inducer connector to the FP (flame probe) terminal on the IFC.
11. (*DY models with line chokes) On the black lead from the 5-pin high voltage lead to the indoor blower motor, cut the single motor connection off. Wire nut this lead to the black lead of the line choke.



Figure 26



Figure 27

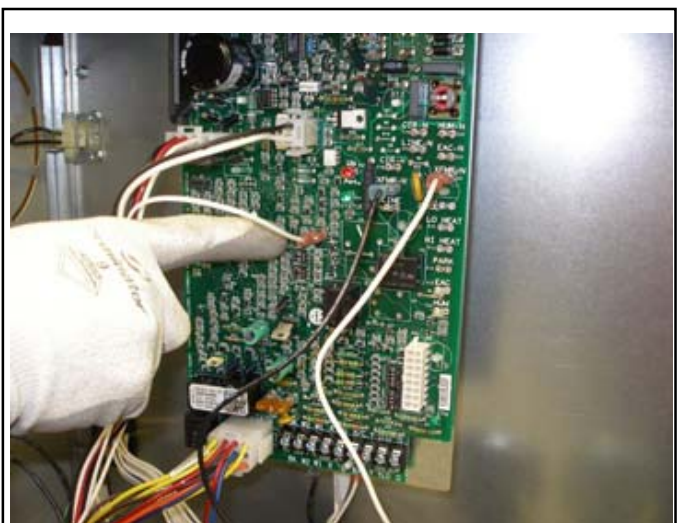

Figure 28

Installer's Guide

12. Connect the 3/16" connectors of the red & blue leads from the 12-pin low voltage connector to the 24 volt side of the transformer.
13. From the inner blower door connect black 115v. wire labeled one to the LINE terminal on the IFC.
14. Connect the white lead from the furnace junction box 115 Volt power neutral to the LINE-IN terminal on the IFC.
15. (*DY models) Connect the black 115v. lead marked "8" from the 5-pin connector of the ECM indoor blower motor or line choke to the CIR-H terminal of the IFC. Connect the neutral lead from the 5 pin connector of the indoor blower motor to the CIR-N terminal of the IFC. Connect the 16 pin ECM indoor motor leads to the IFC.
16. (*DX models) Connect the neutral lead from the PSC motor to the CIR-N terminal of the IFC. connect the black lead to Cool, Blue to Heat, Yellow and Red to the park terminals of the IFC.

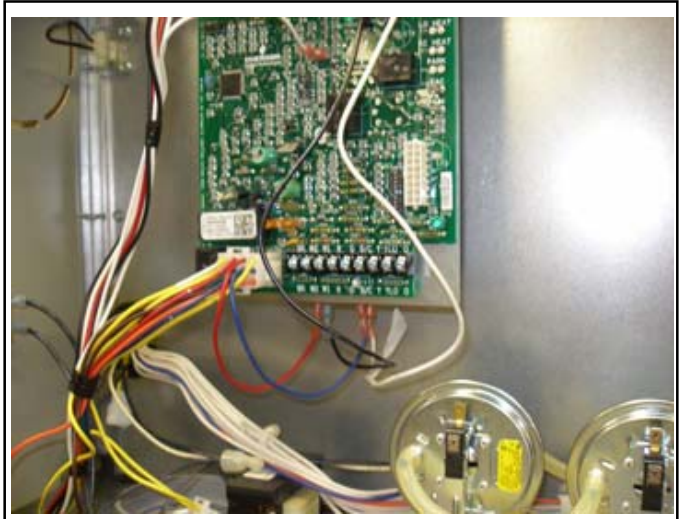

Figure 29

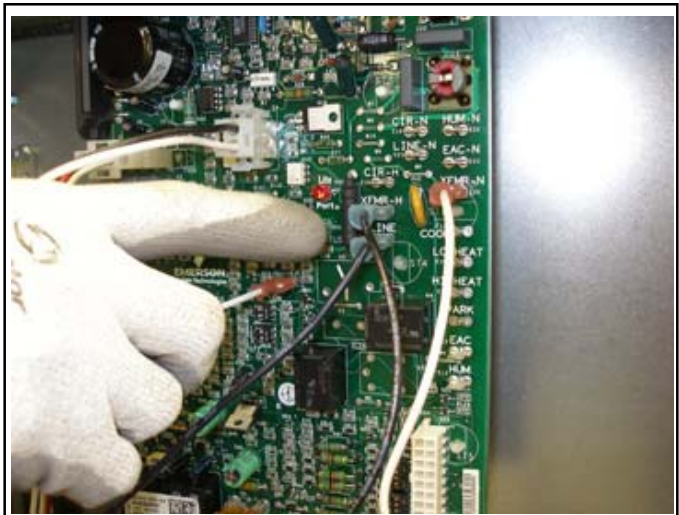

Figure 30



Figure 31

17. Connect the male & female 2-pin connectors with yellow wires together. (reverse flow switch leads)
18. Connect yellow #6 wire with 90 degree $\frac{1}{4}$ " terminal to one side of pressure switch # 1 (low fire) switch terminals.
19. Connect yellow # 7 wire from pressure switch # 1 to one side of pressure switch # 2 (high fire) switch terminals.
20. Connect orange wire with 90 degree $\frac{1}{4}$ " terminal to the other switch terminal of pressure switch # 1 (low fire)
21. Connect brown wire with 90 degree $\frac{1}{4}$ " terminal to the other switch terminal of pressure switch # 2 (high fire).

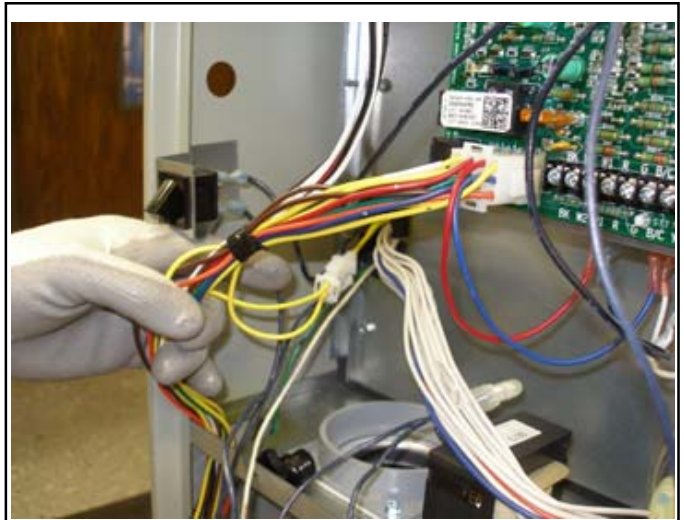

Figure 32

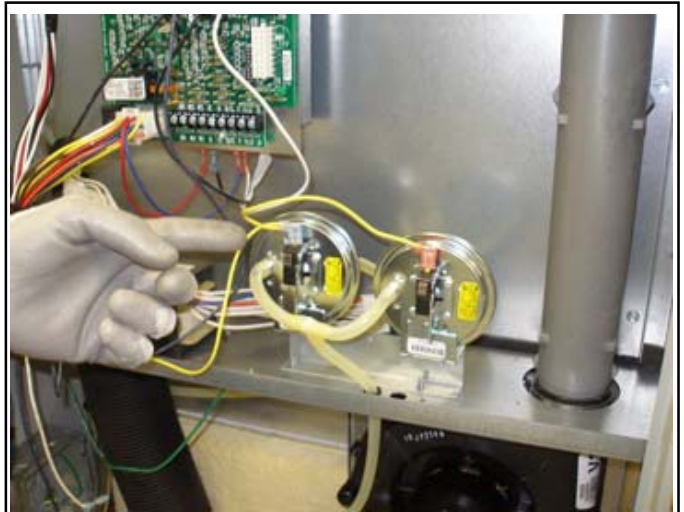

Figure 33

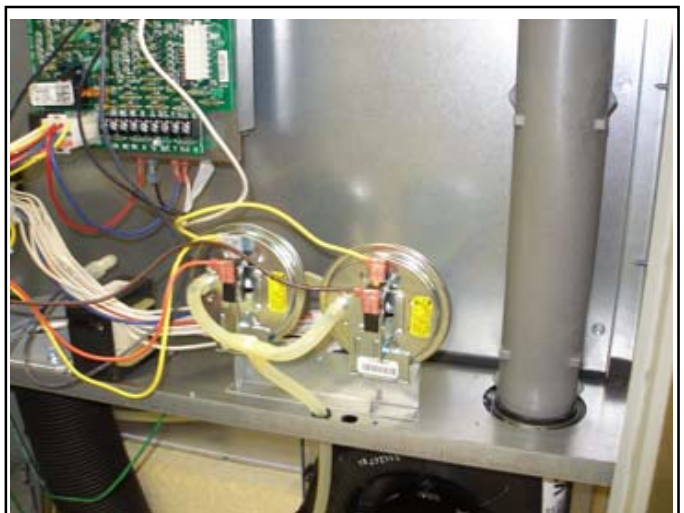

Figure 34

Installer's Guide

22. In the burner compartment, connect the 4-pin inducer connectors together.
23. Attach the green grounding lead of the 4-pin inducer connector to the grounding terminal.
24. Connect yellow #1 & #4 with the straight ¼" connector to the inducer limit switch terminal. See Figure 37.

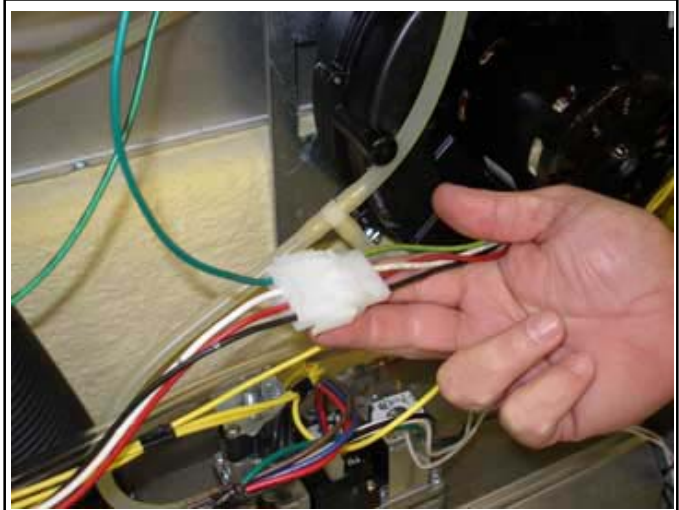

Figure 35

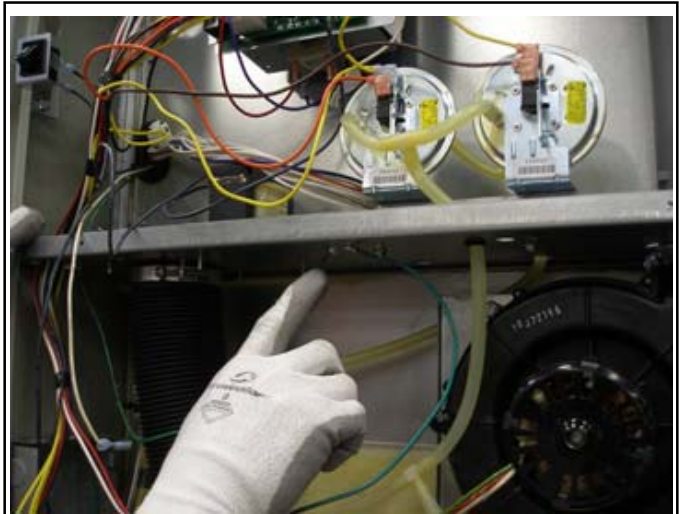

Figure 36



Figure 37

25. Connect yellow #4 & #5 connected to the 90 degree connector to the limit on the burner box (roll-out switch). See Figure 38.
26. Connect yellow # 8 with ¼" connector to the terminal of the high – limit switch.
27. Connect the 3-pin (brown, red & blue wires) gas valve connector to the gas valve terminals. See Figure 39.
28. Route the remaining four wires (single white flame sensor wire, 2-pin black & white ignitor wires and green grounding wire) through the burner box wire grommet. See figure 40.
29. Connect the flame sensor ¼" wire connector to the flame sensor. Connect the ignitor connectors together. Fasten the grounding eye-ring under the ¼" head screw.
30. Wire tie the wires to the manifold pipe.
31. Install the burner box cover.
32. Route the 115v. black and neutral white wire with strain relief into the junction box and reconnect to power leads.
33. Install junction box cover and snap strain relief wire tie to the cover.
34. Install wire grommet into the blower deck.
35. (*DY models) Go to the IFC Setup section to set up the dip switches and finish the setup procedure.
36. Restore power and check out the furnace operation.



Figure 38

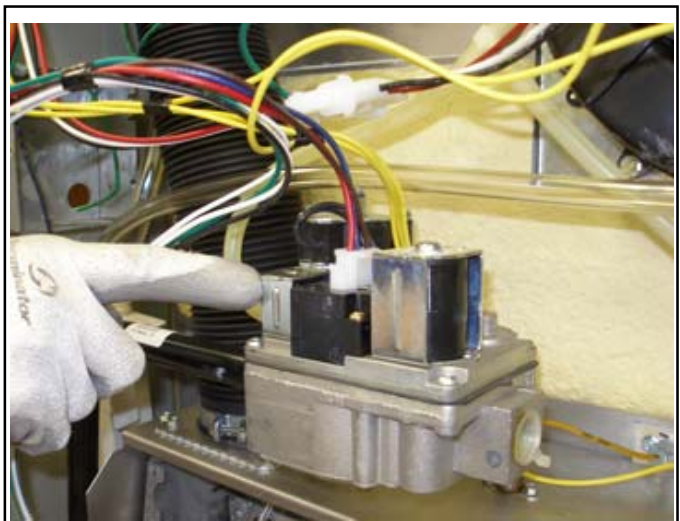

Figure 39



Figure 40

Installer's Guide

IFC Setup

Heating: The Integrated Furnace Control (IFC) controls the Variable Speed Indoor Blower. The blower "on" time is fixed at 45 seconds after ignition. The FAN-OFF period is field selectable by dip switches #1 and #2 located on the Integrated Furnace Control between the 5-pin and 9-pin wire connectors. The delay may be set at 60, 100, 140, or 180 seconds. The factory setting is 100 seconds (See unit wiring diagram).

W1-W2 stage delay (jumpered together) is field selectable by dip switch SW-1, #1 and #2 at .5, 5, 10 or 15 minutes. The factory setting is 10 minutes. (See wiring diagram).

Cooling: The fan delay-off period is set by dip switches on the Integrated Furnace Control. The options for cooling delay off is field selectable by dip switches #5 and #6.

The following table and graph explain the delay-off settings:

This unit is equipped with a blower door switch which cuts power to the blower and Gas Valve causing shut-down when the door is removed.

Reapply power and check for proper furnace operation.

SWITCH SETTINGS		SELECTION	NOMINAL AIRFLOW
5 - OFF	6 - OFF	NONE	SAME
5 - ON	6 - OFF	1.5 MINUTES	100% *
5 - OFF	6 - ON	3 MINUTES	50%
5 - ON	6 - ON	Enhanced Mode**	50 - 100%

* - This setting is equivalent to BAY24X045 relay benefit.

** - This selection provides ENHANCED MODE, which is a ramping up and ramping down of the blower speed to provide improved comfort, quietness, and potential energy savings. See Wiring Diagram notes on the unit or in the Service Facts for complete wiring setup for ENHANCED MODE. The graph which follows, shows the ramping process.

See Wiring Diagram on the unit or in the Service Facts for complete wiring setup for Enhanced Mode.

Airflow Dipswitch Settings

INDOOR MOTOR AIRFLOW SELECTION CHART					
OUTDOOR UNIT (SIZE IN TONS)				COOLING AIRFLOW SETTINGS	
SWITCH SETTING	*UY/DY060	*UY/DY080	*UY/DY100	*UY/DY120	
1-OFF 2-OFF**	3	3.5 SEE NOTE 7	4	5	3-ON 4-OFF (HIGH) 450 CFM/TON
1-ON 2-OFF	2.5	3	3.5	4	3-OFF 4-OFF** (NORMAL) 400 CFM/TON
1-OFF 2-ON	2	2.5	3	3.5	3-OFF 4-ON (LOW) 350 CFM/TON
1-ON 2-ON	1.5	2	2.5	--	
HEATING AIRFLOW SETTING - CFM (1st STAGE / 2nd STAGE)					
7-OFF 8-OFF (HIGH)	860/1290	1150/1400	1350/1900	1550/2150	
7-ON 8-OFF (NORMAL)	750/1125	1000/1400	1150/1600	1350/1950	
7-OFF 8-ON**(MED-LOW)	675/1012	900/1250	1000/1450	1200/1850	
7-ON 8-ON (LOW)	600/900	800/1100	900/1300	1050/1650	
COOLING OFF DELAY OPTIONS					
	SELECTION	NORMAL SELECTION			
5-OFF 6-OFF	NONE	SAME			
5-ON 6-OFF**	90 SEC	100% (BAY24X045 EQUIVALENT)			
5-OFF 6-ON	180 SEC	50%			
5-ON 6-ON	COMFORT-R	50%-100%			

NOTES:

- GREEN LIGHT FLASHES ONCE PER 100 CFM AS PER DIP SWITCH SETTINGS.
- FOR COOLING SYSTEM, Y MUST BE CONNECTED TO THE LOW VOLTAGE TERMINAL BOARD (LVTB).
-HEAT PUMP SYSTEMS, Y AND O MUST BE CONNECTED TO THE LVTB.
-2 SPEED SYSTEMS, USE YLO FOR LOW AND Y FOR HIGH SPEED CONNECTIONS TO LVTB.
- IF A HUMIDSTAT IS USED:
- *UY/DY: CUT JUMPER ABOVE BK & R AND CONNECT BETWEEN BK & R TERMINALS.
- COOLING-ONLY/NON-HEAT PUMP SYSTEMS, JUMPER Y TO O FOR HUMIDSTAT OPERATIONS.
- SEE SERVICE FACTS FOR COMFORT-R TIME DELAY SETTINGS.
- POWER MUST BE OFF WHEN DIP SWITCHES ARE SET OR RESET.
- RED INDICATOR LIGHTS (Y, BK, AND G) WILL COME ON WHEN ENERGIZED THRU THE CONTROL SYSTEM.
- *UY080 ONLY

* PREFIX MAYBE "T" OR "A" / ** FACTORY SETTING
DWG. NO. B34181P04

Fault Codes

INTEGRATED FURNACE CONTROL RED LED "ERROR" FLASH CODES	
2 Flashes ---	System Lockout (Retries or Recycles exceeded)
3 Flashes ---	Draft Pressure Error - Possible problems: a) Venting problem b) Pressure switch problem c) Inducer problem
4 Flashes ---	Open Temperature Limit Switch
5 Flashes ---	Flame sensed when no flame should be present
6 Flashes ---	115 volt AC power reversed, ignitor (Triac) fault, poor grounding or system voltage too low
7 Flashes ---	Gas valve circuit error
8 Flashes ---	Low flame sense
9 Flashes ---	Open Inducer Limit switch
10 Flashes ---	Inducer communication error
Solid ---	Internal GV error or Low TH voltage
Solid Red w/Solid Green "STATUS" LED	Continuous Reset caused by a blown fuse or internal error.

Fault Code Recovery

On power up, last 4 faults, if any, will be flashed on the red LED. The newest fault detected will flash first and the oldest last. There will be a 2 second delay between fault code flashes. Solid red LED error codes will not be displayed.

The Green LED will be on solid during last fault recovery. At any other time the control is powered, the Green LED indicator light will operate as shown in Table 14 and the red LED will flash LitePort data (one flash) every 20 seconds.

Table 25

INTEGRATED FURNACE CONTROL GREEN "STATUS" LED FLASH CODES	
Flashing Slow ---	Normal - No call for Heat
Flashing Fast ---	Normal - Call for Heat

KIT15017 Schematic

KIT15017

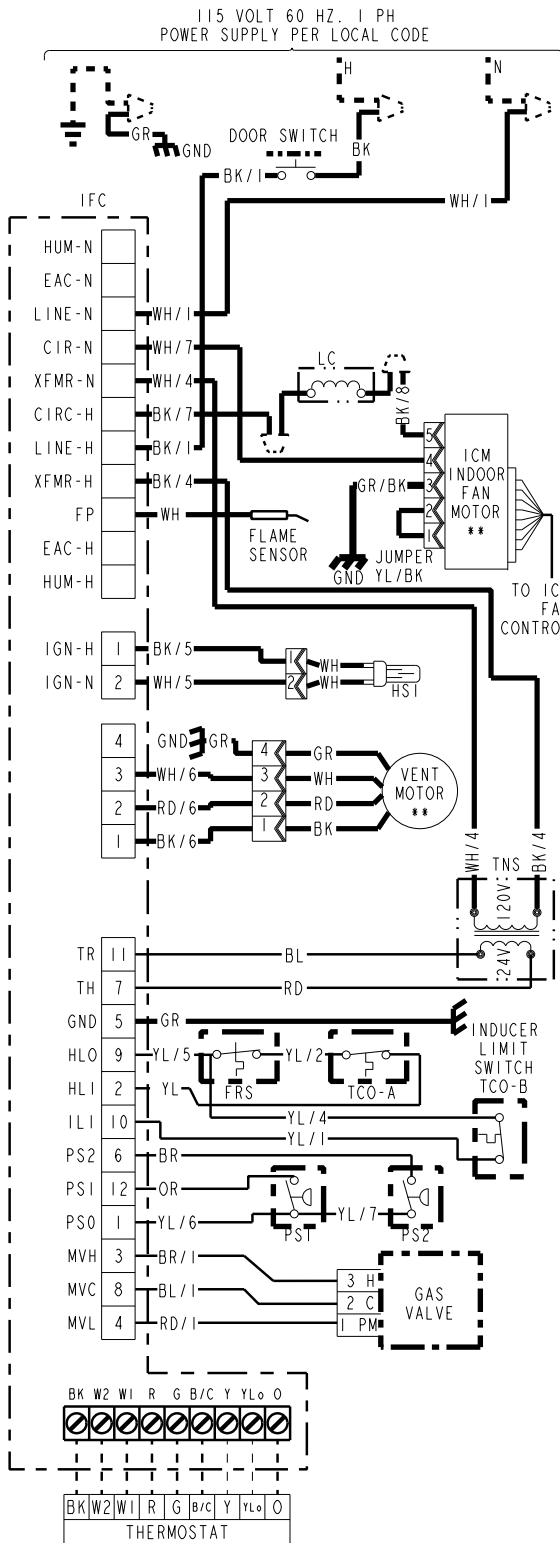

SEE NOTES 2, 3, 5, 6, 7, 8, 9

DIAGNOSTIC CODES (SEE NOTE 13)	
RED LED - LitePort 1m Data - 1 Flash every 20 seconds	
2 FLASHES - SYSTEM LOCKOUT RETRIES OR RECYCLES EXCEEDED	6 FLASHES - 115 VOLT AC POWER REVERSED OR IGNITER FAULT
3 FLASHES - PRESSURE SWITCH FAULT	7 FLASHES - GAS VALVE CIRCUIT ERROR
4 FLASHES - OPEN LIMIT SWITCH	8 FLASHES - LOW FLAME SENSE SIGNAL
5 FLASHES - FLAME SENSED WHEN NO FLAME SHOULD BE PRESENT	9 FLASHES - OPEN INDUCER LIMIT
	10 FLASHES - INDUCER COMMUNICATION FAULT
	CONTINUOUS ON - INTERNAL CONTROL FAILURE
GREEN LED - STATUS	
SLOW FLASH - NORMAL, NO CALL FOR HEAT	
FAST FLASH - NORMAL, CALL FOR HEAT PRESENT	
GREEN AND RED LED'S ON CONTINUOUS - FUSE OPEN OR INTERNAL CONTROL FAILURE	

WARNING ⚠	CAUTION ⚠
HAZARDOUS VOLTAGE DISCONNECT ALL ELECTRICAL POWER INCLUDING REMOTE DISCONNECTS BEFORE SERVICING. FAILURE TO DISCONNECT POWER BEFORE SERVICING CAN CAUSE SEVERE PERSONAL INJURY OR DEATH.	USE COPPER CONDUCTORS ONLY! UNIT TERMINALS ARE NOT DESIGNED TO ACCEPT OTHER TYPES OF CONDUCTORS. FAILURE TO DO SO MAY CAUSE DAMAGE TO THE EQUIPMENT.

INTEGRATED FURNACE CONTROL

REPLACE WITH PART CNT 04678 OR EQUIVALENT	TIMINGS
ELECTRICAL RATING	PREPURGE: 0 SEC.; INTERPURGE: 60 SEC.
INPUT: 25 V.A.C., 60 HZ.	POST PURGE: 5 SECONDS
XFMR SEC. CURRENT: 450 MA. + MV LOAD	IGNITOR WARMUP: 20 SECONDS
MV OUTPUT: 1.5 A @ 24 V.A.C.	IAP: 3; TFI: 5 SECONDS
IND OUTPUT: 3 PHASE OUTPUT	RETRIES: 2; RECYCLES: 10
IGN OUTPUT: 2.0 A @ 120V.A.C.	HEAT ON DELAY: 45 SECONDS
CIRC. BLOWER OUTPUT: 14.5 FLA, 25 LRA @ 120 VAC	COOL ON DELAY: 0 SECONDS
HUMIDIFIER & AIR CLEANER	AUTO RESTART: 60 MINUTES
MAX. LOAD: 1.0 A @ 120 VAC	AUTO RESTART PURGE: 15 SECONDS

TCO THERMAL CUT OUT	LINE } FACTORY WIRING	BK BLACK	GR GREEN
PS PRESSURE SWITCH	24 V } WIRING	WH WHITE	BR BROWN
FRS FLAME ROLLOUT SWITCH	LINE } FIELD WIRING	YL YELLOW	RD RED
	24 V } WIRING	OR ORANGE	BL BLUE
FP FLAME SENSOR	** INTERNAL THERMAL PROTECTION	WIRE COLOR	
CHASSIS GROUND	CF CAPACITOR	BK/1 NUMBER ID (IF ANY)	
HSI HOT SURFACE IGNITER	COIL	L LINE	TH 24 VAC (HOT)
DOOR SWITCH		N NEUTRAL	TR 24 VAC (COMMON)
FUSE		GND GROUND	MV MAIN GAS VALVE
		B/C COMMON	TNS TRANSFORMER
		HLO HIGH LIMIT OUTPUT	ILI INDUCER LIMIT INPUT
		HLI HIGH LIMIT INPUT	

NOTES:

- IF ANY OF THE ORIGINAL WIRING AS SUPPLIED WITH THIS FURNACE MUST BE REPLACED, IT MUST BE WITH WIRE HAVING A TEMPERATURE RATING OF AT LEAST 105 C.
- THERMOSTAT HEAT ANTICIPATOR SETTING: FIRST STAGE .38 AMPS, SECOND STAGE .13 AMPS. IF SETTING IS NOT FIXED ON THERMOSTAT, FOR SINGLE STAGE HEATING THERMOSTAT SET AT .51 AMPS.
- FOR PROPER OPERATION OF COOLING SPEED, "Y" TERMINAL MUST BE CONNECTED TO THE ROOM THERMOSTAT.
- THESE LEADS PROVIDE 120V POWER CONNECTIONS FOR ELECTRONIC AIR CLEANER (EAC) AND HUMIDIFIER (HUM). MAX. LOAD: 1.0 AMPS EACH.
- JUMPER W1 AND W2 FOR SINGLE STAGE HEATING THERMOSTAT, SECOND STAGE WILL BE ENERGIZED, DELAYED PER STAGING DELAY SETTING.
- GREEN LIGHT (CFM) FLASHES ONCE PER 100 CFM COMMAND.
- FOR HEAT PUMP SYSTEMS Y AND O MUST BE CONNECTED TO THE LOW-VOLTAGE TERMINAL BOARD.
- FOR TWO SPEED SYSTEMS, USE YLO FOR LOW SPEED AND Y FOR HIGH SPEED CONNECTION TO THE LOW-VOLTAGE TERMINAL BOARD.
- OPTIONAL HUMIDSTAT IS TO BE CONNECTED BETWEEN THE "R" AND "BK". FACTORY INSTALLED JUMPER "R" TO "BK" (BK JUMPER) ON THE CIRCUIT BOARD MUST BE CUT IF OPTIONAL HUMIDSTAT IS USED. THE JUMPER MUST ALSO BE CUT WHEN APPLYING AN AIRFLOW COMMAND SIGNAL TO THE "BK" INPUT SUCH AS WITH THE VARIABLE SPEED SINGLE-ZONE AND MULTI-ZONE SYSTEM CONTROLLERS. ON SINGLE SPEED COOLING ONLY / NON-HEAT PUMP SYSTEMS, JUMPER "Y" TO "O" FOR PROPER OPERATION OF THE DELAY PROFILES AND THE HUMIDSTAT. FOR TWO COMPRESSOR OR TWO SPEED SYSTEMS, JUMPER "YLO" TO "O".
- SEE INDOOR MOTOR AIRFLOW SELECTION CHART, LOCATED IN THE FURNACE FOR DIP SWITCH SETTINGS TO SET AIRFLOW AND COOLING OFF DELAYS.
- POWER MUST BE OFF WHEN DIP SWITCHES ARE SET.
- USED FOR 100,000 BTU/HR AND 120,000 BTU/HR MODELS ONLY.
- ON POWER-UP, LAST FOUR FAULTS, IF ANY, WILL BE FLASHED ON RED LED. GREEN LED WILL BE SOLID ON DURING LAST FAULT RECOVERY.

Installer's Guide

KIT15019 Wiring diagram

IMPORTANT:

INTEGRATED CONTROL IS POLARITY SENSITIVE.
HOT LEG OF 120V POWER SUPPLY MUST BE
CONNECTED TO THE BLACK POWER LEAD AS
INDICATED ON WIRING DIAGRAM.

KIT15019

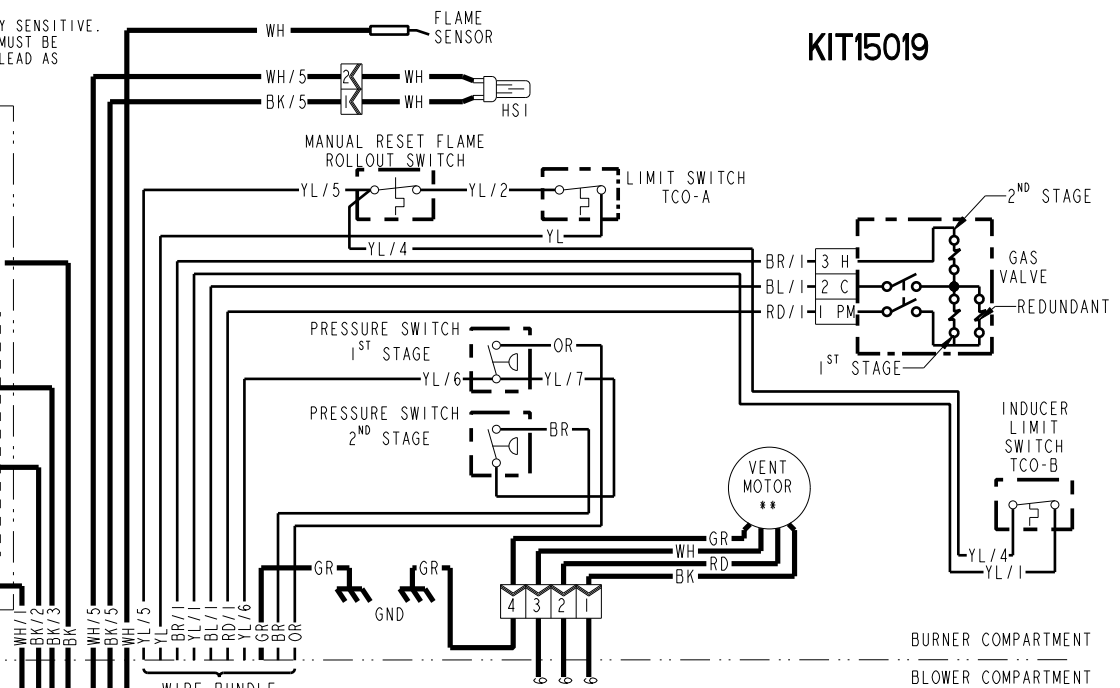
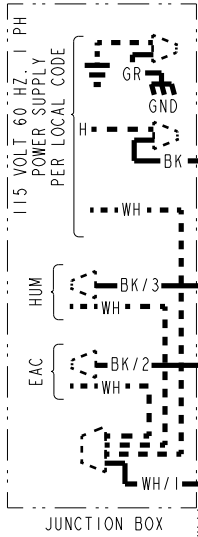

STAGING DELAY		
DS1	DS2	MIN.
ON	OFF	0.5
OFF	ON	5
OFF	OFF	10*
ON	ON	15

DETAIL A



HEAT "OFF" DELAY		
DS1	DS2	DELAY
ON	OFF	60 SEC
ON	ON	100 SEC*
OFF	ON	140 SEC
OFF	OFF	180 SEC

DETAIL B



DS3	COOL OFF DELAY
ON	0 SECONDS*
OFF	80 SECONDS

2 PIN CONNECTOR	
1.	IGN IGNITOR
2.	IGN-N IGNITOR-NEUTRAL

4 PIN CONNECTOR	
1.	INDUCER, PHASE 1
2.	INDUCER, PHASE 2
3.	INDUCER, PHASE 3
4.	NOT USED, (CONTROL END)

12 PIN CONNECTOR	
1.	PSO PRESSURE SWITCH OUTPUT
2.	HL1 HIGH LIMIT INPUT
3.	MVH VALVE HIGH STAGE
4.	MVL VALVE LOW STAGE
5.	GND GROUND
6.	PS2 HPS INPUT
7.	TH 24VAC
8.	MVC VALVE COMMON
9.	HLO HIGH LIMIT OUTPUT
10.	ILI INDUCER LIMIT INPUT
11.	TR 24V RETURN
12.	PSI LPS INPUT

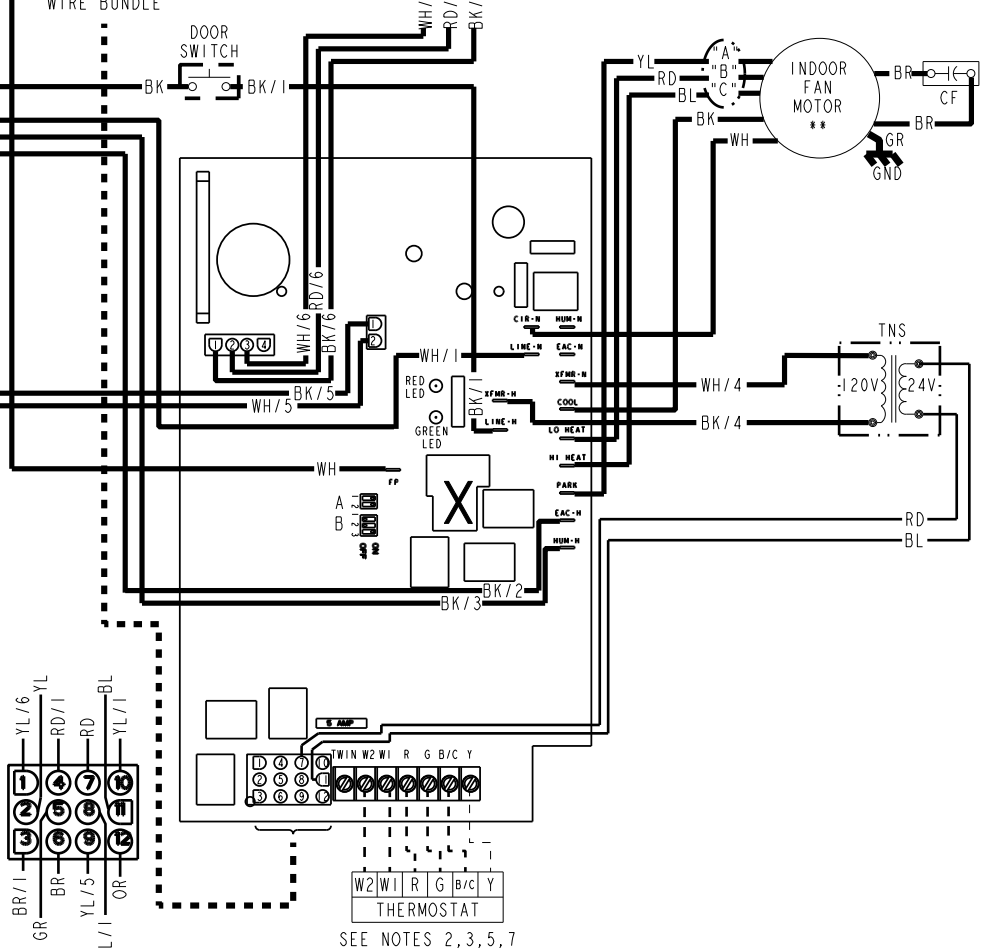

KIT15019 Schematic

KIT15019

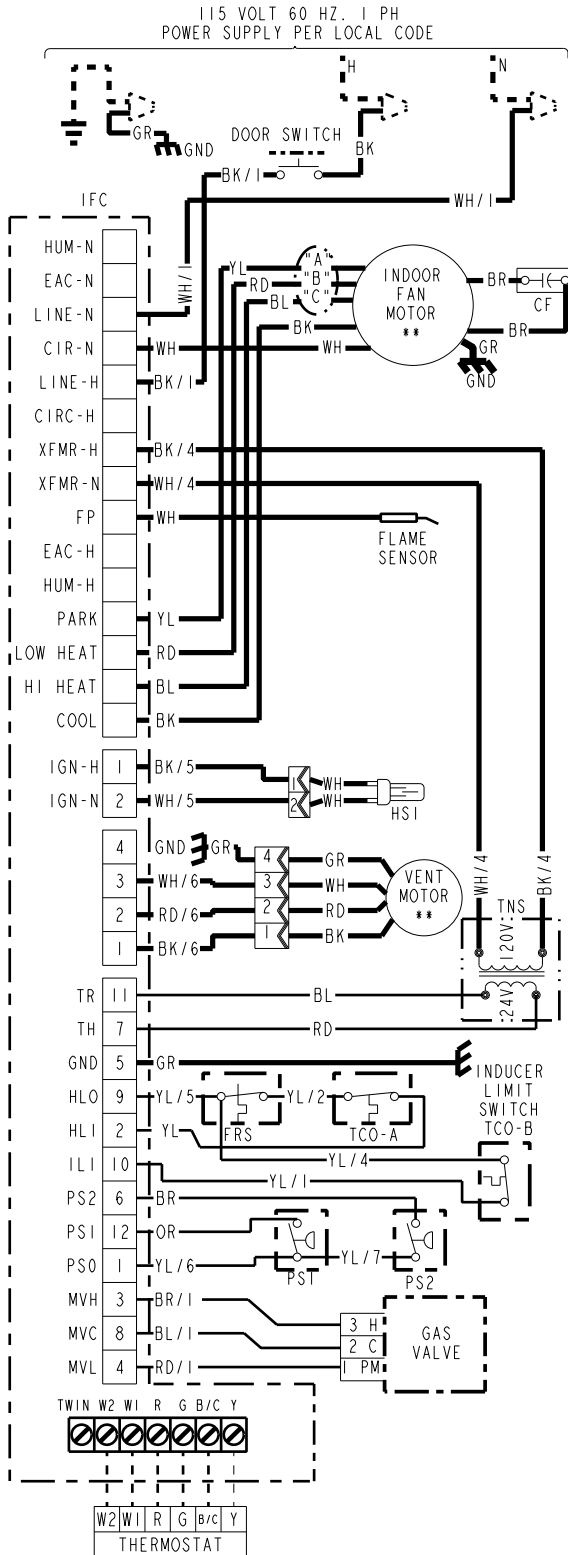

SEE NOTES 2, 3, 5, 7

DIAGNOSTIC CODES (SEE NOTE 8)

RED LED - LifePort Im Data - 1 Flash every 20 seconds	
2 FLASHES - SYSTEM LOCKOUT RETRIES OR RECYCLES EXCEEDED	6 FLASHES - 115 VOLT AC POWER REVERSED OR IGNITER FAULT
3 FLASHES - PRESSURE SWITCH FAULT	7 FLASHES - GAS VALVE CIRCUIT ERROR
4 FLASHES - OPEN LIMIT SWITCH	8 FLASHES - LOW FLAME SENSE SIGNAL
5 FLASHES - FLAME SENSED WHEN NO FLAME SHOULD BE PRESENT	9 FLASHES - OPEN INDUCER LIMIT
	10 FLASHES - INDUCER COMMUNICATION FAULT
	CONTINUOUS ON - INTERNAL CONTROL FAILURE
GREEN LED - STATUS	
SLOW FLASH - NORMAL, NO CALL FOR HEAT	
FAST FLASH - NORMAL, CALL FOR HEAT PRESENT	
GREEN AND RED LED'S ON CONTINUOUS - FUSE OPEN OR INTERNAL CONTROL FAILURE	

WARNING ⚠

HAZARDOUS VOLTAGE
DISCONNECT ALL ELECTRICAL POWER
INCLUDING REMOTE DISCONNECTS
BEFORE SERVICING.
FAILURE TO DISCONNECT POWER BEFORE
SERVICING CAN CAUSE SEVERE PERSONAL
INJURY OR DEATH.

CAUTION ⚠

USE COPPER CONDUCTORS ONLY!
UNIT TERMINALS ARE NOT DESIGNED
TO ACCEPT OTHER TYPES OF CONDUCTORS.
FAILURE TO DO SO MAY CAUSE DAMAGE
TO THE EQUIPMENT.

INTEGRATED FURNACE CONTROL

REPLACE WITH PART CNT 04677 OR EQUIVALENT
ELECTRICAL RATING
INPUT: 25 V.A.C., 60 HZ.
XFMR SEC. CURRENT: 450 MA. + MV LOAD
MV OUTPUT: 1.5 A @ 24 V.A.C.
IND OUTPUT: 3 PHASE OUTPUT
IGN OUTPUT: 2.0 A @ 120V.A.C.
CIRC. BLOWER OUTPUT: 14.5 FLA,
25 LRA @ 120 VAC
HUMIDIFIER & AIR CLEANER
MAX. LOAD: 1.0 A @ 120 VAC

TIMINGS
PREPURGE: 0 SEC.; INTERPURGE: 60 SEC.
POST PURGE: 5 SECONDS
IGNITOR WARMUP: 20 SECONDS
IAP: 3; TFI: 5 SECONDS
RETRIES: 2; RECYCLES: 10
HEAT ON DELAY: 45 SECONDS
COOL ON DELAY: 0 SECONDS
AUTO RESTART: 60 MINUTES
AUTO RESTART PURGE: 15 SECONDS

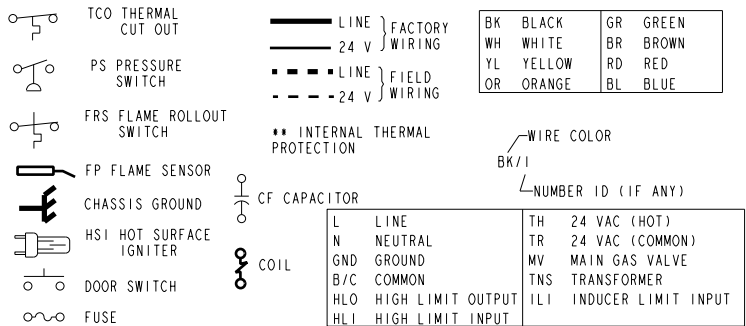

NOTES:

- IF ANY OF THE ORIGINAL WIRING AS SUPPLIED WITH THIS FURNACE MUST BE REPLACED, IT MUST BE WITH WIRE HAVING A TEMPERATURE RATING OF AT LEAST 105 C.
- THERMOSTAT HEAT ANTICIPATOR SETTING: FIRST STAGE .38 AMPS, SECOND STAGE .13 AMPS. IF SETTING IS NOT FIXED ON THERMOSTAT, FOR SINGLE STAGE HEATING THERMOSTAT SET AT .51 AMPS.
- FOR PROPER OPERATION OF COOLING SPEED, "Y" TERMINAL MUST BE CONNECTED TO THE ROOM THERMOSTAT.
- THESE LEADS PROVIDE 120V POWER CONNECTIONS FOR ELECTRONIC AIR CLEANER (EAC) AND HUMIDIFIER (HUM). MAX. LOAD: 1.0 AMPS EACH.
- JUMPER W1 AND W2 FOR SINGLE STAGE HEATING THERMOSTAT, SECOND STAGE WILL BE ENERGIZED, DELAYED PER STAGING DELAY SETTING.
- POWER MUST BE OFF WHEN DIP SWITCHES ARE SET.
- WHEN TWINNING TWO FURNACES, BOTH UNITS MUST BE CONNECTED TO THE SAME 115 VAC PHASE. CONNECT THE TWO UNITS 'TWIN' TERMINALS WITH 14 TO 22 AWG WIRE.
- ON POWER-UP, LAST FOUR FAULTS, IF ANY, WILL BE FLASHED ON RED LED. GREEN LED WILL BE SOLID ON DURING LAST FAULT RECOVERY.

Installer's Guide

KIT15018 Wiring diagram

DETAIL A			DETAIL B			
STAGING DELAY			HEAT "OFF" DELAY			
OFF SW1 ON	DS1	DS2	MIN.	DS1	DS2	DELAY
1	ON	OFF	0.5	ON	OFF	60 SEC
2	OFF	ON	5	ON	ON	100 SEC*
	OFF	OFF	10*	OFF	ON	140 SEC
	ON	ON	15	OFF	OFF	180 SEC

2 PIN CONNECTOR	
1.	IGN IGNITOR
2.	IGN-N IGNITOR-NEUTRAL

4 PIN CONNECTOR	
1.	INDUCER, PHASE 1
2.	INDUCER, PHASE 2
3.	INDUCER, PHASE 3
4.	NOT USED, (CONTROL END)

12 PIN CONNECTOR	
1.	PSO PRESSURE SWITCH OUTPUT
2.	HLI HIGH LIMIT INPUT
3.	MVH VALVE HIGH STAGE
4.	MVL VALVE LOW STAGE
5.	GND GROUND
6.	PS2 HPS INPUT
7.	TH 24VAC
8.	MVC VALVE COMMON
9.	HLO HIGH LIMIT OUTPUT
10.	ILI INDUCER LIMIT INPUT
11.	TR 24V RETURN
12.	PSI LPS INPUT

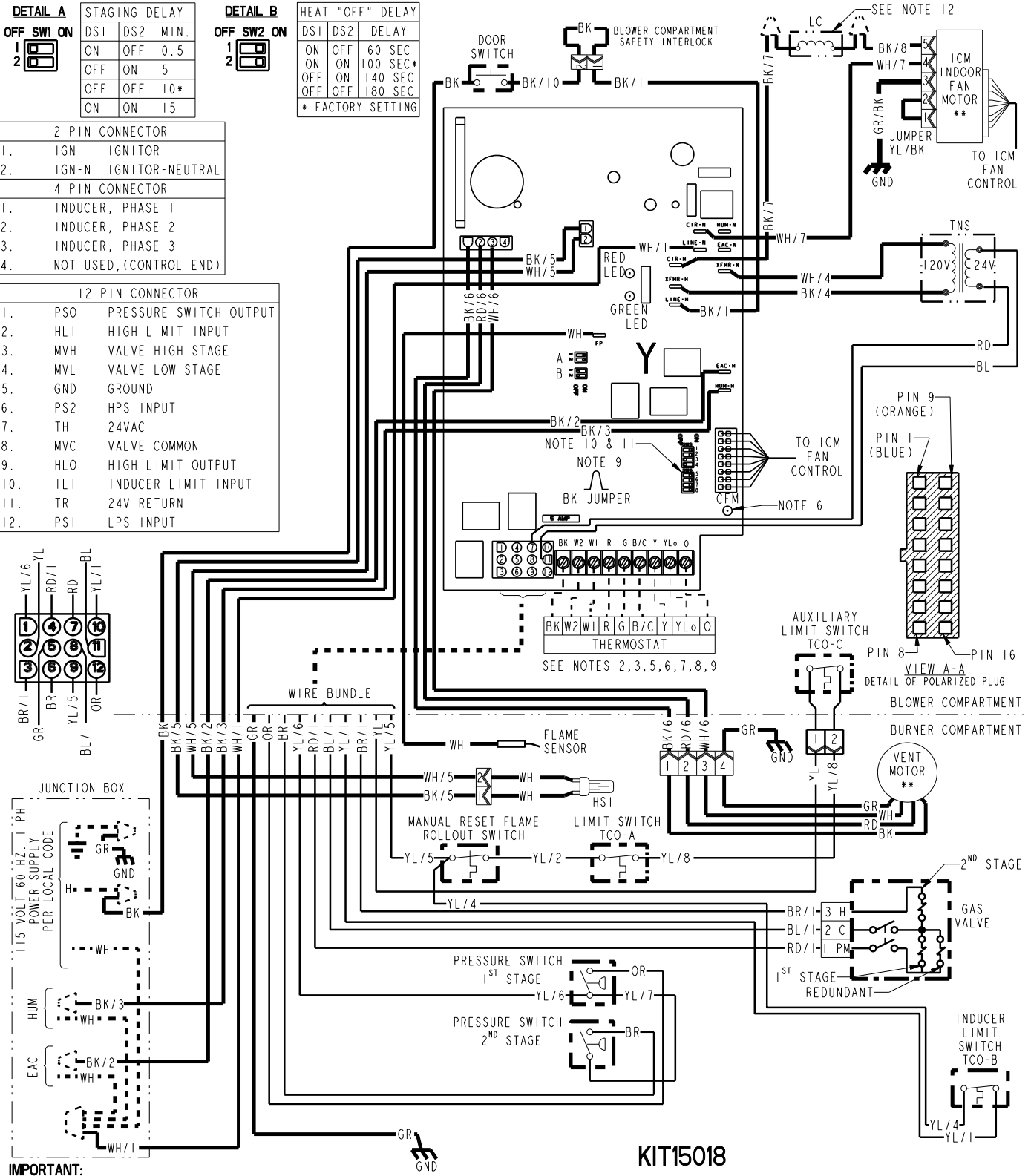

IMPORTANT:
 INTEGRATED CONTROL IS POLARITY SENSITIVE.
 HOT LEG OF 120V POWER SUPPLY MUST BE CONNECTED
 TO THE BLACK POWER LEAD AS INDICATED ON WIRING DIAGRAM.

KIT15018

KIT15018 Schematic

KIT15018

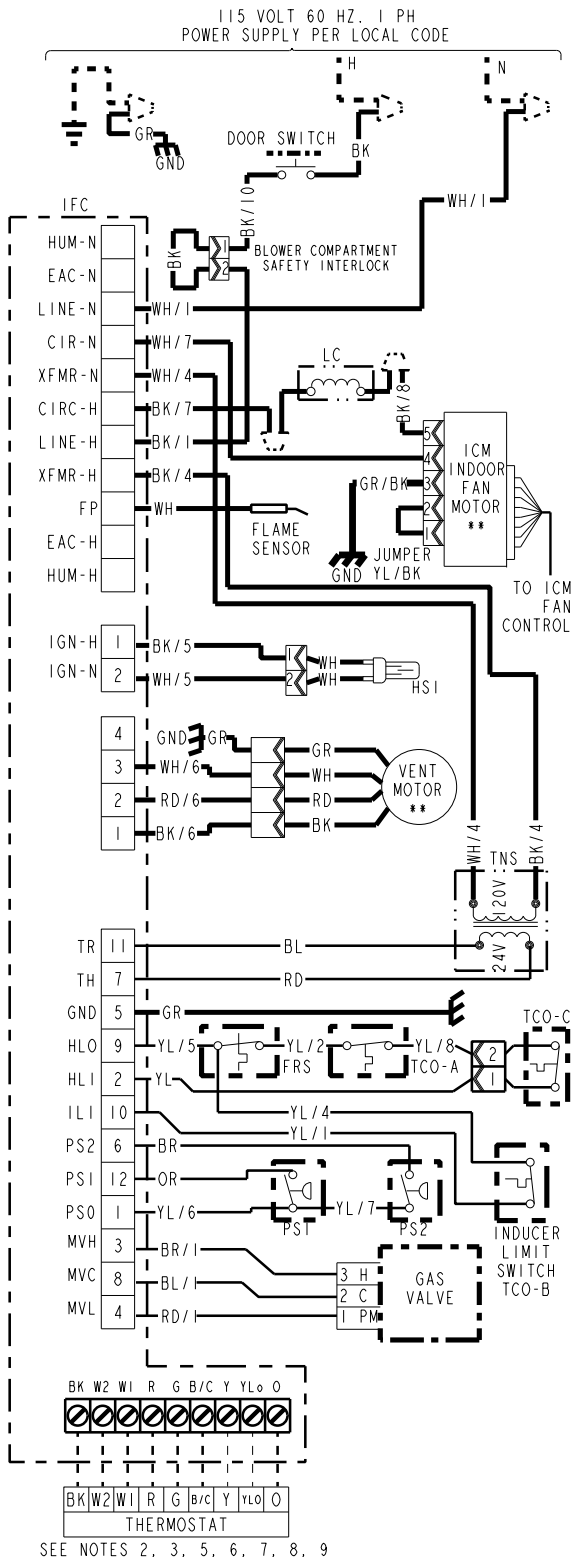

SEE NOTES 2, 3, 5, 6, 7, 8, 9

DIAGNOSTIC CODES (SEE NOTE 13)	
RED LED - LifePort™ Data - 1 Flash every 20 seconds	
2 FLASHES - SYSTEM LOCKOUT RETRIES OR RECYCLES EXCEEDED	6 FLASHES - 115 VOLT AC POWER REVERSED OR IGNITER FAULT
3 FLASHES - PRESSURE SWITCH FAULT	7 FLASHES - GAS VALVE CIRCUIT ERROR
4 FLASHES - OPEN LIMIT SWITCH	8 FLASHES - LOW FLAME SENSE SIGNAL
5 FLASHES - FLAME SENSED WHEN NO FLAME SHOULD BE PRESENT	9 FLASHES - OPEN INDUCER LIMIT
	10 FLASHES - INDUCER COMMUNICATION FAULT
CONTINUOUS ON - INTERNAL CONTROL FAILURE	
GREEN LED - STATUS	
SLOW FLASH - NORMAL, NO CALL FOR HEAT	
FAST FLASH - NORMAL, CALL FOR HEAT PRESENT	
GREEN AND RED LED'S ON CONTINUOUS - FUSE OPEN OR INTERNAL CONTROL FAILURE	

WARNING ⚠	CAUTION ⚠
HAZARDOUS VOLTAGE	USE COPPER CONDUCTORS ONLY!
DISCONNECT ALL ELECTRICAL POWER INCLUDING REMOTE DISCONNECTS BEFORE SERVICING.	UNIT TERMINALS ARE NOT DESIGNED TO ACCEPT OTHER TYPES OF CONDUCTORS.
FAILURE TO DISCONNECT POWER BEFORE SERVICING CAN CAUSE SEVERE PERSONAL INJURY OR DEATH.	FAILURE TO DO SO MAY CAUSE DAMAGE TO THE EQUIPMENT.

INTEGRATED FURNACE CONTROL

REPLACE WITH PART CNT 04678 OR EQUIVALENT
ELECTRICAL RATING
INPUT: 25 V.A.C., 60 HZ.
XFMR SEC. CURRENT: 450 MA. + MV LOAD
MV OUTPUT: 1.5 A @ 24 V.A.C.
IND OUTPUT: 3 PHASE OUTPUT
IGN OUTPUT: 2.0 A @ 120V.A.C.
CIRC. BLOWER OUTPUT: 14.5 FLA,
25 LRA @ 120 VAC
HUMIDIFIER & AIR CLEANER
MAX. LOAD: 1.0 A @ 120 VAC

TIMINGS
PREPURGE: 0 SEC.; INTERPURGE: 60 SEC.
POST PURGE: 5 SECONDS
IGNITOR WARMUP: 20 SECONDS
IAP: 3; TFI: 5 SECONDS
RETRIES: 2; RECYCLES: 10
HEAT ON DELAY: 45 SECONDS
COOL ON DELAY: 0 SECONDS
AUTO RESTART: 60 MINUTES
AUTO RESTART PURGE: 15 SECONDS

TCO THERMAL CUT OUT	— LINE } FACTORY WIRING	BK BLACK	GR GREEN
PS PRESSURE SWITCH	— 24 V }	WH WHITE	BR BROWN
FRS FLAME ROLLOUT SWITCH	- - - LINE } FIELD WIRING	YL YELLOW	RD RED
FP FLAME SENSOR	- - - 24 V }	OR ORANGE	BL BLUE
CHASSIS GROUND	** INTERNAL THERMAL PROTECTION	WIRE COLOR	
HSI HOT SURFACE IGNITER	CF CAPACITOR	BK/1 NUMBER ID (IF ANY)	
DOOR SWITCH	COIL		
FUSE			

L	LINE	TH	24 VAC (HOT)
N	NEUTRAL	TR	24 VAC (COMMON)
GND	GROUND	MV	MAIN GAS VALVE
B/C	COMMON	TNS	TRANSFORMER
HLO	HIGH LIMIT OUTPUT	ILI	INDUCER LIMIT INPUT
HLI	HIGH LIMIT INPUT		

NOTES:

- IF ANY OF THE ORIGINAL WIRING AS SUPPLIED WITH THIS FURNACE MUST BE REPLACED, IT MUST BE WITH WIRE HAVING A TEMPERATURE RATING OF AT LEAST 105 C.
- THERMOSTAT HEAT ANTICIPATOR SETTING: FIRST STAGE .38 AMPS, SECOND STAGE .13 AMPS. IF SETTING IS NOT FIXED ON THERMOSTAT, FOR SINGLE STAGE HEATING THERMOSTAT SET AT .51 AMPS.
- FOR PROPER OPERATION OF COOLING SPEED, "Y" TERMINAL MUST BE CONNECTED TO THE ROOM THERMOSTAT.
- THESE LEADS PROVIDE 120V POWER CONNECTIONS FOR ELECTRONIC AIR CLEANER (EAC) AND HUMIDIFIER (HUM). MAX. LOAD: 1.0 AMPS EACH.
- JUMPER W1 AND W2 FOR SINGLE STAGE HEATING THERMOSTAT, SECOND STAGE WILL BE ENERGIZED, DELAYED PER STAGING DELAY SETTING.
- GREEN LIGHT (CFM) FLASHES ONCE PER 100 CFM COMMAND.
- FOR HEAT PUMP SYSTEMS Y AND O MUST BE CONNECTED TO THE LOW-VOLTAGE TERMINAL BOARD.
- FOR TWO SPEED SYSTEMS, USE YLO FOR LOW SPEED AND Y FOR HIGH SPEED CONNECTION TO THE LOW-VOLTAGE TERMINAL BOARD.
- OPTIONAL HUMIDSTAT IS TO BE CONNECTED BETWEEN THE "R" AND "BK". FACTORY INSTALLED JUMPER "R" TO "BK" (BK JUMPER) ON THE CIRCUIT BOARD MUST BE CUT IF OPTIONAL HUMIDSTAT IS USED. THE JUMPER MUST ALSO BE CUT WHEN APPLYING AN AIRFLOW COMMAND SIGNAL TO THE "BK" INPUT SUCH AS WITH THE VARIABLE SPEED SINGLE-ZONE AND MULTI-ZONE SYSTEM CONTROLLERS. ON SINGLE SPEED COOLING ONLY / NON-HEAT PUMP SYSTEMS, JUMPER "Y" TO "O" FOR PROPER OPERATION OF THE DELAY PROFILES AND THE HUMIDSTAT. FOR TWO COMPRESSOR OR TWO SPEED SYSTEMS, JUMPER "YLO" TO "O".
- SEE INDOOR MOTOR AIRFLOW SELECTION CHART, LOCATED IN THE FURNACE FOR DIP SWITCH SETTINGS TO SET AIRFLOW AND COOLING OFF DELAYS.
- POWER MUST BE OFF WHEN DIP SWITCHES ARE SET.
- USED FOR 100,000 BTU/HR AND 120,000 BTU/HR MODELS ONLY.
- ON POWER-UP, LAST FOUR FAULTS, IF ANY, WILL BE FLASHED ON RED LED. GREEN LED WILL BE SOLID ON DURING LAST FAULT RECOVERY.

From Drawing D343217P02

Installer's Guide

KIT15020 Wiring diagram

DETAIL A
OFF SW1 ON

STAGING DELAY	DS1	DS2	MIN.
ON	ON	OFF	0.5
OFF	ON	ON	5
OFF	OFF	OFF	10*
ON	ON	ON	15

DETAIL B
OFF SW2 ON

HEAT "OFF" DELAY	DS1	DS2	DELAY
ON	ON	OFF	60 SEC
ON	ON	ON	100 SEC*
OFF	ON	OFF	140 SEC
OFF	OFF	OFF	180 SEC

* FACTORY SETTING

DS3	COOL OFF DELAY
ON	0 SECONDS*
OFF	80 SECONDS

2 PIN CONNECTOR	
1.	IGN IGNITOR
2.	IGN-N IGNITOR-NEUTRAL

4 PIN CONNECTOR	
1.	INDUCER, PHASE 1
2.	INDUCER, PHASE 2
3.	INDUCER, PHASE 3
4.	NOT USED, (CONTROL END)

12 PIN CONNECTOR	
1.	PSO PRESSURE SWITCH OUTPUT
2.	HLI HIGH LIMIT INPUT
3.	MVH VALVE HIGH STAGE
4.	MVL VALVE LOW STAGE
5.	GND GROUND
6.	PS2 HPS INPUT
7.	TH 24VAC
8.	MVC VALVE COMMON
9.	HLO HIGH LIMIT OUTPUT
10.	ILI INDUCER LIMIT INPUT
11.	TR 24V RETURN
12.	PSI LPS INPUT

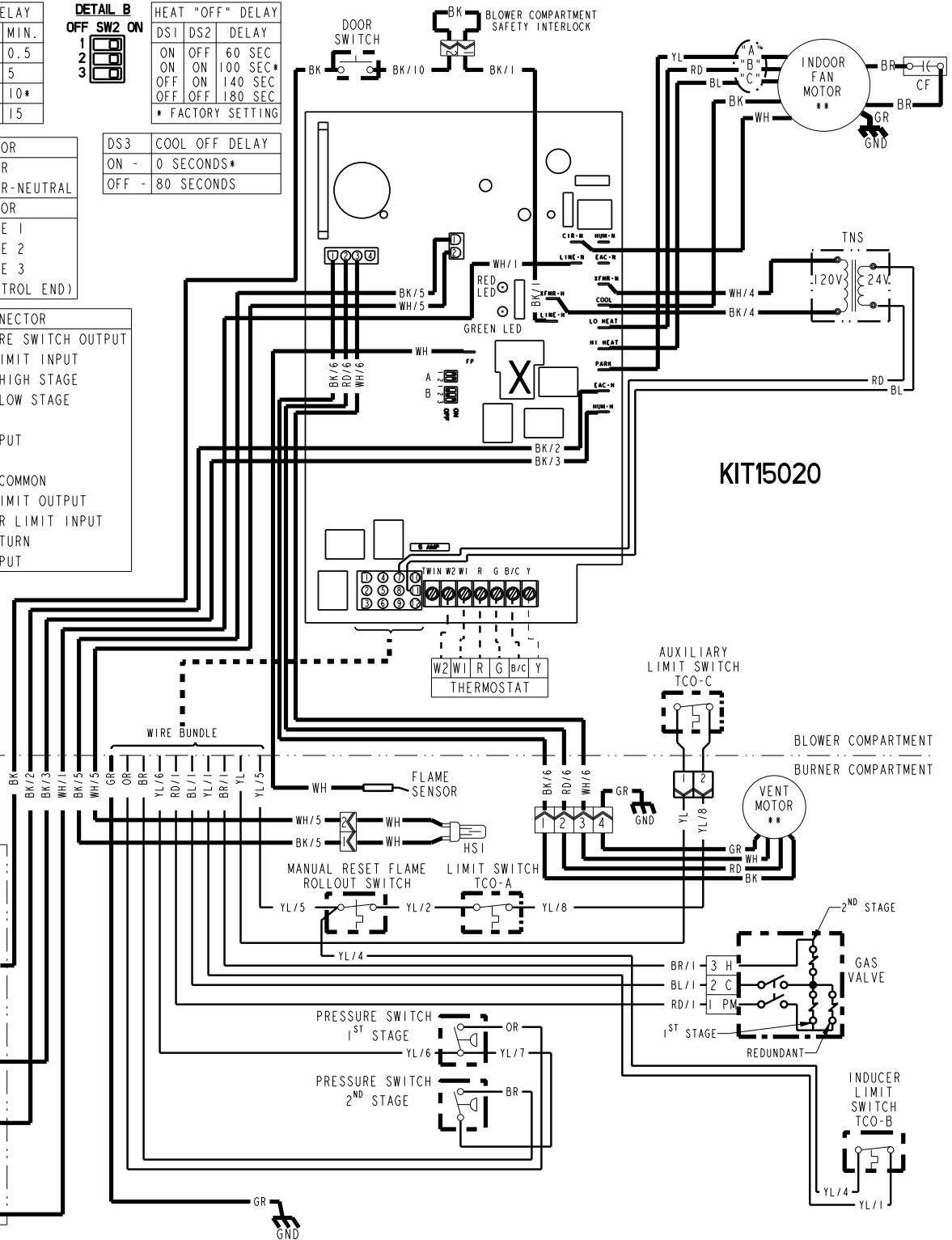
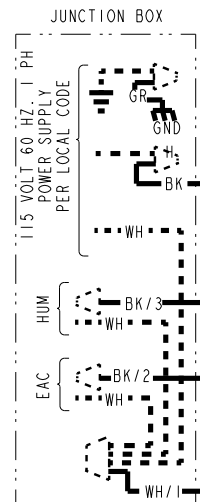
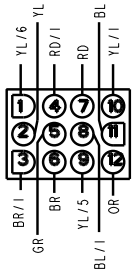

IMPORTANT:
INTEGRATED CONTROL IS POLARITY SENSITIVE.
HOT LEG OF 120V POWER SUPPLY MUST BE CONNECTED
TO THE BLACK POWER LEAD AS INDICATED ON WIRING DIAGRAM.

KIT15020 Schematic

KIT15020

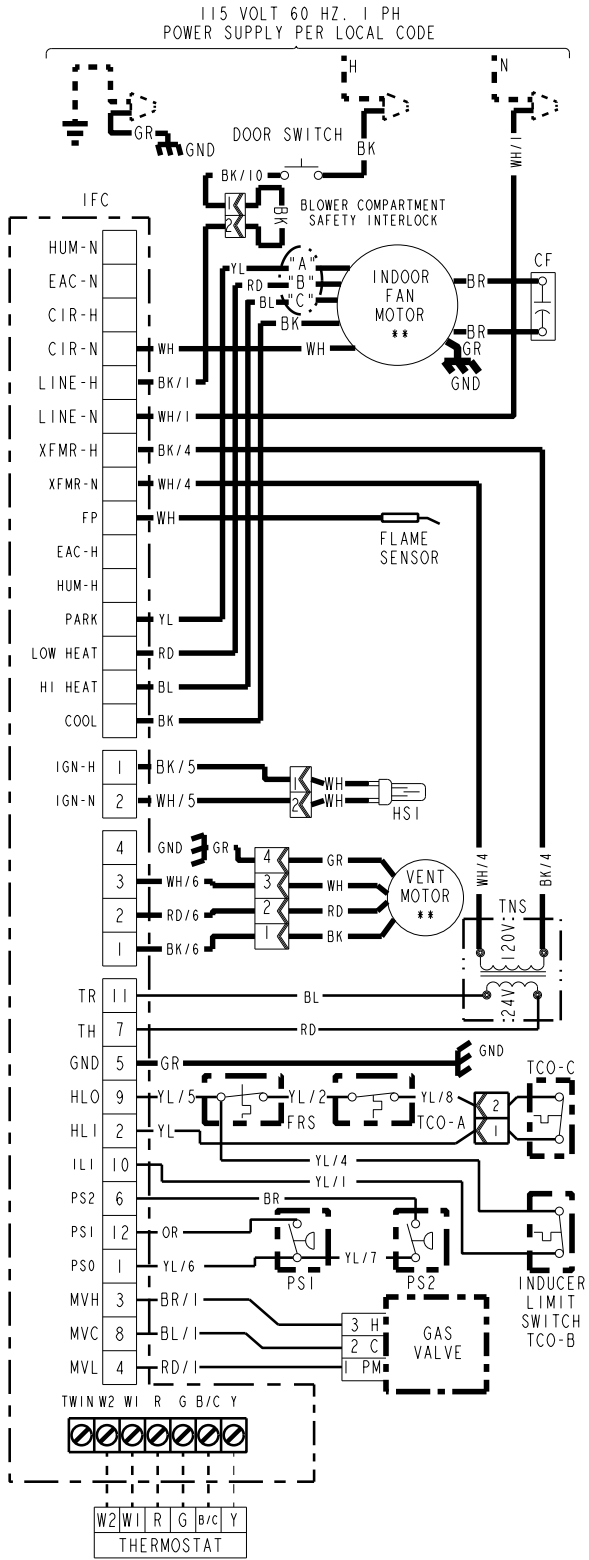

SEE NOTES 2, 3, 5, 7

DIAGNOSTIC CODES (SEE NOTE 8)	
RED LED - LifePort tm Data - 1 Flash every 20 seconds	
2 FLASHES - SYSTEM LOCKOUT RETRIES OR RECYCLES EXCEEDED	6 FLASHES - 115 VOLT AC POWER REVERSED OR IGNITER FAULT
3 FLASHES - PRESSURE SWITCH FAULT	7 FLASHES - GAS VALVE CIRCUIT ERROR
4 FLASHES - OPEN LIMIT SWITCH	8 FLASHES - LOW FLAME SENSE SIGNAL
5 FLASHES - FLAME SENSED WHEN NO FLAME SHOULD BE PRESENT	9 FLASHES - OPEN INDUCER LIMIT
	10 FLASHES - INDUCER COMMUNICATION FAULT
	CONTINUOUS ON - INTERNAL CONTROL FAILURE
GREEN LED - STATUS	
SLOW FLASH - NORMAL, NO CALL FOR HEAT	
FAST FLASH - NORMAL, CALL FOR HEAT PRESENT	
GREEN AND RED LED'S ON CONTINUOUS - FUSE OPEN OR INTERNAL CONTROL FAILURE	

WARNING ⚠	CAUTION ⚠
HAZARDOUS VOLTAGE	USE COPPER CONDUCTORS ONLY!
DISCONNECT ALL ELECTRICAL POWER INCLUDING REMOTE DISCONNECTS BEFORE SERVICING.	UNIT TERMINALS ARE NOT DESIGNED TO ACCEPT OTHER TYPES OF CONDUCTORS.
FAILURE TO DISCONNECT POWER BEFORE SERVICING CAN CAUSE SEVERE PERSONAL INJURY OR DEATH.	FAILURE TO DO SO MAY CAUSE DAMAGE TO THE EQUIPMENT.

INTEGRATED FURNACE CONTROL

REPLACE WITH PART CNT 04677 OR EQUIVALENT
 ELECTRICAL RATING
 INPUT: 25 V.A.C., 60 HZ.
 XFMR SEC. CURRENT: 450 MA. + MV LOAD
 MV OUTPUT: 1.5 A @ 24 V.A.C.
 IND OUTPUT: 3 PHASE OUTPUT
 IGN OUTPUT: 2.0 A @ 120V.A.C.
 CIRC. BLOWER OUTPUT: 14.5 FLA,
 25 LRA @ 120 VAC
 HUMIDIFIER & AIR CLEANER
 MAX. LOAD: 1.0 A @ 120 VAC

TIMINGS

PREPURGE: 0 SEC.; INTERPURGE: 60 SEC.
 POST PURGE: 5 SECONDS
 IGNITOR WARMUP: 20 SECONDS
 IAP: 3; TFI: 5 SECONDS
 RETRIES: 2; RECYCLES: 10
 HEAT ON DELAY: 45 SECONDS
 COOL ON DELAY: 0 SECONDS
 AUTO RESTART: 60 MINUTES
 AUTO RESTART PURGE: 15 SECONDS

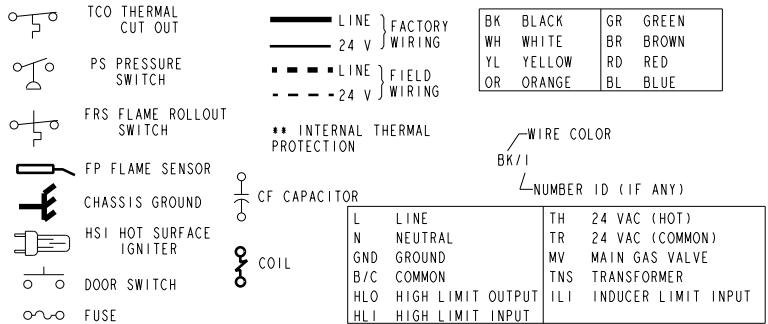

NOTES:

- IF ANY OF THE ORIGINAL WIRING AS SUPPLIED WITH THIS FURNACE MUST BE REPLACED, IT MUST BE WITH WIRE HAVING A TEMPERATURE RATING OF AT LEAST 105 C.
- THERMOSTAT HEAT ANTICIPATOR SETTING: FIRST STAGE .38 AMPS, SECOND STAGE .13 AMPS. IF SETTING IS NOT FIXED ON THERMOSTAT, FOR SINGLE STAGE HEATING THERMOSTAT SET AT .51 AMPS.
- FOR PROPER OPERATION OF COOLING SPEED, "Y" TERMINAL MUST BE CONNECTED TO THE ROOM THERMOSTAT.
- THESE LEADS PROVIDE 120V POWER CONNECTIONS FOR ELECTRONIC AIR CLEANER (EAC) AND HUMIDIFIER (HUM). MAX. LOAD: 1.0 AMPS EACH.
- JUMPER W1 AND W2 FOR SINGLE STAGE HEATING THERMOSTAT, SECOND STAGE WILL BE ENERGIZED, DELAYED PER STAGING DELAY SETTING.
- POWER MUST BE OFF WHEN DIP SWITCHES ARE SET.
- WHEN TWINNING TWO FURNACES, BOTH UNITS MUST BE CONNECTED TO THE SAME 115 VAC PHASE. CONNECT THE TWO UNITS 'TWIN' TERMINALS WITH 14 TO 22 AWG WIRE.
- ON POWER-UP, LAST FOUR FAULTS, IF ANY, WILL BE FLASHED ON RED LED. GREEN LED WILL BE SOLID ON DURING LAST FAULT RECOVERY.

From Drawing D343217P04

Installer's Guide ---

Trane U.S. Inc.
6200 Troup Highway
Tyler, TX 75707

*For more information contact
your local dealer (distributor)*

Literature Order Number	18-CH41D1-1
File Number	18-CH41D1-1
Supersedes	New
Stocking Location	---

01/08

Since the manufacturer has a policy of continuous product and product data improvement, it reserves the right to change design and specifications without notice.