



# READ COMPLETE SAFETY INSTRUCTIONS, PRE-INSTALLATION SETUP AND CHECKOUT PROCEDURE FOR BYPASS HUMIDIFIER AND INSTALLATION/TEMPLATE INSTRUCTIONS BEFORE STARTING

## ATTENTION INSTALLER:

This product must be installed by a qualified heating and air conditioning contractor. Failure to do so could result in serious injury from electrical shock. This product must be installed in compliance with all local, state and federal codes.

# BYPASS HUMIDIFIER MODEL EHUMD300A

### WARNING

#### 1. ELECTRICAL SHOCK HAZARD.

Disconnect electrical power to the furnace before starting installation. Failure to do so could result in serious injury from electrical shock.

**2. SHARP EDGES HAZARD.** Sharp edges may cause serious injury from cuts. Use care when making plenum openings and handling ductwork. Use personal protective equipment when installing HVAC equipment.

**3. RISK OF SCALDING.** Water temperature over 125°F can cause severe burns and scald instantly. Shut off the hot water supply before disconnecting or tapping into any hot water supply line.

### CAUTION

#### RISK OF PROPERTY AND EQUIPMENT DAMAGE.

1. Do not install in attic or crawl areas.

2. Do not install humidifier where freezing temperatures could occur. The water line could freeze and crack causing water damage to the home.

3. Do not install humidifier or bypass connection on the furnace cabinet.

4. Do not install humidifier or bypass connection on a plenum face where the blanked off ends of the cooling coil will restrict air movement through the humidifier.

5. Do not set humidity level above recommended or to recommended level if condensation exists on inside windows of any unheated space, as condensation damage may result. Excess humidity can cause moisture accumulation which can allow the possibility for mold growth in the home.

6. Do not connect humidifier transformer to blower motor wiring. Premature component failure may result.

7. When installing Humidifier Control on downflow furnace, ensure blower continues to run after a heat call is satisfied to eliminate high temperatures from damaging the Control.

8. Do not install humidifier where water pressure exceeds 125 psi, since damage to the humidifier may result. Follow codes in effect concerning pressure reduction.

9. Do not install humidifier on the supply plenum where static pressure exceeds 0.2" W.C.

### SPECIFICATIONS

#### HUMIDIFIER DIMENSIONS

Width (including solenoid valve): 15 3/8"  
Height (including drain spud): 15 3/4"  
Depth: 10 1/4"

#### BYPASS DUCT OPENING

6" diameter

#### PLENUM OPENING

10"W x 12 3/4"H

#### WATER FEED RATE

3 gph

#### ELECTRICAL DATA

24 VAC-60 Hz, 0.5 AMP

## WIRING DIAGRAM

(SEE "INSTALLER'S GUIDE / AUTOMATIC HUMIDIFIER CONTROL, FORM #18-CH31D1-3" FOR DETAILED WIRING INSTRUCTIONS)

**NOTE:** FOR COMMUNICATING SYSTEM WIRING DIAGRAMS, SEE ENCLOSED INSTALLER'S GUIDE, FORM 18-HE87D1-3.

### NOTE

VERIFY THAT SWITCH IS IN THE "BYPASS" POSITION.

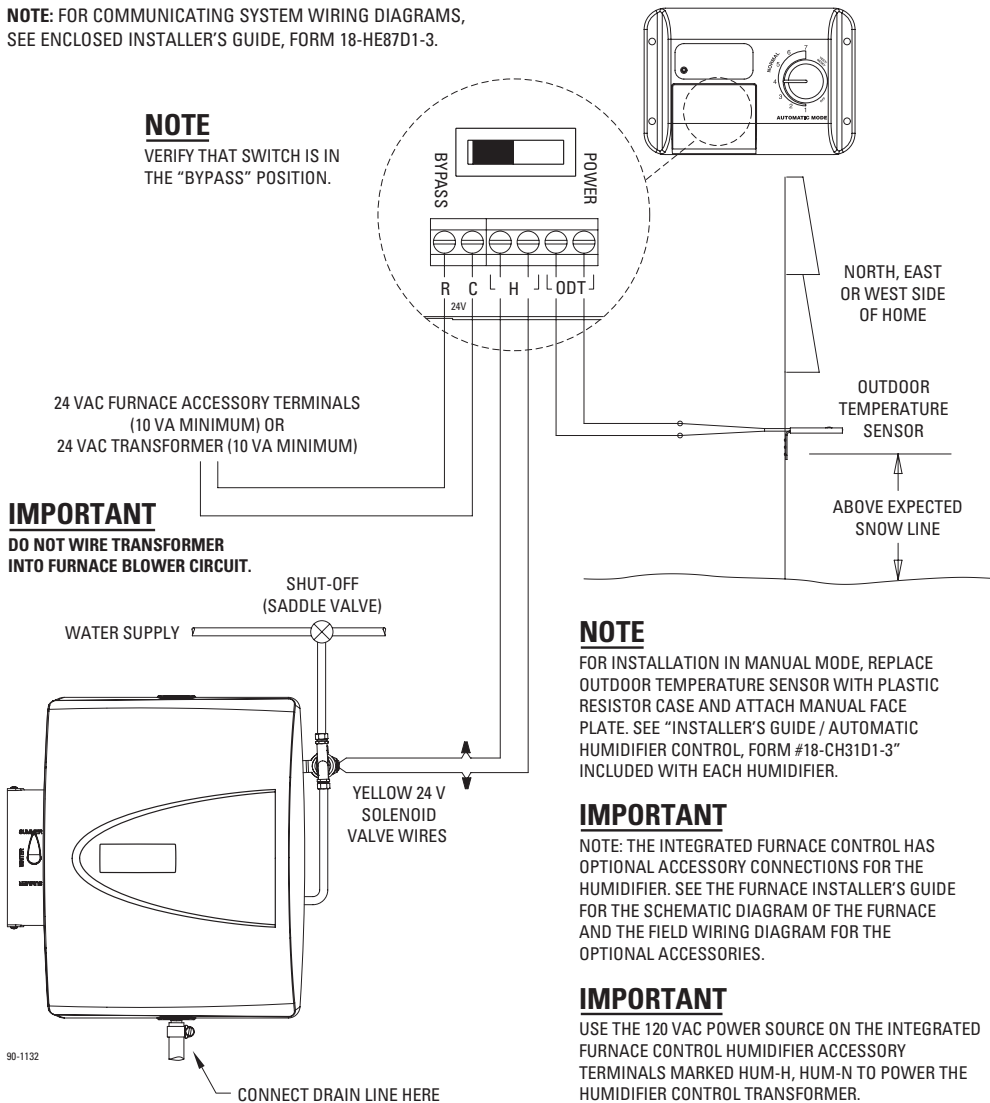

## INSTALLATION OPTIONS

The humidifier can be installed on either the supply or return plenum of a forced air handling system and is easily reversible for installation with right hand or left hand bypass duct connections. The humidifier dimensions and serviceability must be considered when selecting the best location for the humidifier.

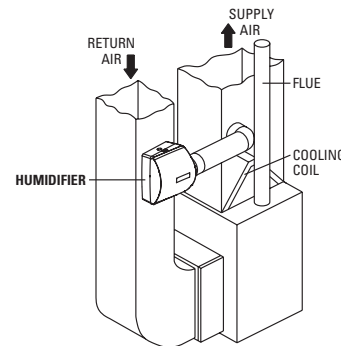

**Upflow Furnace**  
OPTION "A" REAR OF FURNACE OR REAR MOUNT

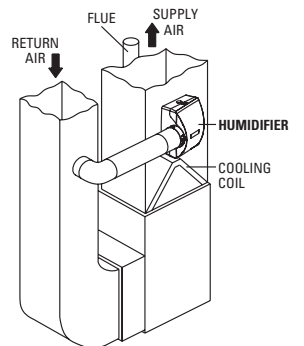

**Upflow Furnace**  
OPTION "B" FRONT OF FURNACE OR FRONT MOUNT

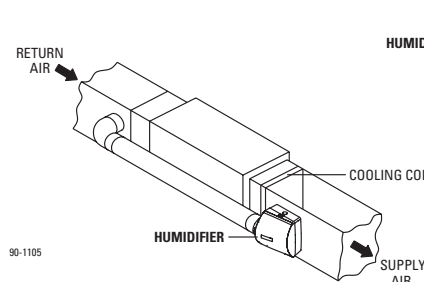

**Horizontal Furnace**

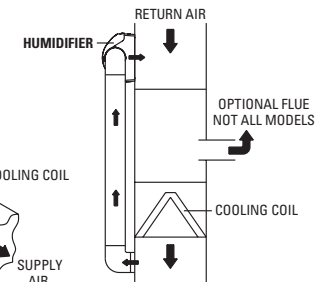

**Downflow Furnace**

Trane  
Ingersoll Rand  
6200 Troup Highway  
Tyler, TX 75711-9010

**TEMPLATE MUST BE LEVEL**

**READ REVERSE SIDE FIRST!**

**- TOP -**

**READ REVERSE SIDE FIRST!**

**READ COMPLETE SAFETY INSTRUCTIONS AND INSTALLATION TEMPLATE BEFORE STARTING**

FURNISHED ITEMS
Built-in bypass damper
24 VAC Transformer
Automatic Humidifier Control
Automatic Humidifier Control Installation Sheet
Saddle valve
Humidifier Installation Template
ITEMS NOT FURNISHED
Mounting screws (sheet metal screws)
Water supply line (1/4" copper)
Drain line (1/2" I.D. hose)
Low voltage wire
Bypass ductwork
Current Sensing Relay Part No. BAYRLY10ASENSA (if required)

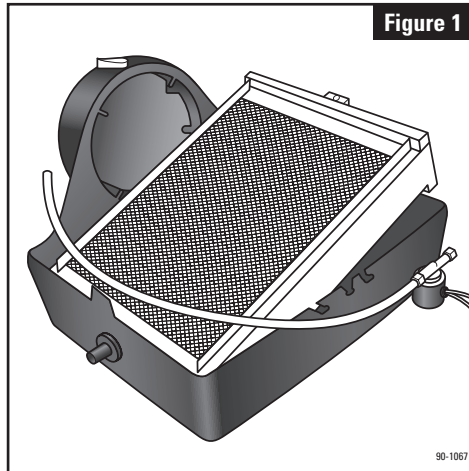

Figure 1

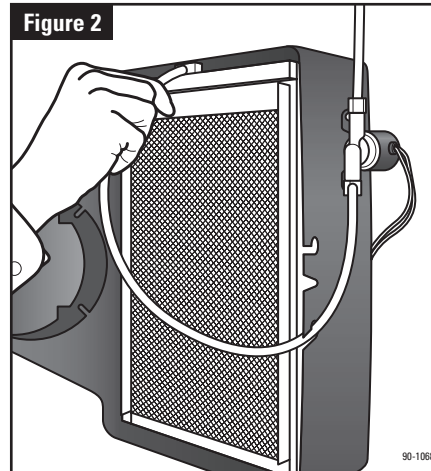

Figure 2

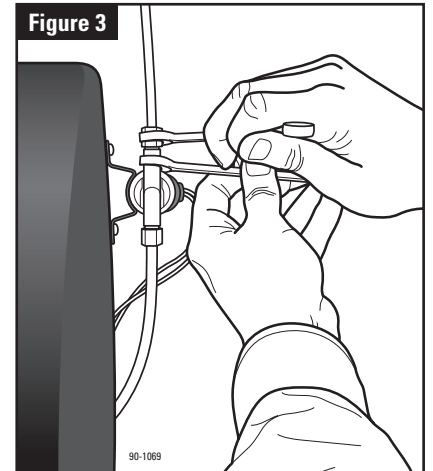

Figure 3

**1.** Remove front cover by pressing center tabs on top and bottom of the cover (1) and base (2). Pull feed tube (3) out of the water distribution tray (4). Tip the evaporative assembly forward and lift it out of the humidifier. (See Figure 1)

**2.** The humidifier comes assembled for left side discharge. If converting to right side discharge, the base can be rotated so round collar is facing to the right. Swap the location of the hole plug (10) and drain spud (9) if using a right side discharge. To remove the cap, push and twist from inside the housing while lifting the cap up slightly on the outside. To remove the drain spud, twist and push from the outside of the base.

**3.** Using a level, position this template at least 3 inches above the furnace housing or cooling coil, if applicable, for clearance of the drain line. Trace around template edges. Remove the template and accurately cut the plenum opening 10"W x 12 3/4"H, being careful to avoid injury from sharp edges.

**4.** Place the humidifier into the plenum opening, install six sheet metal mounting screws (not furnished) at the top and sides of the humidifier interior.

**5.** Install a 6" collar in a convenient location on the opposite plenum. Attach a 90° elbow and measure the length of 6" round duct required to make the connection. The design of the humidifier collar provides a solid connection with the bypass duct through the use of inside support ribs and pre-formed holes for sheet metal screws. Slip the duct inside the collar of the humidifier, up to the support ribs. Using the pre-formed holes at the top and bottom of the humidifier collar, secure the duct to the humidifier collar with two sheet metal mounting screws (not furnished). Support bypass ducts longer than 4 feet to prevent sagging.

**6.** Reinstall the evaporative assembly back into the base, with the bottom of the scale control insert (6) sitting firmly in the inside of the drain spud (9). Push the feed tube back into the

water distribution tray. (See Figure 2) Put the front cover back on. If the nameplate (11) is upside down, remove it and rotate the nameplate so it is right side up, and snap back into place. Turn damper handle (8) to the open position "WINTER" for the heating season, or closed position "SUMMER" for the cooling season.

**7.** Install the Automatic Humidifier Control in the return duct using the installation instructions enclosed (see Wiring Diagram, opposite side). For detailed installation and wiring instructions, see "Installer's Guide/Automatic Humidifier Control, Form #18-CH31D1-3" included with the humidifier.

**8.** The Automatic Humidifier Control must be powered by a 24 VAC power source connected to the "R" and "C" terminals on the Control. The 24 VAC humidifier solenoid valve receives power through the Control. Connect the yellow wires to the "H" terminals on the Control. **Do not connect yellow wires to accessory terminals on furnace or damage to the humidifier could result.**

In order for the humidifier to turn on, the furnace blower must be operating and the control must be calling for humidity. The interface between the humidifier and the furnace to detect blower operation can be accomplished several different ways:

**A.** If the Control is powered directly from 24 VAC accessory terminals on the furnace, which are activated only during furnace blower operation or a heat call, then the yellow wires from the humidifier can be connected directly to the "H" terminals on the Control.

**B.** If the Control is powered by a transformer connected to 120 VAC "HUM" terminals on the furnace, which are activated only during furnace blower operation or a heat call, then the yellow wires from the humidifier can be connected directly to the "H" terminals on the Control.

**C.** If the Control is powered from a continuous 24 VAC source, then a Current Sensing Relay Part No. BAYRLY10ASENSA (not included) must be installed in the humidifier circuit. (Yellow wires connected to "H" terminals on Control.)

**Do not wire transformer into furnace blower circuit.** The transformer can be powered from the 120 VAC line before it enters the furnace.

**9.** Tap into a water supply line with the saddle valve furnished. See instructions on saddle valve package. The humidifier will function with cold, hot, softened or unsoftened water. The use of service hot water (140°F MAX.) and constant blower operation will provide maximum evaporative capacity. **When installing humidifier on heat pump system, humidifier must be supplied with service hot water.**

**NOTE: The saddle valve is designed to be fully opened or closed. Do not use it to regulate water flow.**

**10.** Connect tubing from the saddle valve to the inlet side of the solenoid valve using 1/4" O.D. copper tubing (not furnished). **DOUBLE WRENCH TO PREVENT LEAKING!** (See Figure 3)

**11.** Drain spud is designed to accept 1/2" I.D. plastic hose (not furnished). Run drain line from drain spud to floor drain. **CAUTION: If hose clamp is used, do not over tighten, drain spud could crack. Be sure drain line has continuous slope. NOTE: Do not sweat or directly attach metal drain line to fitting. Do not use solvent type adhesive when connecting plastic drain line, since damage to fitting could result.**

**12.** Open saddle valve completely and turn on furnace. Turn up humidifier control so that humidifier will turn on. Allow humidifier to run until water is observed coming out of the drain line. Check to see if humidifier and saddle valve are watertight. Check operation to make sure that all electrical components function properly by utilizing humidification system check-out section in the "Installer's Guide/Automatic Humidifier Control, Form #18-CH31D1-3". Set humidifier control to level recommended in the "Use and Care manual".

## PARTS LIST

- Front Cover
- Base
- Feed Tube
- Water Distribution Tray
- Humidifier Pad
- Scale Control Insert
- Integral Damper
- Damper Handle
- Drain Spud
- Hole Plug
- Nameplate
- Solenoid Valve

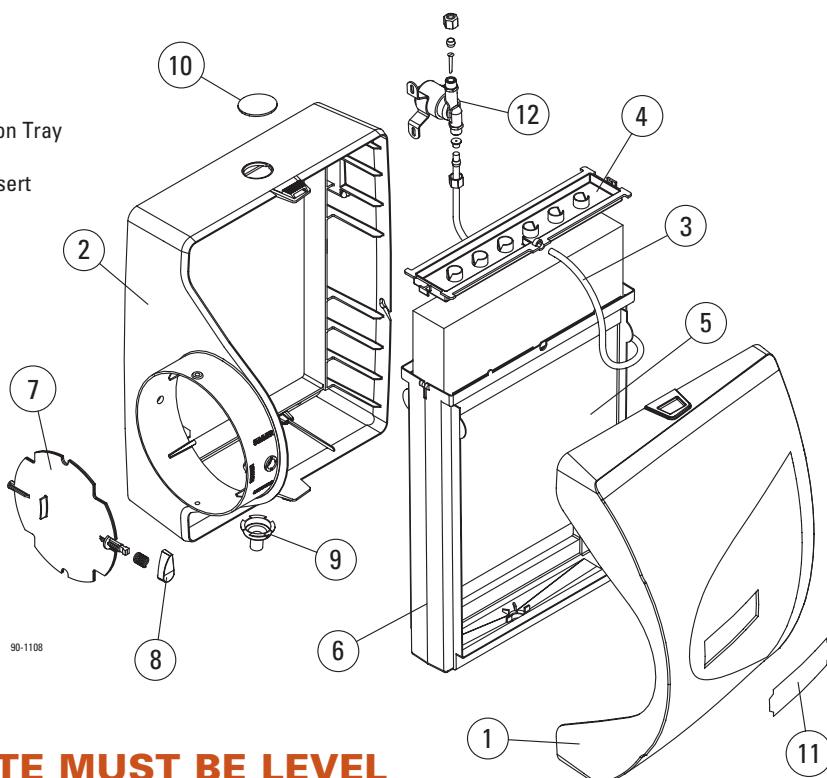

**NOTE: BEFORE LEAVING THE JOB SITE, MAKE SURE:**

- Saddle valve is fully open.
- All plumbing connections are watertight.
- Humidifier functions properly.
- Bypass damper is in proper position.

**IMPORTANT!** Be sure Use and Care manual containing instructions for operation and warranty information is given to owner in order to avoid unnecessary calls. Warranty is void unless humidifier is installed by qualified heating and air conditioning contractor due to possible misapplication of product.

**TEMPLATE MUST BE LEVEL**