

Installer's Guide

18-CH12D16-10A-EN



Available in French Canadian (FC)

BAYLPKT210B

Propane Conversion Kit for 1 and 2 Stage Furnaces

ALL phases of this installation must comply with NATIONAL, STATE AND LOCAL CODES

IMPORTANT—This Document is **customer property** and is to remain with this unit. Please return to service information pack upon completion of work.

⚠ WARNING

This conversion kit shall be installed by a qualified service agency in accordance with manufacturer's instructions and all applicable codes and requirements of the authority having jurisdiction. If the information in these instructions is not followed exactly, a fire, explosion or production of carbon monoxide may result causing property damage, personal injury or loss of life. The qualified service agency is responsible for the proper installation of the kit. The installation is not proper and complete until the operation of the converted furnace is checked as specified in the manufacturer's instructions supplied with the kit.

⚠ WARNING

EXPLOSION HAZARD

Propane gas is heavier than air and may collect in any low areas or confined spaces. In addition, odorant fade may make the gas undetectable except with a warning device. If the gas furnace is installed in a basement, an excavated area, or confined space, it is strongly recommended to contact a gas supplier to install a gas detecting warning device in case of a leak. Failure to follow this warning could result in serious personal injury, property damage, or death. The manufacturer of your furnace does not test any detectors and makes no representations regarding any brand of detector.

A. GENERAL

These instructions describe converting gas furnaces from natural gas to Propane gas.

Conversion from natural gas to Propane gas is a critical procedure, therefore, these INSTRUCTIONS MUST BE FOLLOWED CLOSELY.

B. INSPECTION

1. Unpack all components of the Propane conversion kit.

PROPANE ORIFICE		
MODELS IN 1000's BTUH	QUANTITY OF ORIFICE	ORIFICE SIZE
40	2	56
60	3	56
65, 80	4	56
85, 100	5	56
110, 120	6	56
140	7	56

EACH KIT CONTAINS:		Part Number
7	Orifice Main Burner #56	B138253P33
1	LP Spring Conversion Kit - KIT02851 (White-Rodgers Kit #92-0659)	A138928P01
1	Propane Label	B342003P02
1	Conversion Label	B342003P02
1	Conversion Responsibility Label	B342003P02
1	Installer's Guide	18-CH12D16-10A-EN

2. Check carefully for any shipping damage. If any damage is found, this must be reported immediately and a claim made against the transportation company.
3. Check to be sure all components are in the package. Any missing components should be reported to your supplier at once and replaced with authorized components only.

⚠ WARNING

Replace and/or tighten all plugs removed or loosened when adjusting gas pressure. Leak check the fittings before placing the furnace into regular service. Failure to follow this warning could result in fire, explosion or property damage.

C. CONVERSION INSTRUCTIONS:

***UD1, *DD1, *UE1, *DE1, and M80 Models**

⚠ CAUTION

The gas supply must be shut off and the electrical power disconnected before proceeding with the conversion.

1. Remove the top burner bracket (2 screws).
2. Remove all burners.

⚠ CAUTION

When removing extreme right burner, use caution not to break the ignitor assembly.

3. Remove all the main burner natural gas orifice(s).
4. Re-install the #56 propane orifice to the same depth as the orifices supplied with the equipment.
5. Replace all burners.

⚠ CAUTION

Check the ignitor alignment when replacing extreme right burner, use caution not to break the ignitor assembly.

6. Replace the top burner bracket (2 screws).
7. Remove the natural gas regulator spring from the gas valve and replace with the propane spring in the conversion kit. Apply labels to the gas valve per instructions with spring.
8. Apply "PROPANE" label to the rating plate of the furnace.
9. Apply Conversion label to the front of the furnace.
10. Fill out the Conversion Responsibility Label and apply to the inside of the furnace door.
11. Turn "ON" the gas supply and electrical power.
12. For complete detailed sequence of operation, refer to the installation instructions or Service Facts with the furnace.
13. Set the thermostat to call for operation.
14. Check the complete operation of the unit. Check the manifold gas pressure **as specified in the installation instructions**. The final manifold pressure should be between 10.5 and 11.0 inches W.C. The final manifold pressure setting for *DH1B065 and M951P065 should be 9.5" W.C.

*First letter may be "A" or "T"

Installer's Guide

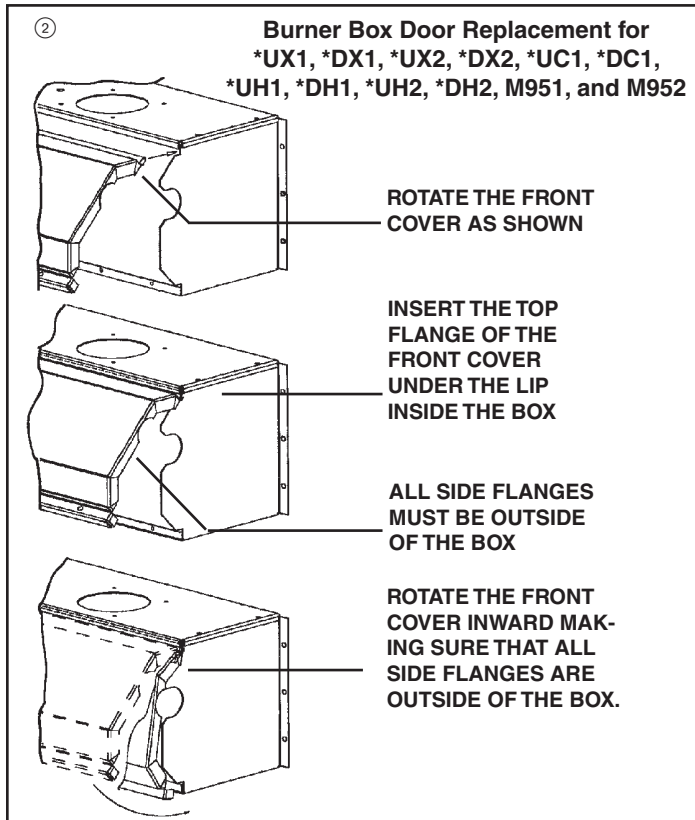
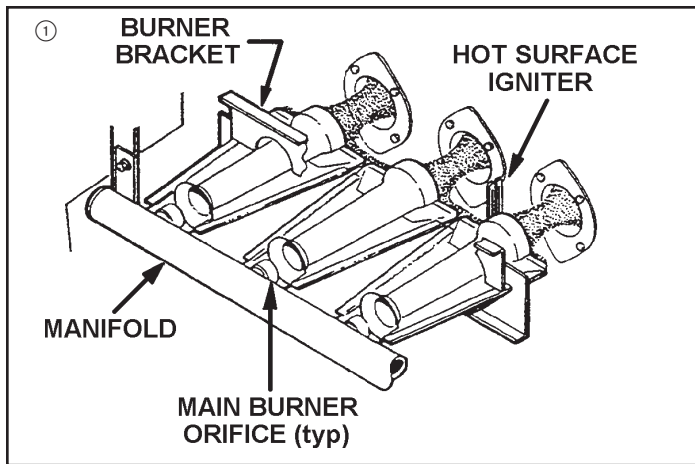

*UH1, *DH1, M951, *UC1, *DC1, *UX1 and *DX1 Models

NOTE: Before the conversion, these models require the removal of the burner box front cover (4 to 6 screws).

After the cover has been removed, follow the conversion instructions (**Steps 1 through 14**), listed for the previous models on Page 1.

At the completion of the conversion, replace the front cover of the burner box as shown in Figure 2.

*UD-R, *DD-R, *UX2, *DX2, *UH2, *DH2 and M952 Models

NOTE: Before the conversion, the *UX2, *DX2, *UH2, *DH2, and M952 models require the removal of the burner box front cover (4 to 6 screws). The *UD-R and *DD-R models do not have a burner box.

NOTE: Since the low fire manifold pressure for propane is higher than the high fire manifold pressure for natural gas, it is necessary to adjust the high fire setting to maximum rate on propane before setting the low fire manifold pressure on propane. If this is not done, the low fire manifold pressure for propane cannot be set above the 3.2" high fire manifold pressure setting for natural gas.

Models using the 36G or 36J two-stage gas valve

After the *UX2, *DX2, *UH2, *DH2, and M952 burner box cover has been removed, follow steps 1 through 6 of the conversion instructions listed on page one.

Remove the natural gas regulator spring located under the high fire regulator screw and discard. This is found under the high adjustment seal screw labeled "HI". See Figure 3. Install the regulator spring included with the kit and apply labels to the gas valve per instructions with the spring. Continue the conversion by following steps 8 through 14 above. The final manifold pressure should be between 10.5 and 11 inches W.C. for high fire and between 5.0 and 6.0 inches W.C. for low fire.

Complete the conversion by replacing the front cover of the burner box on *UX2, *DX2, *UH2, *DH2, and M952 models as shown in Figure 2.

AIRFLOW ADJUSTMENT

Check inlet and outlet air temperatures to make sure they are within the ranges specified on the furnace rating nameplate. If the airflow needs to be increased or decreased, see the wiring diagram for information on changing the speed of the blower motor.

FIGURE 3
TWO STAGE GAS VALVE ONLY

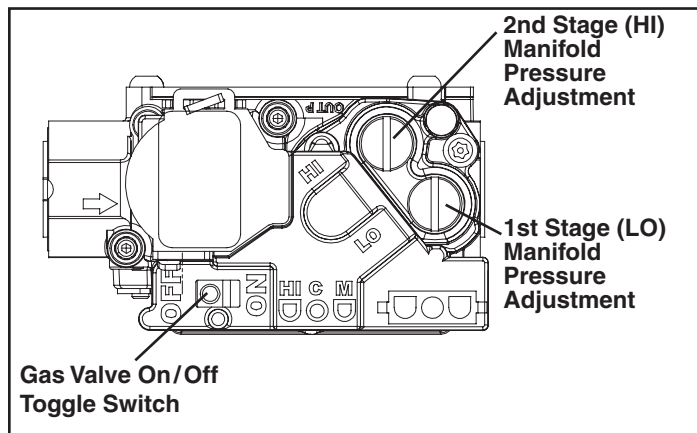

About Trane and American Standard Heating and Air Conditioning

Trane and American Standard create comfortable, energy efficient indoor environments for residential applications. For more information, please visit www.trane.com or www.americanstandardair.com

The manufacturer has a policy of continuous data improvement and it reserves the right to change design and specifications without notice. We are committed to using environmentally conscious print practices.