



18 - CD19D8 - 20

Installer's Guide

Upflow / Horizontal & Downflow / Horizontal, Gas-Fired, Direct Vent, 2-Stage Condensing Furnaces with Variable Speed Inducer

- *UX2B060A9362A *UX2B080A9422A *UX2C100A9482A
- *UX2D120A9602A *DX2B060A9362A *DX2B080A9422A
- *DX2C100A9482A *DX2D120A9602A

*__First letter may be "A" or "T"

ALL phases of this installation must comply with NATIONAL, STATE AND LOCAL CODES

IMPORTANT — This Document is **customer property** and is to remain with this unit. Please return to service information pack upon completion of work.



***UX2**

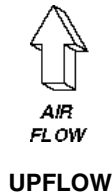
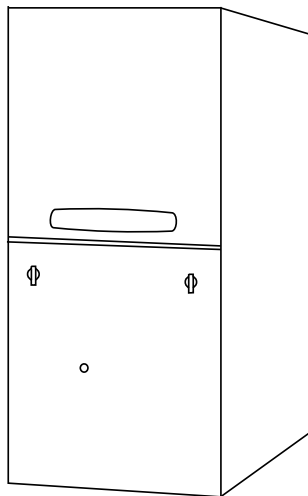

***DX2**

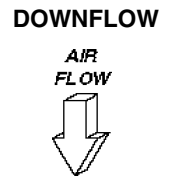
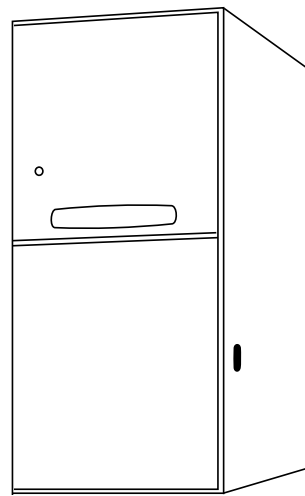

UPFLOW / HORIZONTAL LEFT

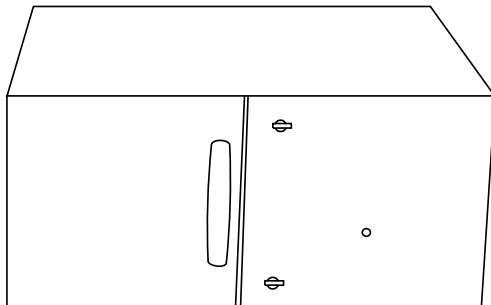

DOWNFLOW / HORIZONTAL RIGHT

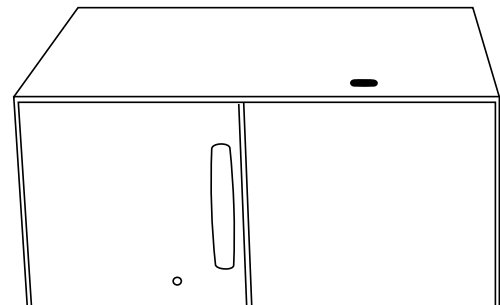

Installer's Guide

SAFETY SECTION

The following safety practices and precautions must be followed during the installation, servicing, and operation of this furnace.

1. Use only with the type of gas approved for this furnace. Refer to the furnace rating plate.
2. Install this furnace only in a location and position as specified in "Location and Clearances" (page 3), of these instructions.
3. Provide adequate combustion and ventilation air to the furnace space as specified in "Air for Combustion and Ventilation" (pages 7-8), of these instructions.
4. Combustion products must be discharged outdoors. Connect this furnace to an approved vent system only, as specified in the "Venting" section (pages 13-23), of these instructions.
5. Never test for gas leaks with an open flame. Use a commercially available soap solution made specifically for the detection of leaks to check all connections, as specified in "Gas Piping" (page 31), of these instructions.
6. Always install the furnace to operate within the furnace's intended temperature-rise range with a duct system which has an external static pressure within the allowable range, as specified on the unit rating plate. Airflow with temperature rise for cfm versus static is shown in the Service Facts accompanying this furnace.
7. When a furnace is installed so that supply ducts carry air circulated by the furnace to areas outside the space containing the furnace, the return air shall also be handled by a duct(s) sealed to the furnace casing and terminating outside the space containing the furnace.
8. A gas-fired furnace for installation in a residential garage must be installed as specified in "Location and Clearances" section (page 3), of these instructions.
9. The furnace may be used for temporary heating of buildings or structures under construction only when the following conditions have been met:
 - a. The furnace venting system must be complete and installed per manufacturer's instructions.
 - b. The furnace is controlled only by a room thermostat (no field jumpers).
 - c. The furnace return air duct must be complete and sealed to the furnace and clean air filters are in place.
 - d. The furnace input rate and temperature rise must be verified to be within nameplate marking.
 - e. 100% of the furnace combustion air requirement must come from outside the structure.
 - f. The furnace return air temperature range is between 55 and 80 degrees Fahrenheit.
 - g. Clean the furnace, duct work, and components upon substantial completion of the construction process, and verify furnace operating conditions including ignition, input rate, temperature rise and venting, according to the manufacturer's instructions.
10. This product must be gas piped by a Licensed Plumber or Gas Fitter in the Commonwealth of Massachusetts.

⚠ CAUTION

To prevent shortening its service life, the furnace should not be used as a "Construction Heater" during the finishing phases of construction until the requirements listed in item 9, a-g of the safety section of this publication have been met. Condensate in the presence of chlorides and fluorides from paint, varnish, stains, adhesives, cleaning compounds, and cement create a corrosive condition which may cause rapid deterioration of the heat exchanger.

⚠ WARNING

CARBON MONOXIDE POISONING HAZARD

Failure to follow the steps outlined below for each appliance connected to the venting system being placed into operation could result in carbon monoxide poisoning or death.

The following steps shall be followed for each appliance connected to the venting system being placed into operation, while all other appliances connected to the venting system are not in operation:

1. Seal any unused openings in the venting system.
2. Inspect the venting system for proper size and horizontal pitch, as required in the National Fuel Gas Code, ANSI Z223.1/NFPA 54 or the CAN/CGA B149 Installation Codes and these instructions. Determine that there is no blockage or restriction, leakage, corrosion and other deficiencies which could cause an unsafe condition.
3. As far as practical, close all building doors and windows and all doors between the space in which the appliance(s) connected to the venting system are located and other deficiencies which could cause an unsafe condition.
4. Close fireplace dampers.
5. Turn on clothes dryers and any appliance not connected to the venting system. Turn on any exhaust fans, such as range hoods and bathroom exhausts, so they are operating at maximum speed. Do not operate a summer exhaust fan.
6. Follow the lighting instructions. Place the appliance being inspected into operation. Adjust the thermostat so appliance is operating continuously.
7. If improper venting is observed during any of the above tests, the venting system must be corrected in accordance with the National Fuel Gas Code, ANSI Z221.1/NFPA 54 and/or CAN/CGA B149 Installation Codes.
8. After it has been determined that each appliance connected to the venting system properly vents where tested as outlined above, return doors, windows, exhaust fans, fireplace dampers and any other gas-fired burning appliance to their previous conditions of use.

Safety signal words are used to designate a degree or level of seriousness associated with a particular hazard. The signal words for safety markings are **WARNING** and **CAUTION**.

- a. **WARNING** indicates a potentially hazardous situation which, if not avoided, could result in death or serious injury.
- b. **CAUTION** indicates a potentially hazardous situation which, if not avoided, may result in minor or moderate injury. It is also used to alert against unsafe practices and hazards involving only property damage.

⚠ WARNING

FIRE OR EXPLOSION HAZARD

Failure to follow the safety warnings exactly could result in serious injury, death or property damage.

Improper servicing could result in dangerous operation, serious injury, death, or property damage.

GENERAL

The manufacturer assumes no responsibility for equipment installed in violation of any code or regulation.

It is recommended that Manual J of the Air Conditioning Contractors Association (ACCA) or A.R.I. 230 be followed in estimating heating requirements. When estimating heating requirements for installation at Altitudes above 2000 ft., remember the gas input must be reduced (See GAS INPUT ADJUSTMENT).

Material in this shipment has been inspected at the factory and released to the transportation agency without known damage. Inspect exterior of carton for evidence of rough handling in shipment. Unpack carefully after moving equipment to approximate location. If damage to contents is found, report the damage immediately to the delivering agency.

Codes and local utility requirements governing the installation of gas fired equipment, wiring, plumbing, and flue connections must be adhered to. In the absence of local codes, the installation must conform with latest edition of the National Fuel Gas Code ANSI Z223.1 • National Installation Code, CAN/CGA B149.1. The latest code may be obtained from the American Gas Association Laboratories, 400 N. Capitol St. NW, Washington D.C. 20001. 1-800-699-9277 or www.aga.org

These furnaces have been classified as CATEGORY IV furnaces in accordance with latest edition of ANSI Z21.47 standards • CAN/CGA 2.3. Category IV furnaces operate with positive vent static pressure and with a flue loss less than 17 percent. These conditions require special venting systems, which must be gas tight and water tight. These Category IV Direct Vent furnaces are approved for installation in Manufactured/Mobile housing when used with BAYMFGH001A.

LOCATION AND CLEARANCES

The location of the furnace is normally selected by the architect, the builder, or the installer. However, before the furnace is moved into place, be sure to consider the following requirements:

1. Is the location selected as near the chimney or vent and as centralized for heat distribution as practical?
2. Do all clearances between the furnace and enclosure equal or exceed the minimums stated in Clearance Table on the Outline Drawings.
3. Is there sufficient space for servicing the furnace and other equipment? A minimum of 24 inches front accessibility to the furnace must be provided. Any access door or panel must permit removal of the largest component.
4. Are there at least 3 inches of clearance between the furnace combustion air openings in the front panel and any closed panel or door provided?
5. Are the ventilation and combustion air openings large enough and will they remain unobstructed? If outside air is used, are the openings set 12" minimum above the highest snow accumulation level (18" in Canadian applications)? (See the Air for Combustion and Ventilation section.)
6. Allow sufficient height in supply plenum above the furnace to provide for cooling coil installation, if the cooling coil is not installed at the time of this furnace installation.
7. A furnace shall be installed so electrical components are protected from water.

Contents

Installation Instructions	3
General	3
Location and Clearances	3
Outline Drawings	4-5
Upflow Installation	6
Downflow Installations	6
Air For Combustion and Ventilation	7
Duct Connections	8
Return Air Filters	9
General Venting	13
Venting Materials	14
Vent Tables	16-22
Horizontal Venting Through Wall	18
Venting Through the Roof	20
Venting Routed Through a Masonry Chimney	20
Downward Venting	22
Condensate Drain Instructions	24
Field Wiring Diagrams	26-29
Electrical Connections	29
Gas Piping	31
Combustion and Input Check	31
High Altitude Derate	33
Start-up and Adjustment	34
Preliminary Inspections	34
Lighting Instructions	34
Sequence of Operation	34
Control and Safety Switch Adjustments	35
Abnormal Conditions	36
IFC Error Flash Codes	37
Fault Code Recovery	37

8. If the furnace is installed in a **residential garage**, it must be installed so that the burners, and the ignition source are located not less than 18 inches above the floor and the furnace must be located or protected to avoid physical damage from vehicles.

IMPORTANT:

The furnace must be installed level. The only allowable variation would be slightly to the left and/or forward in upflow installations or slightly toward the front in horizontal installations. This is necessary for proper condensate drainage.

⚠ CAUTION

Do not install the furnace in a corrosive or contaminated atmosphere. Failure to follow this caution could result in early equipment failure.

⚠ WARNING

FIRE HAZARD

Do not install the furnace directly on carpeting, tile or other combustible material other than wood flooring. For vertical downflow application, subbase (BAYBASE205) must be used between the furnace and combustible flooring. When the downflow furnace is installed vertically with a cased coil, a subbase is not required.

Installer's Guide

*UX2 UPFLOW / HORIZONTAL OUTLINE DRAWING

(ALL DIMENSIONS ARE IN INCHES)

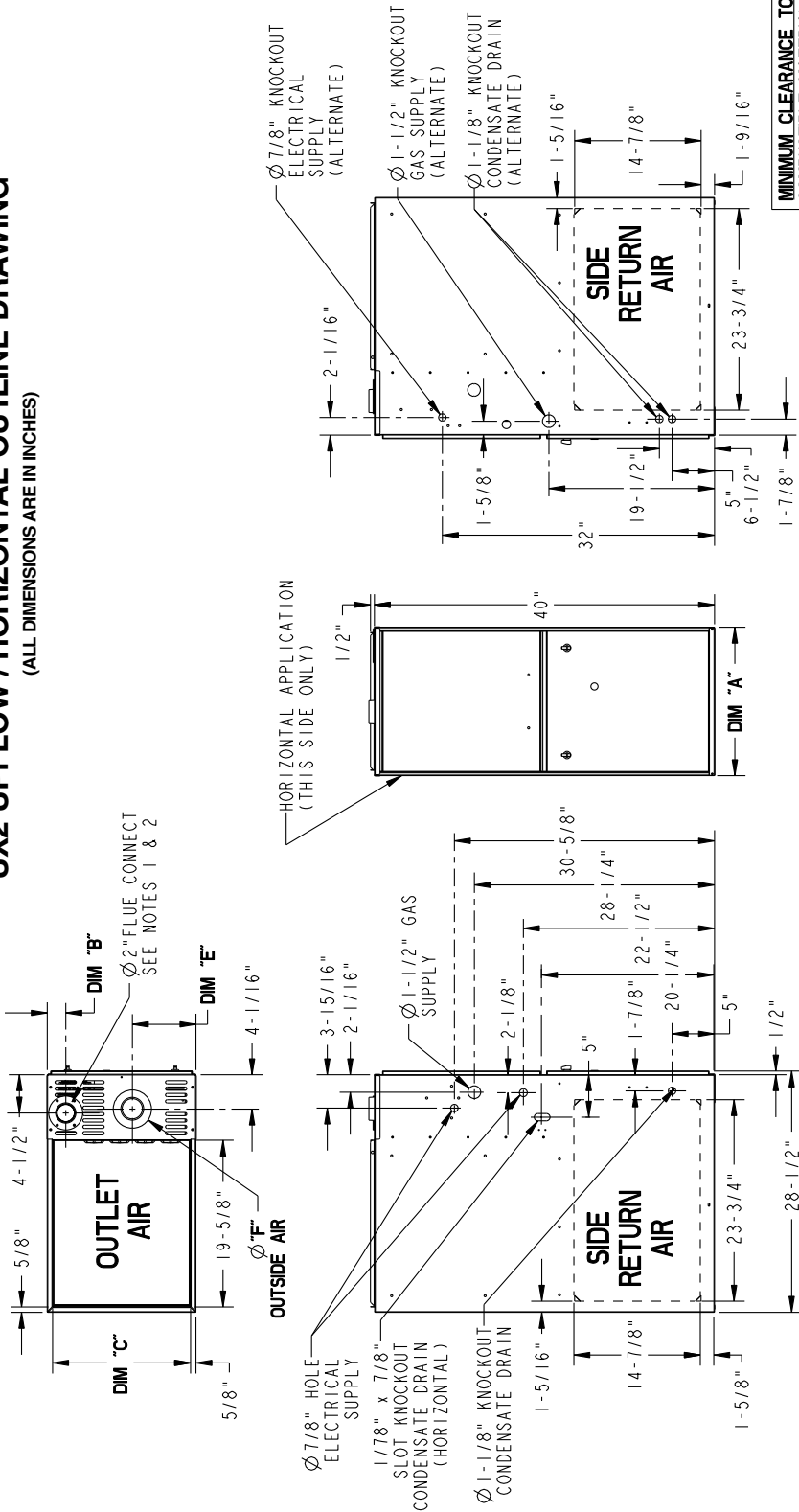

MINIMUM CLEARANCE TO COMBUSTIBLE MATERIALS	
UPFLOW	
SIDES	0 IN.
REAR	0 IN.
FRONT	3 IN.
TOP	1 IN.
FLUE	0 IN.
HORIZONTAL FLUE DISCHARGE ON THE LEFT	
ALCOVE	
SIDES	0 IN.
RIGHT	0 IN.
LEFT	0 IN.
REAR	6 IN.
FRONT	18 IN.
TOP	1 IN.
FLUE	0 IN.
CLOSET	
SIDES	1 IN.
RIGHT	1 IN.
LEFT	3 IN.
REAR	3 IN.
FRONT	1 IN.
TOP	3 IN.
FLUE	0 IN.

Model (See Note 1 & 2)	DIM "A"	DIM "B"	DIM "C"	DIM "D"	DIM "E"	DIM "F"
*UX2B060A9362A	17-1/2"	2-1/4"	16-1/4"	16"	7-1/2"	2"
*UX2B080A9422A	21"	2-1/2"	19-3/4"	19-1/2"	9"	3"
*UX2C100A9482A	24-1/2"	2-15/16"	23-1/4"	23"	10"	3"

- Notes:
 1. *UX2D120A9602A Requires 3" Diameter Vent Pipe.
 *UX2C100A9482A Requires 2-1/2" or 3" Diameter Vent Pipe.
 2. Diameter of Vent Pipe may be limited to 2-1/2" or 3" on some models at different altitudes. Refer to the Vent Length Table for proper application.

* Prefix May Be "A" or "I"

From Dwg. 21C341884 Rev. 1

*DX2 DOWNFLOW / HORIZONTAL OUTLINE DRAWING (ALL DIMENSIONS ARE IN INCHES)

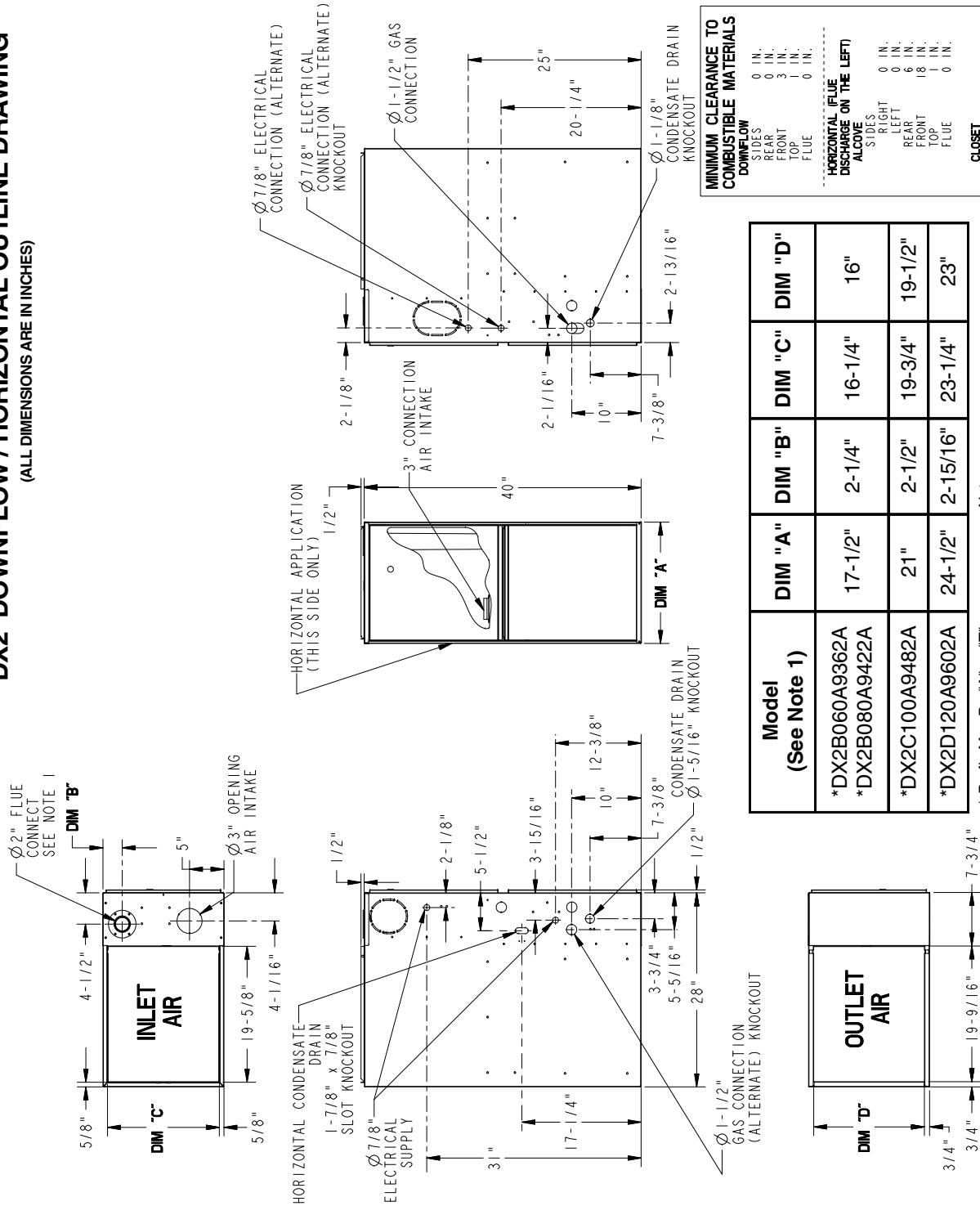

Notes:
 1. Diameter of Vent Pipe may be limited to 2-1/2" or 3" on some models at different altitudes. Refer to the Vent Length Table for proper application.

* Prefix May Be "A" or "T"

Installer's Guide

UPFLOW INSTALLATION

Standoffs and screws (See Figure 1) are included with the cased coils for attachment to the furnace. There are clearance alignment holes near the bottom of the coil wrapper. Drill screws are used to engage the furnace top flanges. The standoff is inserted into the cabinet alignment hole. The drill screws are inserted through the standoffs then screwed into the furnace flange. The coil is always placed downstream of the furnace airflow.

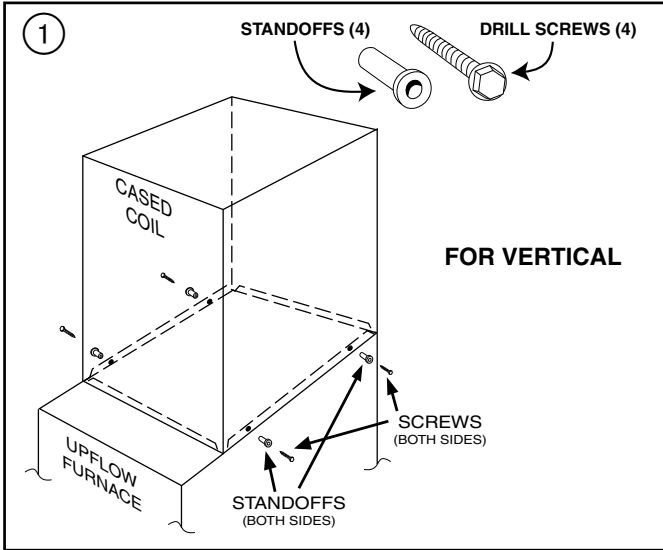

DOWNFLOW INSTALLATIONS

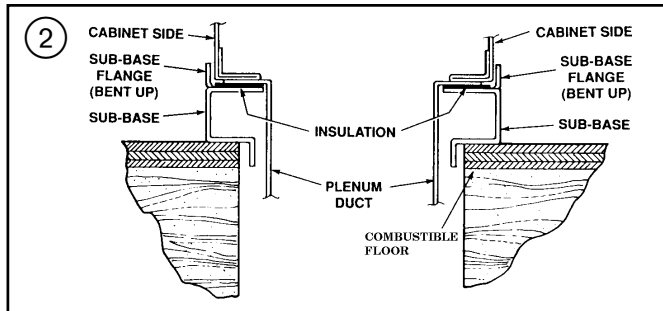

WARNING

FIRE HAZARD

Do not install the furnace directly on carpeting, tile or other combustible material other than wood flooring. For vertical downflow application, subbase (BAYBASE205) must be used between the furnace and combustible flooring. When the downflow furnace is installed vertically with a cased coil, a subbase is not required.

Required floor opening: (DOWNFLOW)
See Figure 3 and Table 1

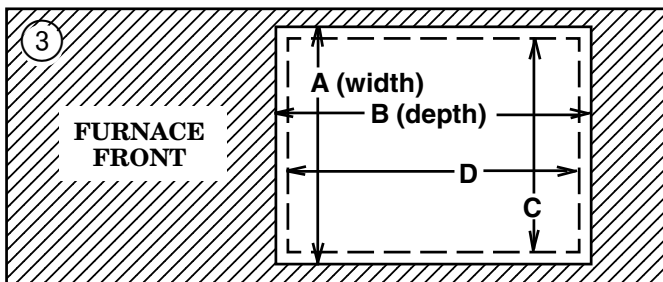

TABLE 1

CABINET WIDTH	RETURN DUCT WIDTH	FLOOR OPENING		PLENUM OPENING	
		"A"	"B"	"C"	"D"
14-1/2"	13-1/4"	13-5/8"	20-1/8"	12-5/8"	19-3/8"
17-1/2"	16-1/4"	16-5/8"	20-1/8"	15-5/8"	19-3/8"
21"	19-3/4"	20-1/8"	20-1/8"	19-1/8"	19-3/8"
24-1/2"	23-1/4"	23-5/8"	20-1/8"	22-5/8"	19-3/8"

HORIZONTAL INSTALLATION

The coil and furnace must be fully supported when used in the horizontal position. It is always recommended that an auxiliary drain pan be installed under a horizontally installed evaporator coil or 90% gas furnace. Connect the auxiliary drain line to a separate drain line (no trap is needed in this line).

Three brackets (with screws) are included with downflow furnaces for installation to stabilize and secure the furnace and TXC cased coil in the **horizontal position**. See Figure 4.

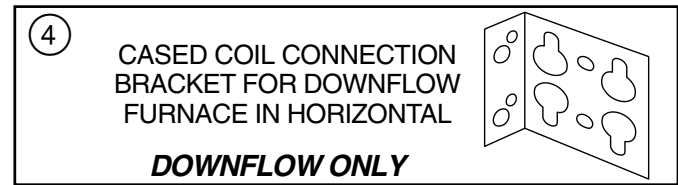

IMPORTANT:

The 2/4TXC cased coil must be placed downstream of the furnace. In horizontal installations, the apex of the coil may point either toward or away from the furnace. See the 2/4TXC coil Installer's Guide for more details.

The cased coil is secured to the furnace and both the furnace and the cased coil must be properly supported. The brackets mount using the rear screws on the coil case and use the screws provided to secure the bracket to the furnace. The remaining bracket is placed as close to center as possible (horizontally) between the coil case front and the furnace bottom channel (for downflow/horizontal furnace). Use four of the screws provided to secure the bracket. The upflow furnace, converted to horizontal, aligns and attaches the TXC coil as in Figure 1. However, the coil requires additional support.

The furnace may be installed in an attic or crawl space in the horizontal position by placing the furnace on the left side (as viewed from the front in the vertical position). The horizontal furnace installation in an attic should be on a service platform large enough to allow for proper clearances on all sides and service access to the front of the furnace (See Figure 5 & Clearance Tables, pages 4-5). Line contact is only permissible between lines formed by intersections of the top and two sides of the furnace casing and building joists, studs, or framing.

The furnace may be placed horizontally in a crawl space on a pad or other noncombustible material which will raise the unit for sufficient protection from moisture.

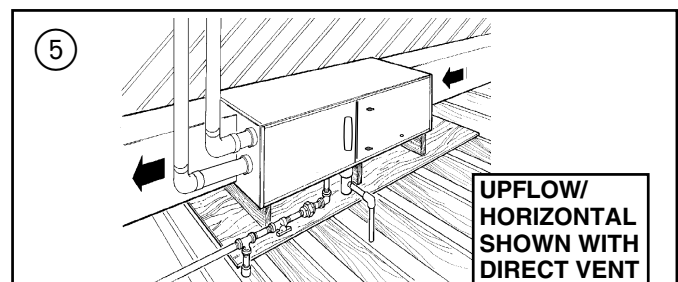

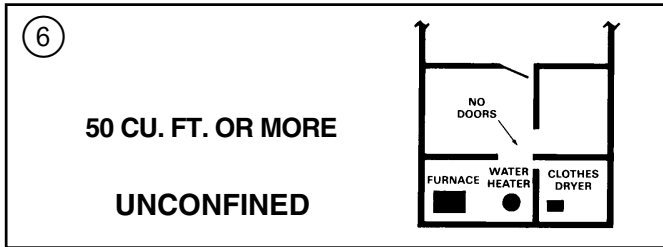

The furnace must be supported at both ends and the middle when installed horizontally. The furnace must also be elevated approximately 4-6 inches to allow clearance for the condensate drain to exit the cabinet in the horizontal position.

The horizontal furnace may also be suspended from the joists using 3/8" all-thread rods with pieces of angle iron underneath the furnace to form a hanging rack at both ends and the midpoint. The rods need to be of sufficient length to allow for proper clearances from combustible materials. The angle iron needs to be at least 32" in length to allow for access to service panels.

AIR FOR COMBUSTION AND VENTILATION

If these furnaces are installed in a nondirect vent capacity then the adequate flow of combustion and ventilating air must not be obstructed from reaching the furnace. Air openings provided for combustion air must be kept free of obstructions which restrict the flow of air. Airflow restrictions affect the efficiency and safe operation of the furnace. Keep this in mind should you choose to remodel or change the area which contains your furnace. Furnaces must have a free flow of air for proper performance.

Provisions for combustion and ventilation air shall be made in accordance with latest edition of Section 5.3, Air for Combustion and Ventilation, of the National Fuel Gas Code, ANSI Z223.1 — CAN/CGA B149.1 or applicable provisions of the local building codes. Special conditions created by mechanical exhausting of air and fireplaces must be considered to avoid unsatisfactory furnace operation.

OUTSIDE AIR IS RECOMMENDED

The use of indoor air for most applications is acceptable, unless **there is the presence of corrosive chemicals or contamination.** Certain types of installation will **require** the use of outside air for combustion.

The following types of installations will **require** use of OUTDOOR AIR for combustion, due to chemical exposures:

- * Commercial buildings
- * Buildings with indoor pools
- * Furnaces installed in "confined" laundry rooms
- * Furnaces installed in "confined" hobby or craft rooms
- * Furnaces installed near chemical storage areas.

Exposure to the following substances in the combustion air supply will also require OUTDOOR AIR for combustion:

- * Permanent wave solutions
- * Chlorinated waxes and cleaners
- * Chlorine based swimming pool chemicals
- * Water softening chemicals
- * Deicing salts or chemicals
- * Carbon Tetrachloride
- * Halogen type refrigerants
- * Cleaning solvents (such as perchloroethylene)
- * Printing inks, paint removers, varnish, etc.
- * Hydrochloric acid
- * Cements and glues
- * Antistatic fabric softeners for clothes dryers
- * Masonry acid washing materials

Furnace locations may be in a "confined space" or an "unconfined space".

Unconfined space is defined in Figure 6. These spaces may have adequate air by infiltration to provide air for combustion and ventilation. Buildings with tight construction (for example, weather stripping, heavily insulated, caulked, vapor barrier, etc.), may need additional air to be provided as described for *confined space*.

Confined spaces are installations with less than 50 cu. ft. of space per 1000 BTU/hr input from all equipment installed. Air for combustion and ventilation requirements can be supplied from inside the building as in Figure 8 or from the outdoors, as in Figure 9.

FURNACE MAXIMUM BTUH INPUT RATING	WITH 8 FT. CEILING MINIMUM AREA IN SQUARE FEET OF UNCONFINED SPACE
60,000	375
80,000	500
100,000	625
120,000	875

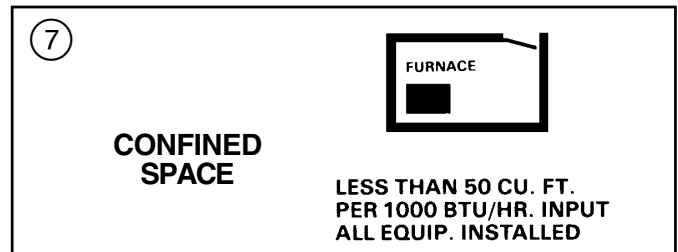

1. All air from inside the building as in Figure 8: The confined space shall be provided with two permanent openings communicating directly with an additional room(s) of sufficient volume so that the combined volume of all spaces meets the criteria for an unconfined space. The total input of all gas utilization equipment installed in the combined space shall be considered in making this determination. Refer to Table 2 for minimum open areas requirements.
2. All air from outdoors as in Figure 9: The confined space shall be provided with two permanent openings, one commencing within 12 inches of the top and one commencing within 12 inches of the bottom of the enclosure. The openings shall communicate directly, or by ducts, with the outdoors or spaces (crawl or attic) that freely communicate with the outdoors. Refer to Table 3, for minimum open areas requirements.

TABLE 3
MINIMUM FREE AREA IN SQUARE INCHES
EACH OPENING (FURNACE ONLY)

Furnace Maximum BTUH/INPUT Rating	Air From Inside	Air From Outside	
		Vertical Duct	Horizontal Duct
60,000	100	15	30
80,000	100	20	40
100,000	100	25	50
120,000	120	30	60

Installer's Guide

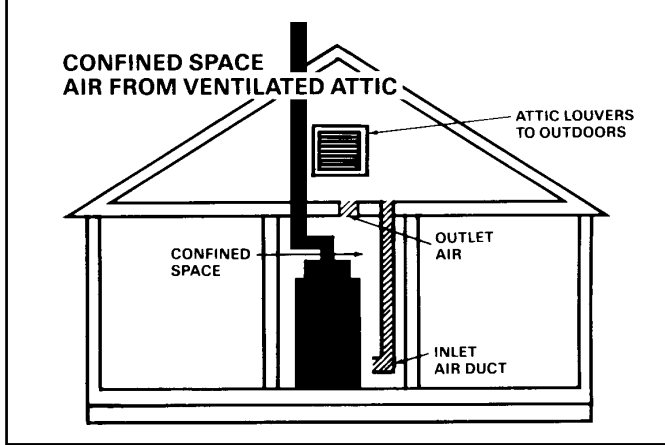
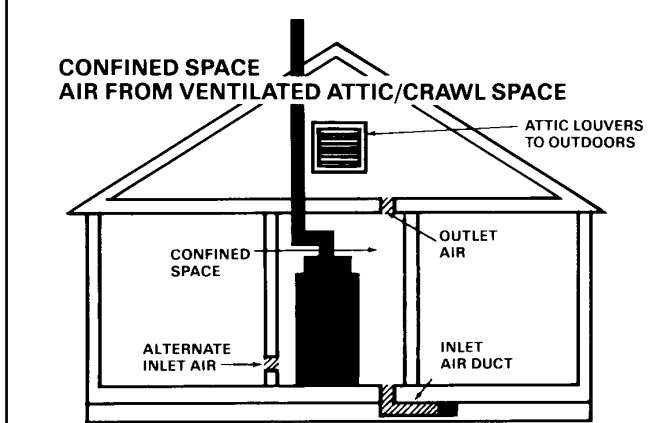
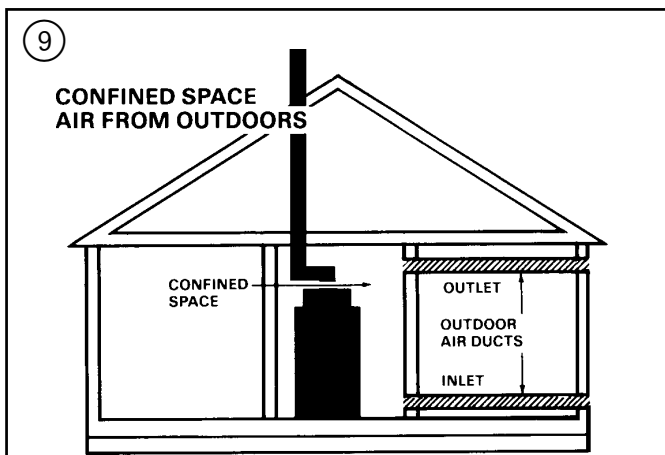
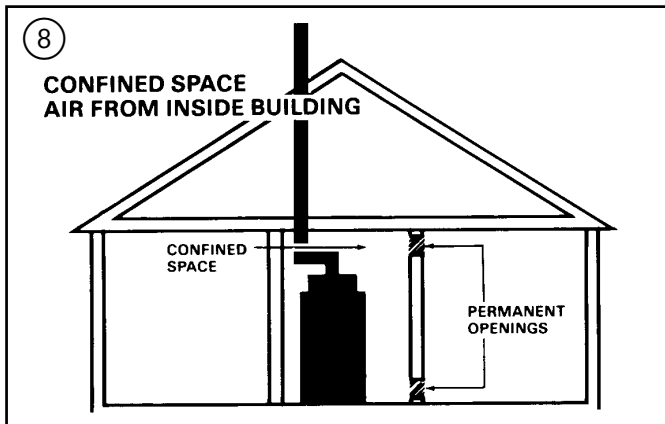

DUCT CONNECTIONS

Air duct systems should be installed in accordance with standards for air conditioning systems, National Fire Protection Association Pamphlet No. 90. They should be sized in accordance with ACCA Manual D or whichever is applicable.

Central furnaces, when used in connection with cooling units, shall be installed in parallel or on the upstream side of the cooling coil to avoid condensation in the heat exchanger. With a parallel flow arrangement, the dampers or other means used to control flow of air shall be adequate to prevent chilled air from entering the furnace, and if manually operated, must be equipped with means to prevent operation of either unit unless the damper is in full heat or cool position.

On any job, flexible connections of nonflammable material may be used for return air and discharge connections to prevent transmission of vibration. Though these units have been specifically designed for quiet, vibration free operation, air ducts can act as sounding boards and could, if poorly installed, amplify the slightest vibration to the annoyance level.

When the furnace is located in a utility room adjacent to the living area, the system should be carefully designed with returns to minimize noise transmission through the return air grille. Although these furnaces are designed with large blowers operating at moderate speeds, any blower moving a high volume of air will produce audible noise which could be objectionable when the unit is located very close to a living area. It is often advisable to route the return air ducts under the floor or through the attic. Such design permits the installation of air return remote from the living area (i.e. central hall).

When the furnace is installed so that the supply ducts carry air circulated by the furnace to areas outside the space containing the furnace, the return air shall also be handled by a duct(s) sealed to the furnace and terminating outside the space containing the furnace.

RETURN AIR DUCT CONNECTION

NOTE:

On upflow 5 or 6 ton airflow models where the airflow requirement exceeds 1800 CFM - Models will require return air openings and filters on: (1) both sides; or (2) one side and the bottom; or (3) just the bottom.

All return air duct systems should provide for installation of return air filters.

1. Determine the appropriate position to set the furnace in order to connect to the existing supply and return ductwork.
2. For side return installations on upflow models, remove the insulation around the opening in the blower compartment.
3. The side panels of the upflow furnace include locating notches that are used as guides for cutting an opening for return air, refer to Figure 10 and the outline drawing on page 4 for duct connection dimensions for various furnaces.

- If a 3/4" flange is to be used for attaching the air inlet duct, add to cut where indicated by dashed lines in Figure 11. Cut corners diagonally and bend outward to form flange.
- If flanges are not required, and a filter frame is installed, cut along knockout guidelines.
- Upflow Furnaces:** Use the optional filter rack on either side or on the bottom if the filter is to be used within the furnace cabinet.

When the upflow furnace is installed in the horizontal right or left application and a return duct is attached to the top side as shown in Figure 10, install the filter in a remote location.

⚠ WARNING

FIRE OR EXPLOSION HAZARD

Do not install the filter in the return duct directly above the furnace in horizontal applications. Install the filter remotely. Failure to follow the safety warnings exactly could result in serious injury, death or property damage.

⚠ WARNING

SAFETY HAZARD

To prevent injury or death due to contact with moving parts, turn the power to the furnace off before servicing filters

Failure to follow the safety warnings exactly could result in serious injury, death or property damage.

Do not install the filter in the return duct directly above the furnace in horizontal applications.

When the upflow furnace is installed in the horizontal right or left application and a close coupled (less than 36") return duct is attached to the bottom side of the furnace as shown in Figure 10, securely attach a 1/2" mesh metal hardware cloth protective screen to the inside bottom of the filter grill to prevent personal injury from contacting moving parts when reaching into the return opening to replace the filter.

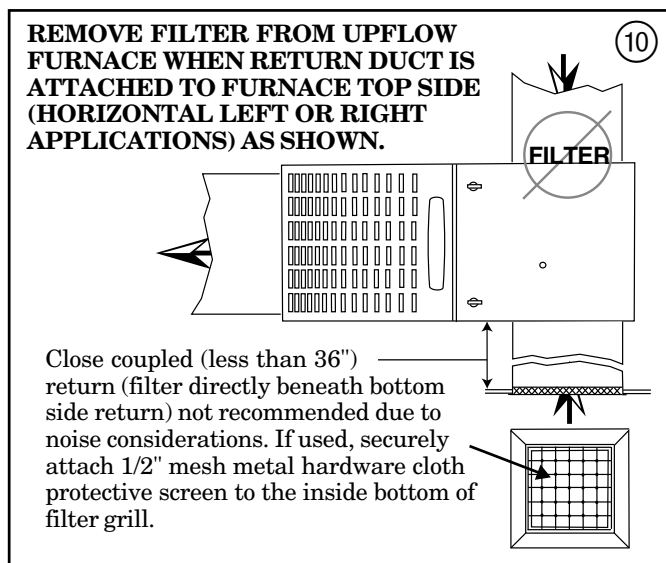

Close coupled (less than 36") return (filter directly beneath bottom side return) is not recommended due to noise considerations.

Downflow Furnaces: Brackets are factory supplied to mount filters in the return air duct work.

- Connect the duct work to the furnace. See Outline Drawing (pages 4&5) for supply and return duct size and location. Flexible duct connectors are recommended to connect both supply and return air ducts to the furnace. If only the front of the furnace is accessible, it is recommended that both supply and return air plenums are removable.
- When replacing a furnace, old duct work should be cleaned out. Thin cloths should be placed over the registers and the furnace fan should be run for 10 minutes. Don't forget to remove the cloths before you start the furnace.

Return Air Filters (Filter and filter rack are not supplied with unit)

TYPICAL UPFLOW RETURN AIR FILTER INSTALLATIONS

These furnaces require high velocity type air filters. The optional filters may be located within the furnace blower compartment for UPFLOW furnaces in either a BOTTOM or SIDE (left side or right side) return air inlet. Some optional filters may need to be trimmed for side or bottom filter use.

NOTE:

On upflow 5 or 6 ton airflow models where the airflow requirement exceeds 1800 CFM - Models will require return air openings and filters on: (1) both sides; or (2) one side and the bottom; or (3) just the bottom.

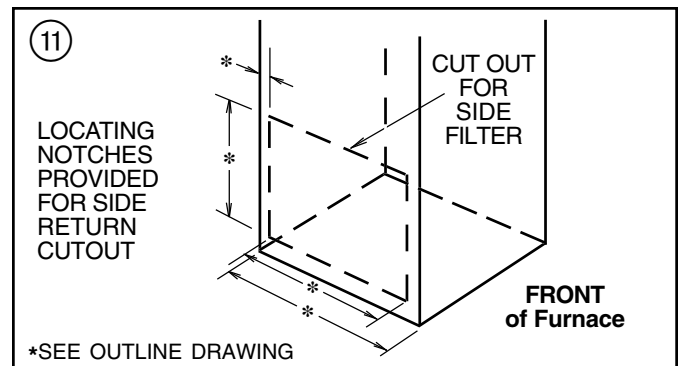

The furnace and the blower filter rack installation can be seen in Figures 12 & 13.

The optional furnace filter in the bottom or side configuration can be removed by simply turning the two latches on the blower door and tilting the door forward.

The filter rails are spring loaded for automatic adjustment to allow standard size, locally obtainable replacement filters. The filter rack itself slides to adjust to the required width needed for bottom or side return.

Installer's Guide

TABLE 4

UPFLOW FURNACE RETURN AIR FILTERS			
CABINET WIDTH	QTY*	CABINET BOTTOM FILTER	CABINET SIDE FILTER
14-1/2"	1	14" X 25" X 1"	17-1/2" X 25" X 1"
17-1/2"	1	17" X 25" X 1"	17-1/2" X 25" X 1"
21"	1	20" X 25" X 1"	17-1/2" X 25" X 1"
24-1/2"	1	24" X 25" X 1"	17-1/2" X 25" X 1"

**NOTE: For upflow 5 ton airflow models where the airflow requirement exceeds 1800 CFM - Models will require return air openings and filters on: (1) both sides, or (2) one side and the bottom, or (3) just on the bottom

NOTE: The narrow 14.5" width furnace cabinet prevents use of the filter rack for right side return. Pre-drill clearance holes and then attach filter clips with the screws provided. The filter clip with the leaf spring mounts in the rear of the cabinet

OPTIONAL FILTER RACK INSTALLATION FOR BOTTOM RETURN

With the filter removed, the filter rack is compressed and then inserted into the bottom of the furnace. The retaining screw/pin on each side inserts into engagement holes at the bottom of the furnace cabinet side. See Figures 13, 14 & 16.

NOTE: Remove the bottom front channel to install the filter rack in the 14-1/2" width cabinet furnaces.

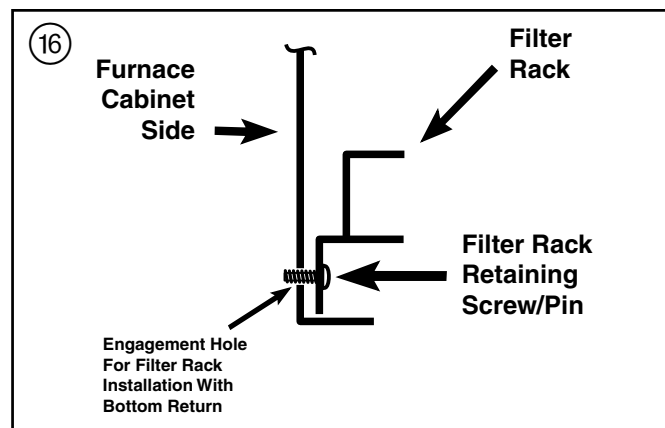
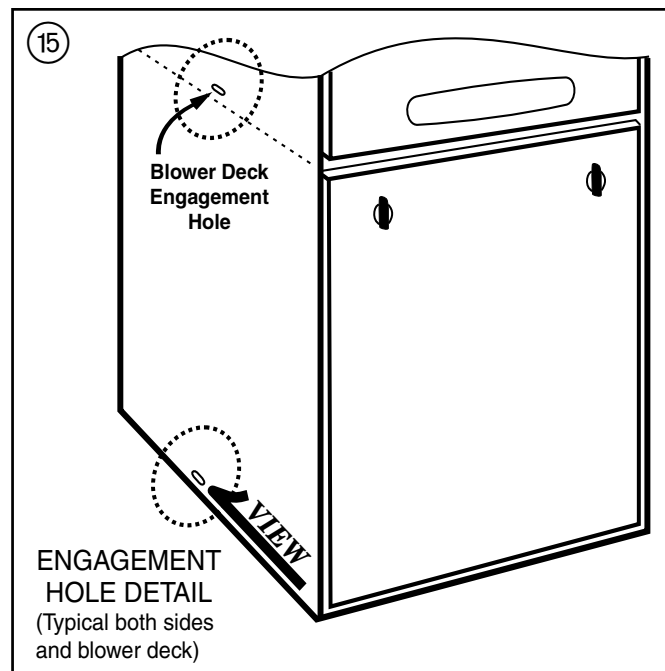
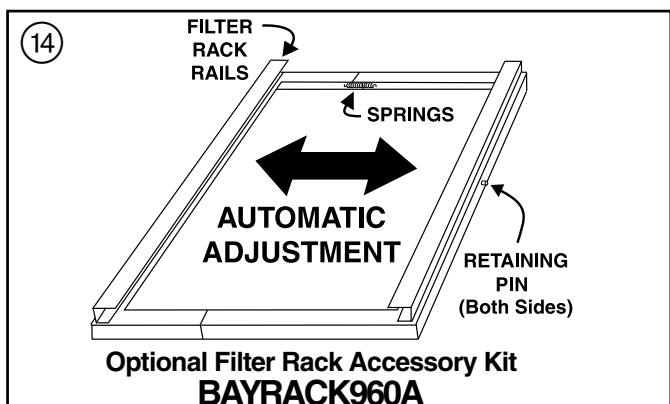
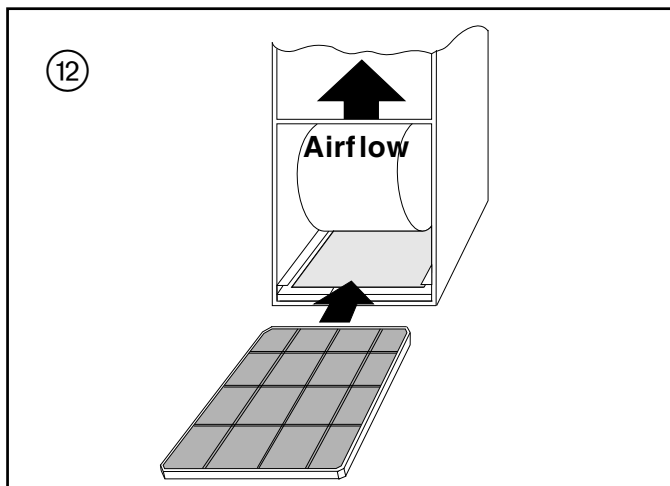

TABLE 5

Cabinet Width	Left Side	Bottom	Right Side
14.5	X ¹	X ²	Use Alternate Filter Clips Only
17.5	X	X	X
21	X	X	X
24.5	X	X	X

1. UC1B060C has 10x7 blower which requires use of alternate filter clips for left side filter. "K1" and later use the filter rack.
 2. Remove bottom front channel to install or reposition filter rack.
 X - All Models

OPTIONAL FILTER RACK INSTALLATION FOR SIDE RETURN AIR ON UPFLOW FURNACES (Left or Right)

If side air return is desired, the following instructions should be used:

- Open or remove the blower door.
- Leave the bottom panel in place. (Some models require field supplied bottom panels.)
- After the side cutout is made following the directions in the "Return Air Duct Connections" section on pages 8 and 9; compress the filter rack and reinstall in the side of the furnace. Confirm that the upper retaining pin/screw locks into the engagement hole in the blower deck and the lower pin/screw rests against the side of the bottom panel. See Figures 14, 15, & 17-20.
- Install the furnace filter on the side. See Figures 14, 15, & 17-20.

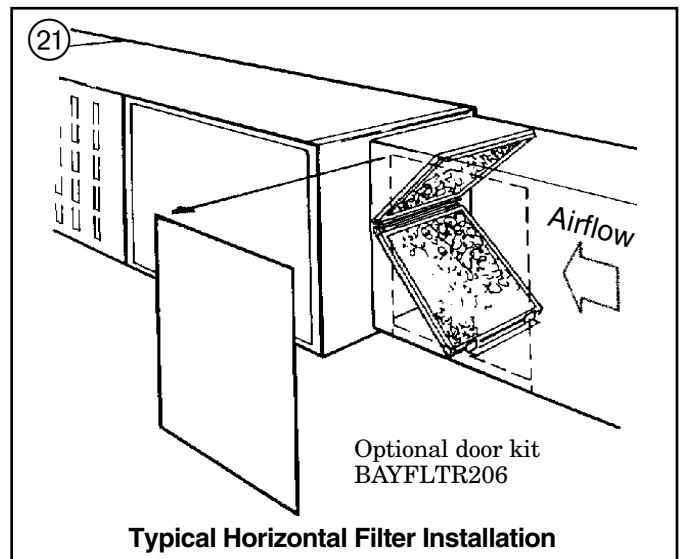
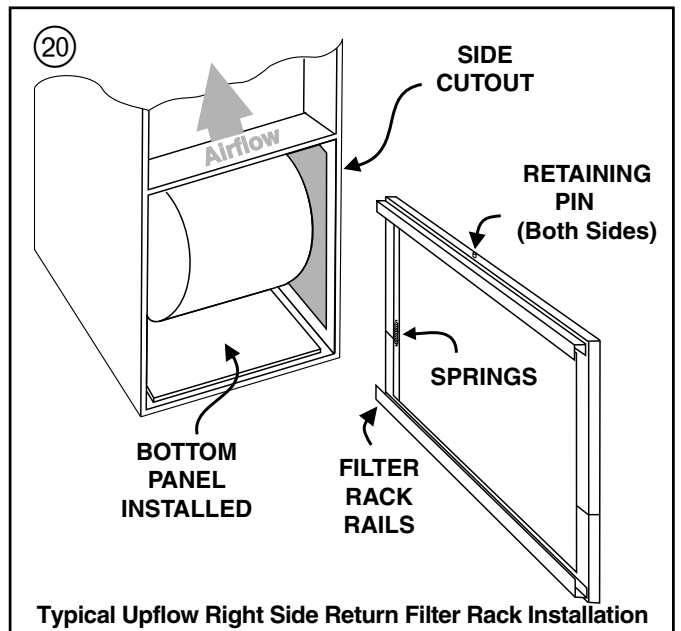
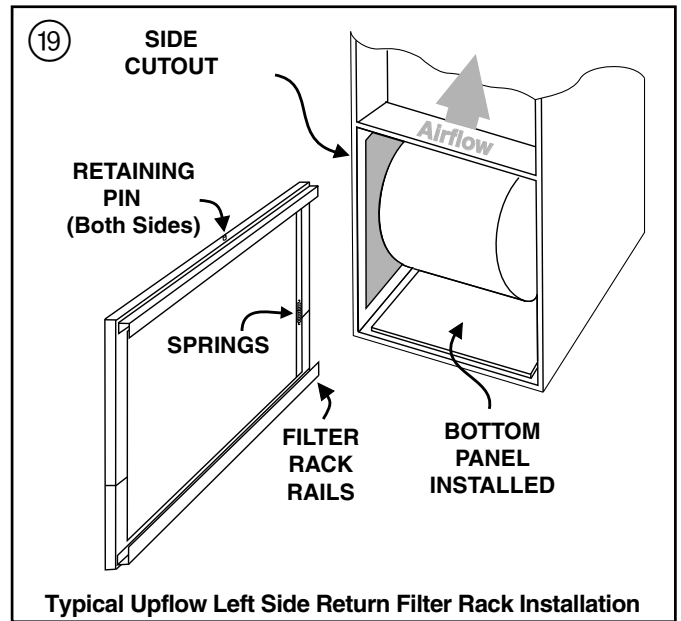
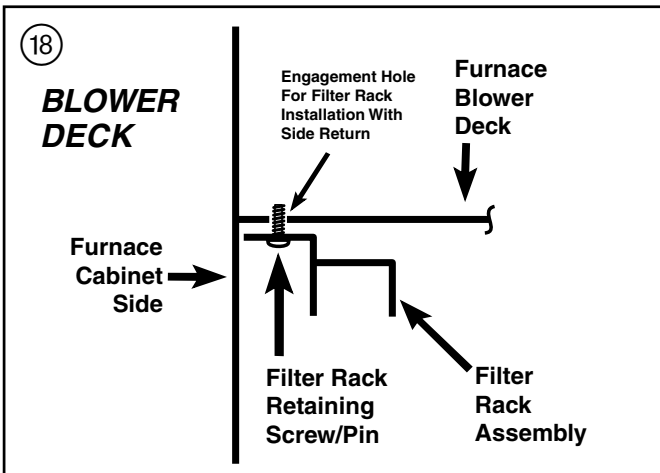
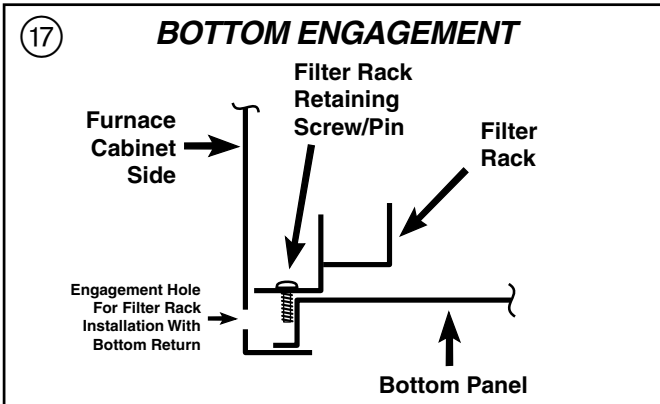

Installer's Guide

RETURN AIR FILTERS FOR UPFLOW FURNACE IN HORIZONTAL CONFIGURATION

When the Upflow Furnace is installed in a horizontal configuration, the filter must never be installed inside or outside the cabinet directly above the blower assembly. See Figure 11 (page 9). Remote filter grilles may be used for homeowner convenience or the filters may be installed in the duct work upstream of the furnace. See Figures 11 (page 9) and 21 (page 11).

ALTERNATE UPFLOW

FILTER CLIP / BRACKET INSTALLATION - KIT09224

1. Determine the location to be used. The furnace cabinet has dimples for location of the alternate furnace clips (*Side return only*). Pre-drill clearance holes with a 3/16" drill. Bottom return holes are pre-drilled.
2. Install the clips in front and rear of the desired location using the screws provided. The filter clip with the leaf spring mounts in the rear of the cabinet. See Figure 22.

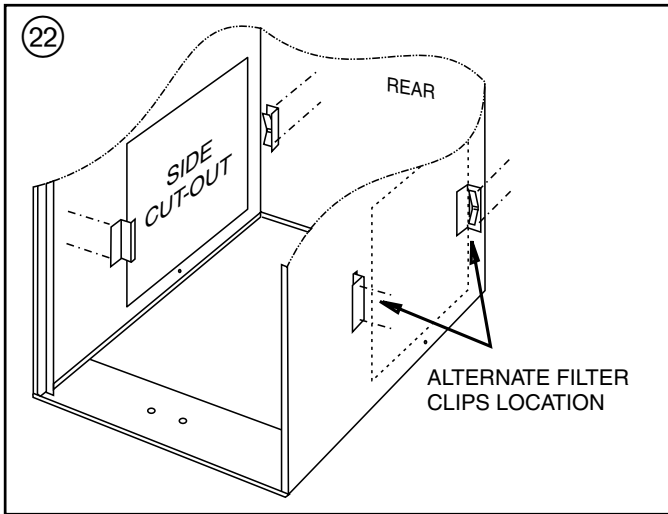

Optional horizontal filter conversion kits are BAYFLTR203 for 17 1/2" width cabinets, BAYFLTR204 for 21" width cabinets, and BAYFLTR205 for 24" width cabinets. These include filters and brackets necessary for horizontal filters. In addition, optional door kit BAYFLTR206 is also available. See Figures 21 and 24.

INSTALLING THE OPTIONAL FILTER

The filter may need to be cut to fit the unit depending on the location of the return air filter.

A score line and the words "CUT HERE" are located on the end of the filter. If your application requires cutting the filter, do so as indicted by the score mark.

TABLE 6

UNIT SIZE	RETURN AIR	
	BOTTOM	SIDE
14-1/2"	CUT ON LINE	DO NOT CUT
17-1/2"	DO NOT CUT	DO NOT CUT
21"	DO NOT CUT	CUT ON LINE
24-1/2"	DO NOT CUT	CUT ON LINE

TYPICAL DOWNFLOW FURNACE RETURN AIR FILTER INSTALLATIONS

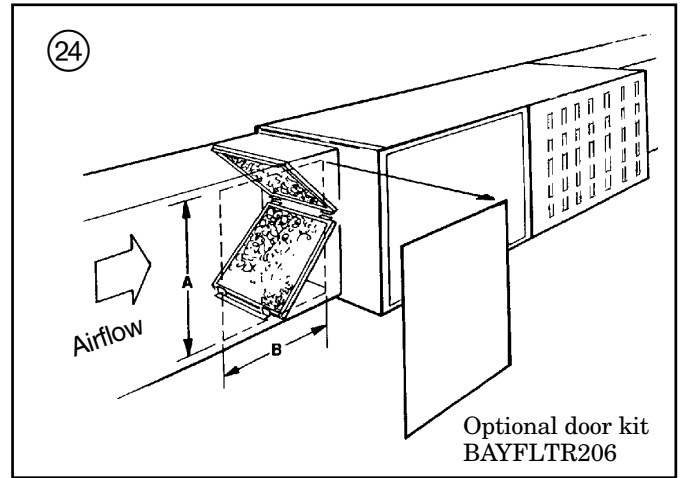
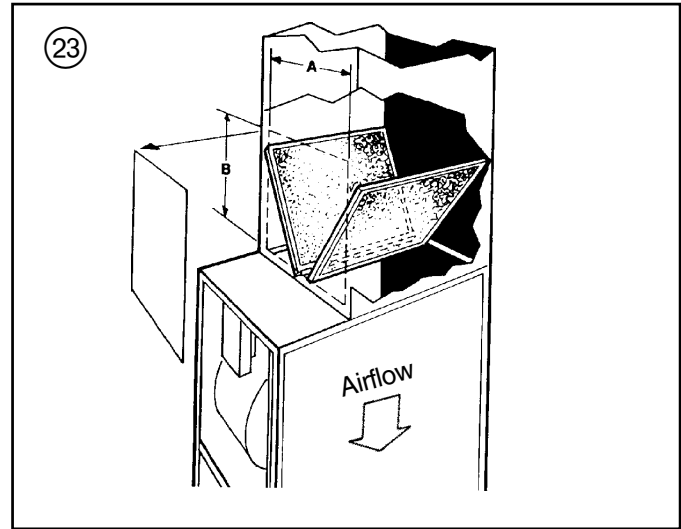

Two high velocity type air filters are required for each downflow furnace. Downflow furnace filters must be located outside the furnace cabinet. Typical installations are shown in Figures 23 and 24. Tables 7 and 8 provide information for installation of the filter retaining brackets shipped with downflow furnaces.

TABLE 7

CABINET WIDTH	FILTER SIZE	FILTER BRACKET LOCATION *
14-1/2"	2 - 14X20X1	12-7/8"
17-1/2"	2 - 16X20X1	14-3/8"
21"	2 - 16X20X1	13-1/8"
24-1/2"	2 - 16X20X1	11-5/8"

* Location dimension is from end of duct to the screw holes for the bracket.

TABLE 8

CABINET WIDTH	RETURN DUCT WIDTH	FILTER ACCESS OPENING - DIMENSION "A"	FILTER ACCESS OPENING - DIMENSION "B"
14-1/2"	13-1/4"	12"	14"
17-1/2"	16-1/4"	15"	14"
21"	19-3/4"	19-1/2"	14"
24-1/2"	23-1/4"	22"	14"

The following warning complies with State of California law, Proposition 65.

WARNING

Hazardous Gases!

Exposure to fuel substances or by-products of incomplete fuel combustion is believed by the state of California to cause cancer, birth defects, or other reproductive harm.

Carbon monoxide, fire or smoke can cause serious bodily injury, death, and/or property damage.

A variety of potential sources of carbon monoxide can be found in a building or dwelling such as gas-fired clothes dryers, gas cooking stoves, water heaters, furnaces and fireplaces. The U.S. Consumer Product Safety Commission recommends that users of gas-burning appliances install carbon monoxide detectors as well as fire and smoke detectors per the manufacturer's installation instructions to help alert dwelling occupants of the presence of fire, smoke or unsafe levels of carbon monoxide. These devices should be listed by Underwriters Laboratories, Inc. *Standards for Single and Multiple Station Carbon Monoxide Alarms, UL 2034* or CSA International Standard, *Residential Carbon Monoxide Alarming Devices, CSA 6.19*

NOTE:

The manufacturer of your furnace does not test any detectors and makes no representations regarding any brand or type of detector.

GENERAL VENTING

THIS FURNACE MUST BE VENTED TO THE OUTDOORS. THESE FURNACES ARE INDUCED DRAFT VENTED AND MUST NOT BE CONNECTED TO ANY VENT SERVING ANOTHER APPLIANCE. PLEASE NOTE THAT THESE FURNACES USE POSITIVE-PRESSURE VENT SYSTEMS.

Proper venting is essential to obtain maximum efficiency from a condensing furnace. Proper installation of the vent system is necessary to assure drainage of the condensate and prevent deterioration of the vent system.

American Gas Association has certified the design of condensing furnaces for a minimum of 0" clearance from combustible materials with a single wall plastic vent pipe.

The recommended system is assembled from 2", 2-1/2", or 3" plastic pipe and fittings (See Table 9, page 15). Where the system is routed to the outdoors through an existing masonry chimney containing flue products from another gas appliance, or where required by local codes, then 3" venting of Type 29-4C stainless steel must be used in place of PVC material.

These furnaces have been classified as CATEGORY IV furnaces in accordance with ANSI Z21.47 "latest edition" standards. Category IV furnaces operate with positive vent pressure and with a vent gas temperature less than 140° F. above the dewpoint. These conditions require special venting systems, which must be gas tight and water tight.

NOTE:

When an existing furnace is removed from a venting system serving other gas appliances, the venting system is likely to be too large to properly vent the remaining attached appliances.

The following steps shall be followed with each appliance remaining connected to the common venting system placed in operation, while the other appliances remaining connected to the common venting system are not in operation.

1. Seal any unused openings in the common venting system.
2. Visually inspect the venting system for proper size and horizontal pitch and determine there is no blockage or restriction, leakage, corrosion or other deficiencies which could cause an unsafe condition.
3. Insofar as is practical, close all building doors and windows and all doors between the space in which the appliances remaining connected to the common venting system are located and other spaces of the building. Turn on clothes dryers and any appliances not connected to the common venting system. Turn on any exhaust fans, such as range hoods and bathroom exhausts, so they will operate at maximum speed. Do not operate a summer exhaust fan, close fireplace dampers.
4. Follow the lighting instructions. Place the appliance being inspected in operation. Adjust thermostat so appliance will operate continuously.
5. After it has been determined that each appliance remaining connected to the common venting system properly vents when tested as outlined above, return door, windows, exhaust fans, fireplace dampers and any other gas-burning appliance to their previous conditions of use.

If improper venting is observed during any of the above tests, the remaining common venting system must be corrected. Correction could require rerouting or resizing the remaining vent system.

IMPORTANT:

*These furnaces may be installed as Direct Vent (sealed combustion) or as Nondirect vent (single pipe). The furnaces are shipped **DIRECT VENT** with sealed combustion.*

*For **DIRECT VENT APPLICATION**: The furnaces must be vented to the exterior of the house and combustion air **MUST** come through the inlet air pipe **FROM OUTSIDE AIR**. The pipes **DO NOT** have to exit the exterior of the house together or on the same side of the house.*

*For **NONDIRECT VENT APPLICATION**: The furnace shall be vented to the exterior of the house, but combustion air may enter from the surrounding area as long as combustion air requirements are met. (See **AIR FOR COMBUSTION AND VENTILATION**)*

FURNACE VENT/INLET PIPE INSTALLATION

There are many different variations of the vent/inlet air pipe combination. The vent/inlet air combination used for installation of these furnaces depends on the needs of the location. However, these guidelines must be followed:

1. The furnace must vent outside the structure.
2. Furnace combustion air requirements must be met for nondirect, single pipe applications (See example on next page).
3. For direct vent application of these furnaces, the vent pipe and air inlet pipe do not have to exit in the same air space or even on the same surface of the structure. *However, the longest individual pipe will decide the value for the longest allowable equivalent vent / inlet air length as shown in the vent length table.*

Installer's Guide

NOTE:

BAYVENT200* accessories can be used for inlet and outlet terminals when the pipes do not exit the structure together. For Canadian applications ONLY, IPEX 196006 may be used for horizontal and vertical terminations. IPEX 081216, IPEX 081218, and IPEX 081219 may only be used for horizontal vent terminations.

The following are **EXAMPLES ONLY**:

EX. 1 —

Example 1 shows that the vent may go vertical while the inlet air may be on any side of the structure. The vent pipe would decide the maximum equivalent length for the pipe depending on the furnace and pipe size.

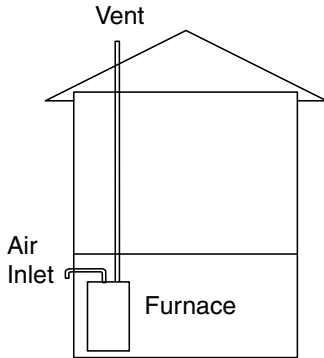

EX. 2 —

Example 2 shows the vent pipe exhausting through the roof and the inlet air coming from the interior of the house (See Note). The inlet air coming from the interior of the house must meet combustion requirements for area, etc., as shown in the section AIR FOR COMBUSTION AND VENTILATION in this Installer's Guide.

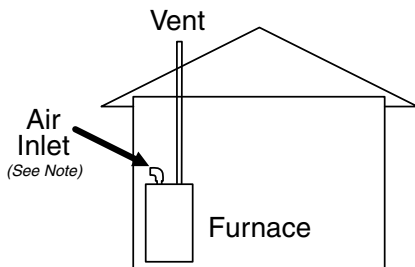

EX. 3 —

Example 3 shows the vent exiting one side of the house while the inlet air is on the opposite side of the structure. Here the vent pipe length must be within the allowable length for the size of furnace and size of the vent pipe. This example demonstrates that the pipes do not have to exit on the same side of the structure.

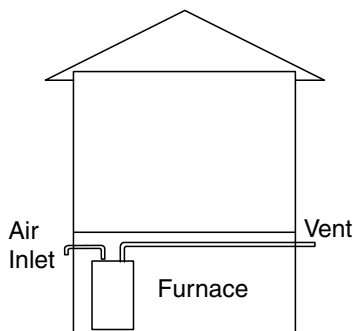

EX. 4 —

The inlet air does not have to come from outside the structure. Example 4 shows the inlet air (See Note), may come from the attic if the requirements for combustion air are met as shown in the section AIR FOR COMBUSTION AND VENTILATION.

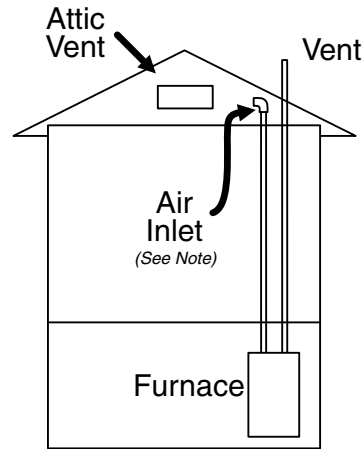

NOTE:

If only the flue gas pipe is to the outside of the structure, a straight section of pipe (long enough to exit the furnace cabinet) must be attached to the inlet air side with an elbow (which is 5 to 10 equiv. ft.) installed on the end to prevent dust and debris from falling directly into the furnace.

VENT FITTING MATERIAL – PLASTIC

Gas and liquid tight single wall vent fittings, designed for resistance to corrosive flue condensate, **MUST** be used throughout.

Listed in Table 9 are 2", 2-1/2", and 3" size fittings that meet these requirements. The materials listed are various grades of PVC and ABS plastic.

PIPE JOINTS: All joints must be fastened and sealed to prevent escape of combustion products into the building.

NOTE:

It is recommended that the first joints from the furnace be connected and sealed with high temperature RTV. This will enable the pipes to be removed later without cutting.

Be sure to properly support these joints.

BONDING OF PVC

Commercially available solvent cement for PVC must be used to join PVC pipe fittings. Follow instructions on container carefully.

Pipe and Fitting – ASTM D1785, D2466, D2661, & D2665

PVC Primer and Solvent Cement – ASTM D2564

Procedure for Cementing Joints – Ref ASTM D2855

1. Cut pipe square, remove ragged edges and burrs. Chamfer end of pipe, then clean fitting socket and pipe joint area of all dirt, grease, moisture or chips.
2. After checking pipe and socket for proper fit, wipe socket and pipe with cleaner-primer. Apply a liberal coat of primer to inside surface of socket and outside of pipe.
DO NOT ALLOW PRIMER TO DRY BEFORE APPLYING CEMENT.
3. Apply a thin coat of cement evenly in the socket. Quickly apply a heavy coat of cement to the pipe end and insert pipe into fitting with a slight twisting movement until it bottoms out.

4. Hold the pipe in the fitting for 30 seconds to prevent tapered socket from pushing the pipe out of the fitting.
5. Wipe all excess cement from the joint with a rag. Allow 15 minutes before handling. Cure time varies according to fit, temperature and humidity.

NOTE:

Follow venting instructions carefully when using PVC cement.

IMPORTANT:

All joints must be water tight. Flue condensate is somewhat acidic, and leaks can cause equipment damage.

TABLE 9

PLASTIC PIPE DESIGNATIONS			
PVC			
ASTM STANDARD	PIPE TYPE	ALLOWABLE TEMPERATURE	MARKING
F891	CELLULAR CORE	*158	ASTM F891
D2665	DWV PIPE	**158	ASTM D2665
D1785	SCH 40, 80, 120	**158	ASTM D1785
D2241	SDR SERIES	**158	ASTM D2241
CPVC			
ASTM STANDARD	PIPE TYPE	ALLOWABLE TEMPERATURE	MARKING
D2846	CPVC 41	**212	ASTM D2846
F441	SCH 40, 80	**212	ASTM F441
F442	SDR SERIES	**212	ASTM F442
ABS			
ASTM STANDARD	PIPE TYPE	ALLOWABLE TEMPERATURE	MARKING
D2661	SCH 40 DWV	***180	ASTM D2661
F628	SCH 40 DWV CELLULAR CORE	***180	ASTM F628

* - Allowable temperatures based on classifications covered in ASTM D4396 [Deflection Temps Under Load (264 PSI)]
 ** - Allowable temperatures based on classifications covered in ASTM D1784 [Deflection Temps Under Load (264 PSI)]
 *** - Allowable temperatures based on classifications covered in ASTM D3965 [Deflection Temps Under Load (264 PSI)]

PVC VENT FITTING MATERIAL These fittings are available from your Gas Furnace Distributors.

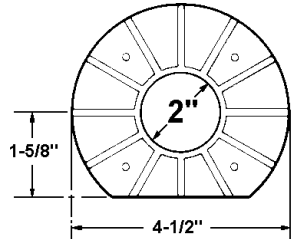

**WALL MOUNT FLANGE
BAY69X148**

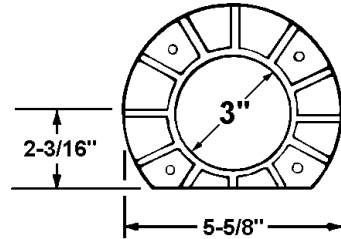

**WALL MOUNT FLANGE
BAY69X147**

Connection of the pipe and collar of the combustion air inlet should just be a friction fit. It is recommended that the inlet air joint be sealed with RTV type sealant to allow the joint to be separated for possible future service. The inlet and vent pipes must be properly supported throughout the entire length.

Connection of the vent pipe to the vent collar should also be accomplished using RTV type sealant. This type sealant provides a connection which remains flexible and can be separated in the future if service needs require the removal of the vent pipe for service or clearance.

NOTE:

Vent termination kit **BAYAIR30AVENTA** or **BAYVENT200B** may be used in addition to the horizontal and vertical termination options shown in the following figures. For Canadian applications ONLY: **IPEX 196006** may be used for horizontal and vertical terminations. **IPEX 081216**, **IPEX 081218**, and **IPEX 081219** may only be used for horizontal vent terminations.

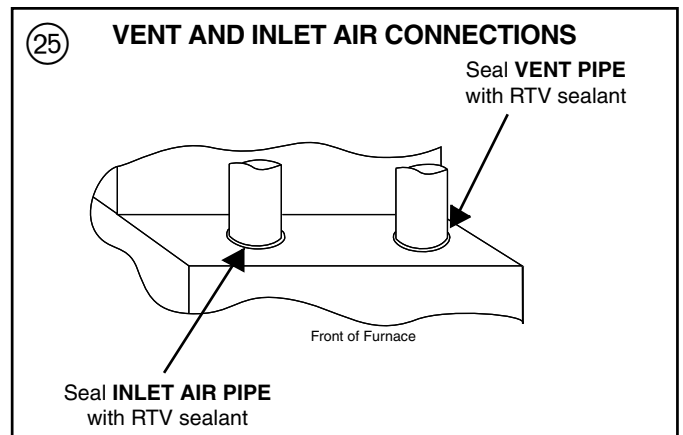

Installer's Guide

ALTITUDE	MAXIMUM TOTAL EQUIVALENT LENGTH IN FEET FOR VENT AND INLET AIR (SEE NOTES)		
	2 INCH PIPE	2.5 INCH PIPE	3 or 4 INCH PIPE
0-7,000 Feet			
UX2/DX2B060A9362A	200	200	200
UX2/DX2B080A9422A	50	120	200
UX2/DX2C100A9482A	Not Allowed	60	200
UX2/DX2D120A9602A	Not Allowed	Not Allowed	200
7,000-9,500 Feet			
UX2/DX2B060A9362A	100	100	100
UX2/DX2B080A9422A	25	60	100
UX2/DX2C100A9482A	Not Allowed	30	100
UX2/DX2D120A9602A	Not Allowed	Not Allowed	100
9,500-12,000 Feet			
UX2/DX2B060A9362A	50	50	50
UX2/DX2B080A9422A	Not Allowed	30	50
UX2/DX2C100A9482A	Not Allowed	Not Allowed	50
UX2/DX2D120A9602A	Not Allowed	Not Allowed	50

NOTES: * - First letter may be "A" or "T"

1. Minimum vent length for all models: 3' horizontal or 3' vertical.
2. DO NOT MIX PIPE DIAMETERS IN THE SAME LENGTH OF PIPE OUTSIDE THE FURNACE CABINET (Except adapters at the top of the furnace). If different inlet and vent pipe sizes are used, the vent pipe must adhere to the maximum length limit shown in the table above (See note 6 below for exception). The inlet pipe can be of a larger diameter, but never smaller than the vent pipe.
3. MAXIMUM PIPE LENGTHS MUST NOT BE EXCEEDED! THE LENGTH SHOWN IS NOT A COMBINED TOTAL, IT IS THE MAXIMUM LENGTH OF EACH (Vent or Inlet air pipes).
4. One SHORT radius 90° elbow is equivalent to 10' of 3" pipe and one LONG radius elbow is equivalent to 6' of 3" pipe. One 90° elbow is equivalent to 7½' of 2½" pipe or 5' of 2" pipe. Two 45° elbows equal one 90° elbow.
5. The termination tee or bend must be included in the total number of elbows. If the BAYAIR30AVENTA termination kit is used, the equivalent length of pipe is 5 feet. BAYVENT200B equivalent length is 0 feet.
6. Pipe adapters are field supplied (except 120).
7. For Canadian applications ONLY, IPEX 196006 may be used for horizontal and vertical terminations. IPEX 081216, IPEX 081218, and IPEX 081219 may only be used for horizontal vent terminations. Equivalent lengths are IPEX 196009 = 5 feet, IPEX 081216 = 11 feet, IPEX 081218 = 16 feet, and IPEX 081219 = 21 feet

HORIZONTAL INSTALLATION (Upflow / Horizontal or Downflow / Horizontal)

NOTE:
In horizontal venting when the factory supplied "off-set" (2X3 reducing coupling) is used for 3" vent pipe installation, make sure the marking "Top" is located on the top side of the pipe. The straight side must be on bottom for proper condensate drainage. This coupling is factory supplied only with the following models: *UC120 & *DC120, *UX120 & *UY120 *UX100 & *UY100, *UX808C960, and all *DX & *DY models.

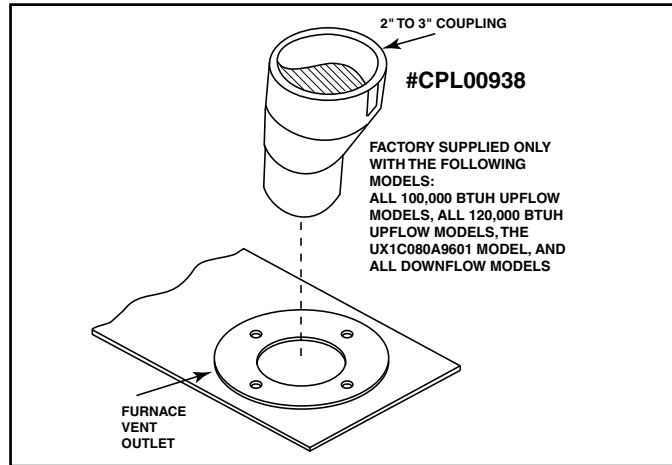
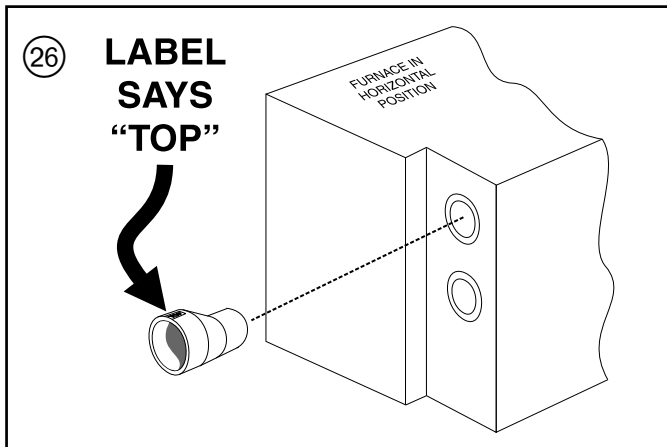

CAUTION

The vent for this appliance shall not terminate

- (1) Over public walways; or
- (2) Near soffit vents or crawl space vents or other areas where condensate or vapor could create a nuisance or hazard or cause property damage; or
- (3) Where condensate vapor could cause damage or could be detrimental to the operation of regulators, relief valves, or other equipment.

27

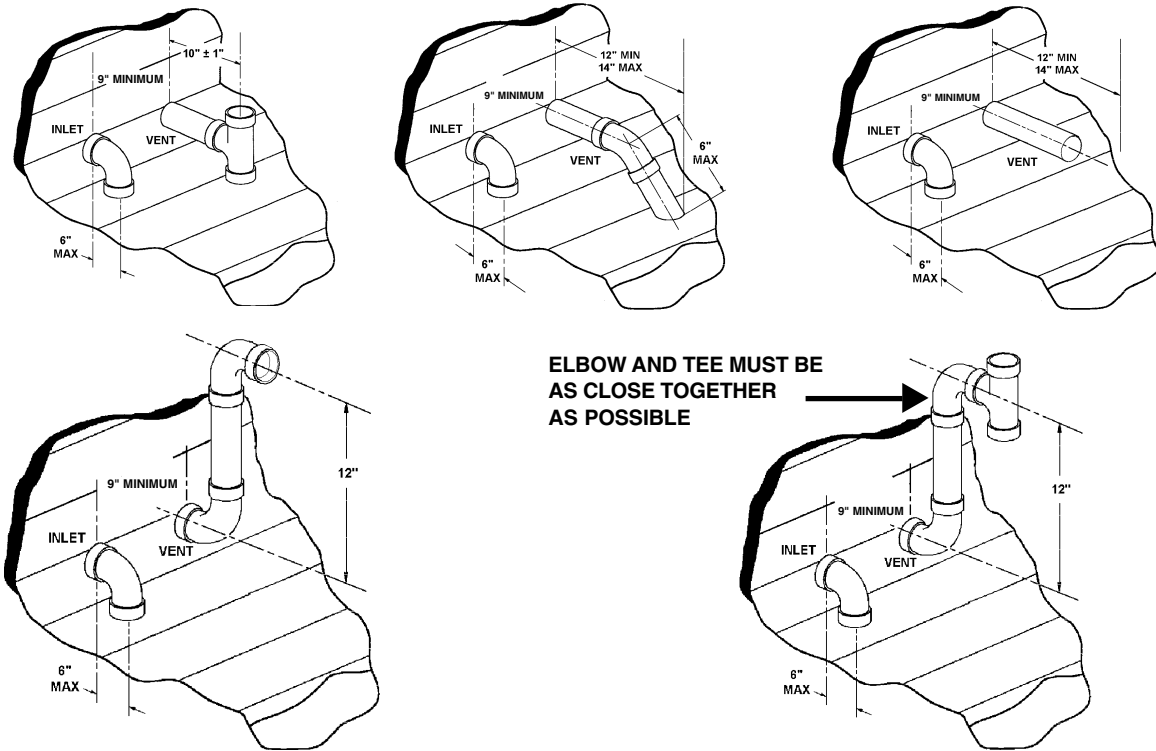

ELBOW AND TEE MUST BE AS CLOSE TOGETHER AS POSSIBLE

POSSIBLE CONFIGURATIONS FOR TWO PIPE VENTING SYSTEMS

28

NOTE: VENT AND INLET MUST BE SUPPORTED AT A MAXIMUM OF 3' INTERVALS

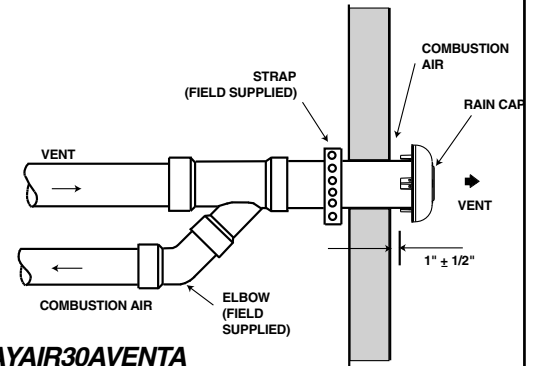
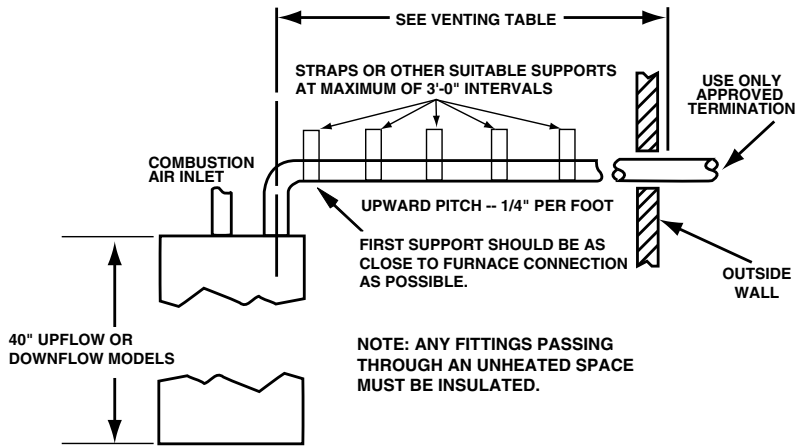

BAYAIR30AVENTA

For Canadian applications only, IPEX 196006, IPEX 081216, IPEX 081218, and IPEX 081219 may be used for horizontal vent terminations.

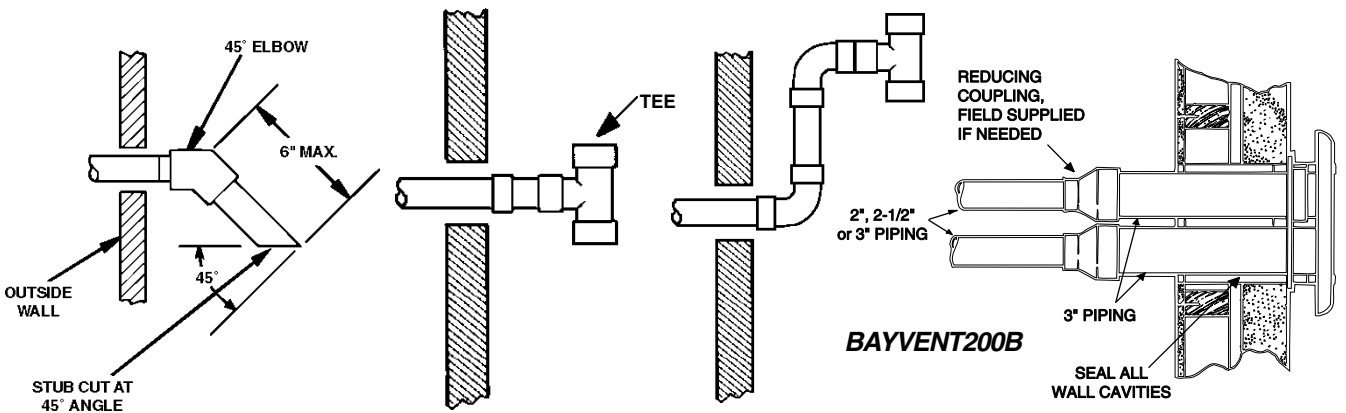

BAYVENT200B

SEAL ALL WALL CAVITIES

Installer's Guide

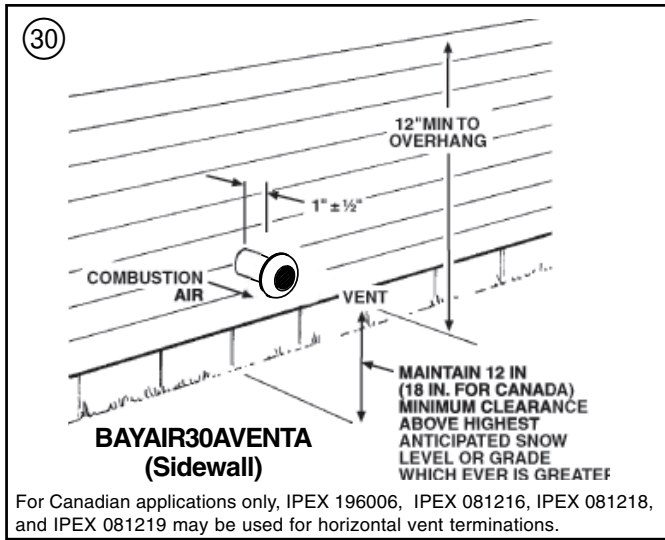
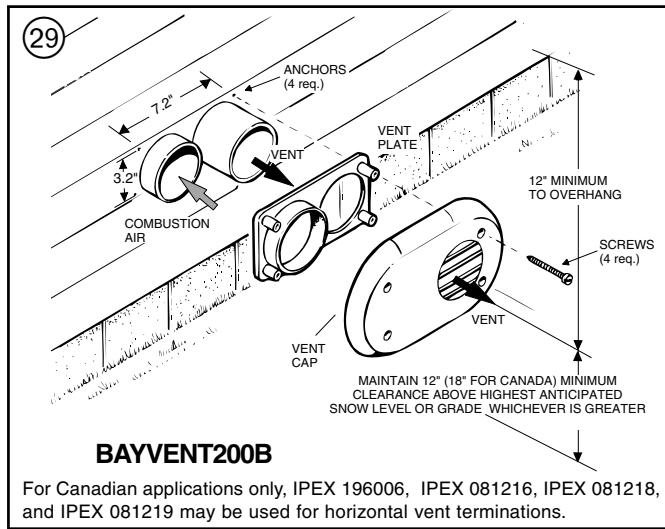

CAUTION

When the vent pipe is exposed to temperatures below freezing, i.e., when it passes through unheated spaces, etc., the pipe must be insulated with 1/2 inch (22.7 mm) thick Armaflex-type insulation or equal.

If the space is heated sufficiently to prevent freezing, then the insulation would not be required. If domestic water pipes are not protected from freezing then it is assumed the space meets the condition of a heated space.

HORIZONTAL VENTING THROUGH WALL
 These furnaces may be installed as direct vent (as shipped) or as nondirect vent. Installation must conform to national, state, and local codes.

The vent & inlet terminals must be located at least 12" minimum above normally expected snow accumulation level (18" minimum in Canadian applications).

Avoid areas where staining or condensate drippage may be a problem.

Location of the vent/wind terminal should be chosen to meet the requirements of Figure 39 for either direct or nondirect vent applications.

PITCH — Venting through the wall must maintain 1/4" per foot pitched upward to insure that condensate drains back to the furnace.

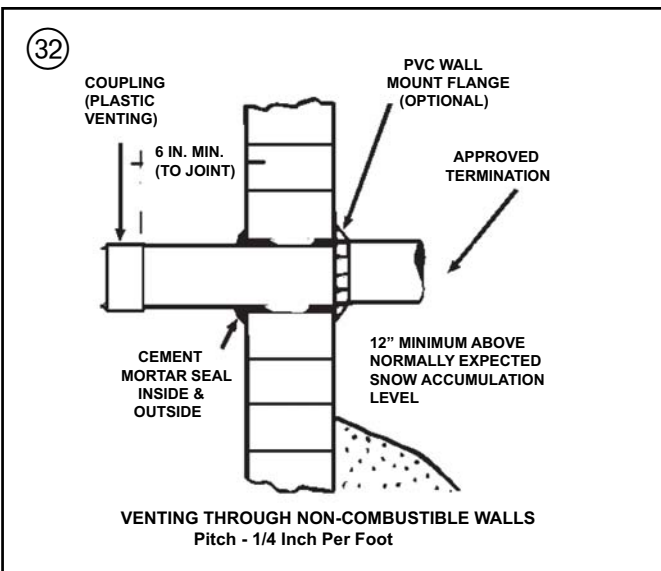
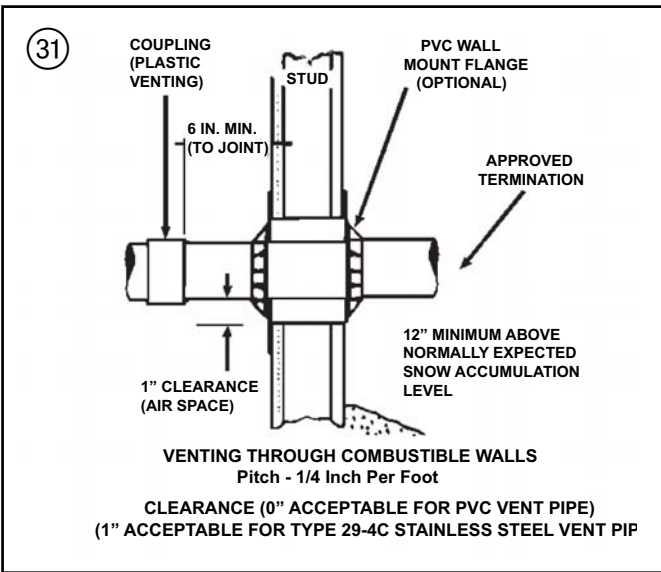

FLUE GAS DEGRADATION — The moisture content of the flue gas may have a detrimental effect on some building materials. This can be avoided by using the roof or chimney venting option. When wall venting is used on any surface that can be affected by this moisture, it is recommended that a corrosion resistant shield (24 inches square) be used behind the vent terminal. This shield can be wood, plastic, sheet metal, etc. Also, silicone caulk all cracks, seams and joints within 3 feet of the vent terminal.

COMBUSTIBLE MATERIAL WALL
 A minimum clearance of 1" to combustible materials must be maintained when using single wall stainless steel venting. See Figure 31.

Shield material to be a minimum of 24 gauge stainless or aluminized sheet metal. Minimum dimensions are 12"x12". Shield must be fastened to both inside and outside of wall. Use screws or anchor type fasteners suited to the outside or inside wall surfaces.

NONCOMBUSTIBLE MATERIAL WALL
 The hole through the wall must be large enough to maintain pitch of vent and properly seal.
 Use cement mortar seal on inside and outside of wall. See Figure 32.

33

SUPPORT HORIZONTAL PIPE EVERY 3' 0" WITH THE FIRST SUPPORT AS CLOSE TO THE FURNACE AS POSSIBLE. INDUCED DRAFT BLOWER, HOUSING, AND FURNACE MUST NOT SUPPORT THE WEIGHT OF THE FLUE PIPE.

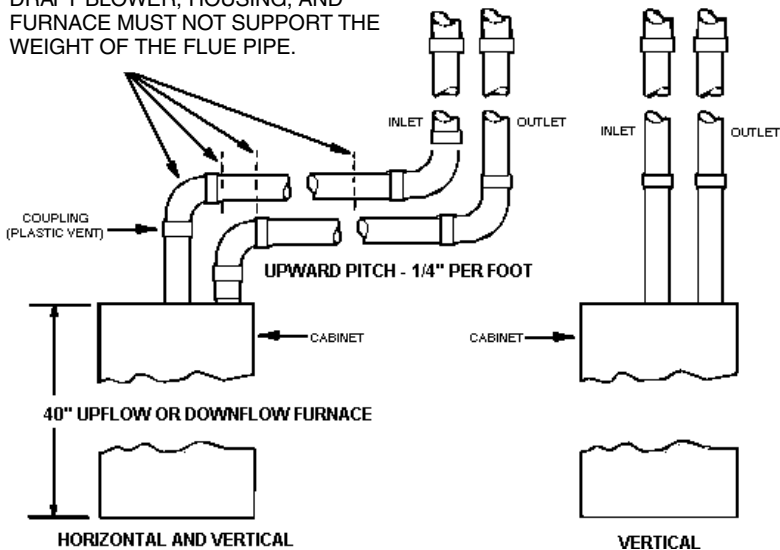

34

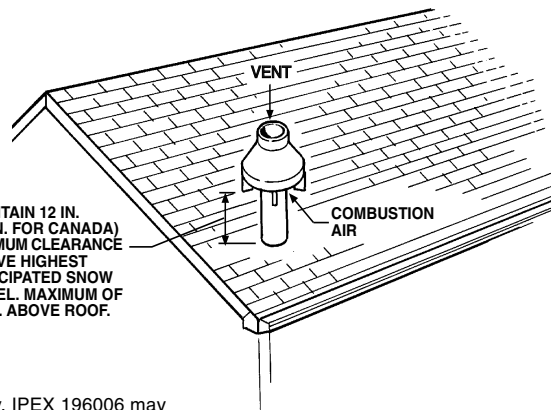
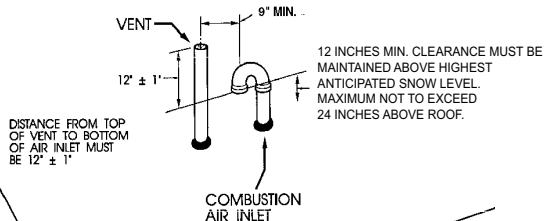

For Canadian applications only, IPEX 196006 may be used for horizontal vent terminations.

35

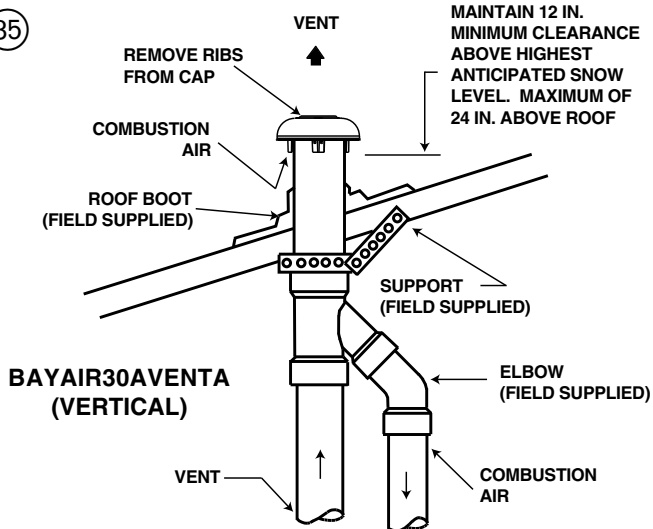

For Canadian applications only, IPEX 196006 may be used for horizontal vent terminations.

36

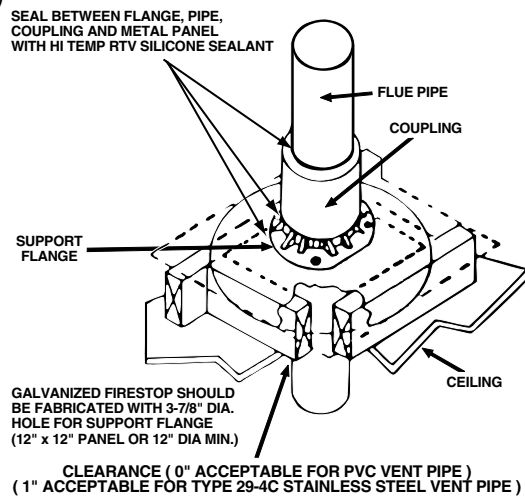

VENTING THROUGH CEILING

Installer's Guide

VENTING THROUGH THE ROOF

When penetrating roof with a 2" PVC vent pipe, a 2" electrical conduit flashing may be used for a weather tight seal. Lubricate flexible seal on flashing before PVC pipe is pushed through the seal. (Field Supplied)

NOTE:

No vent cap as shown in Figure 34 is the preferred method for vertical vent termination in extremely cold climates.

In extreme climate conditions, insulate the exposed pipe above the roof line with Armaflex type insulation.

VENT FITTING MATERIAL – STAINLESS STEEL

Gas and liquid tight single wall metal vent fitting, designed for resistance to corrosive flue condensate such as Type 29-4C MUST be used throughout.

These fittings and fitting accessories are to be supplied locally.

DIRECTION OF STAINLESS STEEL FITTING

All stainless steel fitting must be installed with male end towards the furnace.

All horizontal stainless steel sections must be positioned with the seam on top.

All long horizontal sections must be supported to prevent sagging.

All pipe joints must be fastened and sealed to prevent escape of combustion products into the building.

37

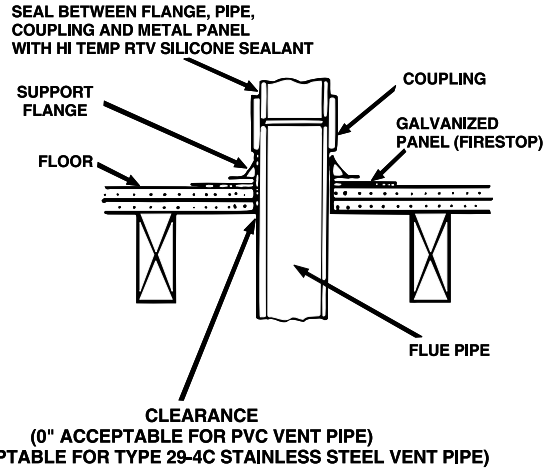

38

PVC PLASTIC VENTING – ONLY THROUGH UNUSED CHIMNEY

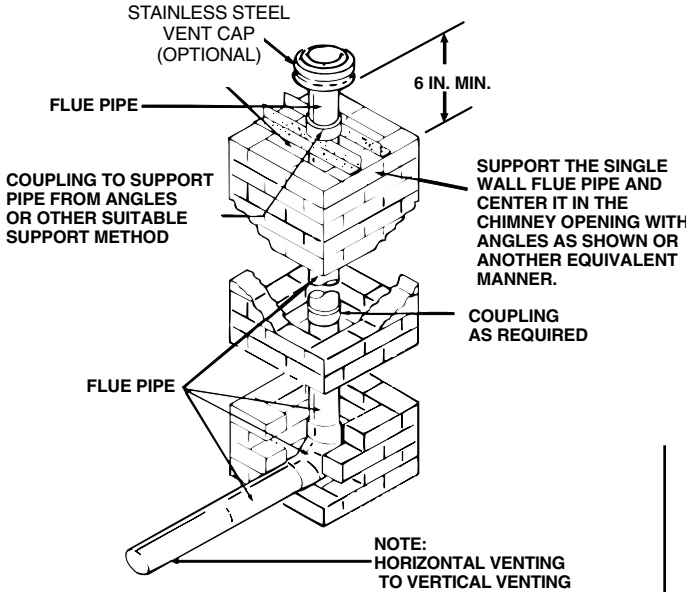

CAUTION
Do not run vent through chimney for wood burning or oil furnaces or incinerators or any other gas appliance.

IMPORTANT –
The single wall flue pipe joints must be sealed.
The 90° elbow connection to vertical pipe must be sealed to prevent condensate leakage to base of masonry chimney.

TYPE 29-4C STAINLESS STEEL VENTING – USED THROUGH CHIMNEY THAT VENTS ANOTHER GAS APPLIANCE

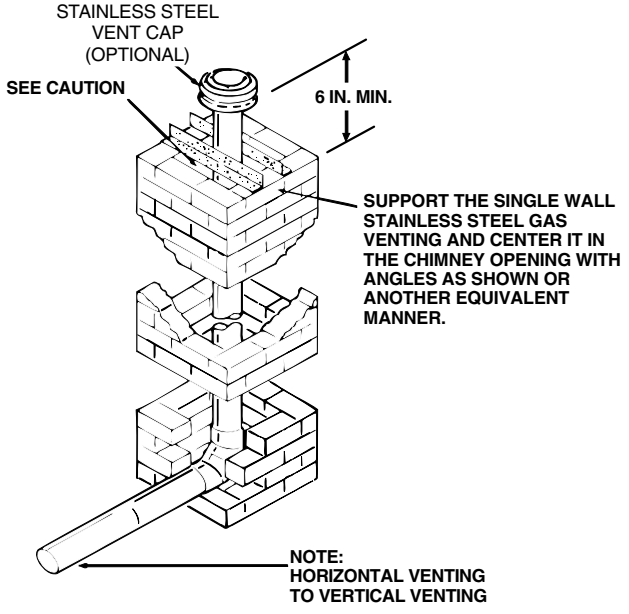

CAUTION

Do not run vent through chimney for wood burning or oil furnaces or incinerators.

If remaining free area between single wall flue pipe and masonry chimney is to be used for another gas appliance venting area must be sufficient to vent that appliance and that appliance must be connected to chimney with separate entry openings.

IMPORTANT –
The single wall flue pipe joints must be sealed.
The 90° elbow connection to vertical pipe must be sealed to prevent condensate leakage to base of masonry chimney.

VENTING ROUTED THROUGH A MASONRY CHIMNEY

39

HORIZONTAL VENT CLEARANCES

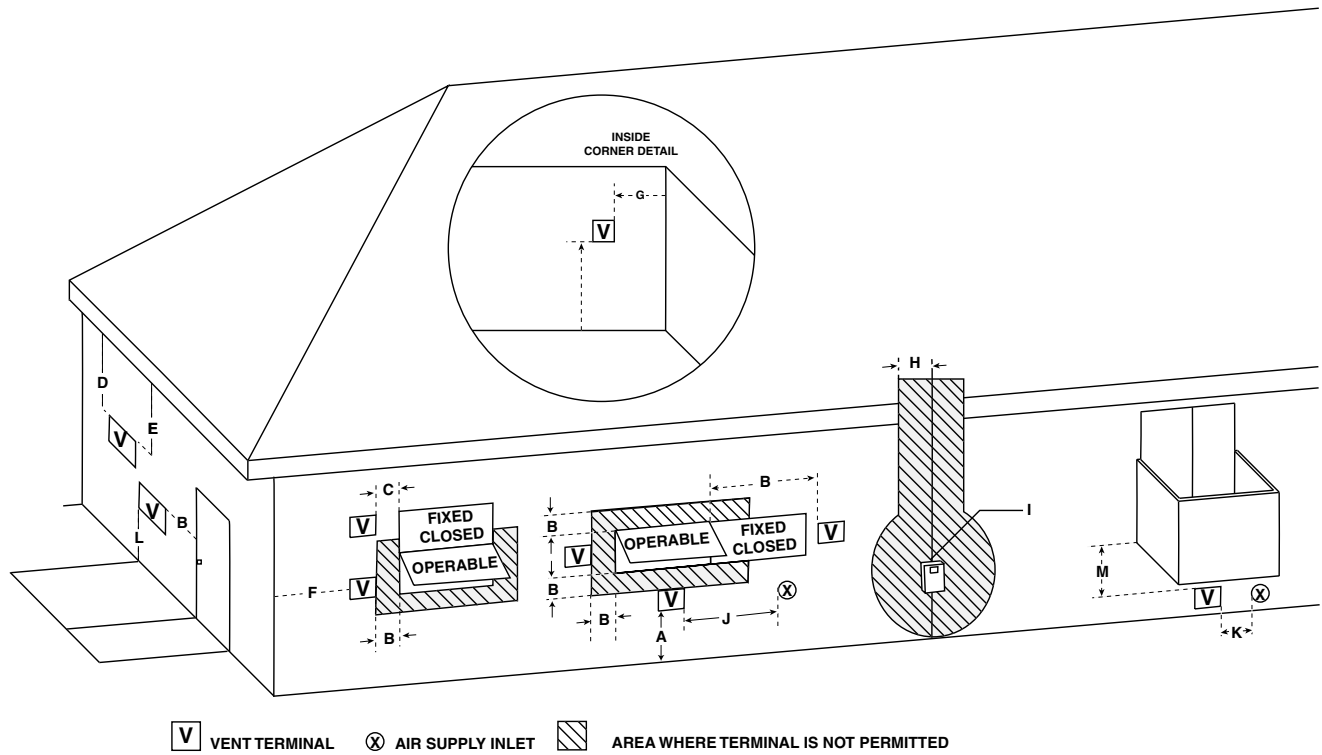

		Canadian Installations	US Installations
A=	Clearance above grade, veranda, porch, deck, or balcony	12 inches (30 cm)	12 inches (30 cm)
B=	Clearance to window or door that may be opened	6 inches (15 cm) for appliances \leq 10,000 Btuh (3 kw), 12 inches (30 cm) for appliances $>$ 10,000 Btuh (3 kw) and \leq 100,000 Btuh (30 kw), 36 inches (91 cm) for appliances $>$ 100,000 Btuh (30 kw)	4 feet (1.2m) below or to the side of opening; 1 foot (0.3m) above opening.
C=	Clearance to permanently closed window	*	*
D=	Vertical clearance to ventilated soffit located above the terminal within a horizontal distance of 2 feet (61 cm) from the center line of the terminal	*	*
E=	Clearance to unventilated soffit	*	*
F=	Clearance to outside corner	*	*
G=	Clearance to inside corner	*	*
H=	Clearance to each side of center line extended above meter/regulator assembly	3 feet (91 cm) with a height 15 feet (4.5 m) above the meter/regulator assembly	*
I=	Clearance to service regulator vent outlet	3 feet (91 cm)	*
J=	Clearance to nonmechanical air supply inlet to building or the combustion air inlet to any other appliance	6 inches (15 cm) for appliances \leq 10,000 Btuh (3 kw), 12 inches (30 cm) for appliances $>$ 10,000 Btuh (3 kw) and \leq 100,000 Btuh (30 kw), 36 inches (91 cm) for appliances $>$ 100,000 Btuh (30 kw)	4 feet (1.2 m) below or to side of opening; 1 foot (300 m) above opening
K=	Clearance to a mechanical air supply inlet	6 feet (1.83m)	3 feet (91 cm) above if within 10 feet (3m) horizontally
L=	Clearance above a paved sidewalk or paved driveway located on public property	7 feet (2.13 m) †	7 feet (2.13 m)
M=	Clearance under veranda, porch, deck, or balcony	12 inches (30 cm) ‡	*

Notes:

- In accordance with the current CSA B149.1 Natural Gas and Propane Installation Code.
- In accordance with the current ANSI Z223.1/NFPA 54 National Fuel Gas Code.
- † A vent shall not terminate directly above a sidewalk or paved driveway that is located between two single family dwelling and serves both dwellings.
- ‡ Permitted only if veranda, porch, deck, or balcony is fully open on a minimum of two sides beneath the floor.
- * Clearance in accordance with local installation codes and the requirements of the gas supplier and the manufacturer's Installation Instructions.

Installer's Guide

		Canadian Installations	US Installations
A=	Clearance above grade, veranda, porch, deck, or balcony	12 inches (30 cm)	12 inches (30 cm)
B=	Clearance to window or door that may be opened	6 inches (15 cm) for appliances \leq 10,000 Btuh (3 kw), 12 inches (30 cm) for appliances $>$ 10,000 Btuh (3 kw) and \leq 100,000 Btuh (30 kw), 36 inches (91 cm) for appliances $>$ 100,000 Btuh (30 kw)	6 inches (15 cm) for appliances \leq 10,000 Btuh (3 kw), 9 inches (23 cm) for appliances $>$ 10,000 Btuh (3 kw) and \leq 50,000 Btuh (15 kw), 12 inches (30 cm) for appliances $>$ 50,000 Btuh (15 kw)
C=	Clearance to permanently closed window	*	*
D=	Vertical clearance to ventilated soffit located above the terminal within a horizontal distance of 2 feet (61 cm) from the center line of the terminal	*	*
E=	Clearance to unventilated soffit	*	*
F=	Clearance to outside corner	*	*
G=	Clearance to inside corner	*	*
H=	Clearance to each side of center line extended above meter/regulator assembly	3 feet (91 cm) with a height 15 feet (4.5 m) above the meter/regulator assembly	*
I=	Clearance to service regulator vent outlet	3 feet (91 cm)	*
J=	Clearance to nonmechanical air supply inlet to building or the combustion air inlet to any other appliance	6 inches (15 cm) for appliances \leq 10,000 Btuh (3 kw), 12 inches (30 cm) for appliances $>$ 10,000 Btuh (3 kw) and \leq 100,000 Btuh (30 kw), 36 inches (91 cm) for appliances $>$ 100,000 Btuh (30 kw)	6 inches (15 cm) for appliances \leq 10,000 Btuh (3 kw), 9 inches (23 cm) for appliances $>$ 10,000 Btuh (3 kw) and \leq 50,000 Btuh (15 kw), 12 inches (30 cm) for appliances $>$ 50,000 Btuh (15 kw)
K=	Clearance to a mechanical air supply inlet	6 feet (1.83m)	3 feet (91 cm) above if within 10 feet (3m) horizontally
L=	Clearance above a paved sidewalk or paved driveway located on public property	7 feet (2.13 m) †	*
M=	Clearance under veranda, porch, deck, or balcony	12 inches (30 cm) ‡	*

Notes:

1. In accordance with the current CSA B149.1 Natural Gas and Propane Installation Code.
 2. In accordance with the current ANSI Z223.1/NFPA 54 National Fuel Gas Code.
- †. A vent shall not terminate directly above a sidewalk or paved driveway that is located between two single family dwelling and serves both dwellings.
‡. Permitted only if veranda, porch, deck, or balcony is fully open on a minimum of two sides beneath the floor.
* Clearance in accordance with local installation codes and the requirements of the gas supplier and the manufacturer's Installation Instructions.

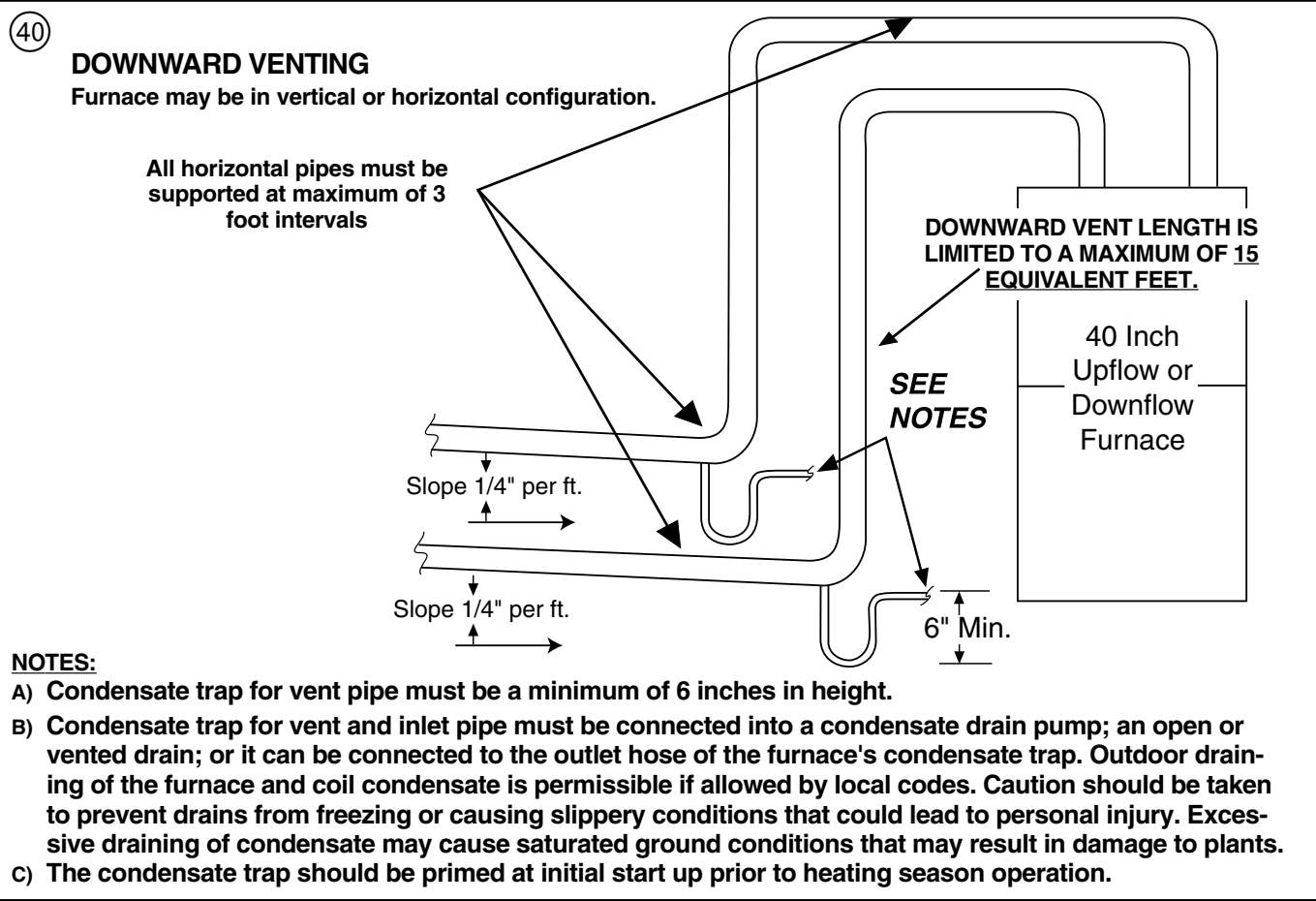

IMPORTANT:

The Commonwealth of Massachusetts requires compliance with regulation 248 CMR 4.00 and 5.00 for installation of through – the – wall vented gas appliances as follows:

For all side wall horizontally vented gas fueled equipment installed in every dwelling, building or structure used in whole or in part for residential purposes, including those owned or operated by the Commonwealth and where the side wall exhaust vent termination is less than seven (7) feet above finished grade in the area of the venting, including but not limited to decks and porches, the following requirements shall be satisfied:

1. **INSTALLATION OF CARBON MONOXIDE DETECTORS.** At the time of installation of the side wall horizontal vented gas fueled equipment, the installing plumber or gasfitter shall observe that a hard wired carbon monoxide detector with an alarm and battery back-up is installed on the floor level where the gas equipment is to be installed. In addition, the installing plumber or gasfitter shall observe that a battery operated or hard wired carbon monoxide detector with an alarm is installed on each additional level of the dwelling, building or structure served by the side wall horizontal vented gas fueled equipment. It shall be the responsibility of the property owner to secure the services of qualified licensed professionals for the installation of hard wired carbon monoxide detectors

a. In the event that the side wall horizontally vented gas fueled equipment is installed in a crawl space or an attic, the hard wired carbon monoxide detector with alarm and battery back-up may be installed on the next adjacent floor level.

b. In the event that the requirements of this subdivision can not be met at the time of completion of installation, the owner shall have a period of thirty (30) days to comply with the above requirements; provided, however, that during said thirty (30) day period, a battery operated carbon monoxide detector with an alarm shall be installed.

2. **APPROVED CARBON MONOXIDE DETECTORS.** Each carbon monoxide detector as required in accordance with the above provisions shall comply with NFPA 720 and be ANSI/UL 2034 listed and IAS certified.

3. **SIGNAGE.** A metal or plastic identification plate shall be permanently mounted to the exterior of the building at a minimum height of eight (8) feet above grade directly in line with the exhaust vent terminal for the horizontally vented gas fueled heating appliance or equipment. The sign shall read, in print size no less than one-half (1/2) inch in size, "GAS VENT DIRECTLY BELOW. KEEP CLEAR OF ALL OBSTRUCTIONS".

4. **INSPECTION.** The state or local gas inspector of the side wall horizontally vented gas fueled equipment shall not approve the installation unless, upon inspection, the inspector observes carbon monoxide detectors and signage installed in accordance with the provisions of 248 CMR 5.08(2)(a)1 through 4.

This appliance requires a special venting system. If BAYAIR30AVENTA or BAYVENT200B are used, a copy of the installation instructions for the kit shall remain with the appliance or equipment at the completion of installation. The venting system installation instructions can be obtained from the manufacturer by writing to the following address:

Trane
6200 Troup Highway
Tyler, TX 75707
Attention: Manager of Field Operations Excellence

IMPORTANT:

Products installed in Canada must use vent systems that are certified to the Standard for Type BH Gas Venting Systems (ULC S636) for Class II-A venting systems (up to 65°C). Components of the vent system must not be interchanged with other vent systems or unlisted pipe or fittings. Plastic components, specified primers, and glues must be from a single system manufacturer and not intermixed with other system manufacturer's vent system parts. In addition, the first three feet of the vent pipe must be visible for inspection.

Installer's Guide

CONDENSATE DRAIN INSTRUCTIONS

⚠ CAUTION

It is recommended that a drain pan be installed under the furnace to prevent property damage or personal injury from leaking condensate.

VERTICAL APPLICATIONS

Upflow furnace - The connection tubing for left and right side drainage is shipped in the blower compartment. Install the connection tubing from the trap to the side of the unit and trim all excess tubing to avoid kinks.

Downflow furnace - The furnace is shipped with the left side drainage setup. To change the right side drain, remove the drain lines from the trap, rotate the trap 180° so it exits to the right, reconnect the lines, and run a 1/2" CPVC pipe from the trap out through the right side knock-out. Use RTV silicone sealant to connect the CPVC pipe to the trap for ease of removing to clean the trap.

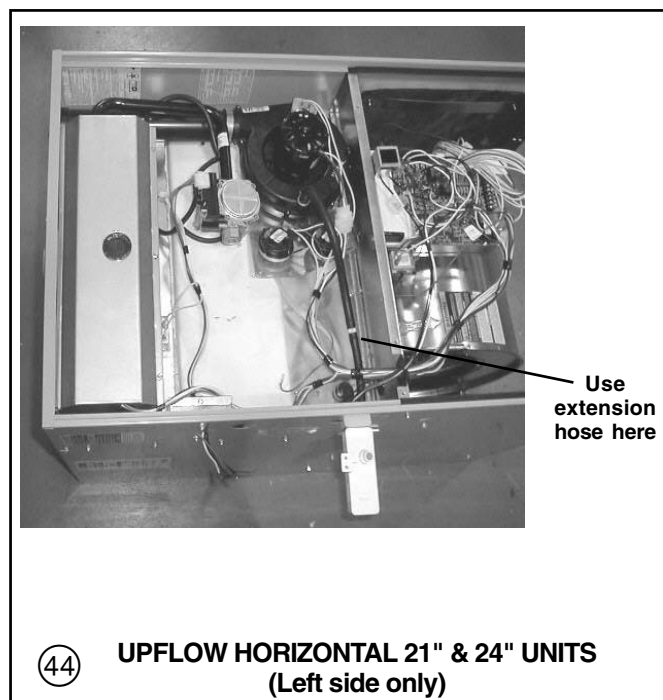
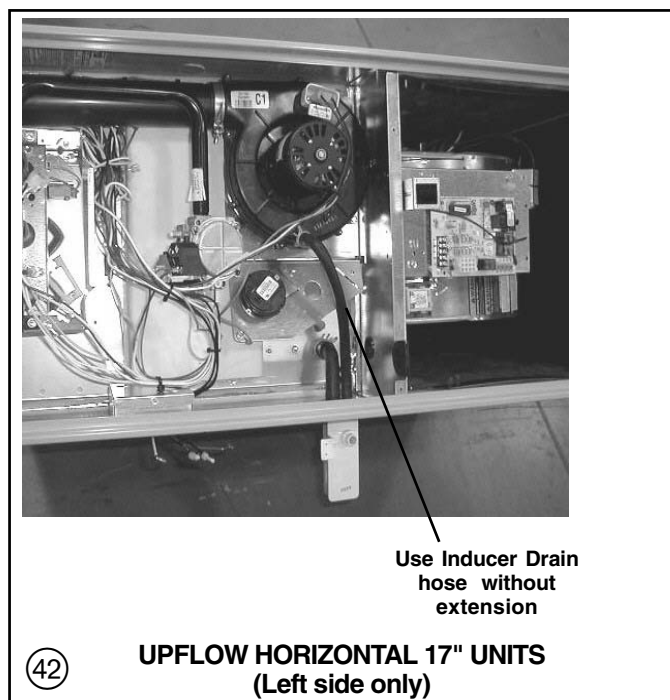
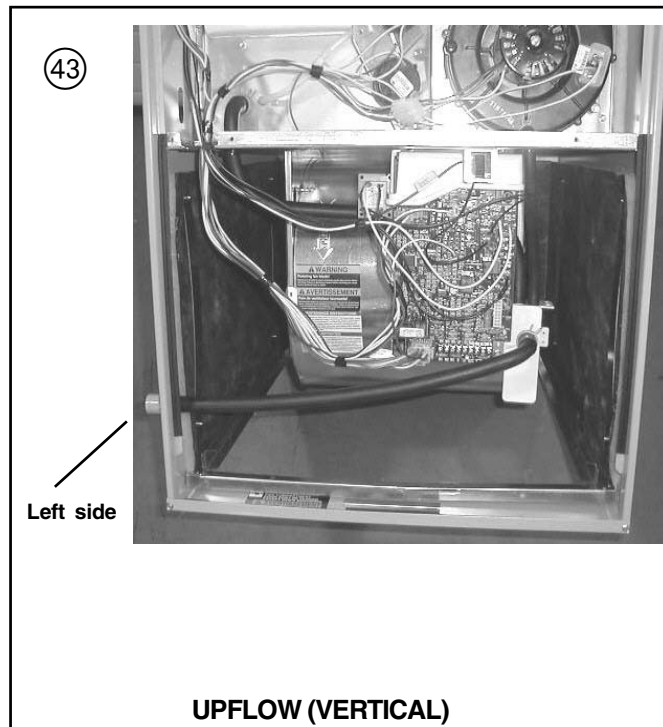
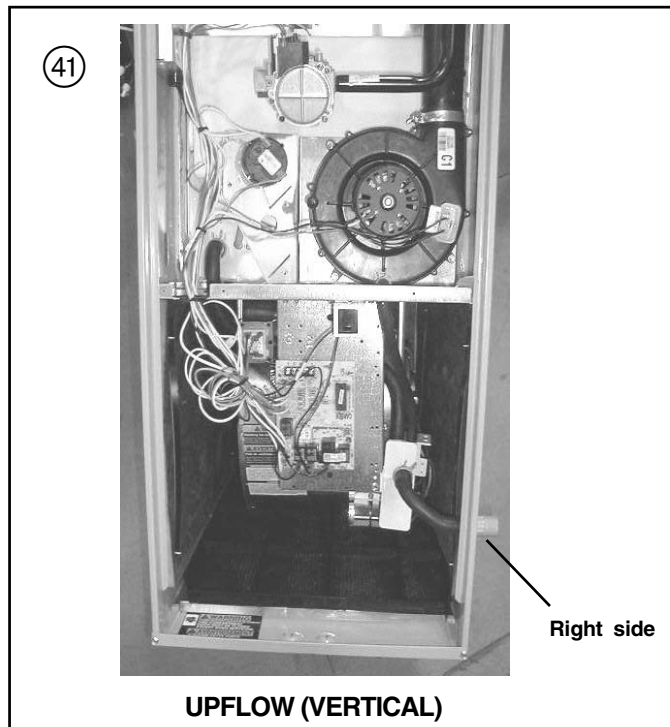

HORIZONTAL APPLICATIONS

Upflow and Downflow furnaces - All horizontal applications are left side only. It is always recommended that the auxiliary drain pan be installed under a horizontally installed evaporator and/or 90% gas furnace. Connect the auxiliary drain pan to a separate drain line (no trap is needed in this line).

The trap must be repositioned to the exterior of the cabinet. Remove the trap from its present location and reposition the trap outside of the unit, through the long circular hole, next to the secondary recuperative cell. Remove the larger drain line (from the secondary cell) and trim to fit between the secondary cell and the new trap location. On upflow units, plug the hole in the blower deck where the tube went through.

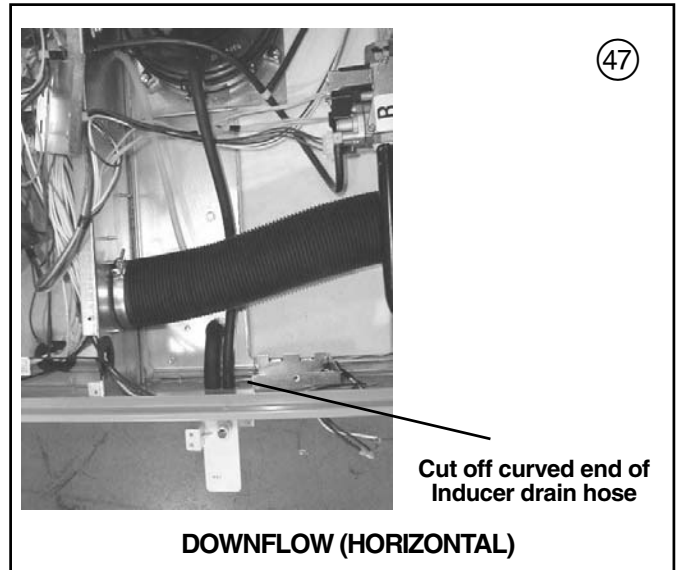
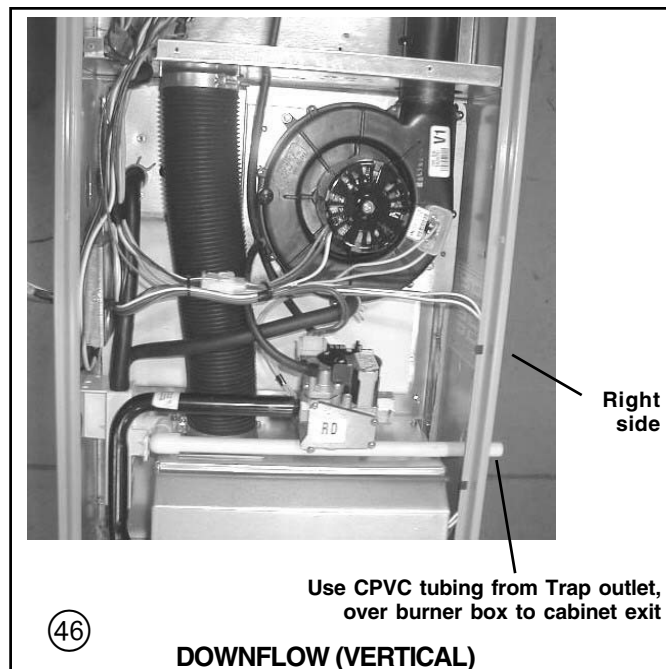
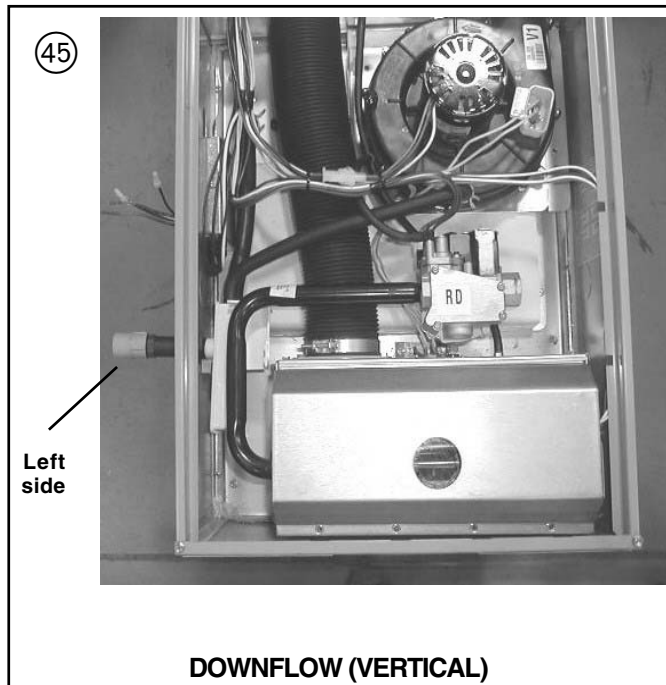

Remove the hose from the induced blower and reposition into the other drain tap of the inducer, which is located 90° clockwise around the inducer. Move the cap from that drain tap to the unused drain tap. On upflow units, plug the hole in the blower deck where the tube went through. This tube on downflow units will need to be cut to fit between the inducer and the trap. On upflow units, this tube may need to be extended, using the tubing shipped with the furnace.

Connections must be made to an **OPEN/VENTED DRAIN**. Outdoor draining of the furnace and coil condensate is permissible if allowed by local codes. Caution should be taken to prevent drains from freezing or causing slippery conditions that could lead to personal injury. Excessive draining of condensate may cause saturated ground conditions that may result in damage to plants.

NOTE:

Use 1/2" or larger PVC or CPVC pipe and fittings as required for drain connections (fittings, pipe and solvent cement not provided).

NOTE:

A corrosion resistant condensate pump must be used if a pump is required for a specific drain system.

IMPORTANT:

The condensate drain should be installed with provisions to prevent winter freeze-up of the condensate drain line. Frozen condensate will block drains, resulting in furnace shutdown. If the drain line cannot be installed in a conditioned space, then UL listed heat tape should be applied as required to prevent freezing (per manufacturer's instructions). The heat tape should be rated at 5 or 6 watts per foot at 120 volts. Self-regulating (preferred) or thermostatically controlled heat tape is required.

Evaporator and furnace condensate drain piping may be manifolded together. A primary drain vent stack must be installed and terminated below the outlet of the secondary heat exchanger drain connection to prevent water from damaging furnace controls if the primary drain outlet plugs up. Where the furnace is installed above a finished ceiling, the primary drain vent stack must be installed such that overflow from the vent stack opening will flow into an auxiliary drain pan in order to prevent water damage to the finished ceiling below.

Installer's Guide

48

If upflow furnace is installed over a finished ceiling, overflow from the primary drain vent stack must flow into an auxiliary drain pan to prevent damage to the finished ceiling below.

Primary drain vent stack must terminate below secondary heat exchanger condensate drain outlet.

To drain opening

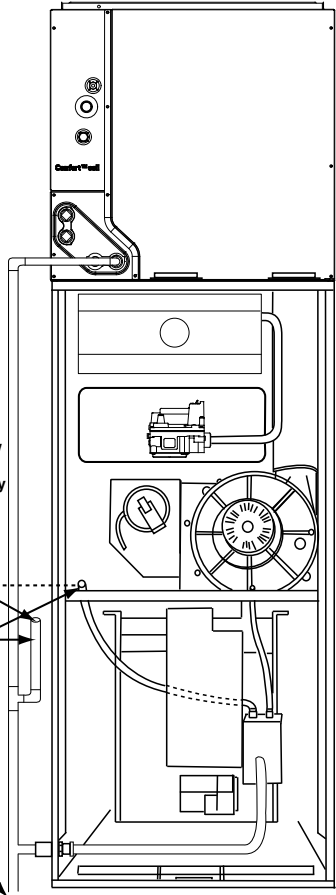

FIELD WIRING DIAGRAM FOR 2 STAGE FURNACE 1 STAGE HEATING USING A 1 STAGE HEATING THERMOSTAT NO COOLING

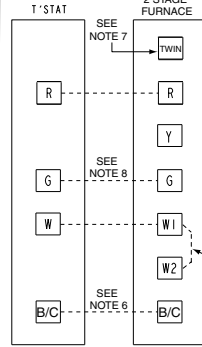

NOTES:

1. BE SURE POWER AGREES WITH EQUIPMENT NAMEPLATE(S).
2. LOW VOLTAGE (24V. WIRING) TO BE NO. 18 A.W.G. MIN..
3. GROUNDING OF EQUIPMENT MUST COMPLY WITH LOCAL CODES.
4. SET THERMOSTAT HEAT ANTICIPATOR PER UNIT WIRING DIAGRAM.
5. THESE LEADS PROVIDE 115 V. POWER FOR CONNECTION OF ELECTRONIC AIR CLEANER AND HUMIDIFIER MAX. LOAD 1.0 AMPS EACH.
6. THIS CONNECTION IS ONLY USED FOR THERMOSTATS REQUIRING CONNECTION TO THE 24 V. POWER SUPPLY. (COMMON)
7. SEE TWINNING CONNECTION DIAGRAMS FOR PROPER CONNECTIONS WHEN USING THIS FEATURE.
8. WHEN A HEATING THERMOSTAT (WITHOUT FAN SWITCH) IS USED, NO WIRING ON "G" TERMINAL OF IFC IS USED.
9. W1 AND W2 MUST BE JUMPED TOGETHER FOR PROPER OPERATION. SECOND STAGE HEATING WILL BEGIN 10 MINUTES AFTER FIRST STAGE.

INTER-COMPONENT WIRING

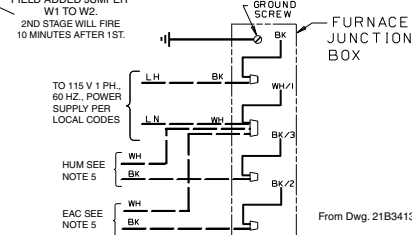
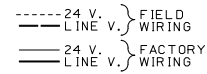

From Dwg. 21B341333 Rev. 1

FIELD WIRING DIAGRAM FOR 2 STAGE FURNACE 2 STAGE HEATING USING A 2 STAGE HEATING THERMOSTAT NO COOLING

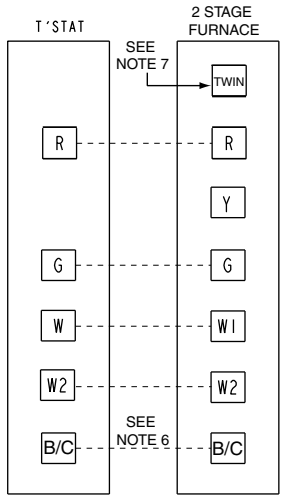

NOTES:

1. BE SURE POWER AGREES WITH EQUIPMENT NAMEPLATE(S).
2. LOW VOLTAGE (24V. WIRING) TO BE NO. 18 A.W.G. MIN..
3. GROUNDING OF EQUIPMENT MUST COMPLY WITH LOCAL CODES.
4. SET THERMOSTAT HEAT ANTICIPATOR PER UNIT WIRING DIAGRAM.
5. THESE LEADS PROVIDE 115 V. POWER FOR CONNECTION OF ELECTRONIC AIR CLEANER AND HUMIDIFIER MAX. LOAD 1.0 AMPS EACH.
6. THIS CONNECTION IS ONLY USED FOR THERMOSTATS REQUIRING CONNECTION TO THE 24 V. POWER SUPPLY. (COMMON)
7. SEE TWINNING CONNECTION DIAGRAMS FOR PROPER CONNECTIONS WHEN USING THIS FEATURE.

INTER-COMPONENT WIRING

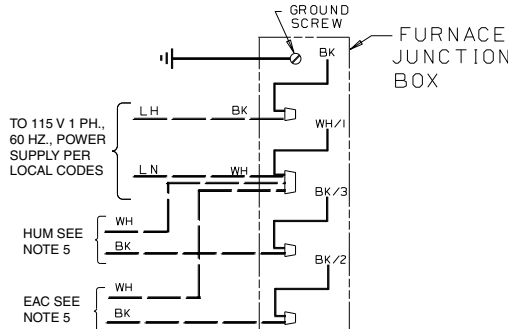
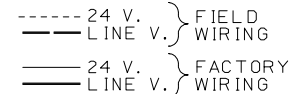

From Dwg. 21B342024 Rev. 0

FIELD WIRING DIAGRAM FOR 2 STAGE FURNACE 2 STAGE HEATING, 1 STAGE COOLING USING A 2 STAGE HEATING, 1 STAGE COOLING THERMOSTAT (OUTDOOR SECTION WITHOUT TRANSFORMER)

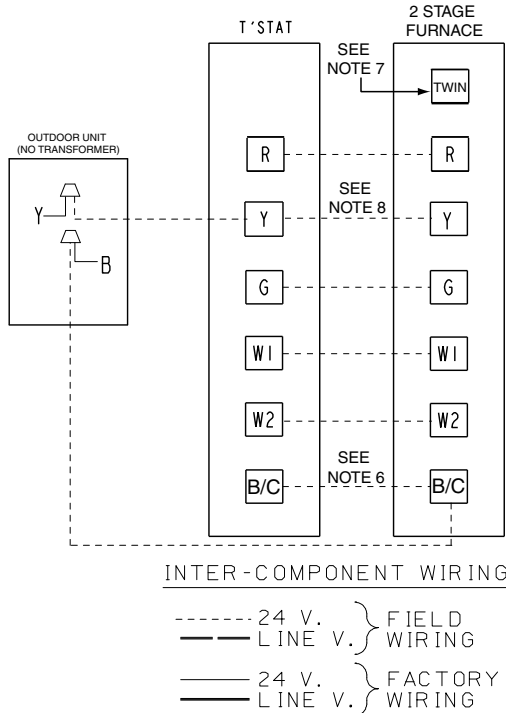

NOTES:

1. BE SURE POWER AGREES WITH EQUIPMENT NAMEPLATE(S).
2. LOW VOLTAGE (24V. WIRING) TO BE NO. 18 A.W.G. MIN..
3. GROUNDING OF EQUIPMENT MUST COMPLY WITH LOCAL CODES.
4. SET THERMOSTAT HEAT ANTICIPATOR PER UNIT WIRING DIAGRAM.
5. THESE LEADS PROVIDE 115 V. POWER FOR CONNECTION OF ELECTRONIC AIR CLEANER AND HUMIDIFIER MAX. LOAD 1.0 AMPS EACH.
6. THIS CONNECTION IS ONLY USED FOR THERMOSTATS REQUIRING CONNECTION TO THE 24 V. POWER SUPPLY. (COMMON)
7. SEE TWINNING CONNECTION DIAGRAMS FOR PROPER CONNECTIONS WHEN USING THIS FEATURE.
8. THE "Y" TERMINAL FROM THE THERMOSTAT MUST BE WIRED TO THE "Y" TERMINAL OF THE FURNACE CONTROL FOR PROPER BLOWER OPERATION DURING COOLING.

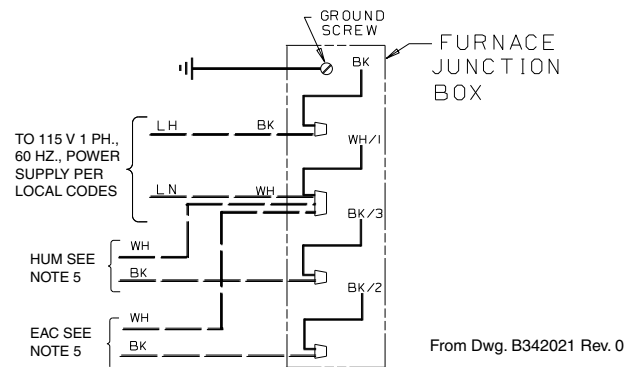

FIELD WIRING DIAGRAM FOR 2 STAGE FURNACE 2 STAGE HEATING, 1 STAGE COOLING USING A 1 STAGE HEATING, 1 STAGE COOLING THERMOSTAT (OUTDOOR SECTION WITHOUT TRANSFORMER)

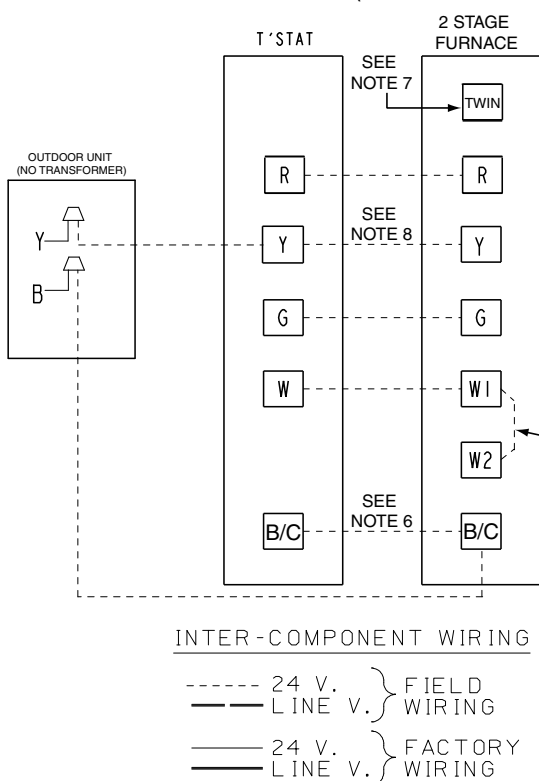

NOTES:

1. BE SURE POWER AGREES WITH EQUIPMENT NAMEPLATE(S).
2. LOW VOLTAGE (24V. WIRING) TO BE NO. 18 A.W.G. MIN..
3. GROUNDING OF EQUIPMENT MUST COMPLY WITH LOCAL CODES.
4. SET THERMOSTAT HEAT ANTICIPATOR PER UNIT WIRING DIAGRAM.
5. THESE LEADS PROVIDE 115 V. POWER FOR CONNECTION OF ELECTRONIC AIR CLEANER AND HUMIDIFIER MAX. LOAD 1.0 AMPS EACH.
6. THIS CONNECTION IS ONLY USED FOR THERMOSTATS REQUIRING CONNECTION TO THE 24 V. POWER SUPPLY. (COMMON)
7. SEE TWINNING CONNECTION DIAGRAMS FOR PROPER CONNECTIONS WHEN USING THIS FEATURE.
8. THE "Y" TERMINAL FROM THE THERMOSTAT MUST BE WIRED TO THE "Y" TERMINAL OF THE FURNACE CONTROL FOR PROPER BLOWER OPERATION DURING COOLING.
9. W1 AND W2 MUST BE JUMPED TOGETHER FOR PROPER OPERATION. SECOND STAGE HEATING WILL BEGIN 10 MINUTES AFTER FIRST STAGE.

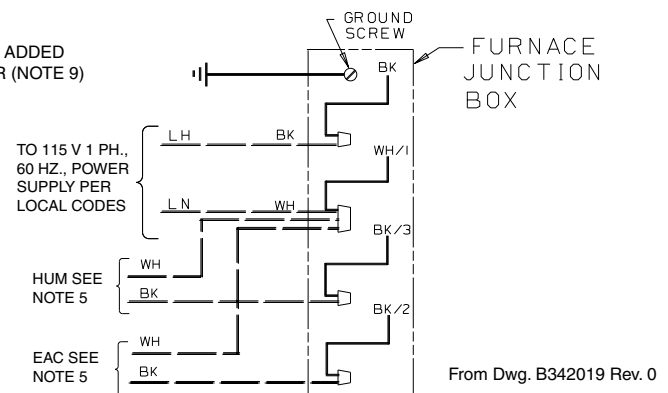

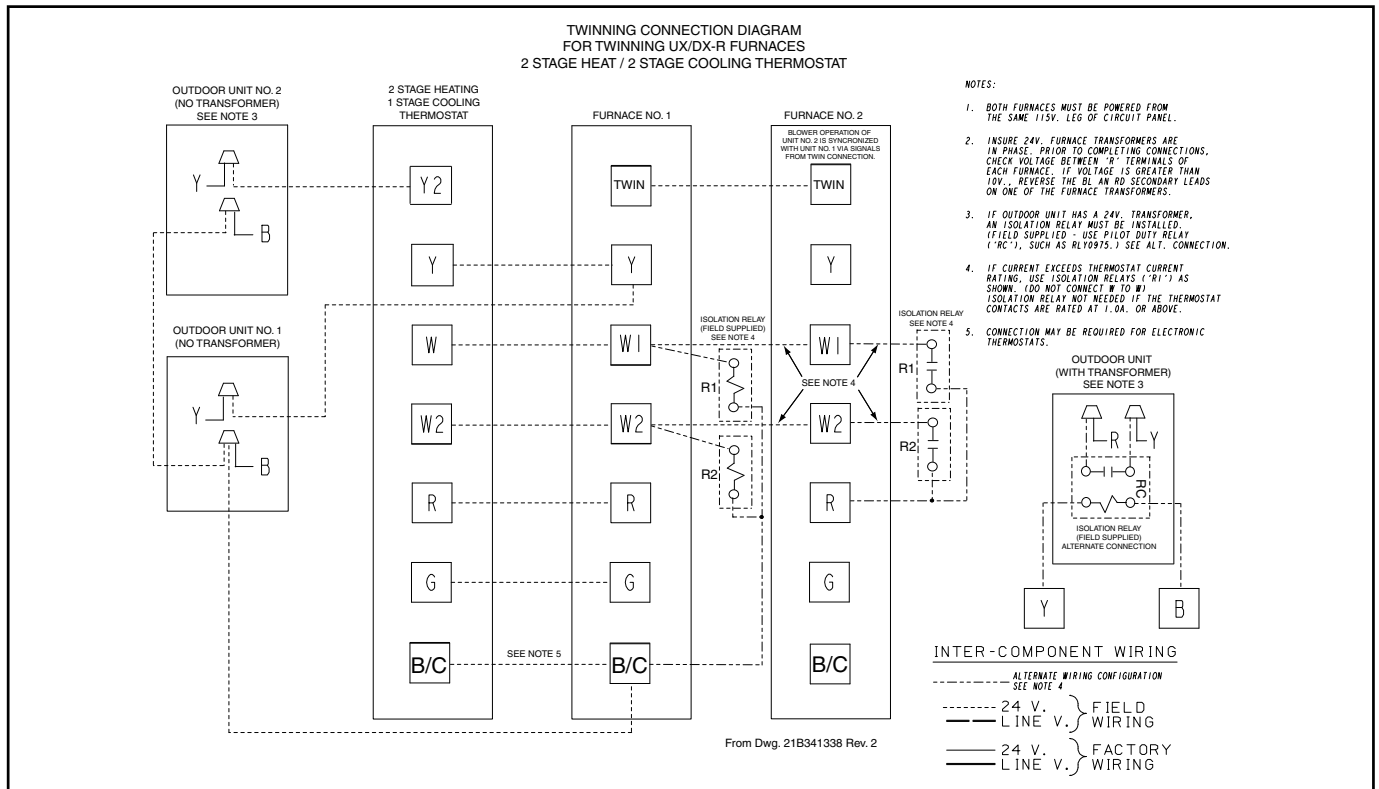

⚠ WARNING

CARBON MONOXIDE POISONING HAZARD

Failure to follow the installation instructions for the venting system being placed into operation could result in carbon monoxide poisoning or death.

ELECTRICAL CONNECTIONS

Make wiring connections to the unit as indicated on enclosed wiring diagram. As with all gas appliances using electrical power, this furnace shall be connected into a permanently live electric circuit. It is recommended that furnace be provided with a separate "circuit protection device" electric circuit. The furnace must be electrically grounded in accordance with local codes or in the absence of local codes with the National Electrical Code, ANSI/NFPA 70 or CSA C22.1 Electrical Code, if an external electrical source is utilized.

The integrated furnace control is polarity sensitive.

The hot leg of the 120V power supply must be connected to the black power lead as indicated on the wiring diagram. Provision for hooking up an electronic air cleaner and or humidifier is provided on the integrated control.

Refer to the SERVICE FACTS literature and unit wiring diagram attached to furnace.

Installer's Guide

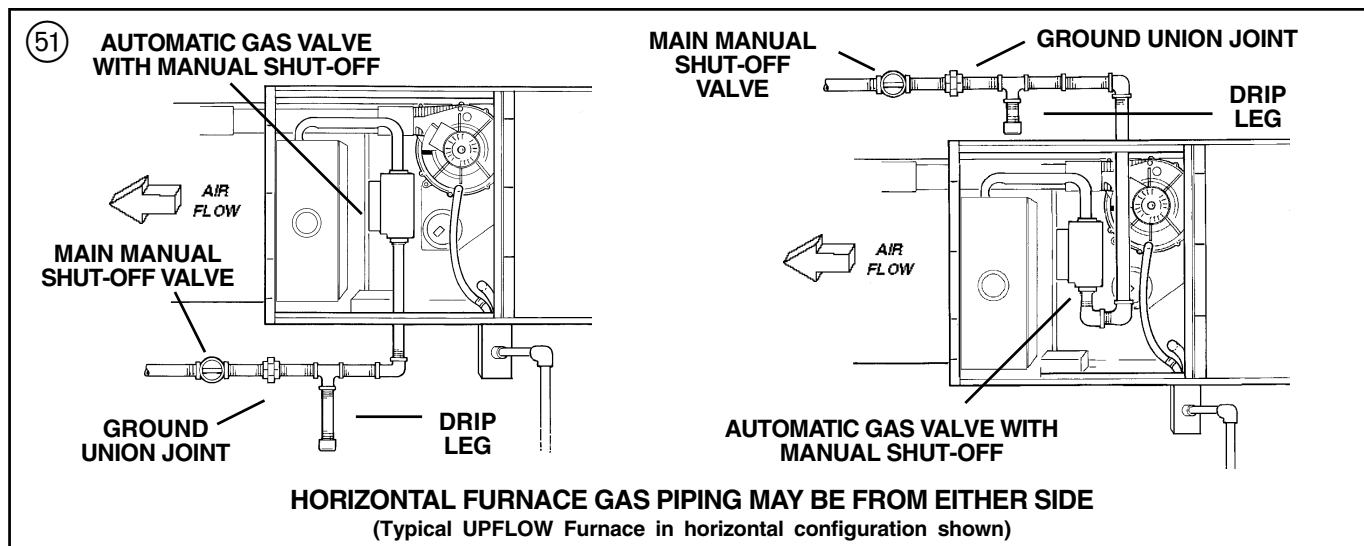
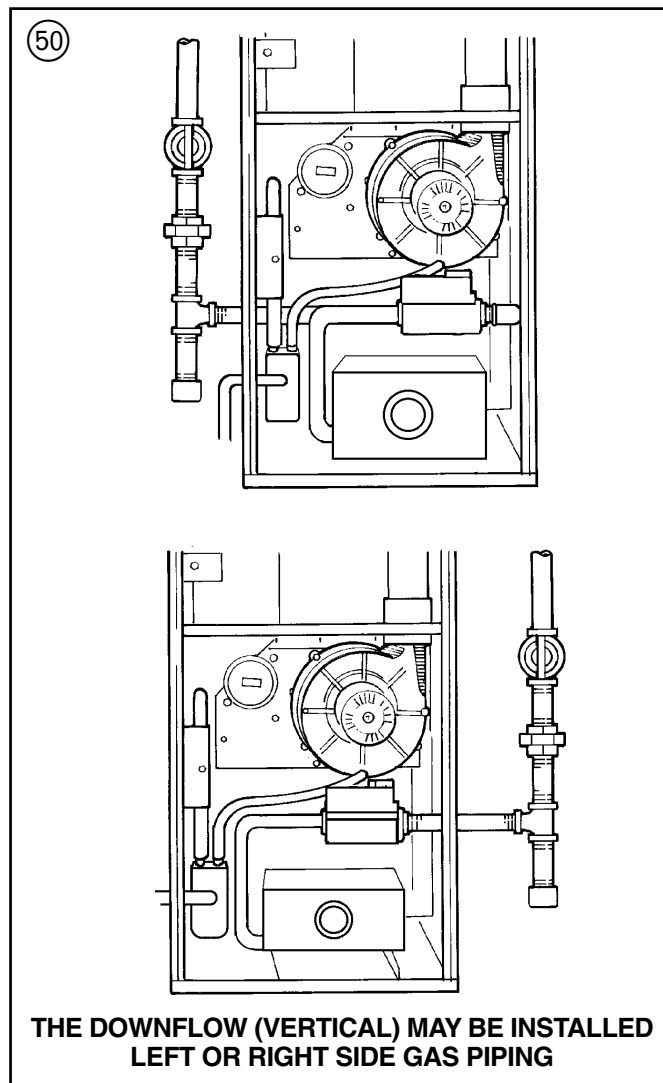
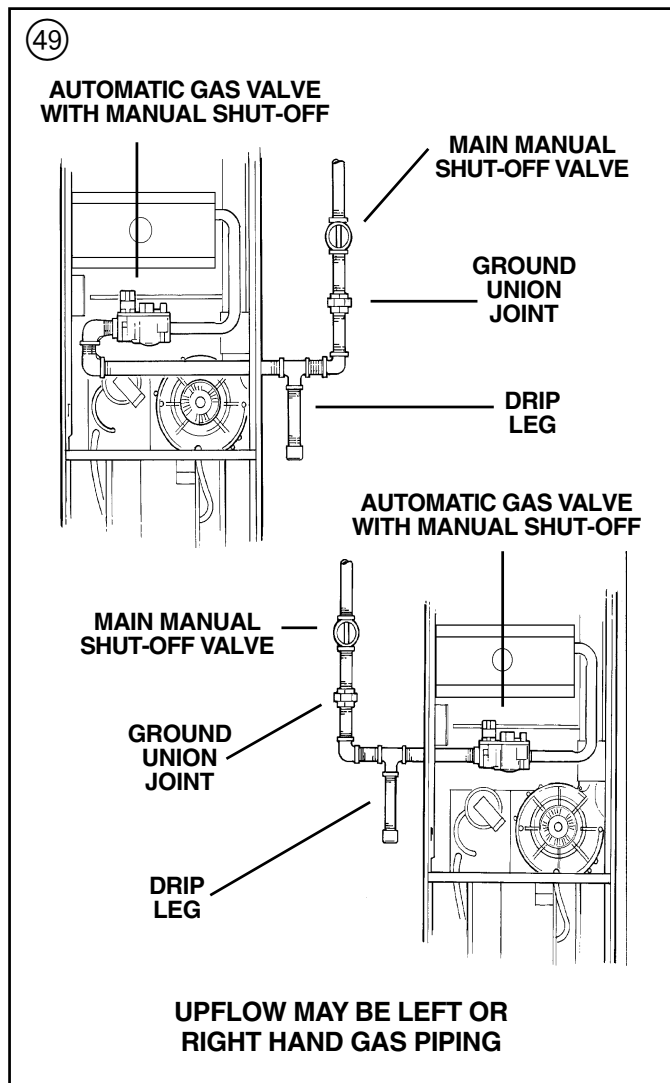

GAS PIPING

The upflow/horizontal furnace is shipped standard for left side installation of gas piping. A knockout is provided on the right side for an alternate gas piping arrangement. See Figure 49.

The installation of piping shall be in accordance with piping codes and the regulations of the local gas company. Pipe joint compound must be resistant to the chemical reaction with liquefied petroleum gases.

Refer to piping Table 13, for delivery sizes. Connect gas supply to the unit, using a ground joint union and a manual shut-off valve as shown in Figures 49 & 50. National codes require a condensation drip leg to be installed ahead of the controls as shown in Figures 49-51.

⚠ CAUTION

Use a backup wrench on the gas valve when installing gas piping to prevent damage to the gas valve and manifold assembly.

The furnace and its individual shut-off valve must be disconnected from the gas supply piping system during any pressure testing of that system at test pressures in excess of 1/2 psig (3.5 kPa).

The furnace must be isolated from the gas supply piping by closing its individual manual shut-off valve during any pressure testing of the gas supply piping system at test pressures equal to or less than 1/2 psig (3.5 kPa).

NOTE:

Maximum pressure to the gas valve for natural gas is 13.8" W.C. Minimum pressure is 5.0" W.C. Maximum pressure to the gas valve for propane is 13.8" W.C. Minimum pressure is 11.0" W.C.

All gas fittings must be checked for leaks using a soapy solution before lighting the furnace. **DO NOT CHECK WITH AN OPEN FLAME!**

TABLE 13 NATURAL GAS ONLY

TABLE OF CUBIC FEET PER HOUR OF GAS FOR VARIOUS PIPE SIZES AND LENGTHS							
PIPE SIZE	LENGTH OF PIPE						
	10	20	30	40	50	60	70
1/2	132	92	73	63	56	50	46
3/4	278	190	152	130	115	105	96
1	520	350	285	245	215	195	180
1-1/4	1050	730	590	520	440	400	370

This table is based on pressure drop of 0.3 inch W.C. and 0.6 SP.GR. gas

TABLE 14 ORIFICE SIZES

INPUT RATING BTUH	NUMBER OF BURNERS	MAIN BURNER ORIFICE DRILL SIZE	
		NAT. GAS	LP GAS
60,000	3	45	56
80,000	4	45	56
100,000	5	45	56
120,000	6	45	56

COMBUSTION AND INPUT CHECK

(See also High Altitude Derate)

1. Make sure all gas appliances are off except the furnace.
2. Clock the gas meter with the furnace operating (determine the dial rating of the meter) for one revolution.
3. Match the "Sec" column in the gas flow (in cfh) Table 15 with the time clocked.
4. Read the "Flow" column opposite the number of seconds clocked.
5. Use the following factors if necessary:
 For 1 Cu. Ft. Dial Gas Flow CFH =
 Chart Flow Reading ÷ 2
 For 1/2 Cu Ft. Dial Gas Flow CFH =
 Chart Flow Reading ÷ 4
 For 5 Cu. Ft. Dial Gas Flow CFH =
 10X Chart Flow Reading ÷ 4

52

CORRECT METHOD OF CHECKING DIRECT VENT MANIFOLD PRESSURE WITH BURNER BOX REFERENCED

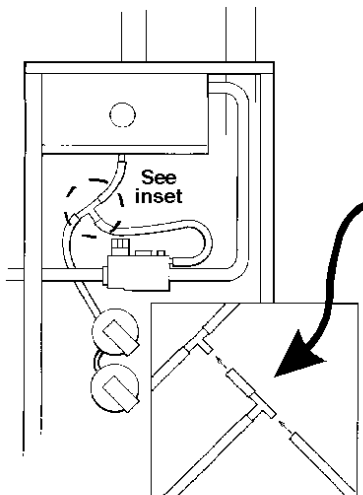

Separate the tube at the unit Tee and reconnect with a short piece of field supplied tube and another Tee with the "U" Manometer attached. Be sure to reconnect unit tubing to original position after testing the manifold pressure!

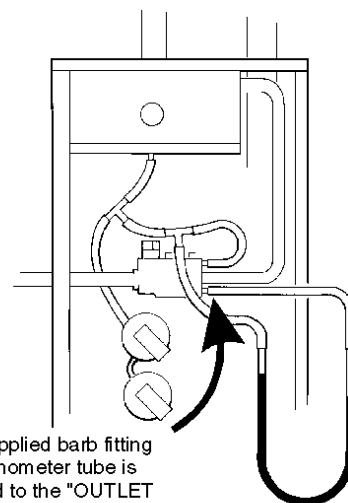

Field supplied barb fitting with manometer tube is attached to the "OUTLET PRESSURE TAP" on the outlet side of the gas valve.

⚠ CAUTION: Return all tubing, caps, and/or plugs to original positions when pressure checks are completed.

Installer's Guide

- Multiply the final figure by the heating value of the gas obtained from the utility company and compare to the nameplate rating. This must not exceed the nameplate rating.

⚠ WARNING

**HAZARD OF EXPLOSION
REPLACE AND/ OR TIGHTEN ALL PLUGS REMOVED OR
LOOSENED WHEN ADJUSTING GAS PRESSURE. LEAK
CHECK THE FITTINGS BEFORE PLACING THE FURNACE
INTO REGULAR SERVICE.
FAILURE TO FOLLOW THIS WARNING COULD RESULT IN
FIRE, EXPLOSION, PROPERTY DAMAGE, OR DEATH.**

Gas Valve Adjustment

Changes can be made by adjusting the manifold pressure (See Table 16), or changing orifices (orifice change may not always be required). To adjust the manifold pressure:

- Turn off all electrical power to the system.
 - Attach a manifold pressure gauge with flexible tubing to the outlet pressure boss marked "OUT P" on White-Rodgers gas valve model 36G or 36J. See Figure 53 for White-Rodgers gas valve model 36J. See Figure 54 for White-Rodgers gas valve model 36G.
 - Loosen (Do Not remove) the pressure tap test set screw one turn with 3/32" hex wrench.
 - The pressure tap adjustment kit (KIT07611) contains a 3/32" hex wrench, a 5/16" hose and a connector and can be ordered through Global Parts.
 - Turn on system power and energize valve.
- Adjust 1st stage gas heat by removing the low (LO) adjustment regulator cover screw.
 - To increase outlet pressure, turn the regulator adjust screw clockwise.
 - To decrease outlet pressure, turn the regulator adjust screw counterclockwise.
 - Adjust regulator until pressure shown on manometer matches the pressure specified in Table 16.
 - The input of no more than nameplate rating and no less than 93% of the nameplate rating, unless the unit is derated for high altitude.
 - Replace and tighten the regulator cover screw securely.
 - Adjust 2nd stage gas heat by removing the high (HI) adjustment regulator cover screw.
 - To increase outlet pressure, turn the regulator adjust screw clockwise.
 - To decrease outlet pressure, turn the regulator adjust screw counterclockwise.
 - Adjust regulator until pressure shown on manometer matches the pressure specified in Table 16.
 - The input of no more than nameplate rating and no less than 93% of the nameplate rating, unless the unit is derated for high altitude.
 - Replace and tighten the regulator cover screw securely.
 - Cycle the valve several times to verify regulator setting.
 - Repeat steps 5-7 if needed.
 - Turn off all electrical power to the system.
 - Remove the manometer and flexible tubing and tighten the pressure tap screw.
 - Using a leak detection solution or soap suds, check for leaks at the pressure outlet boss and pressure tap test screw.
 - Turn on system power and check operation of the unit.

TABLE 15

GAS FLOW IN CUBIC FEET PER HOUR							
2 CUBIC FOOT DIAL							
SEC.	FLOW	SEC.	FLOW	SEC.	FLOW	SEC.	FLOW
8	900	29	248	50	144	82	88
9	800	30	240	51	141	84	86
10	720	31	232	52	138	86	84
11	655	32	225	53	136	88	82
12	600	33	218	54	133	90	80
13	555	34	212	55	131	92	78
14	514	35	206	56	129	94	76
15	480	36	200	57	126	96	75
16	450	37	195	58	124	98	73
17	424	38	189	59	122	100	72
18	400	39	185	60	120	104	69
19	379	40	180	62	116	108	67
20	360	41	176	64	112	112	64
21	343	42	172	66	109	116	62
22	327	43	167	68	106	120	60
23	313	44	164	70	103	124	58
24	300	45	160	72	100	128	56
25	288	46	157	74	97	132	54
26	277	47	153	76	95	136	53
27	267	48	150	78	92	140	51
28	257	49	147	80	90	144	50

TABLE 16

FINAL MANIFOLD PRESSURE SETTINGS (inches w.c.)		
FUEL	2nd Stage Max.	1st Stage Max.
NATURAL GAS	3.5" W.C.	1.7" W.C.
LP GAS	10.5" W.C.	6.0" W.C.

TABLE 17
PART NUMBERS FOR REPLACEMENT ORIFICES

DRILL SIZE	PART NUMBER	DRILL SIZE	PART NUMBER
44	ORF00501	54	ORF00555
45	ORF00644	55	ORF00693
46	ORF00909	56	ORF00907
47	ORF00910	57	ORF00908
48	ORF01099	58	ORF01338
49	ORF00503	59	ORF01339
50	ORF00493		

NOTE:

The manifold pressure must be referenced to the burner box. The burner box pressure tap equalizes the gas valve pressure regulator. Manifold pressure is checked by installing a tee (field supplied) in the tubing, between the tee coming from the burner box tube and the gas valve, in addition to the regular gas valve pressure tap on the outlet side of the gas valve. See Figure 52.

TABLE 18

Orifice Twist Drill Size If Installed At Sea Level	ALTITUDE ABOVE SEA LEVEL and Orifice Required At Other Elevations									
	2000	3000	4000	5000	6000	7000	8000	9000	10000	
42	42	43	43	43	44	44	45	46	47	
43	44	44	44	45	45	46	47	47	48	
44	45	45	45	46	47	47	48	48	50	
45	46	47	47	47	48	48	49	49	50	
46	47	47	47	48	48	49	49	50	51	
47	48	48	49	49	49	50	50	51	52	
54	54	55	55	55	55	55	56	56	56	
55	55	55	55	56	56	56	56	56	57	
56	56	56	57	57	57	58	59	59	60	
57	58	59	59	60	60	61	62	63	63	
58	59	60	60	61	62	62	63	63	64	

From National Fuel Gas Code - Table F-4

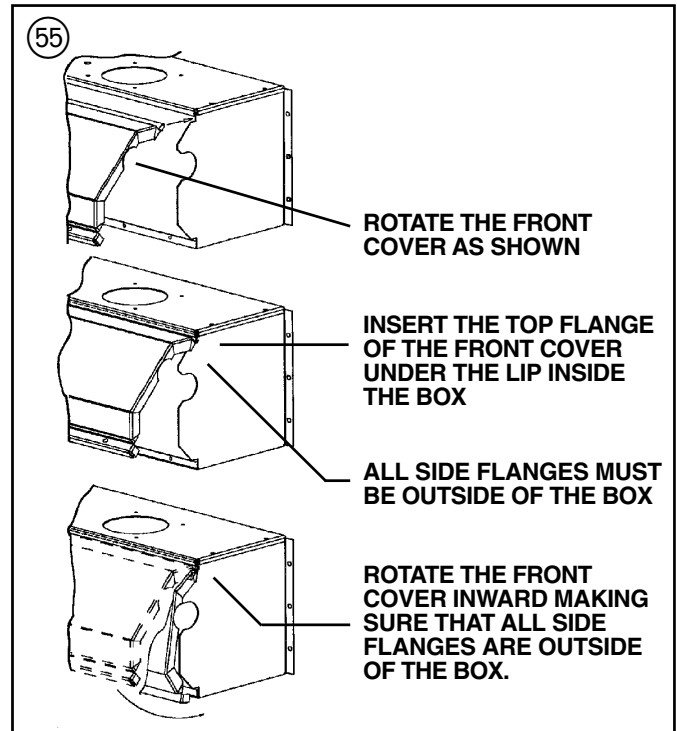

See Table 18 for help in selecting orifices if orifice change is required. Furnace input rate and temperature rise should be checked again after changing orifices to confirm the proper rate for the altitude.

The vent length table on page 16 shows the required vent lengths for installations at various altitudes. An optional high altitude kit is available for installations above 5000 feet. Installations above 12,000 feet are not allowed).

HIGH ALTITUDE DERATE

Input ratings (BTUH) of these furnaces are based on sea level operation and should not be changed at elevations up to 2,000 ft.

If the installation is 2,000 ft. or above, the furnace input rate (BTUH) shall be reduced 4% for each 1,000 ft. above sea level.

The furnace input rate shall be checked by clocking the gas flow rate (CFH) and multiplying by the heating value obtained from the local utility supplier for the gas being delivered at the installed altitude. Input rate changes can be made by adjusting the manifold pressure (min 3.0 - max 3.7 in. W.C. - Natural Gas) or changing orifices (orifice change may not always be required).

If the desired input rate cannot be achieved with a change in manifold pressure, then the orifices must be changed. LP installations will require an orifice change.

IMPORTANT:

Reinstall the propane orifices to the same depth as the orifices supplied with the equipment.

Installation of this furnace at altitudes above 2,000 ft. (610m) shall be in accordance with the local codes, or in the absence of local codes, the *National Fuel Gas Code, ANSI Z223.1/ NFPA 54* or *National Standard of Canada, Natural Gas and Propane Installation Code, CSA 149.1*. Installation of this furnace at altitudes above 2,000 ft. (610m) shall be made in accordance with the listed high Altitude Conversion Kit available with this furnace.

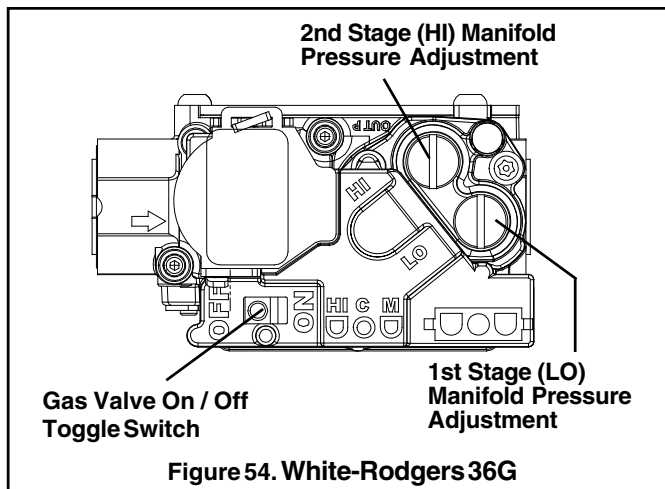
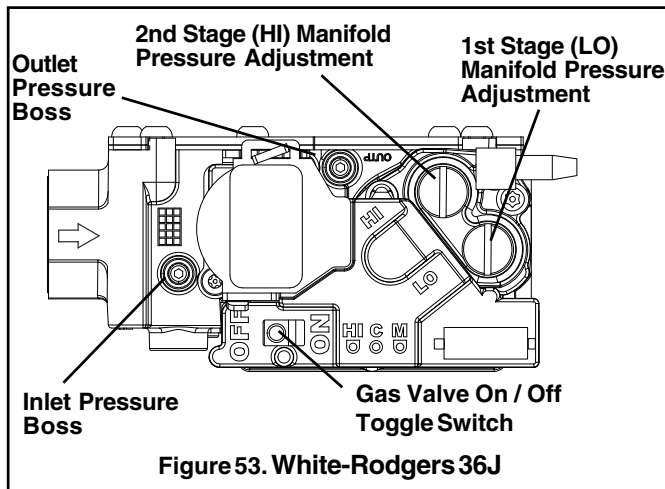

Installer's Guide

WARNING

EXPLOSION HAZARD!
PROPANE GAS IS HEAVIER THAN AIR AND MAY COLLECT IN ANY LOW AREAS OR CONFINED SPACES. IN ADDITION, ODORANT FADE MAY MAKE THE GAS UNDETECTABLE EXCEPT WITH A WARNING DEVICE. IF THE GAS FURNACE IS INSTALLED IN A BASEMENT, AN EXCAVATED AREA OR A CONFINED SPACE, IT IS STRONGLY RECOMMENDED TO CONTACT A GAS SUPPLIER TO INSTALL A GAS DETECTING WARNING DEVICE IN CASE OF A GAS LEAK.

NOTE: The manufacturer of your furnace does NOT test any detectors and makes no representations regarding any brand or type of detector.

CAUTION

Replace and/or tighten all plugs removed or loosened when adjusting gas pressure. Leak check the fittings before placing the furnace into regular service. Failure to follow this warning could result in fire, explosion, or property damage.

Table 17 lists the main burner orifices used with the furnace. If a change of orifices is required to correct the furnace input rating refer to Table 18.

REINSTALLATION OF THE BURNER BOX COVER

Figure 55 shows the correct way to reinstall the burner box cover if adjustment or replacement of the flame sensor, hot surface igniter, or main burner orifices have required removal of the cover.

START-UP AND ADJUSTMENT

PRELIMINARY INSPECTIONS

WARNING

ELECTRICAL SHOCK HAZARD
Disconnect power to the unit before removing the blower door. Allow a minimum of 10 seconds for IFC power supply to drain to 0 volts. Failure to follow this warning could result in property damage, personal injury or death.

With gas and electrical power "OFF"

1. Duct connections are properly sealed
2. Filters are in place
3. Venting is properly assembled
4. Blower door is in place

Turn the main gas valve toggle switch (See Figures 53 & 54) within the unit to the "OFF" position. Turn the external gas valve to "ON". Purge the air from the gas lines. After purging, check all gas connections for leaks with a soapy solution — **DO NOT CHECK WITH AN OPEN FLAME**. Allow 5 minutes for any gas that might have escaped to dissipate.

LP Gas being heavier than air may require forced ventilation. Turn the toggle switch on the gas valve in the unit to the "ON" position.

LIGHTING INSTRUCTIONS

WARNING

SAFETY HAZARD
DO NOT attempt to manually light the burner. Failure to follow this warning could result in property damage, personal injury or death.

Lighting instructions appear on each unit. Each installation must be checked out at the time of initial start up to insure proper operation of all components. Check out should include putting the unit through one complete cycle as outlined below.

Turn on the main electrical supply and set the thermostat above the indicated temperature. The ignitor will automatically heat, then the gas valve is energized to permit the flow of gas to the burners. After ignition and flame is established, the flame control module monitors the flame and supplies power to the gas valve until the thermostat is satisfied.

To shut off

For complete shutdown: Turn the gas cock knob on the main gas valve to the "OFF" position (See Figure 49). Disconnect the electrical supply to the unit.

CAUTION

If this is done during the cold weather months, provisions must be taken to prevent freeze-up of all water pipes and water receptacles.

Whenever your house is to be vacant, arrange to have someone inspect your house for proper temperature. This is very important during freezing weather. If for any reason your furnace should fail to operate damage could result, such as frozen water pipes.

SEQUENCE OF OPERATION

Thermostat call for heat (2-stage thermostat)

Call for 1st stage only:

W1 thermostat contacts close signaling the control module to run its self-check routine. After the control module has verified that the 1st stage pressure switch contacts are open and the limit switch(es) contacts are closed, the draft blower will be energized.

As the induced draft blower comes up to speed, the pressure switch contacts will close and the ignitor warm up period will begin. The ignitor will heat for approx. 20 seconds, then the gas valve is energized in 1st stage to permit gas flow to the burners.

The flame sensor confirms that ignition has been achieved within the 4 second ignition trial period.

As the flame sensor confirms that ignition has been achieved, the delay to fan ON period begins timing and after approx. 45 seconds the indoor blower motor will be energized at low speed and will continue to run during the heating cycle.

Call for 2nd stage after 1st stage:

W2 thermostat contacts close signaling a call for 2nd stage heat. After a 30 second delay, the induced draft blower will be energized on high speed and the 2nd stage pressure switch contacts will close. The gas valve is energized in 2nd stage and the indoor blower motor in high speed.

2nd stage satisfied, 1st stage still called:

W2 thermostat contacts open signaling that 2nd stage heating requirements are satisfied.

The induced draft blower is reduced to low speed allowing the 2nd stage pressure switch contacts to open and the gas valve is reduced to 1st stage. The indoor blower motor is reduced to low speed.

1st stage satisfied:

W1 thermostat contacts open signaling that 1st stage heating requirements are satisfied. The gas valve will close and the induced draft blower will be de-energized. The indoor blower motor will continue to run for the fan off period (Field selectable at 60, 100, 140 or 180 seconds), then will be de-energized by the control module.

Thermostat call for heat (1-stage Thermostat)

W1/W2 (jumpered) thermostat contacts close signaling a call for heat. 1st stage sequence of operation remains the same as above. 2nd stage heat will energize after the stage delay timer (field selectable at .5, 5, 10 or 15 minutes) has expired.

Thermostat satisfied:

W1/W2 (jumpered) contacts open signaling the control module to close the gas valve. The induced draft blower is switched to low speed and de-energized after the post purge timer has expired. The indoor blower motor will continue to operate after the flames are extinguished and then is switched to low heat speed for the FAN-OFF period.

CONTROL AND SAFETY SWITCH ADJUSTMENTS

LIMIT SWITCH CHECK OUT

The limit switch is a safety device designed to close the gas valve should the furnace become overheated. Since proper operation of this switch is important to the safety of the unit, it **must be checked out on initial start up by the installer.**

To check for proper operation of the limit switches, set the thermostat to a temperature higher than the indicated temperature to bring on the gas valve. Restrict the airflow by blocking the return air (disconnecting the indoor blower may trip the inducer limit). When the furnace reaches the maximum outlet temperature as shown on the rating plate, the burners must shut off. If they do not shut off after a reasonable time and overheating is evident, a faulty limit switch is probable and the limit switch must be replaced. After checking the operation of the limit control, be sure to remove the paper or cardboard from the return air inlet. Refer to Service Facts for additional instructions.

NOTE TO INSTALLER

Review the following warnings with the owner. Review contents of USER'S INFORMATION MANUAL with the owner.

AIRFLOW ADJUSTMENT

Check inlet and outlet air temperatures to make sure they are within the ranges specified on the furnace rating nameplate. If the airflow needs to be increased or decreased, see the wiring diagram for information on changing the speed of the blower motor.

WARNING

ELECTRICAL SHOCK HAZARD

Disconnect power to the unit before removing the blower door. Allow a minimum of 10 seconds for IFC power supply to drain to 0 volts. Failure to follow this warning could result in property damage, personal injury or death.

This unit is equipped with a blower door switch which cuts power to the blower and gas valve causing shutdown when the door is removed. Operation with the door removed or ajar can permit the escape of dangerous fumes. All panels must be securely closed at all times for safe operation of the furnace.

INDOOR BLOWER TIMING

Heating: The integrated furnace control module controls the indoor blower. The blower start is fixed at 45 seconds after ignition. The FAN-OFF period is field selectable by dip switches SW-2, #1 and #2 at 60, 100, 140, or 180 seconds. The factory setting is 100 seconds.

W1-W2 stage delay (jumpered together) is field selectable by dip switch SW-1, #1 and #2 at .5, 5, 10 or 15 minutes. The factory setting is 10 minutes. (See wiring diagram).

Cooling: The fan delay off period is factory set at 0 seconds. The option for 80 second delay off is field selectable by dip switch SW-2, #3 (See wiring diagram).

ROOM AIR THERMOSTAT

HEAT ANTICIPATOR ADJUSTMENT

Set the thermostat heat anticipator according to the current flow measured, or the settings found in the notes on the furnace wiring diagram (found in the SERVICE FACTS or inside the furnace casing).

INSTRUCTIONS TO THE OWNERS

WARNING

EXPLOSION HAZARD

In the event that electrical, fuel, or mechanical failures occur, shut off the gas supply off at the manual gas valve, located on the supply gas piping coming into the furnace, before turning off the electrical power to the furnace. Contact the service agency designated by your dealer.

BURNER BOX TEMPERATURE LIMIT DEVICE

All models are equipped with a manual reset temperature limit located on the burner box. In case of excessive temperature, the limit will open and cause the circuit to open which shuts off all flow of gas.

Installer's Guide

ABNORMAL CONDITIONS

1. EXCESSIVE COMBUSTION PRESSURE (WIND IN EXCESS OF 40 M.P.H.) VENT OR FLUE BLOCKAGE

On a call for heat, the variable speed draft inducer must first ramp up to speed and close the pressure switch before the ignition sequence is allowed to begin. If the pressure switch does not close, the motor will ramp up to maximum speed and continue to operate there for about 1 minute.

After one minute the integrated furnace control will turn the motor off for about 30 seconds then back on in an attempt to reestablish proper operation. This condition is indicative of a highly restricted or blocked inlet or outlet vent pipe or a failed pressure switch.

If pressure against induced draft blower outlet becomes excessive, the pressure switch will open. If the pressure switch is open for more than 3.5 seconds, the variable speed draft inducer will speed up and attempt to close the pressure switch. If the pressure switch is not closed within 12 seconds or if the maximum speed of the motor is reached, the draft inducer sends a fault signal to the integrated furnace control. If the unit is operating in second stage, an inducer fault will cause the furnace control to transition the system to first stage and it will operate there for 10 minutes before attempting to run again in second stage. If the unit is operating in first stage, an inducer fault will cause the furnace control to shut the system down and wait 30 seconds before attempting to reestablish operation in first stage.

2. LOSS OF FLAME

If loss of flame occurs during a heating cycle, or flame is not present at the sensor, the flame control module will close the gas valve. The flame control module will then recycle the ignition sequence, then if ignition is not achieved, it will shut off the gas valve and lock out the system.

3. POWER FAILURE

If there is a power failure during a heating cycle, the system will restart the ignition sequence automatically when power is restored, if the thermostat still calls for heat.

4. GAS SUPPLY FAILURE

If loss of flame occurs during a heating cycle, the system integrated control module will recycle the ignition sequence, then if ignition is not achieved, the integrated control module will shut off the gas valve and lock out the system.

5. INDUCED DRAFT BLOWER FAILURE

Please refer to the variable speed draft inducer troubleshooting manual for diagnostic assistance.

6. CONDENSATE DRAIN BLOCKAGE

If the condensate drain is blocked, either by debris, improper draining, or by freezing condensate, the pressure switch will receive a signal warning of the accumulation of condensate in the heat exchanger assembly. The pressure switch contacts will open and remain open, not allowing unit operation. The unit will not operate until the condensate drain has been cleared, and the condensate flows freely.

7. RESET AFTER LOCKOUT

When the integrated control module has shut the system down and gone into lockout, the system must be manually reset before the unit will restart. The system can be reset by turning the system power off for more than 1 second, or by removing 24VAC from the control for more than 1 second, or by removing the thermostat call for heat for more than 1 second but less than 20 seconds.

8. RESET AFTER BURNER BOX LIMIT SHUTDOWN

If the furnace shuts down, one thing that can be checked is the burner box temperature limit switch. It is located on the bottom of the burner box. The vent and combustion air inlet terminations should be checked for blockage. If blockage exists, clear the problem and then the reset button may be depressed. **If there is no blockage of the terminations, the limit switch must be reset by a qualified servicer.**

FAULT CODE RECOVERY

On power up, last 4 faults, if any, will be flashed on the red LED. The newest fault detected will flash first and the oldest last. There will be a 2 second delay between fault code flashes. Solid red LED error codes will not be displayed.

The Green LED will be on solid during last fault recovery. At any other time the control is powered, the Green LED indicator light will operate as shown in Table 19 and the red LED will flash LitePort data (one flash) every 20 seconds.

Fault Code Reset

The last 4 fault codes can be erased from memory by powering up the control with "G" energized and then applying "R" to the "W1" terminal 3 times within 6 seconds. The control will acknowledge the reset by turning on the red LED for 2 seconds.

TABLE 19

INTEGRATED FURNACE CONTROL GREEN "STATUS" LED FLASH CODES	
Flashing Slow ---	Normal - No call for Heat
Flashing Fast ---	Normal - Call for Heat

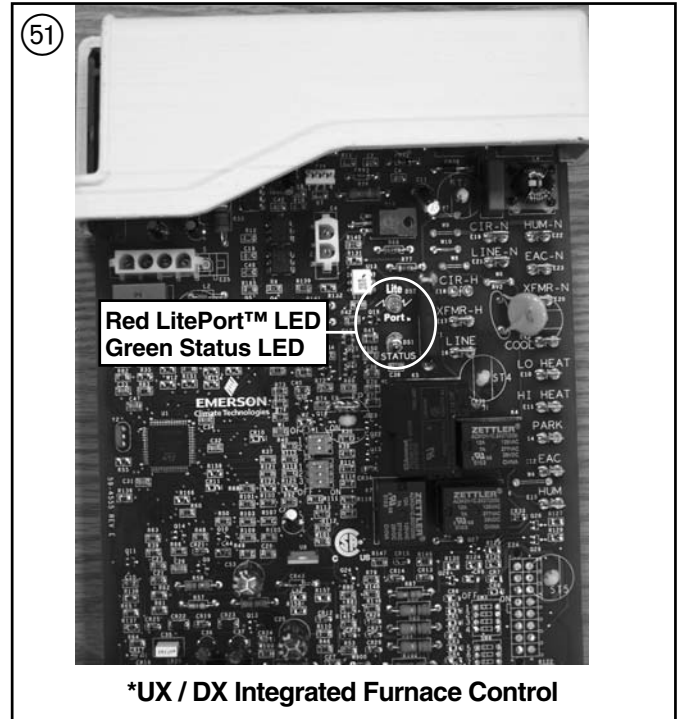

*UX / DX Integrated Furnace Control

INTEGRATED FURNACE CONTROL RED LED "ERROR" FLASH CODES	
2 Flashes ---	System Lockout (Retries or Recycles exceeded)
3 Flashes ---	Draft Pressure Error - Possible problems: a) Venting problem b) Pressure switch problem c) Inducer problem
4 Flashes ---	Open Temperature Limit Switch
5 Flashes ---	Flame sensed when no flame should be present
6 Flashes ---	115 volt AC power reversed, ignitor (Triac) fault, poor grounding or system voltage too low
7 Flashes ---	Gas valve circuit error
8 Flashes ---	Low flame sense
9 Flashes ---	Open Inducer Limit switch
10 Flashes ---	Inducer communication error
Solid ---	Internal GV error or Low TH voltage
Solid Red w/Solid Green "STATUS" LED	Continuous Reset caused by a blown fuse or internal error.



Literature Order Number	18-CD18D8-20
File Number	18-CD18D8-20
Supersedes	18-CD18D8-19
Date	12/11

Trane
6200 Troup Highway
Tyler, TX 75707

*For more information contact
your local dealer (distributor)*

*Since the manufacturer has a policy of continuous product and product data improvement, it reserves the right to
change design and specifications without notice.*