



# Installer's Guide

## Heat Pumps

### 2TWZ9C with ComfortLink™ II and Charge Assist™

**ALL phases of this installation must comply with NATIONAL, STATE AND LOCAL CODES**

**IMPORTANT** — This Document is **customer property** and is to remain with this unit. Please return to service information pack upon completion of work.

**These instructions do not cover all variations in systems nor provide for every possible contingency to be met in connection with installation. All phases of this installation must comply with NATIONAL, STATE AND LOCAL CODES.** Should further information be desired or should particular problems arise which are not covered sufficiently for the purchaser's purposes, the matter should be referred to your installing dealer or local distributor.

#### A. GENERAL

#### **WARNING**

This information is intended for use by individuals possessing adequate backgrounds of electrical and mechanical experience. Any attempt to repair a central air conditioning product may result in personal injury and or property damage. The manufacturer or seller cannot be responsible for the interpretation of this information, nor can it assume any liability in connection with its use.

#### **NOTICE:**

*Trane has always recommended installing Trane approved matched indoor and outdoor systems.*

*The benefits of installing approved matched systems are maximum efficiency, optimum performance and best overall system reliability.*

Check for transportation damage after unit is uncrated. Report promptly, to the carrier, any damage found to the unit.

To determine the electrical power requirements of the unit, refer to the nameplate of the unit. The electrical power available must agree with that listed on the nameplate.

The Weathertron® Heat Pump has been designed and manufactured to withstand and operate in severe winter conditions. However, there are precautionary steps which should be taken at the time of installation which will help assure the efficient operation of the unit. **It is recommended that these precautions be taken for units being installed in areas where snow accumulation and prolonged below freezing temperatures occur.**

1. Units should be elevated three (3) to twelve (12) inches above the pad or rooftop, depending on local weather. This additional height will allow better drainage of snow and ice (melted during defrost cycle) prior to its refreezing. This should prevent a build-up of ice around the unit which occurs when unit is not elevated. **Insure that drain holes in unit base pan are not obstructed preventing draining of defrost water.**
2. If possible, avoid locations that are likely to accumulate snow drifts. If not possible, a snow drift barrier should be installed around the unit to prevent a build-up of snow on the sides of the unit and should be of sufficient distance from the unit to prevent restriction of airflow to and from the unit. Also allow for proper maintenance space. The barrier should be constructed of materials which will blend in with the building design.

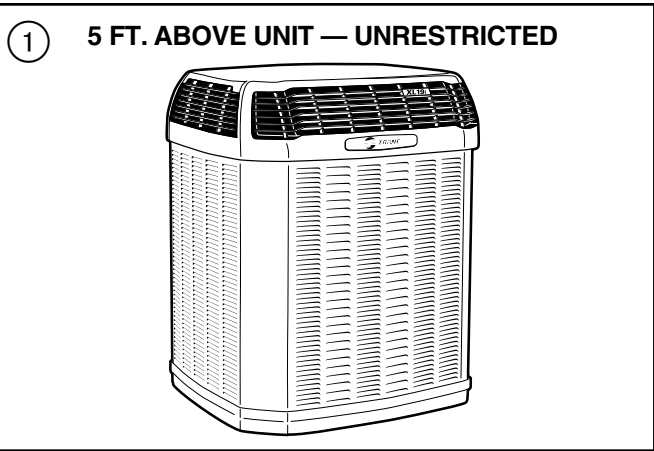

3. Avoid locating the unit where condensation and freezing of defrost vapor may annoy the customer. For instance, installing the unit under a bedroom, kitchen, or picture window may be annoying to the customer since condensate and fog will occur during the defrost cycle.
4. Avoid locating the unit under the eaves or other overhead structures as sizeable icicles may form and the unit may be damaged by these falling icicles.

#### **B. LOCATION AND PREPARATION OF THE UNIT**

1. When removing unit from the pallet, notice the tabs on the basepan. Remove tabs by cutting with a sharp tool as shown in Figure 2 (see page 2) and slide unit off of pallet.
2. The unit should be set on a level support pad at least as large as the unit base pan, such as a concrete slab. If this is not the application used please refer to application bulletin "Trane XR-APG\*\* -EN" (\* denotes latest revision number).
3. The support pad must NOT be in direct contact with any structure. Unit must be positioned a minimum of 12" from any wall or surrounding shrubbery to insure adequate airflow. Clearance must be provided in front of control box (access panels) and any other side requiring service access to meet National Electrical Code. Also, the unit location must be far enough away from any structure to prevent excess roof run-off water from pouring directly on the unit. Do not locate unit(s) close to bedroom(s).
4. The top discharge area must be unrestricted for at least five (5) feet above the unit.
5. When the outdoor unit is mounted on a roof, be sure the roof will support the unit's weight. Properly selected isolation is recommended to prevent transmission to the building structure.
6. The maximum length of refrigerant lines from outdoor to indoor unit should NOT exceed sixty (60) feet.

# Installer's Guide

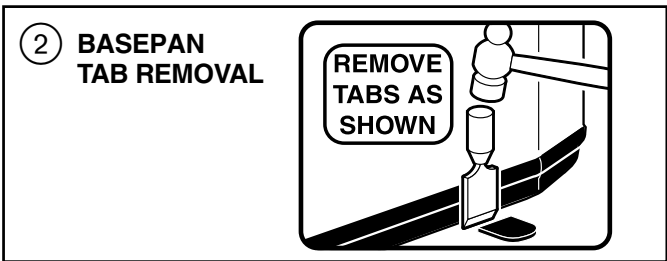

- If outdoor unit is mounted above the air handler, maximum lift should not exceed twenty-five (25) feet (suction line). If air handler is mounted above condensing unit, maximum lift should not exceed twenty-five (25) feet (liquid line).
- Locate and install indoor coil or air handler in accordance with instruction included with that unit.

## C. INSTALLING REFRIGERANT LINES

### ⚠ CAUTION

If using existing refrigerant lines make certain that all joints are brazed, not soldered.

Condensing units have provisions for braze connections. Pressure taps are provided on the service valves of outdoor unit for compressor suction and liquid pressures. The indoor end of the recommended refrigerant line sets may be straight or with a ninety (90) degree bend, depending upon situation requirements. This should be thoroughly checked out before ordering refrigerant line sets. The gas line must always be insulated.

### ⚠ CAUTION

In scroll compressor applications, dome temperatures may be hot. Do not touch top of compressor, may cause minor to severe burning.

The units are factory charged with the system charge required when using fifteen (15) feet of rated connecting line. Unit nameplate charge is with twenty-five (25) feet of line set.

**Final refrigerant charge adjustment is necessary.** Use the Subcooling Charging procedure in the outdoor unit Service Facts.

- Determine the most practical way to run the lines.
- Consider types of bends to be made and space limitations.

**NOTE:** Large diameter tubing will be very difficult to rebend once it has been shaped.

- Determine the best starting point for routing the refrigerant tubing — INSIDE OR OUTSIDE THE STRUCTURE.
- Provide a pull-thru hole of sufficient size to allow both liquid and gas lines.
- Be sure the tubing is of sufficient length.
- Uncoil the tubing — do not kink or dent.
- Route the tubing making all required bends and properly secure the tubing before making connections.
- To prevent a noise within the building structure due to vibration transmission from the refrigerant lines, the following precautions should be taken:
  - When the refrigerant lines have to be fastened to floor joists or other framing in a structure, use isolation type hangers.
  - Isolation hangers should also be used when refrigerant lines are run in stud spaces or enclosed ceilings.
  - Where the refrigerant lines run through a wall or sill, they should be insulated and isolated.
  - Isolate the lines from all ductwork.

## D. SERVICE VALVE OPERATION

### BRASS LIQUID LINE SERVICE VALVE

The Brass Liquid Line Service Valve is factory shipped in the seated position to hold factory charge. The pressure tap service port (when depressed) opens only to the field brazing side of the valve when the valve is in the seated position. The liquid line valve is **not** a back seating valve (see **WARNING** below).

### ⚠ WARNING

Extreme caution should be exercised when opening the Liquid Line Service Valve. Turn valve stem counterclockwise only until the stem contacts the rolled edge. (See Figures 3 and 5). No torque is required. Failure to follow this warning will result in abrupt release of system charge and may result in personal injury and/or property damage.

### BRASS GAS LINE BALL SERVICE VALVE

The Brass Gas Line Service Valve is shipped in the closed position to hold the factory refrigerant charge. The pressure tap service port (when depressed) opens only to the field brazing side when the valve is in the closed position.

The Gas Line Ball Service Valve is full open with a 1/4 turn. See Figure 4.

### BRAZING REFRIGERANT LINES

- Remove lower access cover to access service valves.
- Before brazing, remove plugs from external copper stub tubes. Clean internal and external surfaces of stub tubes prior to brazing.
- Cut and fit tubing, minimizing the use of sharp 90° bends.
- Insulate the entire gas line and its fittings.
- Do **NOT** allow uninsulated liquid line to come in direct contact with bare gas line.
- Precautions should be taken to avoid heat damage to the pressure tap valve core during brazing. It is recommended that the pressure tap port valve core be removed and a wet rag wrapped around the valve body.

**NOTE:** Use care to make sure that no moisture enters pressure tap port, while wet rag is being used.

**NOTE:** Precautions should be taken to avoid heat damage to basepan during brazing. It is recommended to keep the flame directly off of the basepan.

- Use a Dry Nitrogen Purge and Brazing Alloy without flux when brazing the field line to the copper factory connection. Flow dry nitrogen into either valve pressure tap port, thru the tubing and out the other port while brazing.
- Braze using accepted good brazing techniques.

### LEAK CHECK

**IMPORTANT:** Replace pressure tap port valve core before attaching hoses for evacuation.

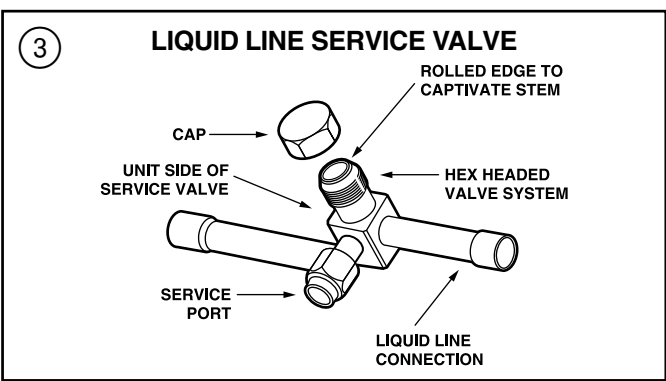

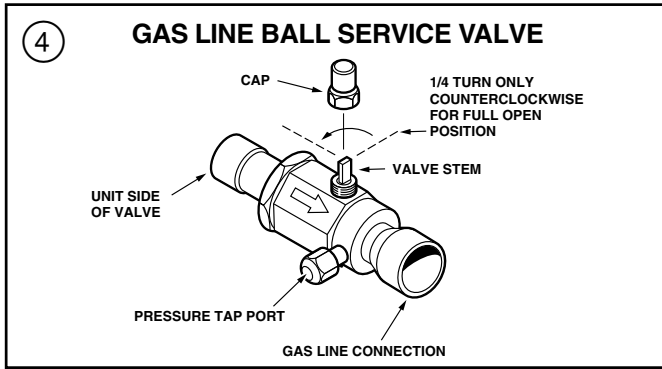

After the brazing operation of refrigerant lines to both the outdoor and indoor unit is completed, the field brazed connections must be checked for leaks. Pressurize through the service valve ports, the indoor unit and field refrigerant lines with dry nitrogen to 350-400 psi. Use soap bubbles or other leak-checking methods to see that all field joints are leak-free! If not, **release pressure**; then repair!

## SYSTEM EVACUATION

### NOTE:

*Since the outdoor unit has a refrigerant charge, the gas and liquid line valves must remain closed.*

1. Upon completion of leak check, evacuate the refrigerant lines and indoor coil before opening the gas and liquid line valves.
2. Attach appropriate hoses from manifold gauge to gas and liquid line pressure taps.

### NOTE:

*Unnecessary switching of hoses can be avoided and complete evacuation of all lines leading to sealed system can be accomplished with manifold center hose and connecting branch hose to a cylinder of HCFC-22 and vacuum pump.*

3. Attach center hose of manifold gauges to vacuum pump.
4. Evacuate until the micron gauge reads no higher than 350 microns.
5. Close off valve to vacuum pump and observe the micron gauge. If gauge pressure rises above 500 microns in one (1) minute, then evacuation is incomplete or system has a leak.
6. If vacuum gauge does not rise above 500 microns in one (1) minute, the evacuation should be complete.
7. Blank off vacuum pump and micron gauge, close valves on manifold gauge set.

### NOTE:

**DO NOT VENT REFRIGERANT INTO THE ATMOSPHERE.**

### NOTE:

**A 3/16" Allen wrench is required to open liquid line service valve. A 1/4" Open End or Adjustable wrench is required to open gas line valve. A 3/4" Open End wrench is required to take off the valve stem cap.**

8. The liquid line shut-off valve can now be opened. Remove shut-off valve cap. Fully insert hex wrench into the stem and backout counterclockwise until valve stem just touches rolled edge (approximately five [5] turns) observing **WARNING** statement on page 2. See Figure 3.
9. Replace liquid service pressure tap port cap and valve stem cap. These caps **MUST BE REPLACED** to prevent leaks. Replace valve stem and pressure tap cap finger tight, then tighten an additional 1/6 turn.
10. The gas valve can now be opened. For a ball type gas valve, open the gas valve by removing the shut-off valve cap and turning the valve stem 1/4 turn counterclockwise, using 1/4" Open End or Adjustable wrench. See Figure 4. For brass gas line service valve opening, follow 8 and 9 above. See Figure 5.
11. The gas valve is now open for refrigerant flow. Replace valve stem cap to prevent leaks. Again, these caps **MUST BE REPLACED** to prevent leaks. Replace valve stem and

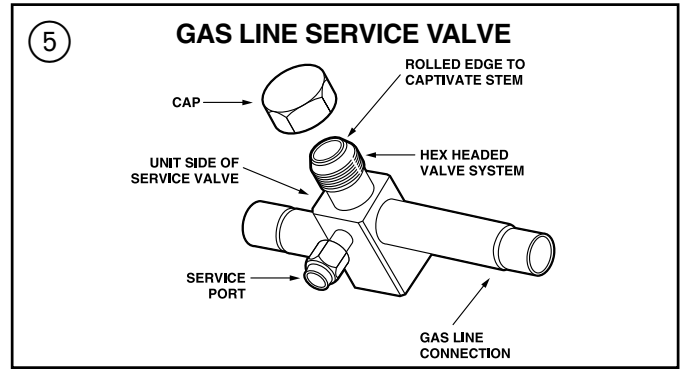

pressure tap cap finger tight, then tighten an additional 1/6 turn. See Figure 4.

If refrigerant lines are longer than fifteen (15) feet and/or a different size than recommended, it will be necessary to adjust system refrigerant charge upon completion of installation. See unit Service Facts.

## E. ELECTRICAL CONNECTIONS

### ⚠ WARNING

**When installing or servicing this equipment, ALWAYS exercise basic safety precautions to avoid the possibility of electric shock.**

1. Power wiring and grounding of equipment must comply with local codes.
2. Power supply must agree with equipment nameplate.
3. Install a separate disconnect switch at the outdoor unit.
4. Ground the outdoor unit per local code requirements.
5. Provide flexible electrical conduit whenever vibration transmission may create a noise problem within the structure.
6. The use of color coded low voltage wire is recommended to simplify connections between the outdoor unit, the ComfortLink™ II control and the indoor unit.

**Table 1 – NEC Class II Control Wiring**

ComfortLink™ II Control Wiring	
WIRE SIZE	MAX. WIRE LENGTH
18 AWG	250 FT

### NOTE:

**The maximum total cable length for the entire Comfort Control communicating system is 500 ft. 18 AWG.**

7. Mount the ComfortLink™ II control in accordance with instruction included with the ComfortLink™ II control. Wire per appropriate hook-up diagram (included in these instructions).

## F. DEFROST CONTROL

The demand defrost control measures heat pump outdoor ambient temperature with a sensor located outside the outdoor coil. A second sensor located on the outdoor coil is used to measure the coil temperature. The difference between the ambient and the colder coil temperature is the difference or delta-T measurement. This delta-T measurement is representative of the operating state and relative capacity of the heat pump system. By measuring the change in delta-T, we can determine the need for defrost. The coil sensor also serves to sense outdoor coil temperature for termination of the defrost cycle.

### FAULT IDENTIFICATION

A fault condition is indicated by the fault LED on the control board inside the heat pump control box.

In normal operation, the status LED will flash once each second. If the light is flashing more than once per second or not at all, refer to the service manual for that unit.

# Installer's Guide

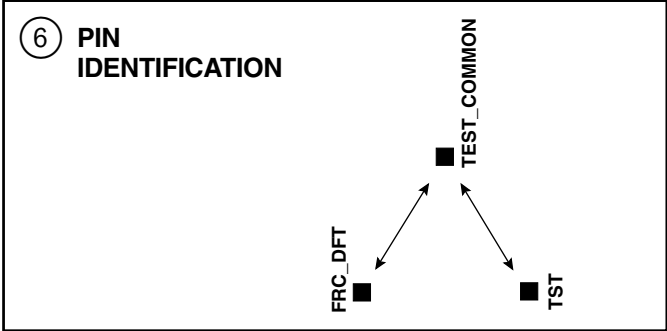

**PIN IDENTIFICATION (SEE FIGURE 6.)**

1. TEST\_COMMON (Shorting any of the other pins to this pin causes the function of the other pin to be executed. Leaving this pin open results in the normal mode of operation.)
2. TST = Test (Shorting TEST\_COMMON to this pin speeds up all defrost board timings.)
3. FRC\_DFT = Forced Defrost (Short TEST\_COMMON to this pin for two [2] seconds to initiate a forced defrost. Remove the short after defrost initiates.)

**DEFROST CONTROL CHECKOUT**

Normal operation requires:

- a. Status LED on board flashing 1 time/second.
- b. 12VDC between D & B.
- c. Defrost initiation when FRC\_DFT pin is shorted to TEST\_COMMON pin.

If a defrost control problem is suspected, refer to the service information in control box.

**G. COMPRESSOR START UP**

After all electrical wiring is complete, SET THE COMFORTLINK™ II CONTROL SWITCH IN THE OFF POSITION SO COMPRESSOR WILL NOT RUN, and apply power by closing the system main disconnect switch. This will activate the compressor sump heat (where used). Do not change the ComfortLink™ II control Switch until power has been applied for one (1) hour. Following this procedure will prevent potential compressor overload trip at the initial start-up.

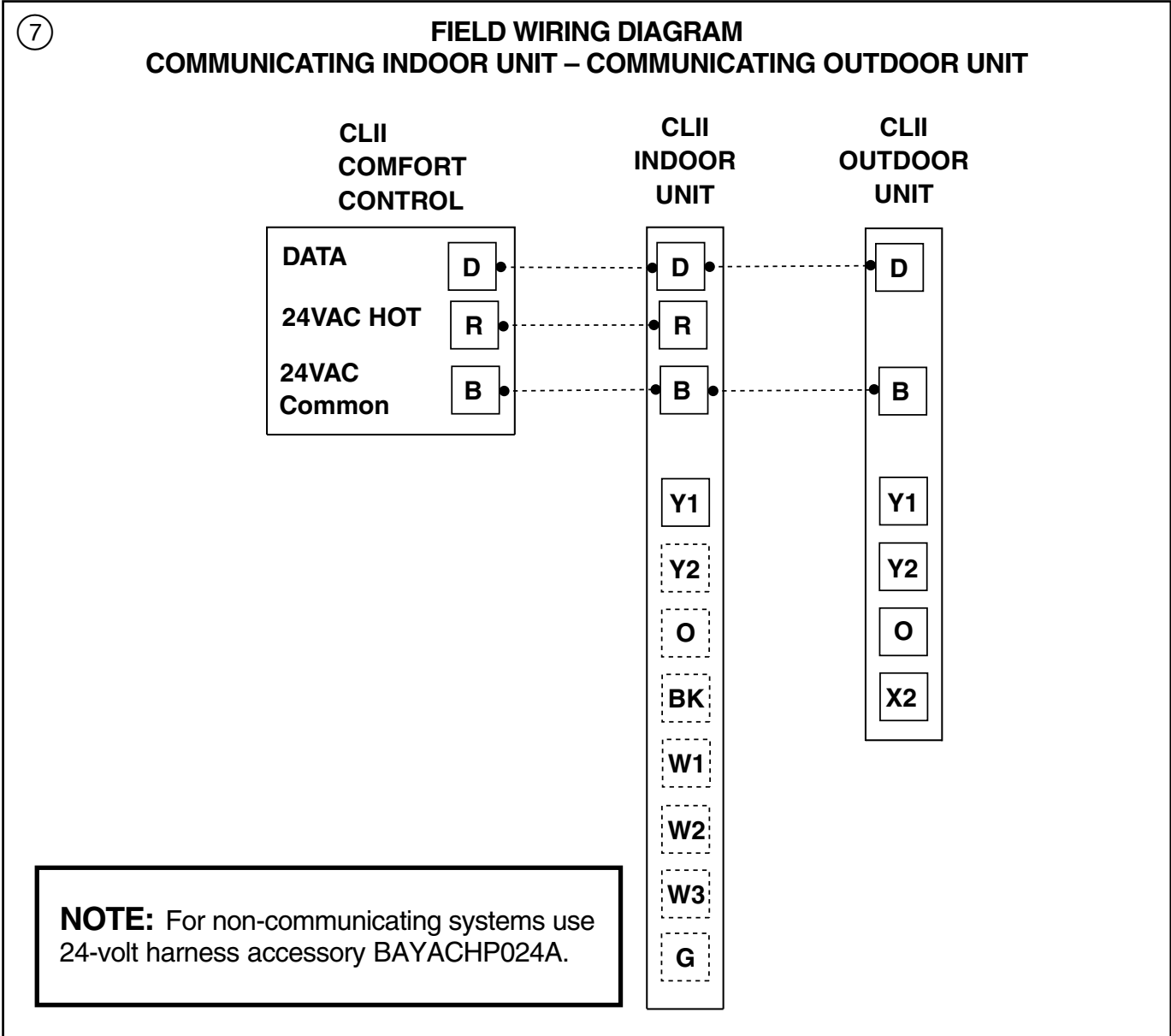



# Installer's Guide

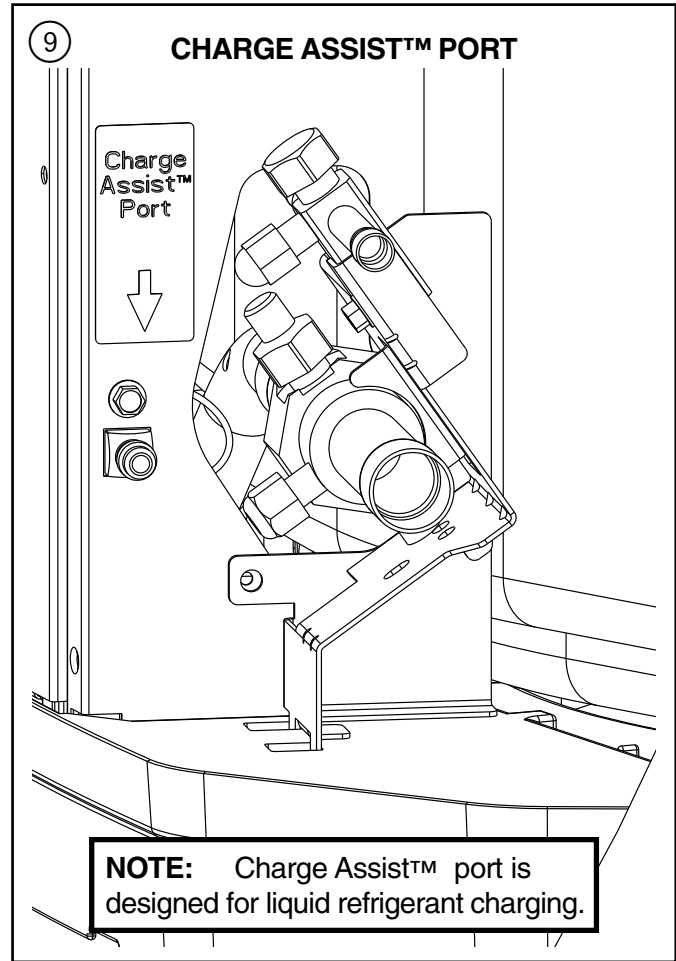
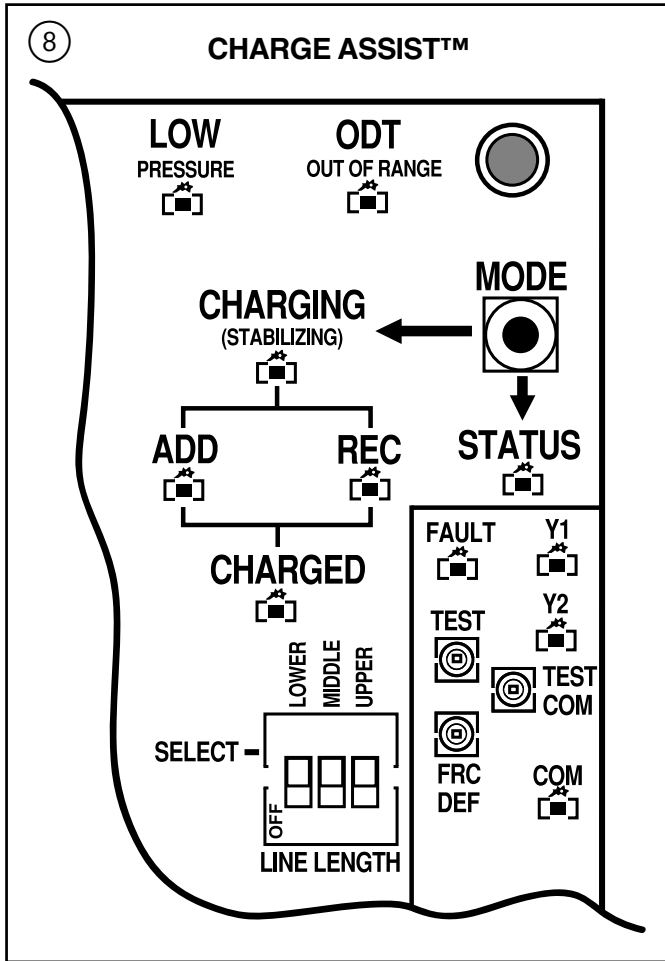

## DIRECTION FOR CHARGE ASSIST™

**NOTE:** Outdoor Temperature (ODT) must be between 65°F and 100°F.

Be sure to set Dip Switches for Line Length and Lift before entering Charge Assist™ Mode. (See Subcool Charging Table Corrections for Line Length and Rise in the Service Facts for the outdoor unit.)

To enter Charge Assist™ Mode, press the MODE button for at least one (1) second. The on-board LEDs will indicate if the system is capable of continuing. For a detailed description of on-board LEDs and their function, see the Charge Assist™ Procedure (18-AC72D1-\*) contained in the Outdoor Unit (the position of the \* denotes the latest revision number).

The system will take approximately 12-20 minutes to stabilize before the charge can be checked by Charge Assist™. Once the system is stabilized, watch to see which LED turns on next. If the

system charge is correct, the “CHARGED” LED will turn on and remain on for one (1) hour. Once charged, the system will exit Charge Assist™ and control will return to the Comfort Control.

If the system charge is low, the “ADD” LED will turn on and stay on up to one (1) hour or until enough refrigerant is added to reach the required system charge level and turn on the “CHARGED” LED.

When the “ADD” LED is on, the charging solenoid output will be active. This feature works to automatically control refrigerant flow with BAYCAKT001.

If the system charge is high, the “REC” LED will turn on and the unit will exit Charge Assist™. You must recover refrigerant from the system before re-entering Charge Assist™.

For instructions on the Charge Assist™ tool BAYCAKT001, see the Installer's Guide 18-HH15D1-\* (the position of the \* denotes the latest revision number).

*For additional information on manual charging, please see the Service Facts shipped with the outdoor unit.*

## 2TWZ9 OUTLINE DRAWING

NOTE: ALL DIMENSIONS ARE IN MM (INCHES).

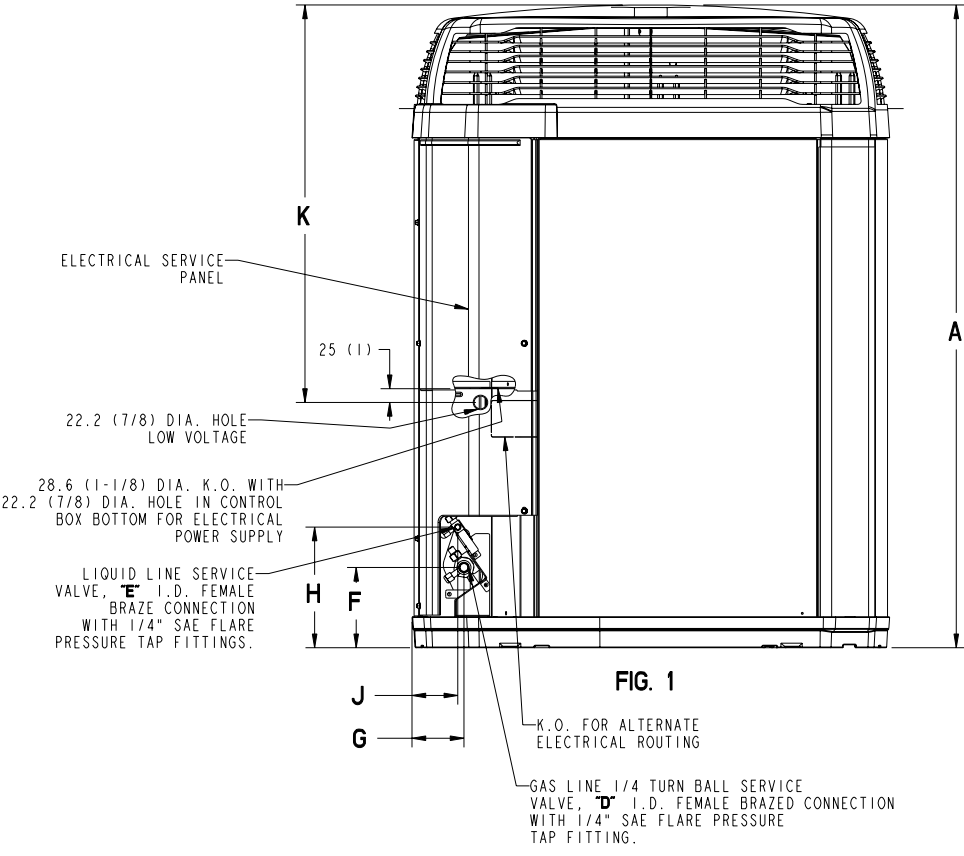
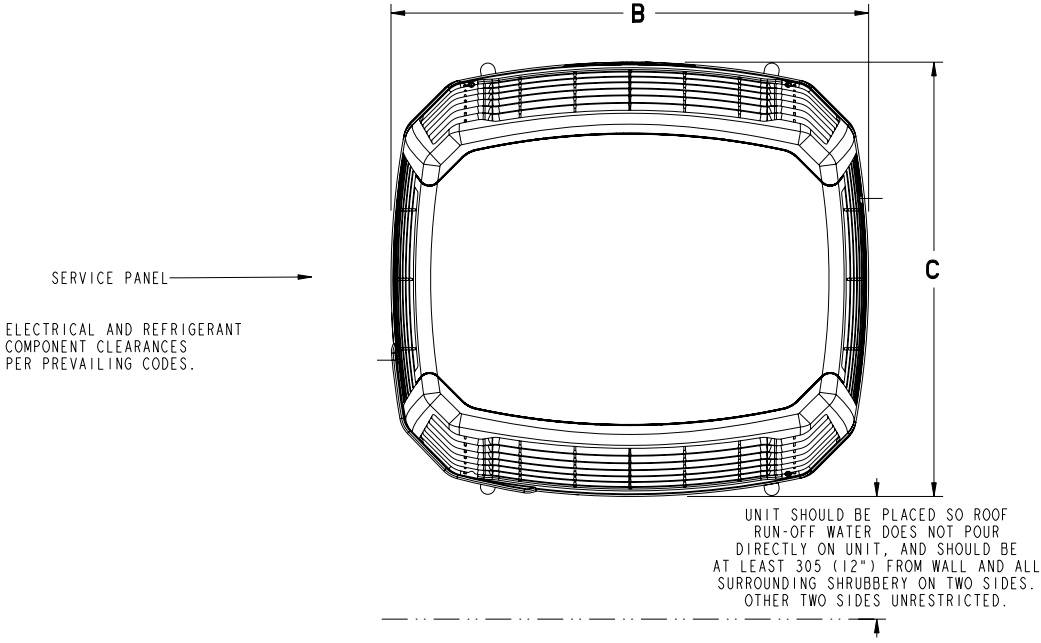

MODELS	BASE	A	B	C	D	E	F	G	H	J	K
2TWZ9030C	4	1267 (49-7/8)	946 (37-1/4)	870 (34-1/4)	7/8	3/8	152 (6)	98 (3-7/8)	219 (8-5/8)	86 (3-3/8)	933 (36-3/4)
2TWZ9036C	4	1267 (49-7/8)	946 (37-1/4)	870 (34-1/4)	7/8	3/8	152 (6)	98 (3-7/8)	219 (8-5/8)	86 (3-3/8)	933 (36-3/4)
2TWZ9048C	4	1267 (49-7/8)	946 (37-1/4)	870 (34-1/4)	1-1/8	3/8	152 (6)	98 (3-7/8)	219 (8-5/8)	86 (3-3/8)	933 (36-3/4)
2TWZ9060C	4	1267 (49-7/8)	946 (37-1/4)	870 (34-1/4)	1-1/8	3/8	152 (6)	98 (3-7/8)	219 (8-5/8)	86 (3-3/8)	933 (36-3/4)

From Dwg. 21D152635 Rev. 14

# Installer's Guide

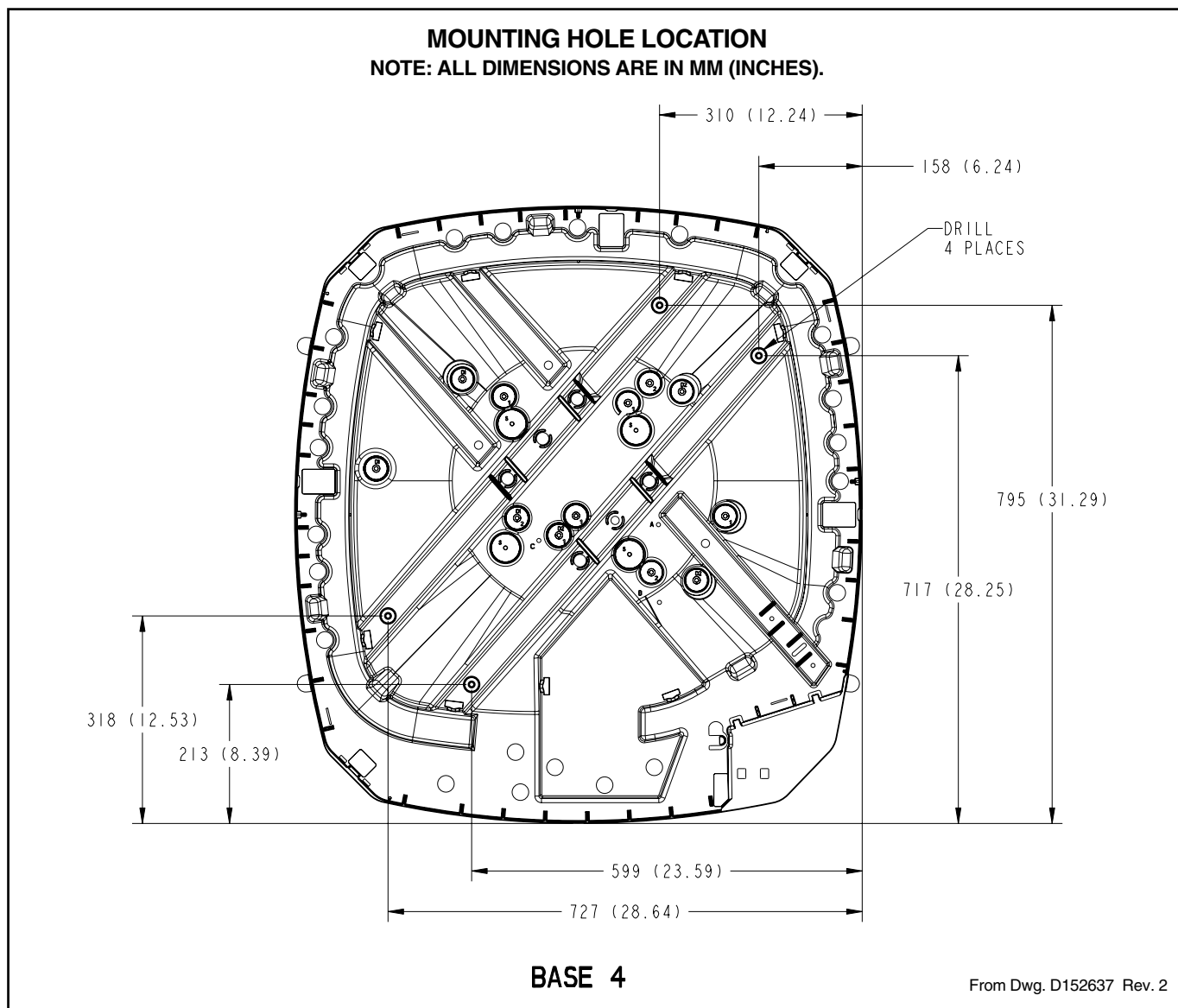

## CHECKOUT PROCEDURE

After installation has been completed, it is recommended that the entire system be checked against the following list:

- |  |     |   |     |
|--|-----|---|-----|
| 1. Refrigerant Line, Leak checked .....  | [ ] | 8. Supply registers and return grilles open and unobstructed .....  | [ ] |
| 2. Suction Lines and Fittings properly insulated .....   | [ ] | 9. Return air filter installed .....  | [ ] |
| 3. Have all Refrigerant Lines been secured and isolated properly? .....  | [ ] | 10. ComfortLink™ II control is accurate. Check against a reliable thermometer. Adjust per instructions with ComfortLink™ II control ..... | [ ] |
| 4. Have passages through masonry been sealed? If mortar is used, prevent mortar from coming into direct contact with copper tubing ..... | [ ] | 11. Is correct speed tap being used? (Indoor blower motor) .....  | [ ] |
| 5. Verify tightness of all electrical connects .....   | [ ] | 12. Operate complete system in each mode to insure safe operation. ....   | [ ] |
| 6. Observe outdoor fan during on cycle for clearance and smooth operation .....  | [ ] |   |     |
| 7. Indoor coil drain line drains freely. Pour water into drain pan .....   | [ ] |   |     |



Trane  
www.trane.com



ARI Standard  
210/240 UHP

Trane has a policy of continuous product and product data improvement and it reserves the right to change design and specifications without notice.