



## Horizontal Conversion Kit

Kits used to convert 4PXC\*U dedicated Upflow coil to Horizontal Left or Horizontal Right or convert 4PXC\*D dedicated Downflow coil to Horizontal Right

**BAYCONV18A**  
**BAYCONV23A**  
**BAYCONV27A**  
**BAYCONV30A**

**ALL phases of this installation must comply with NATIONAL, STATE AND LOCAL CODES**

**IMPORTANT** — This Document is **customer property** and is to remain with this unit. Please return to service information pack upon completion of work.

### ⚠ WARNING

**WARNING (Medium/high pressure)**

**Contains Refrigerant!**

System contains oil and refrigerant under high pressure. Recover refrigerant to relieve pressure before opening the system. See unit nameplate for refrigerant type. Do not use non-approved refrigerants, refrigerant substitutes, or refrigerant additives.

Failure to follow proper procedures or the use of non-approved refrigerants, substitutes, or refrigerant additives could result in death, serious injury, or equipment damage.

### A. GENERAL

These kits are designed for use in combination with a 4PXC coil to convert the coil for horizontal use. Dedicated upflow coils may be converted to either horizontal left or horizontal right. Dedicated downflow coils may only be converted to horizontal right.

The 4PXC equipment has been evaluated in accordance with the Code of Federal Regulations, Chapter XX, Part 3280 or the equivalent. "Suitable for Mobile Home use" The height of the Furnace, Coil and discharge duct work must be 7 ft. or less.

Inspect the kit components for shipping damage. Notify the transportation company immediately if the coil is damaged.

### B. KIT COMPONENTS

Item	Qty	Description
1	1	Horizontal Drain Pan
2	2	Condensate Drain Plugs
3	1	Splash Guard
4	1	Channel for Splash Guard

NOTE: All items are used for horizontal left conversion. Only items 1 and 2 are used for horizontal right conversion.

### ⚠ CAUTION

**Caution:** This coil is pressurized with 8-12 psig of dry air. Do not stand directly in front of the coil connections when removing sealing plugs. If no pressure is released, check for leaks.

### IMPORTANT:

To ensure maximum performance, make sure the arrow label on the coil cabinet matches the furnace airflow.

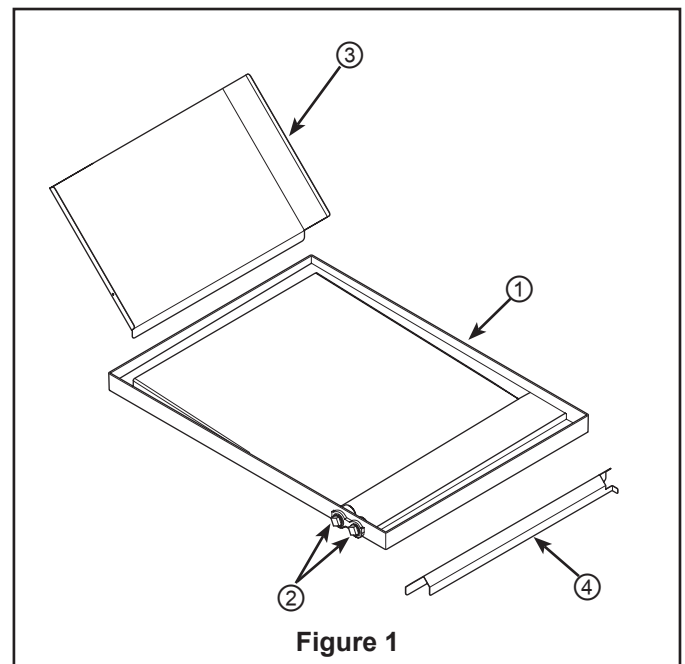

Figure 1

# Installer's Guide

## C. APPLICATION INFORMATION

### 1. FURNACE AND COIL

The coil **MUST BE** installed downstream (in the outlet air) of the furnace. The coil apex can face into or away from the direction of the airflow, depending on horizontal left or right application.

See the table below to verify the coil and kit match. The application specific sections will show what changes are needed for the coils.

Model Number	Allowable Installations	Horizontal Kit No.
4PXCAU24BS3HAA 4PXCBU24BS3HAA 4PXCBU30BS3HAA 4PXCCU30BS3HAA	Upflow, Horizontal Left or Horizontal Right	BAYCONV18A
4PXCAD24BS3HDA 4PXCBD24BS3HDA 4PXCBD30BS3HDA 4PXCCD30BS3HDA	Downflow or Horizontal Right Only	
4PXCBU36BS3HAA 4PXCCU36BS3HAA	Upflow, Horizontal Left or Horizontal Right	BAYCONV23A
4PXCBD36BS3HDA 4PXCCD36BS3HDA	Downflow or Horizontal Right Only	
4PXCBU42BS3HAA 4PXCCU42BS3HAA 4PXCBU48BS3HAA 4PXCCU48BS3HAA 4PXCDD48BS3HAA	Upflow, Horizontal Left or Horizontal Right	BAYCONV27A
4PXCBD42BS3HDA 4PXCCD42BS3HDA 4PXCBD48BS3HDA 4PXCCD48BS3HDA 4PXCDD48BS3HDA	Downflow or Horizontal Right Only	
4PXCCU60BS3HAA 4PXCDD60BS3HAA	Upflow, Horizontal Left or Horizontal Right	BAYCONV30A
4PXCCD60BS3HDA 4PXCDD60BS3HDA	Downflow or Horizontal Right Only	

## D. RECOMMENDATION

Use the Installer's Guide packaged with the coil for the physical installation of the coil.

If a coil is part of the total system installation, use the Installer's Guide packaged with the furnace, outdoor section, and thermostat for physically installing those components.

### ⚠ CAUTION

**Caution:** This coil is pressurized with 8-12 psig of dry air. Do not stand directly in front of the coil connections when removing sealing plugs. If no pressure is released, check for leaks.

#### IMPORTANT:

To ensure proper operation, make sure the arrow label on the coil cabinet matches the furnace airflow.

## E. CONVERSION FOR HORIZONTAL LEFT AIRFLOW APPLICATIONS.

### ⚠ CAUTION

**Both the coil and furnace must be fully supported. Do not attempt to suspend the coil using the alignment brackets.**

### ⚠ CAUTION

**Dedicated downflow coils may NOT be installed in the horizontal left position.**

1. HORIZONTAL LEFT COIL CONVERSION (All coils)
  - a. Remove coil front panels.
  - b. Slide out the coil assembly.
  - c. Remove the coil retainer bracket.

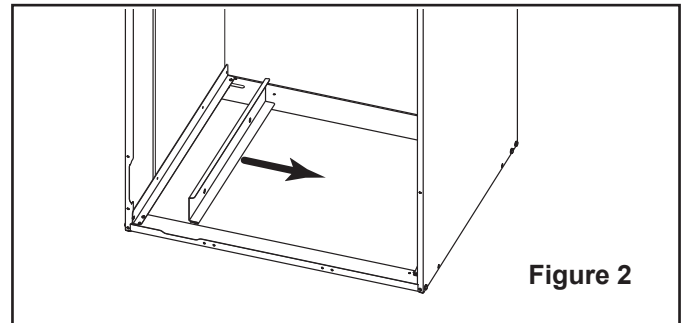

Figure 2

- d. Place U-channel into drain pan. See Figure 3.

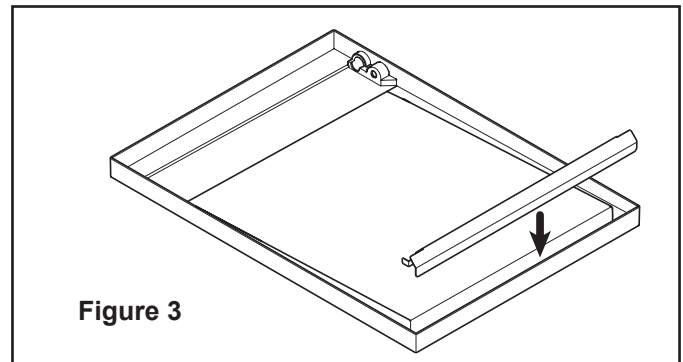

Figure 3

- e. Slide the new horizontal drain pan onto the coil and slide back into the coil cabinet. See Figure 4.

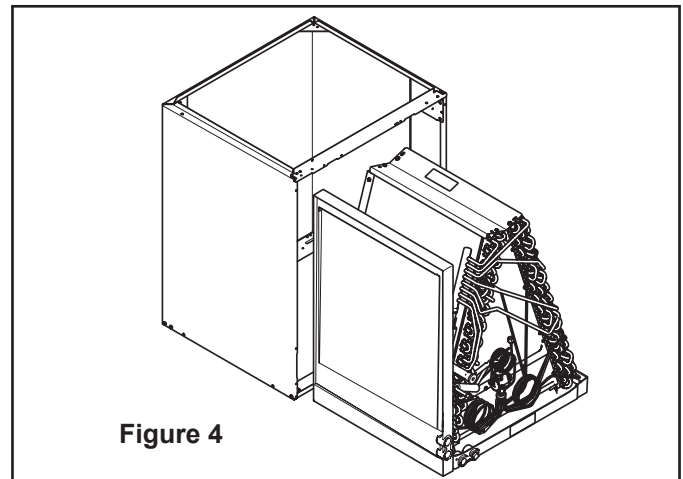

Figure 4

f. The splash guard packaged with the coil is for horizontal left coil installation only. The guard has a bend which is inserted into the front channel of the horizontal drain pan on the outlet air side of the coil case. The guard is then rotated downward until it rests in the drain pan. One field supplied sheet metal screw is driven through the coil case duct flange on the front side and into the splash guard side hole. See Figure 5.

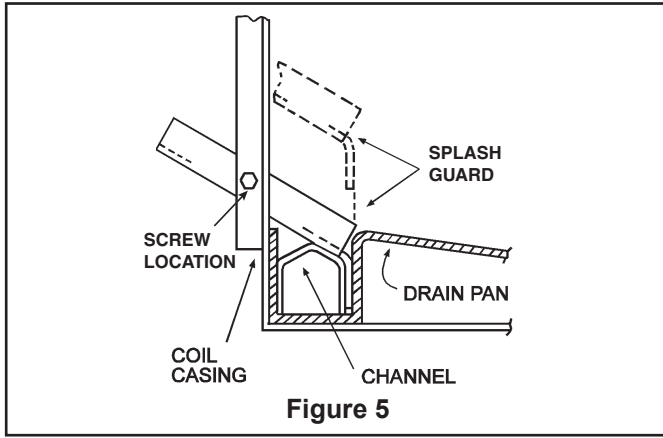

Figure 5

**NOTE:** In horizontal left, the 4PXC coil case is rotated so the apex of the coil is away from the furnace.

**NOTE:** The two piece baffle ships installed on the coil and is required for horizontal left applications.

g. Attach the coil to the furnace. Horizontal left coils will require connection brackets if no furnace flange is present. See Figure 6. If furnace flange is present, use standoffs and screws provided with the upflow furnace. If furnace flange is present, use field provided screws no longer than 1.5" to attach furnace to cased coil in the four obround holes on the sides of the cased coil. See furnace installer guide for instructions.

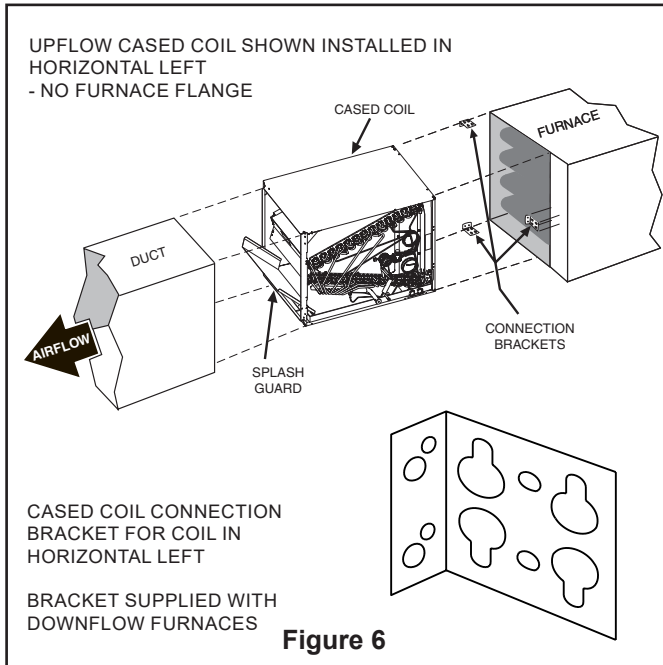

Figure 6

## ⚠ CAUTION

**Both the coil and furnace must be fully supported. Do not attempt to suspend the coil using the alignment brackets.**

- h. Cut insulation on the panel for horizontal drain pan. Remove the cap.
- i. Remove the plugs from the horizontal drain pan.
- j. Install plugs into the upflow drain pan.

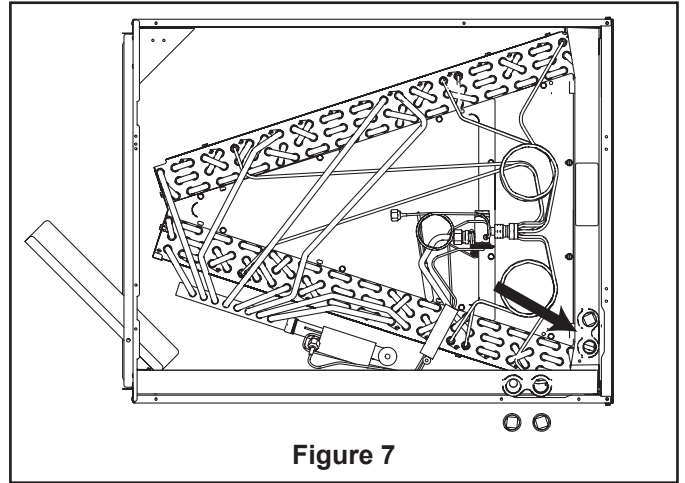

Figure 7

## F. MAXIMUM AIRFLOW SETTING, CFM, UPFLOW

**NOTE:** Water blow-off could occur in certain installation positions if the airflow setting exceeds the maximum values listed.

Maximum airflow setting, CFM			
Coil	Upflow	Horizontal Left	Horizontal Right
4PXC*U24BS3HAA	900	800	900
4PXC*U30BS3HAA	1125	1000	1125
4PXC*U36BS3HAA	1350	1200	1350
4PXC*U42BS3HAA	1575	1400	1575
4PXC*U48BS3HAA	1800	1600	1800
4PXC*U60BS3HAA	2250	2000	2250

\* May be "A", "B", "C", or "D"

**G. CONVERSION FOR HORIZONTAL RIGHT APPLICATIONS.**

**⚠ CAUTION**

**Both the coil and furnace must be fully supported.**

1. HORIZONTAL RIGHT COIL CONVERSION (All coils)
  - a. Remove coil front panels.
  - b. Slide out the coil assembly.
  - c. Remove the coil retainer bracket.
  - d. For the 4PXCDD060 and 4PXCCD060 Coils Only, the (2) outer water diverter baffles should be removed for maximum efficiency. See Figure 8.
  - e. Slide the new horizontal drain pan onto the coil and slide back into the coil cabinet.

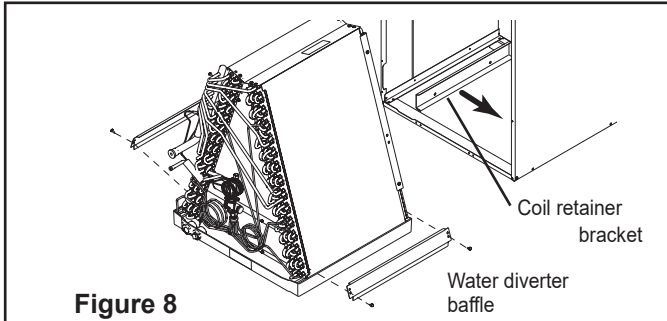

**NOTE: In horizontal right, the 4PXC coil case is rotated so the apex of the coil will point toward the furnace airflow. The auxiliary drain pan is now on the lower side.**

- f. Attach the coil to the furnace. Horizontal right coils will require connection brackets if no furnace flange is present. See Figure 9. If furnace flange is present, use field provided screws no longer than 1.5" to attach furnace to cased coil in the four obround holes on the sides of the cased coil. See Figure 10.

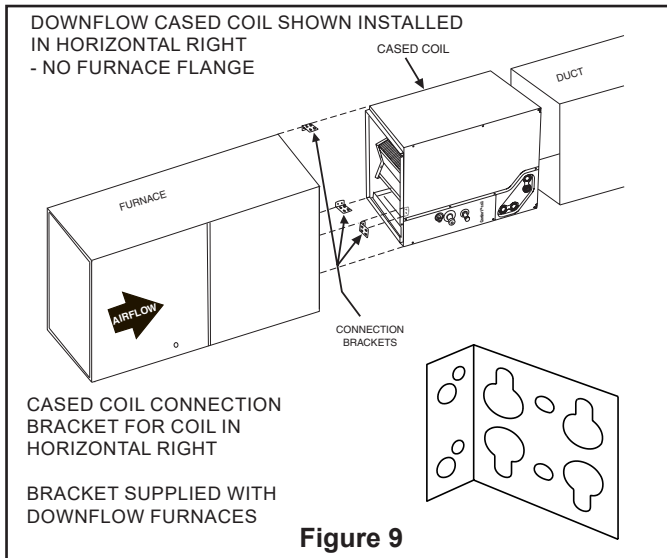

**Figure 9**

DOWNFLOW CASED COIL SHOWN INSTALLED IN HORIZONTAL RIGHT - WITH FURNACE FLANGE

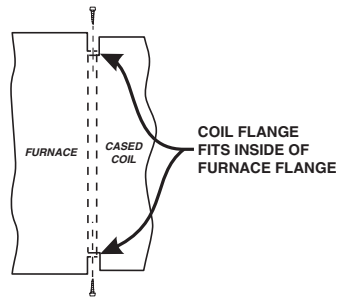
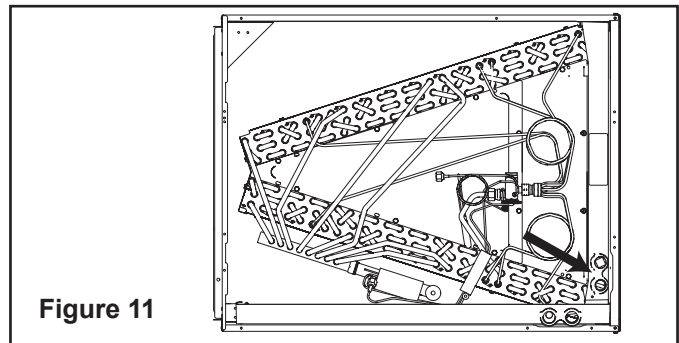

**Figure 10**

**⚠ CAUTION**

**Both the coil and furnace must be fully supported. Do not attempt to suspend the coil using the alignment brackets.**

- g. Cut insulation on door for horizontal drain pan. Remove the cap.
- h. Remove the plugs from the horizontal drain pan.
- i. Install plugs into the downflow drain pan.



**Figure 11**

**⚠ CAUTION**

**Caution: This coil is pressurized with 8-12 psig of dry air. Do not stand directly in front of the coil connections when removing sealing plugs. If no pressure is released, check for leaks.**

**H. MAXIMUM AIRFLOW SETTING, CFM, DOWNFLOW**

**NOTE: Water blow-off could occur in certain installation positions if the airflow setting exceeds the maximum values listed.**

Maximum airflow setting, CFM		
Coil	Downflow	Horizontal Right
4PXC*D24BS3HDA	750	900
4PXC*D30BS3HDA	925	1125
4PXC*D36BS3HDA	1100	1350
4PXC*D42BS3HDA	1300	1575
4PXC*D48BS3HDA	1475	1800
4PXC*D60BS3HDA	1850	2250

\* May be "A", "B", "C", or "D"

**About Trane and American Standard Heating and Air Conditioning**

Trane and American Standard create comfortable, energy efficient indoor environments for residential applications. For more information, please visit [www.trane.com](http://www.trane.com) or [www.americanstandardair.com](http://www.americanstandardair.com)

The manufacturer has a policy of continuous data improvement and it reserves the right to change design and specifications without notice. We are committed to using environmentally conscious print practices.