



Cased Aluminum "Convertible" Coils

Models:

4TXCA002DS3HCA	4TXCC005DS3HCA
4TXCA032DS3HCA	4TXCC007DS3HCA
4TXCB003DS3HCA	4TXCD008DS3HCA
4TXCB004DS3HCA	4TXCC009DS3HCA
4TXCB006DS3HCA	4TXCD010DS3HCA

ALL phases of this installation must comply with NATIONAL, STATE AND LOCAL CODES

IMPORTANT — This Document is **customer property** and is to remain with this unit. Please return to service information pack upon completion of work.

⚠ WARNING

WARNING (Medium/high pressure)
Contains Refrigerant!

System contains oil and refrigerant under high pressure. Recover refrigerant to relieve pressure before opening the system. See unit nameplate for refrigerant type. Do not use non-approved refrigerants, refrigerant substitutes, or refrigerant additives.

Failure to follow proper procedures or the use of non-approved refrigerants, substitutes, or refrigerant additives could result in death, serious injury, or equipment damage.

⚠ WARNING

This product can expose you to chemicals including lead, which are known to the State of California to cause cancer and birth defects or other reproductive harm. For more information go to www.P65Warnings.ca.gov

A. GENERAL

These coils are designed for use in combination with a heat pump or cooling outdoor section using **R-410A REFRIGERANT**.

The 4TXC equipment has been evaluated in accordance with the Code of Federal Regulations, Chapter XX, Part 3280 or the equivalent. "Suitable for Mobile Home use" The height of the Furnace, Coil and discharge duct work must be 7 ft. or less.

Inspect the coil for shipping damage. Notify the transportation company immediately if the coil is damaged.

B. APPLICATION INFORMATION

1. FURNACE AND COIL

The coil **MUST BE** installed downstream (in the outlet air) of the furnace.

2. INDOOR UNIT AIRFLOW

Indoor unit must provide the required airflow for the heat pump or cooling combinations approved for these coils.

Table of Contents

General	1
Application Information	1
Recommendation	2
Furnace in Upflow Position	2
Furnace in Downflow Position	2
Furnace in Horizontal Right Position.....	3
Furnace in Horizontal Left Position	4
Maximum Airflow Setting, CFM	5
Installing / Brazing Refrigerant Lines	5
Leak Check.....	6
Condensate Drain Piping.....	6
Cleaning the Coil.....	6
Outline Drawings.....	7
Troubleshooting Indoor TXV / Cooling Mode.....	10

NOTE:

OPTIONAL DOWNFLOW GASKET INSTALLATION: For unusually humid applications that expect prolonged operation above 70% RH, it is recommended to use the **BAYGSKT001A0** gasket kit to prevent water from forming on the bottom of the drain pan and dripping into the supply ductwork.

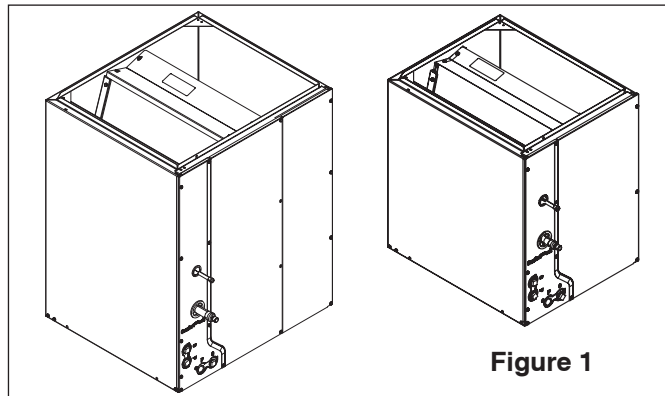

Figure 1

IMPORTANT: Review your installation requirements. Check the table on the outline drawings and note all dimensions for your coil before beginning the installation.

Installer's Guide

C. RECOMMENDATION

If a coil is part of the total system installation, use the Installer's Guide packaged with the furnaces, outdoor sections, and thermostat for physically installing those components.

CAUTION

Caution: This coil is pressurized with 8-12 psig of dry air. Do not stand directly in front of the coil connections when removing sealing plugs. If no pressure is released, check for leaks.

D. FURNACE IN UPFLOW POSITION

1. UPFLOW COIL CONVERSION: While not required, optional removal of some coil components will maximize airflow efficiency.
 - a. Remove the coil by sliding the coil out of the coil enclosure.
 - b. Optional but recommended: Remove the factory installed two-piece baffle assembly from the top of the coil by removing the 5/16" hex head screws. See Figure 2. Replace only the top baffle using the same screws previously provided.
 - c. Optional but recommended: On 4TXCC009DS and 4TXCD010DS only, remove the (2) outer water diverter baffles by removing the 5/16" hex head screws. See Figure 5.
 - d. Optional for maximum efficiency: Remove the horizontal drain pan from the coil and discard.
2. UPFLOW GAS FURNACE
 - a. Apply gasket material (duct seal field supplied) to ALL mating surfaces between the furnace and the coil case.
 - b. Set the coil case on top of the furnace. Connect the ductwork to the coil case using field supplied screws.
 - c. Secure the coil case to the furnace and seal for air leaks as required.

E. FURNACE IN DOWNFLOW POSITION

1. DOWNFLOW COIL CONVERSION: While not required, optional removal of some coil components will maximize airflow efficiency.
 - a. Remove the coil by sliding the coil out of the coil enclosure.
 - b. Optional but recommended: Remove the factory installed two-piece baffle assembly from the top of the coil by removing the 5/16" hex head screws. See Figure 2. Replace only the top baffle using the same screws previously provided.
 - c. Optional for maximum efficiency: Remove the horizontal drain pan from the coil and discard.
2. DOWNFLOW GASKET INSTALLATION (OPTIONAL): For unusually humid applications that expect prolonged operation above 70% RH, it is recommended to use the BAYGSK-T001A0 gasket kit to prevent water from forming on the bottom of the drain pan and dripping into the supply ductwork.
 - a. Lay the coil on its back side.
 - b. Locate the 4" wide gasket material found in BAYGSKT001A0.
 - c. Attach the 4" gasket material to three sides of the bottom of the drain pan as shown. Make sure to start by matching up the edge of the gasket material to the inner edge of the drain pan by the coil fins and working outwards.
 - d. The gasket material can be cut or ripped easily so that it can be tailored to fit. The gasket material must cover the three sides along the entire length of the coil as shown in Figure 4.

3. DOWNFLOW GAS FURNACE

When a coil is used with a downflow furnace, a subbase is not required between the coil case and combustible flooring.

- a. Place the coil case on the furnace supply air plenum.
- b. Secure the coil case to the plenum.
- c. Set the furnace on top of the coil case, making sure that the back side of the discharge opening is snug up against the duct flange at the top rear of the coil case.
- d. Secure the coil case to the furnace and seal for air leaks as required.

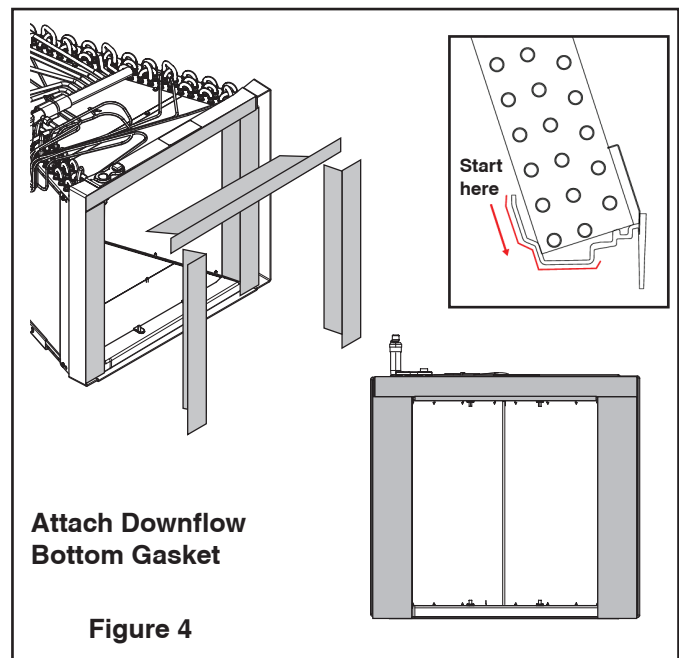
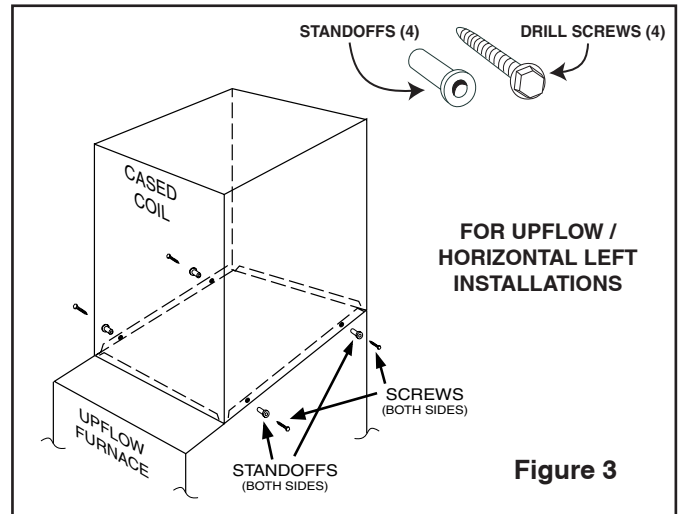
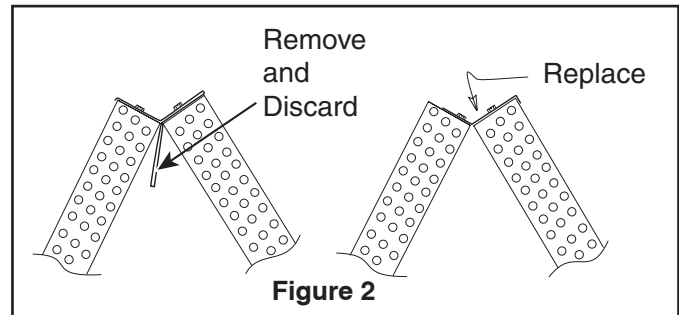

F. FURNACE IN HORIZONTAL RIGHT POSITION

⚠ CAUTION

Both the coil and furnace must be fully supported. Do not attempt to suspend the coil using the brackets.

Note: when installing onto an S-Series furnaces in horizontal right or downflow configuration the flanges will be bent downward.

1. HORIZONTAL RIGHT COIL CONVERSION: While not required, optional removal of some coil components will maximize airflow efficiency.
 - a. Remove the coil by sliding the coil out of the coil enclosure.
 - b. Optional but recommended: Remove the factory installed two-piece baffle assembly from the top of the coil by removing the 5/16" hex head screws. See Figure 2. Replace only the top baffle using the same screws previously provided.
 - c. Optional but recommended: On 4TXCC009DS and 4TXCD010DS only, remove the (2) outer water diverter baffles by removing the 5/16" hex head screws. See Figure 6.

IMPORTANT:

The 4TXC cased coil must be placed downstream of the furnace. See Figure 6 for proper orientation.

2. When the noncondensing Upflow/Horizontal furnace is placed on its right side for right airflow, the furnace top flange meets the cased coil top flange. The coil flange fits inside of the furnace flange. See Figure 7.
3. There are self drilling screws included which can be used for this connection. Seal all gaps between the furnace and coil.

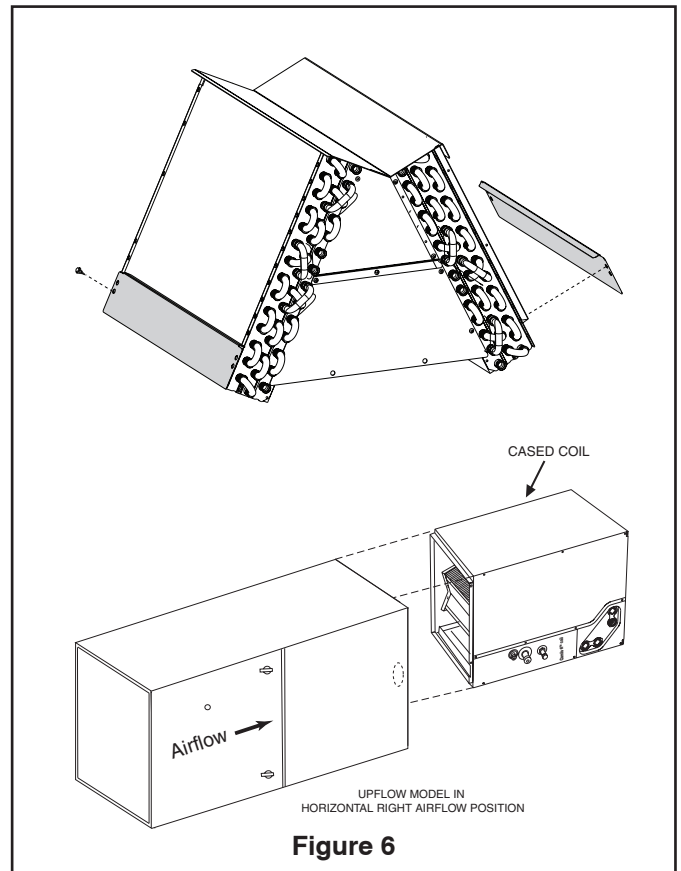

Figure 6

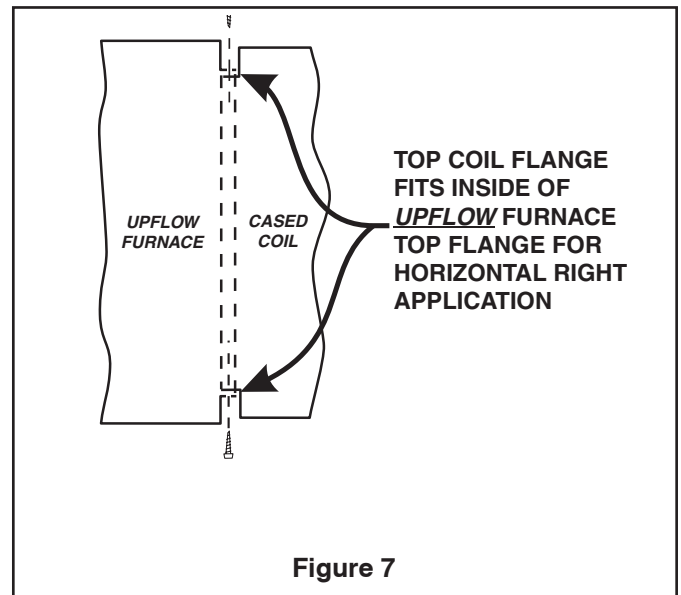

Figure 7

Note: when installing coil onto an S-Series furnaces in horizontal right or downflow configuration, bend the flanges downward for a flush fit.

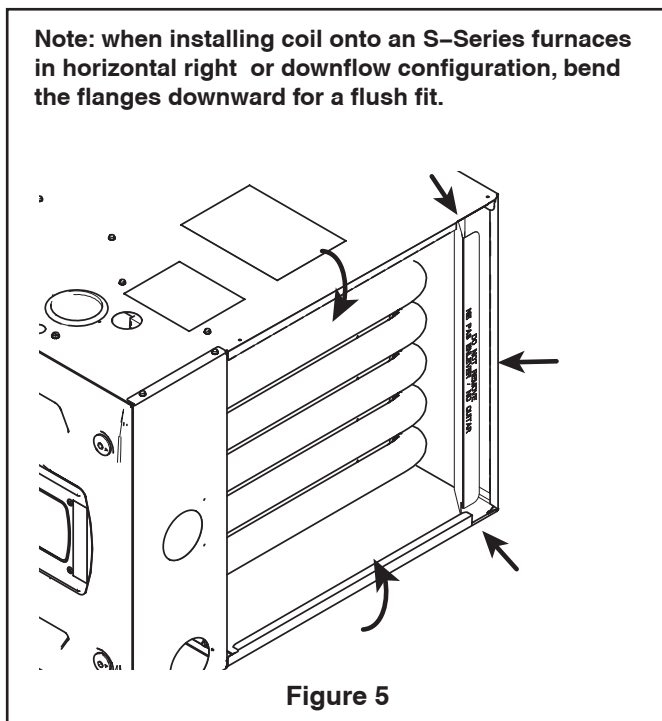

Figure 5

Installer's Guide

G. FURNACE IN HORIZONTAL LEFT POSITION

CAUTION

Both the coil and furnace must be fully supported. Do not attempt to suspend the coil using the brackets.

1. HORIZONTAL LEFT COIL CONVERSION: While not required, optional removal of some coil components will maximize airflow efficiency.
 - a. Remove the coil by sliding the coil out of the coil enclosure.
 - b. Optional but recommended: On 4TXCC009DS and 4TXCD010DS only, remove the (2) outer water diverter baffles by removing the 5/16" hex head screws. See Figure 8.

2. HORIZONTAL LEFT (All coils)

The non-condensing furnaces may be laid on either side for horizontal application. The condensing downflow/horizontal and upflow/horizontal furnaces may only be rotated onto their left side. Connection brackets for coil/furnace alignment are included with the furnaces.

a. In horizontal left, the 4TXC coil case is rotated so the apex of the coil is away from the furnace and the auxiliary drain pan is now on the lower side.

b. The two piece baffle ships installed on the coil and is required for horizontal left applications.

c. The base of the coil enclosure is placed flush against the downflow/horizontal furnace. Upflow/horizontal condensing furnaces have the coil match the top flange.

d. There are three brackets included with the non-condensing downflow furnace which are used to connect the furnace and coil together. See Figure 9.

e. Two brackets are used to attach the rear of the coil and furnace and one bracket is used to attach the front. The rear brackets will use existing screws on the coil enclosure (two on each side at the bottom). Each of the rear brackets will be attached with the wide side of the bracket resting on the top and bottom of the horizontal coil and furnace (see Figure 10). Four additional screws will be used to attach each rear bracket.

f. The front bracket is positioned as close to the center as possible with the narrow edge against the coil enclosure and the wide edge against the furnace. Two screws each are driven into the coil enclosure and furnace.

g. There is a splash guard packaged with the coil. This guard is for horizontal left coil installation only. The guard has a bend which is inserted into the front channel of the horizontal drain pan on the outlet air side of the coil case. The guard is then rotated downward until it rests in the drain pan. One sheet metal screw is driven through the coil case duct flange on the front side and into the splash guard side hole. See Figure 11.

Standoffs and screws (See Figure 3) are included with the cased coils for attachment to the furnace. There are clearance alignment holes near the bottom of the coil wrapper. Drill screws are used to engage the top flanges of the furnace. The standoff is inserted into the cabinet alignment hole (See Figure 3). The drill screws are inserted through the standoffs then screwed into the furnace top flange. The coil is always placed downstream of the furnace airflow. The coil and furnace must be fully supported when used in the horizontal position. The standoffs and screws are strictly for securing alignment, not for support in horizontal.

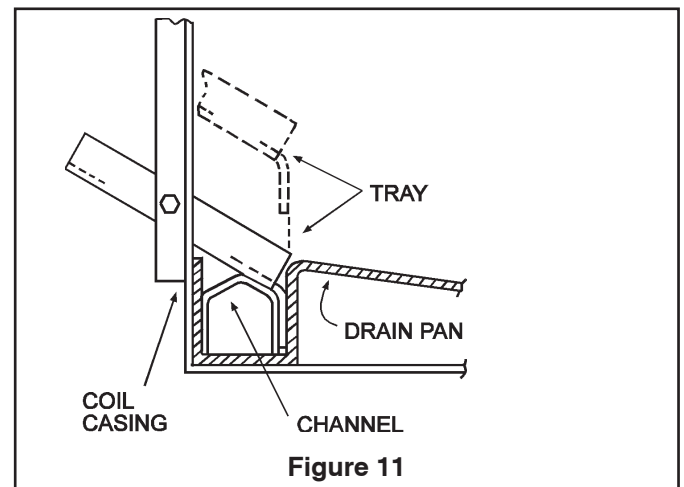
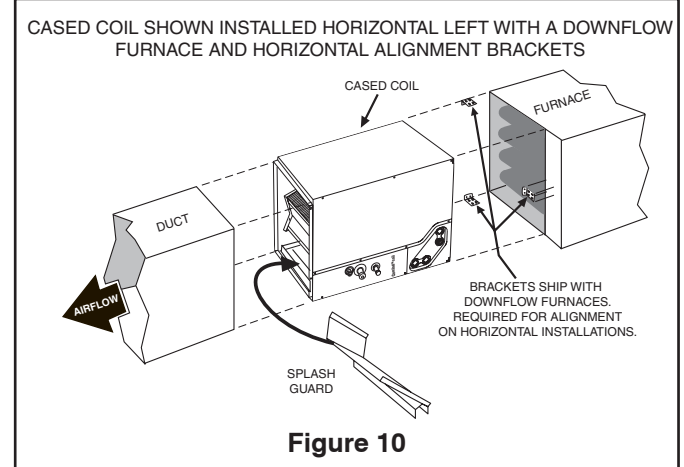
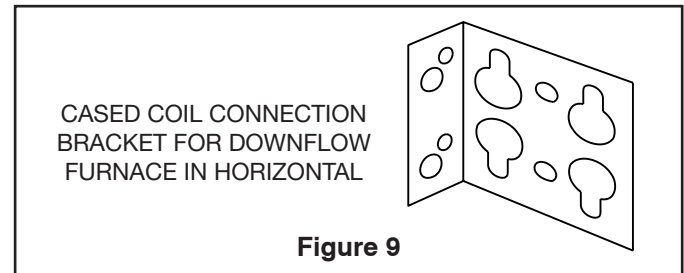
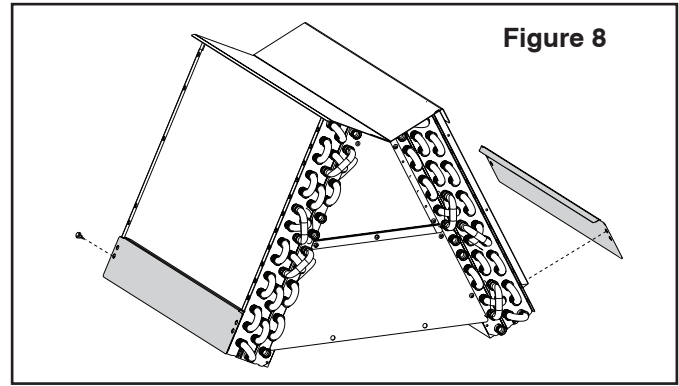

H. MAXIMUM AIRFLOW SETTING, CFM

NOTE:

Water blow-off could occur in certain installation positions if the airflow setting exceeds the maximum values listed.

Maximum airflow setting, CFM		
Coil	Upflow	Horizontal Left
4TXCA002DS3HCA	900	800
4TXCA032DS3HCA	1350	1125
4TXCB003DS3HCA	1125	1000
4TXCB004DS3HCA	1350	1200
4TXCC005DS3HCA	1350	1200
4TXCB006DS3HCA	1800	1600
4TXCC007DS3HCA	1800	1600
4TXCD008DS3HCA	1800	1600
4TXCC009DS3HCA	2250	2000
4TXCD010DS3HCA	2250	2000
Coil	Downflow	Horizontal Right
4TXCA002DS3HCA	750	900
4TXCA032DS3HCA	1200	1350
4TXCB003DS3HCA	925	1125
4TXCB004DS3HCA	1100	1350
4TXCC005DS3HCA	1100	1350
4TXCB006DS3HCA	1475	1800
4TXCC007DS3HCA	1475	1800
4TXCD008DS3HCA	1475	1800
4TXCC009DS3HCA	1850	2250
4TXCD010DS3HCA	1850	2250

NOTE:

The TXV setting on this unit may run high superheat (15-25°F) by design when measured at the outdoor unit.

I. INSTALLING / BRAZING REFRIGERANT LINES

⚠ CAUTION

Do NOT open refrigerant valve at the outdoor unit until the refrigerant lines and coil have been brazed, evacuated, and leak checked. This would cause contamination of the refrigerant or possible discharge of refrigerant to the atmosphere.

1. The following steps are to be considered when installing the refrigerant lines:

- Determine the most practical way to run the lines.
- Consider types of bends to be made and space limitations.
- Route the tubing making all required bends and properly secure the tubing before making final connections.

NOTE: Refrigerant lines must be isolated from the structure and the holes must be sealed weather tight after installation.

IMPORTANT:

Do not unseal refrigerant tubing until ready to fit refrigerant lines.

There is only a holding charge of dry air in the indoor coil, therefore no loss of operating refrigerant charge occurs when the sealing plugs are removed.

NOTE:

TXV bulb MUST be protected (wrapped with wet rag) or removed, while brazing the tubing. Overheating of the sensing bulb will affect the functional characteristics and performance of the comfort coil.

- Remove both rubber plugs from the indoor coil.
- Field supplied tubing should be cut square, round and free of burrs at the connecting end. Clean the tubing to prevent contaminants from entering the system.
- Run the refrigerant tubing into the stub tube sockets of the indoor unit coil.

PAINTED AREAS OF THE UNIT MUST BE SHIELDED DURING BRAZING.

- Flow a small amount of nitrogen through the tubing while brazing.
- Use good brazing technique to make leakproof joints.
- Minimize the use of sharp 90 degree bends.
- Insulate the suction line and its fittings.
- Do NOT allow un-insulated lines to come into contact with each other.

Installer's Guide

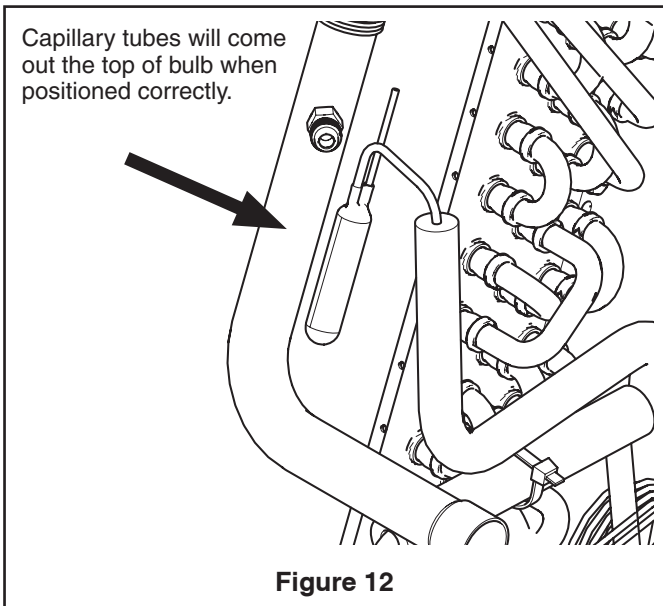

When replacing the bulb and hose clamp, the clamp should be "snug" but not "tight" - spec is to torque the hose clamp to 20+/-5in-lb.

9. Wrap the TXV with insulation after the hose clamp has been installed.

J. LEAK CHECK

1. Using a manifold gauge, connect an external supply of dry nitrogen to the gauge port on the liquid line.
2. Pressurize the connecting lines and indoor coil to 150 PSIG maximum.
3. Leak check brazed line connections using soap bubbles. Repair leaks (if any) after relieving pressure.
4. Evacuate and charge the system per the instructions packaged with the outdoor unit.

K. CONDENSATE DRAIN PIPING

Condensate drain connections are located in the drain pan at the bottom of the coil/enclosure assembly. The female threaded fitting protrudes outside of the enclosure for external connection. A field fabricated trap is not required for proper drainage due to the positive pressure of the furnace; however, it is recommended to prevent efficiency loss of conditioned air.

1. The drain hole in the drain pan must be cleared of all insulation.
2. Insulate the primary drain line to prevent sweating where dew point temperatures may be met. (Optional depending on climate and application needs)
3. Connect the secondary drain line to a separate drain line (no trap is needed in this line).

L. CLEANING THE COIL

The two piece door (3-piece on 24.5" wide models) allows removal of the outer casing doors without interference from refrigerant or condensate lines. Once the outer doors are removed the split inner coil panels can be easily removed. The inside and outside of the coil can be easily cleaned with a brush and vacuum with the panels removed. See Figure 13.

The foil covered insulation should be wiped down and residual dirt and dust should be vacuumed up to maintain good air quality. See Figure 14.

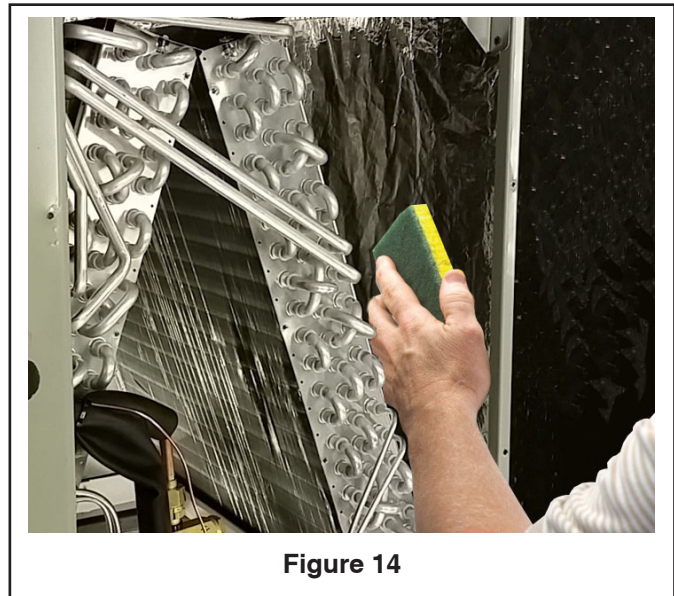
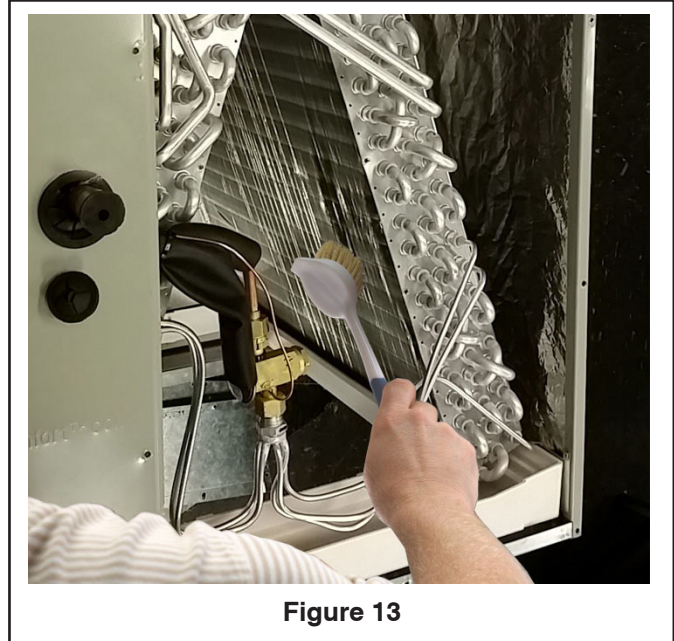

Outline Drawing for models: 4TXCB003DS3

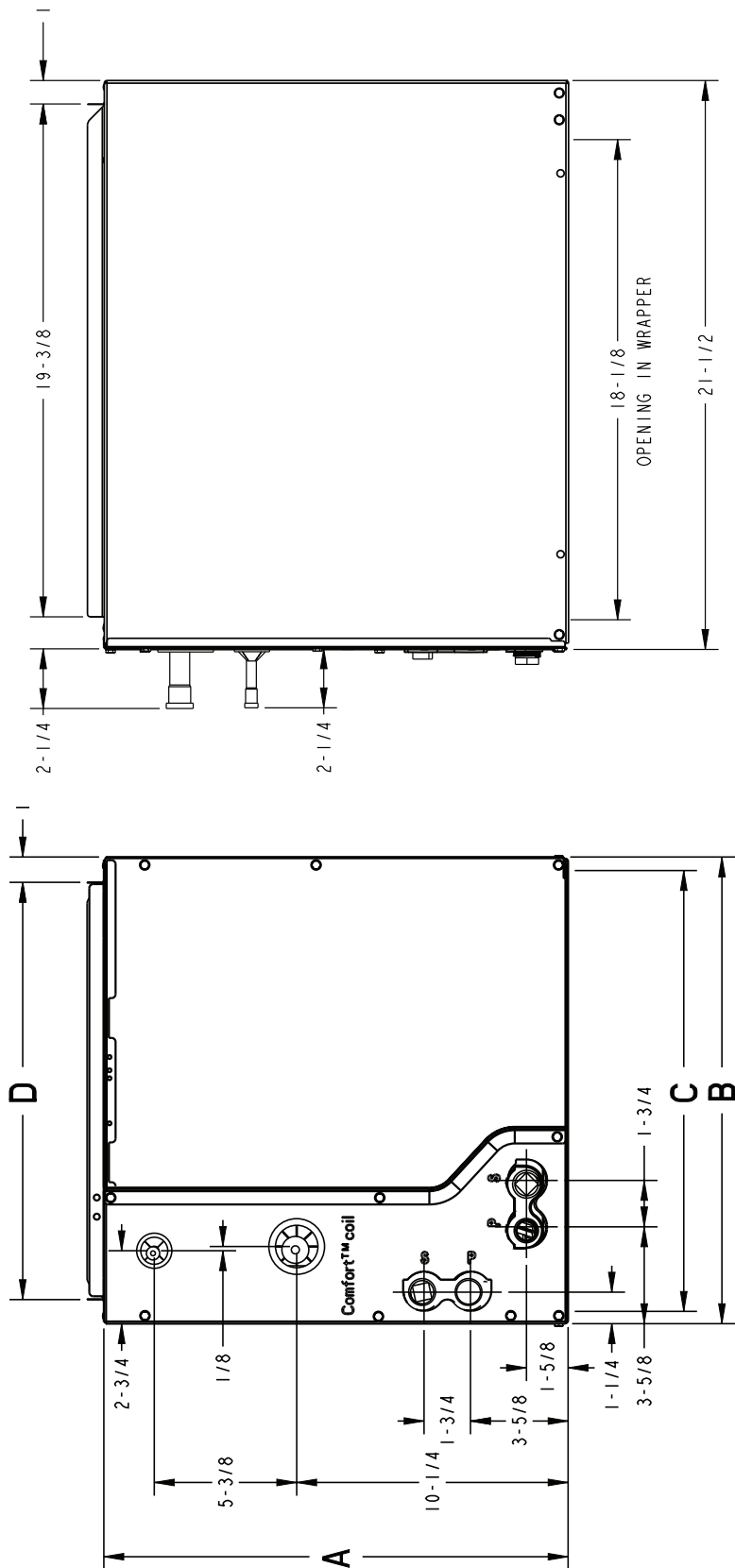

FIGURE B

MODEL	4TXCB003DS3
WEIGHT (LBS.)	50
REFRIGERANT CONTROL	TXV (NON-BLEED)
HEIGHT "A" (IN.)	17-1/2
OVERALL WIDTH "B" (IN.)	17-1/2
OPENING WIDTH "C" (IN.)	16-5/8
TOP OPENING "D"	15-3/4
GAS CONNECTION	3/4
LIQUID CONNECTION	3/8
MATCHED FURNACE WIDTH (NO ADAPTER REQUIRED)	17-1/2
DRAIN PAN	PLASTIC

From Dwg. D345686 RevA

Outline Drawing for Models: 4TXCD008DS3, 4TXCD010DS3

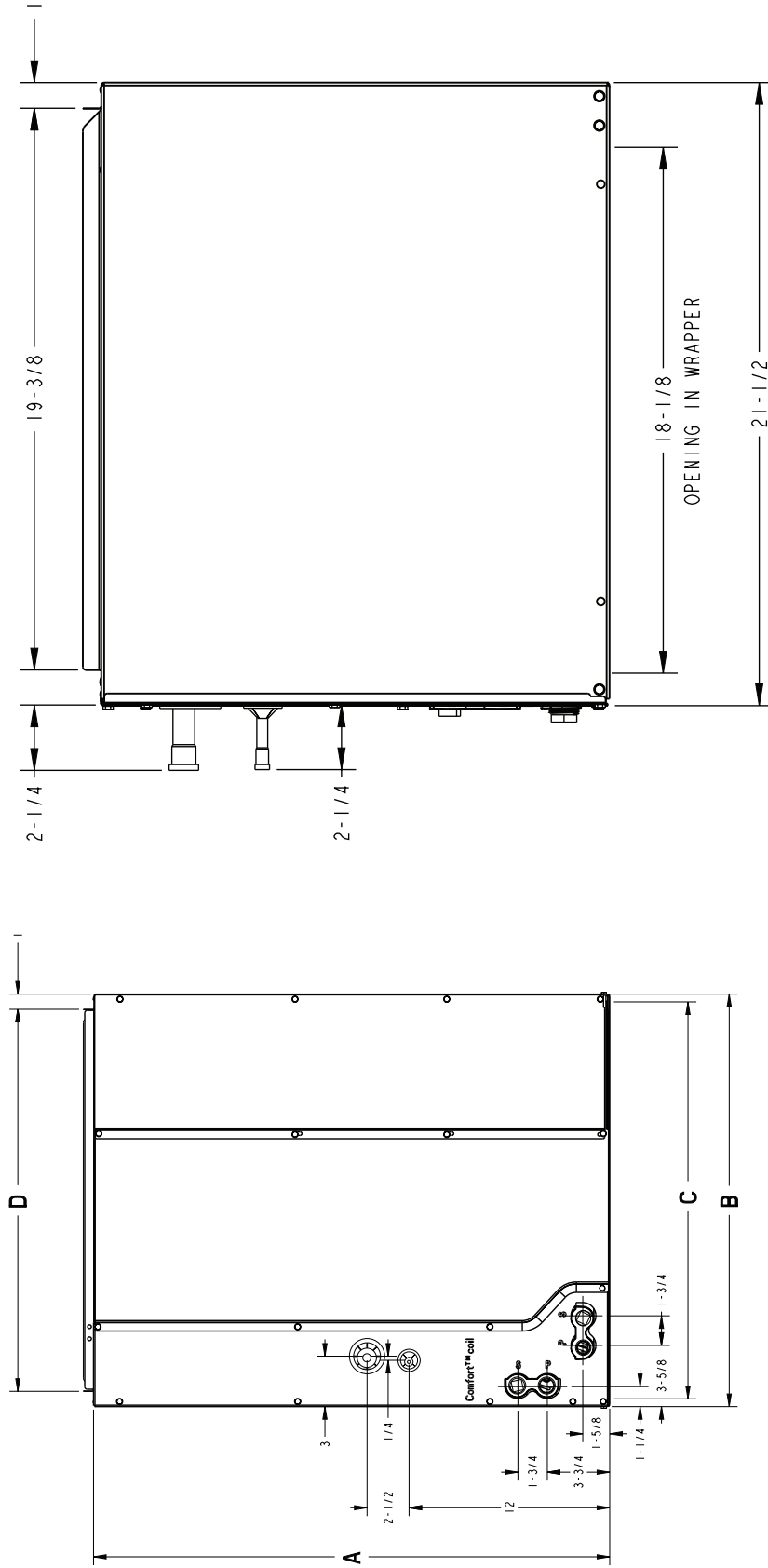

FIGURE C

MODEL	4TXCD008DS3	4TXCD010DS3
WEIGHT (LBS.)	72	81
REFRIGERANT CONTROL	TXV (NON-BLEED)	
HEIGHT "A" (IN.)	26-7/8	30-11/16
OVERALL WIDTH "B" (IN.)	24-1/2	24-1/2
OPENING WIDTH "C" (IN.)	23-5/8	23-5/8
TOP OPENING "D"	22-3/4	22-3/4
GAS CONNECTION	7/8	
LIQUID CONNECTION	3/8	
MATCHED FURNACE WIDTH (NO ADAPTER REQUIRED)	24-1/2	
DRAIN PAN	PLASTIC	

From Dwg. D345686 RevB

Installer's Guide

Before starting, insure the blower wheel, indoor and outdoor coils are clean.

Troubleshooting Indoor TXV / Cooling Mode

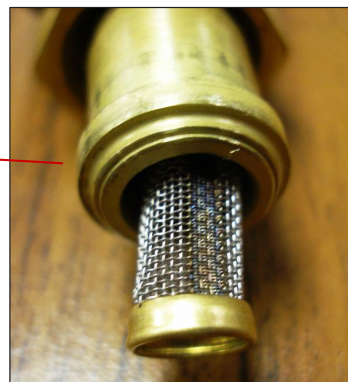
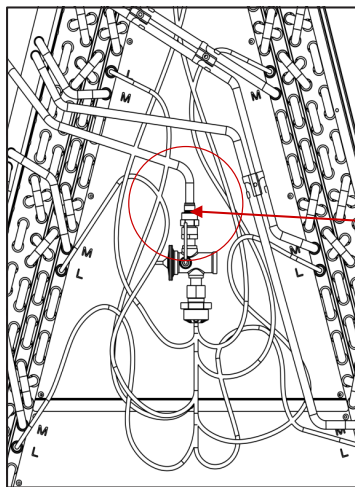
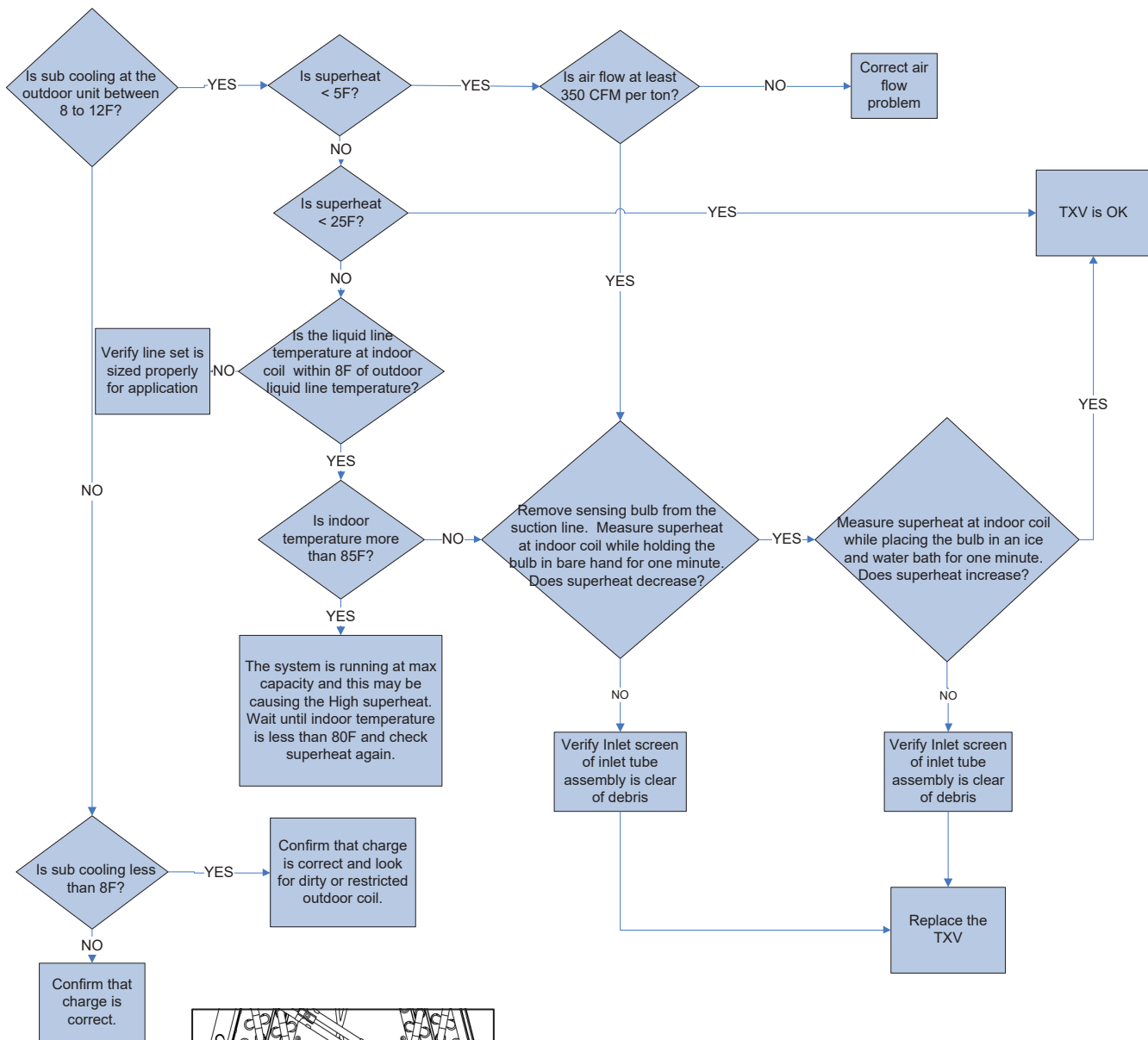

About Trane and American Standard Heating and Air Conditioning

Trane and American Standard create comfortable, energy efficient indoor environments for residential applications. For more information, please visit www.trane.com or www.americanstandardair.com

The manufacturer has a policy of continuous data improvement and it reserves the right to change design and specifications without notice. We are committed to using environmentally conscious print practices.

18-AD35D1-2E-EN 18 Jun 2020

Supersedes 18-AD35D1-2D-EN (December 2018)

© 2020