

Installer's Guide

Condensing Units

2TTZ9C with ComfortLink™ II and Charge Assist™

ALL phases of this installation must comply with NATIONAL, STATE AND LOCAL CODES

IMPORTANT — This Document is **customer property** and is to remain with this unit. Please return to service information pack upon completion of work.

These instructions do not cover all variations in systems nor provide for every possible contingency to be met in connection with installation. All phases of this installation must comply with NATIONAL, STATE AND LOCAL CODES. Should further information be desired or should particular problems arise which are not covered sufficiently for the purchaser's purposes, the matter should be referred to your installing dealer or local distributor.

A. GENERAL

WARNING

This information is intended for use by individuals possessing adequate backgrounds of electrical and mechanical experience. Any attempt to repair a central air conditioning product may result in personal injury and or property damage. The manufacturer or seller cannot be responsible for the interpretation of this information, nor can it assume any liability in connection with its use.

NOTICE:

Trane has always recommended installing Trane approved matched indoor and outdoor systems.

The benefits of installing approved matched systems are maximum efficiency, optimum performance and best overall system reliability.

Check for transportation damage after unit is uncrated. Report promptly, to the carrier, any damage found to the unit.

To determine the electrical power requirements of the unit, refer to the nameplate of the unit. The electrical power available must agree with that listed on the nameplate.

B. LOCATION AND PREPARATION OF THE UNIT

1. When removing unit from the pallet, notice the tabs on the basepan. Remove tabs by cutting with a sharp tool as shown in Figure 2 (see page 2).
2. The unit should be set on a level support pad at least as large as the unit base pan, such as a concrete slab. If this is not the application used please refer to application bulletin "Trane APB2001-02".
3. The support pad must NOT be in direct contact with any structure. Unit must be positioned a minimum of 12" from any wall or surrounding shrubbery to insure adequate airflow. Clearance must be provided in front of control box (access panels) & any other side requiring service access to meet National Electrical Code. Also, the unit location must be far enough away from any structure to prevent excess roof run-off water from pouring directly on the unit. Do not locate unit(s) close to bedroom(s).

5 FT. ABOVE UNIT — UNRESTRICTED

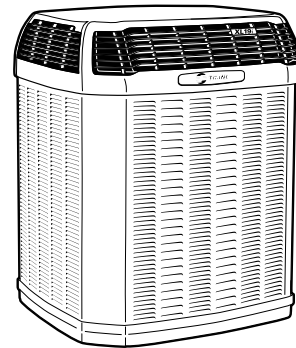

4. The top discharge area must be unrestricted for at least five (5) feet above the unit.
5. When the outdoor unit is mounted on a roof, be sure the roof will support the unit's weight. Properly selected isolation is recommended to prevent sound or vibration transmission to the building structure.
6. The maximum length of refrigerant lines from outdoor to indoor unit should NOT exceed sixty (60) feet.
7. If outdoor unit is mounted above the air handler, maximum lift should not exceed twenty-five (25) feet (suction line). If air handler is mounted above condensing unit, maximum lift should not exceed twenty-five (25) feet (liquid line).

NOTE:

Refer to "Refrigerant Piping Software" Pub. No. 32-3312-0* (the position of the * denotes the latest revision number).

8. Locate and install indoor coil or air handler in accordance with instruction included with that unit.

C. INSTALLING REFRIGERANT LINES

CAUTION

If using existing refrigerant lines make certain that all joints are brazed, not soldered.

Condensing units have provisions for braze connections.

Pressure taps are provided on the service valves of outdoor unit for compressor suction and liquid pressures.

The indoor end of the recommended refrigerant line sets may be straight or with a 90 degree bend, depending upon situation requirements. This should be thoroughly checked out before ordering refrigerant line sets.

Installer's Guide

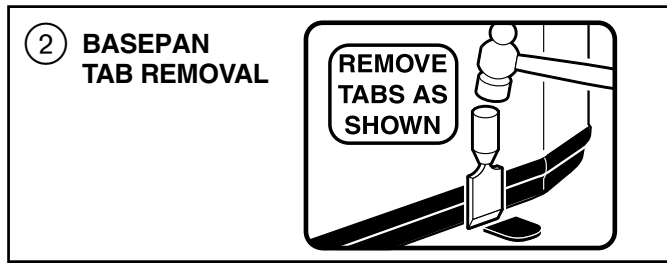

The gas line must always be insulated.

CAUTION

In scroll compressor applications, dome temperatures may be hot. Do not touch top of compressor, may cause minor to severe burning.

The units are factory charged with the system charge required when using fifteen (15) feet of rated connecting line. Unit name-plate charge is with twenty-five (25) feet of line set.

Final refrigerant charge adjustment is necessary. Use the Subcooling Charging procedure in the outdoor unit Service Facts.

1. Determine the most practical way to run the lines.
2. Consider types of bends to be made and space limitations.

NOTE:

Large diameter tubing will be very difficult to rebend once it has been shaped.

3. Determine the best starting point for routing the refrigerant tubing — INSIDE OR OUTSIDE THE STRUCTURE.
4. Provide a pull-thru hole of sufficient size to allow both liquid and gas lines.
5. Be sure the tubing is of sufficient length.
6. Uncoil the tubing — do not kink or dent.
7. Route the tubing making all required bends and properly secure the tubing before making connections.
8. To prevent a noise within the building structure due to vibration transmission from the refrigerant lines, the following precautions should be taken:
 - a. When the refrigerant lines have to be fastened to floor joists or other framing in a structure, use isolation type hangers.
 - b. Isolation hangers should also be used when refrigerant lines are run in stud spaces or enclosed ceilings.
 - c. Where the refrigerant lines run through a wall or sill, they should be insulated and isolated.
 - d. Isolate the lines from all ductwork.

D. SERVICE VALVE OPERATION

BRASS LIQUID AND GAS LINE SERVICE VALVES

The Brass Liquid and Gas Line Service Valves are factory shipped in the seated position to hold factory charge. The pressure tap service port (when depressed) opens only to the field brazing side of the valve when the valve is in the seated position. The liquid line valve is **not** a back seating valve (see **WARNING** below).

WARNING

Extreme caution should be exercised when opening the Liquid Line Service Valve. Turn valve stem counterclockwise only until the stem contacts the rolled edge. (See Figures 3 and 5) No torque is required. Failure to follow this warning will result in abrupt release of system charge and may result in personal injury and/or property damage.

BRASS GAS LINE BALL SERVICE VALVE

The Brass Gas Line Ball Service Valve is shipped in the closed position to hold the factory refrigerant charge. The pressure tap service port (when depressed) opens only to the field brazing side when the valve is in the closed position. The Gas Line Ball Service Valve is full open with a 1/4 turn. See Figure 4.

BRAZING REFRIGERANT LINES

1. Remove lower access cover to access service valves.
2. Before brazing, remove plugs from external copper stub tubes. Clean internal and external surfaces of stub tubes prior to brazing.
3. Cut and fit tubing, minimizing the use of sharp 90° bends.
4. Insulate the entire gas line and its fittings.
5. Do **NOT** allow uninsulated liquid line to come in direct contact with bare gas line.
6. **Precautions should be taken to avoid heat damage to the pressure tap valve core during brazing. It is recommended that the pressure tap port valve core be removed and a wet rag wrapped around the valve body.**

NOTE:

Use care to make sure that no moisture enters pressure tap port, while wet rag is being used.

NOTE:

Precautions should be taken to avoid heat damage to basepan during brazing. It is recommended to keep the flame directly off of the basepan.

7. Use a Dry Nitrogen Purge and Brazing Alloy without flux when brazing the field line to the copper factory connection. Flow dry nitrogen into either valve pressure tap port, thru the tubing and out the other port while brazing.
8. Braze using accepted good brazing techniques.

LEAK CHECK

IMPORTANT:

Replace pressure tap port valve core before attaching hoses for evacuation.

After the brazing operation of refrigerant lines to both the outdoor and indoor unit is completed, the field brazed connections must be checked for leaks. Pressurize through the service valve ports, the indoor unit and field refrigerant lines with dry nitrogen to 350-400 psi. Use soap bubbles or other leak-checking methods to see that all field joints are leak-free! If not, **release pressure**; then repair!

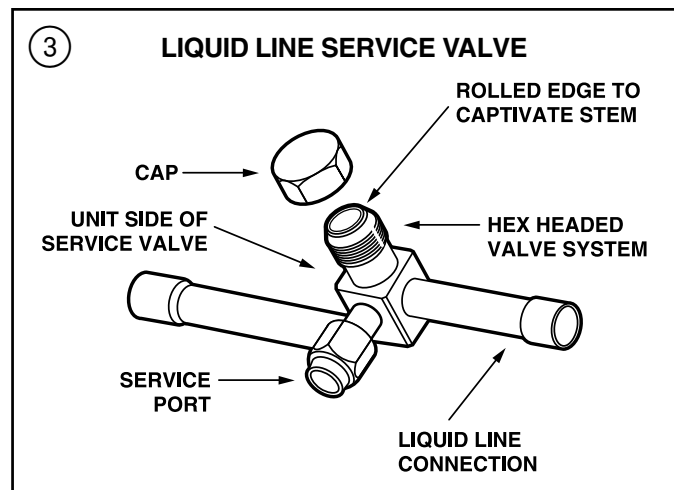

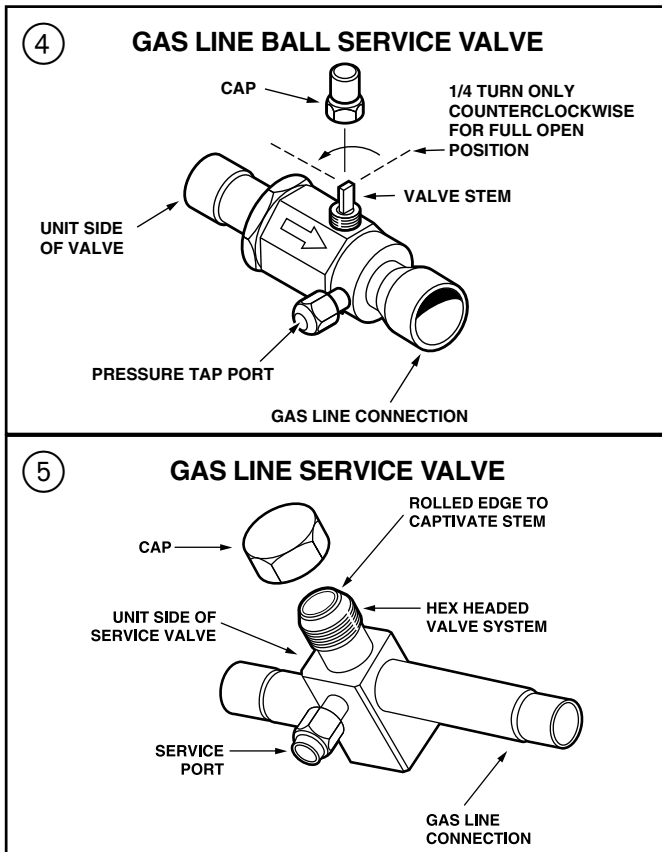

SYSTEM EVACUATION

NOTE:

Since the outdoor unit has a refrigerant charge, the gas and liquid line valves must remain closed.

1. Upon completion of leak check, evacuate the refrigerant lines and indoor coil before opening the gas and liquid line valves.
2. Attach appropriate hoses from manifold gauge to gas and liquid line pressure taps.

NOTE:

Unnecessary switching of hoses can be avoided and complete evacuation of all lines leading to sealed system can be accomplished with manifold center hose and connecting branch hose to a cylinder of HCFC-22 and vacuum pump.

3. Attach center hose of manifold gauges to vacuum pump.
4. Evacuate until the micron gauge reads no higher than 350 microns.
5. Close off valve to vacuum pump and observe the micron gauge. If gauge pressure rises above 500 microns in one (1) minute, then evacuation is incomplete or system has a leak.
6. If vacuum gauge does not rise above 500 microns in one (1) minute, the evacuation should be complete.
7. With vacuum pump and micron gauge blanked off, open valve on HCFC-22 cylinder and charge refrigerant lines and indoor coil with vapor to tank pressure of HCFC-22 supply.
8. Close valve on HCFC-22 supply cylinder. Close valves on manifold gauge set and remove refrigerant charging hoses from liquid and gas pressure tap ports.

NOTE:

A 3/16" Allen wrench is required to open liquid line service valve. A 1/4" Open End or Adjustable wrench is required to open gas line valve. A 3/4" Open End wrench is required to take off the valve stem cap.

9. The liquid line shut-off valve can now be opened. Remove shut-off valve cap. Fully insert hex wrench into the stem and backout counterclockwise until valve stem just touches rolled edge (approximately five [5] turns) observing **WARNING** statement on page 2. See Figure 3.
10. Replace liquid service pressure tap port cap and valve stem cap. These caps **MUST BE REPLACED** to prevent leaks. Replace valve stem cap and pressure tap cap finger tight, then tighten an additional 1/6 turn.
11. The gas valve can now be opened. Open the gas valve by removing the shut-off valve cap and turning the valve stem 1/4 turn counterclockwise, using 1/4" Open End or Adjustable wrench. See Figure 4.
12. The gas valve is now open for refrigerant flow. Replace valve stem cap to prevent leaks. Again, these caps **MUST BE REPLACED** to prevent leaks. Replace valve stem cap and pressure tap cap finger tight, then tighten an additional 1/6 turn. See Figure 4.

If refrigerant lines are longer than fifteen (15) feet and/or a different size than recommended, it will be necessary to adjust system refrigerant charge upon completion of installation. See the unit Service Facts.

E. ELECTRICAL CONNECTIONS

⚠ WARNING

When installing or servicing this equipment, ALWAYS exercise basic safety precautions to avoid the possibility of electric shock.

1. Power wiring and grounding of equipment must comply with local codes.
2. Power supply must agree with equipment nameplate.
3. Install a separate disconnect switch at the outdoor unit.
4. Ground the outdoor unit per local code requirements.
5. Provide flexible electrical conduit whenever vibration transmission may create a noise problem within the structure.
6. The use of color coded low voltage wire is recommended to simplify connections between the outdoor unit, the ComfortLink™ II control and the indoor unit.

Table 1 – NEC Class II Control Wiring

ComfortLink™ II Control Wiring	
WIRE SIZE	MAX. WIRE LENGTH
18 AWG	250 FT

NOTE:

The maximum total cable length for the entire Comfort Control communicating system is 500 ft. 18 AWG.

7. Mount the ComfortLink™ II control in accordance with instruction included with the ComfortLink™ II control. Wire per appropriate hook-up diagram (included in these instructions).

F. COMPRESSOR START-UP

After all electrical wiring is complete, SET THE COMFORTLINK™ II CONTROL SWITCH IN THE OFF POSITION SO COMPRESSOR WILL NOT RUN, and apply power by closing the system main disconnect switch. This will activate the compressor sump heat (where used). Do not change the ComfortLink™ II control switch until power has been applied for one (1) hour. Following this procedure will prevent potential compressor overload trip at the initial start-up.

Installer's Guide

G. OPERATIONAL AND CHECKOUT PROCEDURES

Final phases of this installation are the unit Operational and Checkout Procedures which are found in this instruction (see page 7). To obtain proper performance, all units must be operated and charge adjustments made in accordance with procedures found in the Service Facts.

IMPORTANT:

Perform a final unit inspection to be sure that factory tubing has not shifted during shipment. Adjust tubing if necessary so tubes do not rub against each other when the unit runs. Also be sure that wiring connections are tight and wire routing is secure.

H. SEACOAST SHIELD

Units installed within one (1) mile of salt water, including seacoasts and inland waterways, require the addition of BAYSEAC001 (Seacoast Kit) at the time of installation.

IMPORTANT:

See Limited Warranty information in Use and Care Manual.

I. TROUBLESHOOTING TROUBLESHOOTING CHART — WHAT TO CHECK

SYSTEM FAULTS	HIGH VOLTAGE WIRING	POWER SUPPLY	WIRING	CONDENSER	SPLIT CAPACITOR	STARTER	CONTACTOR CONTACTS	CONTROL WIRING	CONTROL BOARD	LOW VOLTAGE WIRING	STATOR WINDING	REFRIG. COMPRESSOR	REFRIG. CONDENSER	REFRIG. LIQUOR	REFRIG. TUBING	REFRIG. OIL LEVEL	EXCESSIVE OIL	RESTRICTED OIL FLOW	RESTRICTED OIL FLOW	RESTRICTED OIL FLOW	RESTRICTED OIL FLOW	RESTRICTED OIL FLOW	RESTRICTED OIL FLOW	RESTRICTED OIL FLOW	RESTRICTED OIL FLOW	RESTRICTED OIL FLOW	RESTRICTED OIL FLOW						
Liquid Pressure Too High																					P	P	P	P	S			S	S				
Liquid Pressure Too Low															S	P												S	S	S			
Suction Pressure Too High																					S	P	P					S	P				
Suction Pressure Too Low																							S							S	P	S	
Liquid Refrig. Floodback TXV System																														S	S		
I.D. Coil Frosting																								P							P	S	
Compressor Runs Inadequate or No Cooling																									S	P	P	S			S	P	S
ELECTRICAL																																	
Compressor & O.D. Fan Do Not Start	P	P										S	P	P	P																		
Compressor Will Not Start But O.D. Fan Runs	P	S	P	P	P								S																				
O.D. Fan Won't Start	P	P																															
Compressor Hums But Won't Start	P		P	P	P	P	S						S																				
Compressor Cycles on IOL	P	S	P	P	P	P	S						P	S	P	S	S	S	S											S	S		
I.D. Blower Won't Start	P	S														S	P	P															

P - Primary Causes S - Secondary Causes

⑥

FIELD WIRING DIAGRAM COMMUNICATING INDOOR UNIT – COMMUNICATING OUTDOOR UNIT

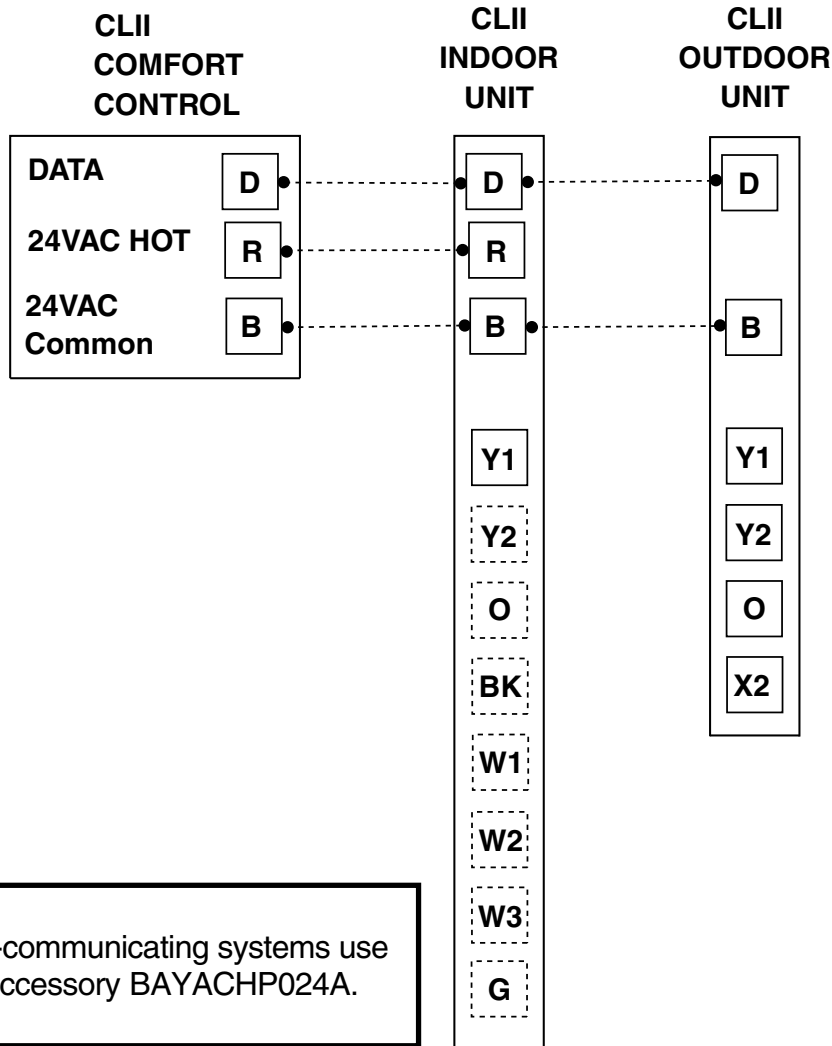

NOTE: For non-communicating systems use 24-volt harness accessory BAYACHP024A.

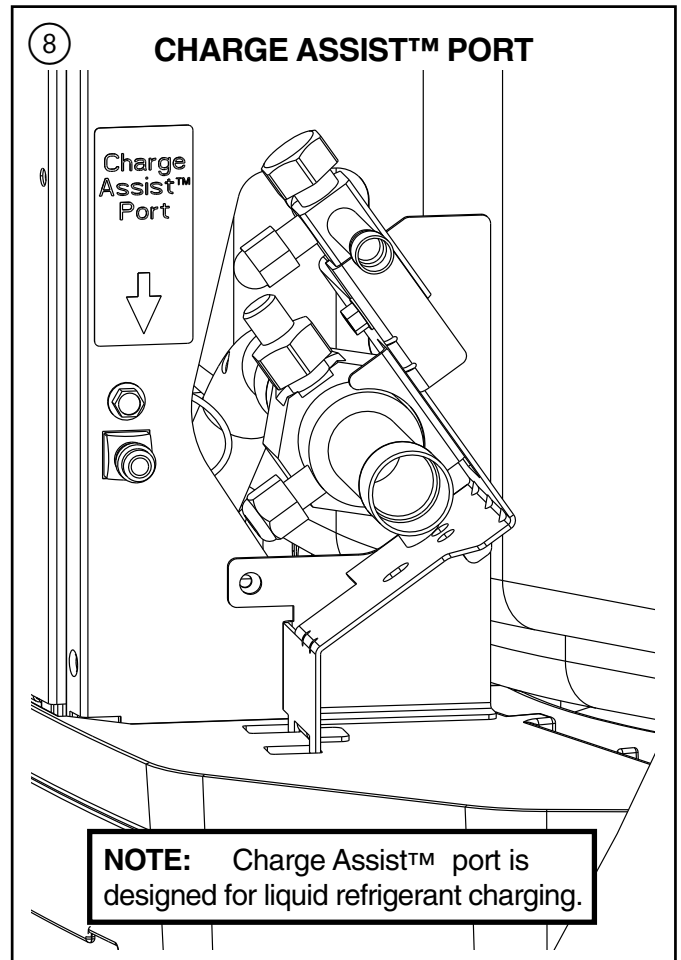
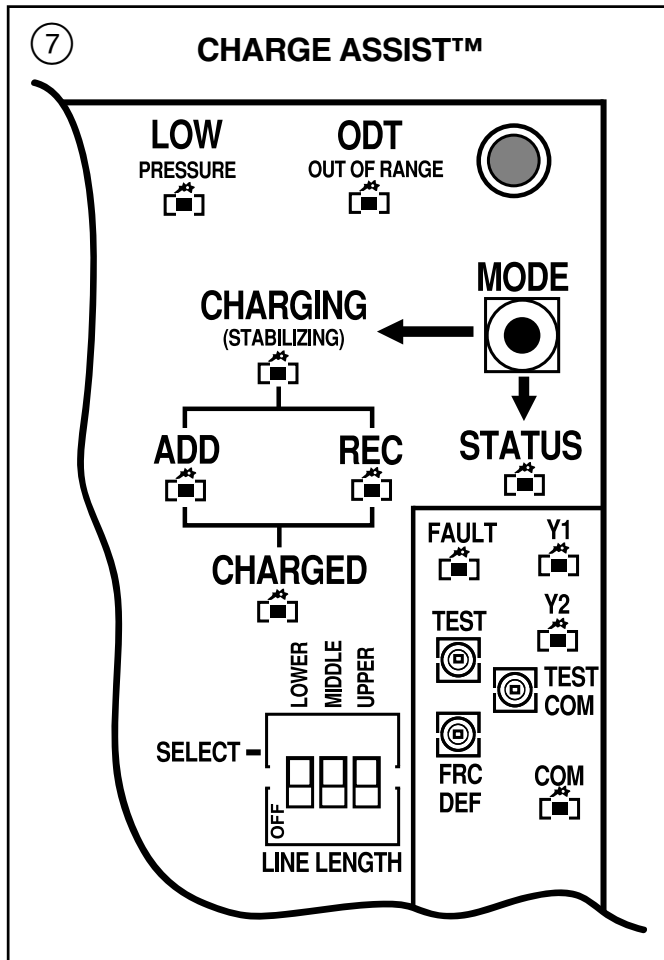

DIRECTION FOR CHARGE ASSIST™

NOTE: Outdoor Temperature (ODT) must be between 65°F and 100°F.

Be sure to set Dip Switches for Line Length and Lift before entering Charge Assist™ Mode. (See Subcool Charging Table Corrections for Line Length and Rise in Service Facts shipped with the outdoor unit.)

To enter Charge Assist™ Mode, press the MODE button for at least one (1) second. The on-board LEDs will indicate if the system is capable of continuing. For a detailed description of on-board LEDs and their function, see the Charge Assist™ Procedure (18-AC72D1-*) contained in the Outdoor Unit (the position of the * denotes the latest revision number).

The system will take approximately 12-20 minutes to stabilize before the charge can be checked by Charge Assist™. Once the system is stabilized, watch to see which LED turns on next. If the system charge is correct, the "CHARGED" LED will turn on and remain on for one (1)

hour. Once charged, the system will exit Charge Assist™ and control will return to the Comfort Control.

If the system charge is low, the "ADD" LED will turn on and stay on up to one (1) hour or until enough refrigerant is added to reach the required system charge level and turn on the "CHARGED" LED.

When the "ADD" LED is on, the charging solenoid output will be active. This feature works to automatically control refrigerant flow with BAYCAKT001.

If the system charge is high, the "REC" LED will turn on and the unit will exit Charge Assist™. You must recover refrigerant from the system before re-entering Charge Assist™.

For instructions on the Charge Assist™ tool BAYCAKT001, see the Installer's Guide 18-HH15D1-* (the position of the * denotes the latest revision number).

For additional information on manual charging, please see the Service Facts shipped with the outdoor unit.

Installer's Guide

2TTZ9 OUTLINE DRAWING

NOTE: ALL DIMENSIONS ARE IN MM (INCHES).

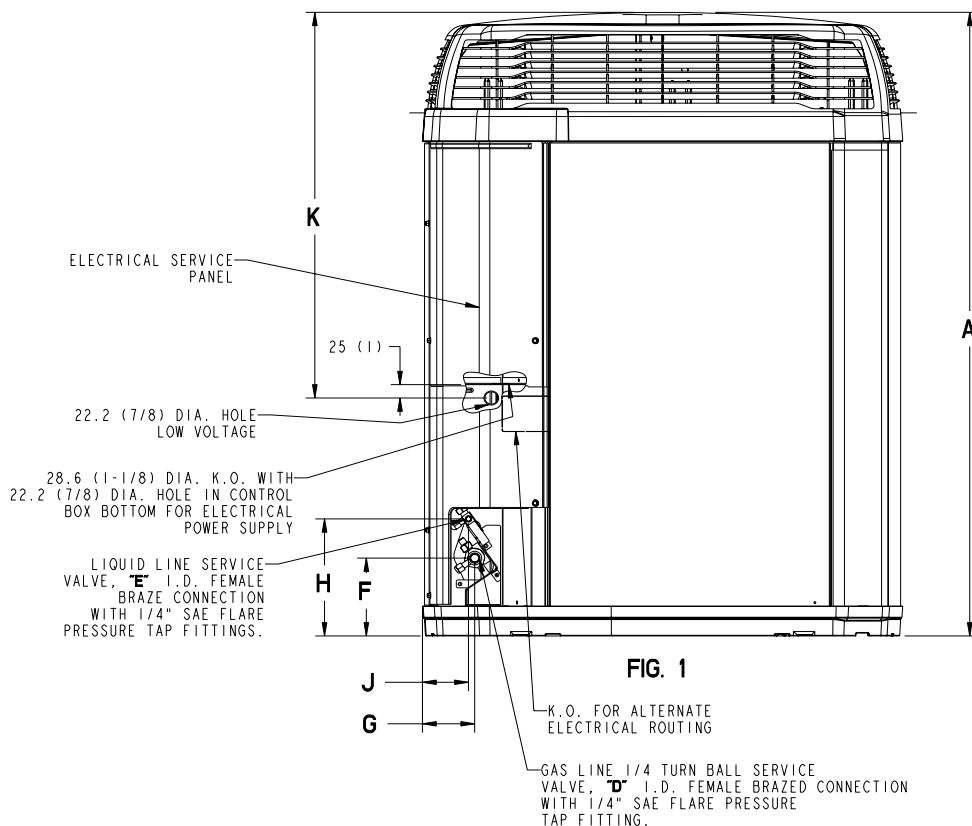
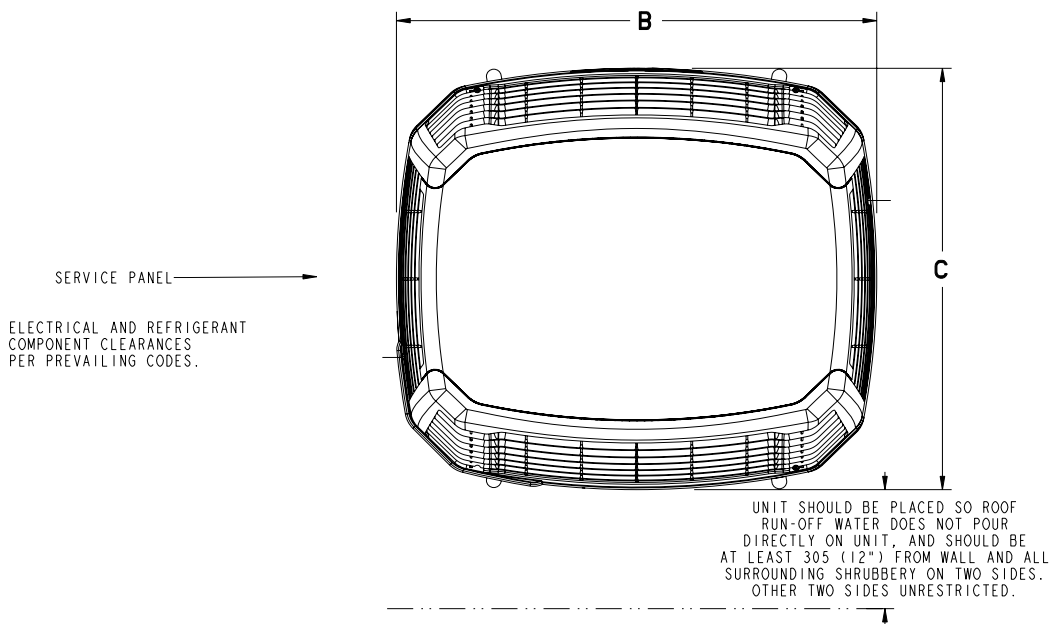

MODELS	BASE	FIG.	A	B	C	D	E	F	G	H	J	K
2TTZ9030C	4	1	1267 (49-7/8)	946 (37-1/4)	870 (34-1/4)	7/8	3/8	152 (6)	98 (3-7/8)	219 (8-5/8)	86 (3-3/8)	933 (36-3/4)
2TTZ9036C	4	1	1267 (49-7/8)	946 (37-1/4)	870 (34-1/4)	7/8	3/8	152 (6)	98 (3-7/8)	219 (8-5/8)	86 (3-3/8)	933 (36-3/4)
2TTZ9048C	4	1	1267 (49-7/8)	946 (37-1/4)	870 (34-1/4)	1-1/8	3/8	152 (6)	98 (3-7/8)	219 (8-5/8)	86 (3-3/8)	933 (36-3/4)
2TTZ9060C	4	1	1267 (49-7/8)	946 (37-1/4)	870 (34-1/4)	1-1/8	3/8	152 (6)	98 (3-7/8)	219 (8-5/8)	86 (3-3/8)	933 (36-3/4)

From Dwg. 21D152635 Rev. 14

MOUNTING HOLE LOCATION

Note: All dimensions are in MM (Inches).

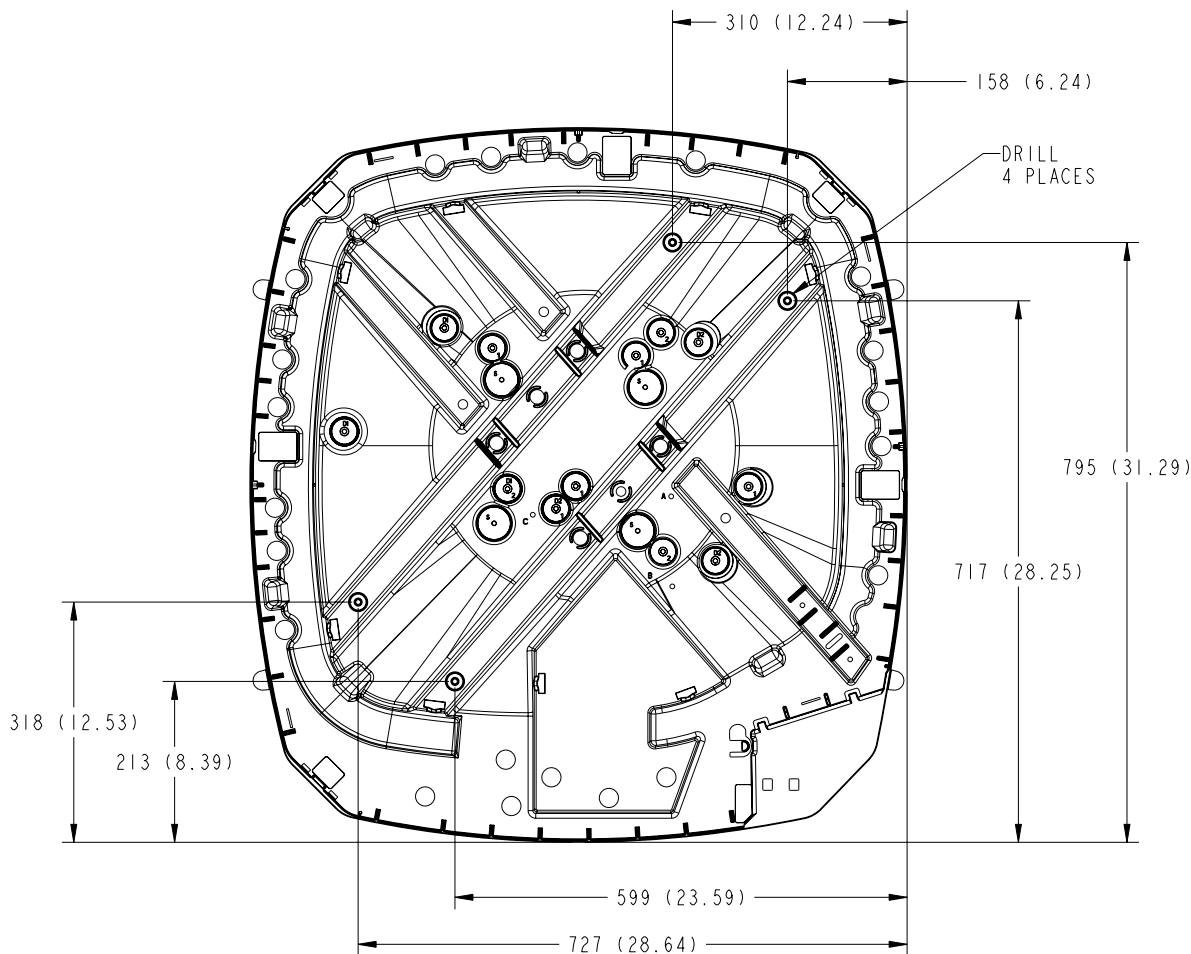

BASE 4

From Dwg. D152637 Rev. 2

CHECKOUT PROCEDURE

After installation has been completed, it is recommended that the entire system be checked against the following list:

- | | | | |
|--|-----|---|-----|
| 1. Refrigerant Line, Leak checked | [] | 8. Supply registers and return grilles open and unobstructed | [] |
| 2. Suction Lines and Fittings properly insulated | [] | 9. Return air filter installed | [] |
| 3. Have all Refrigerant Lines been secured and isolated properly? | [] | 10. ComfortLink™ II control is accurate. Check against a reliable thermometer. Adjust per instructions with ComfortLink™ II control | [] |
| 4. Have passages through masonry been sealed? If mortar is used, prevent mortar from coming into direct contact with copper tubing | [] | 11. Is correct speed tap being used? (Indoor blower motor) | [] |
| 5. Verify tightness of all electrical connects | [] | 12. Operate complete system in each mode to insure safe operation. | [] |
| 6. Observe outdoor fan during on cycle for clearance and smooth operation | [] | | |
| 7. Indoor coil drain line drains freely. Pour water into drain pan | [] | | |



Trane
www.trane.com



ARI Standard[™]
210/240 UAC

Trane has a policy of continuous product and product data improvement and it reserves the right to change design and specifications without notice.