

INSTALLATION OPERATION MAINTENANCE

WCP-IOM-1E
18-BB33D9-6

Library	Service Literature
Product Section	Unitary
Product	Packaged Heat Pump
Model	WCP
Literature Type	Installation, Operation, Maintenance
Sequence	1E
Date	December 2003
File No.	SV-UN-PKGP-WCP-IOM-1E 12/03
Supersedes	New

ALL phases of this installation must comply with
NATIONAL, STATE AND LOCAL CODES

Model:

WCP036F1,3,4
WCP048F1,3,4
WCP060F1,3,4

BAYLIFT002AA
LIFTING LUG KIT

Single Package Heat Pump 12 SEER Convertible 3, 4, 5 Ton

IMPORTANT—This Document is customer property and is to remain with this unit. Please return to service information pack upon completion of work.

⚠ WARNING: HAZARDOUS VOLTAGE - DISCONNECT POWER BEFORE SERVICING

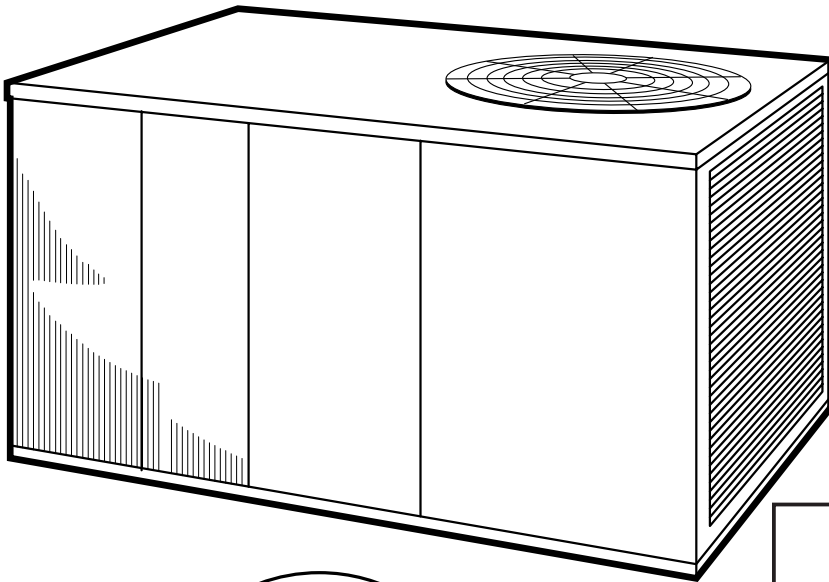

All phases of this installation must comply with the **NATIONAL, STATE & LOCAL CODES**. In the absence of local codes, the installation must conform with **National Electric Code -- ANSI/NFPA 70** or "**LATEST REVISION**."

Since American Standard has a policy of continuous product and product data improvement, it reserves the right to change design and specification without notice.

© 2004 American Standard Inc. All rights reserved

NOTICE

Warnings and Cautions appear at appropriate locations throughout this manual.
Read these carefully.

⚠ WARNING: Indicates a potentially hazardous situation which, if not avoided, could result in death or serious injury.

⚠ CAUTION: Indicates a potentially hazardous situation which, if not avoided, may result in minor or moderate injury. It may also be used to alert against unsafe practices and where property-damage-only accidents could occur.

01/04

GENERAL INFORMATION

IMPORTANT: Read this entire manual before beginning installation procedures.

SAFETY NOTICE. THIS INFORMATION IS INTENDED FOR USE BY INDIVIDUALS POSSESSING ADEQUATE BACKGROUNDS OF ELECTRICAL AND MECHANICAL EXPERIENCE. ANY ATTEMPT TO REPAIR A CENTRAL AIR CONDITIONING PRODUCT MAY RESULT IN PERSONAL INJURY AND/OR PROPERTY DAMAGE. THE MANUFACTURER OR SELLER CANNOT BE RESPONSIBLE FOR THE INTERPRETATION OF THIS INFORMATION, NOR CAN IT ASSUME LIABILITY IN CONNECTION WITH ITS USE.

⚠ WARNING: HAZARDOUS VOLTAGE - DISCONNECT POWER BEFORE SERVICING

IMPORTANT: RECONNECT ALL GROUNDING DEVICES. ALL PARTS OF THIS PRODUCT CAPABLE OF CONDUCTING ELECTRICAL CURRENT ARE GROUNDED. IF GROUNDING WIRES, SCREWS, STRAPS, CLIPS NUTS OR WASHERS USED TO COMPLETE A PATH TO GROUND ARE REMOVED FOR SERVICE. THEY MUST BE RETURNED TO THEIR ORIGINAL POSITION AND PROPERLY FASTENED.

IMPORTANT: ALL POWER LEGS MAY NOT BE BROKEN BY CONTACTORS. SEE WIRING DIAGRAM ON UNIT CONTROL BOX COVER. BEFORE STARTING THE COMPRESSOR, THE CRANKCASE HEATER SHOULD BE ENERGIZED FOR EIGHT HOURS.

Read this manual carefully before attempting to install, operate, or perform maintenance on this unit. Installation and maintenance should be performed by qualified service technicians only.

NOTE: "Warnings" and "Cautions" appear at appropriate places in this manual. Your personal safety and the proper operation of this air conditioning product require that you follow them carefully. The manufacturer assumes no liability for installations or servicing performed by unqualified personnel.

INSPECTION

1. Check for damage after the unit is unloaded. Report promptly, to the carrier, any damage found to the unit. Do not drop the unit.

IMPORTANT: The use of "spreader bars" is required when hoisting the unit (to prevent damage to sides and top).

2. Check the unit's nameplate to determine if the unit is correct for the intended application. The power supply must be adequate for both the unit and all accessories.

3. Check to be sure the refrigerant charge has been retained during shipment. Access to 1/4" flare pressure taps may be gained by removing the furnace compartment access panel.

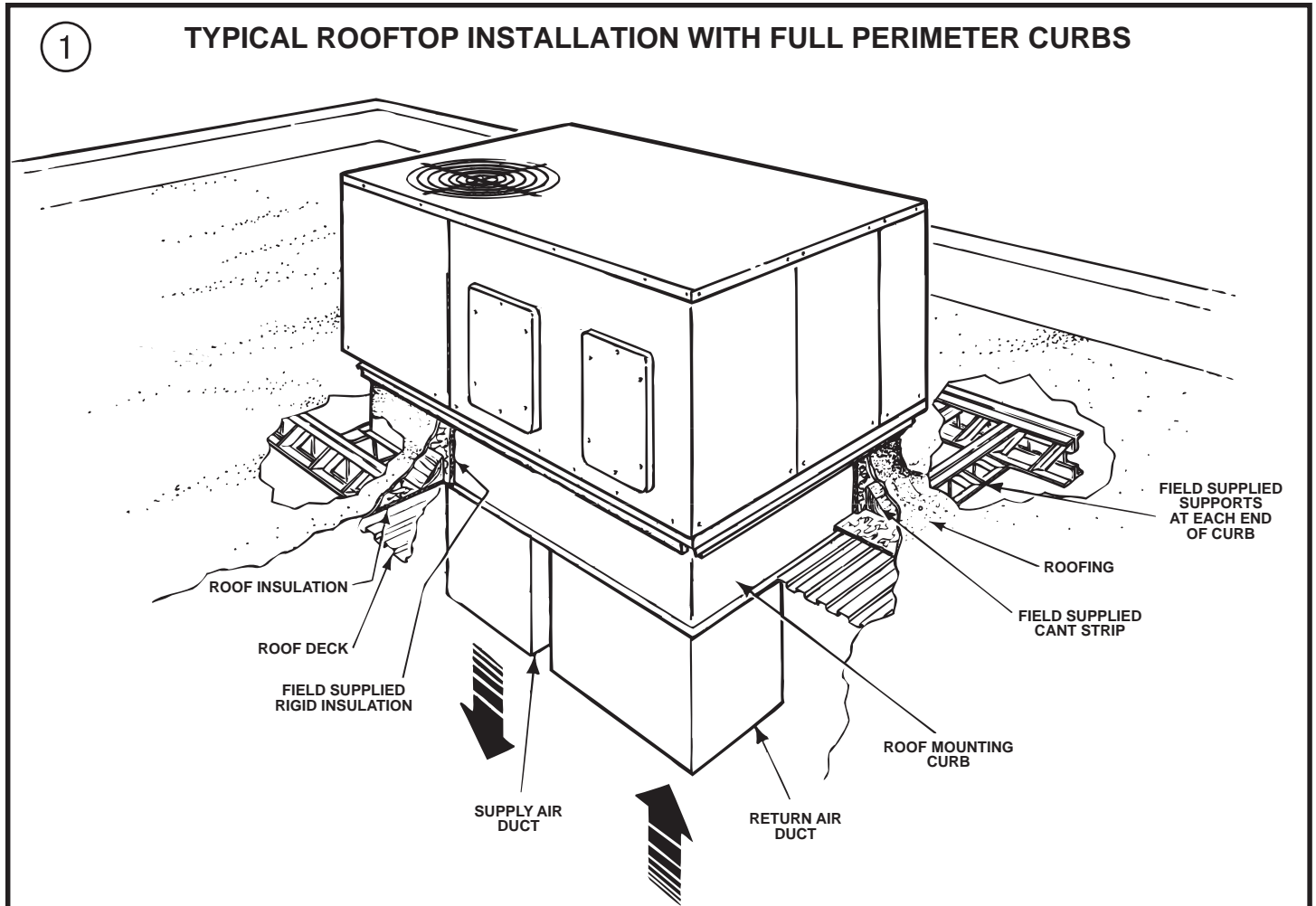

2

TYPICAL ROOFTOP INSTALLATION WITH BAYCURB030A,038A

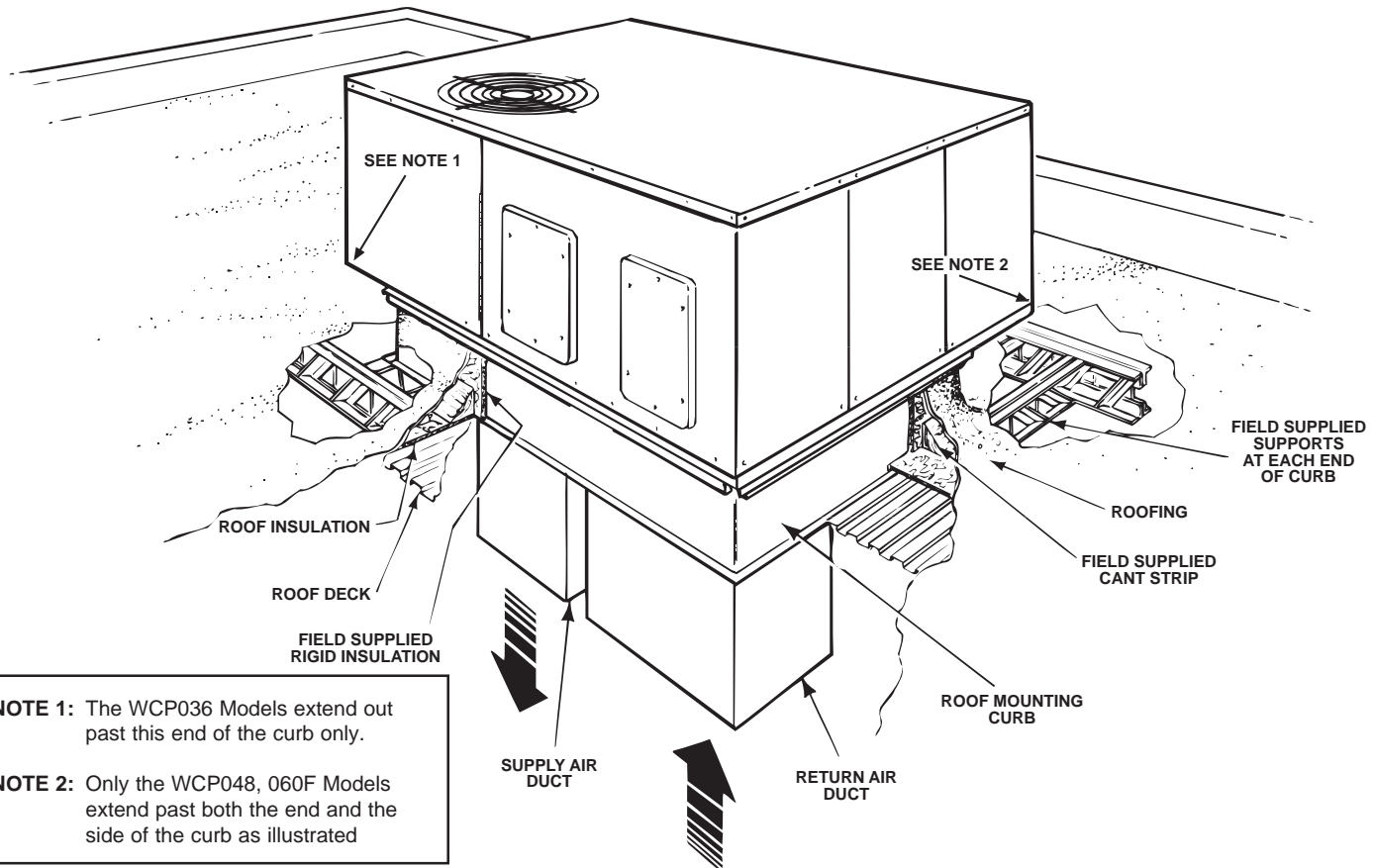

NOTE 1: The WCP036 Models extend out past this end of the curb only.

NOTE 2: Only the WCP048, 060F Models extend past both the end and the side of the curb as illustrated

3

CONVERTING HORIZONTAL TO DOWNFLOW

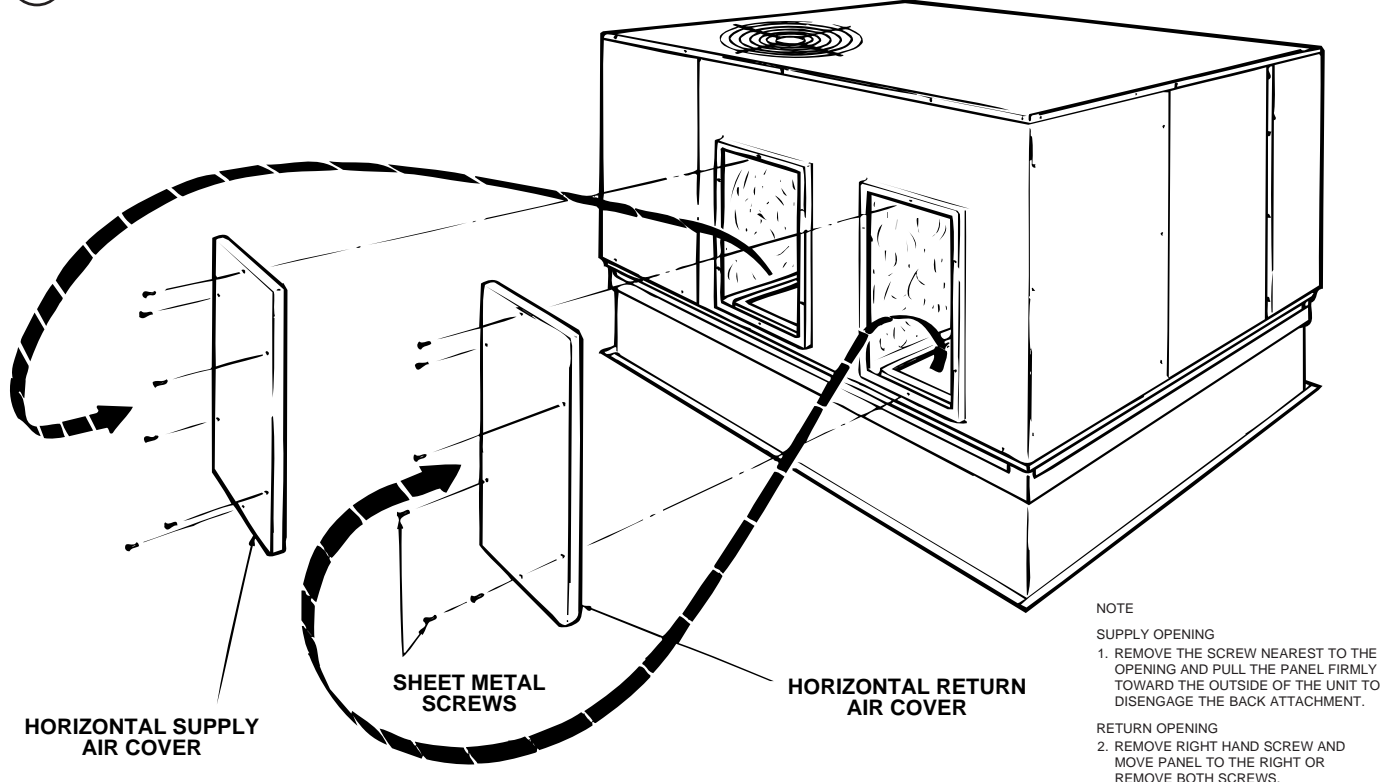

NOTE

SUPPLY OPENING

1. REMOVE THE SCREW NEAREST TO THE OPENING AND PULL THE PANEL FIRMLY TOWARD THE OUTSIDE OF THE UNIT TO DISENGAGE THE BACK ATTACHMENT.

RETURN OPENING

2. REMOVE RIGHT HAND SCREW AND MOVE PANEL TO THE RIGHT OR REMOVE BOTH SCREWS.

DIMENSIONAL DATA

4

WCP036-060F OUTLINE - BACK

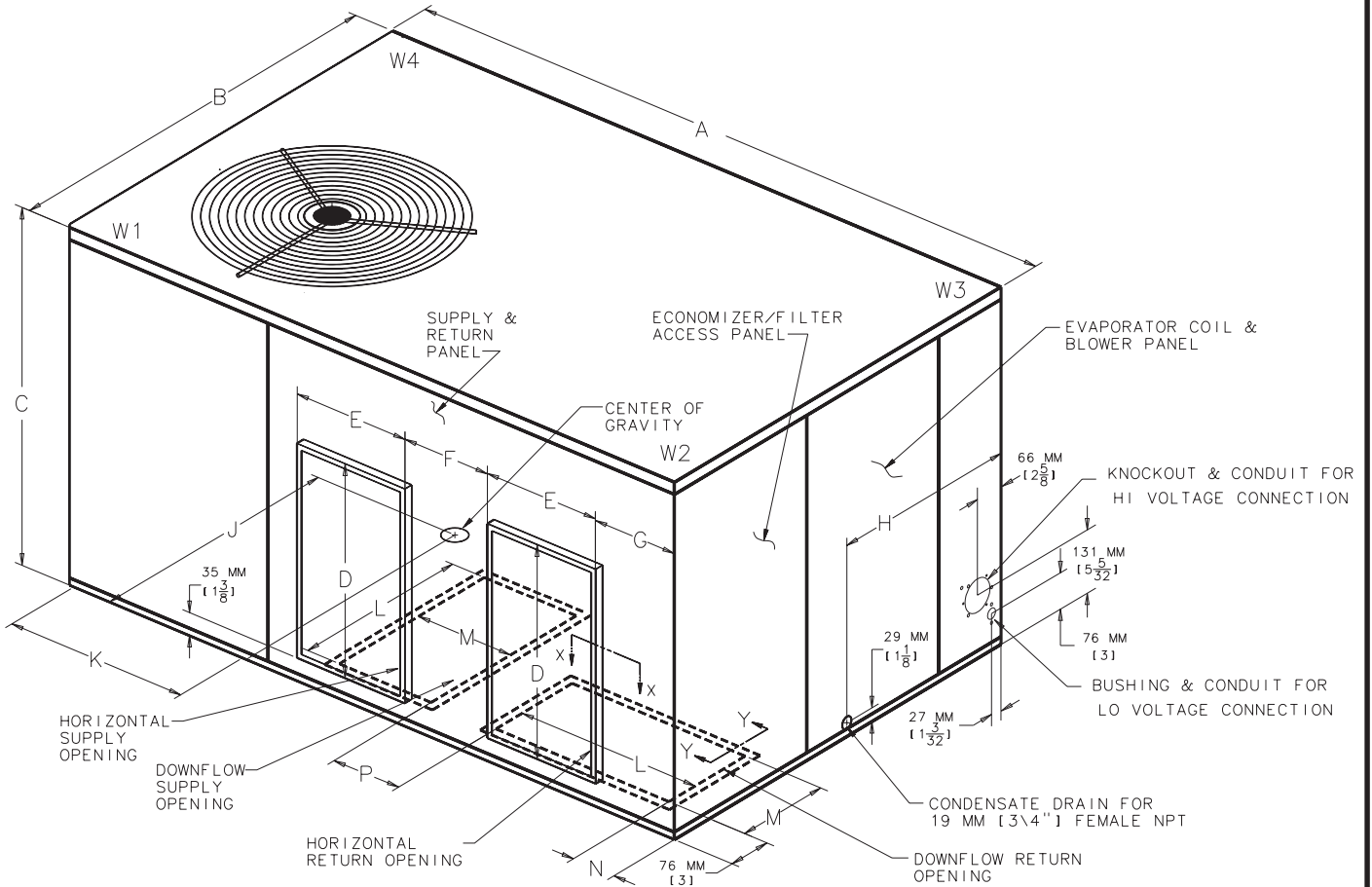

D668482

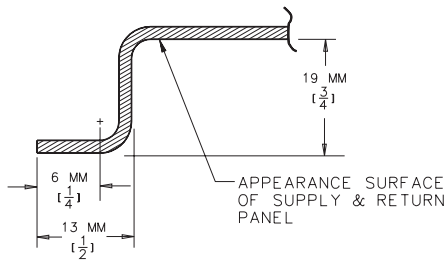

SECT. X-X

TYPICAL CROSS SECTION OF SUPPLY & RETURN PERIMETER FLANGES

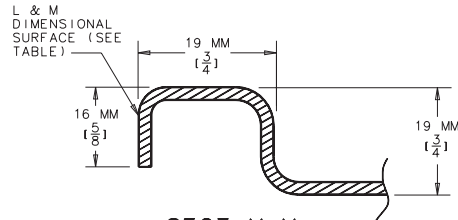

SECT Y-Y

TYPICAL CROSS SECTION OF DOWNFLOW SUPPLY & RETURN PERIMETER FLANGES

MODEL	CORNER WEIGHT (LBS)				UNIT WEIGHT	A	B	C	D	E	F	G	H	J	K	L	M	N	P
	W1	W2	W3	W4															
WCP036F	110	82	88	118	398	62-7/8	36	29-3/16	18-9/16	11-1/16	6-9/16	11-1/8	17	19-1/4	27-1/2	17-1/2	10	3	8-3/4
WCP048F	149	104	117	134	504	64-3/8	45	33-1/8	21-1/16	15-1/16	4-15/16	9-1/8	21-15/16	24-1/4	28-1/2	20	14	3-1/2	8-5/16
WCP060F	149	104	117	134	504									24-1/4	28-1/2				

DIMENSIONAL DATA

5

WCP036-060F OUTLINE - FRONT

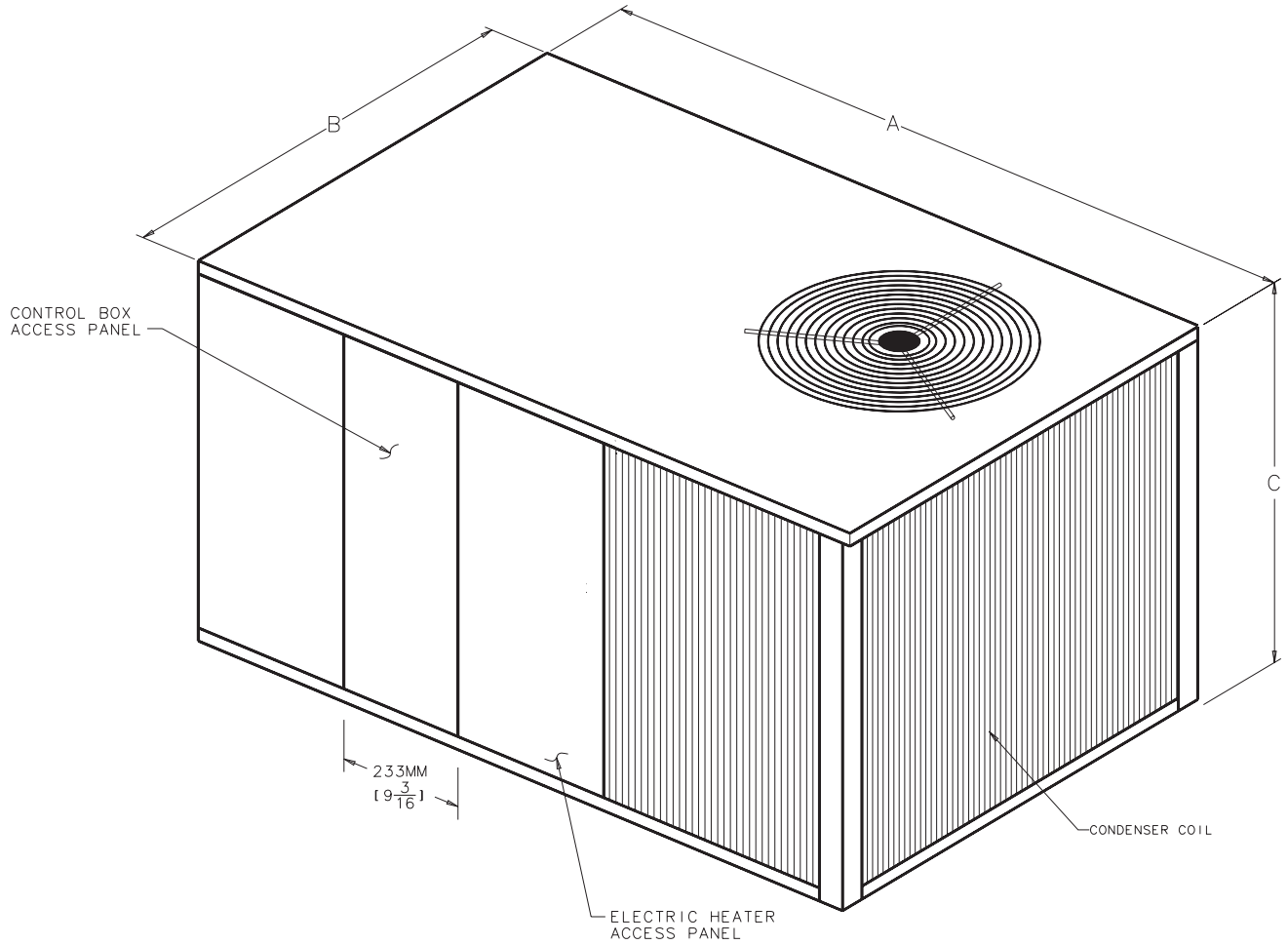

D668483

RECOMMENDED SERVICE CLEARANCE	
BACK	* 6.0"
LEFT SIDE	30.0"
RIGHT SIDE	24.0"
FRONT	42.0"

* 18" WITH FRESH AIR ACCESSORY
 * 30" WITH ECONOMIZER

CLEARANCE TO COMBUSTIBLE MATERIAL	
BOTTOM	0.0"
BACK	1.0"
LEFT SIDE	6.0"
RIGHT SIDE	6.0"
FRONT SIDE	12.0"
TOP	36.0"

MODEL	A	B	C
WCP036F	62-7/8	36	29-3/16
WCP048F WCP060F	64-3/8	45	33-3/8

REQUIRED CLEARANCE FOR UNIT INSTALLATION AND ROOF PENETRATION HOLE SIZE REQUIRED

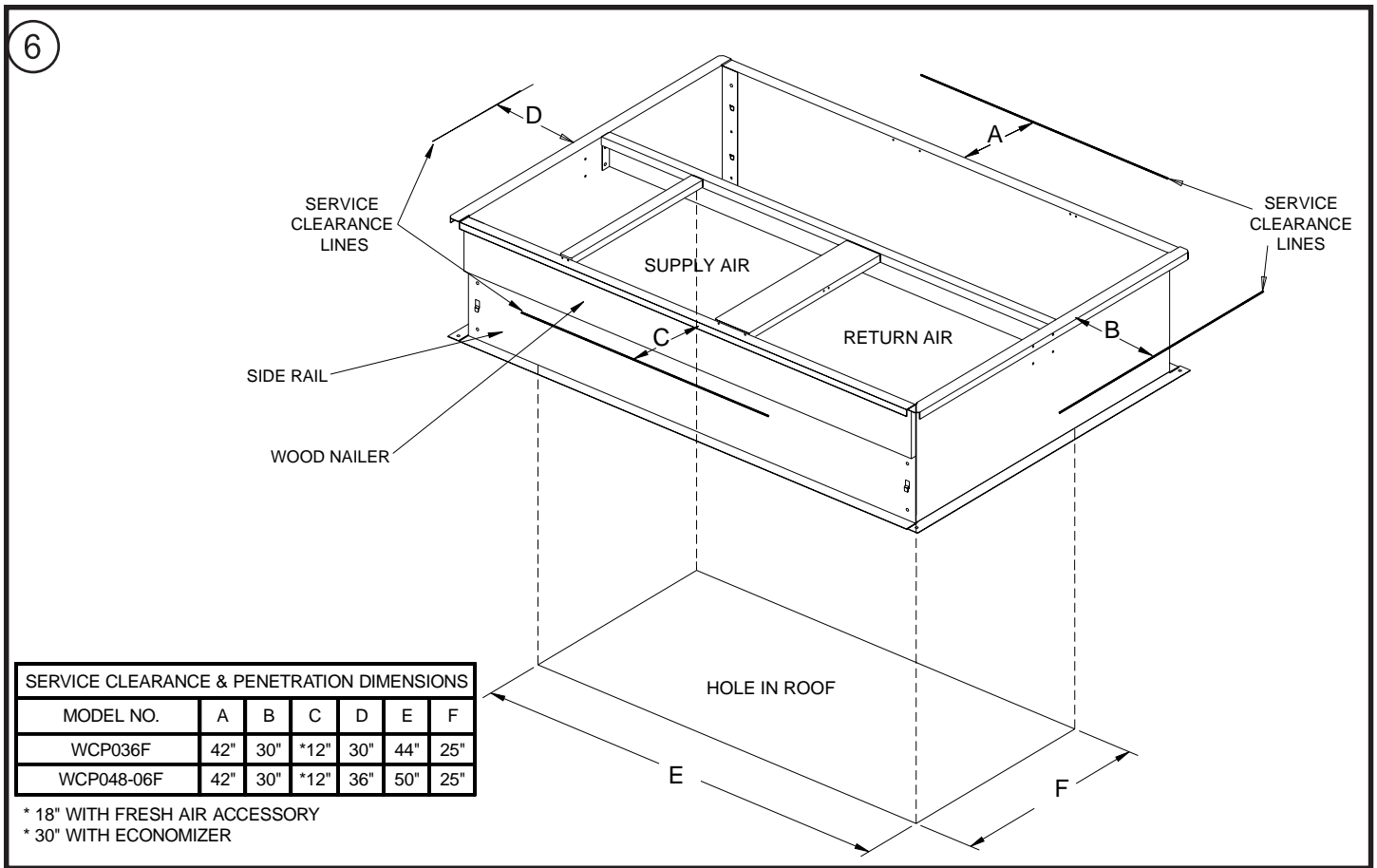

LOCATIONS AND RECOMMENDATIONS

These units are designed for outdoor installation. For proper installation, the following recommendations must be considered.

NOTE: Unit shipped for horizontal installation. Convert to downflow per instruction.

The discharge air from the condenser fans must be unrestricted for a minimum of 3 feet above the unit.

Roof Mounting Curb (field assembled BAYCURB030A,038A and BAYCURB033A, BAYCURB034A) or a field fabricated curb must be in place before unit is hoisted to the roof.

Roof Mounting Curb (frame) must be installed on a flat, level section of the roof (max. of 1/4" per foot pitch), providing a level mounting surface for the unit. In addition, provide sufficient height above the roof to prevent water from entering unit.

In locations where deep snows are encountered, RAISE THE UNIT A MINIMUM OF 12" OFF THE ROOF, DECK OR SLAB—the chance of the coil being blocked with snow will be reduced. The water that occurs during the defrost has a better chance of flowing from the vicinity of the unit.

Roof Mounting Curb used with WCP—F models is approximately 14" high. This is normally sufficient height to prevent snow blockage and additional clearance is not necessary.

AVOID LOCATING THE UNIT WHERE SNOW TENDS TO DRIFT. This will reduce the times when it is necessary for the customer to remove the snow from around the unit. MAKE CERTAIN THE CUSTOMER KNOWS THAT SNOW ACCUMULATIONS SHOULD BE REMOVED FROM THE SIDES OF THE UNIT FOR BEST EFFICIENCY.

A snow drift barrier may be installed around the unit to prevent a build up of snow on the sides of the unit. The barrier should be of sufficient distance from the unit to prevent restriction of airflow to and from unit.

LOCATE THE UNIT SO THAT THE WATER VAPOR THAT DISCHARGES UPWARD DURING DEFROST DOES NOT CONDENSE ON WINDOWS AND FOG THEM OR CAUSE ICICLES TO FORM ON OVERHANGS.

1. Be sure the mounting curb spans structural members (trusses) of the roof, thereby providing sufficient support for weight of the unit, curb and duct(s) plus any accessories (factory or field installed). See Figures 1, 2, 3, 4, 5, 6, 7, 8, 9, 10, 11 and 12.

NOTE: If any internal accessories are to be added to the unit it should be done at the shop if at all practical.

2. Unit should be positioned so Roof-Run-Off water does not pour directly on unit.

3. For “Roof Top Application,” unit must be elevated above roof with a mounting Curb or Frame.
4. Exhaust vents or other sources of contaminated air should not be near unit air inlet if outside air is to be introduced as a make-up air or the economizer ventilation feature is to be used.
5. Check the handling facilities to insure the safety of personnel and the unit(s).
6. CAUTION MUST BE TAKEN AT ALL TIMES TO AVOID PERSONAL INJURIES AND/OR DAMAGE TO EQUIPMENT.
7. The unit must be mounted level for proper drainage of defrost water through the holes in the base pan.
8. Flexible duct connectors must be of a flame retardant material. All duct work outside of the structure must be insulated and weatherproofed in accordance with local codes.
9. Roof flashing must be installed to seal the roof curb cavity and must conform to local building codes.
10. Holes through exterior walls must be sealed in accordance with local codes.

11. Access and service clearances for the unit must be given careful consideration when locating the duct entrance openings. Figures 4 and 5 provide unit dimensions.
12. All fabricated outdoor ducts should be as short as possible.
13. Be sure the hole in the structure for the ducts is large enough to accommodate the fabricated ducts and the insulation surrounding them. (See Figure 6.)

CLEARANCES

1. The recommended clearances for single-unit installations are illustrated in Figures 5 and 6. These minimum requirements are not only an important consideration when determining unit placement, but they are also essential to ensure adequate serviceability, maximum capacity, and peak operating efficiency.
2. Any reduction of the unit clearances indicated in this illustration may result in condenser coil starvation, or the recirculation of warm condenser air. Actual clearances which appear to be inadequate should be reviewed with a local sales engineer.

IMPORTANT!: To convert to downflow remove covers from the downflow supply and return air openings and place them over the horizontal supply and return air openings (painted side out) and secure with sheet metal screws.

INSTALLATION

UNIT SUPPORT

If unit is to be roof mounted, check building codes for weight distribution requirements. Refer to accessory roof curb mounting instructions. Check unit nameplate for supply voltage required. Determine if adequate electrical power is available. Refer to specification sheet.

LOCATION AND CLEARANCES

Installation of the unit should conform to local building codes or, in the absence of local codes, to the ANSI/NFPA No. 70-1987 National Electrical Code or “Latest Revision.” Canadian installations must conform to CSA and local codes.

Select a location that will permit unobstructed airflow into the condenser coil and away from the fan discharge and permit unobstructed service access into the compressor compartment. Suggested airflow clearances and service clearances are given in Figure 5.

PLACING AND RIGGING

1. Before preparing the unit for lifting, check the outline drawing for center of gravity for lifting safety. Because of placement of internal components, the unit weight may be unevenly distributed. Approximate unit weights are given in outline drawing on page 3.

NOTE: Accessory BAYLIFT002M Four (A) lifting lugs are recommended for rigging the unit for hoisting. See Figure 7 insert “B”.

2. Insert the four lifting lugs in openings provided in drip lip on perimeter of unit. See Figure 7 insert “B”.
3. Before hoisting the unit, be sure that the proper method of rigging is used, with straps or slings and spreader bars for protection during lifting.

IMPORTANT!: DO NOT LIFT THE UNIT WITHOUT TEST-LIFTING FOR BALANCE AND RIGGING. DO NOT LIFT THE UNIT IN WINDY CONDITIONS OR ABOVE PERSONNEL. DO NOT LIFT THE UNIT BY ATTACHING A CLEVIS, HOOKS, PINS OR BOLTS TO THE UNIT CASING, CASING HARDWARE, ANGLES, TABS OR FLANGES. FAILURE TO OBSERVE THESE WARNINGS MAY RESULT IN EQUIPMENT DAMAGE.

4. When the curb and air ducts have been properly installed, the unit is ready to be hoisted to the roof and set in position.

IMPORTANT!: “Spreader Bars” must be used when hoisting unit.

5. **IMPORTANT: The unit must be lowered into position P.V.C. rubber tape on the curb flange permits the unit to be repositioned if required without destroying the P.V.C. rubber seals affixed to mounting curb.**
6. **PLACING UNIT ON MOUNTING CURB**—The unit is designed with a perimeter drip lip that is lower than the unit base pan, see Figure 7 insert “A”.
7. Position the unit drip lip down over and in contact with the outside corner of the curb, as illustrated in Figure 7 insert “A”. Continue to lower unit on top of curb, with the unit drip lip astraddle and in contact with both the end and side rail of curb, the unit is now resting on top of curb.
8. Take the two (2) hold down brackets shipped with curb and secure unit to curb with hold down brackets as illustrated in Figure 8 insert “A”.

7

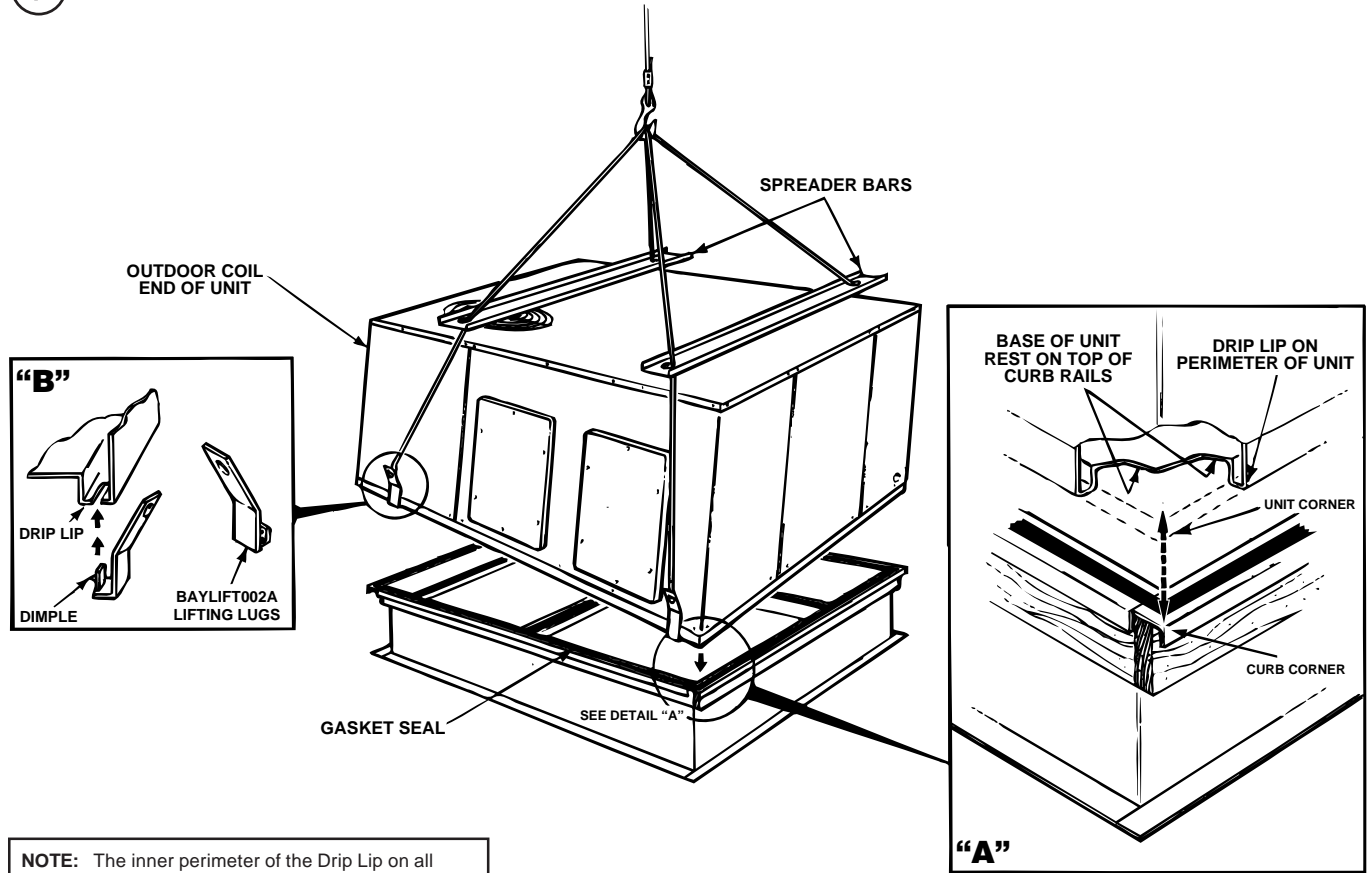

NOTE: The inner perimeter of the Drip Lip on all units should be flush with the outer perimeter of the curb on the two sides shown here. See Figure 2 for the location of the unit overhang on the WCP036-060F Models with BAYCURB030A,038A.

8

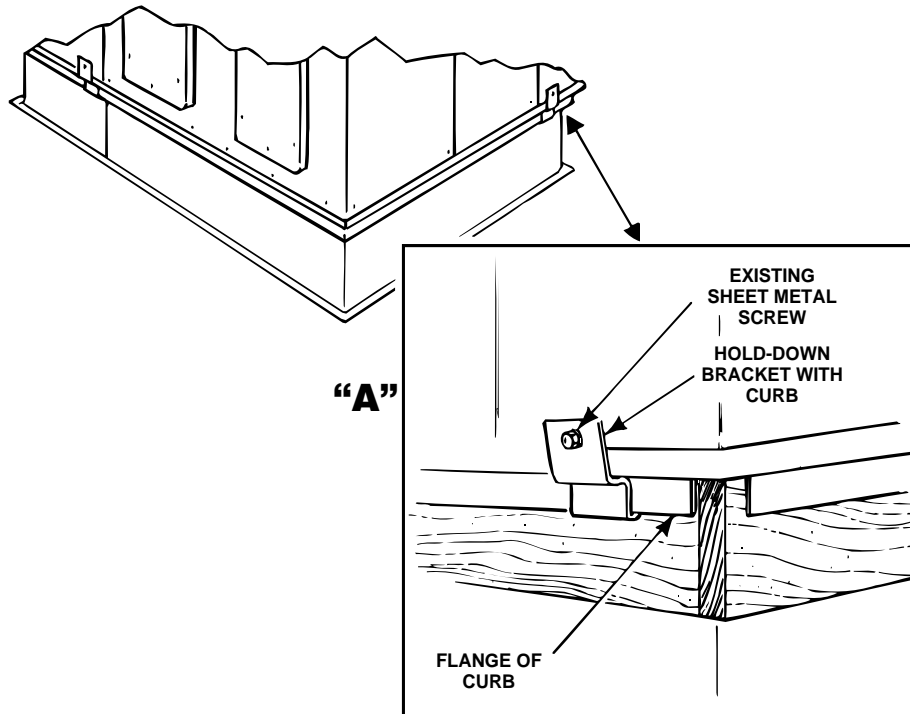

INSTALLATION

ROOFTOP -- UNITS

For roof top applications using a field fabricated frame and ducts, use the following procedure:

1. The frame must be located and secured by bolting or welding to the roof. Flashing is required.
2. The hole in the roof must be prepared in advance of installing the unit.
3. Secure the ducts to the roof.
4. Place the unit on the frame or roof curb. Refer to Figures 9 or 10.
5. Secure the unit to the frame or roof curb.
6. Insulate any ductwork outside of the structure with at least two (2) inches of insulation and then weatherproof. There must be a weatherproof seal where the duct enters the structure.
7. Complete the installation according to the instructions in the following sections of this manual.

9

TYPICAL ROOFTOP APPLICATIONS WITH FRAME

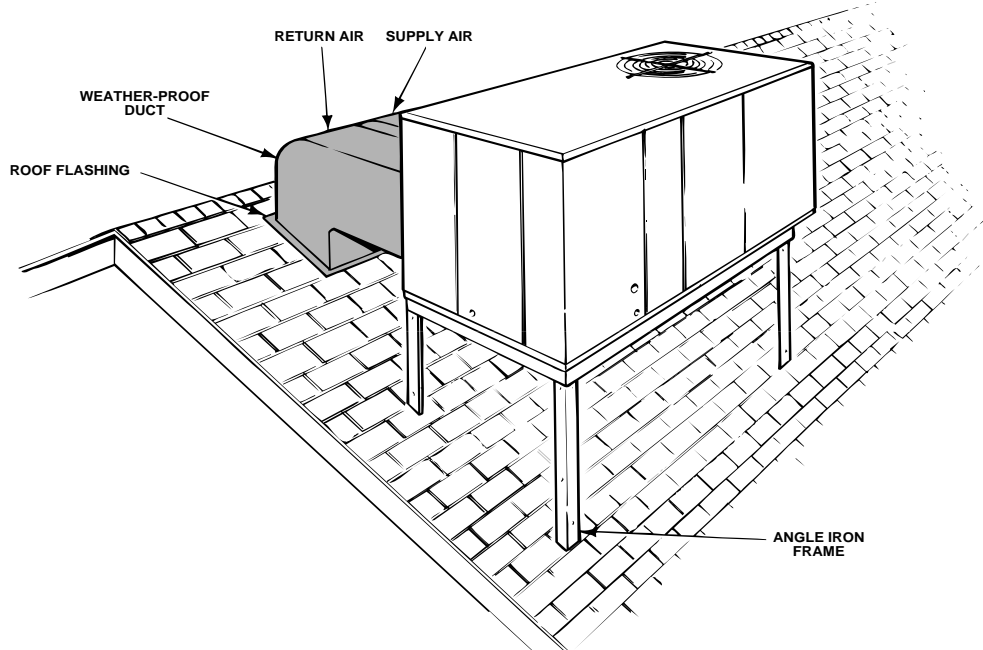

10

TYPICAL ROOFTOP APPLICATION WITH FRAME

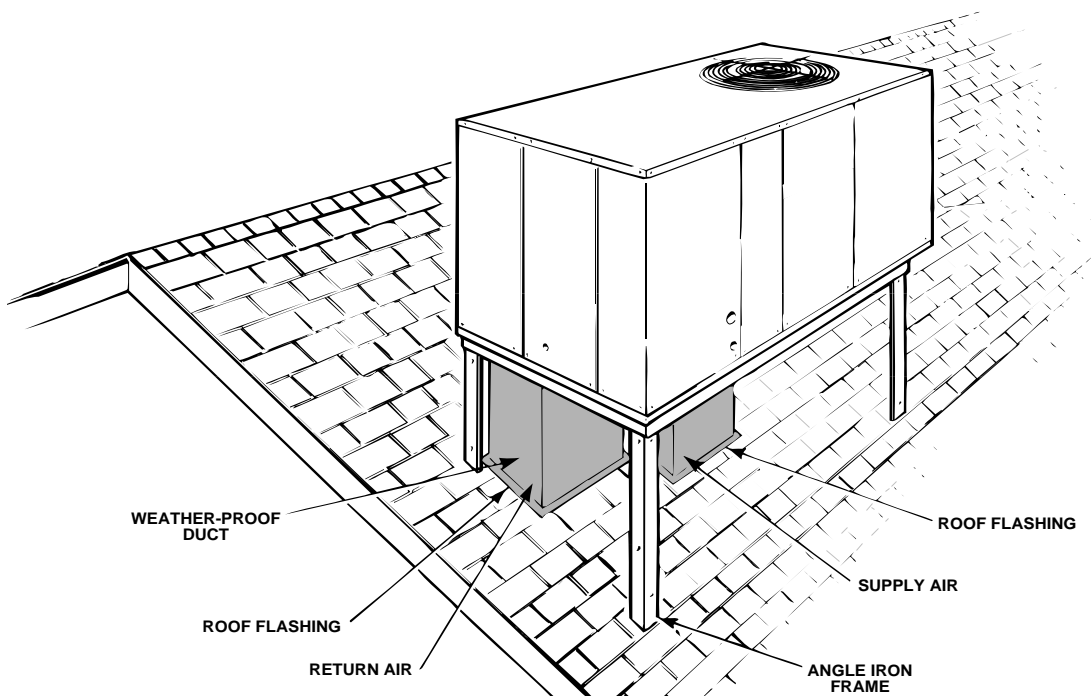

INSTALLATION

GROUND LEVEL -- HORIZONTAL UNITS

For ground level installations, the unit should be positioned on a pad the size of the unit or larger. The unit must be level on the pad. The pad must not come in contact with the structure (See Figure 11.) Be sure the outdoor portion of the supply and return air ducts are as short as possible.

Proceed with the installation as follows:

1. Place the unit on the pad and the five (5) rubber isolators provided.

2. Attach the supply and return air ducts to the unit.

3. Insulate any ductwork outside of the structure with at least 2 inches of insulation and weatherproof. There must be a weatherproof seal where the duct enters the structure.

4. Complete the installation according to the instructions in the following sections of this manual.

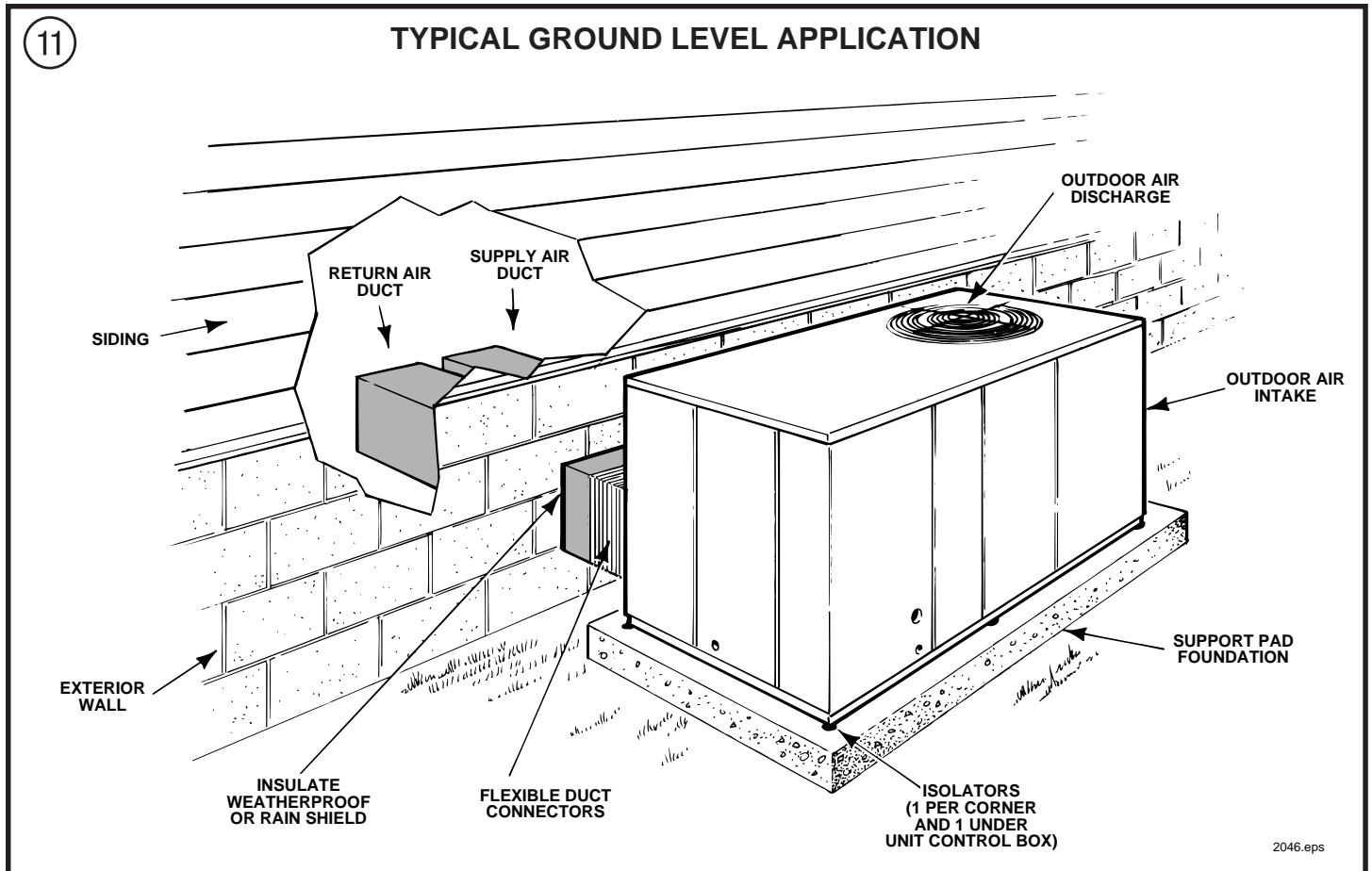

DUCTWORK

ATTACHING DOWNFLOW DUCTWORK TO ROOF CURB

Supply and return air flanges are provided on the roof curb for easy duct installation. All ductwork must be run and attached to the curb before the unit is set into place.

Follow these guidelines for ductwork construction:

Connections to the unit should be made with three-inch canvas connectors to minimize noise and vibration transmission. Elbows with turning vanes or splitters are recommended to minimize air noise and resistance.

The first elbow in the ductwork leaving the unit should be no closer than two feet from the unit, to minimize noise and resistance.

ATTACHING HORIZONTAL DUCTWORK TO UNIT

All conditioned air ductwork should be insulated to minimize heating and cooling duct losses. Use a minimum of two (2) inches of insulation with a vapor barrier. The outside ductwork must be weatherproofed between the unit and the building.

When attaching ductwork to a horizontal unit, provide a flexible watertight connection to prevent noise transmission from the unit to the ducts. The flexible connection **must** be indoors and made out of heavy canvas.

NOTE: Do not draw the canvas taut between the solid ducts.

12

DUCT ATTACHMENT METHODS

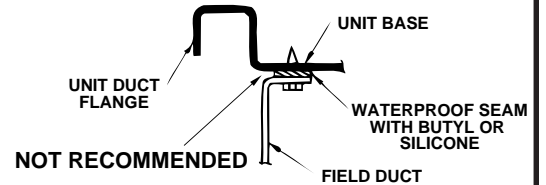
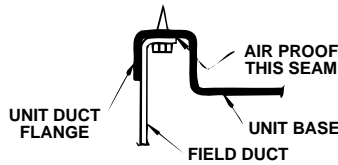
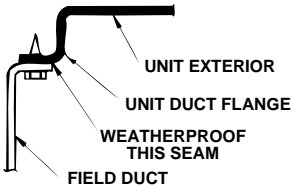
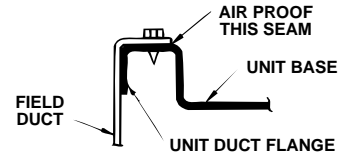
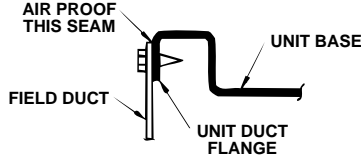
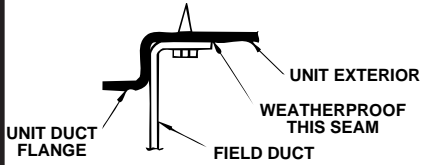

DOWNFLOW

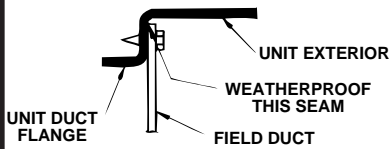

HORIZONTAL

The following warning complies with State of California law, Proposition 65.

⚠ WARNING: This product contains fiberglass wool insulation! Fiberglass dust and ceramic fibers are believed by the State of California to cause cancer through inhalation. Glasswool fibers may also cause respiratory, skin, or eye irritation.

CONDENSATE DRAIN PIPING

A 3/4-inch female NPT condensate drain connection is provided on the evaporator access panel end of the unit. See Figure 4. Provide a trap and fill it with water before starting the unit to avoid air from being drawn through. Follow local codes and standard piping practices when running the drain line. Pitch the line downward away from the unit. Avoid long horizontal runs. See Figure 13.

NOTE: Do not use reducing fittings in the drain lines. The condensate drain must be:

- Made of 3/4" pipe size.
- Pitched 1/4" per foot to provide free drainage to convenient drain system.
- Trapped.
- Must not be connected to closed drain system.

13 TYPICAL CONDENSATE DRAIN PIPING

3/4" PVC OR COPPER TUBING AND FITTINGS

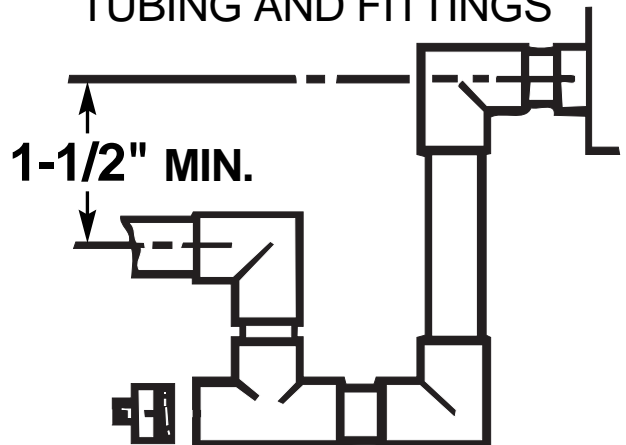

FILTER INSTALLATION

TABLE 1

AIR FILTERS

Filters are to be used with the **WCP036-060F** heating/cooling units. The basic unit does not have filters in it. However, a filter frame accessory is offered that will allow filters to be installed within the unit.

Otherwise a filter rack must be installed by the installer in the duct work.

Affix the filter label supplied with the unit adjacent to the filter area.

UNIT	NOMINAL CFM	FILTER* (Sq Ft) SIZE	FILTER RESISTANCE
WCP036F	1200	4.00	0.05
WCP048F	1600	5.33	0.05
WCP060F	2000	6.67	0.05

*Filters must be installed in the return air system. The above square footages are based on 300 F.P.M. face velocity. If permanent filters are used, size per mfg. recommendation with clear resistance of 0.05"WC.

ELECTRICAL WIRING

ELECTRICAL CONNECTIONS

Electrical wiring and grounding must be installed in accordance with local codes or, in the absence of local codes, with the National Electrical Code ANSI/NFPA 70, Latest Revision.

ELECTRICAL POWER

It is important that proper electrical power be available for the unit. Voltage variation should remain within the limits stamped on the unit nameplate.

DISCONNECT SWITCH

Provide an approved weather-proof disconnect either on the side of the unit or within close proximity and **within sight of the unit**.

OVER CURRENT PROTECTION

The branch circuit feeding the unit must be protected as shown on the unit rating plate.

POWER WIRING

The power supply lines must be run in weathertight conduit to the disconnect and into the bottom of the unit control box. Provide strain relief for all conduit with suitable connectors.

Provide flexible conduit supports whenever vibration transmission may cause a noise problem within the building structure.

Be sure all connections are made tight. See Figure 14.

NOTES: For branch circuit wiring (main power supply to unit disconnect), wire size for the length of run should be determined using the circuit ampacity found on the unit nameplate and the N.E.C.

For more than 3 conductors in a raceway or cable, see the N.E.C. for derating the ampacity of each conductor.

GROUNDING: THE UNIT MUST BE ELECTRICALLY GROUNDED IN ACCORDANCE WITH LOCAL CODES OR THE NATIONAL ELECTRIC CODE.

NOTE: Ground the unit internally as provided. See wiring diagram for location.

CONTROL WIRING (CLASS II)

Low voltage control wiring should not be run in conduit with power wiring unless Class 1 wire of proper voltage rating is used. Route the thermostat cable or equivalent single leads of No. 18 AWG colored wire from the thermostat subbase terminals through the rubber grommet on the unit. See Figure 5 for the control entry location. Make connections as shown on the unit wiring diagram and in Figure 14.

Do not short thermostat wires since this will damage the control transformer.

Recommended wire sizes and lengths for installing the unit thermostat are provided in Table 2. The total resistance of these low voltage wires must not exceed one (1) ohm. Any resistance in excess of 1 ohm may cause the control to malfunction because of the excessive voltage drop

TABLE 2
THERMOSTAT WIRE SIZE AND MAXIMUM LENGTH

WIRE SIZE	MAXIMUM LENGTH (Ft)
18	75
16	125
14	200

THERMOSTAT HEAT ANTICIPATOR

The thermostat heat anticipators should be set to equal the amperage draw of the W1 thermostat circuit.

IMPORTANT: Upon completion of wiring check all electrical connections, including factory wiring within the unit. Make sure all connections are tight. Replace and secure all electrical box covers and access doors before leaving the unit or turning on the power to the unit.

After all electrical wiring is complete, set the thermostat system switch in the OFF position so that the compressor will not run and then apply power by closing the system main disconnect switch. This will activate the compressor sump heat. Do not change the

Thermostat System Switch until power has been applied long enough to evaporate any liquid R-22 in the compressor. It is recommended that the sump heater be energized for eight (8) hours prior to starting.

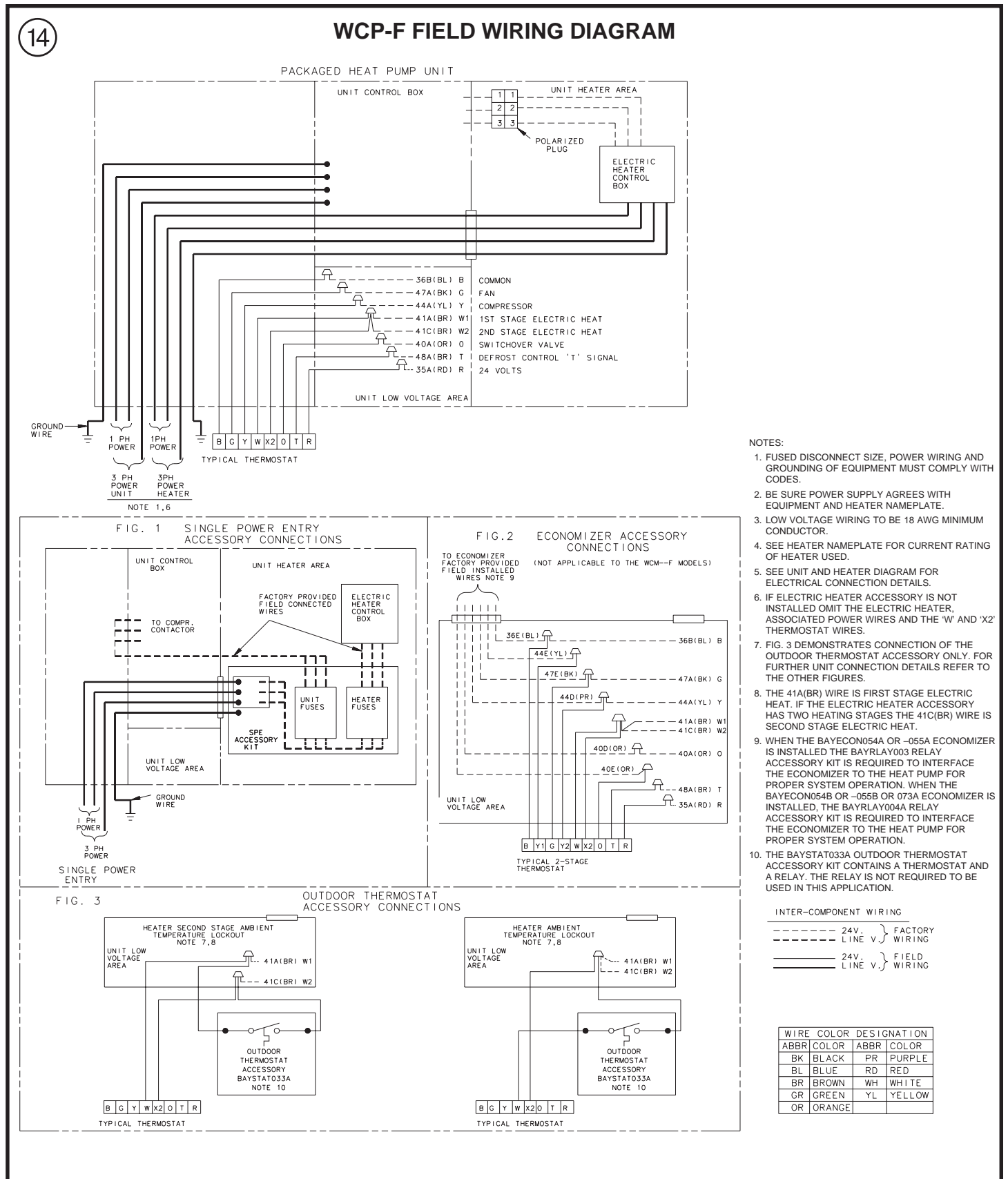

NOTES:

1. FUSED DISCONNECT SIZE, POWER WIRING AND GROUNDING OF EQUIPMENT MUST COMPLY WITH CODES.
2. BE SURE POWER SUPPLY AGREES WITH EQUIPMENT AND HEATER NAMEPLATE.
3. LOW VOLTAGE WIRING TO BE 18 AWG MINIMUM CONDUCTOR.
4. SEE HEATER NAMEPLATE FOR CURRENT RATING OF HEATER USED.
5. SEE UNIT AND HEATER DIAGRAM FOR ELECTRICAL CONNECTION DETAILS.
6. IF ELECTRIC HEATER ACCESSORY IS NOT INSTALLED OMIT THE ELECTRIC HEATER, ASSOCIATED POWER WIRES AND THE 'W' AND 'X2' THERMOSTAT WIRES.
7. FIG. 3 DEMONSTRATES CONNECTION OF THE OUTDOOR THERMOSTAT ACCESSORY ONLY. FOR FURTHER UNIT CONNECTION DETAILS REFER TO THE OTHER FIGURES.
8. THE 41A(BR) WIRE IS FIRST STAGE ELECTRIC HEAT. IF THE ELECTRIC HEATER ACCESSORY HAS TWO HEATING STAGES THE 41C(BR) WIRE IS SECOND STAGE ELECTRIC HEAT.
9. WHEN THE BAYECON054A OR -055A ECONOMIZER IS INSTALLED THE BAYRLAY003 RELAY ACCESSORY KIT IS REQUIRED TO INTERFACE THE ECONOMIZER TO THE HEAT PUMP FOR PROPER SYSTEM OPERATION. WHEN THE BAYECON054B OR -055B OR 073A ECONOMIZER IS INSTALLED, THE BAYRLAY004A RELAY ACCESSORY KIT IS REQUIRED TO INTERFACE THE ECONOMIZER TO THE HEAT PUMP FOR PROPER SYSTEM OPERATION.
10. THE BAYSTAT033A OUTDOOR THERMOSTAT ACCESSORY KIT CONTAINS A THERMOSTAT AND A RELAY. THE RELAY IS NOT REQUIRED TO BE USED IN THIS APPLICATION.

START - UP

PRE-START QUICK CHECKLIST

- Is the unit properly located and level with the proper clearance? See Figure 5.
- Is the duct work correctly sized, run, taped, insulated, and weatherproofed with proper unit arrangement. See Ductwork Installation section.
- Is the condensate line properly sized, run, trapped, and pitched?
- Is the filter of the correct size and number? Is it clean and in place?
- Is the wiring properly sized and run according to the unit wiring diagram?
- Are all the wiring connections, including those in the unit, tight?
- Has the unit been properly grounded and fused with the recommended fuse size? See Wiring Data.
- Is the thermostat level, correctly wired, well located, and set for the proper heat anticipation?
- Have the air conditioning systems been checked at the service ports for charge and leak tested if necessary?
- Do the condenser fan and indoor blower turn free without rubbing, and are they tight on the shafts?
- Has the indoor blower speed been determined and the proper speed been set? See the Unit Wiring Diagram.
- Has all work been done in accordance with applicable local and national codes?
- Are all covers and access panels in place to prevent air loss and safety hazards?

STARTING THE UNIT IN THE COOLING MODE

CAUTION: Before starting the system on the cooling cycle, turn the thermostat switch to OFF and close the unit disconnect switch. This procedure energizes the compressor crankcase heater, vaporizing any liquid refrigerant in the crankcase. This is a precaution against foaming at startup which could damage the compressor bearings. **Allow the heater to operate a minimum of eight (8) hours.**

NOTE: See the section on "Sequence of Operation" for a description of the cooling operating sequence.

⚠ WARNING: DO NOT OPERATE THE UNIT WITHOUT THE EVAPORATOR FAN ACCESS PANEL IN PLACE. REINSTALL THE ACCESS PANEL AFTER PERFORMING ANY MAINTENANCE PROCEDURES ON THE FAN. OPERATING THE UNIT WITHOUT THE ACCESS PANEL PROPERLY INSTALLED MAY RESULT IN SEVERE PERSONAL INJURY OR DEATH.

To start the unit in the cooling mode, set the thermostat system switch to COOL and move the thermostat COOL indicator to a setting below room temperature. The condenser (outdoor) fan motor compressor and evaporator (indoor) fan motor will operate automatically.

OPERATING PRESSURES

After the unit has operated in the cooling mode for a short period of time, install pressure gauges on the gauge ports of the discharge and suction line valves. Check the suction and discharge pressures and compare them to the normal operating pressures provided in the unit's *SERVICE FACTS*.

NOTE: Do not use the pressures from the unit's *SERVICE FACTS* to determine the unit refrigerant charge. The correct charge is shown on the unit nameplate. To charge the system accurately, weigh in the charge according to the unit nameplate.

VOLTAGE

With the compressor operating, check the line voltage at the unit. The voltage should be within the range shown on the unit nameplate. If low voltage is encountered, check the size and length of the supply line from the main disconnect to the unit. The line may be undersized for the length of the run.

COOLING SHUT DOWN

Place the system selector in the OFF position or reset thermostat at a setting above room temperature.

Do not de-energize the main power disconnect except when unit it to be serviced. Power is required to keep the heat pump compressor warm and boil off refrigerant in the compressor.

STARTING THE UNIT IN THE HEATING MODE

NOTE: See the section on "Sequence of Operation" for a description of the heat pump heating operating sequence.

Check to make sure all grilles and registers are open and all unit access doors are closed before start-up.

Slowly set the thermostat above room temperature until achieving a first stage call for heat and place the fan switch in the AUTO or ON position.

HEATING SHUT-DOWN

Place the system selector switch at OFF or place the heating selector lever at a setting below room temperature.

SEQUENCE OF OPERATION

GENERAL

Operation of the unit heating and cooling cycles is automatic for **HEAT** and **COOL** functions. (The optional automatic changeover thermostat, when in the **AUTO** position, automatically changes to heat or cool with sufficient room temperature change.) The fan switch can be placed in either the **ON** position, causing continuous evaporator (indoor) fan operation, or the **AUTO** position causing fan operation to coincide with heating or cooling run cycles.

COOLING MODE

(NOTE: **TSH** & **TSC** are contacts internal to the indoor thermostat.)

With the disconnect switch in the **ON** position, current is supplied to the compressor crankcase heater and control transformer. (The outdoor fan relay (**ODF**) relay is energized through normally closed contacts on the defrost timer control (**DFC**) on the 460V and 600V units only.) The cooling cycle is enabled through the low voltage side of the control transformer to the “**R**” terminal on the indoor thermostat. With the system switch in the **AUTO** position and **TSC-1** contacts closed, power is supplied to the “**O**” terminal on the indoor thermostat to the switchover valve coil (**SOV**). This energizes the switchover valve (**SOV**) and places it in the cooling position (it is in the heating position when de-energized).

When the indoor temperature rises 1-1/2 degrees, **TSC-2** contacts close, supplying power to the “**Y**” terminal on the indoor thermostat, and to the compressor contactor (**CC**). This starts the outdoor fan motor and compressor. The **TSC-2** contacts also provide power to the “**G**” terminal which provides power to the fan relay (**F**) starting the indoor fan motor.

HEATING MODE

With the disconnect switch in the “**ON**” position, current is supplied to the compressor crankcase heater and control transformer. (The outdoor fan relay (**ODF**) is energized through normally closed contacts on the defrost timer control (**DFC**) on the 460V and 600V units.) Starting at the “**R**” terminal on the indoor thermostat, current goes through the system switch (which is in “**AUTO**” position) to the **TSH-1** contacts. When closed, these contacts supply power to terminal “**Y**” on the indoor thermostat as well as to the heating anticipator. The switchover valve will not energize because of the high resistance of the heating anticipator in the thermostat. Power is provided from “**Y**” to the compressor contactor (**CC**) which starts the compressor and outdoor fan motor. The indoor thermostat contact **TSH-1** also provides power to “**G**” terminal on the indoor thermostat energizing the fan relay (**F**), which starts the indoor fan motor.

SUPPLEMENTARY HEAT

The supplementary electric heat is brought on when the indoor temperature drops 1-1/2 degrees below the thermostat setting. **TSH-2** contacts close providing power to the “**W**” terminal on the indoor thermostat and to the supplementary heater control circuit. *NOTE:* The fan relay (**F**) must have been energized. An outdoor thermostat may have been added to disallow the second stage (if provided) of electric heat above a selected outdoor temperature. If the outdoor temperature falls below the setting on the outdoor thermostat, this additional heater stage will come on. When the outdoor air temperature rises, and the outdoor T-stat setpoint is reached, the system will revert back to first stage electric heating.

When the indoor ambient is satisfied, **TSH-2** contacts will open and the unit will revert back to the compressor only heating mode and then off. For **emergency heat** (use of supplementary electric heat only), an emergency (**EMERG**) heat switch is provided within the

thermostat. When placed in the emergency heat position, it will disable the compressor, bypass the outdoor thermostats, if provided, and engage the supplementary electric heaters and indoor fan.

DEMAND DEFROST OPERATION

During the heating cycle, the outdoor coil may require a defrost cycle which is determined by the demand defrost control (**DFC**). This control continuously measures the outdoor coil temperature (**CBS**) and the outdoor ambient temperature (**ODS-B**) and calculates the difference or delta-T measurement. When the calculated delta-T is met, the demand defrost control (**DFC**) opens the circuit to the outdoor fan motor (**ODM**) and energizes the switchover valve (**SOV**), placing the unit in the cooling mode to defrost the outdoor coil. The outdoor coil temperature sensor (**CBS**) terminates the defrost cycle, or times off after twelve minutes in defrost, the (**DFC**) energizes the outdoor fan motor (**ODM**) and twelve seconds later de-energizes the (**SOV**), which returns the unit to the heating mode. Supplementary electric heat, if provided, is brought on to control indoor temperature during the defrost cycle.

ICM FAN MOTOR ADJUSTMENTS (WCP060F ONLY)

If the airflow needs to be increased or decreased, see the Airflow Table in the Service Facts. Information on changing the speed of the blower motor for the WCP060F is in the Blower Performance Table. Blower speed changes are made on the ICM Fan Control mounted in the control box. The ICM Fan Control controls the variable speed motor.

There is a bank of 8 dip switches, (See Figure 15), located at the lower right side of the board. The dip switches work in pairs to match the cooling/heat pump airflow (CFM/TON), Fan off-delay options, and electric heat airflow adjustment. The switches appear as shown in Figure 15.

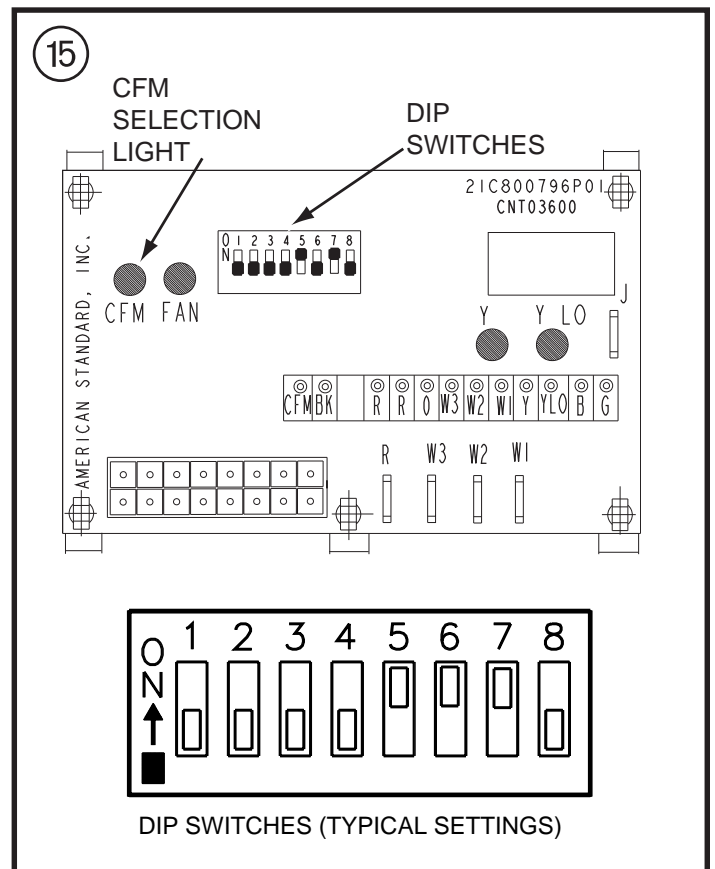

DEMAND DEFROST SYSTEM

DEFROST CONTROL

The demand defrost control measures heat pump outdoor ambient temperature with a sensor located outside the outdoor coil. A second sensor located on the outdoor coil is used to measure the coil temperature. The difference between the ambient and the colder coil temperature is the difference or delta-T measurement. This delta-T measurement is representative of the operating state and relative capacity of the heat pump system. By measuring the change in delta-T, we can determine the need for defrost. The coil sensor also serves to sense outdoor coil temperature for termination of the defrost cycle.

FAULT DETECTION

A fault condition is indicated by the flashing light on the defrost control inside the heat pump control box.

In normal operation, the defrost control light will flash once each second. If the light is flashing more than once per second or not-at-all, refer to the service manual for that unit.

PIN IDENTIFICATION (See Figure)

1. TEST_COMMON (Shorting any of the other pins to this pin causes the function of the other pin to be executed. Leaving this pin open results in the normal mode of operation.)
2. TST = Test (Shorting TEST_COMMON to this pin speeds up all defrost board timings.)
3. FRC_DFT = Forced Defrost (Short TEST_COMMON to this pin for two (2) seconds to initiate a forced defrost. Remove the short after defrost initiates.)

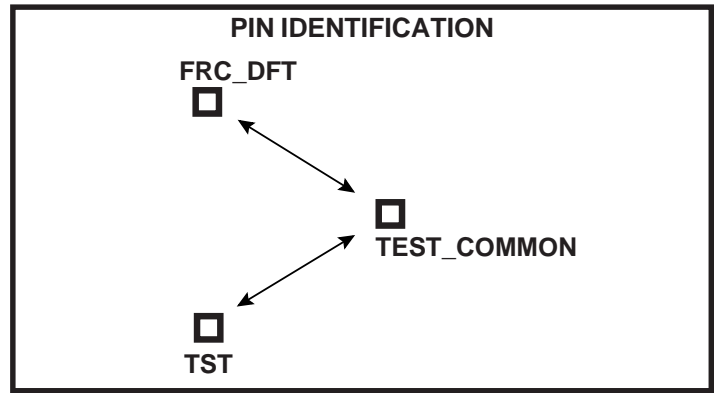

DEFROST CONTROL CHECKOUT

Normal operation requires:

- a. LED on board flashing 1 time/second.
- b. 24V AC between R & B
- c. 24V AC between Y & B with unit operating
- d. Defrost initiation when FRC_DFT pin is shorted to TEST_COMMON pin.

If a defrost control problem is suspected, proceed to DEMAND DEFROST CONTROL CHECKOUT in this Service Facts.

⚠ WARNING: Do NOT connect 24 VAC to T1 (ODS-A) terminal. ODS-A thermistor WILL BE BLOWN.

PROCEDURE FOR TESTING SENSORS

Measure the temperature the subject sensor is exposed to. If the sensor is mounted on a tube, place the lead on an Annie A-8 (or equiv.) temperature tester on the same tube near the sensor and insulate the bulb.

Unplug the sensor and measure the resistance with a good quality ohmmeter (Simpson 260 or equiv.). Read the value as quickly as possible to prevent the meter current from changing the resistance reading.

Using the chart on the right, locate (as close as possible) the actual sensor temperature. The measured resistance should be relatively close to the resistance value shown in the chart.

Example:

Sensor temp. = 19°F.

Measured Resistance = 46K ohms

This sensor is good since the measured value is relatively close to the chart value.

TEMP °F	RESISTANCE
86	7.85K
81	8.85K
75	10.24K
70	11.59K
65	13.14K
59	15.32K
55	16.93K
50	19.41K
45	22.20K
41	24.76K
36	28.45K
32	31.84K
25	37.50K
19	46.44K
14	53.94K
10	57.64K
5	67.06K
0	78.05K

FLASH RATE INDICATIONS:

- 1 — Flash/Second = Normal operation.
- 2 — Flashes/Second = Fault A (Low ΔT) i.e.: Inoperative compressor, loss of charge, open ambient sensor, shorted coil sensor.
- 3 — Flashes/Second = Fault B (20 defrosts terminated on time)
 Fault C (High ΔT) i.e.: SOV stuck in heating, shorted ambient sensor, open coil sensor, closed TXV, OD motor failure, OD fan on in defrost, undercharged unit.
- 4 — Flashes/Second = Fault A & C or A & B

For additional information consult Pub. No. 34-1001 Heat Pump Defrost Controls.

DEMAND DEFROST CONTROL CHECKOUT

SYMPTOMS	CHECKS	YES/NO	ACTIONS
1. LED off.	1. 24V R-B & Y-B at board, with unit running?	N	Repair low voltage wiring.
		Y	Complete Check #2.
	2.Short FRC_DFT pin to TEST_COMMON pin. Is defrost cycle initiated?	N	Replace defrost control.
		Y	LED is bad but control will still function.
2. LED flashing very rapidly (greater than 4 times/sec) or appears to be on continuously.	TEST_COMMON pin shorted to TST pin?	Y	Remove short.
		N	Replace defrost control.
3. Control does not initiate a normal defrost.	OD Temp. below 49°F. OD Coil temp. below 35°F? "Delta" T increasing?	N	Check refrigerant circuits for balanced distribution of refrigerant if OD coil is frosting and delta T is not increasing
		1. LED flashing?	N
	Y		Complete Check #2.
	2. Check for 24V Y-B at board with unit running.	N	Repair low voltage wiring.
		Y	Complete Check #3.
	3. Check sensors for correct mounting (connection) and resistance.		Remount or replace sensor if necessary.
	4. Short FRC_DFT pin to TEST_COMMON pin. Is defrost cycle initiated?	N	Replace defrost control.
		Y	Y-B signal or control may be intermittent
4. Control does not initiate a forced defrost.	24V R-B & Y-B at board with unit running?	N	Repair low voltage wiring.
		Y	Replace defrost control.
5. Defrost initiates manually but terminates in less than 10 seconds.			Replace defrost control.
6. Defrost initiates manually but terminates on time.	1. Coil sensor circuit open or reading at a very high resistance?	Y	Replace coil sensor.
	2. Does OD fan cycle off in defrost?	N	Replace defrost control.
	3. Windy weather preventing normal termination?		
7. Defrost initiates on approximately 15/25 minute intervals.	Be sure OD coil is clean.	N	Complete Check #2.
	1. Coil sensor open or reading a very high resistance?	Y	Replace coil sensor.
	2. Ambient sensor reading less than normal?	N	Complete Check #3.
		Y	Replace ambient sensor.
3. OD fan off in defrost?	N	Replace defrost control.	
8. Defrost initiates on approximately 30/45 minute intervals.	1.TEST_COMMON pin shorted to TST pin?	Y	Remove short.
	2. Do both sensors check OK?	N	Replace defective sensor (Clear coil and reset Emergency heat light).
		Y	Complete SYMPTOM #3.
	3. Verify correct system charge.		Adjust as needed.
	4. Verify a "forced defrost" terminates less than 15 minutes.	N	Replace defrost control.
	5. OD fan motor off in defrost.		See SYMPTOM #9.
6. Verify proper SOV operation.		Replace if necessary.	
9. OD fan runs during defrost.			Replace defrost control.
10. No SOV delay on defrost termination.	Has J1 been cut?	Y	The soft-switch time is defeated when J1 is cut.
		N	Replace defrost control.
11. ODS-A burned out.	1. B to T greater than 10 volts?	Y	Check low voltage wiring for miswire.
		N	Check for short in low voltage wiring.
12. On SCROLL bearing units, compressor does not operate.	1. 24V R-B at board & 24V Y-B at board?	N	Repair low voltage wiring.
	2. Check protective devices in YO circuit . 24V YO-B present after 30 seconds.	N	Y-B signal or control may be intermittent
13. On SCROLL bearing units, no 30 second off delay at defrost initiation.	Check voltage between control terminals 2 and 7,force a defrost cycle. Is 24V present for 30 seconds and 0V thereafter?	N	Replace defrost control.

MAINTENANCE

ROUTINE MAINTENANCE BY OWNER

You can do some of the periodic maintenance functions for your **WCP-F** unit yourself; this includes replacing the disposable or cleaning the permanent air filters, cleaning the unit cabinet, clearing the condenser coil, and conducting a general unit inspection on a regular basis.

Be sure to inspect them at least once each month when the system is in constant operation. (In new construction, check the filters every week for the first four (4) weeks.)

If you have disposable-type filters, replace them with new filters of the same type and size. **Do not attempt to clean disposable filters.**

Permanent-type filters can be cleaned by washing them with a mild detergent and water. Make sure that the filters are thoroughly dry before re-installing them in the unit (or duct system).

NOTE: It may be necessary to replace permanent filters annually if washing fails to clean the filter or if the filter shows signs of deterioration. Be sure to use the same type and size as was originally installed.

CONDENSER COIL

Unfiltered air circulates through the unit's condenser coil and can cause the coil's surface to become clogged with dust, dirt, etc. To clean the coil, vertically (i.e., with the fins) stroke the coil surface with a soft-bristled brush.

Be sure to keep all vegetation away from the condenser coil area.

MAINTENANCE PERFORMED BY SERVICEMAN--COOLING SEASON

To keep your unit operating safely and efficiently, the manufacturer recommends that a qualified serviceman check the entire system at least once each year and any other time that you feel one is needed. Your serviceman should examine these areas of your WCP-F unit:

- filters (for cleaning or replacement)
- motors and drive system components
- gaskets (for possible replacement)
- safety controls (for mechanical cleaning)
- electrical components and wiring (for possible replacement and connection tightness)
- condensate drain (for cleaning)
- unit duct connections (to see that they are physically sound and sealed to the unit casing)
- unit mounting support (for structural integrity)
- the unit (for obvious unit deterioration)

MAINTENANCE PERFORMED BY SERVICEMAN--HEATING SEASON

Complete the unit inspections and service routines described below at the beginning of each heating season.

- Visually inspect the unit to ensure that the airflow required for condenser coil is not obstructed from the unit.
- Inspect the control panel wiring to verify that all electrical connections are tight and that the wire insulation is intact.

⚠ WARNING: TO PREVENT INJURY OR DEATH DUE TO ELECTRICAL SHOCK OR CONTACT WITH MOVING PARTS. LOCK UNIT DISCONNECT SWITCH IN OPEN POSITION BEFORE SERVICING UNIT.

⚠ WARNING: TO PREVENT AN EXPLOSION OR POSSIBLE INJURY, DEATH AND EQUIPMENT DAMAGE, DO NOT STORE COMBUSTIBLE MATERIALS, GASOLINE OR OTHER FLAMMABLE VAPORS OR LIQUIDS NEAR THE UNIT.

The following warning complies with State of California law, Proposition 65.

⚠ WARNING: This product contains **fiberglass wool insulation!** Fiberglass dust and ceramic fibers are believed by the State of California to cause cancer through inhalation. Glasswool fibers may also cause respiratory, skin, or eye irritation.

PRECAUTIONARY MEASURES

- Avoid breathing fiberglass dust.
- Use a NIOSH approved dust/mist respirator.
- Avoid contact with the skin or eyes. Wear long-sleeved, loose-fitting clothing, gloves, and eye protection.
- Wash clothes separately from other clothing: rinse washer thoroughly.
- Operations such as sawing, blowing, tear-out, and spraying may generate fiber concentrations requiring additional respiratory protection. Use the appropriate NIOSH approved respirator in these situations.

FIRST AID MEASURES

Eye Contact - Flush eyes with water to remove dust. If symptoms persist, seek medical attention.

Skin Contact - Wash affected areas gently with soap and warm water after handling.

LIMITED WARRANTY
HIGH EFFICIENCY HEAT PUMP
WCC, WCD, WCH, WCM, WCP AND WSC
Models Less Than 20 Tons for Residential Use*
(Parts Only)

This limited warranty is extended by American Standard Inc., to the original purchaser and to any succeeding owner of the real property to which the Heat Pump is originally affixed, and applies to products purchased and retained for use within the U.S.A. and Canada.

If any part of your Heat Pump fails because of a manufacturing defect within five years from the date of the original purchase, Warrantor will furnish without charge the required replacement part. Any local transportation, related service labor, diagnosis calls, refrigerant and related items are not included.

If the sealed motor-compressor fails or if the outdoor coil should become defective, either or both events occurring because of a manufacturing defect within five years from the date of original purchase, Warrantor will furnish without charge the required replacement compressor and/or outdoor coil. Any local transportation, related service labor, diagnosis calls, refrigerant and related items are not included.

This limited warranty does not cover failure of your Heat Pump if it is damaged while in your possession, damage caused by unreasonable use of the Heat Pump and/or damage from **failure to properly maintain** the Heat Pump as set forth in the American Standard Use and Care manual (**see Proper Maintenance section**).

This limited warranty applies to product installed on or after 10/1/2001 where product is manufactured after 1/1/2000. This limited warranty is not retroactive to any installations prior to 10/1/2001 or on product produced prior to 2000.

THE LIMITED WARRANTY AND LIABILITY SET FORTH HEREIN ARE IN LIEU OF ALL OTHER WARRANTIES AND LIABILITIES, WHETHER IN CONTRACT OR IN NEGLIGENCE, EXPRESS OR IMPLIED, IN LAW OR IN FACT, INCLUDING IMPLIED WARRANTIES OF MERCHANTABILITY AND FITNESS FOR PARTICULAR USE, AND IN NO EVENT SHALL WARRANTOR BE LIABLE FOR ANY INCIDENTAL OR CONSEQUENTIAL DAMAGES.

Some states do not allow limitations on how long an implied limited warranty lasts or do not allow the exclusion or limitation of incidental or consequential damages, so the above limitation or exclusion may not apply to you. This limited warranty gives you specific legal rights, and you may also have other rights which vary from state to state.

Parts will be provided by our factory organization through an authorized service organization in your area listed in the yellow pages. If you wish further help or information concerning this limited warranty, contact:

American Standard Inc.
Troup Highway
Tyler, TX 75711-9010
Attention: Manager, After Sales Support

GW-625-1802

*This limited warranty is for residential usage of this equipment and not applicable when this equipment is used for a commercial application. A commercial use is any application where the end purchaser uses the product for other than personal, family or household purposes.

LIMITED WARRANTY
HIGH EFFICIENCY HEAT PUMP
WCZ, WCY, WCX, WCP, WCC, WCD, WCH, WCM AND WSC
Models Less Than 20 Tons for Commercial Use*
(Parts Only)

This warranty is extended by American Standard Inc., to the original purchaser and to any succeeding owner of the real property to which the Heat Pump is originally affixed, and applies to products purchased and retained for use within the U.S.A. and Canada. There is no warranty against corrosion, erosion or deterioration.

If any part of your Heat Pump fails because of a manufacturing defect within one year from the date of the original purchase, Warrantor will furnish without charge the required replacement part.

In addition, if the sealed motor-compressor fails because of a manufacturing defect within the second through fifth year from the date of original purchase, Warrantor will furnish without charge the required replacement compressor. Warrantor's obligations and liabilities under this warranty are limited to furnishing F.O.B. Warrantor factory or warehouse replacement parts for Warrantor's products covered under this warranty. Warrantor shall not be obligated to pay for the cost of lost refrigerant. No liability shall attach to Warrantor until products have been paid for and then liability shall be limited solely to the purchase price of the equipment under warranty shown to be defective.

THE WARRANTY AND LIABILITY SET FORTH HEREIN ARE IN LIEU OF ALL OTHER WARRANTIES AND LIABILITIES, WHETHER IN CONTRACT OR IN NEGLIGENCE, EXPRESS OR IMPLIED, IN LAW OR IN FACT, INCLUDING IMPLIED WARRANTIES OF MERCHANTABILITY AND FITNESS FOR PARTICULAR USE, AND IN NO EVENT SHALL WARRANTOR BE LIABLE FOR ANY INCIDENTAL OR CONSEQUENTIAL DAMAGES.

Some states do not allow limitations on how long an implied warranty lasts or do not allow the exclusion or limitation of incidental or consequential damages, so the above limitation or exclusion may not apply to you. This warranty gives you specific legal rights, and you may also have other rights which vary from state to state.

American Standard Inc.
Troup Highway
Tyler, TX 75711-9010
Attention: Manager, After Sales Support

GW-604-4800

* This warranty is for commercial usage of said equipment and not applicable when the equipment is used for a residential application. Commercial use is any application where the end purchaser uses the product for other than personal, family or household purposes.

Since American-Standard has a policy of continuous product and product data improvement, it reserves the right to change design and specification without notice.

American-Standard Inc.
6200 Troup Highway
Tyler, TX 75703



Technical Literature - Printed in U.S.A.