



TRANE™

Installation/Operation/ Maintenance

EMTX-IOM-5
(22-6010-01)

December, 1993

TCM

Thermostat Control Module

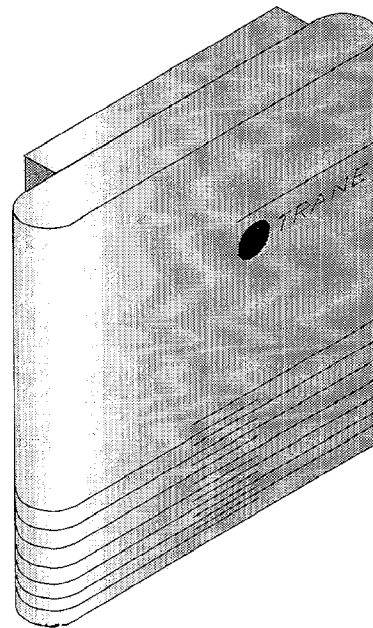

Note

This manual applies to the TCM hardware with board assemblies numbered 50100825 or 50100826. All TCMs with board assembly numbers lower than these, should refer to previous versions of this Installation/Operation/Maintenance Guide.

Part Numbers:

4950-0372 -- Standard Ambient Enclosure (NEMA 1)
4950-0373 -- Extended Ambient Enclosure (NEMA1)
4950-0374 -- Weatherproof Enclosure (NEMA4)

KBA-4950-0372 -- Standard Ambient Enclosure (NEMA 1)
KBA-4950-0373 -- Extended Ambient Enclosure (NEMA1)
KBA-4950-0374 -- Weatherproof Enclosure (NEMA4)

Since The Trane Company has a policy of continuous product improvement, it reserves the right to change specifications and design without notice. The installation and servicing of equipment referred to in this booklet should be done by qualified, experienced technicians.

Table of Contents

Specifications	3	I/O Wiring Requirements	14
General Information	4	Analog Input (Temperature Sensor) Wiring	15
Unit Description	4	Room Sensor Mounting	16
Binary Outputs	4	Binary Input Wiring	18
Analog Inputs	4	Binary Output Wiring	19
Binary Inputs	4	Example of TCM I/O Assignment Sheet	20
Configuration and Address DIP Switches	4	Blank TCM I/O Assignment Sheet	21
Communication Link	4	Installation Checklist	22
Shipment	4		
Storage	4	Operation	23
Typical TCM Application	5	TCM Output Control	23
		- Slave Mode	23
		- Thermostat Modes	23
		TCM Input Monitoring	24
		- Temperature Inputs	24
		- Binary Inputs	24
		Setpoint Adjustment	25
		LED Operation	25
Installation	7	Maintenance	26
Unit Mounting	7	Test Mode	26
- Location Within Building	7	Binary Output Checks	26
- Operating Environment	7	Analog and Binary Input Checks	27
- Clearances	7	Communication Link Checks	27
- Mounting	7		
AC Power Wiring	10		
- Power Supply	10		
- AC Power Connections	10		
- AC Power Checkout	10		
Communication Link Wiring	10		
DIP Switch Settings	12		
Input/Output Wiring	14		

Literature File Information	
Library	Service Literature
Product Section	Electronic Systems and Controllers
Product	Building Automation Systems
Model	EMTX
Literature Type	Installation-Operation-Maintenance
Sequence	5
Date	12/93
File No.	SV-ES-BAS-EMTX-IOM-5-1293
Supersedes	EMTX-IOM-4A 1291

List Price \$6.00

The Trane Company
La Crosse, Wisconsin 54601-7599
Printed in U.S.A.

© American Standard Inc. 1993

Specifications

Power Requirements

20-30 VAC, 60 Hz, 1 Ph
30 VA Minimum
Dedicated Transformer Required

Operating Environment

30° to 120° F (-1° to 49° C) for Standard Ambient TCM
-40° to 158° F (-40° to 70° C) for Extended Ambient
and Weatherproof TCM
5 to 95% relative humidity, non-condensing

Storage Environment

-50° to 200° F (-46° to 93° C)
5 to 95% relative humidity, non-condensing

Cabinet

NEMA 1 Enclosure for Standard Ambient TCM
NEMA 1 Enclosure for Extended Ambient TCM
NEMA 4 Enclosure for Weatherproof TCM

Mounting

Standard Ambient NEMA 1 enclosure: Mounted on flat surface with # 8 (M4) hardware
Extended Ambient NEMA 1 enclosure: Mounted on flat surface with # 8 (M4) hardware
Weatherproof NEMA 4 enclosure: Mounted on flat surface with 1/4" (M6) hardware

Dimensions

Standard Ambient NEMA 1 enclosure:
12" (305 mm) high x 9-13/16" (249 mm) wide x 2-13/16" (71 mm) deep
Extended Ambient NEMA 1 enclosure: 9" (229 mm) high x 8-1/4" (210 mm) wide x 2-1/4" (57 mm) deep
Weatherproof NEMA 4 enclosure: 8" (203 mm) high x 10" (254 mm) wide x 4" (102 mm) deep

Weight

Standard Ambient NEMA 1 enclosure: 4 lbs (1.8 kg)
Extended Ambient NEMA 1 enclosure: 3 lbs (1.4 kg)
Weatherproof NEMA 4 enclosure: 9 lbs (4.1 kg)

Communication Link Wiring

Communication Link wiring must be 18 AWG twisted, shielded pair wire. Each conductor must be stranded tinned copper. Maximum total wire length is 5,000 feet (1524 m). Refer to chart below.

Maximum Communication Link Wiring Length for TCM

Maximum Communication Link Wiring Length	Maximum Capacitance Between Conductors
1,000 feet (305 m)	Up to 60 PF/FT (197 PF/m)
2,000 feet (610 m)	Up to 50 PF/FT (164 PF/m)
3,000 feet (914 m)	Up to 40 PF/FT (131 PF/m)
4,000 feet (1219 m)	Up to 30 PF/FT (98 PF/m)
5,000 feet (1524 m)	Up to 25 PF/FT (82 PF/m)

Analog Temperature Inputs

-30° to 220° F (-34° to 104° C)

Binary Inputs

Voltage Provided: 24 VAC
Current Provided: 8 to 12 mA

Relay Contact Rating

Maximum 30 VAC/VDC, 1 Amp, 24 VA Pilot Duty
Minimum 200 microamp, 5 VDC

Agency Approvals

Underwriters Laboratories, Inc. - listed for UL916 (PAZX) Enclosed Energy Management Equipment. The Standard Ambient NEMA 1 TCM is suitable for mounting in an air plenum.

FCC - Part 15, Subpart J, Computing Devices: Complies with FCC Class A electromagnetic emission requirements for a computing device.

CISPR Publication 11:1990 and EN5011:1991 with Group 1, Class A limits defined in the European norm for radio disturbance characteristics of industrial, scientific, and medical (ISM) equipment.

General Information

Unit Description

The TCM (Thermostat Control Module) is a control module designed for communication with a Trane Building Management System (BMS), which includes Tracer Summit, Tracer 100 Series panels, Tracer 1000, Tracker, or ComforTrac. The TCM can either provide "slave" input/output points for the Trane BMS or function as a "thermostat" for air conditioning units and heat pumps.

In the "slave" mode, the Trane BMS monitors the TCM input points and directly controls the TCM output points.

In the "thermostat" mode, the TCM monitors its own sensors, and controls its outputs like a wall thermostat. The TCM can be configured as either an air conditioning thermostat or a heat pump thermostat. This control is self-contained within the TCM, and the TCM can operate standalone (without the Trane BMS) during system startup or in the event of a communications loss.

Use of the TCM allows the Trane BMS to perform functions such as scheduling, night setback, demand limiting, and so on.

Important: Refer to the appropriate literature for each Trane BMS to determine the available features for that product.

Figure 1 shows a typical TCM application. Figure 2 illustrates the component layout of the TCM.

Binary Outputs

The TCM has six binary (relay) outputs. Each output has a set of normally open/normally closed (form C) contacts. When the TCM is used in the "slave" mode, the Trane BMS directly controls the TCM output points. When the TCM is used in the "thermostat" mode, outputs # 1 through # 5 are controlled by the TCM, and output # 6 (spare) is controlled directly by the Trane BMS.

Analog Inputs

The TCM has three analog temperature inputs. When the TCM is used in the "slave" mode, these analog input points are user defined (Trane thermistor temperature sensors only). When the TCM is used in the "thermostat" mode, analog input # 1 must be used for the zone temperature sensor, analog input # 2 can be used for the optional zone setpoint adjustment or be user defined, and analog input # 3 is user defined.

Binary Inputs

The TCM has three binary inputs. These binary input points are user defined. Each input can monitor a set of isolated, ungrounded contacts, such as a differential pressure airflow switch.

Configuration and Address DIP Switches

The TCM has eight DIP switches (S1-1 through S1-8) for setting the communication link address and configuring the TCM for one of four program options: slave, air conditioning thermostat, heat pump thermostat, and test mode.

Communication Link

The TCM has a serial communication link to allow it to communicate with a Trane BMS panel over a twisted, shielded pair of wires. TCMs can be directly connected to a Tracer 100 Series panel, Tracer Summit Building Control Unit (BCU), Tracker, or ComforTrac, and are connected to a Tracer 1000 through a Unit Control Interface (UCI). Up to 48 TCMs can be connected on a single communication link, depending on the type of Trane BMS panel. Refer to the applicable Trane BMS installation manual for details on the Trane BMS capabilities.

Shipment

The TCM and service literature are shipped in the same package. When unpacking, make sure that the literature is not lost or discarded with the packing material.

Visually inspect the TCM for obvious defects or damage. All components are thoroughly inspected before leaving the factory. Any claims for damage incurred in shipping should be filed with the carrier.

Storage

If the unit is to be stored for a period of time, the storage temperature should be -50° to 200° F (-46° to 93° C). The relative humidity of the storage location should be 5 to 95 percent, non-condensing. A controlled indoor environment is recommended for storage.

Figure 1
Typical TCM Application

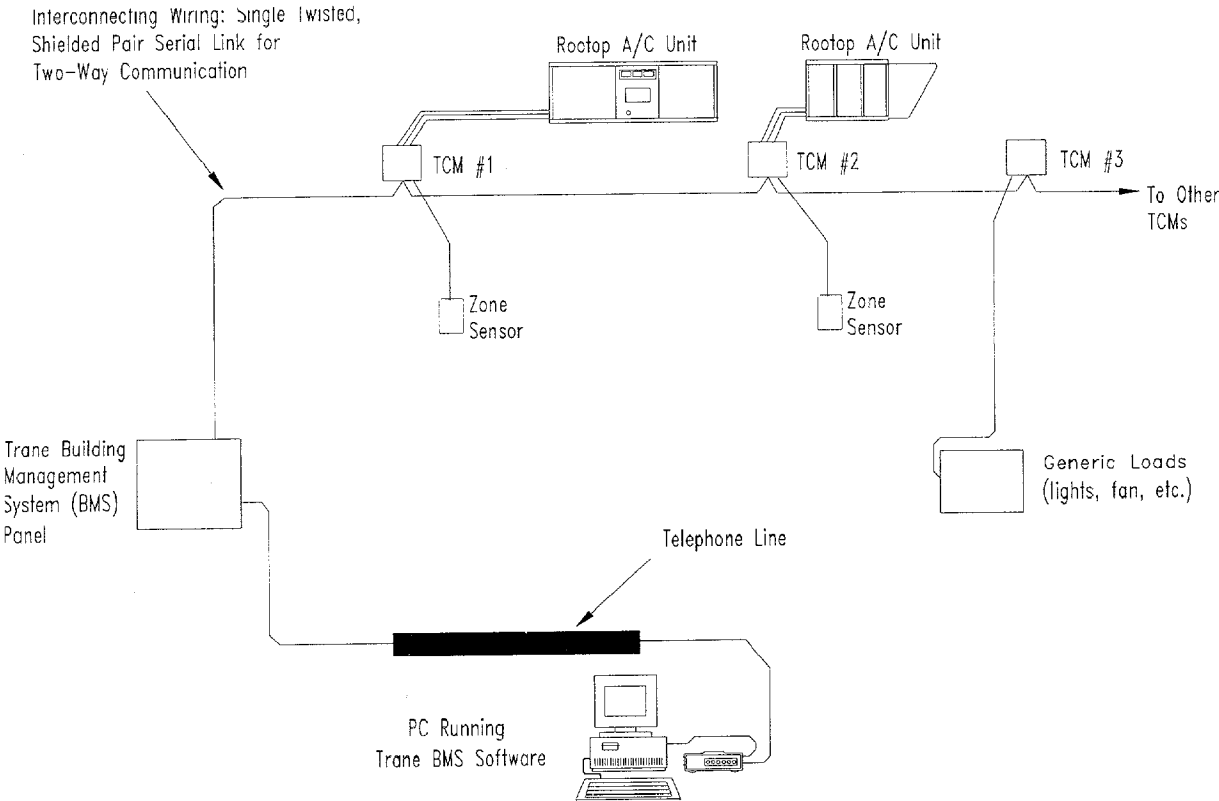
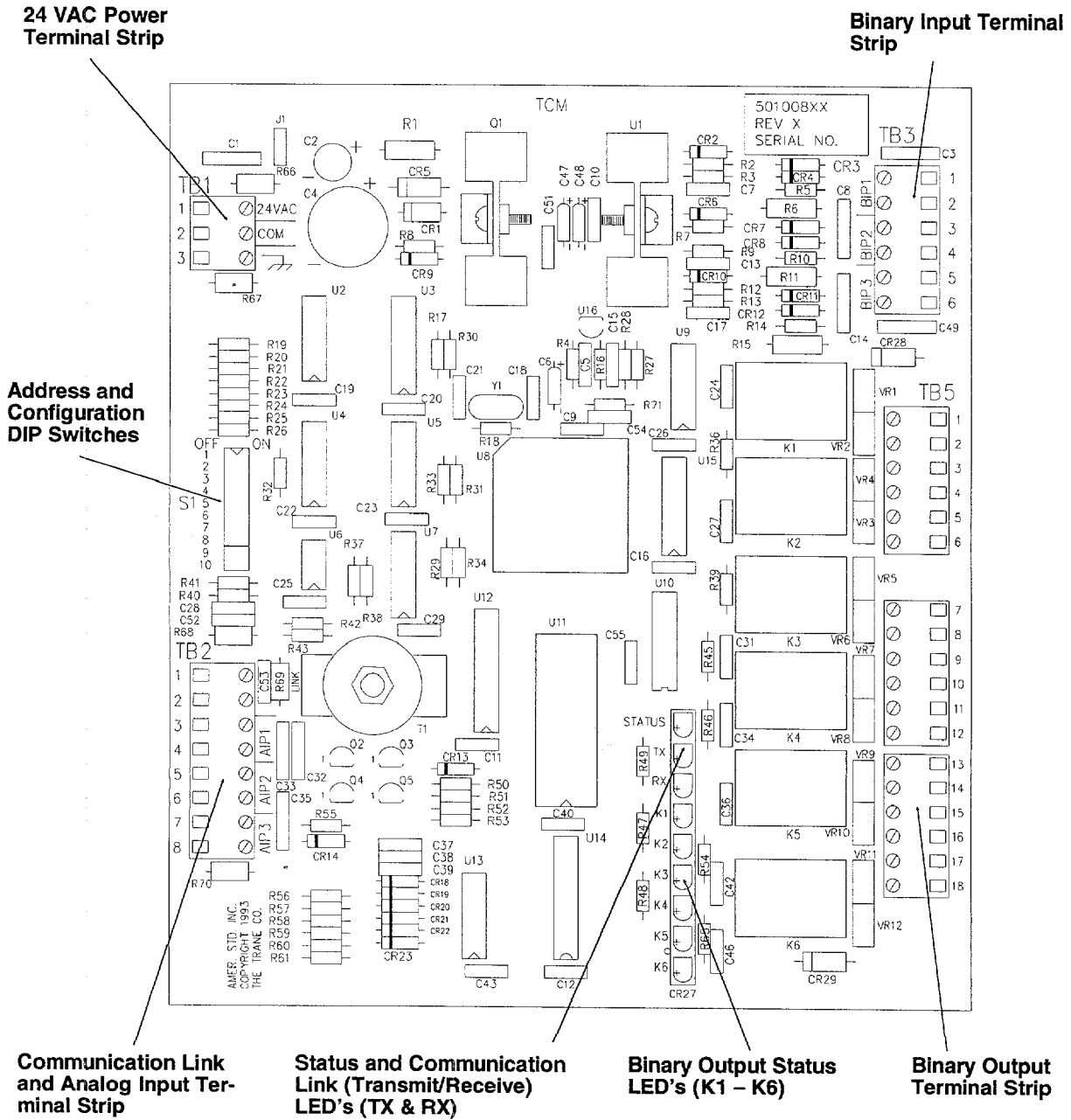

Figure 2
TCM Component Layout



Installation

Unit Mounting

Location Within Building

The TCM should be mounted near the controlled equipment to reduce wiring costs. The location should also be based on the type of enclosure selected (see Table 1). The TCM should be accessible for service personnel.

Operating Environment

There are three options of the TCM available for use in different mounting locations and environments: 1) standard, 2) extended ambient, and 3) weatherproof. The standard and extended ambient TCMs should be located in a dust-free and corrosive-free indoor (or weather protected) environment. The environmental ratings for these three options are listed in Table 1.

Clearances

The standard TCM should be wall-mounted vertically. It is approximately 12" (305 mm) high, 9-13/16" (249 mm) wide, and 2-13/16" (71 mm) deep (see Figure 3).

The extended ambient and weatherproof TCMs can be mounted on any flat surface either horizontal or vertical.

The extended ambient panel is approximately 9" (229 mm) high, 8-1/4" (210 mm) wide, and 2-1/4" (57 mm) deep (see Figure 4). With the cover removed, the installer has access to the front, left, and right sides, while the top and bottom of the panel are stationary.

The weatherproof panel is approximately 8" (203 mm) high, 10" (254 mm) wide, and 4" (102 mm) deep (see Figure 5). With the cover removed, the installer has access through the front only.

When mounted, the TCM should be easily accessible for making wire connections and for servicing. Provide 2" (51 mm) of clearance on the left and right sides, and sufficient clearance above and below the unit to make conduit connections. At least 24" (610 mm) should be available in front of the unit for making wire connections and performing maintenance.

Mounting

On the standard enclosure TCM, three 3/16" (5 mm) holes are provided for mounting; use # 8 (M4) mounting screws. Figure 3 shows the standard TCM dimensions. The unit weighs approximately 4 lbs (1.8 kg).

Table 1
TCM Environmental Ratings

TCM Option	Type of Enclosure	Operating Ambient	
		Temperature	Humidity
Standard Ambient Enclosure (Indoor Wall Mount)	NEMA 1 (Resin)	30° to 120° F (-1° to 49° C)	5 to 95 % Non-condensing
Extended Ambient Enclosure (Indoor or Control Panel Mount)	NEMA 1 (Steel)	-40° to 158° F (-40° to 70° C)	5 to 95 % Non-condensing
Weatherproof Enclosure (Outdoor Mount)	NEMA 4 (Steel)	-40° to 158° F (-40° to 70° C)	Rain, Splashing, and Hose-directed water

Note: Extended ambient ratings are typically required for mounting inside HVAC equipment control panels. For example, the control panel temperature on rooftop air conditioners can exceed 140° F (60° C).

Installation

On the NEMA 1 extended ambient enclosure TCM, four 3/16" (5 mm) holes are provided for mounting; use # 8 (M4) mounting hardware. Figure 4 on page 9 shows the NEMA 1 unit mounting dimensions. The unit weighs approximately 3 lbs (1.4 kg).

On the NEMA 4 weatherproof enclosure TCM, four 5/16" (8 mm) holes are provided for mounting; use 1/4" (M6) mounting hardware. Figure 5 on page 9 shows the NEMA 4 unit mounting dimensions. The unit weighs approximately 9 lbs (4.1 kg).

Figure 3
Dimensions for Standard TCM
Enclosure

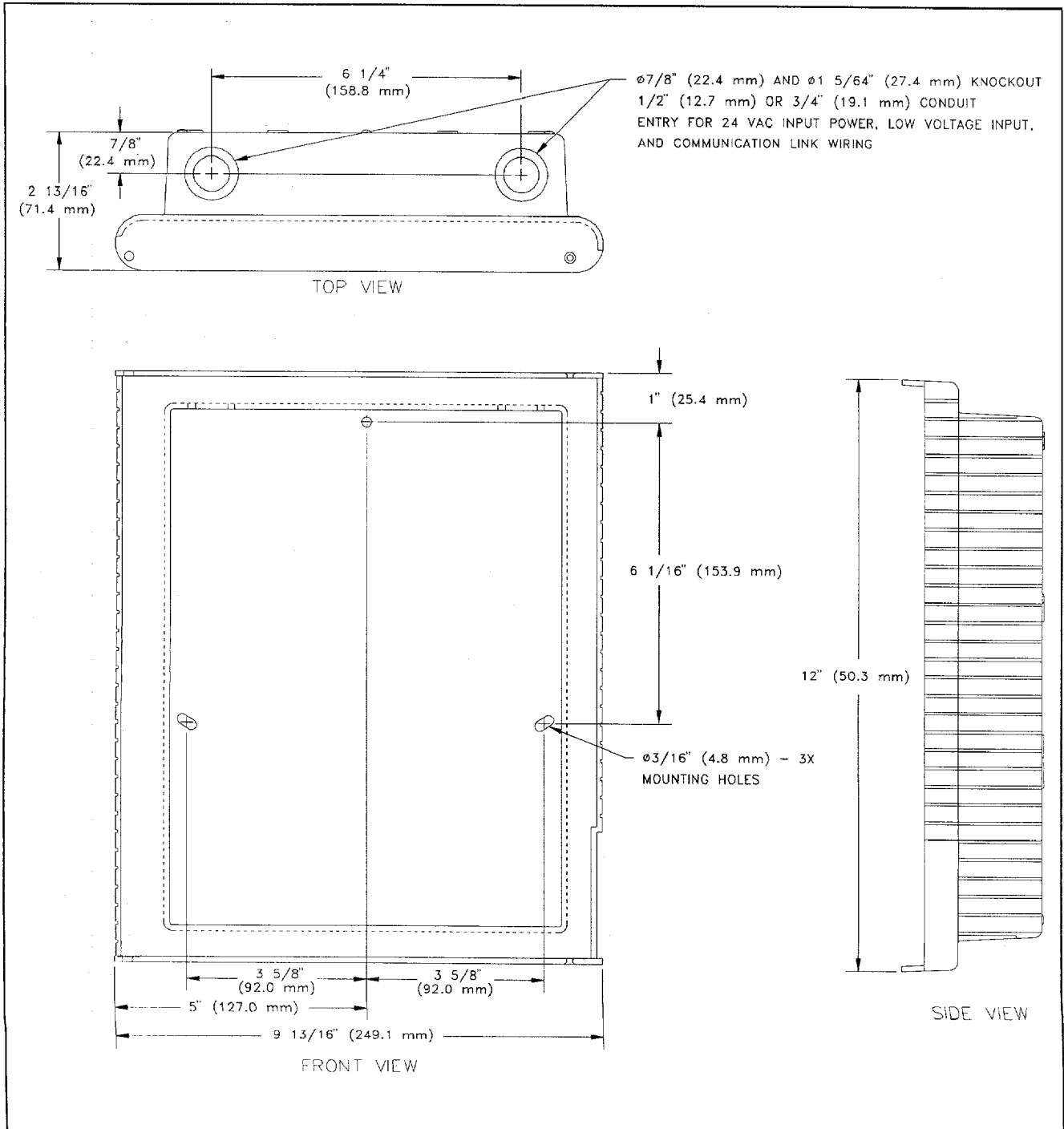

Figure 4
Dimensions for TCM Extended Ambient (NEMA 1) Enclosure

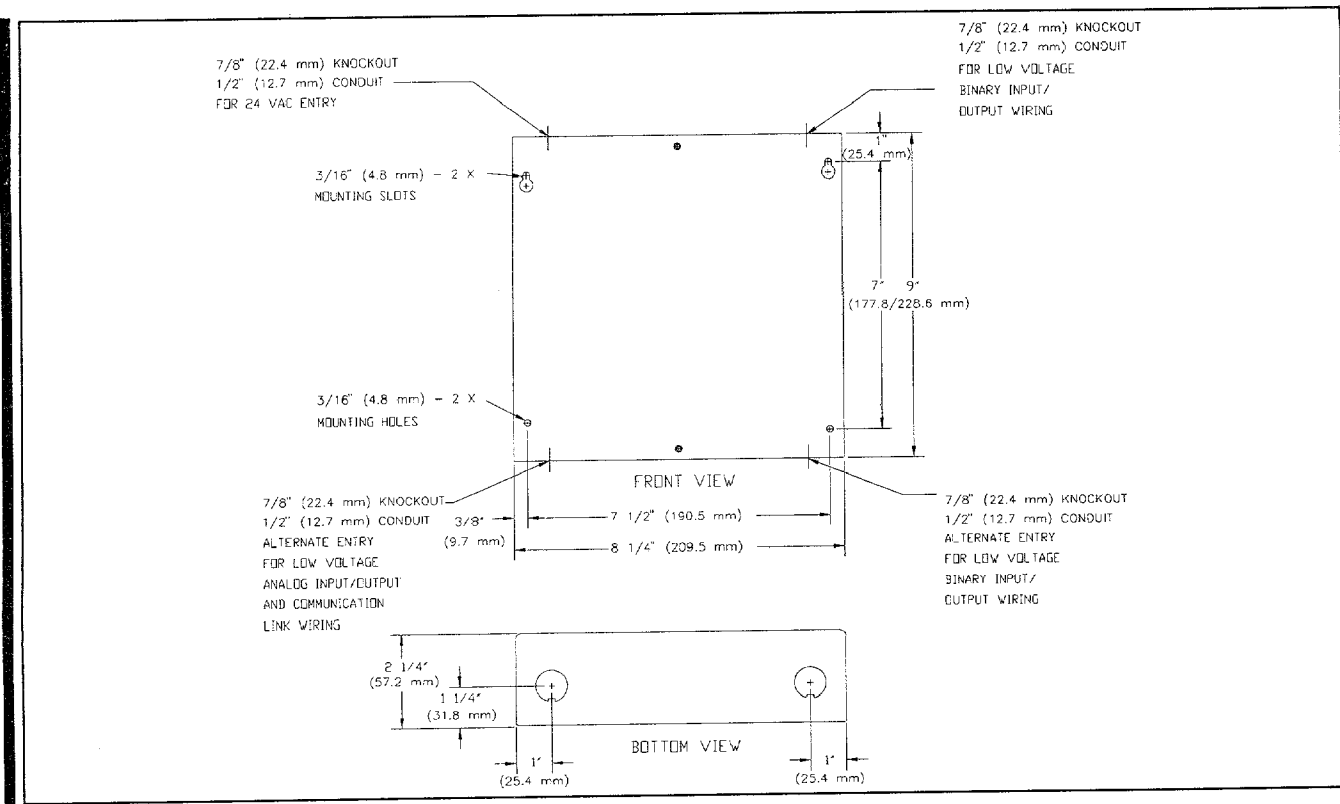
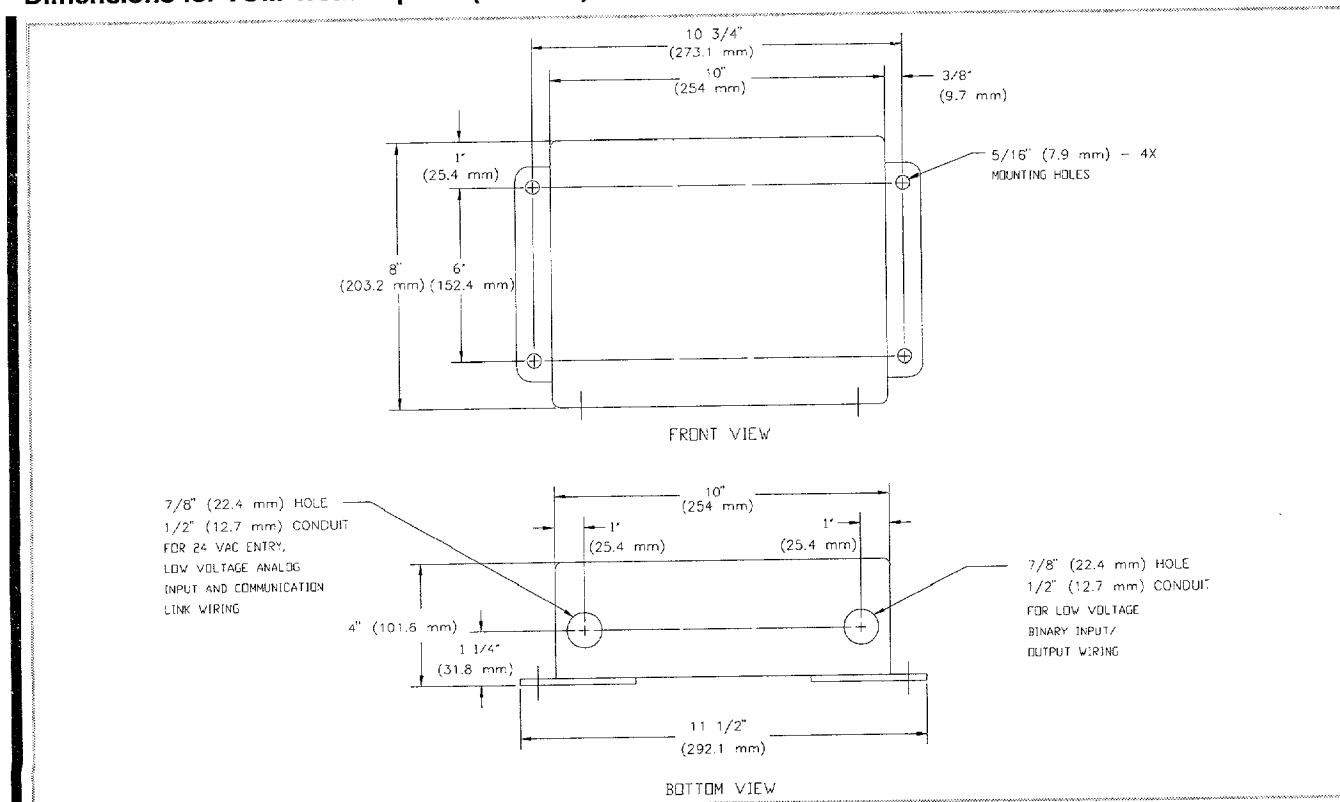

Figure 5
Dimensions for TCM Weatherproof (NEMA 4) Enclosure



AC Power Wiring

Power Supply

A dedicated 24 VAC, 30 VA minimum transformer is required to power the TCM. Multiple TCMs can be powered from a single, large 24 VAC transformer. Transformers should be sized for 30 VA per TCM. The TCM circuits are low voltage and recognized by UL as NEC Class II.

CAUTION: *The TCM 24 VAC power supply must not be used to power any devices other than the TCM(s). This could result in malfunction of the TCM due to electrical noise.*

The TCM requires 3-wire service with a nominal voltage of 24 VAC and a utilization range of 20 to 30 VAC. It is recommended that 16 AWG wire and metal conduit be used. AC power wiring must not be run in the same conduit with low voltage wiring. All wiring must comply with the National Electric Code and local codes.

WARNING: *Disconnect power external to the unit before making power connections to prevent injury or death from electrical shock.*

Note: *24 VAC power wiring must be rated for 194° F (90° C) for extended ambient and weatherproof TCMs.*

AC Power Connections

On the standard and extended ambient TCM, the 24 VAC line must enter the cabinet on the top left. On the weatherproof TCM, the 24 VAC line must enter the cabinet on the bottom left. Figures 3, 4, and 5 show the 24 VAC conduit entry holes. Connect the 24 VAC line to the unit at TB1, located in the upper left corner of the circuit board, as shown in Figure 6. Be sure to observe the polarity. Connect the 24 VAC hot wire to TB1-1, connect the common wire to TB1-2 (TB1-2 and TB1-3 are internally grounded), and connect the ground wire to TB1-3. Use copper conductors only.

WARNING: *Be sure to observe the polarity of the 24 VAC connections to prevent equipment damage and/or electrical shock hazard.*

AC Power Checkout

1. After the 24 VAC connections have been made at TB1, apply AC power by closing the circuit breaker for the transformer.
2. Measure the voltages at TB1. The voltage between TB1-1 and TB1-2 should be 20 to 30 VAC, between TB1-1 and TB1-3 (ground) should be 20 to 30 VAC, and between TB1-2 to TB1-3 (ground) should be 0 VAC.

WARNING: *Use care when measurements must be made with the power on to prevent injury or death from electrical shock.*

Communication Link Wiring

The communication link is for communication with a Trane BMS panel. Field wiring for the communication link must meet the following requirements.

1. All wiring must be in accordance with the National Electrical Code and local codes.
2. Recommended communication link wiring is Trane part number 40020-28F. This wire is plenum rated, 392° F (200° C), 18 gauge, shielded, twisted pair. Each conductor is stranded tinned copper.
3. The shield on the communication link wiring should be connected to the designated shield terminal at the Trane BMS panel. At the TCM, the shield should be spliced with the shield from the next section of communication link wiring and taped to prevent any connection between the shield and ground. At the last TCM on the link, the shield should be cut and taped back.
4. The maximum total wire length is 5,000 feet (1524 m) for the communication link. Refer to the chart on page 3.
5. The communication link wiring cannot pass between buildings.

6. At the TCM, the communication link wires must be connected to Terminals TB2-1 and TB2-2. Refer to Figure 6. There is no polarity requirement for this connection.
7. TCMs on the communication link can be connected in a "daisy chain" configuration.
8. Verify that the TCM address is properly set on DIP Switch SW1. Refer to the "DIP Switch Settings" section of this manual.
9. Refer to the appropriate Trane BMS Installation/Operation/Programming Manual for the communication link terminator connections.

Figure 6
TCM Field Wiring Connections

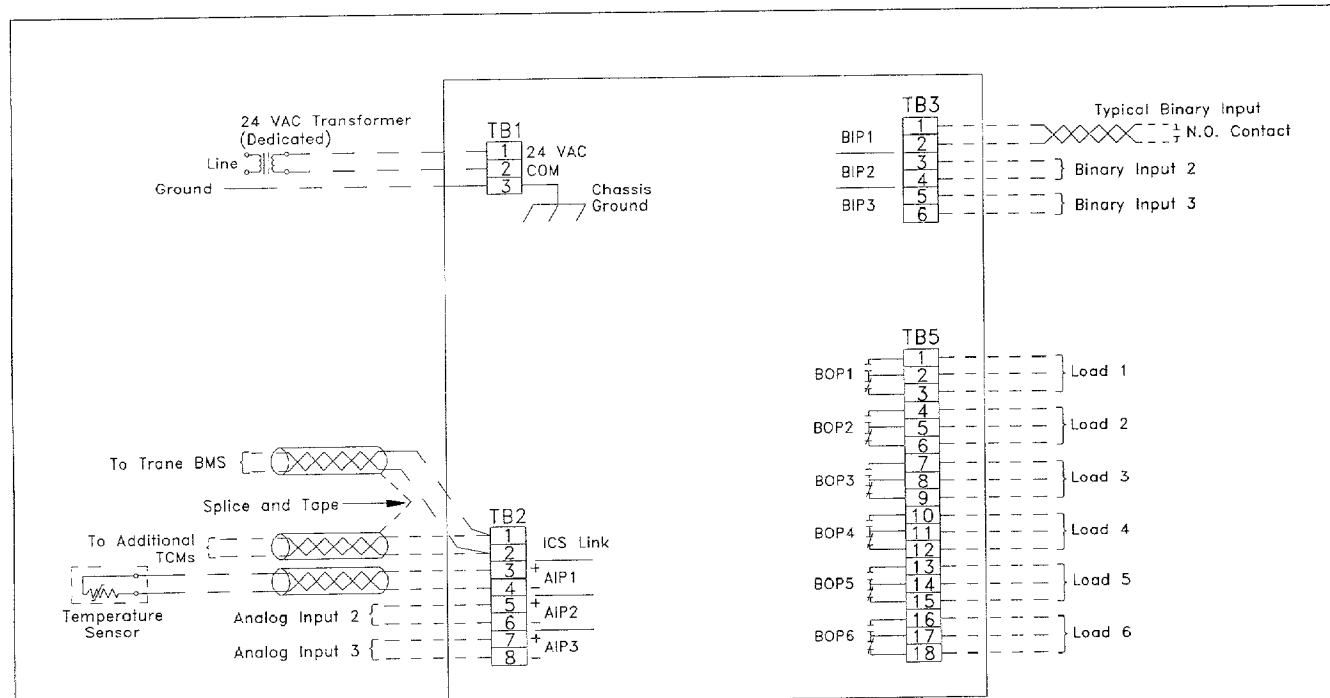

Customer Notes

1. Components and wiring shown dashed are furnished and installed by customer.
2. All customer wiring must be in accordance with national electric codes and local codes.
3. Voltage input required at TB1 is 20-30 VAC 60 Hz, 30 VA from a dedicated transformer (customer supplied). TB1-2 and TB1-3 are internally connected to chassis ground. Polarity must be observed when multiple TCMs are powered from the same transformer. 24 VAC from equipment control circuits cannot be used.
4. Refer to Note 10 for wire specifications. Shield must be cut back and taped to prevent any connection between the shield and either the TCM input terminals or ground. Shield wire must be connected to even numbered terminal of respective unit. Maximum binary input wiring distance is 1000 feet (305 m).
5. Binary inputs must be isolated, ungrounded contacts.
6. Refer to Note 10 for wire specifications. At the sensor, the shield must be cut back and taped. At the TCM input terminals, the shield must be connected to the even numbered terminal of the respective input. The maximum analog input wiring distance is 300 feet (91 m).
7. Binary output (BOP) relay contacts are rated at 30 VAC/VDC, 1 amp, 24 VA pilot duty.
8. The communication link is for communication with a Trane BMS. Refer to Note 10 for wire specifications. At the TCM, the shield should be spliced with the shield from the next section of communication link wiring and taped to prevent any connection between the shield and ground. The maximum total wire length is 5000 feet (1524 m) between buildings. Refer to the chart on page 3.
9. All customer connections on the TCM are cage clamp style terminals, suitable for bare wire terminations.
10. Recommended wire for binary inputs, analog inputs, and ICS link wiring is Trane part number 40020-28F. This wire is plenum rated, 392° F (200° C), 18 gauge, shielded, twisted pair. Each conductor is stranded tinned copper. Capacitance between conductors is 23 + or - 2 picofarads per foot (75.5 + or - 7 picofarads per meter).

DIP Switch Settings

DIP Switch S1 contains six switches for setting the TCM address and two switches for selecting the desired TCM program option. Refer to Figure 2 on page 6 for the location of Switch S1.

Up to 48 TCMs can be connected on a communication link, depending on the type of Trane BMS. The specific address of each TCM on the link must be set with S1 switches 1 through 6. No two TCMs can have the same address. Table 3 lists the DIP switch settings for each TCM address in a Version 7.0 through 11.0 Tracer 100 Series system, Table 4 lists the DIP switch settings for each TCM address in Version 12.0 and higher Tracer 100 Series systems and in Tracer Summit Systems, Table 5 lists the DIP switch settings for each TCM address in Tracker and ComforTrac systems, and Table 6 lists the DIP switch settings for each TCM address in a Tracer 1000 system.

Note: Tracer 100 Series panels (Version 12 and higher) allow TCM addresses from 01 through 64, even though only 48 TCMs can be connected to a single Tracer.

Table 2 lists the DIP switch settings for program selection. Each TCM has three program options and a special test mode. The test mode can be used for startup and checkout. S1 switches 7 and 8 must be set for the desired option prior to normal system operation. The Slave program operation allows generic control of the individual binary outputs by a Trane BMS. The two thermostat modes allow the TCM to be used as a standalone thermostat while receiving higher-level commands (such as OCCUPY/UNOCCUPY) from a Trane BMS.

**Table 2
TCM DIP Switch (S1) Settings
for Program Selection**

Program Option	S1 DIP Switch Setting	
	7	8
Slave	OFF	OFF
Air Conditioning Thermostat	OFF	ON
Heat Pump Thermostat	ON	OFF
Test Mode	ON	ON

**Table 3
DIP Switch (S1) Settings on TCM
for Addressing a Version 7.0 through 11.0
Tracer 100 Series System**

TCM Point Number	DIP Switch Settings					
	1	2	3	4	5	6
25-01	OFF	ON	ON	ON	OFF	ON
25-02	ON	OFF	ON	ON	OFF	ON
25-03	OFF	OFF	ON	ON	OFF	ON
25-04	ON	ON	OFF	ON	OFF	ON
25-05	OFF	ON	OFF	ON	OFF	ON
25-06	ON	OFF	OFF	ON	OFF	ON
25-07	OFF	OFF	OFF	ON	OFF	ON
25-08	ON	ON	ON	OFF	OFF	ON
25-09	OFF	ON	ON	OFF	OFF	ON
25-10	ON	OFF	ON	OFF	OFF	ON
25-11	OFF	OFF	ON	OFF	OFF	ON
25-12	ON	ON	OFF	OFF	OFF	ON
25-13	OFF	ON	OFF	OFF	OFF	ON
25-14	ON	OFF	OFF	OFF	OFF	ON
25-15	OFF	OFF	OFF	OFF	OFF	ON
25-16	ON	ON	ON	ON	ON	OFF
25-17	OFF	ON	ON	ON	ON	OFF
25-18	ON	OFF	ON	ON	ON	OFF
25-19	OFF	OFF	ON	ON	ON	OFF
25-20	ON	ON	OFF	ON	ON	OFF
25-21	OFF	ON	OFF	ON	ON	OFF
25-22	ON	OFF	OFF	ON	ON	OFF
25-23	OFF	OFF	OFF	ON	ON	OFF
25-24	ON	ON	ON	OFF	ON	OFF
25-25	OFF	ON	ON	OFF	ON	OFF
25-26	ON	OFF	ON	OFF	ON	OFF
25-27	OFF	OFF	ON	OFF	ON	OFF
25-28	ON	ON	OFF	OFF	ON	OFF
25-29	OFF	ON	OFF	OFF	ON	OFF
25-30	ON	OFF	OFF	OFF	ON	OFF
25-31	OFF	OFF	OFF	OFF	ON	OFF
25-32	ON	ON	ON	ON	OFF	OFF
25-33	OFF	ON	ON	ON	OFF	OFF
25-34	ON	OFF	ON	ON	OFF	OFF
25-35	OFF	OFF	ON	ON	OFF	OFF
25-36	ON	ON	OFF	ON	OFF	OFF
25-37	OFF	ON	OFF	ON	OFF	OFF
25-38	ON	OFF	OFF	ON	OFF	OFF
25-39	OFF	OFF	OFF	ON	OFF	OFF
25-40	ON	ON	ON	OFF	OFF	OFF
25-41	OFF	ON	ON	OFF	OFF	OFF
25-42	ON	OFF	ON	OFF	OFF	OFF
25-43	OFF	OFF	ON	OFF	OFF	OFF
25-44	ON	ON	OFF	OFF	OFF	OFF
25-45	OFF	ON	OFF	OFF	OFF	OFF
25-46	ON	OFF	OFF	OFF	OFF	OFF
25-47	OFF	OFF	OFF	OFF	OFF	OFF
25-48	ON	ON	ON	ON	ON	ON

Note: (Version 7.0 through 11.0 only) 48 TCMs can be connected to a single Tracer 100 Series panel only if **no other** equipment is connected on that link. If any other equipment (such as VAV Command Units) is connected on the link, the number of TCMs is limited to 32. Refer to the appropriate Tracer Installation Manual for details.

Table 4
DIP Switch (S1) Settings on TCM for Addressing a
Version 12.0 and Higher Tracer 100 Series System
or a Tracer Summit System

Address Number	DIP Switch Settings					
	1	2	3	4	5	6
01	OFF	ON	ON	ON	ON	ON
02	ON	OFF	ON	ON	ON	ON
03	OFF	OFF	ON	ON	ON	ON
04	ON	ON	OFF	ON	ON	ON
05	OFF	ON	OFF	ON	ON	ON
06	ON	OFF	OFF	ON	ON	ON
07	OFF	OFF	OFF	ON	ON	ON
08	ON	ON	ON	OFF	ON	ON
09	OFF	ON	ON	OFF	ON	ON
10	ON	OFF	ON	OFF	ON	ON
11	OFF	OFF	ON	OFF	ON	ON
12	ON	ON	OFF	OFF	ON	ON
13	OFF	ON	OFF	OFF	ON	ON
14	ON	OFF	OFF	OFF	ON	ON
15	OFF	OFF	OFF	OFF	ON	ON
16	ON	ON	ON	ON	OFF	ON
17	OFF	ON	ON	ON	OFF	ON
18	ON	OFF	ON	ON	OFF	ON
19	OFF	OFF	ON	ON	OFF	ON
20	ON	ON	OFF	ON	OFF	ON
21	OFF	ON	OFF	ON	OFF	ON
22	ON	OFF	OFF	ON	OFF	ON
23	OFF	OFF	OFF	ON	OFF	ON
24	ON	ON	ON	OFF	OFF	ON
25	OFF	ON	ON	OFF	OFF	ON
26	ON	OFF	ON	OFF	OFF	ON
27	OFF	OFF	ON	OFF	OFF	ON
28	ON	ON	OFF	OFF	OFF	ON
29	OFF	ON	OFF	OFF	OFF	ON
30	ON	OFF	OFF	OFF	OFF	ON
31	OFF	OFF	OFF	OFF	OFF	ON
32	ON	ON	ON	ON	ON	OFF
33	OFF	ON	ON	ON	ON	OFF
34	ON	OFF	ON	ON	ON	OFF
35	OFF	OFF	ON	ON	ON	OFF
36	ON	ON	OFF	ON	ON	OFF
37	OFF	ON	OFF	ON	ON	OFF
38	ON	OFF	OFF	ON	ON	OFF
39	OFF	OFF	OFF	ON	ON	OFF
40	ON	ON	ON	OFF	ON	OFF
41	OFF	ON	ON	OFF	ON	OFF
42	ON	OFF	ON	OFF	ON	OFF
43	OFF	OFF	ON	OFF	ON	OFF
44	ON	ON	OFF	OFF	ON	OFF
45	OFF	ON	OFF	OFF	ON	OFF
46	ON	OFF	OFF	OFF	ON	OFF
47	OFF	OFF	OFF	OFF	ON	OFF
48	ON	ON	ON	ON	OFF	OFF
49	OFF	ON	ON	ON	OFF	OFF
50	ON	OFF	ON	ON	OFF	OFF
51	OFF	OFF	ON	ON	OFF	OFF
52	ON	ON	OFF	ON	OFF	OFF
53	OFF	ON	OFF	ON	OFF	OFF
54	ON	OFF	OFF	ON	OFF	OFF
55	OFF	OFF	OFF	ON	OFF	OFF
56	ON	ON	ON	OFF	OFF	OFF
57	OFF	ON	ON	OFF	OFF	OFF
58	ON	OFF	ON	OFF	OFF	OFF
59	OFF	OFF	ON	OFF	OFF	OFF
60	ON	ON	OFF	OFF	OFF	OFF
61	OFF	ON	OFF	OFF	OFF	OFF
62	ON	OFF	OFF	OFF	OFF	OFF
63	OFF	OFF	OFF	OFF	OFF	OFF
64	ON	ON	ON	ON	ON	ON

Table 5
DIP Switch (S1) Settings on TCM for
Addressing a Tracker or ComforTrac System

Address Number	DIP Switch Settings					
	1	2	3	4	5	6
01	OFF	ON	ON	ON	OFF	ON
02	ON	OFF	ON	ON	OFF	ON
03	OFF	OFF	ON	ON	OFF	ON
04	ON	ON	OFF	ON	OFF	ON
05	OFF	ON	OFF	ON	OFF	ON
06	ON	OFF	OFF	ON	OFF	ON
07	OFF	OFF	OFF	ON	OFF	ON
08	ON	ON	ON	OFF	OFF	ON
09	OFF	ON	ON	OFF	OFF	ON
10	ON	OFF	ON	OFF	OFF	ON
11	OFF	OFF	ON	OFF	OFF	ON
12	ON	ON	OFF	OFF	OFF	ON
Slave	ON	ON	ON	ON	OFF	OFF
Slave	OFF	ON	ON	ON	OFF	OFF

Table 6
DIP Switch (S1) Settings on TCM
for Addressing a Tracer 1000 System

Tracer 1000 TCM Address	DIP Switch Setting					
	1	2	3	4	5	6
1	OFF	ON	ON	ON	ON	ON
2	ON	OFF	ON	ON	ON	ON
3	OFF	OFF	ON	ON	ON	ON
4	ON	ON	OFF	ON	ON	ON
5	OFF	ON	OFF	ON	ON	ON
6	ON	OFF	OFF	ON	ON	ON
7	OFF	OFF	OFF	ON	ON	ON
8	ON	ON	ON	OFF	ON	ON
9	OFF	ON	ON	OFF	ON	ON
10	ON	OFF	ON	OFF	ON	ON
11	OFF	OFF	ON	OFF	ON	ON
12	ON	ON	OFF	OFF	ON	ON
13	OFF	ON	OFF	OFF	ON	ON
14	ON	OFF	OFF	OFF	ON	ON
15	OFF	OFF	OFF	OFF	ON	ON
16	ON	ON	ON	ON	OFF	ON
17	OFF	ON	ON	ON	OFF	ON
18	ON	OFF	ON	ON	OFF	ON
19	OFF	OFF	ON	ON	OFF	ON
20	ON	ON	OFF	ON	OFF	ON
21	OFF	ON	OFF	ON	OFF	ON
22	ON	OFF	OFF	ON	OFF	ON
23	OFF	OFF	OFF	ON	OFF	ON
24	ON	ON	ON	OFF	OFF	ON
25	OFF	ON	ON	OFF	OFF	ON
26	ON	OFF	ON	OFF	OFF	ON
27	OFF	OFF	ON	OFF	OFF	ON
28	ON	ON	OFF	OFF	OFF	ON
29	OFF	ON	OFF	OFF	OFF	ON
30	ON	OFF	OFF	OFF	OFF	ON
31	OFF	OFF	OFF	OFF	OFF	ON
32	ON	ON	ON	ON	ON	OFF
33	OFF	ON	ON	ON	ON	OFF
34	ON	OFF	ON	ON	ON	OFF
35	OFF	OFF	ON	ON	ON	OFF
36	ON	ON	OFF	ON	ON	OFF
37	OFF	ON	OFF	ON	ON	OFF
38	ON	OFF	OFF	ON	ON	OFF
39	OFF	OFF	OFF	ON	ON	OFF
40	ON	ON	ON	OFF	ON	OFF
41	OFF	ON	ON	OFF	ON	OFF
42	ON	OFF	ON	OFF	ON	OFF
43	OFF	OFF	ON	OFF	ON	OFF
44	ON	ON	OFF	OFF	ON	OFF
45	OFF	ON	OFF	OFF	ON	OFF
46	ON	OFF	OFF	OFF	ON	OFF
47	OFF	OFF	OFF	OFF	ON	OFF
48	ON	ON	ON	ON	OFF	OFF

Input/Output Wiring

I/O Wiring Requirements

Note: All input/output wiring must comply with applicable electrical codes. Metal conduit may be required by local codes when running wires for analog inputs, binary inputs, or binary outputs.

Use only stranded, tinned copper conductors for input/output wiring. Input/output terminals will accept one wire of 12 to 22 AWG or two wires of 18 to 22 AWG. Do not run input/output wires in the same conduit or wire bundle with any AC power wires other than TCM 24 VAC power.

CAUTION: Running input/output wires in the same conduit or wire bundle with any AC power wires other than TCM 24 VAC power could cause the TCM to malfunction due to electrical noise.

For the standard enclosure, the input/output wires can enter the cabinet through the conduit entry holes shown in Figure 3.

For the extended ambient enclosure, the input/output wires should enter the cabinet through the 7/8" (22 mm) conduit entry holes shown in Figure 4.

For the weatherproof NEMA 4 enclosure, the 24 VAC wiring, analog input wiring, and communication wiring should enter the cabinet through the 7/8" (22 mm) conduit entry hole on the lower left. Binary input/output wiring should enter through the 7/8" (22 mm) conduit entry hole on the lower right. Refer to Figure 5.

Note: Weatherproof conduit (such as "seal-tite") should be used to run wiring to the weatherproof NEMA 4 TCM.

Input/output wiring connections at the TCM are shown in Figure 6.

Analog Input (Temperature Sensor) Wiring

Make all connections according to job wiring diagrams and in compliance with national and local codes.

Twisted, shielded pair wire is required for all sensor wiring, and it is recommended that 18 AWG wire be used. Use only stranded, tinned copper conductors. Do not run sensor wires in the same conduit or wire bundle with any AC power wires other than TCM 24 VAC power.

CAUTION: Running sensor wires in the same conduit or wire bundle with any AC power wires other than TCM 24 VAC power could cause a malfunction due to electrical noise.

Note: The TCM is compatible with Trane thermistor temperature sensors only, with a range of -30° to 220° F (-34° to 104° C).

Table 8
Thermistor Temperature Sensor
Electrical Characteristics

Temperature (°F)	Temperature (°C)	Sensor Resistance (Ohms)
-30	-34	241,000
-20	-29	170,000
-10	-23	121,000
0	-18	88,000
10	-12	64,000
20	-7	47,000
30	-1	35,000
40	4	26,000
50	10	20,000
60	16	15,300
70	21	11,900
80	27	9,300
90	32	7,300
100	38	5,800
110	43	4,700
120	49	3,800
130	54	3,000
140	60	2,500
150	66	2,000
175	79	1,300
200	93	837
220	104	600

Table 7
Temperature Sensor Specifications

Ordering Number	Type of Sensor	Mounting Location	Dimensions (Inches)		Wiring Terminations
			Element	Enclosure	
4190-1087	Room Sensor	Wall	----	4 1/2" (114 mm) high, 2 3/4" (70 mm) wide, 1" (25 mm) deep	Screw Terminals
4190-1089	Room Sensor with Override "ON" Switch	Wall	----	4 1/2" (114 mm) high, 2 3/4" (70 mm) wide, 1" (25 mm) deep	Screw Terminals
4190-1086	Room Sensor with Override "ON" Switch and Setpoint Adjustment Knob	Wall	----	4 1/2" (114 mm) high, 2 3/4" (70 mm) wide, 1" (25 mm) deep	Screw Terminals
4190-1088	Room Sensor with Override "ON" and "CANCEL" Switches	Wall	----	4 1/2" (114 mm) high, 2 3/4" (70 mm) wide, 1" (25 mm) deep	Screw Terminals
4190-1090	Room Sensor with Override "ON" and "CANCEL" Switches & Setpoint Adjustment	Wall	----	4 1/2" (114 mm) high, 2 3/4" (70 mm) wide, 1" (25 mm) deep	Screw Terminals
4190-1063	Outside Air Sensor	North Wall of Building	3/4" (19 mm) Diameter, 5" (127 mm) Long	----	Two 18" (457 mm) Black Pigtail Leads

Note: The range of all thermistor temperature sensors listed in this table is -30° to 220° F (-34° to 104° C) when used with a TCM.

Figure 7
Room Sensor with Override “ON” Button, “CANCEL” Button, and Adjustment Knob

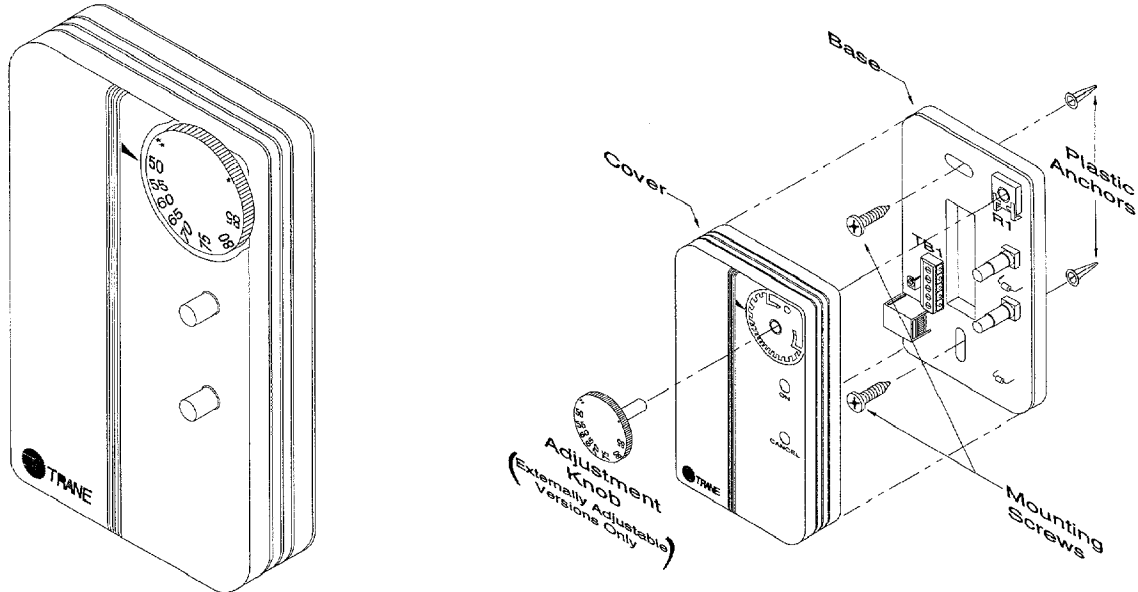

The lengths of wire runs should be limited to 300 feet (91 m) or less because of possible electrical noise problems with longer runs. Figure 12 shows the proper methods of making wiring connections at the TCM and at the sensor. The bare shield wire and the negative input lead should be connected at the negative terminal on the TCM. At the sensor, the bare shield wire and the shield should be cut back and taped to prevent any connection between the shield and ground.

CAUTION: *The shield must be taped at the sensor because any connection between the shield and ground will cause a malfunction.*

Note: *Be sure to observe polarity when connecting zone temperature sensors which have setpoint adjustment knobs. Refer to Figure 10.*

The temperature sensors listed in Table 7 have various mounting configurations and/or options. All of the sensors have the same electrical characteristics within the specified range. Table 7 lists the sensor specifications, while temperature sensor resistances are listed in Table 8.

The TCM will support new Trane sensors with the Timed Override “ON” and “CANCEL” buttons (AIP1 only).

Note: The override “CANCEL” feature may not be available on all Trane BMS controllers. Refer to the appropriate Trane BMS literature for compatibility details.

Pressing the “ON” override button on the zone temperature sensor during unoccupied periods will place the 2Heat/2Cool or Heat Pump TCM into the occupied mode for a period of time as edited at the associated BMS controller. The “CANCEL” button will revert the TCM to the unoccupied mode.

Room Sensor Mounting

Figure 7 shows the dimensions of a room temperature sensor, a room temperature sensor with override switch, a room temperature sensor with an adjustment knob, and a room temperature sensor with override switch and adjustment knob. Figures 8 through 10 are schematic diagrams showing the wiring connections for these sensors.

The room sensor can be mounted on a standard vertical outlet box. Mount the sensor on the wall in an area with good air circulation at an average temperature. Avoid mounting room sensors in areas subject to the following:

- drafts or "dead" spots behind doors or in corners;
- hot or cold air from ducts;
- radiant heat from the sun, or from appliances;
- concealed pipes and chimneys;
- unheated or uncooled surfaces behind the sensor, such as outside walls;
- airflows from adjacent zones or other units.

Figure 8
Schematic Diagram of Room Sensor

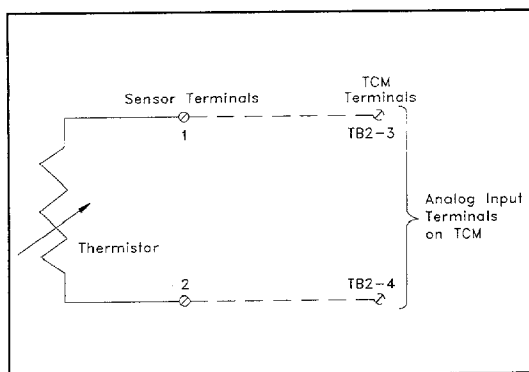

Figure 9
Schematic Diagram of Room Sensor with Override "ON" Switch

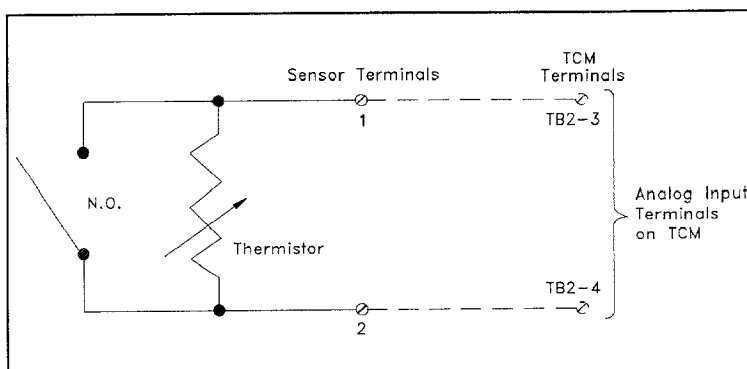

Figure 10
Schematic Diagram of Room Sensor with Override "ON" and "CANCEL" Switches and Adjustment Knob

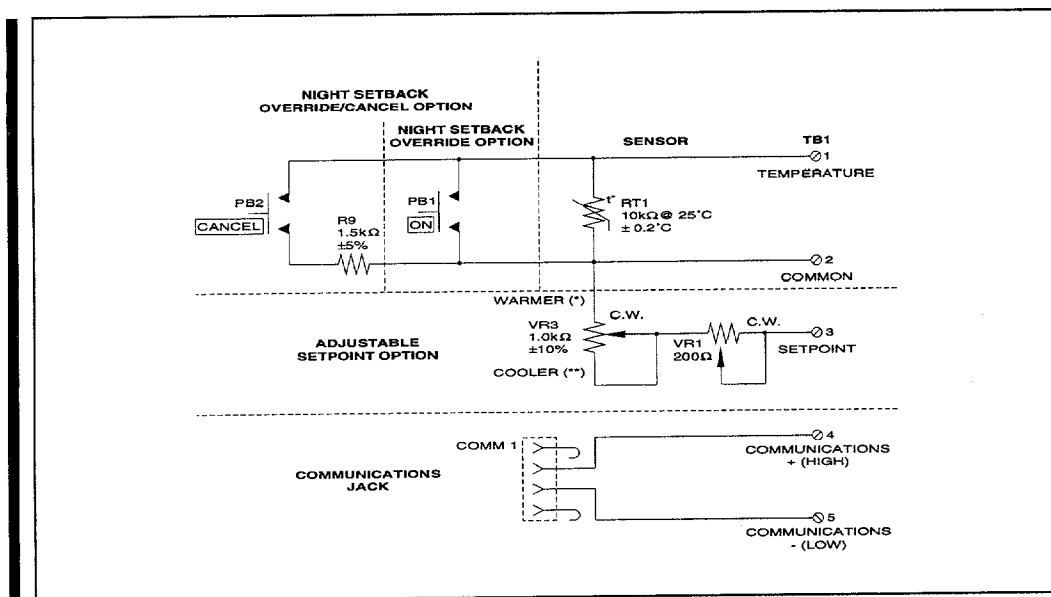
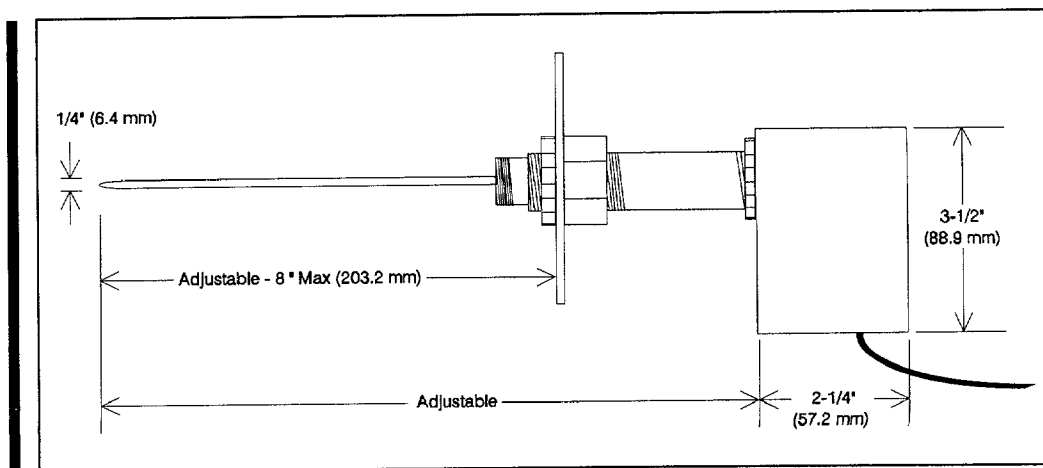

Figure 11
Duct/Immersion Temperature Sensor Dimensions



Duct/Immersion Sensor Mounting

The sensing probe of the duct temperature sensor (P/N 4190-1062) should be mounted in the duct where the airstream is typical of the air temperature. The sensing element is located within 1" (25 mm) of the end of the sensing probe. Use the sensor mounting plate as a template. Mounting screws are not provided. It is recommended that flexible conduit be used to connect the sensor enclosure to rigid conduit.

Figure 11 shows duct sensor dimensions. The schematic diagram in Figure 12 shows duct/immersion sensor wiring connections.

Figure 11
Schematic Diagram of an Outdoor Air Temperature Sensor

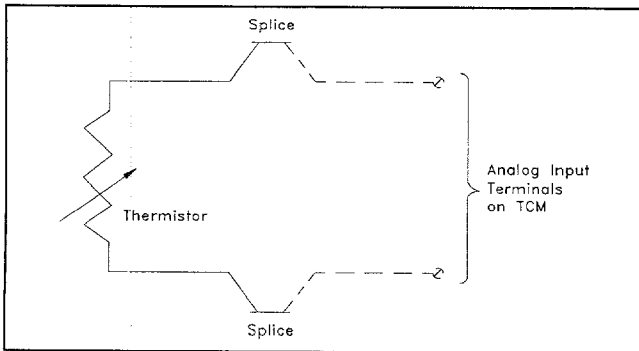

The duct temperature sensor can also serve as an immersion temperature sensor when used with an immersion well.

Sealed Sensor Mounting

Sealed temperature sensors (P/N 4190-1061) can be used for a variety of applications, such as strapped to a pipe, inserted in a well, etc. When strapped to a pipe, the pipe should be cleaned, heat transfer compound should be applied, and the sensor should be insulated from the ambient air. When inserted in a well, heat transfer compound should be applied.

The schematic diagram in Figure 12 shows sealed sensor wiring connections. The sealed sensor is 1/4" (6 mm) in diameter and 2-1/4" (57 mm) long.

Binary Input Wiring

Figure 6 illustrates typical binary input wiring connections and Figures 3, 4, and 5 show the conduit entry locations on the TCM. Binary inputs must be isolated and ungrounded contacts. The TCM provides 24 VAC, 12 mA for each binary input circuit. Twisted pair wire is required for binary inputs, and it is recommended that 18 AWG wire be used. If shielded wire is used, the shield should be cut back and taped at both ends to prevent any connection between the shield and either the TCM input terminals or ground.

CAUTION: Any connection between the shield and the TCM input terminals or ground could result in an equipment malfunction.

Figure 12
Wire Connections at the TCM TB2 Terminals and at the Sensor

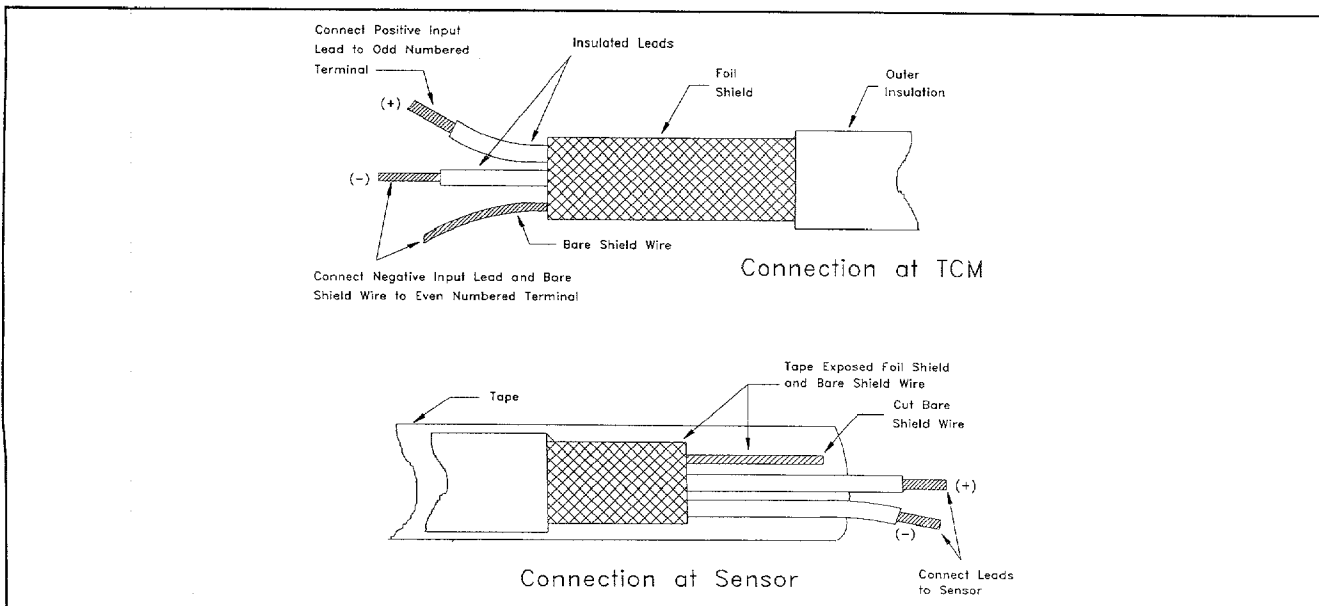

The lengths of wire runs should be limited to 1,000 feet (305 m) or less. This 1,000 foot (305 m) maximum should not be exceeded because of possible electrical noise problems with longer wire runs.

Binary inputs are connected to terminals on TB3. For example, binary input # 2 is connected to TB3-3 and TB3-4.

Binary Output Wiring

Note: Binary output wiring must be rated for 194° F (90° C) for extended ambient and weatherproof TCMs.

Figure 6 illustrates typical binary output wiring connections for TCMs in the "slave" mode, Figure 14 shows typical wiring connections for TCMs in the "air conditioning thermostat" mode, and Figure 15 illustrates typical wiring connections for TCMs in the "heat pump thermostat" mode. Figures 3, 4, and 5 show the conduit entry locations on the TCM. Each binary output on the TCM has a set of Form C (NO/NC) isolated, ungrounded contacts, rated for 24

VAC/VDC, 1 amp, 24 VA pilot duty. If the binary outputs are to interface with control circuits with higher voltage or amperage requirements, external 24 VAC coil pilot relays must be used to obtain the desired contact ratings.

Note: A separate 24 VAC source should be used to power these relays. Do not use the TCM 24 VAC supply to power external relays.

CAUTION: Use of the TCM 24 VAC supply to power external relays could result in equipment malfunction.

The binary output can be wired to either the normally open or the normally closed contacts. In the slave mode of Tracer 100 Series panels or Tracer 1000, the output relay operation can be configured for either NO or NC connections. In the thermostat modes, the output relay is energized when that particular output is to be turned on.

Figure 14
Example of Binary Output Wire Connections at TCMs used for Air Conditioning Thermostat

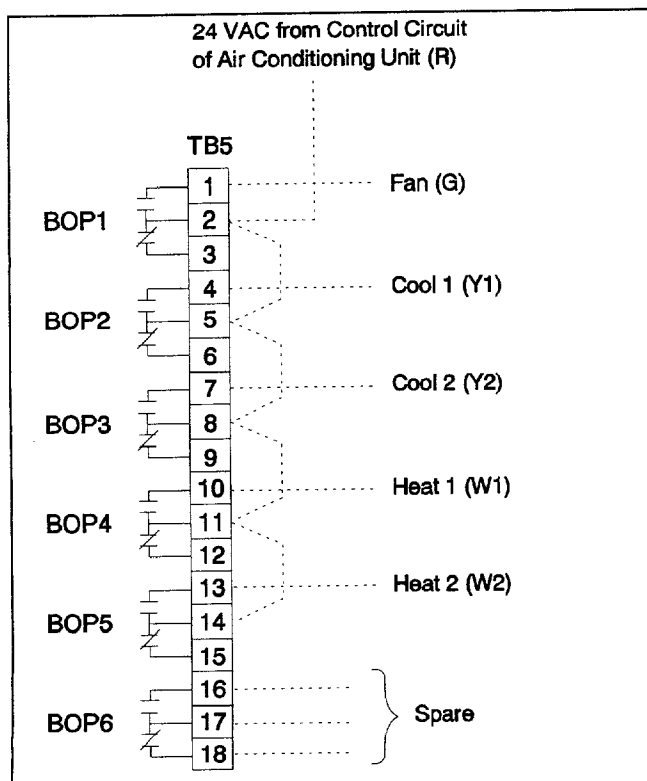
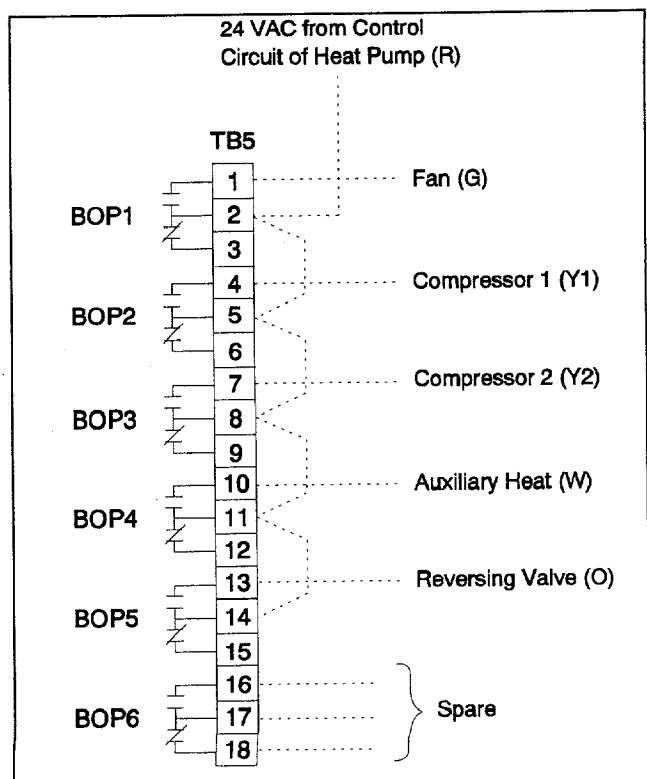

Figure 15
Example of Binary Output Wire Connections at TCMs used for Heat Pump Thermostat



TCM Input/Output Assignment Sheet

Job:	TCM:
Name <u>Jones Corp.</u>	Name <u>MAG R72</u>
Location <u>Anytown, USA</u>	Number <u>25-02</u>

TB1 AC Power Input

Wire No. or Color	TB1 Terminals	AC Power Connect.
<i>Black</i>	1	24 VAC
<i>White</i>	2	COM
<i>Green</i>	3	Ground

TB3 Binary Input

TB3 Wire No.	TB3 Terminals	Binary Input Name	Trane BMS Input Number
<i>901 Whi</i>	1	<i>Fan Status</i>	<i>19-01</i>
<i>901 Blk</i>	2		
<i>902 Whi</i>	3	<i>Comp Fail</i>	<i>19-02</i>
<i>902 Blk</i>	4		
<i>903 Whi</i>	5	<i>Dirty Filter</i>	<i>19-03</i>
<i>903 Blk</i>	6		

TB2 Communication/ Analog Input

Wire No.	TB2 Term.	Input Name	Trane BMS Input No.
	1	Comm. Link	---
	2		
<i>801 Whi</i>	3 +	<i>AIP #1: Zone Temp</i>	<i>18-03</i>
<i>801 Blk</i>	4 -		
<i>802 Whi</i>	5 +	<i>AIP #2: Zone Setpoint</i>	---
<i>802 Blk</i>	6 -		
<i>803 Whi</i>	7 +	<i>AIP #3: Discharge Temp</i>	<i>18-04</i>
<i>803 Blk</i>	8 -		

TB5 Binary Output

Trane BMS Output No.	Binary Output (BOP) Name	TB5 Terminals (Contacts)	Wire No.
---	BOP # 1: <i>Fan</i>	(N.O.) 1 (C) 2 (N.C.) 3	<i>G</i> <i>R</i>
---	BOP # 2: <i>Cool 1</i>	(N.O.) 4 (C) 5 (N.C.) 6	<i>Y1</i>
---	BOP # 3: <i>Cool 2</i>	(N.O.) 7 (C) 8 (N.C.) 9	<i>Y2</i>
---	BOP # 4: <i>Heat 1</i>	(N.O.) 10 (C) 11 (N.C.) 12	<i>W1</i>
---	BOP # 5: <i>Heat 2</i>	(N.O.) 13 (C) 14 (N.C.) 15	<i>W2</i>
<i>23-03</i>	BOP # 6: <i>Close OA Damper</i>	(N.O.) 16 (C) 17 (N.C.) 18	<i>Whi 301</i> <i>Blk 301</i>

S1 DIP Switch Settings: Enter ON or OFF

S1 DIP Switch Nos. (See Note)							
1	2	3	4	5	6	7	8
<i>ON</i>	<i>OFF</i>	<i>ON</i>	<i>ON</i>	<i>OFF</i>	<i>ON</i>	<i>OFF</i>	<i>ON</i>

NOTE: S1-1 thru S1-6 = TCM Address
S1-7 and S1-8 = Program Selection

TCM Input/Output Assignment Sheet

Job:
 Name _____
 Location _____

TCM:
 Name _____
 Number _____

TB1 AC Power Input

Wire No. or Color	TB1 Terminals	AC Power Connect.
	1	24 VAC
	2	COM
	3	Ground

TB3 Binary Input

TB3 Wire No.	TB3 Terminals	Binary Input Name	Trane BMS Input Number
	1		
	2		
	3		
	4		
	5		
	6		

TB2 Communication/ Analog Input

Wire No.	TB2 Term.	Input Name	Trane BMS Input No.
	1	Comm. Link	
	2		
	3 +	AIP # 1:	
	4 -		
	5 +	AIP # 2:	
	6 -		
	7 +	AIP # 3:	
	8 -		

TB5 Binary Output

Trane BMS Output No.	Binary Output (BOP) Name	TB5 Terminals (Contacts)	Wire No.
	BOP # 1:	(N.O.)	1
		(C)	2
		(N.C.)	3
	BOP # 2:	(N.O.)	4
		(C)	5
		(N.C.)	6
	BOP # 3:	(N.O.)	7
		(C)	8
		(N.C.)	9
	BOP # 4:	(N.O.)	10
		(C)	11
		(N.C.)	12
	BOP # 5:	(N.O.)	13
		(C)	14
		(N.C.)	15
	BOP # 6:	(N.O.)	16
		(C)	17
		(N.C.)	18

S1 DIP Switch Settings: Enter ON or OFF

S1 DIP Switch Nos. (See Note)							
1	2	3	4	5	6	7	8

NOTE: S1-1 thru S1-6 = TCM Address
 S1-7 and S1-8 = Program Selection

Installation Checklist

Complete this checklist as the unit is installed to verify that all recommended installation procedures are accomplished before the unit is started. This checklist does not replace the detailed instructions provided in the manual. Read the entire manual carefully to become familiar with the installation procedures before installing the unit.

Shipment

- TCM inspected for shipping damage and claim filed, if necessary.

Unit Location

- TCM installed in environment that meets temperature and humidity requirements.
- TCM securely mounted on wall or other mounting location.
- Proper clearances around TCM.

AC Power Wiring

- Field installed AC power wiring complies with all applicable codes.
- 24 VAC line from dedicated transformer connected to TCM at TB1 with the proper polarity.
- Voltage measured at TB1-1 to TB1-2 is 20 to 30 VAC, TB1-1 to TB1-3 is 20 to 30 VAC, and TB1-2 to TB1-3 is 0 VAC.

Input/Output Wiring

- Field installed input/output wiring complies with all applicable codes.
- Sensors are installed with twisted, shielded pair wiring.
- Binary inputs are installed with twisted pair wiring; shield taped, if used.
- Binary outputs are properly wired, and a separate 24 VAC power supply is provided for external relays, if used.
- Binary outputs can be manually controlled using Test Mode.
- TCM Input/Output Assignment Sheet filled out.

Communication Wiring

- Field installed communications wiring complies with all applicable codes.
- Trane BMS communication link wiring connected to TCM at TB2-1 and TB2-2.
- Communication link wire shields spliced at TCM and taped.
- Trane BMS communication link wiring connected to proper terminals at Trane BMS panel.
- TCM DIP Switch S1 properly set for TCM address and program option.

Operation

Important: Refer to the appropriate manuals for the various Trane BMS products for details of system operation in each type of system.

TCM Output Control

The TCM has six binary outputs which can either be controlled by a Trane BMS (slave mode) or by the TCM (thermostat modes). These program modes are selected by setting DIP switches S1-7 and S1-8 on the TCM. Refer to Figure 2 for switch S1 location and to Table 2 for switch settings.

Slave Mode

When the "slave" program option on the TCM is selected, the Trane BMS directly controls the TCM output points. In the slave mode, if the TCM loses communication with the Trane BMS for more than 15 minutes, it will return all outputs to their de-energized states.

Thermostat Modes

When one of the "thermostat" program options on the TCM is selected, the TCM monitors its zone temperature sensor and controls its outputs similar to a conventional wall thermostat. Through a Trane BMS, the operator can select thermostat control based either on 1) zone setpoints downloaded to its memory from the Trane BMS, or 2) a single setpoint from a space sensor-mounted setpoint adjustment knob.

Note: In either thermostat mode, the TCM can be used to provide thermostat control prior to Trane BMS installation. The TCM will operate in the occupied mode (with continuous fan) using either factory programmed setpoints (Heat = 71° F (22° C), Cool = 74° F (23° C)) or a setpoint knob (if installed) until the Trane BMS is installed. If the setpoint knob is used, the factory default Heating High Limit = 95° F (35° C) and Cooling Low Limit = 40° F (4° C).

On powerup, the TCM will wait 2 minutes or until a Trane BMS downloads control commands before controlling its outputs.

Table 9
TCM Operation in the Air Conditioning Thermostat Mode

	Idle Cool (Note 1)	Cool 1	Cool 2	Idle Heat (Note 2)	Heat 1	Heat 2
Fan	Note 3	X	X	Note 3	Note 4	Note 4
Cool 1		X	X			
Cool 2			X			
Heat 1					X	X
Heat 2						X

X = Relay Energized, Blank = Relay De-energized

Note 1: "Idle Cool" is the operating condition when the zone (TCM) is in the cooling mode but not actively cooling.

Note 2: "Idle Heat" is the operating condition when the zone (TCM) is in the heating mode but not actively heating.

Note 3: OFF if the fan mode is AUTO; ON if the fan mode is ON. In the Unoccupied Mode, the fan mode is AUTO.

Note 4: ON if fan operation is selected; OFF if fan control is by external thermostat.

Table 10
TCM Operation in the Heat Pump Thermostat Mode

	Idle Cool (Note 1)	Cool 1	Cool 2	Idle Heat (Note 2)	Heat 1	Heat 2	Heat 3 (Aux. Heat)	Emergency Heat
Fan	Note 3	X	X	Note 3	X	X	X	X
Compressor 1		X	X		X	X	X	
Compressor 2			X			X	X	
Auxiliary Heat							X	X
Reversing Valve	X	X	X					

X = Relay Energized, Blank = Relay De-energized

Note 1: "Idle Cool" is the operating condition when the zone (TCM) is in the cooling mode but not actively cooling.

Note 2: "Idle Heat" is the operating condition when the zone (TCM) is in the heating mode but not actively heating.

Note 3: OFF if the fan mode is AUTO; ON if the fan mode is ON. In the Unoccupied Mode, the fan mode is AUTO.

Operation

If the TCM is designated as an "air conditioning thermostat", binary outputs 1 through 5 provide standalone control of:

1. Fan
2. Cooling stage 1
3. Cooling stage 2
4. Heating stage 1
5. Heating stage 2

During heating operation in the air conditioning thermostat mode, the fan can either be controlled by the TCM or by an external plenum thermostat. This option is selected through the Trane BMS.

If the TCM is designated as a "heat pump thermostat", binary outputs 1 through 5 provide standalone control of:

1. Fan
2. Compressor 1
3. Compressor 2
4. Auxiliary heat
5. Reversing valve

In both the "air conditioning thermostat" and "heat pump thermostat" modes, the TCM provides minimum ON and OFF timer protection for each of the five binary outputs controlled by the thermostat programs. The thermostat control also provides time delays to improve the control performance.

IMPORTANT: *Because of the software timers for control and equipment protection, the TCM may not respond instantly to setpoint changes.*

In both thermostat modes, binary output # 6 is a spare which is available for "slave" control by the Trane BMS.

In both thermostat modes, if the TCM loses communication with the Trane BMS for more than 15 minutes, it will default to occupied operation, and binary output # 6 will return to the de-energized state.

Table 9 on page 23 describes the operation of TCM binary outputs in the air conditioning thermostat mode. Table 10 on page 23 describes the operation of TCM binary outputs in the heat pump thermostat mode.

TCM Input Monitoring

Temperature Inputs

The TCM has three thermistor-type analog temperature inputs, each compatible with a timed override switch mounted on the sensor. The analog inputs may be individually calibrated through a Trane BMS. The inputs have a range of -30° F to 220° F (-34° to 104° C). Optional temperature sensors include:

- Room sensor
- Room sensor with override switch
- Room sensor with override switch and zone setpoint adjustment and TOV cancel switch (AIP1 only)

If the TCM is used as a thermostat, the first analog input must be used for the zone temperature sensor. The second analog input can be used for the optional setpoint adjustment knob or for a spare temperature sensor. The third analog input is used for a spare temperature sensor.

Note: *In the slave mode, all 3 inputs must be thermistor type temperature sensors.*

In the thermostat modes, the TCM uses the zone sensor and setpoint inputs to perform the thermostatic control. The values of these inputs, as well as the spare input, are transmitted to the Trane BMS. In the slave mode, the TCM does not utilize the temperature inputs for control, but merely transmits the values to the Trane BMS.

Binary Inputs

The TCM has three binary inputs, each providing a 24 VAC, 12 mA signal to monitor isolated ungrounded contacts. In either the slave or thermostat modes, the status of any binary input is not utilized by the TCM for control, but merely transmitted to the Trane BMS.

Two values for each binary input are sent to the Trane BMS: the current ON/OFF status and a momentary closure indicator which is stored by the TCM until read by the Trane BMS. The current ON/OFF status will only change if the input changes for 2 continuous seconds. The momentary ON status will detect a 1 second closure.

Setpoint Adjustment (Thermostat Mode Only)

The occupied and unoccupied heating/cooling setpoints are stored in the TCM memory and are maintained through power interruptions of any duration. These setpoints are adjustable from a Trane BMS, and the occupied setpoints are also adjustable at the zone sensor using the optional setpoint adjustment knob.

When adjusted from the Trane BMS, the Occupied Heating Setpoint and Occupied Cooling Setpoint can be set anywhere between 40° F (4° C) and 95° F (35° C). The heating setpoint can be set less than, greater than, or equal to the cooling setpoint.

When a zone sensor setpoint adjustment knob is used, the selected value is used for both the heating and cooling setpoints.

A "high heating" setpoint adjustment limit (default 95° F (35° C)) and a "low cooling" setpoint adjustment limit (default 40° F (4° C)) can be set from the Trane BMS. These limits apply to both the setpoint adjustment knob and to a Trane BMS.

If setpoint adjustment is enabled (factory default = Enable) and the setpoint source fails (i.e., setpoint knob fail or Comm loss to Trane BMS), the TCM will use factory-programmed setpoints of Cool = 74° F (23° C), and Heat = 71° F (22° C).

LED Operation

During normal operation, the nine LED's will perform as follows.

Status - The STATUS LED will come on solid during self-diagnostics checks at startup (power-up). If the diagnostics are successful, the LED will flash at regular intervals. If this LED fails to light or stays lit continuously after startup, service is required.

TX - The transmit (TX) LED will flash when the TCM is transmitting data on the communications link.

RX - The receive (RX) LED will flash when the TCM is receiving data on the communications link.

K1 through K6 - The binary output status LED's will be ON when the associated binary output is energized.

Maintenance

Test Mode

CAUTION: Lock out equipment controlled by the TCM before entering the Test Mode to prevent inadvertent control of the equipment during test procedures.

Important: Be sure to record the normal operating settings of the S1 DIP switches and return the switches to these settings when the tests are completed.

The Test Mode allows the serviceman to check the operation of the TCM by 1) manually turning binary outputs on and off and 2) observing the status of analog and binary inputs.

Note: The TCM will not communicate with a Trane BMS while in the Test Mode.

To put the TCM in the Test Mode:

1. Lock out equipment controlled by the TCM before entering the Test Mode to prevent inadvertent control of the equipment during test procedures.
2. Record the normal operating settings of the S1 DIP switches. The switches should be returned to these settings when the tests are completed.
3. Move S1 switches 7 and 8 to the ON position. Refer to Figure 2 and Table 2.

Binary Output Checks

The Test Mode changes the functions of the six address DIP switches (S1-1 through S1-6). While these switches determine the TCM address during normal operation, in the Test Mode they directly control the six TCM binary outputs.

If switch S1-1 is turned ON, the binary output # 1 relay will be energized and the K1 LED will turn on within approximately five seconds. When the switch is turned OFF, the relay will be de-energized and the K1 LED will turn off. Switches S1-2 through S1-6 control binary output relays 2 through 6 (and LED's K2 through K6) in the same manner.

This enables the operator to verify that both the switch and the relay are operating properly. It can also be used to test equipment connected to the relay. For example, to verify that the TCM is properly controlling a fan, the corresponding DIP switch can be used to start and stop the fan.

Analog and Binary Input Checks

In the Test Mode, the STATUS LED can be used to monitor the status of TCM analog inputs and binary inputs. Refer to Figure 2 for the location of this LED.

The flash sequence of the STATUS LED will show in order the status of Analog Inputs 1, 2, and 3, followed by the status of Binary Inputs 1, 2, and 3. These flashes will occur at approximately one second intervals. There will be a short pause between each complete test sequence to indicate the start of a new flash sequence.

A binary input will produce a short flash if the input contacts are open and a longer flash if the contacts are closed.

An analog input will produce one of the following STATUS LED flashes:

1. A short flash if the sensor is open or has a resistance of greater than 18,600 ohms. (18,600 ohms corresponds to about 52° F (11° C)).
2. A long flash if the sensor is shorted or has a resistance of less than 4,700 ohms. (4,700 ohms corresponds to about 110° F (43° C)).
3. A double flash if the resistance is between 18,600 and 4,700 ohms. (The resistance of the sensor at room temperature is about 10,000 ohms.)

Known resistances can be connected in place of the sensor(s) to verify TCM analog input operation. An ohmmeter can be used to verify that each sensor is wired correctly. Refer to Table 8 for temperature sensor electrical characteristics.

Important: *Be sure to set the S1 DIP switches for normal operation when the Test Mode checks have been completed.*

Communications Link Check

The transmit (TX) and receive (RX) LEDs can be viewed while the TCM is communicating over the communications link, to verify that the TCM is transmitting and receiving data.

The RX LED will flash whenever there is communication activity on the link, such as between the Trane BMS and other devices on the link.

The TX LED will flash only when the TCM is responding to a request for its specific address.

If neither LED flashes, it is likely that a wiring problem exists, or the Trane BMS could be turned OFF or disconnected.

If the RX LED flashes, but the TX LED does not light (after a 2 minute interval), the TCM could be improperly addressed or the Trane BMS may not be programmed properly.