

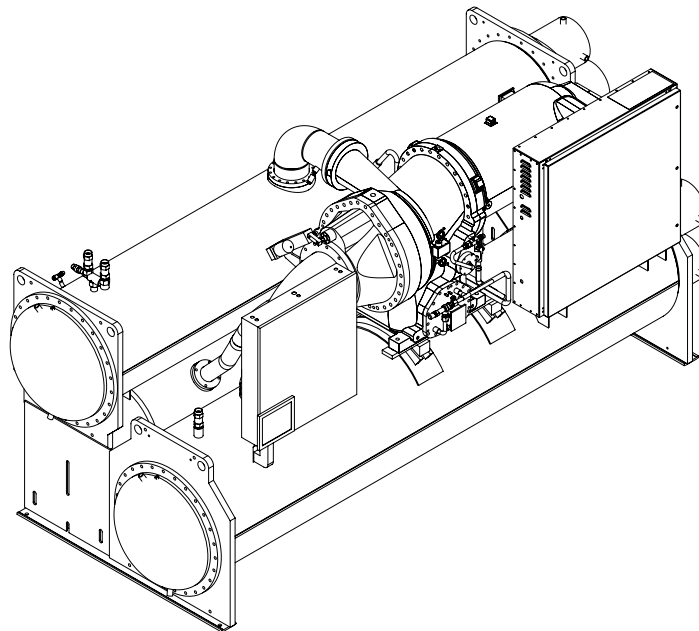

TRANE®

Installation Operation Maintenance Manual

Gear-Driven Centrifugal Water-Cooled Liquid Chillers with AdaptiView Controls



Unit Model
CVGF 400-1000 Ton Units
(50 and 60 Hz)

X39641150010

CVGF-SVX03B-EN

Copyright

© 2016 Trane All rights reserved

This document and the information in it are the property of Trane and may not be used or reproduced in whole or in part, without the written permission of Trane. Trane reserves the right to revise this publication at any time and to make changes to its content without obligation to notify any person of such revision or change.

Trademarks

Trane, the Trane logo, are trademarks of Trane in the United States and other countries. All other brands and products referenced in this document are acknowledged to be the trademarks or registered trademarks of their respective holders.

Warnings and Cautions

Warnings and cautions are provided in appropriate places throughout this document:

NOTICE: Warnings and Cautions appear at appropriate sections throughout this literature. Read these carefully.

⚠ WARNING: Indicates a potentially hazardous situation which, if not avoided, could result in death or serious injury.

⚠ CAUTION: Indicates a potentially hazardous situation which, if not avoided, may result in minor or moderate injury. It may also be used to alert against unsafe practices.

CAUTION: Indicates a situation that may result in equipment or property-damage only accidents.

Environmental Concerns!

Scientific research has shown that certain man-made chemicals can affect the earth's naturally occurring stratospheric ozone layer when released to the atmosphere. In particular, several of the identified chemicals that may affect the ozone layer are refrigerants that contain Chlorine, Fluorine and Carbon (CFCs) and those containing Hydrogen, Chlorine, Fluorine and Carbon (HCFCs). Not all refrigerants containing these compounds have the same potential impact to the environment. Trane advocates the responsible handling of all refrigerants—including industry replacements for CFCs such as and HCFCs and HFCs.

Responsible Refrigerant Practices!

Trane believes that responsible refrigerant practices are important to the environment, our customers, and the air conditioning industry. All technicians who handle refrigerants must be certified. The Federal Clean Air Act (Section 608) sets forth the requirements for handling, reclaiming, recovering and recycling of certain refrigerants and the equipment that is used in these service procedures. In addition, some states or municipalities may have additional requirements that must also be adhered to for responsible management of refrigerants. Know the applicable laws and follow them.

Contents

General Information	4
Installation: Mechanical	46
Installation: Electrical	76
Base Loading Control Algorithm	87
Control System Components	90
Machine Protection and Adaptive Control	102
Unit Startup	112
Periodic Maintenance	116



General Information

Literature History

CVGF-SVX03B-EN
(March 2016)
This is a new manual.

About this manual

This manual describes proper installation of Model CVGF, 50 Hz and 60 Hz chillers with the AdaptiView Controls platform. See Figures 2 and 3 for an illustration of a CVGF Centrifugal Chiller with the AdaptiView Unit Control Panel. These chillers are equipped with microcomputer-based control systems. A careful review of this information along with the submittal package provided for the unit will assure that the chiller is correctly installed.

Operation and maintenance information for models CVGF are covered in this manual. This includes both 50 and 60 Hz. CVGF centrifugal chillers equipped with the Tracer AdaptiView Chiller Controller system.

A typical product description block is shown in the Manual.

Carefully review this information and follow the instructions given to successfully install operate and maintain a CVGF unit.

If mechanical problems do occur, contact a qualified service organization to ensure proper diagnosis and repair of the unit.

Unit Nameplate

When the unit arrives, compare all nameplate data with order, submittal and shipping information. A typical unit nameplate is shown in Figure 1.

The unit nameplate is located on the left side of the unit control panel.

Note: Trane starters are identified by a separate model number found on the starter.

Figure 1. Typical unit nameplate

MODEL: CVGF500							
MODEL NO:							
CVGF0500RA0U33809405C1B5C1C23A1A201E3AA0							
SERIAL NO:				S.O. NO:			
ELECTRICAL CHARACTERISTICS:							
RATED VOLTAGE:		380 VOLTS		50HZ		3PH	
NAMEPLATE NMKW:		338 kW					
VOLTAGE UTILIZATION RANGE:		345- 422 VAC					
MINIMUM CIRCUIT AMPACITY:		726 AMPS					
MAXIMUM FUSE:		1200 AMPS					
MAXIMUM CIRCUIT BREAKER		1200 AMPS					
MAXIMUM OVERLOAD TRIP:		617 AMPS					
		VOLTS-AC		HZ	PH	RLA	MAX LRAY
COMPRESSOR MOTOR		380		50	3	577	MAX LRAD 3286
OIL PUMP MOTOR		380		50	31.43 FLA		
OIL TANK HEATER		115		50	1000 WATTS TOTAL		
CONTROL CIRCUIT		115		50	1500 VA MAX		
WHEN MOTOR CONTROLLER PROVIDED BY OTHERS TRANE ENGINEERING SPEC. S6516-0360 APPLIES							
GENERAL CHARACTERISTICS:							
REFRIGERANT SYSTEM							
TO BE FIELD CHARGED		ACTUALLY CHARGED					
WITH 340 KG OF R-134A		WITH KG OF R-134A					
MAXIMUM REFRIGERANT WORKING PRESSURE							
HI SIDE 15.2 BAR		LOW SIDE 15.2 BAR					
FACTORY TEST PRESSURE							
HI SIDE 16.7 BAR		LOW SIDE 16.7 BAR					
FIELD LEAK TEST PRESSURE		5.17 BAR MAX.					
TESTED AT		BAR					
LEAK TEST AND CHARGING SPECIFICATION ARE SUPPLIED IN CONTROL PANEL (SERVICE LITERATURE MANUAL)							
MANUFACTURED UNDER ONE OR MORE OF THE FOLLOWING U.S. PATENTS: 4686834 4689967 4715190 5056032 5058031 5434738 5563489 5836382							
SERVICE LITERATURE INSTALLATION, OPERATION AND MAINTENANCE MANUAL: CVGF-SVN02C-EN AND CVGF-SVU02B-EN							
"FOR INSTALLATION REQUIREMENTS, USE ELECTRICAL CHARACTERISTICS NOT PRODUCT DESCRIPTION"							
PRODUCT DESCRIPTION:							
MODL CVGF	DSEQ A0	NTON 500	VOLT 380				
HRTZ 50	CPKW 338	CPIM 940	EVSZ 500				
EVBS C	EVTB TE25	EFLD WATE	EVWB NM15				
EVWP 2	EVCO FLGE	EVWA RERE	CDSZ 500				
CDBS C	CDTB TE28	CFLD WATE	CDWB NM15				
CDCO FLGE	CDWA RERE	ORSZ 23	AGLT UL				
SPKGEXPS	INSL YES	OPTM YES	WVUO YES				
TRMM TRMS	LCLD CLDC	LANG ENGL	SRTY USTR				
SRRL 952	PNCO DISC	TEST PTR3					

Commonly Used Abbreviations

For convenience, a number of abbreviations are used throughout this manual. These are listed alphabetically below, along with a translation of each:

ASME = American Society of Mechanical Engineers

ASHRAE = American Society of Heating, Refrigerating and Air Conditioning Engineers

BAS = Building Automation System

CDBS = Condenser Bundle Size

CDSZ = Condenser Shell Size

AdaptiView=Tracer AdaptiView Controller

CWR = Chilled Water Reset

CWR' = Chilled Water Reset Prime

DFTL = Design Delta-T at FullLoad (for example, the difference between entering and leaving chilled water temperatures)

ADPV = AdaptiView™

ELWT = Evaporator Leaving Water Temperature

ENT = Entering Chilled Water Temperature

EXOP = Extended Operation

GBAS = Generic Building Automation Interface

GPM = Gallons-per-minute

HLUV = High Lift Unloading Valve.

Hp = Horsepower

HVAC = Heating, Ventilating, and Air Conditioning

IE = Internally-Enhanced Tubes

IPC = Interprocessor Communication

LCD = Liquid Crystal Display

LED = Light Emitting Diode

LLID = Low Level Intelligent Device (Sensor, Pressure Transducer, or Input/output UCP module)

MAR = Machine Shutdown Auto Restart (Non-Latching where chiller will restart when condition corrects itself.)

MMR = Machine Shutdown Manual Restart (Latching where chiller must be manually reset.)

UC800 = Main Processor

PFCC = Power Factor Correction Capacitor

PID = Proportional Integral Derivative

PSID = Pounds-per-Square-Inch (differential pressure)

PSIG = Pounds-per-Square-Inch (gauge pressure)

ODT = Outdoor Temperature

OPST = Operating Status Control

RLA = Rated Load Amps

RTD = Resistive Temperature Device Tracer

AdaptiView= Controls Platform used on this Chiller



General Information

TRMM = Tracer
Communications
UCP = Unit Control Panel

Figure 2. General CVGF unit component

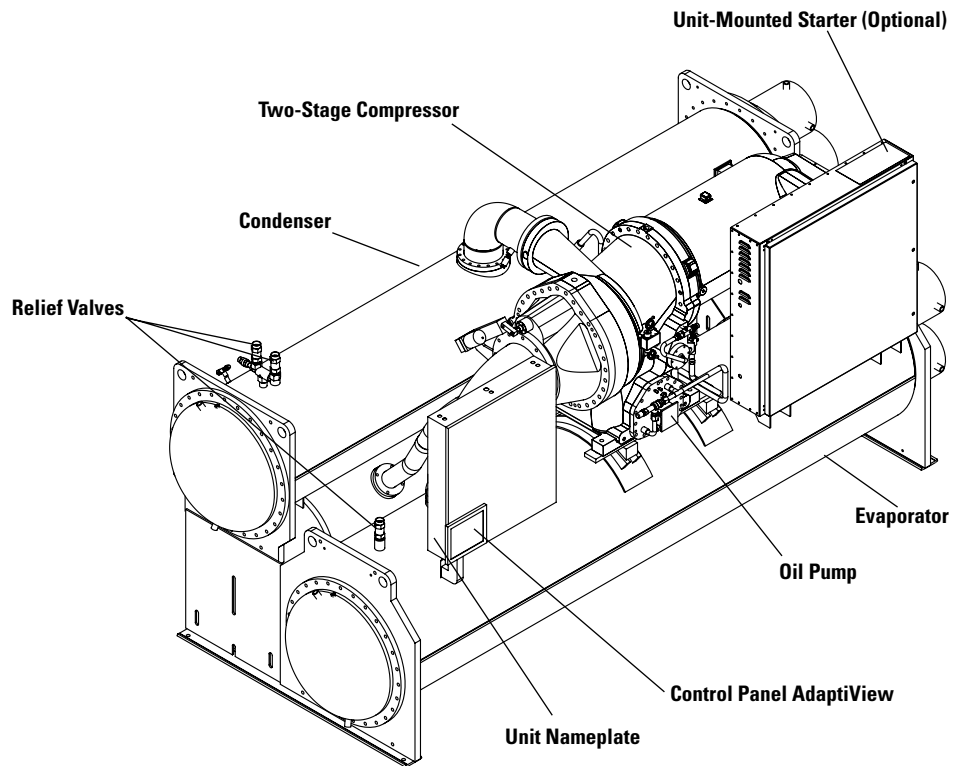
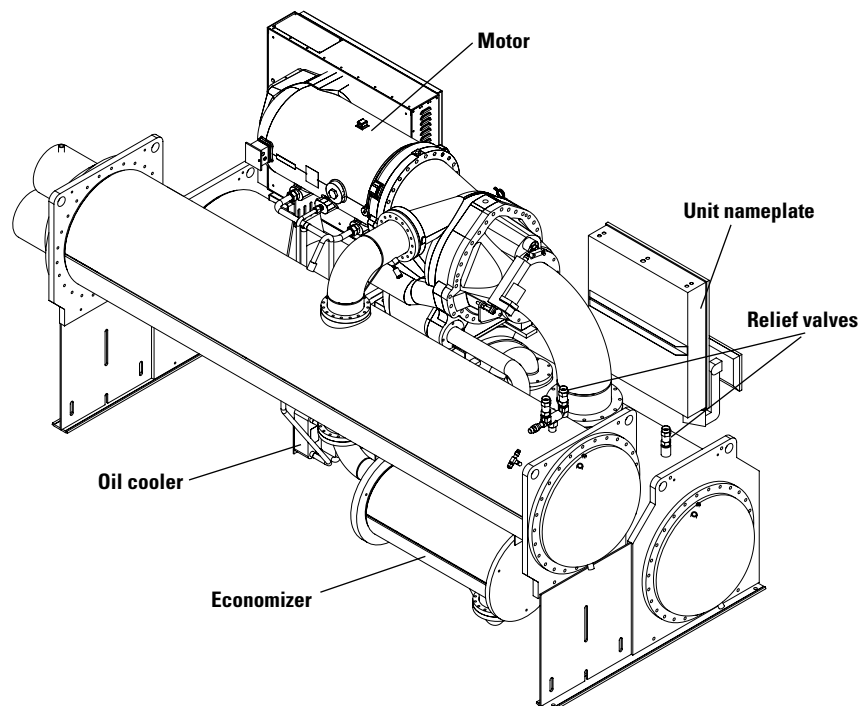

Figure 3. Component location for typical CVGF unit (back view)





General Information

Unit Nameplates

The CVGF unit nameplate (Figure 2 shows the nameplate location) is applied to the exterior surface of the control panel. The starter nameplate is located inside the starter panel.

The unit nameplate provides the following information:

- Unit model
 - Unit serial number
 - Unit device number - identifies unit electrical requirements - Lists correct operating charges of HFC-134a and lubrication oil - Lists unit test pressures and maximum working pressures
- The starter nameplate provides the following information:

- Panel model number
- Rated load amps
- Voltage
- Electrical characteristics starter type, wiring
- Options included

Unit Inspection

When the unit is delivered, verify that it is the correct unit and that it is properly equipped.

Inspect all exterior components for visible damage. Report any apparent damage or material shortage to the carrier and make a "unit damage" notation on the carrier's delivery receipt. Specify the extent and type of damage found and notify the appropriate Trane Sales Office.

Do not proceed with installation of a damaged unit without sales office approval.

Inspection Checklist

To protect against loss due to damage incurred in transit, complete the pre-commissioning checklist, which can be obtained from your Trane representative.

- Inspect the individual pieces of the shipment before accepting the unit. Check for obvious damage to the unit
- Inspect the unit for concealed damage as soon as possible after delivery and before it is stored. Concealed damage must be reported within 10 days after receipt.
- If concealed damage is discovered, stop unpacking the shipment. Do not remove damaged material from the receiving location. Take photos of the damage, if possible. The owner must provide reasonable evidence that the damage did not occur after delivery.
- Notify the Trane sales representative and arrange for repair. Do not repair the unit, however, until damage is inspected by the transportation

Loose Parts Inventory

The loose parts items ship in the motor junction box for units without a unit-mounted starter, or in the starter panel for units equipped with a unit-mounted starter. This includes the isolation pads, extra oil filter, and any optional optional factory-shipped items.

Unit Description

The CVGF units are singlecompressor, gear-type, watercooled liquid chillers designed for installation indoors. Each unit is a completely assembled, hermetic package that is factory piped, wired, leak-tested, dehydrated, oil-charged, and tested for proper control operation before shipment.

Note: high-voltage starters are not unit-mounted before shipment.

Figure 2 and Figure 3 show a typical CVGF unit and its components. Water inlet and outlet openings are covered before shipment. The oil tank is factory-charged with 15 gallons (56.8L) of Trane Oil 37 and a holding charge of 5 psig (34 kPa) of dry nitrogen at 70°F (21°C).



General Information

Model number digits are selected and assigned in accordance with the following definitions using the typical model number example shown below:

CVGF0500HA0C31609005B1B5B1C2306G4A1E2CC0A0CL

C = (1st digit)

V = (2nd digit) Hermetic Centrifugal Compressor

G = (3rd digit) Gear Drive

F = (4th digit) Development sequence

0500 = (5th, 6th, 7th, and 8th digit) Nominal compressor tonnage

0400 = 400 tons

0500 = 500 tons

0650 = 650 tons

0800 = 800 tons

1000 = 1000 tons

SSSS = Special

H = (9th digit) Unit Voltage

D = 380V-60 Hz

F = 460V-60 Hz

H = 575V-60 Hz

N = 4160V-60 Hz

P = 3300V-60 Hz

R = 380V-50 Hz

T = 400V-50 Hz

U = 415V-50 Hz

V = 3300V-50 Hz

X = 6600V-60 Hz

Z = 6600V-50 Hz

S = Special

A0 = (10th and 11th digit) Design Sequence

C = (12th digit) Control Enclosure

C = Standard Control Enclosure

S = Special

316 = (13th, 14th, and 15th digit) Compressor Motor Power (kw)

221 = 221 CPKW

254 = 254 CPKW

285 = 285 CPKW

316 = 316 CPKW

357 = 357 CPKW

401 = 401 CPKW

240 = 240 CPKW

266 = 266 CPKW

301 = 301 CPKW

338 = 338 CPKW

374 = 374 CPKW

430 = 430 CPKW

444 = 444 CPKW

484 = 484 CPKW

511 = 511 CPKW

532 = 532 CPKW

574 = 574 CPKW

594 = 594 CPKW

641 = 641 CPKW

674 = 674 CPKW

719 = 719 CPKW

751 = 751 CPKW

808 = 808 CPKW

SSS = Special

0900 = (16th, 17th, 18th, and 19th digit) Compressor Impeller Cutback

0880 CPIM

0890 CPIM

0900 CPIM

0910 CPIM

0920 CPIM

0930 CPIM

0940 CPIM

0950 CPIM

0960 CPIM

0970 CPIM

0980 CPIM

0990 CPIM

1000 through 1510 = Cutback is the same as the FCOD for impeller cutback

SSSS = Special

5 = (20th digit) Evaporator Shell Size

1 = 1000 ton evaporator

5 = 500 ton evaporator

7 = 700 ton evaporator

S = Special

B = (21st digit) Evaporator Tube Bundle

A = Small bundle

B = Medium bundle

C = Large bundle

D = Extra large bundle

S = Special

1 = (22nd digit) Evaporator Tubes

1 = .75 diameter .025 wall internally enhanced cu tube

2 = 1.00 diameter .025 wall internally enhanced cu tube

S = Special

B = (23rd digit) Evaporator Waterbox

B = 150 PSI Non-Marine - 2 pass

C = 150 PSI Non-Marine - 3 pass

D = 150 PSI Marine - 2 pass

E = 150 PSI Marine - 3 pass

H = 300 PSI Marine - 2 pass

J = 300 PSI Marine - 3 pass

L = 300 PSI Non-Marine - 2 pass

M = 300 PSI Non-Marine - 3 pass

S = Special

5 = (24th digit) Condenser Shell Size

1 = 1000 ton condenser

5 = 500 ton condenser

7 = 700 ton condenser

S = Special



General Information

B = (25th digit) Condenser Tube Bundle

- A = Small bundle
- B = Medium bundle
- C = Large bundle
- D = Extra large bundle
- S = Special

1 = (26th digit) Condenser Tubes

- 1 = .75 diameter .028 wall internally enhanced cu tube
- 2 = 1.00 diameter .028 wall internally enhanced cu tube
- 3 = .75 diameter .035 wall 90/10 cu/ni tube
- 4 = .75 diameter .028 wall titanium tube
- 5 = .75 diameter .025 wall internally enhanced cu tube
- 6 = 1.00 diameter .025 wall internally enhanced cu tube
- S = Special

C = (27th digit) Condenser Waterbox

- A = 150 PSI Marine - 2 pass
- C = 150 PSI Non-Marine - 2 pass
- E = 300 PSI Marine - 2 pass
- G = 300 PSI Non-Marine - 2 pass
- S = Special

23 = (28th and 29th digit) Orifice Series

- 13 Orifice series
- 14 Orifice series
- 15 Orifice series
- 16 Orifice series
- 17 Orifice series
- 18 Orifice series
- 19 Orifice series
- 20 Orifice series
- 22 Orifice series
- 23 Orifice series
- 25 Orifice series
- 27 Orifice series
- 28 Orifice series
- 30 Orifice series
- 31 Orifice series
- 33 Orifice series
- 35 Orifice series
- 38 Orifice series
- 40 Orifice series
- 42 Orifice series
- 44 Orifice series
- 47 Orifice series
- 49 Orifice series
- 51 Orifice series
- 56 Orifice series
- SS = Special

0 = (30th digit) Factory Installed Insulation

- 0 = None
- A = Standard thickness
- B = Extra thickness

1 = (31st digit) Control: Operating Status

0 = None

1 = Operating Status

G = (32nd digit) Control: Generic BAS

0 = None

G = Generic BAS

4 = (33rd digit) Tracer Communication Interface

0 = None

4 = COMM 4

5 = COMM 5

6 = MODBUS (AdaptiView Only)

7 = BACnet (AdaptiView Only)

A = (34th digit) Chilled Water Reset - Outdoor Air Temperature Sensor

0 = None

A = Chilled Water Reset – With Outdoor Air Temp Sensor

1 = (35th digit) Control: Extended Operation

0 = None

1 = Extended Operation

E = (36th digit) Language

E = English

F = French

G = German

T = Italian

P = Spanish

S = Special

2 = (37th digit) Motor Frame Size

2 = 400 Frame

3 = 440E Frame

4 = 5000 Frame

S = Special

C = (38th digit) Impeller Rim Diameter 1st Stage

A = 9.5 Rim diameter

B = 10.0 Rim diameter

C = 10.6 Rim diameter

D = 11.1 Rim diameter

E = 11.6 Rim diameter

F = 9.8 Rim diameter

G = 10.4 Rim diameter

H = 11.0 Rim diameter

J = 11.7 Rim diameter

K = 12.7 Rim diameter

L = 13.5 Rim diameter

M = 14.3 Rim diameter

N = 15.1 Rim diameter

S = Special

C = (39th digit) Impeller Rim Diameter 2nd Stage

A = 9.5 Rim diameter

B = 10.0 Rim diameter

C = 10.6 Rim diameter

D = 11.1 Rim diameter

E = 11.6 Rim diameter



General Information

- F = 9.8 Rim diameter
- G = 10.4 Rim diameter
- H = 11.0 Rim diameter
- J = 11.7 Rim diameter
- K = 12.7 Rim diameter
- L = 13.5 Rim diameter
- M = 14.3 Rim diameter
- N = 15.1 Rim diameter
- S = Special
- 0 = (40th digit) Special Options**
- 0 = None
- S = Special option
- A = (41st digit) Starter Type**
- A = Star-Delta - unit mounted
- B = Solid State - unit mounted
- C = Star-Delta - remote mounted
- E = X-line full volt - remote mounted
- F = Autotransformer - remote mounted
- G = Primary reactor - remote mounted
- M = Solid State Floor Mounted
- N = Solid State Wall Mounted
- R = Customer supplied
- 0 = (42nd digit) Additional Pressure Vessel Compliance**
- 0 = None
- N = Non-destructive Examination for China
- K = KHK Japanese pressure vessel code
- C = (43rd digit) Control: Condenser Refrigerant Pressure**
- 0 = None
- C = Condenser Refrigerant Pressure
- L = (44th digit) Manufacturing Location**
- L = La Crosse, Wisconsin
- T = Tai Cang, China
- 0 = (45th digit) Agency**
- 0 = UL
- 1 = CE
- 2 = GB

Service Model Numbers –Solid State Motor Starter

An example of a typical Solid State " IT " starter model number is:

CVSR0035FAA01EA0E1

Model Number Digit Identification - Model number digits are selected and assigned in accordance with the following definitions using the model number example shown above.

C = (1st digit)

V = 2nd digit)

S = (3rd digit)

R = (4th digit) Development Sequence

R = Cutler Hammer Solid State " IT " starter for gear drive centrifugal chillers with AdaptiView controls

0035 = (5th, 6th, 7th, and 8th digit) Starter Size

Use Rated Load Amps (RLA) value

F = (9th digit) Unit Voltage

D = 380V-60Hz-3Ph

F = 460V-60Hz-3Ph

H = 575V-60Hz-3Ph

R = 380V-50Hz-3Ph

T = 400V-50Hz-3Ph

U = 415V-50Hz-3Ph

S = Special

A = (10th digit) Design Sequence

A = Original Design

A = (11th digit) Starter Type

B = Unit Mounted

M = Remote Floor Mounted

N = Remote Wall Mounted

S = Special

0 = (12th digit) Connection Type

0 = Terminal Block

1 = Disconnect Switch - Non-Fused

2 = Circuit Breaker

3 = Circuit Breaker Current Limiting

4 = Circuit Breaker High Interrupt Cap

5 = Circuit Breaker Higher Interrupt Cap

S = Special

1 = (13th digit) Agency Listing

1 = UL & cUL Listed (Standard on all units)

2 = CE

E = (14th Digit) Power Factor Correction Capacitor

0 = None

D = 25 KVAR

E = 30 KVAR

F = 35 KVAR

G = 40 KVAR

H = 45 KVAR

J = 50 KVAR

K = 60 KVAR

L = 70 KVAR

M = 75 KVAR



General Information

N = 80 KVAR
P = 90 KVAR
R = 100 KVAR
T = 120 KVAR
U = 125 KVAR
V = 150 KVAR
S = Special
A = (15th Digit) Ground Fault Protection
0 = None
A = Ground Fault Protection
S = Special
0 = (16th digit) Special Options
0 = None
S = Special Options (See Sales Order)
E = (17th digit) Literature Language
E = English
F = French
G = German
P = Spanish
T = Italian
S = Special
1 = (18th digit) Oil Pump Starter Circuit
1 = 1 HP Oil Pump Motor
2 = 1.5 HP Oil Pump

Service Model Numbers - Wye-delta Motor Starter

An example of a typical chiller starter model number is:

CVSN0035FAA01EA0E1

Model Number Digit Identification - Model number digits are selected and assigned in accordance with the following definitions using the model number example shown above.

C = (1st digit)

V = 2nd digit)

S = (3rd digit)

N = (4th digit) Development Sequence

N = Cutler-Hammer electrical-mechanical starter for gear drive centrifugal chillers with AdaptiView controls

0035 = (5th, 6th, 7th, and 8th digit) Starter Size

F = (9th digit) Unit Voltage

D = 380V-60Hz-3Ph

F = 460V-60Hz-3Ph

H = 575V-60Hz-3Ph

R = 380V-50Hz-3Ph

T = 400V-50Hz-3Ph

U = 415V-50Hz-3Ph

S = Special

A = (10th digit) Design Sequence

A = Original Design

A = (11th digit) Starter Type

A = Star-Delta - Unit Mounted

C = Star-Delta - Remote Mounted

S = Special

0 = (12th digit) Connection Type

0 = Terminal Block

1 = Disconnect Switch - Non-Fused

2 = Circuit Breaker

3 = Circuit Breaker Current Limiting

4 = Circuit Breaker High Interrupt Cap

5 = Circuit Breaker Higher Interrupt Cap

S = Special

1 = (13th digit) Agency Listing

1 = UL & cUL Listed (Standard on all units)

2 = CE.

E = (14th Digit) Power Factor Correction Capacitor

0 = None

D = 25 KVAR

E = 30 KVAR

F = 35 KVAR

G = 40 KVAR

H = 45 KVAR

J = 50 KVAR

K = 60 KVAR

L = 70 KVAR

M = 75 KVAR

N = 80 KVAR

P = 90 KVAR

R = 100 KVAR

T = 120 KVAR

U = 125 KVAR

V = 150 KVAR

S = Special

A = (15th Digit) Ground Fault Protection

0 = None

A = Ground Fault Protection

S = Special

0 = (16th digit) Special Options

0 = None

S = Special Options (See Sales Order)

E = (17th digit) Literature Language

E = English

F = French

G = German

P = Spanish

T = Italian

S = Special

1 = (18th digit) Oil Pump Starter Circuit

1 = 1 HP Oil Pump Motor

2 = 1.5 HP Oil Pump Motor



General Information

Installation Overview

For convenience, Table 1 summarizes responsibilities that are typically associated with the CVGF chiller installation process.

Table 1. Installation responsibility chart for CVGF units

Requirement	Trane-supplied, Trane-installed	Trane-supplied, Field-installed	Field-supplied, Field-installed
Rigging			Safety chains Clevis connectors Lifting beam equipment, skates, rollers, and other lifting operations
Isolation		Isolation pads Spring isolators	Spring isolators
Electrical	Circuit breakers or non-fused disconnects (optional) Unit-mounted starter (optional)	Remote-mounted starter (optional) Temperature sensor (optional outdoor air)	Circuit breakers or fusible disconnects (optional) Terminal lugs Ground connection(s) Jumper bars BAS wiring (optional) IPC wiring Control voltage wiring Chilled-water-pump contactor and wiring Condenser-water-pump contactor and wiring Optional relays and wiring
Water piping		Flow switches (may be field-supplied)	Thermometers Water flow pressure gauges Isolation and balancing valves water piping Vent and drain valves Pressure relief valves (for water boxes as required)
Pressure Relief	Relief valves		Vent line and flexible connector
Insulation	Insulation (optional)		Insulation

Refer to the Mechanical and Electrical sections of this manual for detailed instructions.

- Locate and maintain the loose parts such as, isolators, bulb wells, temperature sensors, flow sensors or other factory-ordered field-installed options, as required. Loose parts are located in the starter panel if equipped with a unit-mounted starter. If not equipped with a unit-mounted starter, loose parts are shipped in the motor junction box.
- Install the unit on a foundation with flat support surfaces, level within 1/4" (6 mm) and of sufficient strength and mass to support the chiller operating weight. Place the manufacturer-supplied isolation-pad assemblies under the unit.
- Install the unit per the instructions outlined in the Mechanical Installation section.
- Complete all water piping and electrical connections.

Note: Field piping must be arranged and supported to avoid stress on the equipment. It is strongly recommended that the piping contractor provide at least 3 feet (914 mm) of clearance between the preinstallation piping and the planned location of the unit. This will allow for the proper fit upon arrival of the unit at the installation site. All necessary piping adjustments can be made at that time.

- Where specified, supply and install valves in the water piping, upstream and downstream of the evaporator and condenser water boxes, in order to isolate the shells for maintenance and to balance and trim the system.
- Supply and install flow switches or equivalent devices in both the chilled-water piping and the condenser-water piping. Interlock each switch with the proper pump starter, to ensure that the unit can only operate when water flow is established.

Note: reference graphs 1-16 in the Installation Mechanical section for proper water flow.

- Supply and install taps for thermometers and a pressure gauge manifold in the water piping, adjacent to the inlet and outlet connections of both the evaporator and the condenser.
- Supply and install drain valves on each water box.
- Supply and install vent cocks on each water box.
- Where specified, supply and install strainers ahead of all pumps and automatic modulating valves.
- Supply and install refrigerant pressure-relief piping from the pressure-relief valve to the atmosphere.
- If necessary, supply enough HFC-134a refrigerant (1 pound = .45 kg) and dry nitrogen (75 psig = 517 kPa maximum) for leak testing.
- Evacuate the unit to less than 500 microns (0.5 mm Hg) or according to local code.
- Charge with refrigerant 134a.
- Go over the pre-commissioning check sheet and ensure that all items have been completed.
- Start the unit under the supervision of a qualified service technician.



General Information

Table 2. General data: 400 and 500 ton units

Nominal Tonnage	400	400	400	400	500	500	500	500
Tube Outside Diameter (inch)	1.0	1.0	0.75	0.75	1.0	1.0	0.75	0.75
Evaporator Water Pass	Two	Three	Two	Three	Two	Three	Two	Three
Refrigerant Type	R134a	R134a	R134a	R134a	R134a	R134a	R134a	R134a
Refrigerant Charge - pounds (kg)	650 (295)	650 (295)	650 (295)	650 (295)	750 (295)	750 (295)	750 (295)	750 (295)
Oil Charge (gallon (l))	15 (56.8)	15 (56.8)	15 (56.8)	15 (56.8)	15 (56.8)	15 (56.8)	15 (56.8)	15 (56.8)
Overall Dimensions - Feet-Inch (mm)								
Length	15' - 10 13/16" (4800)	15' - 10 13/16" (4800)	15' - 10 13/16" (4800)	15' - 10 13/16" (4800)	15' - 10 13/16" (4800)	15' - 10 13/16" (4800)	15' - 10 13/16" (4800)	15' - 10 13/16" (4800)
Width	6' - 6 19/64" (1989)	6' - 6 19/64" (1989)	6' - 6 19/64" (1989)	6' - 6 19/64" (1989)	6' - 6 19/64" (1989)	6' - 6 19/64" (1989)	6' - 6 19/64" (1989)	6' - 6 19/64" (1989)
Height	6' - 10 1/2" (2096)	6' - 10 1/2" (2096)	6' - 10 1/2" (2096)	6' - 10 1/2" (2096)	6' - 10 1/2" (2096)	6' - 10 1/2" (2096)	6' - 10 1/2" (2096)	6' - 10 1/2" (2096)
Evaporator Inside Diameter	2' - 7 1/8" (791)	2' - 7 1/8" (791)	2' - 7 1/8" (791)	2' - 7 1/8" (791)	2' - 7 1/8" (791)	2' - 7 1/8" (791)	2' - 7 1/8" (791)	2' - 7 1/8" (791)
Evaporator Water Connection (NPS)	8" (203)	8" (203)	8" (203)	8" (203)	8" (203)	8" (203)	8" (203)	8" (203)
Condenser Inside Diameter	2' - 1 1/2" (3060)	2' - 1 1/2" (3060)	2' - 1 1/2" (3060)	2' - 1 1/2" (3060)	2' - 1 1/2" (3060)	2' - 1 1/2" (3060)	2' - 1 1/2" (3060)	2' - 1 1/2" (3060)
Condenser Nominal Connector Size (NPS)	10" (254)	10" (254)	10" (254)	10" (254)	10" (254)	10" (254)	10" (254)	10" (254)
Weight - pounds (kg) except Waterboxes								
Compressor/Motor	6220 (2821)	6220 (2821)	6220 (2821)	6220 (2821)	6220 (2821)	6220 (2821)	6220 (2821)	6220 (2821)
Evaporator	3948 (1791)	3948 (1791)	4228 (1918)	4228 (1918)	4193 (1902)	4193 (1902)	4568 (2072)	4568 (2072)
Condenser	2857 (1296)	2857 (1296)	3472 (1575)	3472 (1575)	3152 (1430)	3152 (1430)	3877 (1759)	3877 (1759)
Economizer	535 (243)	535 (243)	535 (243)	535 (243)	535 (243)	535 (243)	535 (243)	535 (243)
Starter Panel	500 (227)	500 (227)	500 (227)	500 (227)	500 (227)	500 (227)	500 (227)	500 (227)
Control Panel	70 (318)	70 (318)	70 (318)	70 (318)	70 (318)	70 (318)	70 (318)	70 (318)
Miscellaneous Item	2127 (965)	2127 (965)	2127 (965)	2127 (965)	2127 (965)	2127 (965)	2127 (965)	2127 (965)
Shipping Weight	17867 (8104)	17867 (8104)	17867 (8104)	17867 (8104)	17867 (8104)	17867 (8104)	17867 (8104)	17867 (8104)
Operating Weight	21460 (9734)	21460 (9734)	21460 (9734)	21460 (9734)	22564 (10235)	22564 (10235)	22564 (10235)	22564 (10235)
Operational Data								
Minimum Evaporator Flow in gpm (l/sec)	447 (28)	298 (20)	407 (25.6)	271 (17)	550 (34)	367 (23)	511 (32)	340 (21)
Maximum Evaporator Flow in gpm (l/sec)	1638 (103)	1092 (69)	1493 (94)	995 (63)	2018 (127)	1346 (85)	1873 (118)	124895 (79)
Minimum Condenser Flow in gpm (l/sec)	499 (31)	499 (31)	487 (31)	487 (31)	606 (38)	606 (38)	586 (37)	586 (37)
Maximum Condenser Flow in gpm (l/sec)	1831 (115)	1831 (115)	1786 (113)	1786 (113)	2221 (140)	2221 (140)	2148 (135)	2148 (135)

Table 2. General data: 400 and 500 ton units (continued)

Nominal Tonnage	400	400	400	400	500	500	500	500
Tube Outside Diameter (inch)	1.0	1.0	0.75	0.75	1.0	1.0	0.75	0.75
Evaporator Water Pass	Two	Three	Two	Three	Two	Three	Two	Three
Water Volume - 150 pound Waterboxes								
Evaporator Water Storage gallon (l)	101.7 (385)	101.49 (384)	95.7 (361)	95.4 (361)	117.2 (444)	116.9 (443)	111.2 (421)	110.9 (420)
Condenser Water Storage gallon (l)	112 (424)	112 (424)	110.4 (418)	110.4 (418)	127.8 (484)	127.8 (484)	125.0 (473)	125.0 (473)
Evaporator 2-pass Weight								
Supply - pound (kg)	304 (138)	304 (138)	304 (138)	304 (138)	304 (138)	304 (138)	304 (138)	304 (138)
Return - pound (kg)	337 (153)	337 (153)	337 (153)	337 (153)	337 (153)	337 (153)	337 (153)	337 (153)
Evaporator 3-pass Weight								
Supply - pound (kg)	314 (142)	314 (142)	314 (142)	314 (142)	314 (142)	314 (142)	314 (142)	314 (142)
Return - pound (kg)	332 (151)	332 (151)	332 (151)	332 (151)	332 (151)	332 (151)	332 (151)	332 (151)
Condenser 2-pass Weight								
Supply - pound (kg)	304 (138)	304 (138)	304 (138)	304 (138)	304 (138)	304 (138)	304 (138)	304 (138)
Return - pound (kg)	341 (155)	341 (155)	341 (155)	341 (155)	341 (155)	341 (155)	341 (155)	341 (155)
300 pound Waterboxes								
Evaporator Water Storage gallon (l)	101.9 (386)	101.6 (385)	95.9 (363)	95.6 (362)	117.4 (444)	117.0 (443)	111.4 (422)	111.1 (421)
Condenser Water Storage gallon (l)	112.3 (425)	112.3 (425)	110.6 (419)	110.6 (419)	128.0 (485)	128.0 (485)	125.3 (474)	125.3 (474)
Evaporator 2-pass Weight								
Supply - pound (kg)	427 (194)	427 (194)	427 (194)	427 (194)	427 (194)	427 (194)	427 (194)	427 (194)
Return - pound (kg)	446 (202)	446 (202)	446 (202)	446 (202)	446 (202)	446 (202)	446 (202)	446 (202)
Evaporator 3-pass Weight								
Supply - pound (kg)	448 (203)	448 (203)	448 (203)	448 (203)	448 (203)	448 (203)	448 (203)	448 (203)
Return - pound (kg)	448 (203)	448 (203)	448 (203)	448 (203)	448 (203)	448 (203)	448 (203)	448 (203)
Condenser 2-pass Weight								
Supply - pound (kg)	421 (191)	421 (191)	421 (191)	421 (191)	421 (191)	421 (191)	421 (191)	421 (191)
Return - pound (kg)	436 (198)	436 (198)	436 (198)	436 (198)	436 (198)	436 (198)	436 (198)	436 (198)



General Information

Table 3. General data: 650 ton units

Nominal Tonnage	650			
Tube Outside Diameter (inch)	1.0		0.75	
Evaporator Water Pass	Two	Three	Two	Three
Refrigerant Type	R134a	R134a	R134a	R134a
Refrigerant Charge - pounds (kg)	975 (442.3)	975 (442.3)	975 (442.3)	975 (442.3)
Oil Charge gallon (l)	15 (56.8)	15 (56.8)	15 (56.8)	15 (56.8)
Overall Dimensions - Feet-Inch (mm)				
Length	16' 4877	16' 4877	16' 4877	16' 4877
Width	6' - 9 3/4 (2076)	6' - 9 3/4 (2076)	6' - 9 3/4 (2076)	6' - 9 3/4 (2076)
Height	7' - 5 11/32" (2270)	7' - 5 11/32" (2270)	7' - 5 11/32" (2270)	7' - 5 11/32" (2270)
Evaporator Inside Diameter	3' - 1/4" (921)	3' - 1/4" (921)	3' - 1/4" (921)	3' - 1/4" (921)
Evaporator Water Connection (NPS)	10" (254)	8" (203)	10" (254)	8" (203)
Condenser Inside Diameter	2' - 1 1/2" (648)	2' - 1 1/2" (648)	2' - 1 1/2" (648)	2' - 1 1/2" (648)
Condenser Nominal Connector Size (NPS)	12" (300)	12" (300)	12" (300)	12" (300)
Weight - pounds (kg) except Waterboxes				
Compressor/Motor	6800 (3084)	6800 (3084)	6800 (3084)	6800 (3084)
Evaporator	5461 (2477)	5834 (2643)	5461 (2477)	5834 (2643)
Condenser	3937 (1786)	4763 (2161)	3937 (1786)	4763 (2161)
Economizer	799 (362)	799 (362)	799 (362)	799 (362)
Starter Panel	542 (246)	542 (246)	542 (246)	542 (246)
Control Panel	70 (318)	70 (318)	70 (318)	70 (318)
Miscellaneous Item	2745 (1245)	2745 (1245)	2745 (1245)	2745 (1245)
Shipping Weight	24140 (10950)	24140 (10950)	24140 (10950)	24140 (10950)
Operating Weight	28344 (12857)	28344 (12857)	28344 (12857)	28344 (12857)
Operational Data				
Minimum Evaporator Flow in gpm (l/sec)	625 (39)	417 (26)	566 (36)	378 (24)
Maximum Evaporator Flow in gpm (l/sec)	2501 (158)	1529 (97)	1493 (94)	995 (63)
Minimum Condenser Flow in gpm (l/sec)	682 (43)	682 (43)	668 (42)	668 (42)
Maximum Condenser Flow in gpm (l/sec)	2501 (158)	2501 (258)	2450 (155)	2450 (155)

Table 3. General data: 650 ton units (continued)

Nominal Tonnage	650			
Tube Outside Diameter (inch)	1.0		0.75	
Evaporator Water Pass	Two	Three	Two	Three
Water Volume - 150 pound Waterboxes				
Evaporator Water Storage gallon (l)	163.2 (618)	158.2 (599)	154.1 (583)	149.1 (564)
Condenser Water Storage gallon (l)	185.1 (701)	185.1 (701)	188.5 (714)	188.5 (714)
Evaporator 2-pass Weight				
Supply - pound (kg)	304 (138)	304 (138)	304 (138)	304 (138)
Return - pound (kg)	337 (153)	337 (153)	337 (153)	337 (153)
Evaporator 3-pass Weight				
Supply - pound (kg)	314 (142)	314 (142)	314 (142)	314 (142)
Return - pound (kg)	332 (151)	332 (151)	332 (151)	332 (151)
Condenser 2-pass Weight				
Supply - pound (kg)	304 (138)	304 (138)	304 (138)	304 (138)
Return - pound (kg)	341 (155)	341 (155)	341 (155)	341 (155)
300 pound Waterboxes				
Evaporator Water Storage gallon (l)	163.2 (618)	158.2 (599)	154.1 (583)	149.1 (564)
Condenser Water Storage gallon (l)	185.1 (701)	185.1 (701)	189.4 (717)	189.4 (717)
Evaporator 2-pass Weight				
Supply - pound (kg)	427 (194)	427 (194)	427 (194)	427 (194)
Return - pound (kg)	446 (202)	446 (202)	446 (202)	446 (202)
Evaporator 3-pass Weight				
Supply - pound (kg)	448 (203)	448 (203)	448 (203)	448 (203)
Return - pound (kg)	448 (203)	448 (203)	448 (203)	448 (203)
Condenser 2-pass Weight				
Supply - pound (kg)	421 (191)	421 (191)	421 (191)	421 (191)
Return - pound (kg)	436 (198)	436 (198)	436 (198)	436 (198)



General Information

Table 4. General data: 700 ton family

Nominal Tonnage	560	560	560	560	630	630	630	630
Tube Outside Diameter (inch)	1.0	1.0	0.75	0.75	1.0	1.0	0.75	0.75
Evaporator Water Pass	Two	Three	Two	Three	Two	Three	Two	Three
Refrigerant Charge - pounds (kg)	875 (397)	875 (397)	875 (397)	875 (397)	925 (420)	925 (420)	925 (420)	925 (420)
Oil charge - gallons (l)	15 (56.8)	15 (56.8)	15 (56.8)	15 (56.8)	15 (56.8)	15 (56.8)	15 (56.8)	15 (56.8)
Overall Dimensions - Feet-Inch (mm)								
Length	16'11" (5153)	16'11" (5153)	16'11" (5153)	16'11" (5153)	16'11" (5153)	16'11" (5153)	16'11" (5153)	16'11" (5153)
Width	6'10" (2075)	6'10" (2075)	6'10" (2075)	6'10" (2075)	6'10" (2075)	6'10" (2075)	6'10" (2075)	6'10" (2075)
Height	7'5" (2269)	7'5" (2269)	7'5" (2269)	7'5" (2269)	7'5" (2269)	7'5" (2269)	7'5" (2269)	7'5" (2269)
Evaporator Inside Diameter	36-1/4" (921)	36-1/4" (921)	36-1/4" (921)	36-1/4" (921)	36-1/4" (921)	36-1/4" (921)	36-1/4" (921)	36-1/4" (921)
Evaporator Water Connection size (NPS)	10" (254)	8" (203)	10" (254)	8" (203)	10" (254)	8" (203)	10" (254)	8" (203)
Condenser Inside Diameter	29-1/2" (749)	29-1/2" (749)	29-1/2" (749)	29-1/2" (749)	29-1/2" (749)	29-1/2" (749)	29-1/2" (749)	29-1/2" (749)
Condenser Nominal Connector size (NPS)	12" (304)	12" (304)	12" (304)	12" (304)	12" (304)	12" (304)	12" (304)	12" (304)
Weight- pound (kg) 150 Lb. Waterboxes								
Compressor weight	6440 (2921)	6440 (2921)	6440 (2921)	6440 (2921)	6440 (2921)	6440 (2921)	6440 (2921)	6440 (2921)
Evaporator weight	5949 (2698)	5949 (2698)	6283 (2850)	6283 (2850)	5940 (2694)	5940 (2694)	6480 (2939)	6480 (2939)
Condenser weight	4651 (2110)	4651 (2110)	5515 (2502)	5515 (2502)	4875 (2211)	4875 (2211)	5824 (2642)	5824 (2642)
Economizer weight	904 (410)	904 (410)	904 (410)	904 (410)	904 (410)	904 (410)	904 (410)	904 (410)
Starter panel weight	542 (246)	542 (246)	542 (246)	542 (246)	542 (246)	542 (246)	542 (246)	542 (246)
Control panel weight	70 (318)	70 (318)	70 (318)	70 (318)	70 (318)	70 (318)	70 (318)	70 (318)
I/C Piping and Supports	1216 (552)	1216 (552)	1216 (552)	1216 (552)	1216 (552)	1216 (552)	1216 (552)	1216 (552)
Waterboxes	1867 (847)	1891 (858)	1867 (847)	1891 (858)	1867 (847)	1891 (858)	1867 (847)	1891 (858)
Miscellaneous Item	298 (135)	298 (135)	298 (135)	298 (135)	298 (135)	298 (135)	298 (135)	298 (135)
Total Shipping Weight	22,024 (9990)	22,048 (10001)	23,222 (10553)	23,246 (10544)	22,239 (10541)	22,263 (10552)	23,728 (10763)	23,750 (10773)
Total Water Volume	2608 (1183)	2575 (1168)	2519 (1143)	2486 (1128)	2809 (1274)	2776 (1259)	2689 (1220)	2656 (1205)
Refrigerant and Oil	997 (452)	997 (452)	997 (452)	997 (452)	1047 (475)	1047 (475)	1047 (475)	1047 (475)
Total Weight	25,629 (11625)	25,620 (11621)	26,738 (12128)	26,729 (12124)	26,095 (11836)	26,086 (11832)	27,464 (12457)	27,453 (12452)

Table 4. General data: 700 ton family (continued)

Nominal Tonnage	560	560	560	560	630	630	630	630
Tube Outside Diameter (inch)	1.0	1.0	0.75	0.75	1.0	1.0	0.75	0.75
Evaporator Water Pass	Two	Three	Two	Three	Two	Three	Two	Three
Operational Data								
Minimum Evaporator Flow GPM (l/s)	625 (39.4)	417 (26.3)	566 (35.7)	378 (23.8)	706 (44.5)	471 (29.7)	628 (39.6)	419 (26.4)
Maximum Evaporator Flow GPM (l/s)	2293 (144.6)	1529 (96.4)	2077 (131)	1385 (87.4)	2581 (162.8)	1726 (108.9)	2304 (145.3)	1536 (96.9)
Minimum Condenser Flow GPM (l/s)	682 (43)	682 (43)	668 (42.1)	668 (42.1)	764 (48.2)	764 (48.2)	744 (47)	744 (47)
Maximum Condenser Flow GPM (l/s)	2501 (157.7)	2501 (157.7)	2450 (154.5)	2450 (154.5)	2801 (176.7)	2801 (176.7)	2727 (172)	2727 (172)
150 pound waterboxes								
Evaporator Water Storage gallons (l)	150.7 (570.4)	146.4 (554.2)	141.8 (537)	137.5 (520.5)	162.7 (616)	158.4 (600)	151 (572)	146.7 (555.3)
Condenser Water Storage gallons (l)	162.8 (616.3)	162.8 (616.3)	161 (609.5)	161 (609.5)	174.9 (662.1)	174.9 (662.1)	172.2 (652)	172.2 (652)
Evaporator 2-pass Weight								
Supply - pound (kg)	492.7 (223.5)	492.7 (223.5)	492.7 (223.5)	492.7 (223.5)	492.7 (223.5)	492.7 (223.5)	492.7 (223.5)	492.7 (223.5)
Return - pound (kg)	435.2 (197.4)	435.2 (197.4)	435.2 (197.4)	435.2 (197.4)	435.2 (197.4)	435.2 (197.4)	435.2 (197.4)	435.2 (197.4)
Evaporator 3-pass Weight								
Supply - pound (kg)	476.6 (216.2)	476.6 (216.2)	476.6 (216.2)	476.6 (216.2)	476.6 (216.2)	476.6 (216.2)	476.6 (216.2)	476.6 (216.2)
Return - pound (kg)	478.9 (217.2)	478.9 (217.2)	478.9 (217.2)	478.9 (217.2)	478.9 (217.2)	478.9 (217.2)	478.9 (217.2)	478.9 (217.2)
Condenser 2-pass Weight								
Supply - pound (kg)	500.2 (226.9)	500.2 (226.9)	500.2 (226.9)	500.2 (226.9)	500.2 (226.9)	500.2 (226.9)	500.2 (226.9)	500.2 (226.9)
Return - pound (kg)	437.6 (198.5)	437.6 (198.5)	437.6 (198.5)	437.6 (198.5)	437.6 (198.5)	437.6 (198.5)	437.6 (198.5)	437.6 (198.5)
300 pound Waterboxes								
Evaporator Water Storage gallons (l)	151 (571.6)	146.6 (554.9)	142.1 (537.9)	137.7 (521.3)	163 (617)	158.6 (600.4)	151.3 (572.7)	146.9 (556.1)
Condenser Water Storage gallons (l)	163.4 (618.5)	163.4 (618.5)	161.6 (611.7)	161.6 (611.7)	175.5 (664.3)	175.5 (664.3)	172.8 (654.1)	172.8 (654.1)
Evaporator 2-pass Weight								
Supply - pound (kg)	625.9 (283.9)	625.9 (283.9)	625.9 (283.9)	625.9 (283.9)	625.9 (283.9)	625.9 (283.9)	625.9 (283.9)	625.9 (283.9)
Return - pound (kg)	590.5 (267.8)	590.5 (267.8)	590.5 (267.8)	590.5 (267.8)	590.5 (267.8)	590.5 (267.8)	590.5 (267.8)	590.5 (267.8)
Evaporator 3-pass Weight								
Supply - pound (kg)	624.9 (283.4)	624.9 (283.4)	624.9 (283.4)	624.9 (283.4)	624.9 (283.4)	624.9 (283.4)	624.9 (283.4)	624.9 (283.4)
Return - pound (kg)	627.2 (284.5)	627.2 (284.5)	627.2 (284.5)	627.2 (284.5)	627.2 (284.5)	627.2 (284.5)	627.2 (284.5)	627.2 (284.5)
Condenser 2-pass Weight								
Supply - pound (kg)	625.1 (283.5)	625.1 (283.5)	625.1 (283.5)	625.1 (283.5)	625.1 (283.5)	625.1 (283.5)	625.1 (283.5)	625.1 (283.5)
Return - pound (kg)	594.4 (269.6)	594.4 (269.6)	594.4 (269.6)	594.4 (269.6)	594.4 (269.6)	594.4 (269.6)	594.4 (269.6)	594.4 (269.6)



General Information

Table 4. General data: 700 ton family (continued)

Nominal Tonnage	700			
Tube Outside Diameter (inch)	1.0		0.75	
Evaporator Water Pass	Two	Three	Two	Three
Refrigerant Charge - pounds (kg)	975 (442)	975 (442)	975 (442)	975 (442)
Oil charge - gallons (l)	15 (56.8)	15 (56.8)	15 (56.8)	15 (56.8)
Overall Dimensions - Feet-Inch (mm)				
Length	16'11" (5153)	16'11" (5153)	16'11" (5153)	16'11" (5153)
Width	6'10" (2075)	6'10" (2075)	6'10" (2075)	6'10" (2075)
Height	7'5" (2269)	7'5" (2269)	7'5" (2269)	7'5" (2269)
Evaporator Inside Diameter	36-1/4" (921)	36-1/4" (921)	36-1/4" (921)	36-1/4" (921)
Evaporator Water Connection size (NPS)	10" (254)	8" (203)	10" (254)	8" (203)
Condenser Inside Diameter	29-1/2" (749)	29-1/2" (749)	29-1/2" (749)	29-1/2" (749)
Condenser Nominal Connector size (NPS)	12" (304)	12" (304)	12" (304)	12" (304)
Weight- pound (kg) 150 Lb. Waterboxes				
Compressor weight	6440 (2921)	6440 (2921)	6440 (2921)	6440 (2921)
Evaporator weight	6320 (2867)	6320 (2867)	6701 (3040)	6701 (3040)
Condenser weight	5077 (2303)	5077 (2303)	6122 (2777)	6122 (2777)
Economizer weight	904 (410)	904 (410)	904 (410)	904 (410)
Starter panel weight	542 (246)	542 (246)	542 (246)	542 (246)
Control panel weight	70 (318)	70 (318)	70 (318)	70 (318)
I/C Piping and Supports	1216 (552)	1216 (552)	1216 (552)	1216 (552)
Waterboxes	1867 (847)	1891 (858)	1867 (847)	1891 (858)
Miscellaneous Item	298 (135)	298 (135)	298 (135)	298 (135)
Total Shipping Weight	22,821 (10351)	22,845 (10362)	24,247 (10998)	24,271 (11009)
Total Water Volume	2999 (1360)	2966 (1345)	2866 (1300)	2833 (1285)
Refrigerant and Oil	1097 (498)	1097 (498)	1097 (498)	1097 (498)
Total Weight	26,917 (12209)	26,908 (12205)	28,210 (12796)	28,201 (12792)

Table 4. General data: 700 ton family (continued)

Nominal Tonnage	700			
Tube Outside Diameter (inch)	1.0		0.75	
Evaporator Water Pass	Two	Three	Two	Three
Operational Data				
Minimum Evaporator Flow GPM (l/s)	784 (49.5)	523 (33)	698 (44)	465 (29.3)
Maximum Evaporator Flow GPM (l/s)	2874 (181.3)	1916 (120.9)	2559 (161.4)	1706 (107.6)
Minimum Condenser Flow GPM (l/s)	838 (52.9)	838 (52.9)	816 (51.5)	816 (51.5)
Maximum Condenser Flow GPM (l/s)	3071 (193.7)	3071 (193.7)	2993 (188.8)	2993 (188.8)
150 pound waterboxes				
Evaporator Water Storage gallons (l)	174.4 (660.2)	170.1 (644)	161.5 (611.3)	157.2 (595.1)
Condenser Water Storage gallons (l)	185.8 (703.3)	185.8 (703.3)	183 (693)	183 (693)
Evaporator 2-pass Weight				
Supply - pound (kg)	492.7 (223.5)	492.7 (223.5)	492.7 (223.5)	492.7 (223.5)
Return - pound (kg)	435.2 (197.4)	435.2 (197.4)	435.2 (197.4)	435.2 (197.4)
Evaporator 3-pass Weight				
Supply - pound (kg)	476.6 (216.2)	476.6 (216.2)	476.6 (216.2)	476.6 (216.2)
Return - pound (kg)	478.9 (217.2)	478.9 (217.2)	478.9 (217.2)	478.9 (217.2)
Condenser 2-pass Weight				
Supply - pound (kg)	500.2 (226.9)	500.2 (226.9)	500.2 (226.9)	500.2 (226.9)
Return - pound (kg)	437.6 (198.5)	437.6 (198.5)	437.6 (198.5)	437.6 (198.5)
300 pound Waterboxes				
Evaporator Water Storage gallons (l)	174.7 (661.3)	170.3 (644.7)	161.8 (612.5)	157.4 (595.8)
Condenser Water Storage gallons (l)	186.4 (705.6)	186.4 (705.6)	183.6 (695)	183.6 (695)
Evaporator 2-pass Weight				
Supply - pound (kg)	625.9 (283.9)	625.9 (283.9)	625.9 (283.9)	625.9 (283.9)
Return - pound (kg)	590.5 (267.8)	590.5 (267.8)	590.5 (267.8)	590.5 (267.8)
Evaporator 3-pass Weight				
Supply - pound (kg)	624.9 (283.4)	624.9 (283.4)	624.9 (283.4)	624.9 (283.4)
Return - pound (kg)	627.2 (284.5)	627.2 (284.5)	627.2 (284.5)	627.2 (284.5)
Condenser 2-pass Weight				
Supply - pound (kg)	625.1 (283.5)	625.1 (283.5)	625.1 (283.5)	625.1 (283.5)
Return - pound (kg)	594.4 (269.6)	594.4 (269.6)	594.4 (269.6)	594.4 (269.6)



General Information

Table 5. General data: 800 ton units

Nominal Tonnage	800			
Tube Outside Diameter (Inch)	1.0		0.75	
Evaporator Water Pass	Two	Three	Two	Three
Refrigerant Type	R134a	R134a	R134a	R134a
Refrigerant Charge-pounds (kg)	975 (442.3)	975 (442.3)	975 (442.3)	975 (442.3)
Oil Charge gallon (l)	15 (56.8)	15 (56.8)	15 (56.8)	15 (56.8)
Overall Dimensions - Feet-Inch (mm)				
Length	16' 4877	16' 4877	16' 4877	16' 4877
Width	6' - 9 3/4" (2076)	6' - 9 3/4" (2076)	6' - 9 3/4" (2076)	6' - 9 3/4" (2076)
Height	7' - 5 11/32" (2270)	7' - 5 11/32" (2270)	7' - 5 11/32" (2270)	7' - 5 11/32" (2270)
Evaporator Inside Diameter	3' - 1/4" (9208)	3' - 1/4" (9208)	3' - 1/4" (9208)	3' - 1/4" (9208)
Evaporator Water Connection (NPS)	10" (250)	8" (203)	10" (250)	8" (203)
Condenser Inside Diameter	2' - 5 1/2" (749)	2' - 5 1/2" (749)	2' - 5 1/2" (749)	2' - 5 1/2" (749)
Condenser Nominal Connector Size (NPS)	12" (305)	12" (305)	12" (305)	12" (305)
Weight - pounds (kg) except Waterboxes				
Compressor/Motor	6800 (3084)	6800 (3084)	6800 (3084)	6800 (3084)
Evaporator	5835 (2647)	6275 (2846)	5835 (2647)	6275 (2846)
Condenser	4375 (1985)	5400 (2449)	4375 (1985)	5400 (2449)
Economizer	799 (362)	799 (362)	799 (362)	799 (362)
Starter Panel	542 (246)	542 (246)	542 (246)	542 (246)
Control Panel	70 (318)	70 (318)	70 (318)	70 (318)
Miscellaneous Item	2745 (1245)	2745 (1245)	2745 (1245)	2745 (1245)
Shipping Weight	25218 (11439)	25218 (11439)	25218 (11439)	25218 (11439)
Operating Weight	29924 (13573)	29924 (13573)	29924 (13573)	29924 (13573)
Operational Data				
Minimum Evaporator Flow in gpm (l/sec)	784 (50)	523 (33)	698 (44)	465 (29)
Maximum Evaporator Flow in gpm (l/sec)	3071 (194)	1916 (121)	1873 (118)	1248 (79)
Minimum Condenser Flow in gpm (l/sec)	838 (53)	838 (53)	816 (52)	816 (52)
Maximum Condenser Flow in gpm (l/sec)	3071 (194)	3071 (194)	2993 (189)	2993 (189)

Table 5. General data: 800 ton units (continued)

Nominal Tonnage		800			
Tube Outside Diameter (inch)		1.0		0.75	
Evaporator Water Pass	Two	Three	Two	Three	
Water Volume - 150 pound Waterboxes					
Evaporator Water Storage gallon (l)	190.4 (721)	185.4 (702)	177.4 (672)	172.4 (653)	
Condenser Water Storage gallon (l)	213.5 (808)	213.5 (808)	218.0 (828)	218.0 (828)	
Evaporator 2-pass Weight Supply - pound (kg)	303.57 (137.7)	303.57 (137.7)	303.57 (137.7)	303.57 (137.7)	
Return - pound (kg)	337.16 (152.9)	337.16 (152.9)	337.16 (152.9)	337.16 (152.9)	
Evaporator 3-pass Weight Supply - pound (kg)	313.56 (142.2)	313.56 (142.2)	313.56 (142.2)	313.56 (142.2)	
Return - pound (kg)	331.72 (150.5)	331.72 (150.5)	331.72 (150.5)	331.72 (150.5)	
Condenser 2-pass Weight Supply - pound (kg)	303.69 (137.8)	303.69 (137.8)	303.69 (137.8)	303.69 (137.8)	
Return - pound (kg)	340.67 (154.5)	340.67 (154.5)	340.67 (154.5)	340.67 (154.5)	
300 pound Waterboxes					
Evaporator Water Storage gallon (l)	190.4 (721)	185.4 (702)	177.4 (672)	172.4 (653)	
Condenser Water Storage gallon (l)	214.5 (812)	214.5 (812)	219.0 (829)	219.0 (829)	
Evaporator 2-pass Weight Supply - pound (kg)	426.69 (193.5)	426.69 (193.5)	426.69 (193.5)	426.69 (193.5)	
Return - pound (kg)	446.20 (202.4)	446.20 (202.4)	446.20 (202.4)	446.20 (202.4)	
Evaporator 3-pass Weight Supply - pound (kg)	447.81 (203.1)	447.81 (203.1)	447.81 (203.1)	447.81 (203.1)	
Return - pound (kg)	447.98 (203.2)	447.98 (203.2)	447.98 (203.2)	447.98 (203.2)	
Condenser 2-pass Weight Supply - pound (kg)	421.43 (191.2)	421.43 (191.2)	421.43 (191.2)	421.43 (191.2)	
Return - pound (kg)	436.11 (197.8)	436.11 (197.8)	436.11 (197.8)	436.11 (197.8)	



General Information

Table 6. General data: 1000 ton family

Bundle	A	A	A	A	B	B	B	B
Tube Outside Diameter (inch)	1.0	1.0	0.75	0.75	1.0	1.0	0.75	0.75
Evaporator Water pass	Two	Three	Two	Three	Two	Three	Two	Three
Overall Dimensions - Feet-Inch (mm)								
Length	17' - 5 13/32" (5320)	17' - 5 13/32" (5320)	17' - 5 13/32" (5320)	17' - 5 13/32" (5320)	17' - 5 13/32" (5320)	17' - 5 13/32" (5320)	17' - 5 13/32" (5320)	17' - 5 13/32" (5320)
Width	7' - 6 39/64" (2301)	7' - 6 39/64" (2301)	7' - 6 39/64" (2301)	7' - 6 39/64" (2301)	7' - 6 39/64" (2301)	7' - 6 39/64" (2301)	7' - 6 39/64" (2301)	7' - 6 39/64" (2301)
Height	8' - 4" (2540)	8' - 4" (2540)	8' - 4" (2540)	8' - 4" (2540)	8' - 4" (2540)	8' - 4" (2540)	8' - 4" (2540)	8' - 4" (2540)
Evaporator Inside Diameter	3' 7 3/4" (1111)	3' 7 3/4" (1111)	3' 7 3/4" (1111)	3' 7 3/4" (1111)	3' 7 3/4" (1111)	3' 7 3/4" (1111)	3' 7 3/4" (1111)	3' 7 3/4" (1111)
Evaporator Water Connection size (NPS)	12" (305)	10" (250)	12" (305)	10" (250)	12" (305)	10" (250)	12" (305)	10" (250)
Condenser Inside Diameter	2' - 11 1/4" (895)	2' - 11 1/4" (895)	2' - 11 1/4" (895)	2' - 11 1/4" (895)	2' - 11 1/4" (895)	2' - 11 1/4" (895)	2' - 11 1/4" (895)	2' - 11 1/4" (895)
Condenser Nominal Connector size (NPS)	14" (356)	14" (356)	14" (356)	14" (356)	14" (356)	14" (356)	14" (356)	14" (356)
Weight - pounds (kg) 150 pound Waterboxes								
Compressor weight	9493 (4306)	9493 (4306)	9493 (4306)	9493 (4306)	9493 (4306)	9493 (4306)	9493 (4306)	9493 (4306)
Evaporator weight	7537 (3419)	7537 (3419)	8190 (3715)	8190 (3715)	7787 (3532)	7787 (3532)	8474 (3844)	8474 (3844)
Condenser weight	6571 (2981)	6571 (2981)	7707 (3496)	7707 (3496)	6816 (3092)	6816 (3092)	8148 (3696)	8148 (3696)
Economizer weight	1461 (663)	1461 (663)	1461 (663)	1461 (663)	1461 (663)	1461 (663)	1461 (663)	1461 (663)

General Information

Table 6. General data: 1000 ton family (continued)

Bundle	C	C	C	C	D	D	D	D
Tube Outside Diameter (inch)	1.0	1.0	0.75	0.75	1.0	1.0	0.75	0.75
Evaporator Water pass	Two	Three	Two	Three	Two	Three	Two	Three
Overall Dimensions - Feet-Inch (mm)								
Length	17' - 5 13/32" (5320)	17' - 5 13/32" (5320)	17' - 5 13/32" (5320)	17' - 5 13/32" (5320)	17' - 5 13/32" (5320)	17' - 5 13/32" (5320)	17' - 5 13/32" (5320)	17' - 5 13/32" (5320)
Width	7' - 6 39/64" (2301)	7' - 6 39/64" (2301)	7' - 6 39/64" (2301)	7' - 6 39/64" (2301)	7' - 6 39/64" (2301)	7' - 6 39/64" (2301)	7' - 6 39/64" (2301)	7' - 6 39/64" (2301)
Height	8' - 4" (2540)	8' - 4" (2540)	8' - 4" (2540)	8' - 4" (2540)	8' - 4" (2540)	8' - 4" (2540)	8' - 4" (2540)	8' - 4" (2540)
Evaporator Inside Diameter	3' 7 3/4" (1111)	3' 7 3/4" (1111)	3' 7 3/4" (1111)	3' 7 3/4" (1111)	3' 7 3/4" (1111)	3' 7 3/4" (1111)	3' 7 3/4" (1111)	3' 7 3/4" (1111)
Evaporator Water Connection size (NPS)	12" (305)	10" (250)	12" (305)	10" (250)	12" (305)	10" (250)	12" (305)	10" (250)
Condenser Inside Diameter	2' - 11 1/4" (895)	2' - 11 1/4" (895)	2' - 11 1/4" (895)	2' - 11 1/4" (895)	2' - 11 1/4" (895)	2' - 11 1/4" (895)	2' - 11 1/4" (895)	2' - 11 1/4" (895)
Condenser Nominal Connector size (NPS)	14" (356)	14" (356)	14" (356)	14" (356)	14" (356)	14" (356)	14" (356)	14" (356)
Weight - pounds (kg) 150 pound Waterboxes								
Compressor weight	9493 (4306)	9493 (4306)	9493 (4306)	9493 (4306)	9493 (4306)	9493 (4306)	9493 (4306)	9493 (4306)
Evaporator weight	7537 (3419)	7537 (3419)	8190 (3715)	8190 (3715)	7787 (3532)	7787 (3532)	8474 (3844)	8474 (3844)
Condenser weight	6571 (2981)	6571 (2981)	7707 (3496)	7707 (3496)	6816 (3092)	6816 (3092)	8148 (3696)	8148 (3696)
Economizer weight	1461 (663)	1461 (663)	1461 (663)	1461 (663)	1461 (663)	1461 (663)	1461 (663)	1461 (663)

Cooling Cycle

The refrigeration cycle of the CVGF chiller can be described using the pressure-enthalpy diagram shown in Figure 4. Key state points are indicated and will be referred to in the following discussion. A schematic of the system showing refrigerant flow is given in Figure 5.

Evaporator -

A liquid vapor refrigerant mixture enters the evaporator at state point 1. Liquid refrigerant is vaporized to state point 2 as it absorbs heat from the system cooling load. The vaporized refrigerant flows into the compressor first stage.

Compressor first stage -

Refrigerant vapor is drawn from the evaporator into the first stage compressor. The first stage impeller accelerates the vapor increasing its temperature and pressure to state point 3.

Figure 4. P-H chart

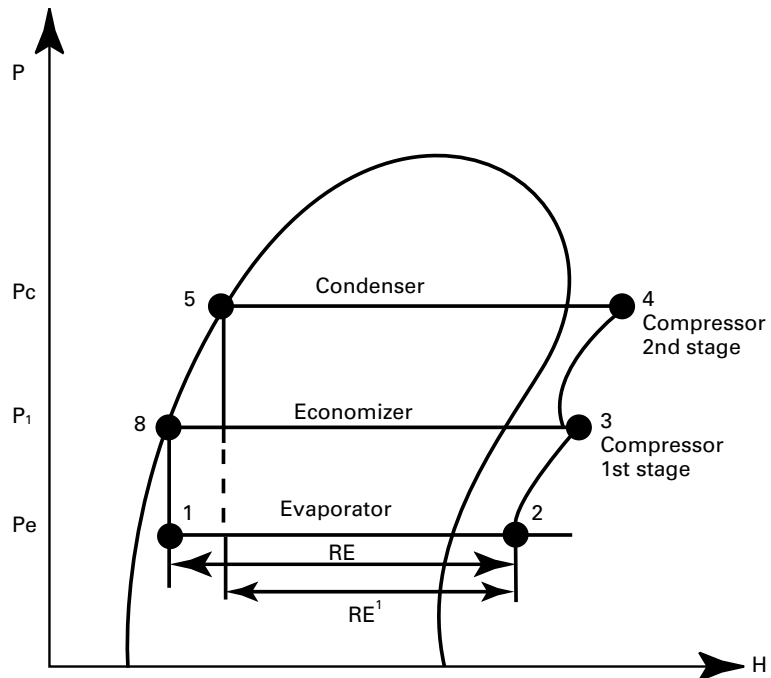

Compressor second stage -

Refrigerant vapor leaving the first stage compressor is mixed with cooler refrigerant vapor from the economizer. This mixing lowers the enthalpy of the vapor entering the second stage. The second stage impeller accelerates the vapor, further increasing its temperature and pressure to state point 4.

Condenser - Refrigerant vapor enters the condenser where the system cooling load and heat of compression are rejected to the condenser water circuit. This heat rejection cools and condenses the refrigerant vapor to a liquid at state point 5.

Economizer and refrigerant orifice system -

Liquid refrigerant leaving the condenser at state point 5 flows through the first orifice and enters the economizer to flash a small amount of refrigerant at an intermediate pressure labeled P1. Flashing some liquid refrigerant cools the remaining liquid to state point 8.

Another benefit of flashing refrigerant is to increase the total evaporator Refrigeration Effect from RE' to RE. The economizer provides around 4 percent energy savings compared to chillers with no economizer.

To complete the operating cycle, liquid refrigerant leaving the economizer at state point 8 flows through a second orifice.

Here refrigerant pressure and temperature are reduced to evaporator conditions at state point 1.

An innovative design feature of the CVGF chiller is maximizing the evaporator heat transfer performance while minimizing refrigerant charge requirements. This is accomplished by the Trane-patented falling film evaporator design. The amount of refrigerant charge required in CVGF is less than that in comparably sized chillers of flooded evaporator design.

General Information

Figure 5. Refrigerant flow diagram

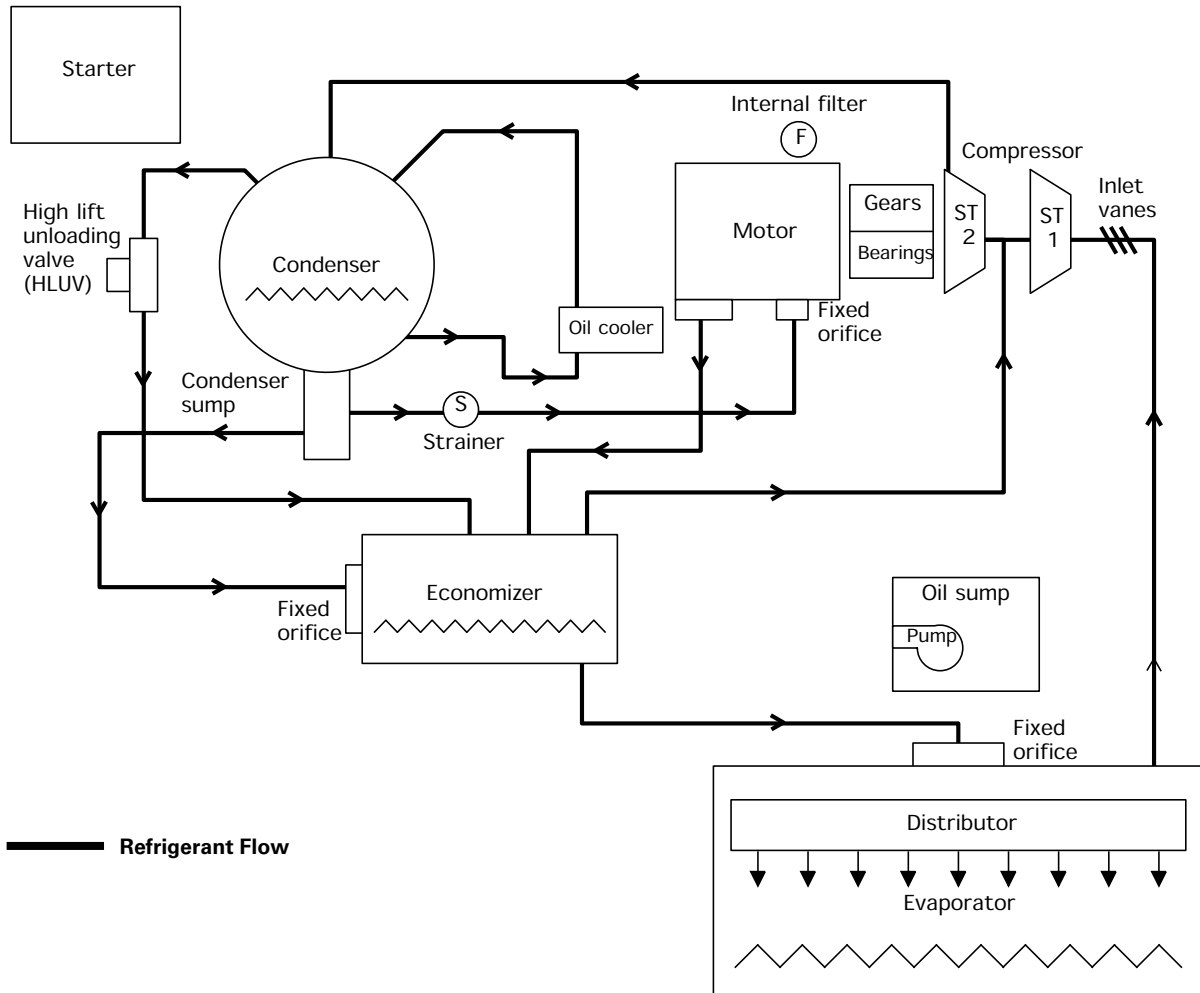

Compressor Description

The CVGF compressor consists of three distinct sections: the two-stage centrifugal compressor, the motor, and the gear box with integral oil sump. See Figure 6.

Compressor

The centrifugal compressor is two-stage with high-strength aluminum alloy fully shrouded impellers. The impellers are tested at 25 percent over design operating speed. The rotating assembly is dynamically balanced for vibration of less than 5.1 mm/sec (0.2 ips peak velocities) at nominal operating speeds. The control system affords 20 to 100 percent capacity modulation by electrically actuated guide vanes upstream of each impeller.

General Information

Figure 6. Compressor cross-section view

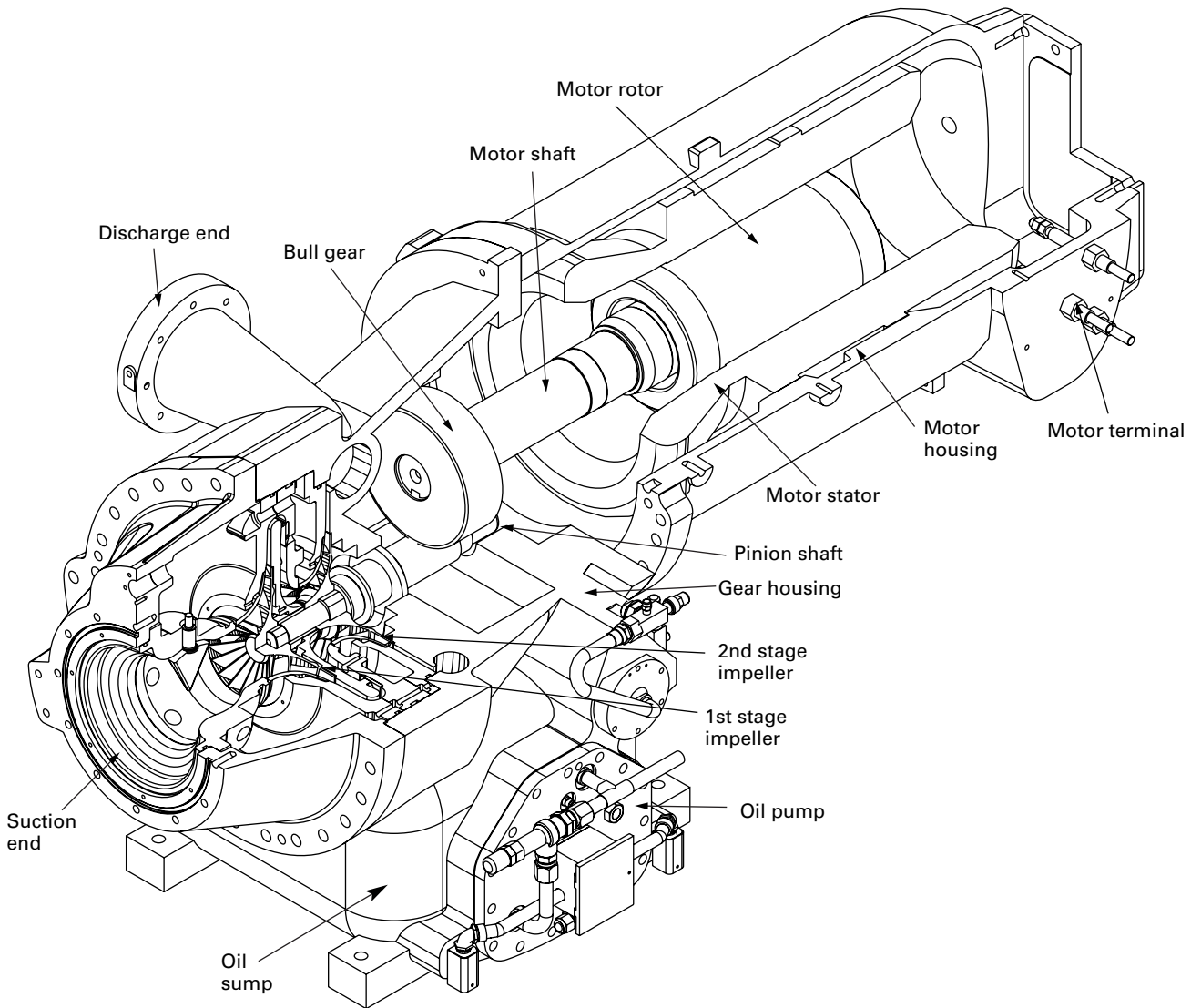

Drive Train

The drive train consists of helical bull and pinion gears. Gear tooth surfaces are case hardened and precision ground. The one-piece impeller shaft is supported by hydrodynamic thrust and radial bearings.

Motor

The motor is a hermetic, liquid refrigerant cooled, two-pole, low-slip squirrel cage induction motor. A radial hydrodynamic bearing and duplex angular contact ball bearings support the rotor assembly. Winding-embedded sensors provide positive thermal protection.

Controls Overview

Controls Operator Interface

Information is tailored to operators, service technicians and owners. When operating a chiller, there is specific information you need on a day-to-day basis such as setpoints, limits, diagnostic information, and reports.

When servicing a chiller, you need different information and a lot more of it such as historic and active diagnostics, configuration settings, and customizable control algorithms, as well as operation settings.

By providing two different tools, one for daily operation and one for periodic service, appropriate information is readily accessible.

Large display™ Human Interface

For the operator, day-to-day operational information is presented at the panel. data (English or SI units) are simultaneously displayed on the touch-sensitive screen. Logically organized groups of information such as chiller modes of operation, active diagnostics, settings and reports put information conveniently at your fingertips. See Operator Interface Section for details.

UT™ Chiller

For the service technician or advanced operator all chiller status, machine configuration settings, customizable limits, and up to 60 active or historic diagnostics are displayed through the UT™ interface. Using UT™, a technician can interact with an individual device or a group of devices for advanced troubleshooting. LED lights and their respective UT™ indicators visually confirm the viability of each device. Any PC that meets the system requirements may download the service interface software and Tracer AdaptiView updates. For more information on UT™ visit your local Trane Service company, or The Trane Company's website at www.trane.com.

General Information

Figure 7. CVGF sequence of operation overview

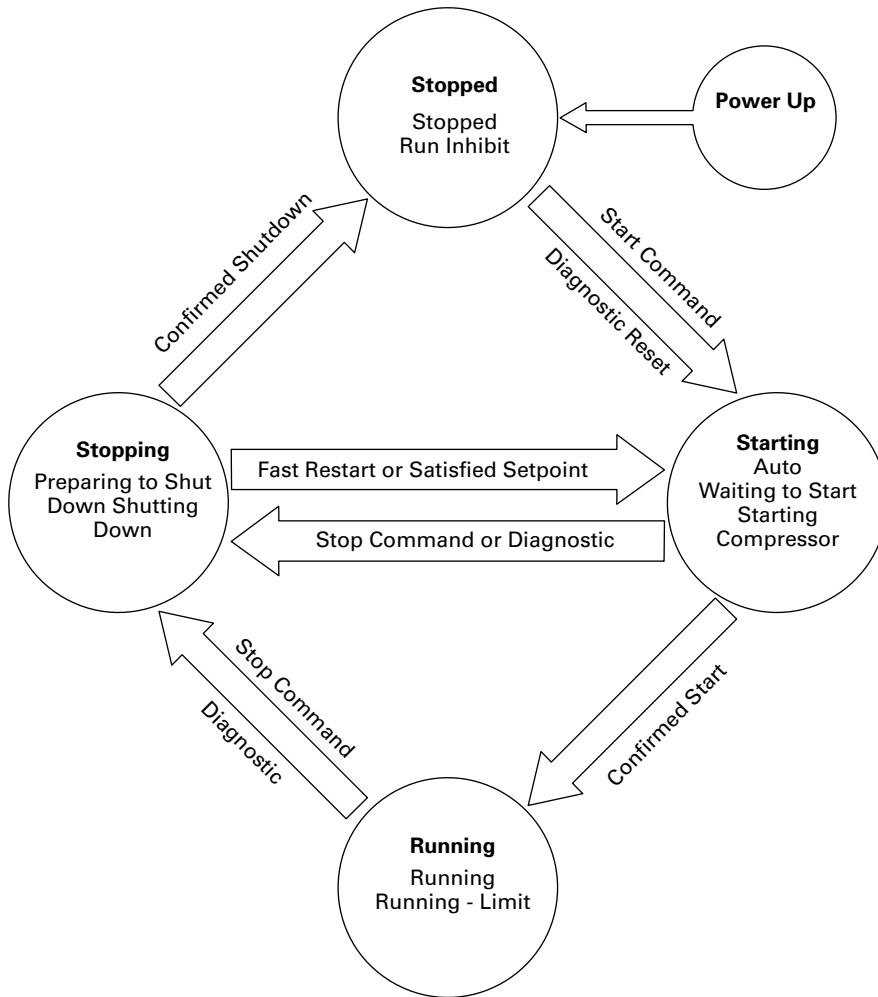
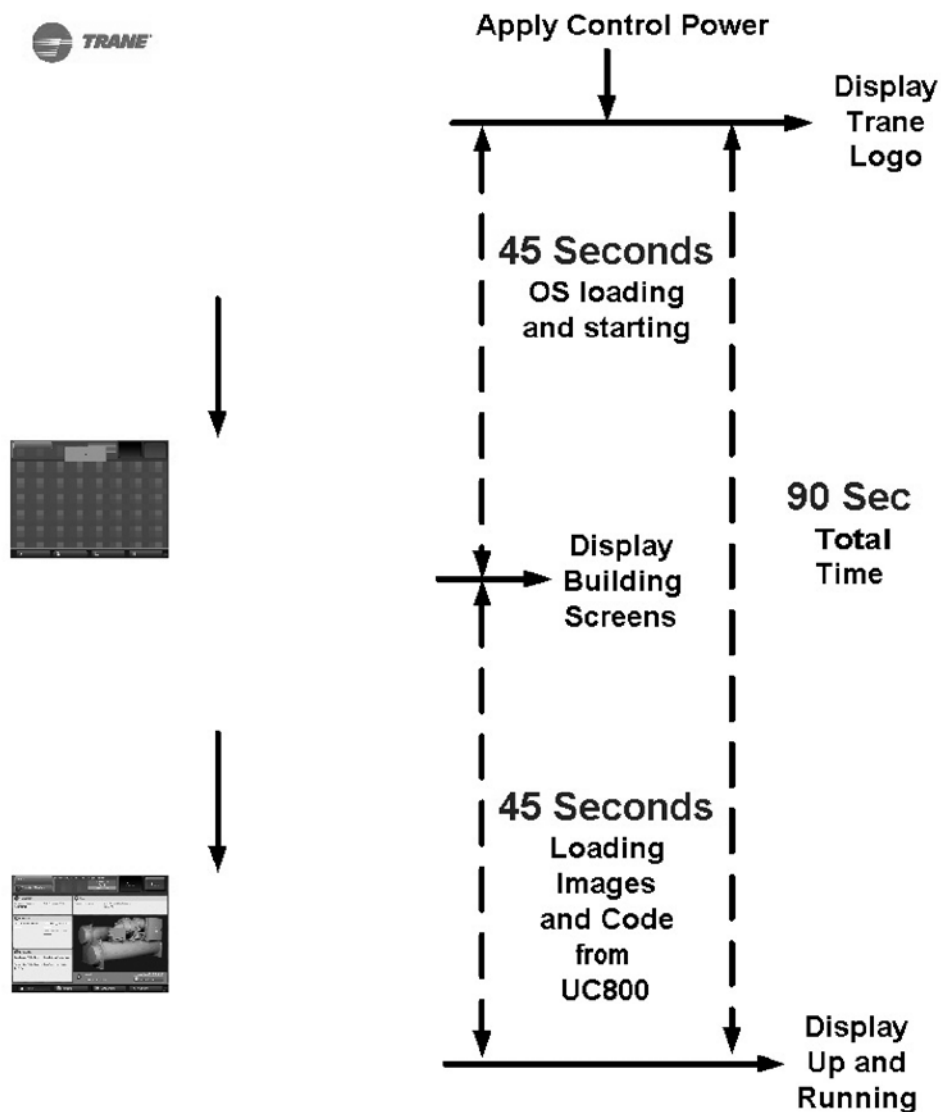

Figure 8. Sequence of operation: power up

AdaptiView Display Power Up Boot Sequence:



*Note: The variation in AdaptiView Power Up time is dependent on the number of installed options.

General Information

Figure 9. Sequence of operation: running

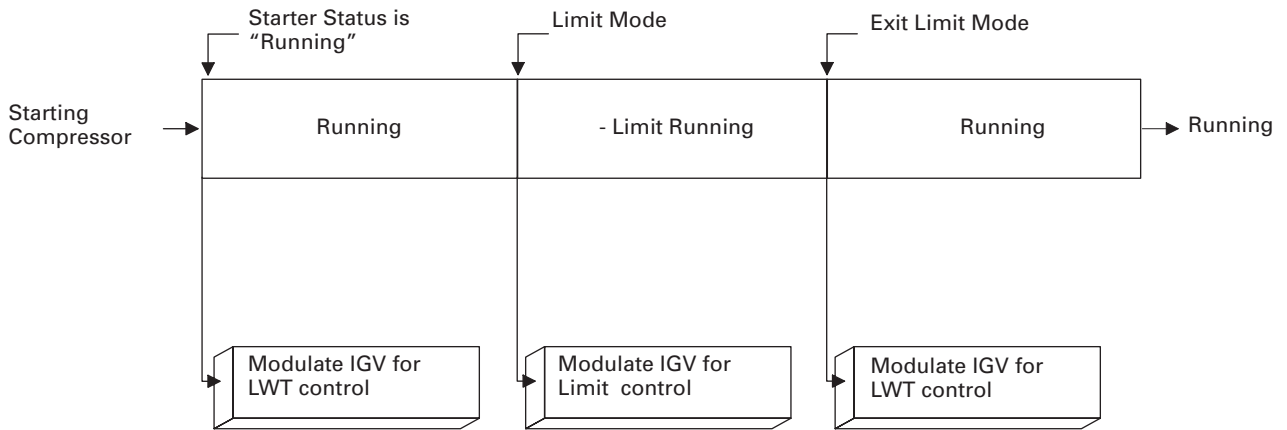
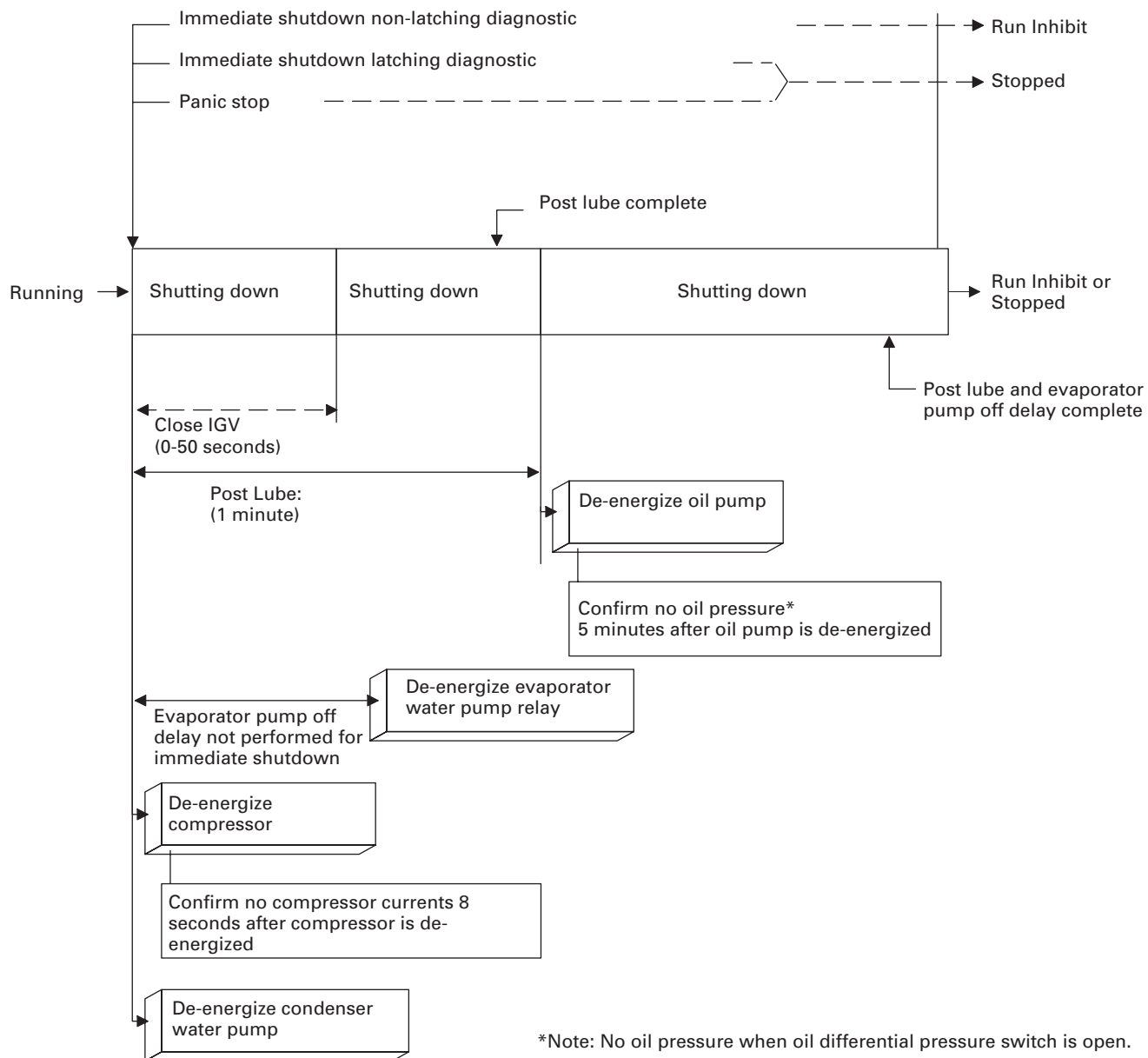
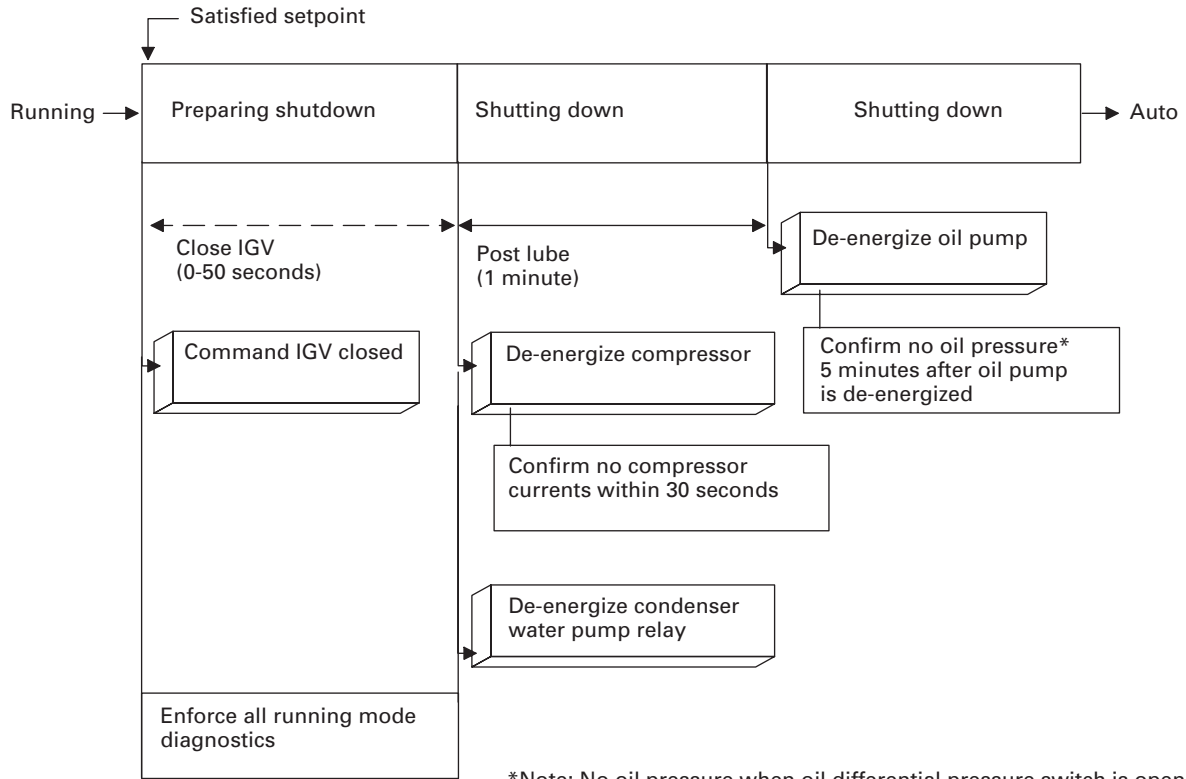

Figure 10. Immediate shutdown to stopped or run inhibit



General Information

Figure 11. CVGF sequence of operation: satisfaction setpoint



Oil Management

The primary purpose of Oil Management is to ensure appropriate and sufficient lubrication to the bearings

during compressor operation and to minimize refrigerant dilution in the oil.

The Oil Management system performs safety checks and manages the operation of the Oil Pump and the Oil Heater. The sensor inputs used for these purposes are the Differential Oil Switch, and the Oil Temperature.

Two oil heater outputs exist, that should always operate simultaneously, for example, both on or both off.

Note: The Oil Pump and the Oil Heater are never energized at the same time.

Low Oil Temperature Start Inhibit Setpoint default is: 95° F

When enhanced oil protection is enabled, the low oil temperature start inhibit is the saturated evaporator at 30°F (16.6°C) or 105°F (40.5°C), whichever is higher.

When enhanced oil temperature protection is enabled, the oil temperature setpoint is fixed at 136°F (57.8°C).

The oil temperature control setpoint range is settable from: 100 to 160°F (37.8 to 71.1°C)

Essential Modes

The Oil-Management has the following modes:

1. Low Temperature Start Inhibit: The oil temperature is at or below the low oil temperature start inhibit setpoint. The heater is energized to raise the oil temperature. See Low Temperature Start Inhibit section for information about Enhanced Oil Temp Protection. This mode is indicated to the user.
2. Idle: The oil pump is off. The oil temperature is maintained by the heater, at the control temperature setpoint +/- 2.5°F (1.4°C).
3. Pre-lube: The oil pump lubricates the bearing for 30 seconds before the compressor starts. This mode is indicated to the user.
4. Running: The oil pump continues to lubricate the bearings when the compressor is running.
5. Post-lube: The oil pump lubricates the bearings for 60 seconds after the compressor is stopped to ensure bearings remain lubricated as the compressor coasts to a stop. If a start command is issued while in post-lube, a quick restart will be performed. The post-lube mode is indicated to the user on Large display™ and UT™.
6. Manual: The oil pump can be commanded on and off in a manual mode.

Oil Temperature Control

The oil heater is used to maintain the oil temperature within +/- 2.5°F (4.5°C) of the oil temperature control setpoint. The oil heater is commanded off when the oil pump is commanded on.

Oil Differential Pressure Check

The Oil Differential Pressure Check validates the oil differential pressure before the oil pump is turned on. This check is necessary in case the differential pressure switch is not operational. Without this check, the differential oil pressure feedback is gone. This check is made after post-lube is complete to verify that the differential pressure has dropped to indicate no oil flow.

Here are the details:

- AdaptiView verifies that the pressure switch is reading no differential pressure with the oil pump off before proceeding with pre-lube.

General Information

- AdaptiView displays a mode Waiting for Low Oil Differential Press.
- The check is made if oil pump is off and before it is turned on.
- AdaptiView allows five minutes for the differential oil pressure switch to open.
- This check is performed on power up or reset also. If a MPL occurred or power up was within the post-lube time, oil pump is running so do not do the check. Protective Diagnostics and their description

Differential Oil Pressure Overdue

is a latching diagnostic that can come up while the unit is in prelube. The differential pressure switch status is used instead of the Low Differential Oil Pressure Cutout setpoint.

Low Differential Pressure Cutout

is a latching diagnostic that can come up while the unit is running. Oil pressure is indicative of oil flow and active oil pump operation. Significant fall in oil pressure is indicative of failure of the oil pump, oil leakage, or other blockage in the oil circuit. Once oil flow has been established, if the differential pressure switch indicates there is not oil pressure for 2 seconds, this diagnostic will be issued.

Unexpected Differential Oil

Pressure is a latching diagnostic that can come up while the unit is idle and is implemented to recognize and ensure that the pressure switch is operational and that it is open for a period of five minutes.

Figure 12. Oil circuit diagram

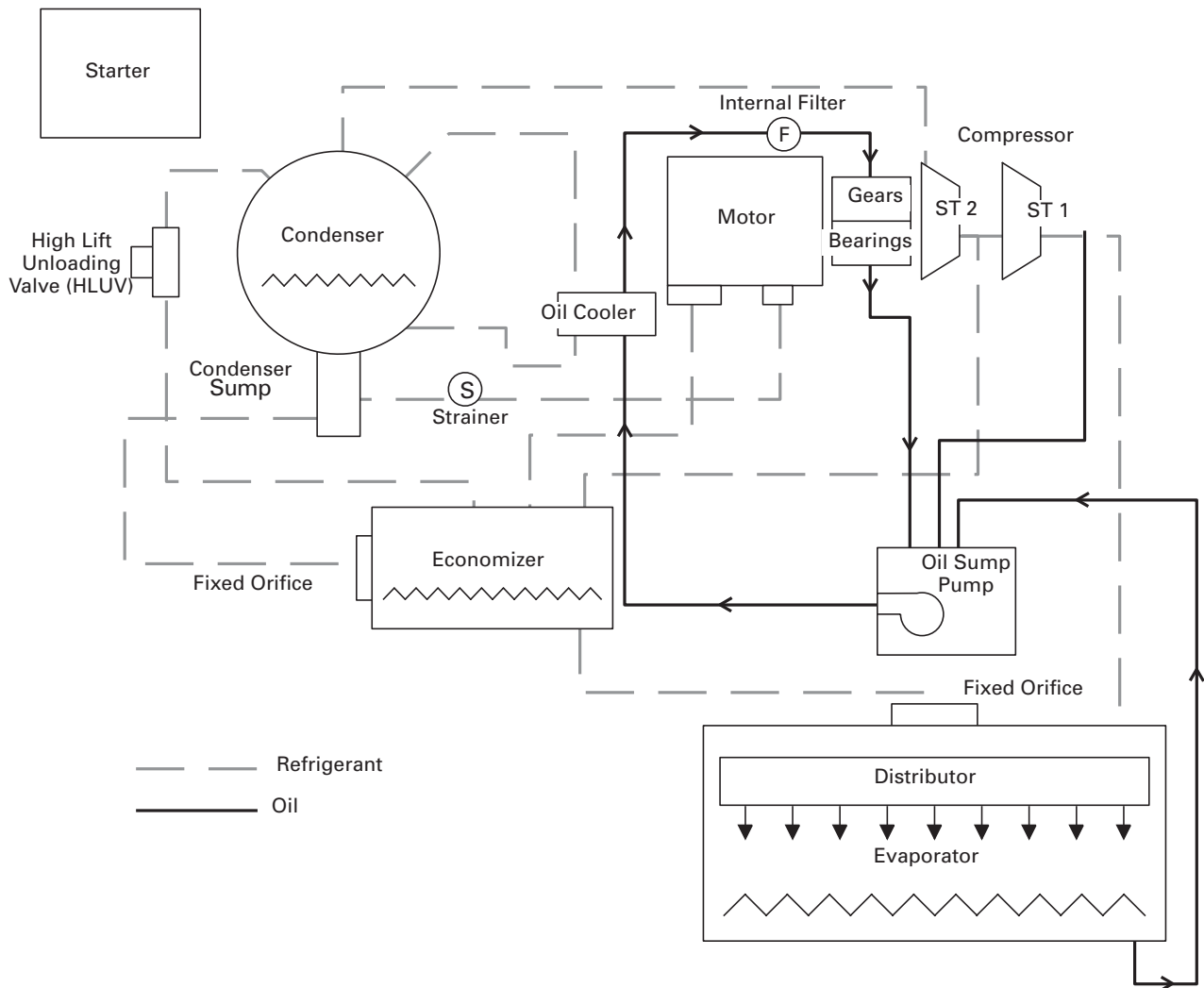



Installation: Mechanical

Storage

If the chiller is to be stored for at least one month prior to installation, observe the following precautions:

- Do not remove the protective coverings from the electrical panel.
- Store the chiller in a dry, vibration-free, secure area.
- At least every three months, attach a gauge to the service valve and manually check the pressure of dry nitrogen in the refrigerant circuit. If the pressure is below 5 psig (34 kPa) at 70°F (20°C), call a qualified service organization and the appropriate Trane sales office.

Location Requirements Noise Considerations

- Locate the unit away from sound-sensitive areas.
- Install the isolation pads or isolation springs under the unit.
- Use rubber boot-type isolators for all water piping at the unit.
- Use flexible electrical conduit for final connection to the UPC.

Note: Consult an acoustical engineer for critical applications.

Foundation

Provide rigid, non-warping mounting pads or a concrete foundation of sufficient strength and mass to support the chiller operating weight (including completed piping and full operating charges of refrigerant, oil and water).

After the chiller is in place, level the chiller within 1/4" (6 mm) over its length and width. Trane is not responsible for equipment problems resulting from an improperly designed or constructed foundation.

Vibration Eliminators

- Use rubber boot-type isolators for all water piping at the unit.
- Use flexible electrical conduit for final connection to the UPC.
- Isolate all pipe hangers and be sure they are not supported by main structural beams that could introduce vibration into occupied spaces.
- Make sure that the piping does not put additional stress on the unit.

Note: Do not use metal braidedtype eliminators on the water piping. Metal braided eliminators are not effective at the frequencies at which the unit

Clearances

Provide enough space around the unit to allow the installation and maintenance personnel unrestricted access to all service points. Refer to submittal drawings for the unit dimensions.

Allow adequate clearance for condenser and compressor servicing. A minimum of 36" (914 mm) is recommended for compressor service and to provide sufficient clearance for the opening of control panel doors. Refer to Figures 13 and 14, Tables 7 and 8 for minimum clearances required for condenser tube service. In all cases, local codes will take precedence over these recommendations.

Notes: Required vertical clearance above the unit is 36" (914 mm). There should be no piping or conduit located over the compressor motor. If the room configuration requires a variance to the clearance dimensions, contact your Trane sales office representative.

Installation: Mechanical

Figure 13. Recommended operating and service clearances – Model CVGF with unit-mounted starters

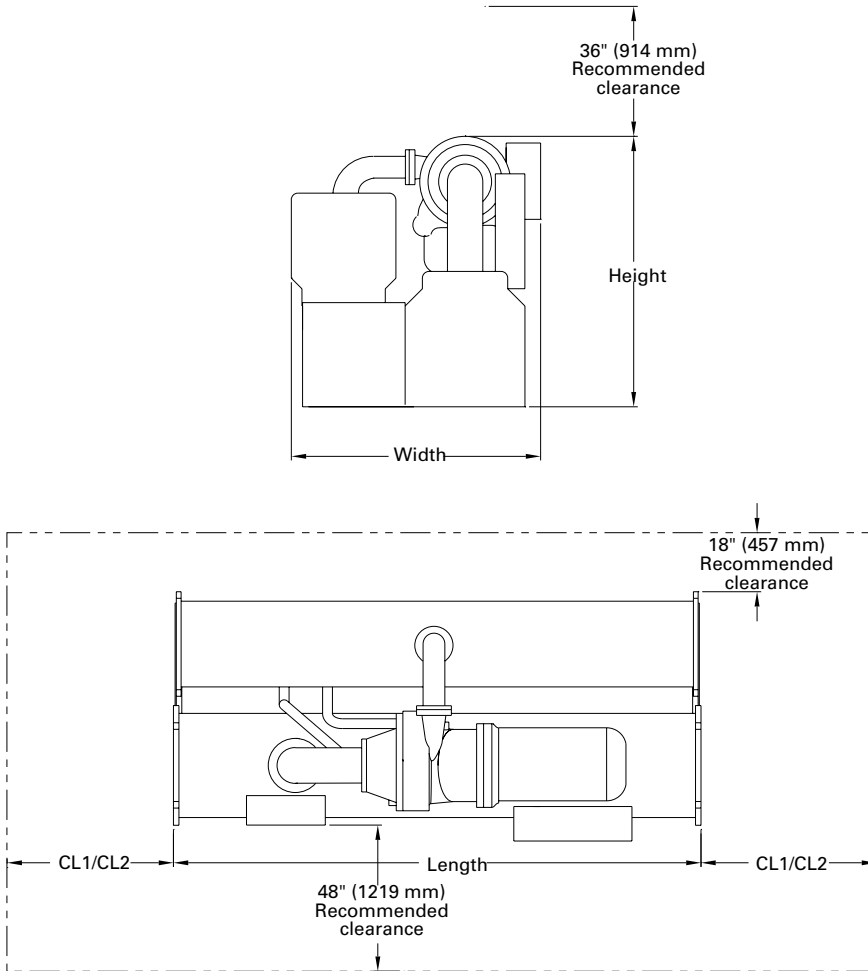

Table 7. Dimensions for figure 13

Compressor	Shell Size	Clearance Tube Pull		Unit Dimensions With Unit Mounted Starters		
		CL1	CL2	Length	Height	Width
400-500	500	13' 11" (4.235)	3' 7" (1.092)	13' 5" (4.083)	6' 11" (1.790)	6' 6" (1.984)
560-700	700	13' 11" (4.235)	3' 7" (1.092)	13' 5" (4.083)	6' 11" (1.790)	6' 10" (2.083)
740-1000	1000	13' 11" (4.235)	3' 7" (1.092)	13' 5" (4.083)	8' 4" (2.540)	7' 6-3/4" (2.305)

Notes:

CL1 at either end of the machine and is required for tube pull clearance.

CL2 is always at the opposite end of the machine from CL1 and is required for service clearance.

Add 14-5/8" (37.1 cm) on each end for the water box.

Figure 14. Recommended operating and service clearances – Model CVGF without unit-mounted starters

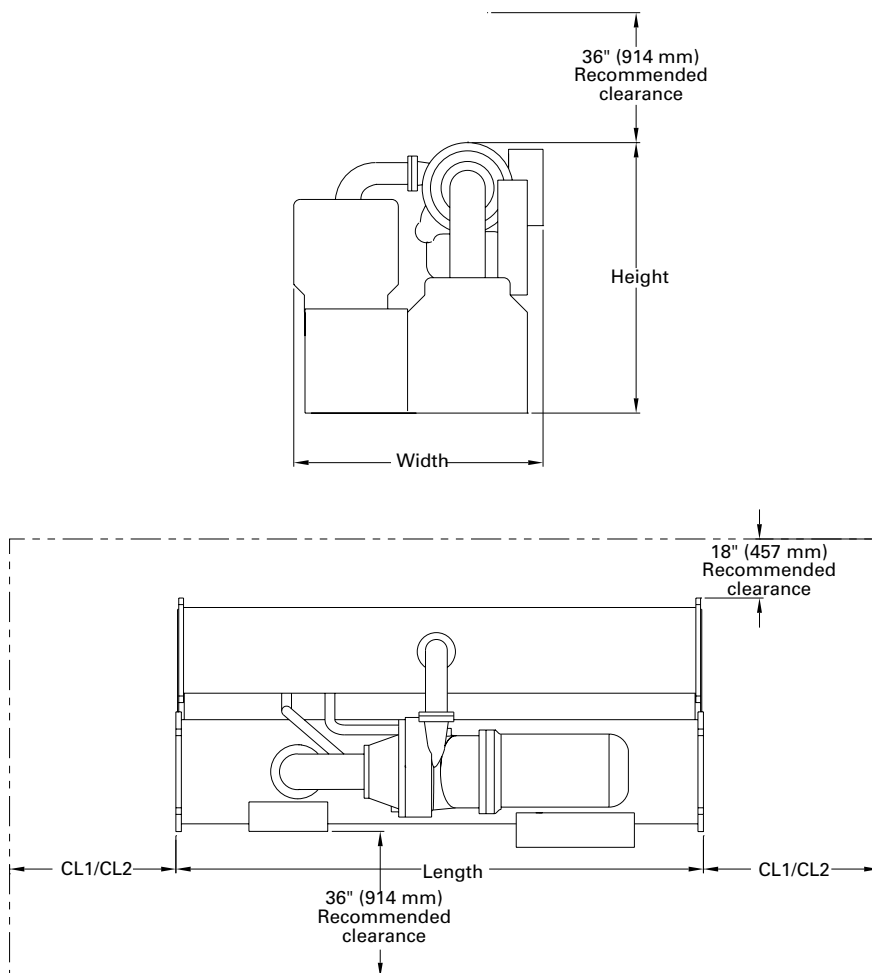

Table 8. Dimensions for figure 14

Compressor	Shell Size	Clearance Tube Pull		Unit Dimensions Without Unit Mounted Starters		
		CL1	CL2	Length	Height	Width
400-500	500	13' 11" (4.235)	3' 7" (1.092)	13' 5" (4.083)	6' 11" (1.790)	6' 3" (1.913)
560-700	700	13' 11" (4.235)	3' 7" (1.092)	13' 5" (4.083)	6' 11" (1.790)	6' 7" (2.028)
740-1000	1000	13' 11" (4.235)	3' 7" (1.092)	13' 5" (4.083)	8' 4" (2.540)	7' 5" (2.261)

Notes:

CL1 at either end of the machine and is required for tube pull clearance.

CL2 is always at the opposite end of the machine from CL1 and is required for service clearance.

Add 14-5/8" (37.1 cm) on each end for the water box.

Water Pipe Connections

Table 9 applies to all CVGF chiller tonnage sizes 500, 700 and 1000.

Refer to Table 9 for water pipe connection sizing information and evaporator and condenser water pass information. All measurement are in either US or metric equivalents.

Ventilation

The unit produces heat even though the compressor is cooled by the refrigerant. Make provisions to remove heat generated by unit operation from the equipment room. Ventilation must be adequate to maintain an ambient temperature lower than 122°F (50°C).

Vent the unit pressure relief valves in accordance with all local and national codes. Make provisions in the equipment room to keep the chiller from being exposed to freezing temperatures of 32°F(0°C).

Table 9. Model CVGF water connection pipe size (mm)

	Shell Size		
	500	700	1000
Water Passes	Nominal Pipe Size (inches) NPS		
Evaporator			
2-pass	8" (DN200)	10" (DN250)	12" (DN300)
3-pass	8" (DN200)	8" (DN200)	10" (DN250)
Condenser			
2-pass	10" (DN250)	12" (DN300)	14" (DN350)

Water Drainage

Locate the unit near a largecapacity drain for water vessel drain-down during shut-down or repair. Condensers and evaporators are provided with drain connections. All local and national codes apply.

Moving and Rigging

The Model CVGF chiller should be moved by lifting at designated lift points only. Refer to the rigging diagram that ships with each unit for specific per unit weight data.

⚠ WARNING **Heavy Objects!**

Do not use cables (chains or slings) except as shown. Each of the cables (chains or slings) used to lift the unit must be capable of supporting the entire weight of the unit. Lifting cables (chains or slings) may not be of the same length. Adjust as necessary for even unit lift.

Other lifting arrangements may cause equipment or propertyonly damage. Failure to properly lift unit may result in death or serious injury. See details below:

- Follow the procedures and diagrams in this manual and in the submittal.
- Always use lifting equipment with a capacity exceeding the unit lifting weight by an adequate safety factor. (+10%).

Chiller Isolation

To minimize sound and vibration transmission through the building structure, and to assure proper weight distribution over the mounting surface, install isolation pads or spring isolators under the chiller feet.

Note: Isolation pads are provided with each chiller unless spring isolators are specified on the sales order.

Specific isolator loading data is provided in the unit submittal package. Also refer to Table 10. If necessary, contact your local Trane sales office for further information.

Isolation Pads

When the unit is ready for final placement, position isolation pads end-to-end under the full length of the chiller leg. The pads measure 6" x 18" (152 x 457mm). See Figure 15. No gaps should be present between pads.

Remember that the chiller must be level within 1/4" (6 mm) over its length and width after it is lowered onto the isolation pads. In addition, all piping connected to the chiller must be properly isolated and supported so that it does not place any stress on the unit.

Figure 15. Isolation pad

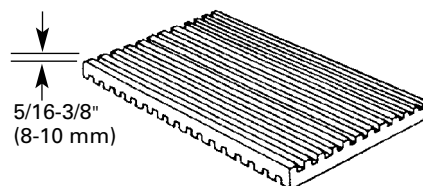

Spring Isolators

Spring isolators should be considered whenever chiller installation is planned for an upper-story location. Spring isolator selection and placement information is presented in Figure 16 and Figure 17.

Note: Three types of spring isolators, shown in Tables 11-13 are used. Each type has its own maximum loading characteristics.

Spring isolators are typically shipped assembled and ready for installation. To install and adjust the isolators properly, follow the instructions given.

Note: Do not adjust the isolators until the chiller is piped and charged with refrigerant and water.

1. Position the spring isolators under the chiller as shown in Figure 16 and Figure 18. Make sure that each isolator is centered in relation to the tube sheet.
2. Set isolators on the sub-base; shim or grout them as necessary to provide a flat, level surface as the same elevation for all mountings. Be sure to support the full underside of the isolator base plate; do not straddle gaps or small shims.
3. If required, bolt the isolators to the floor through the slots provided, or cement the pads.

Note: fastening the isolators to the floor is not necessary unless specified.

4. If the chiller must be fastened to the isolators, insert cap screws through the chiller base and into the holes tapped in the upper housing of each isolator. Do not allow the screws to protrude below the underside of the isolator upper housing. An alternative method of fastening the chiller to the isolators is to cement the neoprene pads.
5. Set the chiller on the isolators; refer to the "Rigging" section for lifting instructions.

Installation: Mechanical

The weight of the chiller will force the upper housing of each isolator down, perhaps causing it to rest on the isolator's lower housing. Figure 18 illustrates spring isolator construction.

6. Check the clearance on each isolator. If this dimension is less than 1/4" (6 mm) on any isolator, use a wrench to turn the adjusting bolt one complete revolution upward. Repeat this operation until a 1/4" (6 mm) clearance is obtained at all isolators.
7. After the minimum required clearance is obtained on each of the isolators, level the chiller by turning the adjusting bolt on each of the isolators on the low side of the unit. Be sure to work from one isolator to the next.

Remember that the chiller must be level to within 1/4" (6mm) over its length and width and that clearance of each isolator must be 1/4" (6 mm).

Figure 16. Chiller foot or isolator orientation

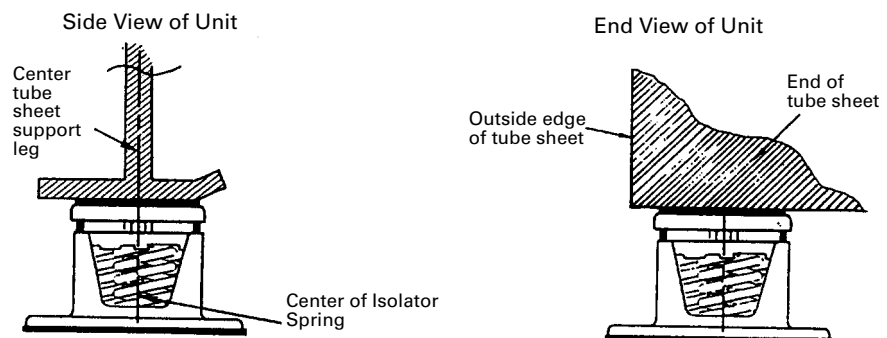

Note: The spring isolator must be centered in relation to the tube sheet. Do **not** align the isolator with the flat part of the chiller foot, because the tube sheet is often off-center.

Note: Place isolator near outside edge of tube sheet as shown.

Figure 17. Typical spring isolator construction

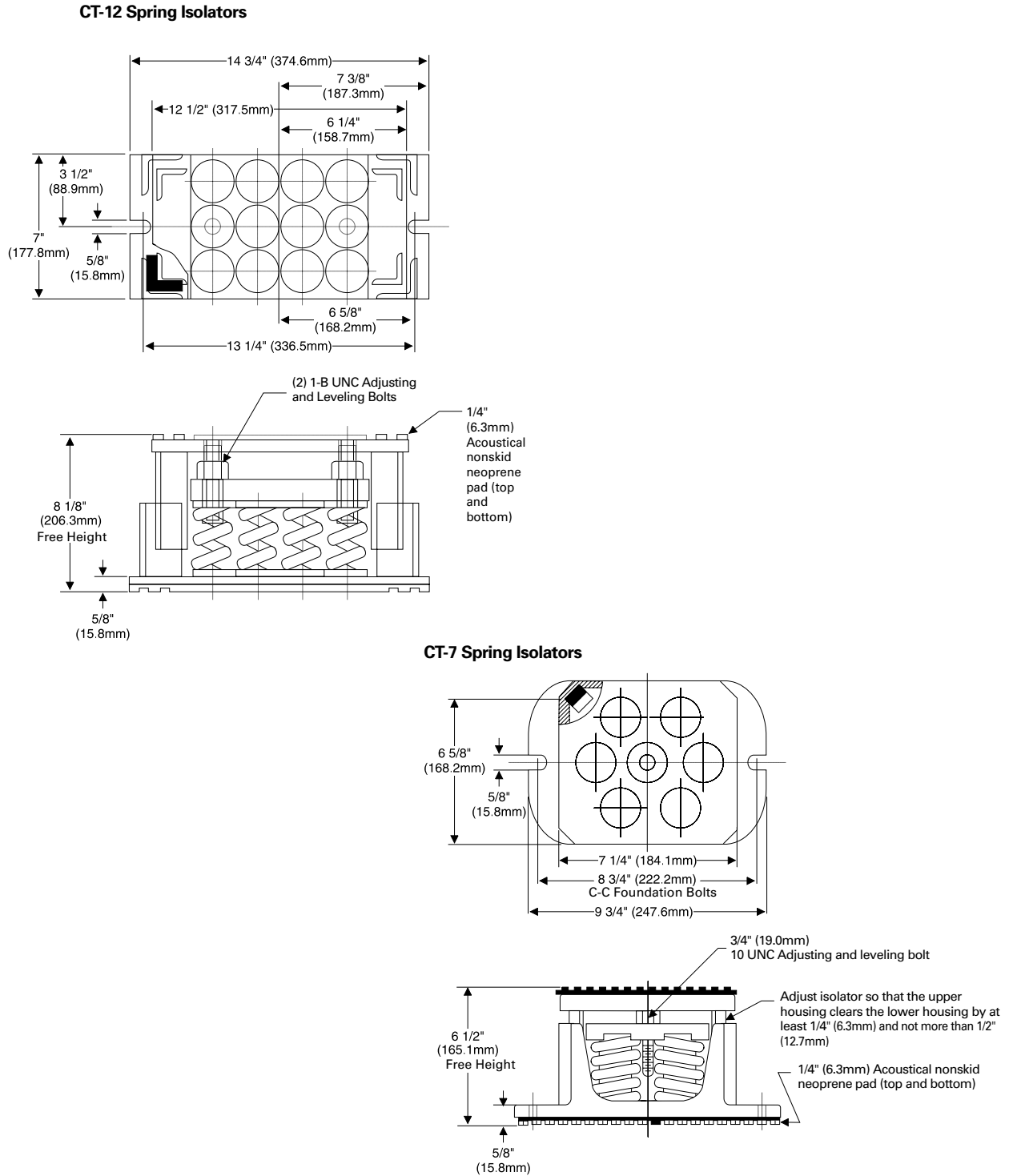

Installation: Mechanical

Table 10. Isolation loads - 500, 700 and 1000 ton families (reference figure 9)

Location Point	500 Ton Family Maximum Load - pound (kg)	700 Ton Family Maximum Load - pound (kg)	1000 Ton Family Maximum Load - pound (kg)
A	5905 (2679)	8388 (3805)	10750 (4846)
B	7005 (3177)	9431 (4278)	12665 (5745)
C	6090 (2762)	8991 (4078)	11500 (5216)
D	7225 (3277)	10340 (4690)	13545 (6144)

Table 11. Selected spring isolators – CVGF 500

Isolator type and size	Trane Part #	Maximum Load lbm (kg)	Deflection inches (mm)	Spring Color Coding	Location Used
CT-7-31	X10350664-050	7700 (3492.7)	0.83 (21)	Gray	A, B, C, D

Note: Each type CT-7 spring isolator has 7 springs.

Table 12. Selected spring isolators – CVGF 700

Isolator type and size	Trane Part #	Maximum Load lbm (kg)	Deflection inches (mm)	Spring Color Coding	Location Used
CT-12-27	X10350665-030	9000 (4082)	1.06 (27)	Orange	A & C
CT-12-28	X10350665-040	10800 (4898.8)	1.02 (26)	Green	B & D

Note: Each type CT-12 spring isolator has 12 springs.

Table 13. Selected spring isolators – CVGF 1000

Isolator type and size	Trane Part #	Maximum Load lbm (kg)	Deflection inches (mm)	Spring Color Coding	Location Used
CT-12-28	X10350665-040	10000 (4535.9)	1.02 (26)	Green	A
CT-12-31	X10350665-050	13200 (5987.4)	0.83 (21)	Gray	B, C, D

Note: Each type CT-12 spring isolator has 12 springs.

Figure 18. Load points - 500, 700 and 1000 ton families (reference table 10)

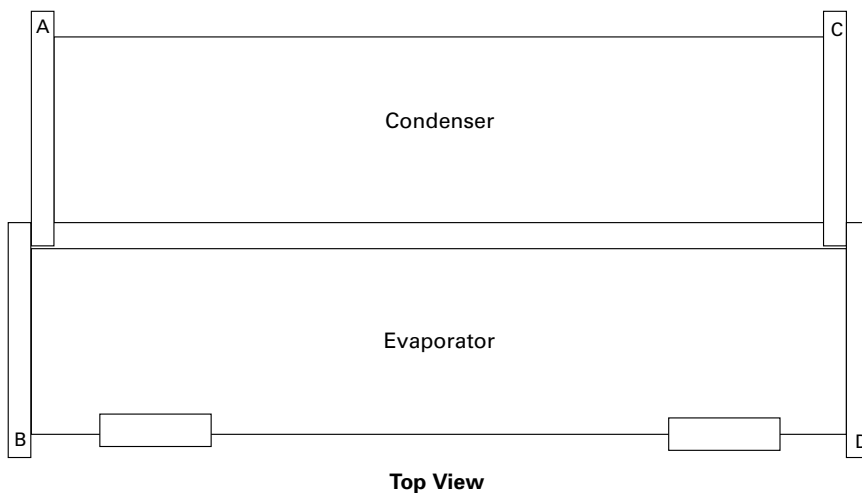

CVGF Rigging

1. Dimensions are in millimeters (mm). Figure 19.

⚠ WARNING
Heavy Objects!

Do not use cables (chains or slings) except as shown. Each of the cables (chains or slings) used to lift the unit must be capable of supporting the entire weight of the unit. Lifting cables (chains or slings) may not be of the same length. Adjust as necessary for even unit lift.

Other lifting arrangements may cause equipment or property damage. Failure to properly lift unit may result in death or serious injury. See details below.

1. Use a 3600 mm lifting beam and adjust the chains (cables) for an even, level lift.
2. 900 mm recommended clearance above highest point of compressor.
3. Attach safety chains or cables as shown, and without tension. The safety chain is not used for lifting, but is there to prevent the unit from rolling.
4. More details weight information is available on request.

2. Each chain or cable used to lift the unit must be capable of supporting the entire weight of the chiller.

3. Use a 3600 mm lifting beam and adjust the chains or cables for an even, level lift.
4. 900 mm recommended clearance above highest point of compressor.
5. Attach safety chains or cables as shown in Figure 20, and without tension. The safety chain is not used for lifting, but is there to prevent the unit from rolling.
6. More detailed weight information is available upon request.

Figure 19. Rigging diagram with anchor hole and bolt detail

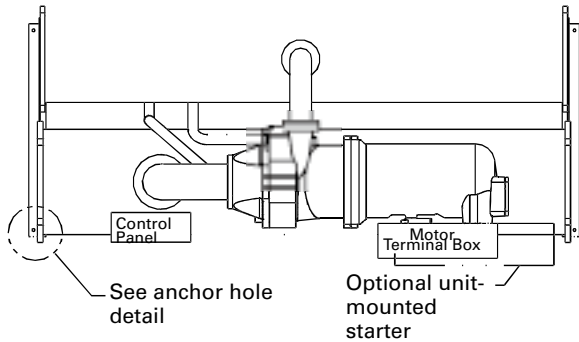

Anchor Bolt Detail

Nuts should not be tight. Leave 2 to 3 mm gap.

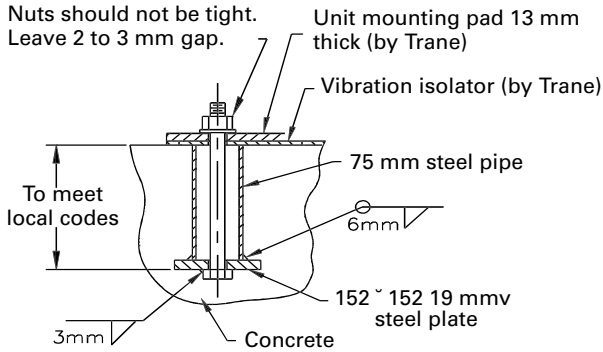

Recommended procedure to allow for thermal expansion. (Unless otherwise specified, parts are furnished by the customer.)

Figure 20. Rigging diagram with safety chain placement

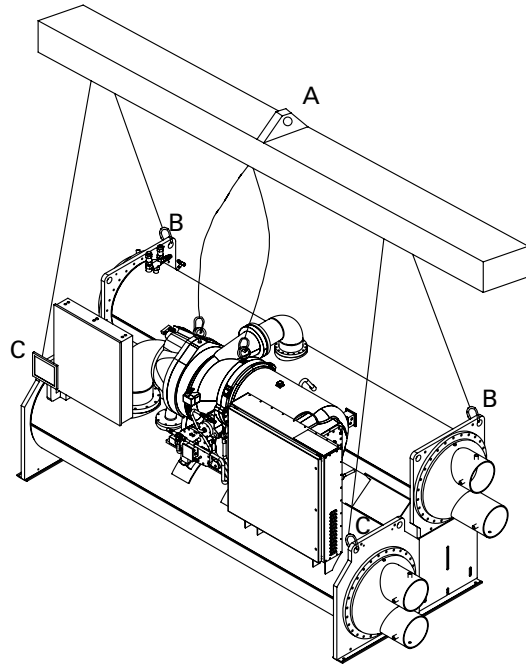

Anchor Hole Detail

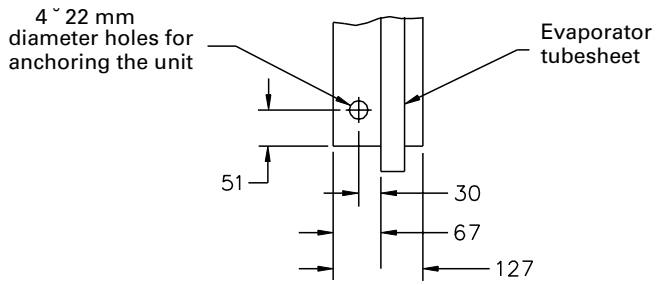

Dimensions are typical for each corner

CVGF Waterbox Removal and Installation

Introduction

The purpose of this bulletin is to communicate waterbox weights, recommended connection devices, and connection and lifting arrangements for CVGF gear-driven centrifugal chillers.

Important

Only qualified technicians should perform the installation and servicing of equipment referred to this bulletin.

Discussion

This bulletin will discuss recommended hoist ring/clevises and lifting. Proper lifting technique will vary based on mechanical room layout.

- It is the responsibility of the person(s) performing the work to be properly trained in the safe practice of rigging, lifting, securing, and fastening the of water box.
- It is the responsibility of the person(s) providing and using the rigging and lifting devices to inspect these devices to insure they are free from defect and are rated to meet or exceed the published weight of the waterbox.
- Always use rigging and lifting devices in accordance with the applicable instructions for such device.

Procedure

⚠ WARNING **Heavy Objects!**

Each of the individual cables (chains or slings) used to lift the waterbox must be capable of supporting the entire weight of the waterbox. The cables (chains or slings) must be rated for overhead lifting applications with an acceptable working load limit. Failure to properly lift waterbox could result in death or serious injury.

⚠ WARNING **Eyebolts!**

The proper use and ratings for eyebolts can be found in ANSI/ASME standard B18.15 or in European standard EN1677-1 and EN ISO 3266. Maximum load rating for eyebolts are based on a straight vertical lift in a gradually increasing manner. Angular lifts will significantly lower maximum loads and should be avoided whenever possible. Loads should always be applied to eyebolts in the plane of the eye, not at some angle to this plane. Failure to properly lift waterbox could result in death or serious injury. Review mechanical room limitations and determine the safest method or methods of rigging and lifting the waterboxes.

1. Determine the type and size of chiller being serviced. Refer to Trane Nameplate located on chiller control panel.

Important: This bulletin contains rigging and lifting information for Trane CVGF gear-driven centrifugal chillers built in Taicang China only. For Trane chillers built outside China, refer to literature provided by the applicable manufacturing location.

2. Select the proper lift connection device from Table 15. The rated lifting capacity of the selected lift connection device must meet or exceed the published weight of the waterbox.
3. Insure the lift connection device has the correct connection for the waterbox. Example: thread type (coarse/fine, English/metric). Bolt diameter (English/metric).
4. Properly connect the lift connection device to the waterbox. Refer to Figure 21. Insure lift connection device is securely fastened.

Installation: Mechanical

4. Install hoist ring on to the lifting connection on the waterbox. Torque to 135 Nm (100 ft-lbs) for M20x2.5 (mm) threaded connection, and 37Nm (28 ft-lbs) for M12 x1.75 (mm) threaded connection.
5. Disconnect water pipes, if connected.
6. Remove waterbox bolts.
7. Lift the waterbox away from the shell.

Figure21: Water Box Rigging and Lifting – Vertical Lift Only

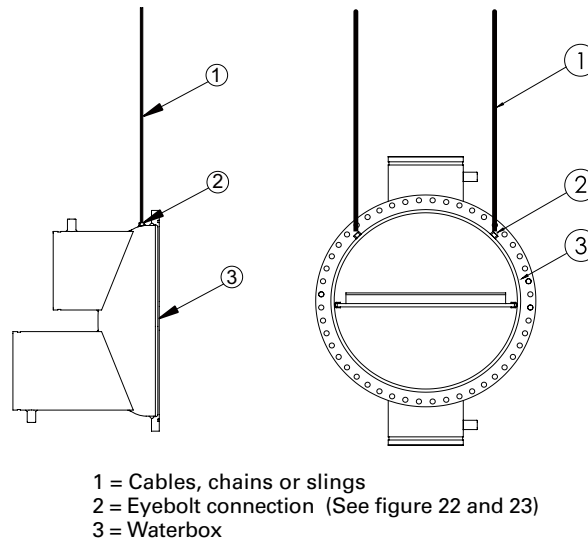

⚠ WARNING

OVERHEAD HAZARD

Never stand below or in close proximity to heavy objects while they are suspended from, or being lifted by, a lifting device. Failure to follow these instructions could result in death or serious injuries.

8. Store waterbox in a safe and secure location and position.
Do not leave waterbox suspended from lifting device.

Reassembly

Once service is complete the waterbox should be reinstalled on the shell following all previous procedures in reverse. Use new o-rings or gaskets on all joints after thoroughly cleaning each joint.

9. Torque waterbox bolts.

Torque bolts in a star pattern. Refer to Table 14 for torque values.

Table 14. CVGF Torque

Unit	Bolt Size(mm)	Evaporator	Condenser
CVGF	M16x2.0	203Nm (150 ft-lbs)	203Nm (150 ft-lbs)

Parts Ordering Information

This Bulletin is informational only and does not authorize any parts or labor. Use the Table 15 for part ordering information.

Table 15. Connection devices

Unit	Product	Rated Capacity	Part Number
CVGF	Safety Hoist Ring M12x1.75	674kg	RNG00003C (See figure 22)
	Safety Hoist Ring M20x2.5	2143kg	RNG00004C (See figure 23)

Figure 22: Eyebolt connection (Safety hoist ring M12X1.75)

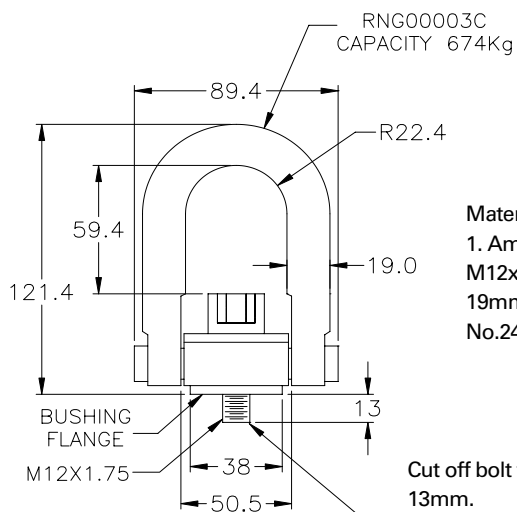

Material list
 1. American drill bushing (adb),
 M12x1.75 thread, Safety hoist ring,
 19mm effective thread length, part
 No.24012, Rated 1050kg.

Cut off bolt to an effective thread length of 13mm.
 Note: capacity is derated from manufacturer rating, Because of decreased effective thread length.

Figure 23 : Eyebolt connection (Safety hoist ring M20X2.5)

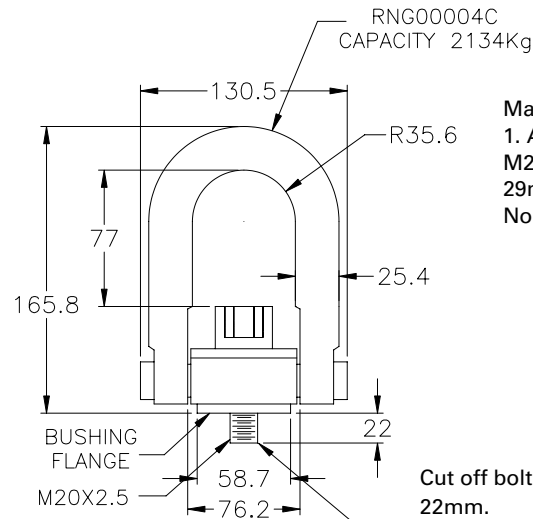

Material list

1. American drill bushing (adb), M20x2.5 thread, Safety hoist ring, 29mm effective thread length, part No.24022, Rated 3000kg.

Cut off bolt to an effective thread length of 22mm.

Note: capacity is derated from manufacturer rating, Because of decreased effective thread length

⚠ WARNING

Safety Hoist Ring Modification

The modification shown in Figure 22 and Figure 23 must be complete prior to using the hoist ring to lift the waterbox. Failure to make these modification could result in death or serious injuries.

The length of the standard hoist ring bolt must be shortened (modified) prior to use for lifting waterboxes. Shorting of the bolt as instructed will help insure the base of the hoist right is flat against the waterbox when properly seated. If bases of hoist is not properly seated against waterbox side loading on the bolt may occur which could lead to bolt failure.

Table 16. CVGF Waterbox Weights

Shell Size	Description	Domed Non-Marine Waterbox, Welded Flat Plate			Fabricated Marine Style Waterbox			Fabricated Marine Style Waterbox Cover		
		Weight Kg (Lbs)		Lifting Connection	Weight Kg (Lbs)		Lifting Connection	Weight Kg (Lbs)		Lifting Connection
500	Evaporator 150Psi	102	(225)	M12X1.75	217	(479)	M20X2.5	155	(342)	M12X1.75
	Evaporator 300Psi	119	(263)	M20X2.5	257	(567)	M20X2.5	214	(472)	M12X1.75
	Condenser 150Psi	116	(256)	M12X1.75	234	(516)	M20X2.5	155	(342)	M12X1.75
	Condenser 300Psi	134	(296)	M20X2.5	275	(607)	M20X2.5	214	(472)	M12X1.75
700	Evaporator 150Psi	149	(329)	M12X1.75	279	(616)	M20X2.5	220	(486)	M12X1.75
	Evaporator 300Psi	185	(408)	M20X2.5	330	(728)	M20X2.5	312	(688)	M12X1.75
	Condenser 150Psi	160	(353)	M12X1.75	312	(688)	M20X2.5	220	(486)	M12X1.75
	Condenser 300Psi	199	(439)	M20X2.5	370	(816)	M20X2.5	312	(688)	M12X1.75
1000	Evaporator 150Psi	218	(481)	M20X2.5	454	(1001)	M20X2.5	313	(691)	M12X1.75
	Evaporator 300Psi	292	(644)	M20X2.5	590	(1301)	M20X2.5	531	(1171)	M20X2.5
	Condenser 150Psi	261	(576)	M20X2.5	519	(1145)	M20X2.5	313	(691)	M12X1.75
	Condenser 300Psi	432	(953)	M20X2.5	709	(1564)	M20X2.5	513	(1131)	M20X2.5

Refer to product block identifier on the model number plate which identifies the evaporator and condenser shell sizes and the rated pressure. The designators are as follows:

Evaporator Size = EVSZ Condenser Size = CDSZ Evaporator Pressure = EVPR Condenser Pressure = CDPR

Weights shown are maximum for waterbox size. Verify the waterbox from the latest published literature.

Installation: Mechanical

Water Pressure Drop Data

Graph 1.

Pressure drop for CVGF 500 Evaporators with 0.75 inch OD tubes and 2 pass waterboxes

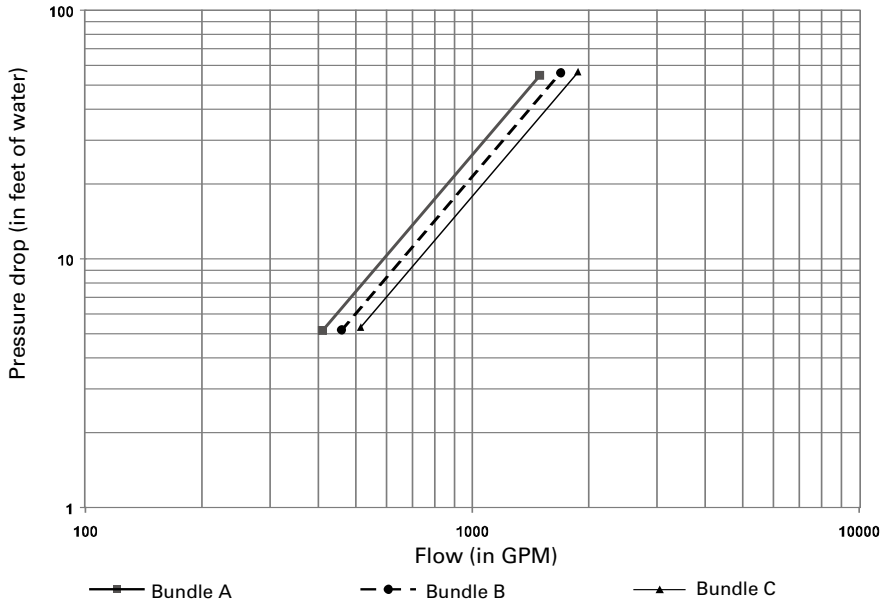

Graph 2.

Pressure drop for CVGF 500 Condensers with 0.75 inch OD tubes and 2 pass waterboxes

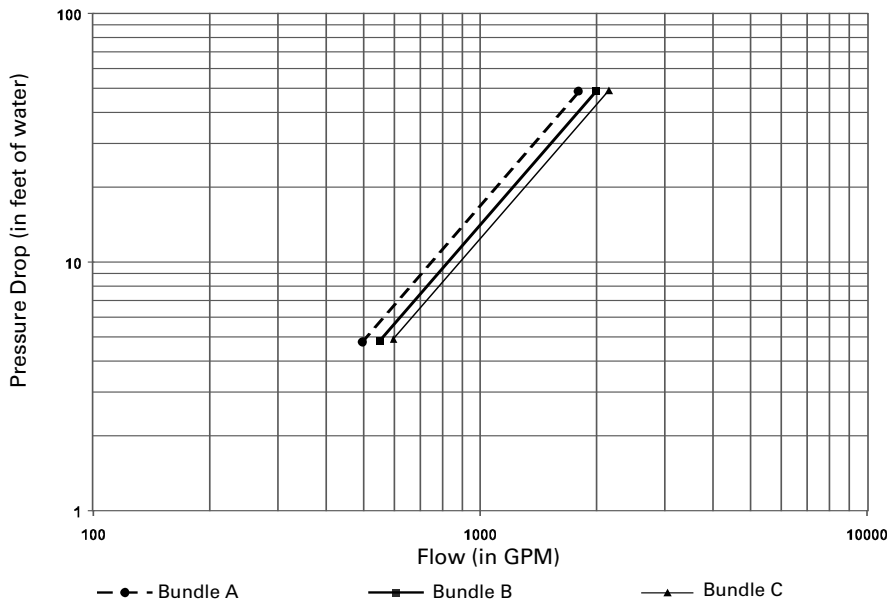

Water Pressure Drop Data

Graph 3.

Pressure drop for CVGF 500 Evaporators with 1.0 inch OD tubes and 2 pass waterboxes

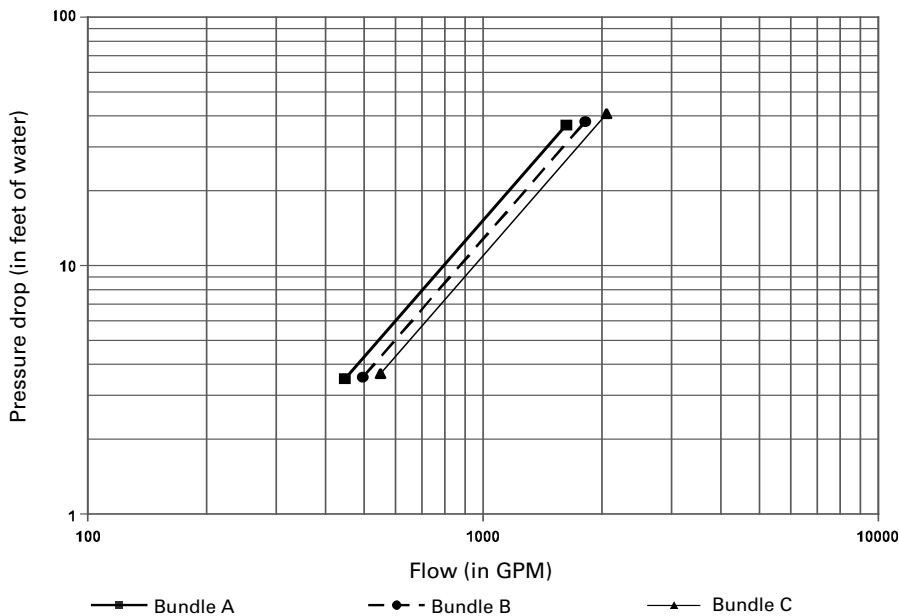

Graph 4.

Pressure drop for CVGF 500 Condensers with 1.0 inch OD tubes and 2 pass waterboxes

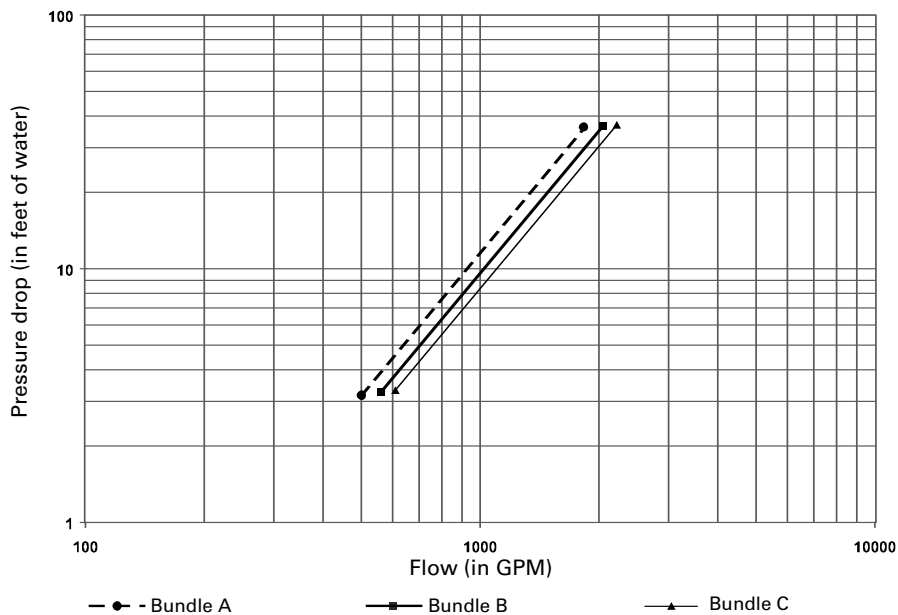

Installation: Mechanical

Water Pressure Drop Data

Graph 5.

Pressure drop for CVGF 700 Evaporators with 3/4 inch OD tubes and 2 pass waterboxes

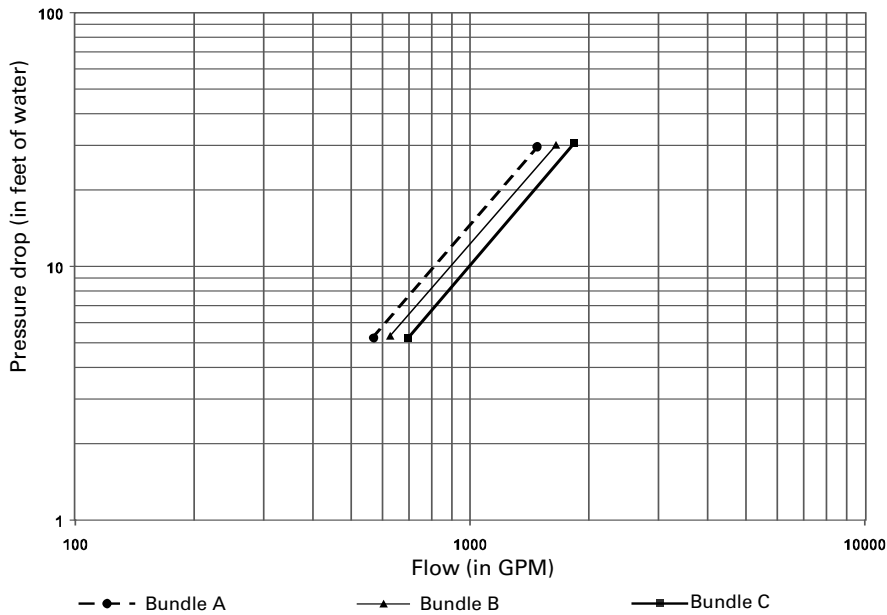

Graph 6.

Pressure drop for CVGF 700 Condensers with 3/4 inch OD tubes and 2 pass waterboxes

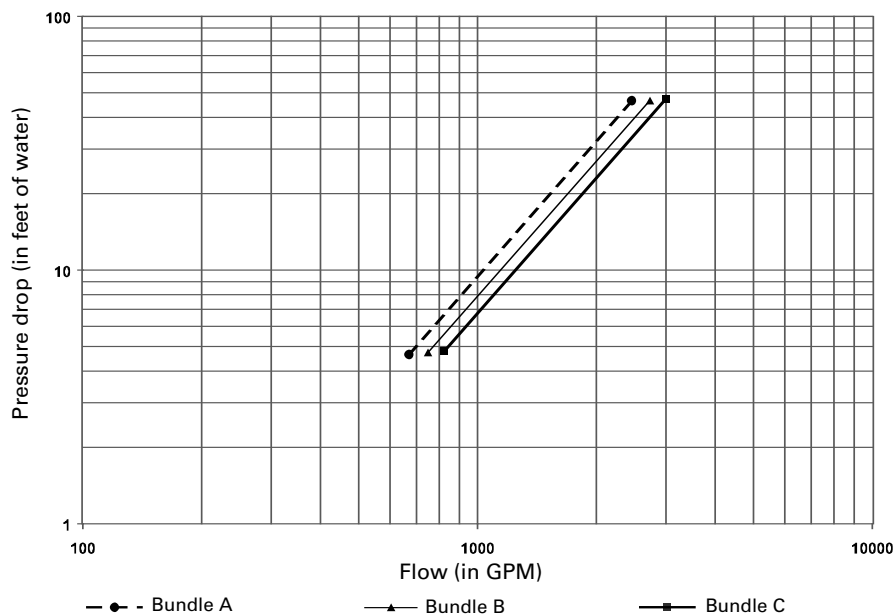

Water Pressure Drop Data

Graph 7.

Pressure drop for CVGF 700 Evaporators with 3/4 inch OD tubes and 3 pass waterboxes

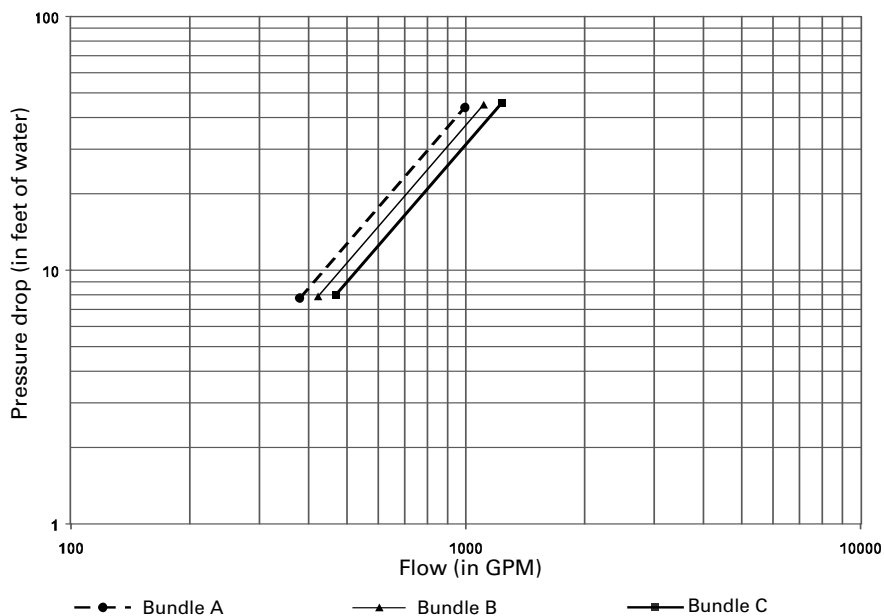

Graph 8.

Pressure drop for CVGF 700 Evaporators with 1.0 inch OD tubes and 2 pass waterboxes

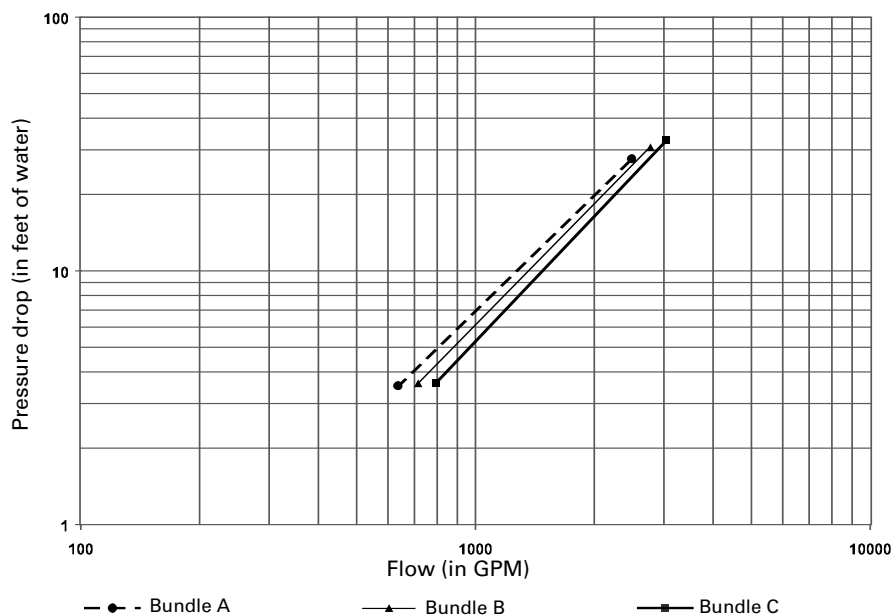

Installation: Mechanical

Water Pressure Drop Data

Graph 9.

Pressure drop for CVGF 700 Condensers with 1.0 inch OD tubes and 2 pass waterboxes

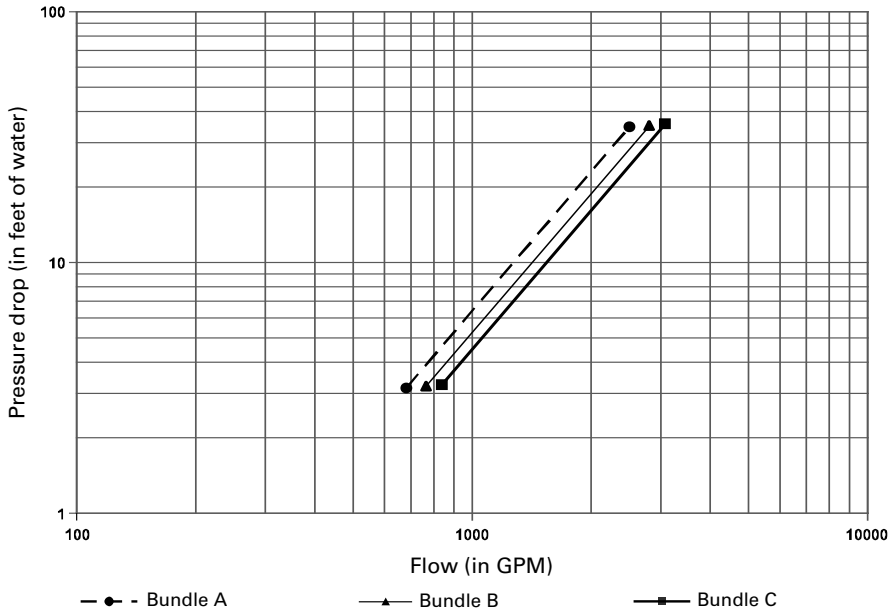

Graph 10.

Pressure drop for CVGF 700 Evaporators with 1.0 inch OD tubes and 3 pass waterboxes

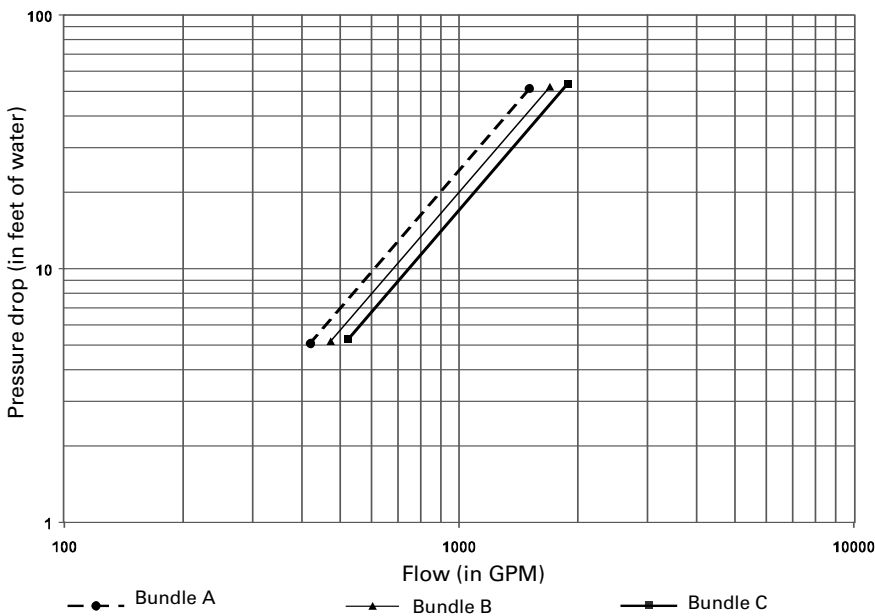

Water Pressure Drop Data
Graph 11.

Pressure drop for CVGF 1000 Evaporators with 3/4 inch OD tubes and 2 pass waterboxes

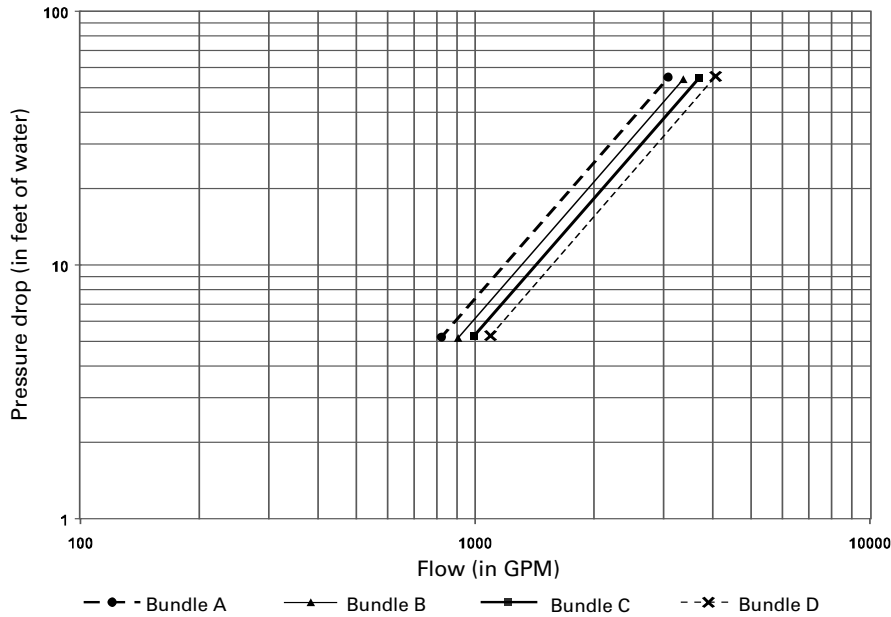

Graph 12.

Pressure drop for CVGF 1000 Evaporators with 3/4 inch OD tubes and 3 pass waterboxes

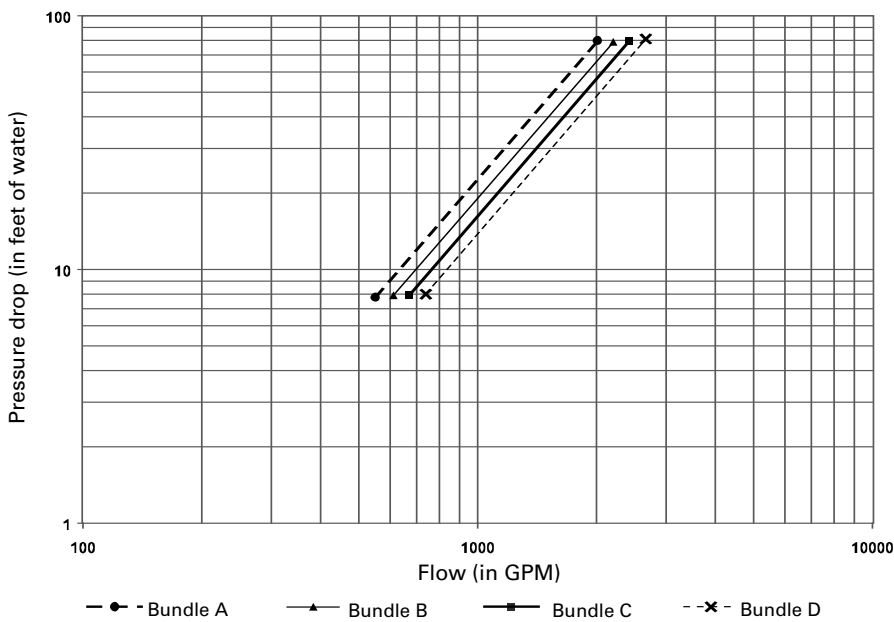

Water Pressure Drop Data

Graph 13.

Pressure drop for CVGF 1000 Condensers with 3/4 inch OD tubes and 2 pass waterboxes

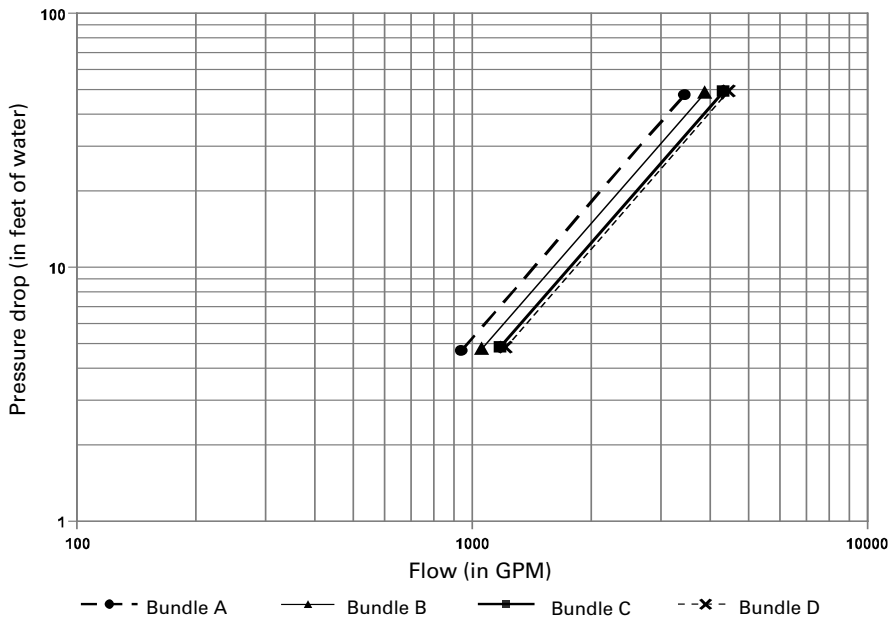

Graph 14.

Pressure drop for CVGF 1000 Evaporators with 1.0 inch OD tubes and 2 pass waterboxes

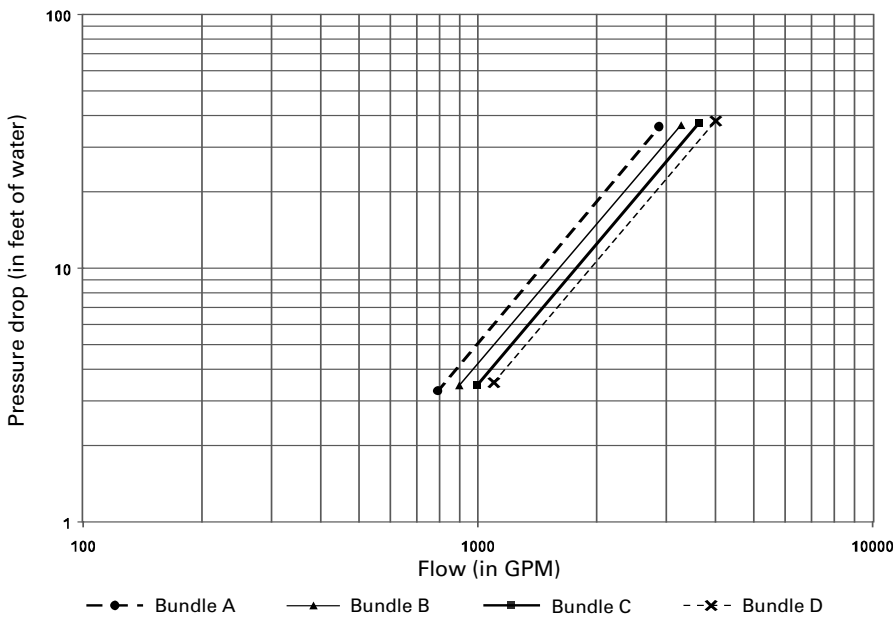

Water Pressure Drop Data

Graph 15.

Pressure drop for CVGF 1000 Condensers with 1.0 inch OD tubes and 2 pass waterboxes

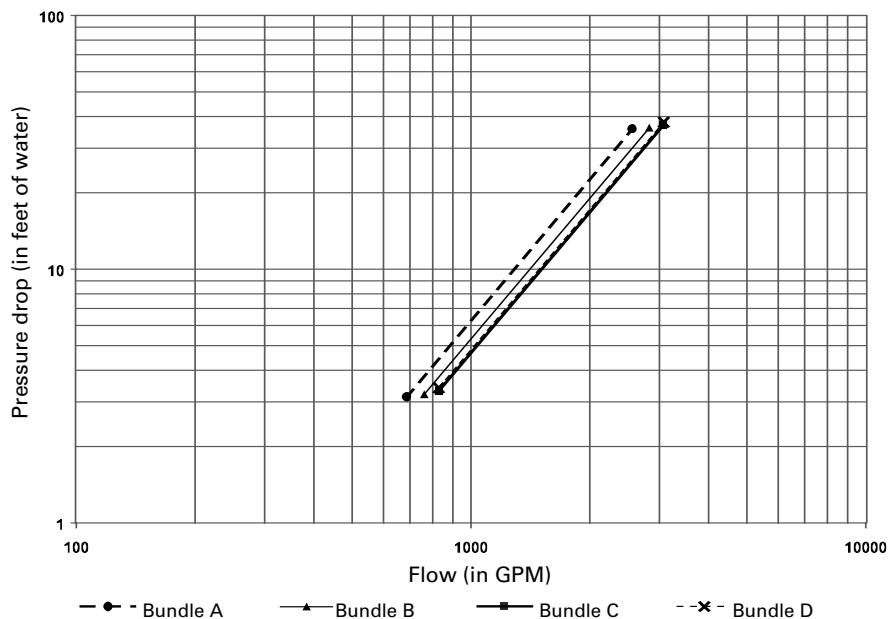

Graph 16.

Pressure drop for CVGF 1000 Evaporators with 1.0 inch OD tubes and 3 pass waterboxes

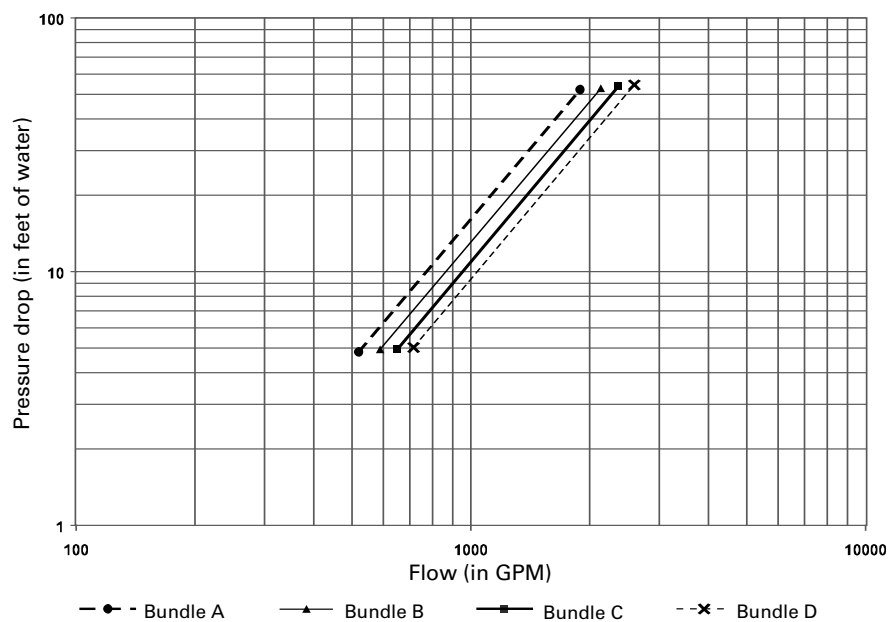

Connecting Groove Pipes

CAUTION

Piping damage!

To prevent damage to water piping, do not overtighten the connections.
Note: Make sure that all piping is flushed and cleaned prior to starting the unit.

CAUTION

Equipment damage!

To prevent equipment damage, bypass the unit if using an acidic flushing agent.

Vents and Drains

Install pipe plugs or ball valves, with National Pipe Thread (NPT) to water hose thread connections, in evaporator and condenser water box drain and vent connections before filling the water systems.

To drain water, remove the vent and drain plugs or open the ball valves. Install an NPT connectors in the drain connection, and connect a hose to it.

Evaporator Piping Components

Note: Ensure that all piping components are between the shutoff valves, so that both the condenser and the evaporator can be isolated.

Piping components include all devices and controls used to provide proper water-system operation and unit operating safety. These components and their general locations are described below.

Entering Chilled-Water Piping

- Air vents (to bleed air from system)
- Water pressure gauges manifolded with shutoff valves
- Pipe unions
- Vibration eliminators (rubber boots)
- Shutoff (isolation) valves
- Thermometers
- Cleanout tees
- Pipe strainer

Leaving Chilled-Water Piping

- Air vents (to bleed air from system)
- Water pressure gauges manifolded with shutoff valves
- Pipe unions
- Vibration eliminators (rubber boots)
- Shutoff (isolation) valves
- Thermometers
- Cleanout tees
- Balancing valve
- Pressure relief valve
- Flow switch

CAUTION**Equipment damage!**

To prevent evaporator damage, do not exceed 150 psig (1035 kPa) evaporator water pressure for standard water boxes. The maximum pressure for highpressure water boxes is 300 psig (2100 kPa). To prevent tube damage by erosion, install a strainer in the evaporator water inlet piping.

Condenser Piping Components

Piping components include all devices and controls used to provide proper water-system operation and unit operating safety. These components and their general locations are given below.

Entering condenser-water piping

- Air vents (to bleed air from system)
- Water pressure gauges manifolded with shutoff valves
- Pipe unions
- Vibration eliminators (rubber boots)
- Shutoff (isolation) valves, one per pass
- Thermometers
- Cleanout tees
- Pipe strainer

Leaving condenser-water piping

- Air vents (to bleed air from system)
- Water pressure gauges with manifolded shutoff valves
- Pipe unions
- Vibration eliminators (rubber boots)
- Shutoff (isolation) valves, one per pass
- Thermometers
- Cleanout tees
- Balancing valve
- Pressure relief valve
- Flow switch

CAUTION**Condenser damage!**

To prevent condenser damage, do not exceed 150 psig (1035 kPa) water pressure for standard water boxes. The maximum pressure for highpressure water boxes is 300 psig (2100 kPa).

To prevent tube damage, install a strainer in the condenser water inlet piping.

To prevent tube corrosion, ensure that the initial water fill has a balanced pH.

Water Treatment**CAUTION****Water Treatment!**

Do not use untreated or improperly treated water. Use of untreated or improperly treated water may result in equipment damage.

Using untreated or improperly treated water in these units may result in inefficient operation and possible tube damage.

Installation: Mechanical

Consult a qualified watertreatment specialist to determine whether treatment is needed. The following disclamatory label is provided on each CVGF unit:
 The use of improperly treated or untreated water in this equipment may result in scaling, erosion, corrosion, algae, or slime. The services of a qualified water-treatment specialist should be engaged to determine what treatment, if any, is advisable. The Trane Company warranty specifically excludes liability for corrosion, erosion, or deterioration of Trane equipment. Trane assumes no responsibility for the results of the use of untreated, improperly treated, saline, or brackish water.

Figure 24. Typical thermometer, valving, and manifold pressure gauge set-up

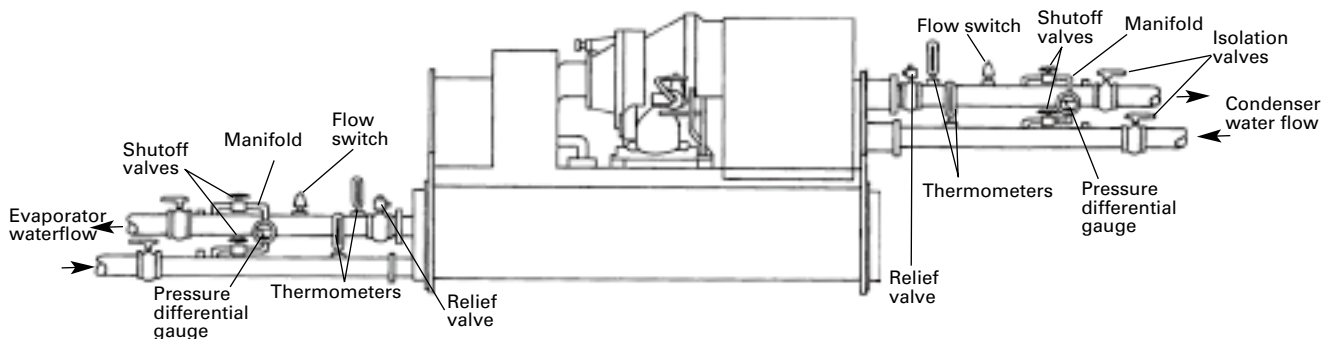

Water Pressure Gauges and Thermometers

Install field-supplied thermometers and pressure gauges (with manifolds whenever practical) as shown in

Figure 24. Locate pressure gauges or taps in a straight run of pipe; avoid placement near elbows, and so forth. Be sure to install the gauges at the same elevation on each shell if the shells have opposite-end water connections.

To read manifolded water pressure gauges, open one valve and close the other (depending upon the reading desired). This eliminates errors resulting from differently calibrated gauges installed at unmatched elevations.

Water Pressure-Relief Valves

CAUTION

Shell Damage!

Install a pressure-relief valve in both the evaporator and condenser water systems.

Failure to do so could result in shell damage.

Install a water pressure-relief valve in one of the condenser, and one of the evaporator, water box drain connections, or on the shell side of any shutoff valve.

Water vessels with closecoupled shutoff valves have a high potential for hydrostatic pressure buildup during a water temperature increase. Refer to applicable codes for pressurerelease valve installation guidelines.

Flow-Sensing Devices

Use field provided flow switches or differential pressure switches with pump interlocks

to sense system water flow. Flow switch locations are schematically shown in Figure 24.

To provide chiller protection, install and wire flow switches in series with the water pump interlocks, for both chilled-water and condenser-water circuits (refer to the Installation Electrical section). Specific connections and schematic wiring diagrams are shipped with the unit.

Flow switches must stop or prevent compressor operation if either system water flow drops below the required minimum that is shown on the pressure drop curves. Follow the manufacturer's recommendations for selection and installation procedures.

General guidelines for flow switch installation are outlined below.

- Mount the switch upright, with a minimum of 5 pipe diameters of straight, horizontal run on each side.
- Do not install close to elbows, orifices, or valves.

Note: The arrow on the switch must point in the direction of the water flow.

- To prevent switch fluttering, remove all air from the water system

Note: The AdaptiView provides a six-second time delay on the flow switch input before shutting down the unit on a loss-of-flow diagnostic. If machine shutdowns persist, contact your local Trane representative.

- Adjust the switch to open when water flow falls below nominal. Refer to the General Data tables for minimum flow recommendations for specific water-pass arrangements. Flow switch contacts are closed when there is proof of water flow.

Refrigerant Pressure-Relief Valve Venting

⚠ WARNING

Possible refrigerant asphyxiation!

Relief valve venting must be vented outdoors. Refrigerant is heavier than air and will displace available oxygen to breathe, causing asphyxiation or other health risks. Each chiller or Multiple chillers must have their own separate relief valves and vent piping. Consult local regulations for any special relieflines requirements. Failure to vent relief valves outdoors could result in death and serious injury.

Note: Vent pipe size must conform to the ANSI/ASHRAE Standard 15 for vent pipe sizing.

All country, federal, state, and local codes take precedence over any suggestions stated in this manual.

All relief valve venting is the responsibility of the installing contractor.

All CVGF units use evaporator and condenser pressure-relief valves that must be vented to the outside of the building.

Relief valve connection sizes and locations are shown in the unit submittals. Refer to local codes for relief valve vent line sizing information.

CAUTION

Do not exceed vent piping code specifications. Failure to heed specifications could result in capacity reduction, unit damage, and relief valve damage. After the relief valve has opened, it will reclose when pressure is reduced to a safe level.

Note: Relief valves tend to leak if they have opened and must be replaced.



Installation: Mechanical

Thermal Insulation

All CVGF units are available with optional factory installed thermal insulation. If the unit is not factory insulated, install insulation over the areas with designated dotted lines in Figure 25. Refer to Table 17 for types and quantities of insulation required. All CVGF units come from the factory with oil sump insulation.

Notes: Refrigerant charging valves, water temperature sensors, and drain and vent connections, when insulated, must remain accessible for service.

Use only water-base latex paint on factory applied insulation. Failure to do so may result in insulation shrinkage.

Note: Units in environments with higher humidity may require additional insulation.

Figure 25. Typical CVGF insulation requirements
Insulate where dotted lines are indicated.

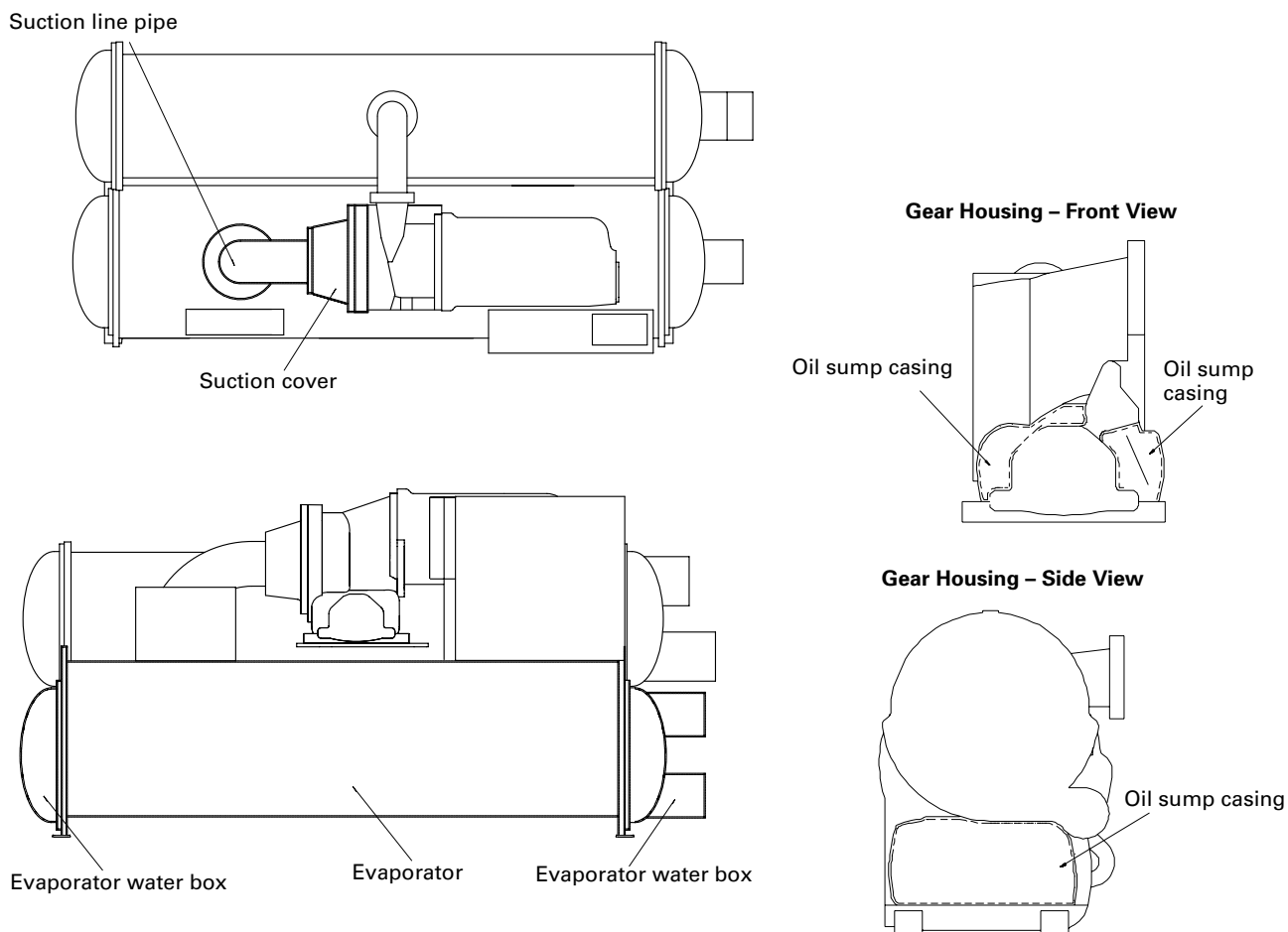

Table 17. Recommended insulation types

Location	Type	Square Feet (Square m)
Evaporator, waterboxes and tube sheets	3/4" wall (19 mm)	160 (15)
Compressor suction elbow and suction cover	3/4" wall (19 mm)	20 (2)
All components and piping on low side of system	3/4" wall (19 mm)	10 (1)



Installation: Electrical

General Requirements

⚠ WARNING

Live Electrical Components!

During installation, testing, servicing and troubleshooting of this product, it may be necessary to work with live electrical components. Have a qualified licensed electrician or other individual who has been properly trained in handling live electrical components perform these tasks. Failure to follow all electrical safety precautions when exposed to live electrical components could result in death or serious injury.

⚠ WARNING

Rotating Components!

During installation, testing, servicing and troubleshooting of this product it may be necessary to measure the speed of rotating components. Have a qualified or licensed service individual who has been properly trained in handling exposed rotating components, perform these tasks. Failure to follow all safety precautions when exposed to rotating components could result in death or serious injury.

As you review this manual, along with the wiring instructions presented in this section, keep in mind that:

All field-installed wiring must conform to National Electric Code (NEC) guidelines, as well as to any applicable state and local codes. Be sure to satisfy proper equipment grounding requirements per NEC.

All field-installed wiring must be checked for proper terminations, and for possible shorts or grounds.

Do not modify or cut enclosure to provide electrical access. Removable panels have been provided for this purpose. Modify these panels only; away from enclosure. Refer to installation information shipped with the starter or submittal drawings.

CAUTION

TO AVOID DAMAGE TO STARTER COMPONENTS,

remove debris inside the starter panel. Failure to do so may cause an electrical short that seriously damages the starter components.

Power Supply Wiring

To assure that power supply wiring to the starter panel is properly installed and connected, review and follow the guidelines outlined below.

3-Phase Power Source

1. Verify that the starter nameplate ratings are compatible with the power supply characteristics and with the electrical data on the unit nameplate.
2. If the starter enclosure must be cut to provide electrical access, exercise care to prevent debris from falling inside the enclosure. If the starter cabinet has a removable panel, be sure to remove the panel from the unit before drilling holes.

CAUTION

Damage to Starter components!

To avoid damage remove debris inside the starter panel. Failure to do so may cause an electrical short that seriously damages the starter components.

- Use copper conductors to connect the 3-phase power supply to the remote or unit-mounted starter panel.

CAUTION

Use Copper Conductors Only!

Unit terminals are not designed to accept other types of conductors. Failure to use copper conductors may result in equipment damage.

- Size the power supply wiring in accordance with the Minimum Circuit Ampacity (MCA) shown on the unit nameplate.

$$(MCA = (RLA \times 1.25) + \text{Control Power Load})$$

- Make sure that the incoming power wiring is properly phased; each power supply conduit run to the starter must carry the correct number of conductors to ensure equal phase representation. See Figure 26.

- As you install the power supply conduit, make sure that this position does not interfere with the serviceability of any of the unit components, nor with structural members and equipment.

Also, assure that the conduit is long enough to simplify any servicing that may be necessary in the future (for example, starter removal).

Note: Use flexible conduit to enhance serviceability and minimize vibration transmission.

Circuit Breakers and Fusible Disconnects

Size the circuit breaker or fuse disconnect in compliance with NEC or local guidelines.

Figure 26. Proper phasing for starter power supply wiring and conduit loading

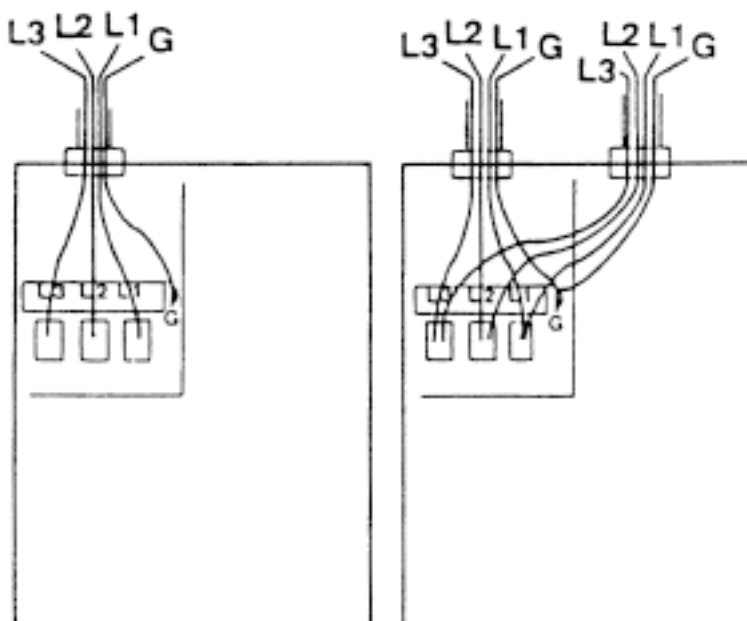



Optional PFCCs

Power factor correction capacitors (PFCCs) are designed to provide power factor correction for the compressor motor. They are available as an option.

Note: Remember that the PFCC nameplate voltage rating must be greater than or equal to the compressor voltage rating stamped on the unit nameplate. See Table 18 to determine what PFCC is appropriate for each compressor voltage application.

CAUTION

Motor of safety overload damage!

PFCC must be wired into the starter correctly. Failure to do so may cause misapplication of these capacitors and result in a loss of motor overload protection and subsequently cause motor damage.

Table 18. PFCC design voltage sizing per compressor voltage application

PFCC Design Voltage	Compressor Motor Rating (See Unit Nameplate)
480V/60 Hz	380V/60 Hz
	440V/60 Hz
	460V/60 Hz
	480V/60 Hz
600V/60 Hz	575V/60 Hz
	600V/60 Hz
2400V/60 Hz	2300V/60 Hz
	2400V/60 Hz

PFCC Rating	Compressor Motor Rating (See Unit Nameplate)
480V/50 Hz	346V/50 HZ
	380V/50 HZ
	400V/50 Hz
	415V/50 Hz
4160V/60 Hz	3300V/60 Hz
	4160V/60 Hz
	6600V/60 Hz
4160V/50 Hz	3300V/50 Hz
	6600V/50 Hz

Figure 27. PFCC leads routed through overload current transformer

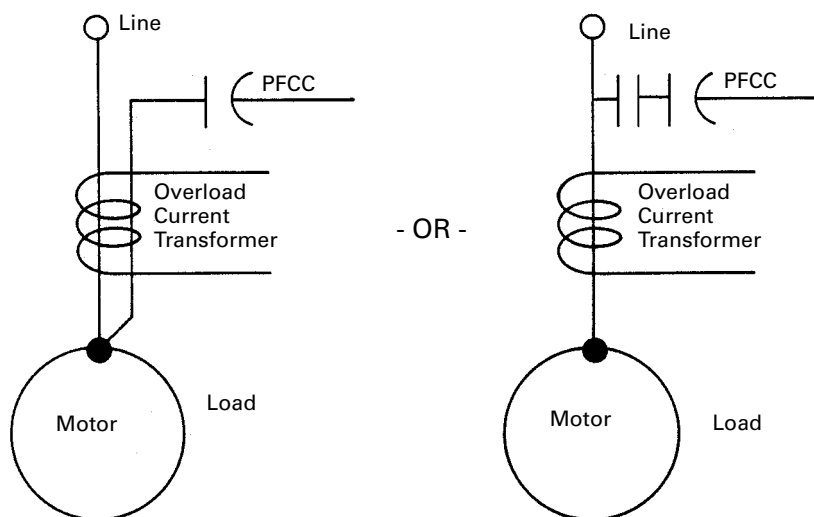

Note: See the attached wiring diagram for more detail.

Interconnecting Wiring

Typical equipment room conduit layouts with and without unit-mounted starters are shown in Figures 28 and 29, respectively.

IMPORTANT

Keep in mind that the interconnecting wiring between the starter panel, compressor and UCP control panel is factory-installed with unit-mounted starters but must be field-installed when a remotemounted starter is used.

Figure 28. Typical equipment room layout with unit-mounted, Wye-Delta

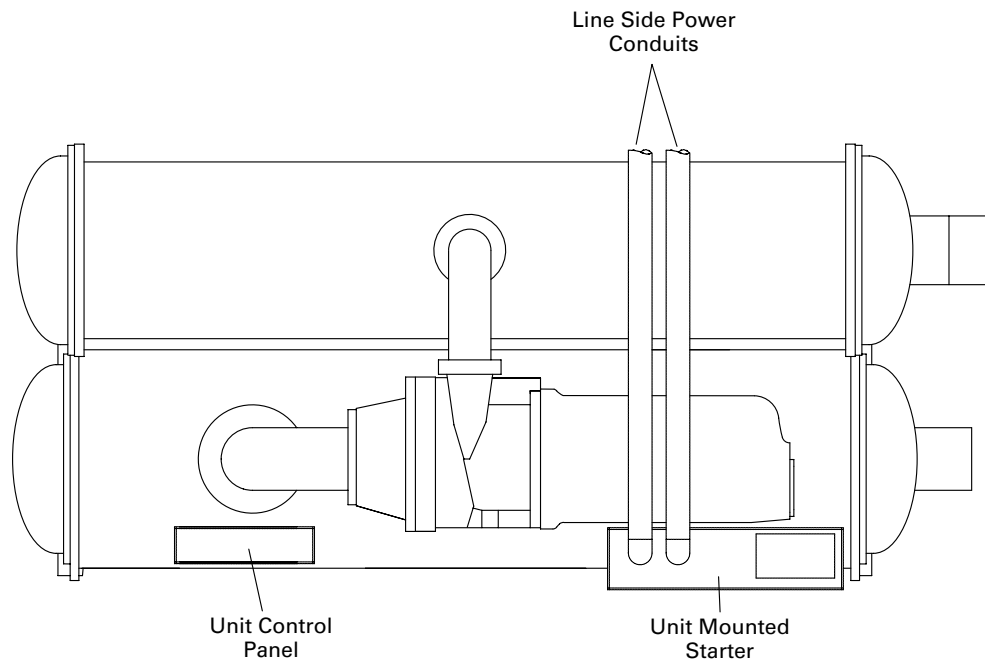

Note: See Starter submittal drawing for location of incoming wiring to the starter.

Figure 29. Typical equipment room layout with remote-mounted Wye-Delta starter

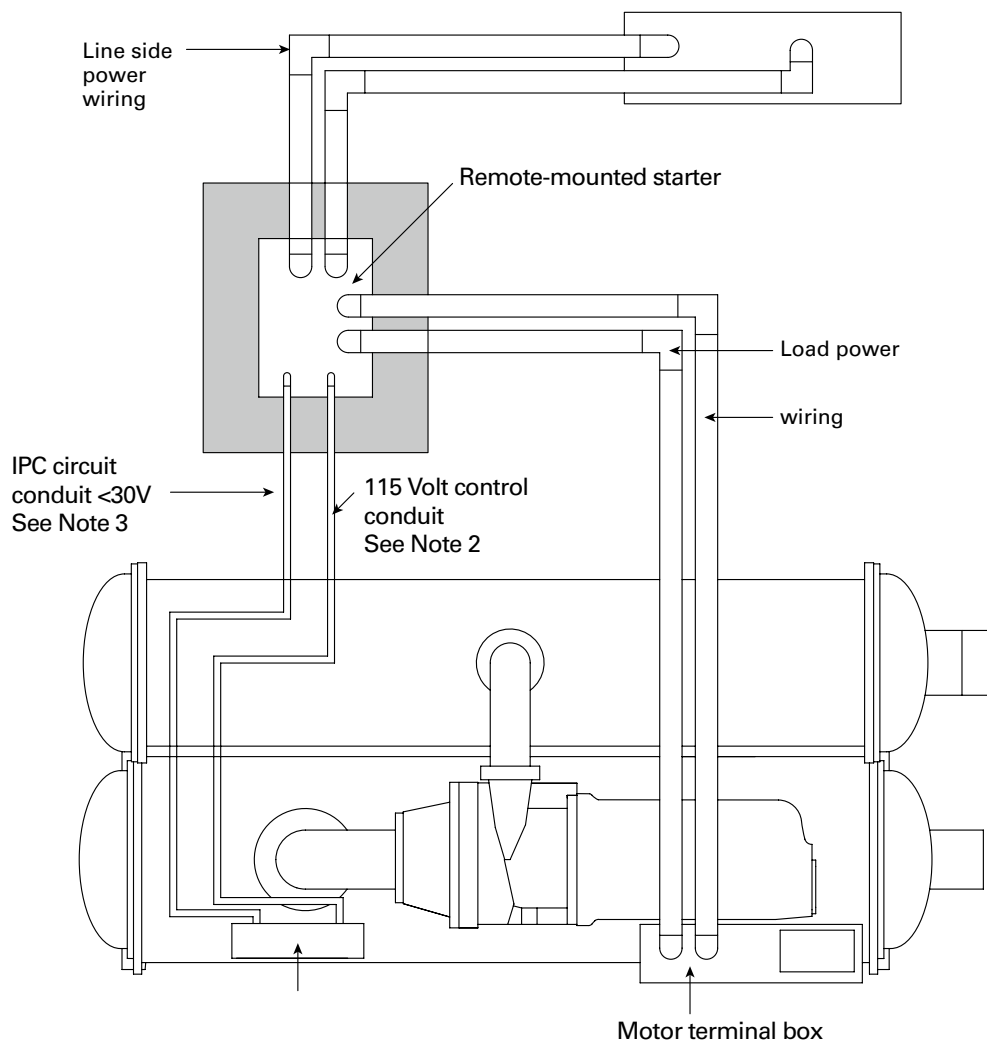

Notes:

1. Refer to the unit field connection diagram for approximate UCP knockout locations.
2. 115-volt conduit must enter the higher than 30 Vdc Class I portion of the unit control panel.
3. IPC circuit conduit must enter the Low Voltage Class II portion of the UCP.
4. See starter submittal drawing for location of incoming wiring to the starter.



Installation: Electrical

Starter to Motor (Remote- Mounted Starters Only)

Ground Wire Terminal Lugs

Ground wire lugs are provided in the motor terminal box and in the starter panel.

Terminal Clamps

Terminal clamps are supplied with the motor terminals to accommodate either bus bars or standard motor terminal wire lugs. Terminal clamps provide additional surface area to minimize the possibility of improper electrical connections.

Wire Terminal Lugs

Wire terminal lugs must be field-supplied.

1. Use field-provided crimp-type wire terminal lugs properly sized for the application.
Note: Wire size ranges for the starter line and load-side lugs are listed on the starter submittal drawings supplied by the starter manufacturer or Trane. Carefully review the submitted wire lug sizes for compatibility with the conductor sizes specified by the electrical engineer or contractor.
2. A terminal clamp with a 3/8" bolt is provided on each motor terminal stud; use the factor-supplied Belleville washers on the wire lug connections. Figure 30 illustrates the juncture between a motor terminal stud and terminal clamp.
3. Tighten each bolt to 24 footpounds.
4. Install but do not connect the power leads between the starter and compressor motor. (These connections will be completed under supervision of a qualified Trane service engineer after the prestart inspection).

CAUTION

Correct motor wire terminations!

Ensure the power supply wiring and output motor wiring are connected to the proper terminals. Failure to do so will cause catastrophic failure of the starter and, or the motor.

Bus Bars

Install bus bars between the motor terminals when a low-voltage "across-the-line," "primary reactor/resistor," "auto transformer," customer-supplied solid-state starter, or customer-supplied AFD are field applied.

Be sure to bus motor terminal T1 to T6, T2 to T4, and T3 to T5.

Note: Bus bars are not needed in high-voltage applications since only 3 terminals are used in the motor and starter.

Starter to UCP (Remote- Mounted Starters Only)

Electrical connections required between the remote-mounted starter and the unit control panel are shown in an example of a point-to-point starter-to-UCP connection diagram as shown at the end of the manual.

Note: Install control voltage conduit into control voltage section of chiller control panel and starter panel. Do not route with low voltage (30 volts) conduit wires.

When sizing and installing the electrical conductors for these circuits, follow the guidelines listed.

Unless otherwise specified use 14 ga. wire for 120 V control circuits.

CAUTION**Damage to Starter components!**

To avoid damage remove debris inside the starter panel. Failure to do so may cause an electrical short that seriously damages the starter components.

1. If the starter enclosure must be cut to provide electrical access, exercise care to prevent debris from falling inside the enclosure.
2. Use only shielded twisted pair for the interprocessor communication (IPC) circuit between the starter and the UCP on remote mounted starters. Recommended wire is Beldon Type 8760, 18 AWG for runs up to 1000 feet.

Note: The polarity of the IPC wire pair is critical for proper operation.

3. Separate low-voltage (less than 30V) wiring from the 115V wiring by running each in its own conduit.
4. As you route the IPC circuit out of the starter enclosure, make sure that it is at least 6" from all wires carrying a higher voltage.
5. For UCP IPC shielded twisted pair wiring, the shield should be grounded on one end only at UCP at 1X1-G. The other end should be unterminated and taped back on the cable sheath to prevent any contact between shield and ground.
6. Oil Pump Interlock - All starters must provide an interlock (N.O.) contact with the chiller oil pump connected to the UCP at Terminals 1A-J2-7 and 1A9-J2-9.

The purpose of this interlock is to power the oil pump on the chiller in the event that a starter failure, such as welded contacts, keeps the chiller motor running after the controller interrupts the run signal.

CAUTION**Electrical Noise!**

Maintain at least 6 inches between low-voltage (<30V) and high voltage circuits. Failure to do so could result in electrical noise that may distort the signals carried by the lowvoltage wiring, including the IPC.

Installation: Electrical

Figure 30. Terminal stud, clamp and lug assembly

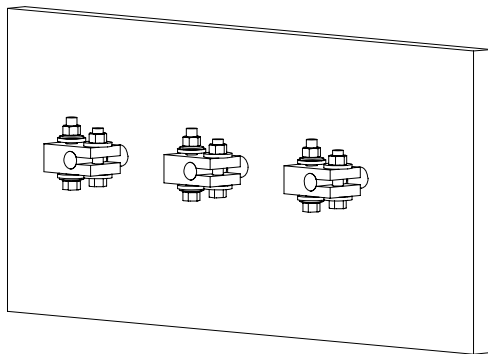
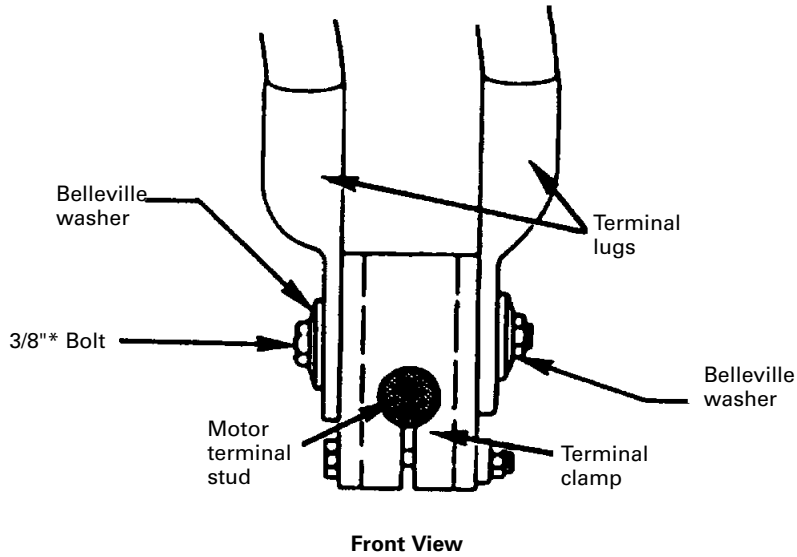

Mid Voltage
RXL RATR RPIR CXL CATR CPIR

Optional Relay Circuits

Optional Control and Output Circuits

Install various optional wiring as required by the owner's specifications.

Optional Tracer

Communication Interface

This control options allows the unit control panel to exchange information such as chiller status and operating set points with a Tracer system.

Figure 31 illustrates how such a communication control network might appear.

Note: The circuit must be run in separate conduit to prevent electrical noise interference.

Additional information about the Tracer Communication options is published in the installation manual and operator's guide that ships with the Tracer.

Unit Start-Up

All phases of initial unit start-up must be conducted under the supervision of a qualified local service engineer. This includes pressure testing, evacuation, electrical checks, refrigerant charging, actual start-up and operator instruction.

Advance notification is required to assure that initial start-up is scheduled as close to the requested date as possible.

Starter Module Configuration

The starter LLID configuration settings will be checked (and configured for Remote Starters) during start-up commissioning.

To configurate starter module, and perform other starter checks, it is recommended that the line voltage three phase power be turned off and secured (locked out), and then a separate source control power (115 Vac) be utilized to power up the control circuit. To do this, remove control coil circuit fuse, typically 2F4, and then connect separate source power cord to starter terminal block 2X1-1 (H), 2X1-2 (N), and Ground. Use the as-built starter schematic to assure correct fuse and terminals. Verify correct fuse is removed, control circuit connections are correct, then apply the 115 Vac separate source power to service the controls.

Forms Information

Samples of start-up and operating forms along with other helpful forms are found in the Operation Maintenance manual which can be obtained from the nearest Trane office.

It is recommended that the serviceman contact the local Trane office to obtain the most recent printing date of the form. The forms in the operation and maintenance manual are only current at the time of printing of the manual.

After obtaining the most recent form, complete all the information and forward it to your local Trane office.

Installation: Electrical

Figure 31-Illustrates communication control network to chiller units with Adaptview

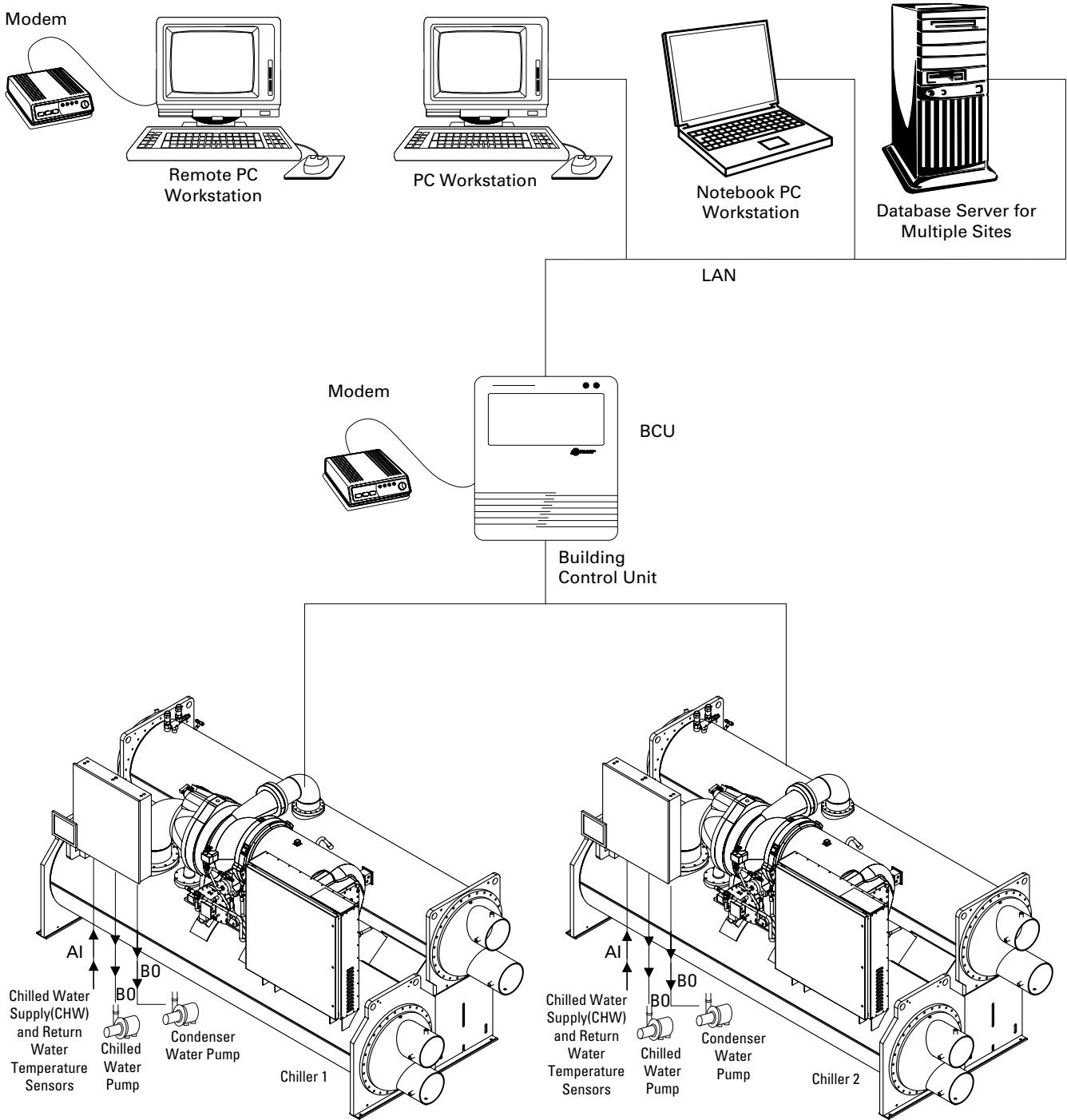

Base Loading Control Algorithm

Base Loading Control Algorithm

This feature allows an external controller to directly modulate the capacity of the chiller. It is typically used in applications where virtually infinite sources of evaporator load and condenser capacity are available and it is desirable to control the loading of the chiller. Two examples are industrial process applications and cogeneration plants. Industrial process applications might use this feature to impose a specific load on the facility's electrical system.

Cogeneration plants might use this feature to balance the system's heating, cooling and electrical generation. All chiller safeties and adaptive control functions are in full effect when Base Loading control is enabled.

If the chiller approaches full current, the evaporator temperature drops too low, or the condenser pressure rises too high, Tracer AdaptiView Adaptive.

Control logic limits the loading of the chiller to prevent the chiller from shutting down on a safety limit. These limits may prevent the chiller from reaching the load requested by the Base Loading signal.

Base Loading Control is basically a variation of the current limit algorithm. During base loading, the leaving water control algorithm provides a load command every 5 seconds. The current limit routine may limit

the loading when the current is below setpoint. When the current is within the dead-band of the setpoint the current limit algorithm holds against this loading command.

If the current exceeds the setpoint, the current limit algorithm unloads.

The "Capacity Limited By High Current" message normally displayed while the current limit routine is active is suppressed while base loading.

Base loading can occur using Tracer or an external signal.

Tracer or an external signal Base Loading: Current Setpoint Range: (20 - 100) percent RLA.

Base Loading requires Tracer Summit and an optional Tracer Communications Module (LLID)



Base Loading Control Algorithm

Tracer Base Loading

The Tracer commands the chiller to enter the base load mode by setting the base load mode request bit ON. If the chiller is not running, it will start regardless of the differential to start. While the unit is running in base loading, it will report that status back to the Tracer. When the Tracer removes the base load mode request, the unit will continue to run, using the normal chilled water control algorithm, and will turn off, only when the differential to stop has been satisfied.

External Base Base Loading

The AdaptiView accepts 2 inputs to work with external base loading.

The binary input is at 1A18 Terminals J2-1 and J2-2 (Ground) which acts as a switch closure input to enter the base loading mode. The second input, an analog input, is at 1A17 terminals J2-2 and J2-3 (Ground) which sets the external base loading setpoint, and can be controlled by either a 2-10Vdc or 4-20mA Signal. At startup the input type is configured.

The graphs in Figure 32 show the relationship between input and percent RLA. While in base loading the active current limit setpoint is set to the Tracer or external base load setpoint, providing that the base load setpoint is not equal to 0 (or out of range). If it is out of range, the front panel current limit setpoint is used. During base loading, all limits are enforced with the exception of current limit. AdaptiView™ displays the message "Unit is Running Base Loaded."

An alternative and less radical approach to Base Loading indirectly controls chiller capacity. Artificially load the chiller by setting the chilled water setpoint lower than it is capable of achieving. Then, modify the chiller's load by adjusting the current limit setpoint. This method provides greater safety and control stability in the operation of the chiller because it has the advantage of leaving the chilled water temperature control logic in effect.

The chilled water temperature control logic responds quicker to dramatic system changes, and can limit the chiller loading prior to reaching an Adaptive Control limit point.

Figure 32. Base loading with external mA input and with external voltage input

Base Loading with External mA Input

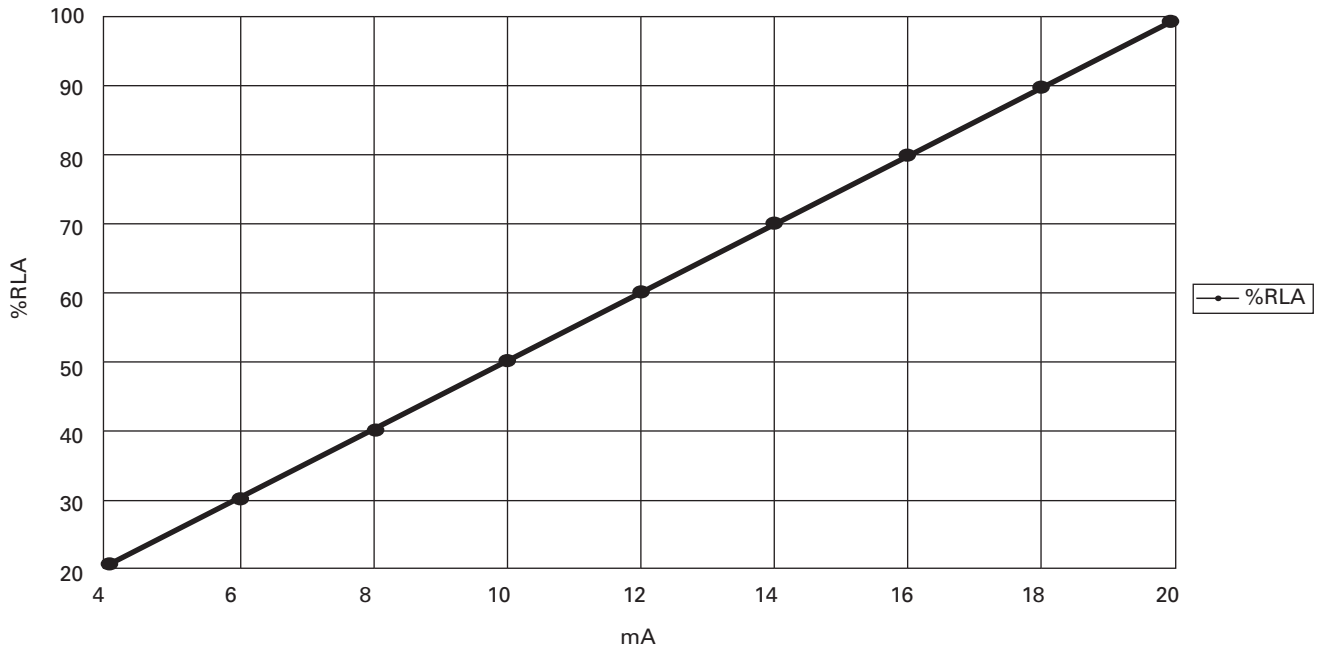

Base Loading using External Voltage Input

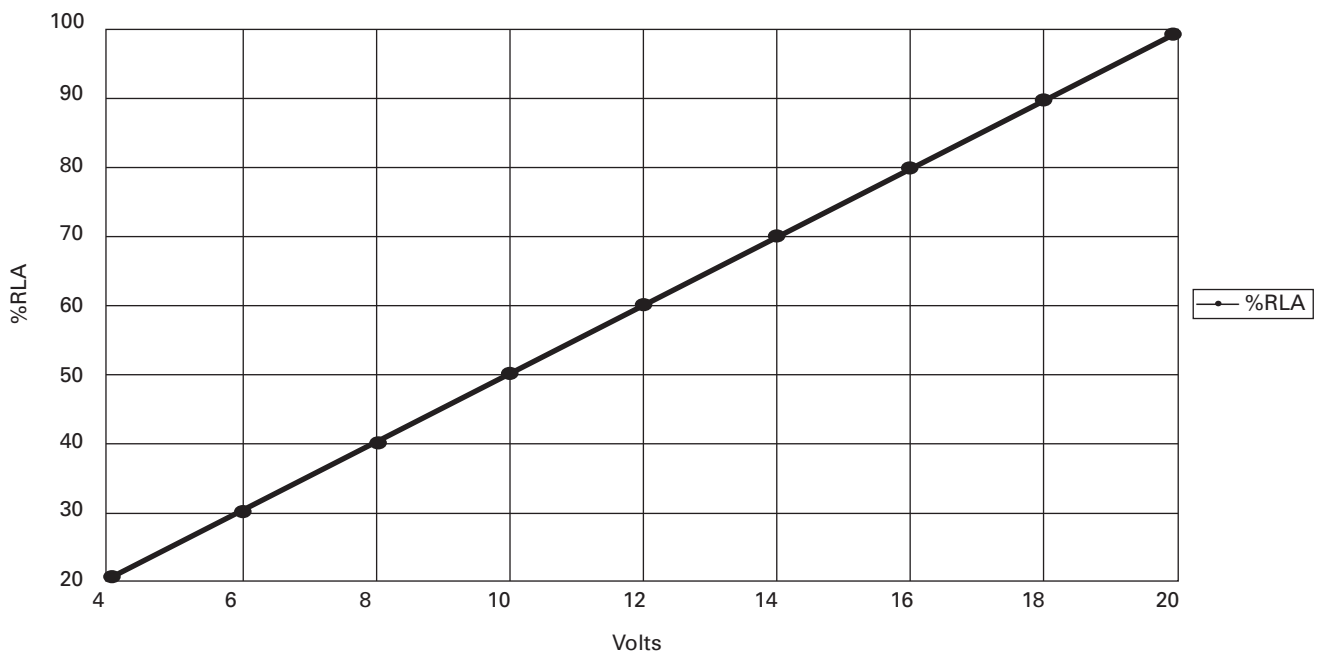

Control System Components

Control System Components

Control Panel Internally mounted devices

For visual identification Internal Control Panel mounted devices are identified by their respective schematic designation number.

Control panel items are marked on the inner back panel in the control panel (Figure 33).

The Control Panel Devices table corresponds to the same device designators. Optional controls are present when a specific optional controls package is specified. Optional controls packages are: OPST Operating Status, GBAS Generic Building Systems, EXOP Extended operation, and TRMM Tracer communications. 1A1, 1A4, 1A5, 1A6, 1A9, 1A13, 1A19, 1A26 are standard and present in all configurations. Other modules vary depending on machine optional devices.

Figure 33. Control panel components layout

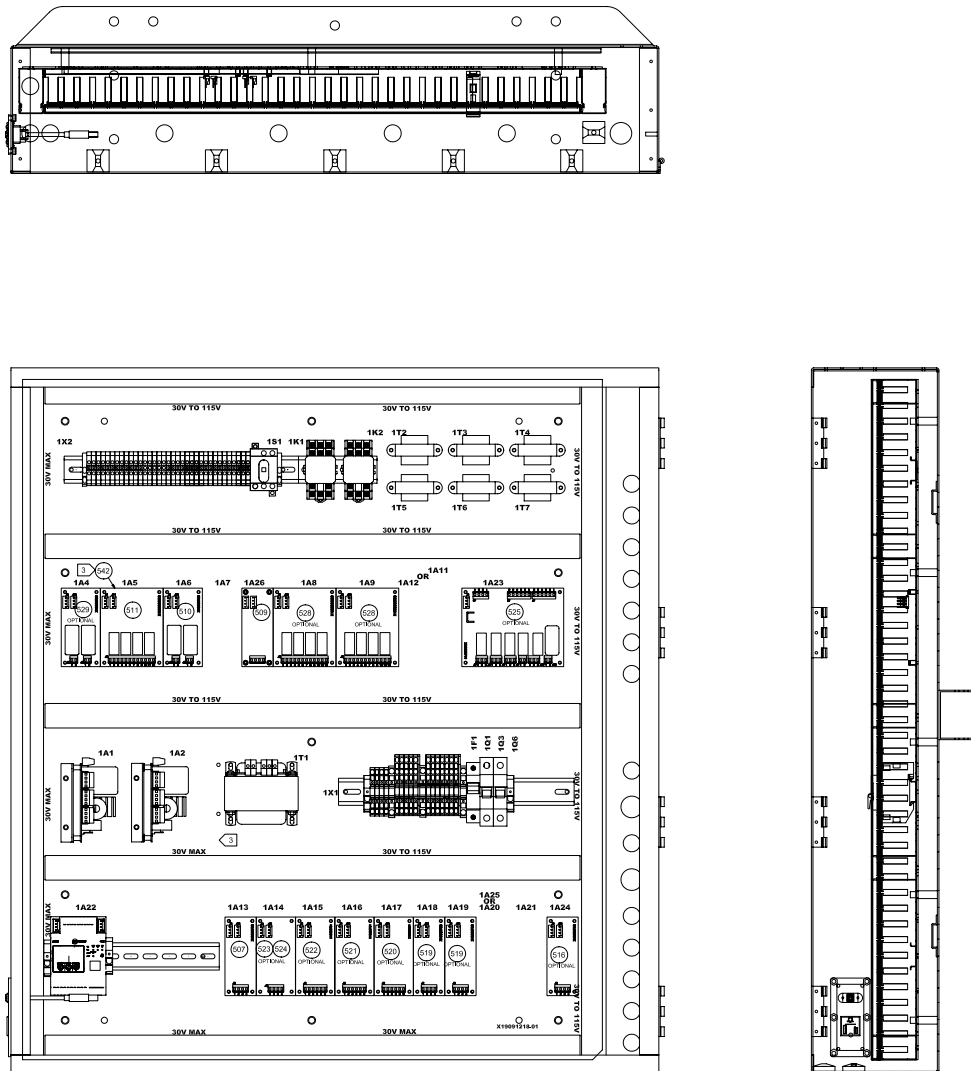

Chilled and Condenser Water Flow Interlock Circuits

Proof of chilled water flow for the evaporator is made by the closure of flow switch 5S1 and the closure of auxiliary contacts 5K1 on terminals 1X1-5 and 1A6- J3-1 and J3-2. Proof of condenser water flow for the condenser is made by the closure of flow switch 5S2 and the closure of auxiliary contacts 5K2 on terminals 1X1-6 and 1A6-J2-1 and J2-2.

Head Relief Request Output

When the chiller is running in Condenser Limit Mode or in Surge Mode, the head relief request relay on the 1A9-J2-6 to J2-4 will be energized and can be used to control or signal for a reduction in the entering condenser water temperature.

This is designed to prevent high refrigerant pressure trip-outs during critical periods of chiller operation.

Maximum Capacity Relay

When the chiller has been operating at maximum capacity for over a 10 minute (UT™ adjustable) time period this relay will activate. Also upon being less than maximum capacity for 10 minutes, this relay will deactivate. This is located at LLID 1A9-J2-1 and J2-3.

Compressor Running Relay

Relay activates while the compressor is running.



Control System Components

Control Panel Devices

Standard Devices

Description	Controls Package		Purpose	Field Connection Point Terminals
1A1 Power Supply	Standard	#1	Converts 24 vac to 24 Vdc	not for field use
1A4 Quad High Voltage Input	Standard		High Pressure Cutout	not for field use
1A5 Quad Relay Output modules	Standard	Relay #1	Chilled water pump (Relay #1)	J2-1 NO, J2-2 NC, J2-3 common
1A5 Quad Relay Output modules	Standard	Relay #2	Condenser water pump control (Relay #2)	J2-4 NO, J2-5 NC, J2-6 common
1A6 Dual High Voltage Input	Standard	Input 1	Condenser Flow Input	J3-2 Condenser water flow switch
1A6 Dual High Voltage Input	Standard	Input 2	Evaporator Flow Input	J2-2 Chilled water flow switch
1A9 Standard Quad Relay Output Status	Standard	Relay #1	Maximum Capacity Relay	J2-1 NO, J2-2 NC, J2-3 common
1A9 Standard Quad Relay Output Status	Standard	Relay #2	Head Relief Request Relay	J2-4 NO, J2-5 NC, J2-6 common
1A9 Standard Quad Relay Output Status	Standard	Relay #3	Oil Pump	J2-7 NO, J2-8 NC, J2-9 common
1A19 Standard Dual LV Binary input module	Standard	Signal #1	Oil Differential Pressure Switch	J2-3 Binary Input Signal #1, J2-4 Ground
1A13 Dual LV Binary input module	Standard	Signal #1	External Auto Stop,	J2-1 Binary Input Signal #1, J2-2 Ground
1A13 Dual LV Binary input module	Standard	Signal #2	Emergency stop	J2-3 Binary Input Signal #2, J2-4 Ground
1F1	Standard		LLID Power Supply Transformer Primary Circuit protection	not for field use
1F2	Standard		Oil Pump Motor Branch Circuit protection	not for field use
1T1	Standard		Control Panel Power Transformer ; 120:24Vac	not for field use
1Q1	Standard		Circuit Breaker Compressor Motor Controller Control Power Branch Circuit	not for field use
1Q3	Standard		Circuit Breaker – Module [-LLID] Power Supply Branch Circuit	not for field use
1X1 Terminal Block	Standard		Control Panel Terminal Block, Flow switch connections	1X1-5 Chilled water flow switch input 1X1-6 Condenser water flow switch input

Control System Components

OPST Operation Status Option

Relay output module 1A8 provide relay outs as shown:

1A8 Optional Quad Relay Output Status	OPST	Relay #1	MAR Alarm Relay, (Non-Latching)	J2-1 NO, J2-2 NC, J2-3 common
1A8 Optional Quad Relay Output Status	OPST	Relay #2	Limit Warning Relay,	J2-4 NO, J2-5 NC, J2-6 common
1A8 Optional Quad Relay Output Status	OPST	Relay #3	MMR Alarm Relay (Latching)	J2-7 NO, J2-8 NC, J2-9 common
1A8 Optional Quad Relay Output Status	OPST	Relay #4	Compressor running relay	J2-10 NO, J2-11 NC, J2-12 common

EXOP Extended Operation Option

The following modules (1A17, 1A18) are provide when this control package is specified.

1A17 Optional Dual Analog Input/Output Module	EXOP	Signal #1	External Base Loading Setpoint input	J2-2 Input #1, J2-3 Ground
1A17 Optional Dual Analog Input/Output Module	EXOP	Signal #2	Refrigerant monitor inputs	J2-5 Input #2, J2-6 Ground
1A18 Optional Dual LV Binary input module	EXOP	Signal #1	External Base Loading Enable or Disable input, points	J2-1 Binary Input Signal #1, J2-2 Ground
1A18 Optional Dual LV Binary input module	EXOP	Signal #2	External Hot Water Control Enable or Disable input	J2-3 Binary Input Signal #2, J2-4 Ground

Refrigerant Monitor Input 1A17

Analog type input 4-20ma input signal to the 1A17 J2-5 to J2-6 (ground). This represents 0-100 ppm.

TRMM TRM4 TRM5 (Tracer Comm 4, Comm 5 interface)

1A14 Optional Communication Interface Module	TRM4 / TRM5	Tracer Communications	J2-1 COMM+, J2-2 COMM -J2-3, COMM +J2-4, COMM -,
--	-------------	-----------------------	--

CDRP (Condenser Refrigerant Pressure Output) (1A15)

1A15 Optional Dual Analog Input/output Module	CDRP	Signal #2	Condenser Refrigerant Pressure output	J2-4 Output #2, J2-6 Ground
1A15 Optional Dual Analog Input/output Module	CDRP	Signal #1	Percent RLA Compressor Output	J2-1 Output #1, J2-3 Ground

CDRP Refrigerant Pressure Output Option 1A15:

Refrigerant Pressure Output can be configured at commissioning to correspond to either A) the absolute condenser pressure, or B) the differential pressure of the evaporator to condenser pressures.

This output is located at 1A15-J2-4(+) to J2-6 (ground)

The Output can source a maximum of 22 mA of current.

A) Condenser Pressure Output.

2 to 10 Vdc corresponds to 0 Psia to the HPC (in Psia) setting.

Temperature based

On standard machines the Percent Condenser Pressure Indication Output is based on the Saturated Condenser Refrigerant and a temperature to pressure conversion is made.

If the Condenser Saturated Temperature goes out of range due to an open or short, a pressure sensor diagnostic will be called and the output will also go to the respective out of range value. That is, for an out of range low on the sensor, the output will be limited to 2.0 Vdc. For an out of range high on the sensor, the output will be limited to 10.0 Vdc.

Figure 34.

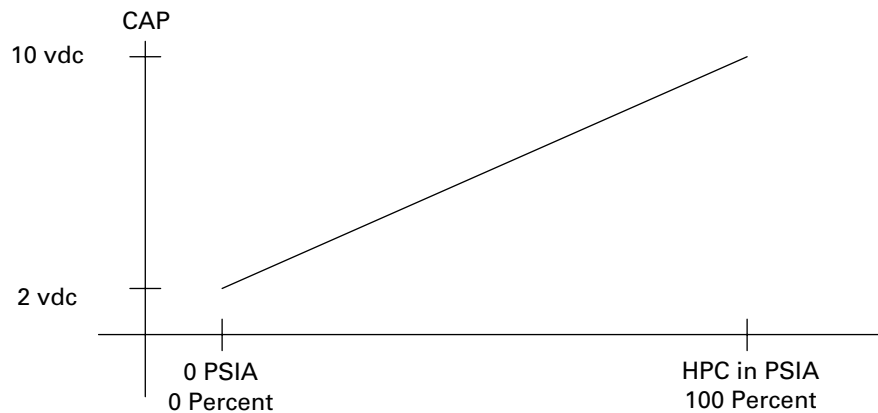

B) Refrigerant Differential Pressure Indication Output:

A 2 to 10 Vdc analog output is provided instead of the previous condenser pressure output signal. This 2 signal corresponds to a predetermined minimum and maximum pressure settings setup at commissioning of this feature. This relationship can be altered using TracerTU™ if required.

The “Minimum Delta Pressure “is typically set to 0 psi and will then correspond to 2 Vdc. The “Maximum Delta Pressure “ is typically set to 30 psi and corresponds to 10 Vdc.

The Minimum Delta Pressure Calibration setting has a range of 0-400 psid (0-2758 kPa) in increments of 1 psid (1kPa). The Maximum Delta Pressure Calibration setting has a range of 1-400 psid (7-2758 kPa) in increments of 1 psid (1kPa). The condenser refrigerant pressure is based on the Condenser Refrigerant Temperature sensor. The evaporator refrigerant pressure is based on the Saturated Evaporator Refrigerant Temperature Sensor.

Figure 35. Delta pressure setting

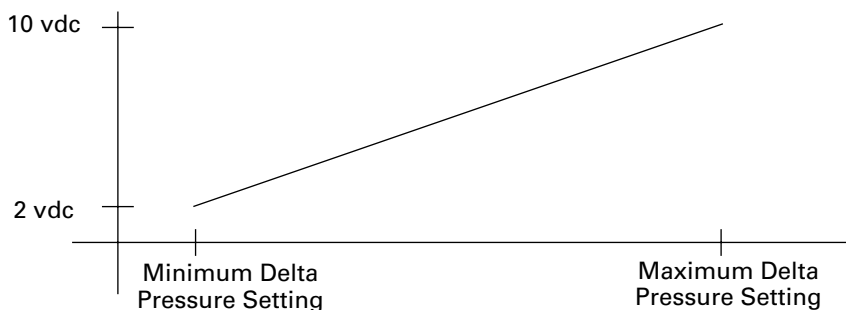

Control System Components

GBAS (Generic Building Automation System)

1A15 Optional Dual Analog Input/output Module	GBAS	Signal #1	Percent RLA Compressor Output	J2-1 Output #1, J2-3 Ground
1A15 Optional Dual Analog Input/output Module	GBAS	Signal #2	Condenser Refrigerant Pressure or Evaporator/Condenser differential	J2-4 Input #2, J2-6 Ground
1A16 Optional Dual Analog Input/output Module	GBAS	Signal #1	Chilled Water Reset input, or External Chiller Water Setpoint	J2-2 Input #1, J2-3 Ground
1A16 Optional Dual Analog Input/output Module	GBAS	Signal #2	External Current limit Setpoint	J2-5 Input #2, J2-6 Ground

Percent RLA Output

2 to 10 Vdc corresponding to 0 to 120% RLA. With a resolution of 0.146%. The Percent RLA Output is polarity sensitive.

The following graph illustrates the output:

Figure 36. Voltage versus percent RLA

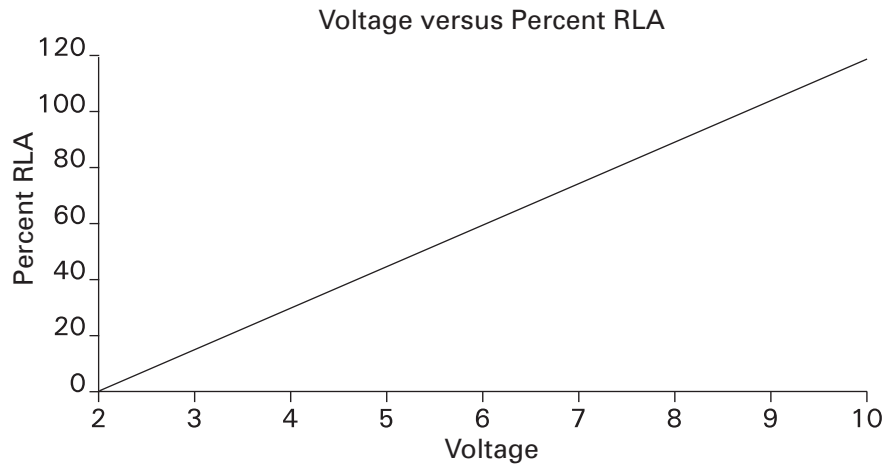

External Chilled Water Setpoint (ECWS)

The External Chilled Water Setpoint allows the chilled water setpoint to be changed from a remote location. The External Chilled Water Setpoint is found on 1A16 J2-2 to J2-3 (ground). 2-10 Vdc and 4-20 mA correspond to a 0 to 65°F (-17.8 to 18.3°C) CWS range.

External Current Limit Setpoint

The External Current Limit is an option that allows the current limit setpoint to be changed from a remote location. The External Limit Setpoint is found on 1A16 J2-5 to J2-6 (ground), 2-10 Vdc and 4-20 mA each correspond to a 40 to 120 percent RLA range. AdaptiView limits the maximum ECLS to 100 percent.

Module Characteristics

1A1, 1A2, Power Supply :

Unit Control Power Supply Module Converts 27 Vac to 24 Vdc.

Power Input Voltage: 23VRMS minimum, 27VRMS Nominal, 30VRMS maximum

Frequency: 50-60 Hz

Current: Full load 27 Vac – 4.30 A (RMS)

Inrush 27 Vac (RMS) ~ 30A (RMS)

Power Output: Class II Voltage 24 Vdc, Rated Current 2.44 Amps.

1A4, 1A6, Dual high Voltage Binary input module:

Binary Input Signal #1 J2-1 to 2 Binary Input Signal #2 J3-1 to 2 High Voltage Binary Input: Off

Voltage: 0 to 40 Vac RMS , On

Voltage: 70 to 276 Vac RMS

Input is not polarity sensitive (Hot and neutral can be switched), Input impedance 130K to 280K ohms

14-26 AWG with a maximum of two 14 AWG

Power, 24 +/- 10 percent Vdc, 20 mA maximum. Trane IPC3 protocol. J1-1 +24Vdc, J1-2 Ground, J1-3 COMM +, J1-4 COMM-

1A5, 1A8, 1A9 Quad Relay Output Status:

Relay #1 J2-1 NO, J2-2 NC, J2-3 common

Relay #2 J2-4 NO, J2-5 NC, J2-6 common

Relay #3 J2-7 NO, J2-8 NC, J2-9 common

Relay #4 J2-10 NO, J2-11 NC, J2-12 common

Relay Outputs: at 120 Vac: 7.2 Amps resistive, 2.88 Amps pilot duty, 1/3 HP, 7.2 FLA, at 240 Vac: 5 Amps general purpose 14-26 AWG, two 14 AWG Maximum Power, 24 ±10 percent Vdc, 100 mA maximum. Trane IPC3 protocol.

1A13, 1A18, 1A19, 1A24 Dual Binary input module:

J2-1 Binary Input Signal #1, J2-2 Ground, J2-3 Binary Input Signal #2, J2-4 Ground Binary Input: Looks for a dry contact closure. Low Voltage 24V 12 mA.

14 - 26 AWG with a maximum of two 14 AWG Power, 24 +/- 10 percent Vdc, 40 mA maximum Trane IPC3 protocol.

1A14 Communication interface Module Power, 24 ± 10 percent Vdc, 50 mA maximum. Trane IPC3 protocol.

Control System Components

1A14 Communication Polarity

J1-1	+24 Vdc	J2-1 COMM +.	J11-1+24 Vdc
J1-2	Ground	J2-2 COMM -	J11-2 Ground
J1-3	COMM +	J2-3 COMM +	J11-3 COMM +
J1-4	COMM -	J2-4 COMM -	J11-4 COMM

1A15, 1A16, 1A17, Dual Analog Input/output Module;

Analog Output: The Analog Output is a voltage only signal. 2-10 Vdc at 22mA

J2: 14 - 26 AWG with a maximum of two 14 AWG

J2-1 Output #1 to J2-3 (ground),

J2-4 Output #2 to J2-6 (ground).

AdaptiView provides a 2-10 Vdc analog signals as Outputs. The Output's maximum source capability is 22mA. The maximum recommended length to run this signal is included in the table below.

Analog Input:

The analog input can be software switched between a voltage input or a current input. When used as a current input a 200 Ohm load resistor is switched in.

0-12 Vdc or 0-24 mA Analog Inputs

AdaptiView accepts either a 2-10 Vdc or 4-20 analog input suitable for customer external control. The type is determined at unit commissioning during feature installation.

J2: 14-26 AWG with a maximum of two 14 AWG

J2-2 Input #1 to J2-3 (ground).

J2-5 Input #2 to J2-6 (ground).

Power, 24 +/- 10 percent Vdc, 60 mA maximum, Trane IPC3 protocol.

Maximum Length to Run external Output signals

Gauge	Ohms per Foot	Length (Feet)	Length (Meters)
14	0.00 2823	1062.7	324
16	0.004489	668.3	203.8
18	0.007138	420.3	128.1
20	0.01135	264.3	80.6
22	0.01805	166.3	50.7
24	0.0287	104.5	31.9
26	0.04563	65.7	20
28	0.07255	41.4	12.6

Note: the above table is for copper conductors only.

Note: If the chiller is operating in a limit mode (current limit, condenser limit, evaporator limit, and so forth), the limit operation has priority over all Large display™ manual modes of operation.

On each AdaptiView power-up, the inlet guide vanes are driven full closed to recalibrate the zero position (steps) of the Stepper motor vane actuator.

Motor Temperature Sensor Module

The motor temperature module 1A26 connects using unit wiring to the three motor winding temperature sensors. This module is located in the control panel where the module is connected to the IPC bus.

Temperature Sensors

Evaporator entering 4R6 Evaporator leaving 4R7 Condenser entering 4R8 Condenser leaving 4R9 Oil temperature 4R5 Outdoor air 4R13 Evaporator saturated refrigerant 4R10 Condenser saturated refrigerant 4R11

Probe Operating Temperature Range -40 to 121°C

Accuracy ± 0.250°C over the range - 20 to 50°C ± 0.50°C over the range -40 to 121°C

Starter Module

In the hierarchy of modules the Starter module 2A1 (1A23 when customer-supplied starter specified) is second only to the Large display™.

The starter module is present in all starter selections. This includes Wye Delta, Across the Line, and Solid State whether remote unit mounted or supplied by others. The starter module provides the logic to provide the motor protection for current overload, phase reversal, phase loss, phase imbalance, and momentary power loss.

Electrical Sequence

This section will acquaint the operator with the control logic governing chillers equipped with Tracer AdaptiView control systems.

Note: The typical wiring diagrams are representative of standard units and are provided only for general reference. They may not reflect the actual wiring of your unit. For specific electrical schematic and connection information, always refer to the wiring diagrams that shipped with the chiller.

With the supply power disconnect switch or circuit breaker (2Q1 or 2K3) on, 115-volt control power transformer 2T5 and a 15-amp starter panel fuse (2F4) to terminal (2X1-1) starter panel to terminal 1X1-1 in the control panel. From this point, control voltage flows to:

1. Circuit Breaker 1Q1 which provides power to the starter module (2A1) relay outputs and the High Pressure Cutout switch (4S1).
2. Circuit Breaker 1Q3 which provides power to Transformer (1T1) which steps down the 115 Vac to 24 Vac. This 24 Vac then powers the 24 Vdc power supply 1A1, and 1A2 if present. The 24 Vdc is then connected to all modules using the IPC Bus providing module power. 1Q3 also provides power to the external chiller water proof of flow device connected between terminal block 1X1-5 to 1A6-J3-2, and condenser water proof of flow device connected at 1X1-6 to 1A6-J2-2.

Control System Components

3. The Large display™ display module 1A22, receives 24 Vdc power from the IPC bus.

AdaptiView and Wye-Delta Starter Control Circuits (Sequence of Operation)

Logic Circuits within the various modules will determine the starting, running, and stopping operation of the chiller. When operation of the chiller is required the chiller mode is set at "Auto." Using customer-supplied power, the chilled water pump relay (5K1) is energized by the 1A5 Module output at 1A5-J2-4, and chilled water flow must be verified within 4 minutes 15 seconds by the 1A6 module. The main processors logic decides to start the chiller based on the differential to start setpoint. With the differential to start criteria met module 1A5 then energizes the condenser water pump relay (5K2) using customer-supplied power at 1A5 J2-1.

Based on the restart inhibit function and the differential to start setpoint, oil pump (4M3) will be energized by 1A9 module (1A9-J2-7). The oil pressure switch must be closed for 30 continuous seconds and condenser water flow verified within 4 minutes 15 seconds for the compressor start sequence to be initiated.

When less than 5 seconds remain before compressor start, a starter test is conducted to verify contactor state prior to starting the compressor. The following test or start sequence is conducted for "Wye-Delta" starters:

1. Test for transition complete contact open (1A23X or 2A1-J12-2) –160 to 240 msec. An MMR diagnostic will be generated if the contact is closed.
2. Delay time - 20 msec.
3. Close start contactor (2K1) and check for no current - 500 msec. If currents are detected, the MMR diagnostic "Starter Fault Type I" is generated and closes for one second.
4. Delay time - 200 msec. (Opens 2K1).
5. Close shorting contactor, (2K3) and check for no current (1A23 or 2A1 J4-1) for one second. If currents are detected the MMR diagnostic "Starter Fault Type II" is generated. (Starter Integrity test)
6. If no diagnostics are generated in the above tests, the stop relay (2A1- J10) is closed for two seconds and the start relay (2A1-J8) is closed to energize the start contactor (2K1). The shorting contactor (2K3) has already been energized from (F) above. The compressor motor (4M1) starts in the "Wye" configuration, an auxiliary contact (2K1-AUX) locks in the start contactor (2K1) coil.
7. After the compressor motor has accelerated and the maximum phase current has dropped below 85 percent of the chiller nameplate RLA for 1.5 seconds, the starter transition to the "Delta" configuration is initiated.
8. The transition contactor (2K4) is closed through relay 2A1-J2, placing the transition resistors (2R1, 2R2, and 2R3) in parallel with the compressor motor windings.
9. The shorting contactor (2K3) is opened through the opening of relay 2A1-J4 100 msec after the closure of the transition relay 2A1-J2.
10. The run contactor (2K2) is closed through relay 2A1-J6, shorting out the transition resistors 260 milliseconds after the opening of the shorting relay 2A1-J4. This places the compressor motor in the "Delta" configuration and the starter module waits to look for this transition for 2.35 seconds through the closure of the transition complete contacts 2K2- AUX at module 2A1-J12 input.

11. The starter module must now confirm closure of the transition complete contact (2K2- AUX) within 2.32 to 2.38 seconds after the run relay (2A1-J6) is closed. Finally, the transition relay (2A1-J2) is opened de-energizing the transition contactor (2K4) and the compressor motor starting sequence is complete.

An MMR diagnostic will be generated if the transition complete contacts (2K2-AUX) do not close.

Now that the compressor motor (4M1) is running in the "Delta" configuration, the inlet guide vanes will modulate, opening and closing to the chiller load variation by operation of the stepper vane motor actuator (4M2) to satisfy chilled water setpoint. The chiller continues to run in its appropriate mode of operation: Normal, Softload, Limit Mode, and so forth. If the chilled water temperature drops below the chilled water set point by an amount set as the "differential to stop" setpoint, a normal chiller stop sequence is initiated as follows:

1. The inlet guide vanes are driven closed for 50 seconds.
2. After the 50 seconds has elapsed, the stop relay (2A1-J10) and the condenser water pump relays (1A5-J2) open to turn off. The oil pump motor (4B3) will continue to run for 1 minute post-lube while the compressor coasts to a stop. The chilled water pump will continue to run while the Main processor module (1A22) monitors leaving chilled water temperature preparing for the next compressor motor start based on the "differential to start" setpoint.

If the <STOP> key is pressed on the operator interface, the chiller will follow the same stop sequence as above except the chilled water pump relay (1A5-J2) will also open and stop the chilled water pump after the chilled water pump delay timer has timed out after compressor shut down.

If the "Immediate Stop" is initiated, a panic stop occurs which follows the same stop sequence as pressing the <STOP> key once except the inlet guide vanes are not sequence closed and the compressor motor is immediately turned off.



Machine Protection and Adaptive Control

Machine Protection and Adaptive Control

Momentary Power Loss (MPL) Protection

Momentary power loss detects the existence of a power loss to the compressor motor and responds by initiating the disconnection of the compressor motor from the power source.

Power interruptions of less than 30 line-cycles are defined as momentary power losses. Tests have shown that these short-term power interruptions can be damaging to the motor and compressor if the chiller is reconnected to the line while the motor and line phases do not match. The chiller will be shut down when a MPL is detected and will display a non-latching diagnostic indicating the failure.

The oil pump will be run for the post-lube time period when power returns. The compressor and compressor motor are protected from damage from large torques and in-rush currents resulting from reconnecting the compressor motor to the power source following a momentary loss of power.

MPLs greater than 2 or 3 cycles are detected resulting in unit shut down. Disconnection from the line is initiated within 6 line-cycles of the power loss. MPL protection is active anytime the compressor is in the running mode. (The transition complete input has been satisfied.)

Note: MPL is defaulted to enabled however can be disabled, if required using UT™.

Figure 37. CVGF sequence of operation: momentary power loss, (Lagre display™ and starter module remain pow

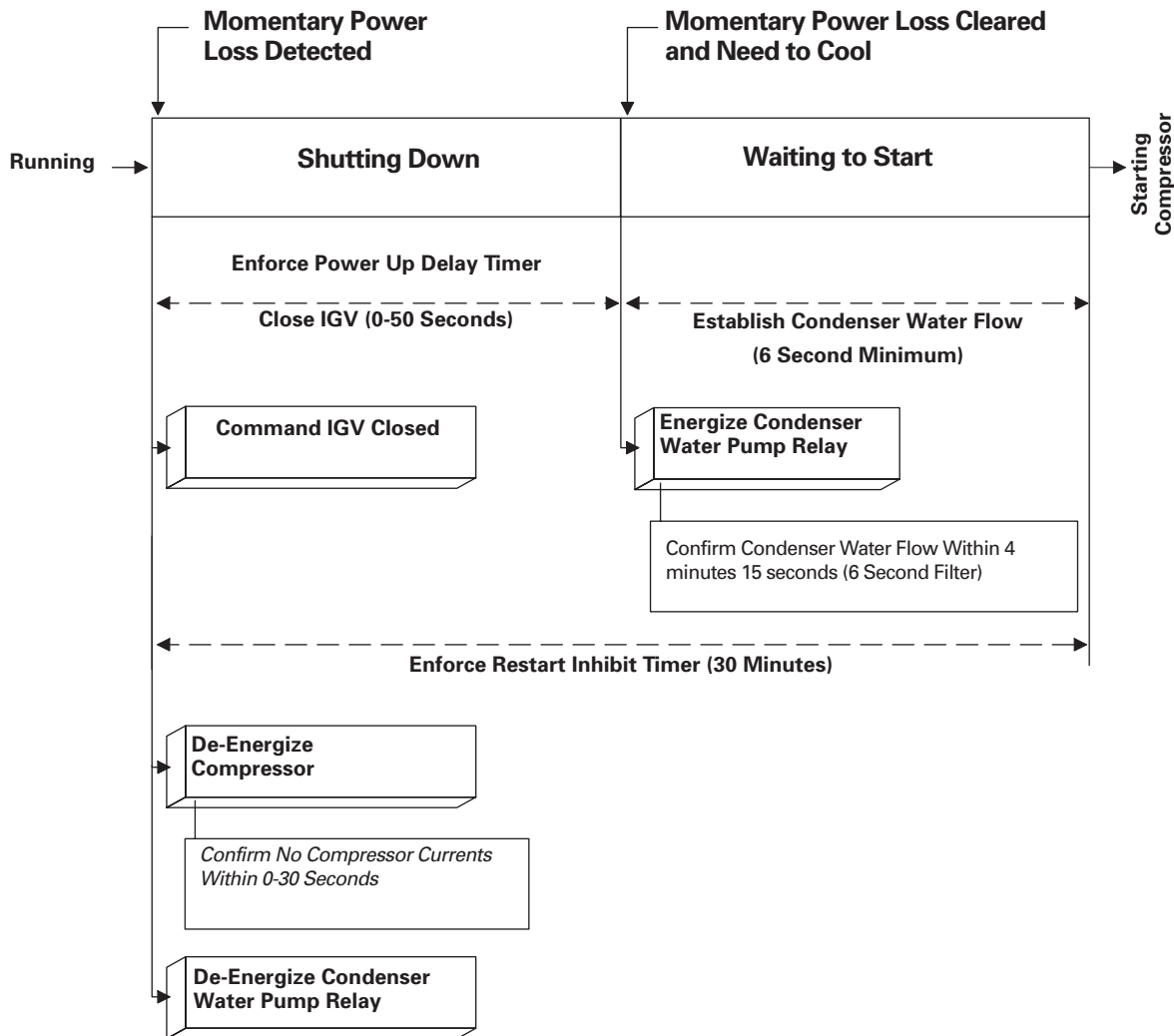

Current Overload Protection

Motor currents are continuously monitored for over current protection and locked rotor protection. This protects the chiller from damage due to current overload during starting and running modes but is allowed to reach full load amps. This overload protection logic is independent of the current limit. The overload protection will ultimately shut the unit down anytime the highest of the three phase currents exceeds the time trip curve. A manual reset diagnostic describing the failure will be displayed.

Overload protection for the motor starts based on the maximum time to transition permitted for a particular motor.

Running Overload Protection

In the run mode, a time trip curve is looked at to determine if a diagnostic should be called. The starter LLID continuously monitors compressor line currents to provide running overload and locked rotor protection.

Overload protection is based on the line with the highest current. It triggers a manually resettable diagnostic shutting down the compressor when the current exceeds the specified time trip curve. The compressor overload time trip curve is expressed as a percent of the RLA of the compressor and is not adjustable: Overload Must Hold = 102 Percent RLA.

Overload Must Trip in 20 (+0 -3) seconds = 112 Percent RLA

(Note the above gives a nominal 20 seconds must trip point of 107 Percent RLA.)

Overload Must Trip in 1.5 seconds = 140 Percent RLA (Nominal)

The time trip curve is as follows:

Figure 38. Overload time trip versus percent RLA

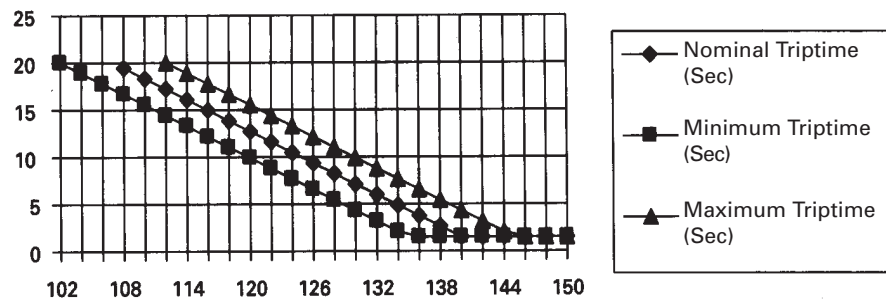

Current Limit Protection

Current Limit Protections exist to avoid motor current overload and damage to the compressor motor during starting and running.

The Current Limit Setpoint (CLS) can be changed from: Front Panel, External Analog input (with GBAS option), or Tracer (Tracer option). Tracer current setpoint has the highest priority, unless disabled in the Large display™ Setpoint source override menu. The External CLS has second priority, and will be used if Tracer is disabled or not installed. The Front Panel Setpoint has the lowest priority, and will be used if Tracer and the External CLS are both disabled.

Compressor motor current is continuously monitored and current is controlled using a limit function to prevent running into overload diagnostic trips. The current limit control logic attempts to prevent the motor from shutting down on a diagnostic trip by limiting compressor current draw relative to an adjustable current limit Large display™ CLS.

This setpoint can also be lowered to provide electrical demand limiting on the unit as required. This could also be set to allow the chiller to continue to run at a lower load to avoid tripping off using a diagnostic.

The Current Limit function uses a PID algorithm (similar to the Leaving Water Temperature control) that allows the chiller to run at the CLS. At machine startup, or with any setpoint change the new current limit setpoint reached after the filtered setpoint time elapses. The minimum current limit setpoint is default set to 40 percent RLA (20-100 percent). The filtering time default is set to 10 minutes (0-120 minutes); however these can be altered using the UT™. This filtered setpoint allows for stable control if the Current Limit setpoint is adjusted during a run.

Phase Loss Protection

Loss of phase detection protects the chiller motor from damage due to a single-phasing condition. The controls will shut down the chiller if any of the three phase currents feeding the motor are lost. The shutdown will result in a latching diagnostic indicating the failure.

Reverse Rotation Protection

This function protects the compressor from damage caused by being driven in the reverse direction. Incorrect phase rotation detection results in a manually resettable diagnostic. Phase Reversal protection default is set to enable, however can be disabled using UT™.

Differential to Start or Stop

The Differential to Start setpoint is adjustable from 1 to 10°F (0.55 to 5.5°C) and the Differential to Stop setpoint adjustable from 1 to 10°F (0.55 to 5.5°C). Both setpoints are with respect to the Active Chilled Water Setpoint. When the chiller is running and the Leaving Water Temperature (LWT) reaches the Differential to Stop setpoint the chiller will go through its shutdown sequence to Auto. Reference Figure 11.

SoftLoading

Softloading stabilizes the startup control during the initial chiller pulldown. Soft loading is used to bring the building loop temperature from its start value to the Chilled Water or Hot Water Setpoint in a controlled manner. Without soft loading, the chiller controls will load the chiller rapidly and use the full chiller capacity to bring the loop temperature to setpoint. Although the start temperature of loop may have been high, the actual system load may be low. Thus, when the setpoint is met the chiller must unload quickly to the system load value. If it is not able to unload quickly enough, the supply water temperature will drop below setpoint and may even cause the chiller to cycle off. Soft loading prevents the chiller from going to full capacity during the pull-down period. After the compressor has been started, the starting point of the filtered setpoint is initialized to the value of the Evaporator Leaving Water temperature and the percent RLA.

There are three independent Softload setpoints:

- Capacity Control Softload Time default is to 10 minutes and settable from 0-120 minutes. This setting controls the time constant of the Filtered Chilled Water Setpoint.
- Current Limit Control Softload Time default is 10 minutes and settable from 0-120 minutes. This setting controls the time constant of the Filtered Current Limit Setpoint.
- Current Limit Softload Starting Percent default is 40 percent RLA and settable from 20-100 percent. This setting controls the Starting point of the Filtered Current Limit Setpoint.

Note: UT™ provides access to these three setpoints.

Minimum and Maximum Capacity Limit

A Minimum Capacity can be set to limit the unloading ability of the compressor forcing differential stop to be reached cycling the chillers. Minimum capacity limit will be displayed when in this limit mode. This indicates when the chiller is running fully unloaded. Similarly a maximum capacity can be set to limit normal chilled water temperature control. The maximum capacity relay is energized which is a signal used by generic BAS systems to start another chiller.

The minimum (default at 0 percent) and maximum (default at 100 percent) capacity are adjustable using UT™.

Evaporator Limit

Evaporator refrigerant temperature is continuously monitored to provide a limit function that prevents low refrigerant temperature trips. This allows the chiller to continue to run at a reduced load instead of tripping off at the Low Refrigerant Temperature Cut-out Setpoint (LRTC).

Evaporator limit could occur with an initial pulldown of a loop temperature where the condenser is colder than the evaporator (inverted start), and the evaporator refrigerant temperature may drop below the LRTC. This limit prevents the unit from shutting down on a diagnostic during this type of pulldown. Another example is a chiller that is low on refrigerant charge. It will run with low evaporator refrigerant temperatures.

This limit allows the chiller to continue to run at a reduced load.

Evaporator Limit uses the Evaporator Refrigerant Temperature sensor in a PID algorithm (similar to the Leaving Water Temperature control) that allows the chiller to run at the LRTC + 2 degree F (1.1°C).

When actively limiting machine control “Evaporator Temperature Limit” will be displayed as a suboperating mode.

Leaving Water Temperature Cut-out

Leaving water temperature cutout is a safety control that protects the chiller from damage caused by water freezing in the evaporator. The cutout setpoint is factory set at 36°F (2.2°C) however is adjustable with UT™. The cut-out strategy is illustrated in Figure 39.

The Leaving Water Temperature Cut-out Setpoint is independently adjustable from the chilled water setpoint. Shutdown of the compressor due to violation of the Leaving Water Temperature Cut-out results in an automatically resettable diagnostic (MAR). The Large display™ Operating Mode indicates when the Leaving Water Temperature Cut-out Setpoint conflicts with the chilled water temperature setpoint by a message on the display. The Leaving Water Temperature Cutout Setpoint and chilled water setpoint, both active and front panel, are separated by a minimum of 1.7°F (0.94°C). (See Cut-out Strategy Figure 39.) When either difference is violated, the AdaptiView does not permit the above differences to be violated and the display exhibits a message to that effect and remains at the last valid setpoint. After violation of the Leaving Water Temperature Cut-out Setpoint for 30°F (16.7°C) seconds the chiller will shutdown and indicate a diagnostic.

Low Refrigerant Temperature Cut-out

The purpose of the low evaporator refrigerant temperature protection is to prevent water in the evaporator from freezing. When the LRTC trip point is violated, a latching diagnostic indicating the condition is displayed. The LRTC Diagnostic is active in both the Running and Stopped modes.

Figure 39. Cutout strategy

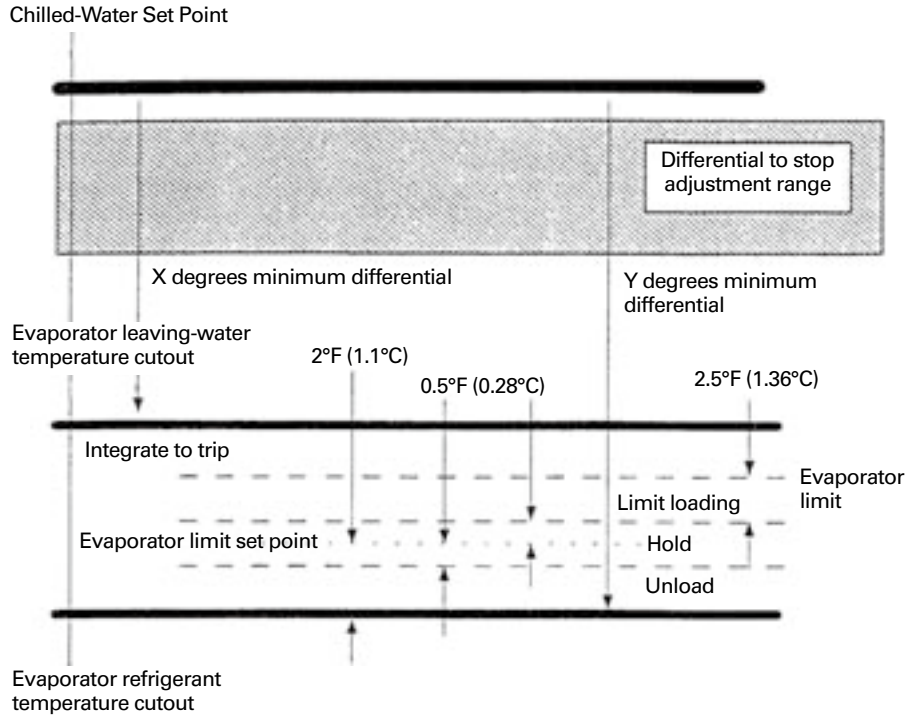

Condenser Limit

Condenser pressure is continuously monitored to provide a limit function that prevents High Pressure Cutout (HPC) trips. This protection is called Condenser Refrigerant Pressure Limit, or High Pressure Limit. A fully loaded compressor, operating at high Evaporator Leaving Water Temperature (ELWT) and high condenser temperatures causes high condenser pressures. The purpose of this limit is to avoid HPC trips by allowing the chiller to continue to run at a lower load instead of tripping off using HPC. The Condenser Limit will be based on a pressure conversion from the Condenser Refrigerant Temperature sensor. When limited by this action, "Condenser Pressure Limit" will be displayed as a sub-operating mode. The Condenser Limit Setpoint is factory set (93 percent of HPC), however can be changed using Tracer™.

Restart Inhibit

This function provides short cycle protection for the motor, and indirectly also short cycling protection for the starter since the starter is designed to operate the motor under all the conditions of motor performance.

Restart Inhibit Function Using Time Base

This method uses straight start-to-start timer to determine when to allow the next start. A Restart Inhibit Start-to-Start Time setpoint is used to set the desired start-to-start time.

Default is 20 minutes and can be altered using the UT™. A time based restart inhibit function is used if the Restart Inhibit Type is set to 'Time' using UT™ or if the motor winding temperatures are determined to be invalid.

Note: When the start is inhibited by the restart inhibit function, the time remaining will be displayed along with the restart inhibit mode. There is no 'free' start on a power up of the UC800 since a real time clock is used to determine when the next start will be allowed based on the start time of the previous start.

Low Oil Temperature Start Inhibit

When oil temperature is at or below the low oil temperature start inhibit setpoint (80-140°F/26.7-60°C), the heater is energized to raise the oil temperature.

Low oil temperature is indicative of refrigerant dilution in the oil. Oil temperature is used to estimate this dilution since the oil temperature directly corresponds to amount of refrigerant dilution in the oil. It is required that oil contains minimal refrigerant in it. This is accomplished by boiling the refrigerant out of the oil by maintaining a high enough oil temperature.

If enhanced oil temperature protection is disabled or below a given Low Oil Temperature Inhibit setting (default 95°F/35°C) the compressor cannot be started. This is an inhibit mode and will be reported to the operator interface.

The oil heater is energized in an attempt to raise the oil temperature over this inhibit temperature setpoint. The compressor is inhibited from starting until the oil temperature is raised 5°F (2.7°C) or more degrees above this setpoint.

The Low Oil Temperature Start Inhibit is tested on every start unless a quick restart is being performed during post-lube.

If the Enhanced Oil Temperature Protection setting is enabled, the Low Oil Temperature Start Inhibit value is 136°F (57.8°C).

If the Enhanced Oil Temperature Protection setting is not enabled, the Low Oil Temperature Start Inhibit value is settable with the Low Oil Temperature Start Inhibit Setpoint using the UT™.

Oil Temperature Control

The oil heater is used to maintain the oil temperature within +/- 2.5°F (1.4°C) of the oil temperature control setpoint. The oil heater is commanded off when the oil pump is commanded on.

If the oil temperature is at or below the Low Oil Temperature Cutout setpoint, this diagnostic will be issued and stops the compressor. This diagnostic is ignored for the first

Machine Protection and Adaptive Control

10 minutes of compressor run. After that, if the oil temperature falls below this cutout temperature for more than 60 consecutive seconds this diagnostic is issued.

Low Oil Temperature Cutout

If the oil temperature is at or below the Low Oil Temperature Cutout, for more than 60 consecutive seconds this diagnostic will be issued stopping the compressor.

This diagnostic does not take affect during the first 10 minutes of compressor run.

High Oil Temperature Cutout

This is a latching diagnostic resulting in an immediate shutdown. Default Setpoint value: 165°F (73.9°C) Implemented to avoid overheating of the oil and the bearings.

If the oil temperature is at or above the High Oil Temperature Cut-out setpoint this diagnostic will be issued, which will stop the compressor. If Oil Temperature violates this temperature cut-out for more than 120 seconds, this diagnostic is issued.

Manual Oil Pump Control

The oil pump control accepts commands to turn on the oil pump. The manual oil pump choices will be "Auto" or "On." When the oil pump is commanded "On," it will revert to "Auto" in 10 minutes, and is adjustable at Large display™ or UT™.

Controls Chilled Water Reset (CWR)

Chilled water reset is designed for those applications where the design chilled water temperature is not required at partial load. In these cases, the leaving chilled water temperature setpoint can be reset upward using the CWR features.

When the CWR function is based on return water temperature, the CWR feature is standard. When the CWR function is based on outdoor air temperature, the CWR feature is an option requiring an outdoor temperature sensor.

The type of CWR is selected in the Operator Interface settings Menu along with the Reset Ratio, Start Reset Setpoint, and the Maximum Reset Setpoint.

High Lift Unloading (500 Ton Family Only)

High Lift Unloading Valve directs discharge gases from the condenser through a solenoid valve directly into the economizer. From the economizer, this gas then flows to the second stage compressor where the economizer normally is connected. The purpose of HLUV is to increase the gas flow rate through the second stage compressor. Bypass gas is allowed to occur using an inline normally closed solenoid valve. The high lift unloading function is dependent on the lift (where lift is defined as the difference between Condenser Saturated Refrigerant Temperature and the Evaporator Saturated Refrigerant Temperature) and on chiller load. When the high lift unloading mode is entered, the High Lift Unloading valve is opened and the inlet guide vane close travel is limited.

The HLUV valve does not modulate the flow rate, but rather is either open or closed. Further, the valve was sized to handle a mass flow sufficient to permit operation below 35% IGV position but not necessarily to 0%. The valve was sized to permit substantial but incomplete unloading and yet was kept as small as practicable to minimize power requirements with HLUV operation.

Not all CVGF chillers require the bypassing of condenser gas. In some tonnages, the

High Lift Unloading Valve and copper lines do not exist. The LLID (1A9) with the High Lift Unloading relay always exists.

Note: There is noticeable noise, due to gas flow, when the high lift unloading valve is open.

Functional Description

The following equation determines action of the high lift unloading function:

$$\text{Trigger IGV\%} = 0.98 * \text{Lift} + \neg$$

$$0.065 * \text{CPIM} + C$$

Where Lift is defined as Condenser Saturated Refrigerant Temperature minus Evaporator Saturated Refrigerant Temperature in °F. The CPIM is the average impeller diameter in inches times 100.

High Lift Unloading Solenoid

The normally open contact of a AdaptiView control relay powers the normally closed high lift unloading valve solenoid with the following logic:

LLID Relay State	High Lift Unloading Valve Solenoid	High Lift Unloading Valve	Function
De-energized	De-energized	Closed	No condenser gas bypass
Energized	Energized	Open	Bypass condenser gas

The high lift unloading valve opens if the compressor is running and the IGV position is at or below the Trigger IGV% line

– 5%. The high lift unloading valve closes when the IGV position reaches the Trigger IGV% + 5% or the compressor shuts down.

Note that this 5% is of the full IGV travel range of 100%. Also note that operation of the high lift unloading valve is independent of the high lift unloading limit mode as stated below.

High Lift Unloading Limit Mode

For a Gear Drive chiller, the minimum IGV position is 60% of the Trigger IGV%. When the IGV movement is being limited to the 60% of the Trigger IGV% point, the high lift unloading limit submode is displayed.

Compressor Start Up

At compressor startup, the chiller is initialized as to not be in high lift unloading. The rules to enter high lift unloading mode are as stated above. Also at startup, sufficient time should be allowed so that an accurate Trigger IGV% may be calculated. Here non-saturated conditions exist right away resulting in unstable temperature measurements.

Manual Capacity Control

This is the Compressor Control Signal mode override in Large display™. Here high lift unloading solenoid valve operation, 60% of the Trigger IGV% and displaying of the high lift unloading limit submode is obeyed.

Chiller Shutdown

The high lift unloading valve is normally closed (de-energized). There is no check performed to ensure the valve is closed without using UT™.

Pre-Commissioning Bump Start Procedure

Note: The following procedure is a requirement prior to the first start of the chiller. Failure to complete may result in damage to the compressor and void the warranty.

Procedure

1. Complete all control settings.
2. Ensure water flows in the condenser and evaporator are correct according to the pre-commissioning procedures.
3. Ensure the unit has been charged with the correct amount of refrigerant and oil and that the oil is the proper operating temperature.
4. Complete a phase rotation test if the voltage is less than 600 volts.
The following checks require TWO personnel to complete. During the bump start of the compressor, one person will look at the rotor from the rear of the motor through the sight glasses to determine correct direction. Looking at the sight glass, the direction will be counter-clockwise. Do not check the rotation of the motor after the start sequence has completed as the indication may be incorrect.
5. With the voltage applied to the mains on the starter, place the chiller in Auto mode.
6. After the pre-lube is complete, let the starter energize the motor, permitting a start.
7. After three seconds, activate the emergency stop by pressing the Immediate Stop button at the AdaptiView twice in quick succession. During this three second period, the rotor should be seen to rotate in a counter-clockwise direction.
8. If the direction is incorrect, the 3 phases must be isolated from the power source and two legs swapped to obtain the correct direction.

Unit Startup Unit Start-Up Procedures

Daily Unit Start-Up

1. Verify the chilled water pump and condenser water pump starter are in "ON" or "AUTO."
2. Verify the cooling tower is in "ON" or "AUTO."
3. Check the oil tank oil level; the level must be visible in or above the lower sight glass. Also be sure to check the oil tank temperature; normal oil tank temperature before start-up is 140°F to 145°F (60° to 63°C).

Note: The oil heater is energized during the compressor off cycle. During unit operation, the oil tank heater is de-energized.

4. Check the chilled water setpoint and readjust it, if necessary, in the Chiller Settings menu.
5. Check the current limit setpoint and readjust it, if necessary, in the chiller settings menu.
6. Press <AUTO>.

Next, the AdaptiView checks the leaving evaporator water temperature and compares it to the chilled water setpoint. If the difference between these values is less than the start differential setpoint, cooling is not needed.

If the AdaptiView determines that the difference between the evaporator leaving water temperature and chilled water setpoint exceeds the start differential setpoint, the unit enters the initiate in the start mode, the oil pump and the condenser water pump are started. If condenser water flow is not proven (flow switch 5S2 does not close) within 4 minutes 15 seconds, the unit is locked out on a MMR Diagnostic.

Oil pressure must be verified within 3 minutes or a MMR diagnostic is generated.

When less than 5 seconds remain on the restart inhibit, the pre-start test is conducted on Y-Delta starters. If faults are detected, the unit's compressor will not start, and a MMR Diagnostic will be generated.

Note: Whenever the AdaptiView detects a MMR diagnostic condition during start-up, unit operation is locked out, and manual reset is required before the start-up sequence can begin again. If the fault condition has not cleared, AdaptiView will not permit restart.

When the cooling requirement is satisfied, the AdaptiView originates a "Shutting down" signal. The inlet guide vanes are driven closed for 50 seconds, and the unit enters a 1 minute post-lube period. The compressor motor and condenser water pump starter are de-energized immediately, but the oil pump continues to run during this 3 minute interval; the evaporator pump will continue to run. Once the post-lube cycle is done, the unit returns to auto mode.

Seasonal Unit Start-Up

Note: The following procedure is a requirement prior to the first start of the chiller. Failure to complete may result in damage to the compressor and void the warranty.

1. Close all drain valves, and reinstall the drain plugs in the evaporator and condenser headers.
2. Service the auxiliary equipment according to the start-up and maintenance instructions provided by the respective equipment manufacturers.
3. Vent and fill the cooling tower, if used, as well as the condenser and piping. At this

Unit Startup

- point, all air must be removed from the system (including each pass). Then close the vents in the condenser water boxes.
4. Open all of the valves in the evaporator chilled water circuit.
 5. If the evaporator was previously drained, vent and fill the evaporator and chilled water circuit. When all air is removed from the system (including each pass), close the vent valves in the evaporator water boxes.
 6. Lubricate the external vane control linkage as needed.
 7. Check the adjustment and operation of each safety and operating control.
 8. Complete all control settings.
 9. Ensure water flows in the condenser and evaporator are correct according to the pre-commissioning procedures.
 10. Close all disconnect switches.
 11. Ensure the unit has been charged with the correct amount of refrigerant and oil and that the oil is the proper operating temperature.
 12. Complete a phase rotation test if the voltage is less than 600 volts.
 13. Perform instructions listed in "Unit Start-up" section

⚠ WARNING

Live Electrical Components!

During installation, testing, servicing and troubleshooting of this product, it may be necessary to work with live electrical components. Have a qualified licensed electrician or other individual who has been properly trained in handling live electrical components performs these tasks. Failure to follow all electrical safety precautions when exposed to live electrical components could result in death or serious injury.

CAUTION

Refrigerant Loss May Occur:

To avoid excessive unit refrigerant pressure above the relief valve setting, follow these recommended procedures:

- Do not run the pump for more than 30 minutes after chiller shut-down. Failure to avoid excessive operation of the evaporator water pump with Chiller off may cause loss of refrigerant charge.
- If the chilled water loop is used for heating.
- Ensure that the evaporator is isolated from the hot water loop before changing over to the heating mode.

Unit Shutdown Unit Shutdown Procedures

Daily Unit Shutdown

Note: Refer to Start-Run Shutdown sequence (Figure 10).

1. Press <STOP>.
2. After compressor and water pumps shutdown turn Pump Contactors to OFF or open pump disconnects.

Seasonal Unit Shutdown

CAUTION

Refrigerant in Oil Pump

Damage may occur

The control power disconnect must remain closed to allow oil sump heater operation. Failure to do this will allow refrigerant to condense in the oil pump.

3. Open all disconnect switches except the control power disconnect switch.
4. Drain the condenser piping and cooling tower, if used.
5. To drain the condenser, remove the drain and vent plugs from the condenser headers.
6. Once the unit is secured for winter, the maintenance procedures described under "Annual Maintenance" in the Periodic Maintenance section of this manual should be performed by authorized Trane service technicians.

WARNING

Refrigerant Discharge Hazard!

DO NOT ALLOW CHILLER TO INCREASE IN TEMPERATURE OR PRESSURE WHILE THE UNIT IS OFF.

Continuous running of pumps while the chiller is off can increase the temperature or pressure and will result in premature release of refrigerant causing bodily harm and possible death to anyone in contact with refrigerant discharge



Periodic Maintenance

Periodic Maintenance

Overview

Use of a periodic maintenance program is important to ensure the best possible unit performance and efficiency.

Daily Maintenance Checks

Check the chiller's evaporator and condenser pressures, and discharge oil pressure.

IMPORTANT: IT IS HIGHLY RECOMMENDED THAT THE OPERATING LOG BE COMPLETED ON A DAILY BASIS.

Check the oil level in the chiller oil sump using the two sight glasses provided in the oil sump head. When the unit is operating, the oil level should be visible in the lower sight glass.

Weekly Checks

Check the following after the machine has been in operation for at least 30 minutes:

1. Chilled water and condenser water entering and leaving temperatures.
2. Current drawn by the compressor (Amps).
3. Oil level in the oil sump. The oil level must be visible in the sight glass.
4. Condenser pressure, evaporator pressure.
5. Unusual noise, vibration, and so forth

It is strongly recommended that unit readings and observations are recorded on a weekly log sheet.

The acceptance of a warranty claim may depend on this.

Annual Checks

The yearly maintenance should be performed by an authorized Trane service technician. It should include weekly checks.

1. Check setting and operation of all controls and safety devices.
2. Leak test the entire machine for refrigerant leaks.
3. Check starter contactors for wear and replace if required.
4. Check motor winding insulation.
5. Check motor amps draw.
6. Perform an oil analysis.
7. Perform vibration analysis.
8. Check and adjust the water flow
9. Check and adjust interlocks.
10. Clean condenser tubes.

Condenser cleaning

Water available for cooling condensers frequently contains minerals that collect on the condenser tube walls as carbonate scale. Scale accumulation rate will be increased by high condensing temperatures and water with a high mineral content.

Cooling towers, when used, may collect dust and form material that will deposit in the condenser tubes forming sludge.

Scale and sludge formation is indicated by high condensing temperatures and large differences between condensing and leaving water temperatures.

To maintain maximum efficiency, the condenser must remain free of scale and sludge. Even a very thin coating on the tube surface may greatly decrease condenser heat transfer capacity. Two methods for cleaning condenser tubes are mechanical and chemical.

CAUTION

Proper Water Treatment!

The use of untreated or improperly treated water in a CenTraVac may result in scaling, erosion, corrosion, algae and or slime conditions. It is recommended that the services of a qualified water treatment specialist be engaged to determine what water treatment, if any, is required. Trane assumes no responsibility for equipment failures which result from untreated or improperly treated water, or saline or brackish water.

The mechanical method removes sludge and loose material from the condenser tubes. Working a round nylon or bristle brush attached to a rod, in and out of the tubes loosens the sludge. After cleaning, flush the tubes with clean water.

The chemical method removes scale deposits. The standard condenser water circuit consists of copper, steel and cast iron. Any reliable water treatment company will be able to recommend a cleaning solution for the job.

Note: Trane assumes no responsibility if deterioration of the unit is due to inadequate water treatment.

Evaporator cleaning

The evaporator is part of a closed water circuit and should not accumulate an appreciable amount of scale or sludge. However, if cleaning should be required, use the same methods outlined for cleaning the condenser.

Note: Trane assumes no responsibility if deterioration of the unit is due to inadequate water treatment.

Controls checkout and adjustments

Controls are checked and calibrated during run-in of the unit prior to shipment. Any adjustments should be made exclusively by authorized Trane service technician.

It is strongly recommended to have proper functioning and setpoints of all controls checked once per year.

Control settings

For control calibration and check-out, contact an authorized Trane service technician.

Trouble Analysis

See the Diagnostic List for trouble shooting information. The diagnostic must be analyzed, corrections made by qualified personnel and the latching diagnostic reset be-

Periodic Maintenance

fore the chiller can be returned to operation.

Diagnostic Codes

A Latching diagnostic will shut down the machine or a part of the machine if so indicated. A latching diagnostic will require a manual reset to restore operation. A Non-latching diagnostic will shut down the machine or a part of the machine if so indicated. A non-latching diagnostic will automatically reset when the condition causing the diagnostic goes away. If a diagnostic is informative only, no machine action is taken except to load a diagnostic code into the last diagnostic register. Unless otherwise stated, all active diagnostics will be lost on loss of power.

Leak Testing Procedure

To leak-test the CVGF, weigh a one-pound charge of trace gas and bring the pressure up to a maximum of 75 psig (517 kPa) using dry nitrogen. This pressure has been found to be adequate to find leaks in a CVGF when using a sensitive electronic leak detector. Set the scale to "medium" which corresponds to a 1/2-ounce (.015l) per year leak rate and probe all joints thoroughly. Be sure and relieve the pressure in the unit before evacuation or leak repair. Local codes take precedence when conducting evacuation.

WARNING

⚠ Hazard of Explosion!

Use only dry nitrogen with a pressure regulator for pressurizing unit. Do not use acetylene, oxygen or compressed air or mixtures containing them for pressure testing. Do not use mixtures of a hydrogen containing refrigerant and air above atmospheric pressure for pressure testing as they may become flammable and could result in an explosion. Refrigerant, when used as a trace gas should only be mixed with dry nitrogen for pressurizing units. Failure to follow these recommendations could result in death or serious injury or equipment or property-only damage.

Taking an Oil Sample

To obtain an accurate oil sample, the chiller must be operating for a minimum of 30 minutes. An approved oil sample cylinder for R134a should be used. Make sure the upstream oil filter isolation angle valve is completely backseated in order to close the 1/4 inch Schrader valve port. Attach a low loss hose or line with a Schrader valve depressor to the oil sampling 1/4 inch Schrader valve located on the upstream oil filter isolation valve.

Attach the other end of the hose or the line to the oil-sampling cylinder. Evacuate the cylinder and hose or line to remove any non-condensables or moisture. Open the valve on the sample cylinder. Turn the upstream oil isolation angle valve stem approximately one turn clockwise to allow oil under pressure to enter the sample cylinder.

Weigh the cylinder as the oil is being transferred and shut off the cylinder valve when the desired weight of oil has been transferred. Backseat the angle valve to shut off oil flow and remove the hose from the Schrader valve. Be sure to replace the Schrader and angle valve cap and secure them when sampling is complete. Recover the oil and refrigerant from the oil sample hose or line with an approved R134a recovery unit.

When oil analysis indicates the need to change the oil (high acidity, moisture, and so

forth), use the following procedure for removing the oil.

Removing Compressor Oil

Make sure the unit is not running and the power has been disconnected to the oil heaters. To remove the compressor oil, attach an oil recovery and recharge hose or line to the oil sump drain valve located on the bottom of the oil sump (See Figure 40). Attach the refrigerant vapor return hose or line of the recovery unit to the condenser service valve. Open the oil sump drain valve and condenser service valve and activate the oil recovery process according to the operation specifications of the recovery unit. After all the oil has been recovered and residual R134a refrigerant vapor returned to the condenser, shut the oil drain valve and condenser service valve off and secure the caps to both valves.

Figure 40. CVGF compressor oil system component locations

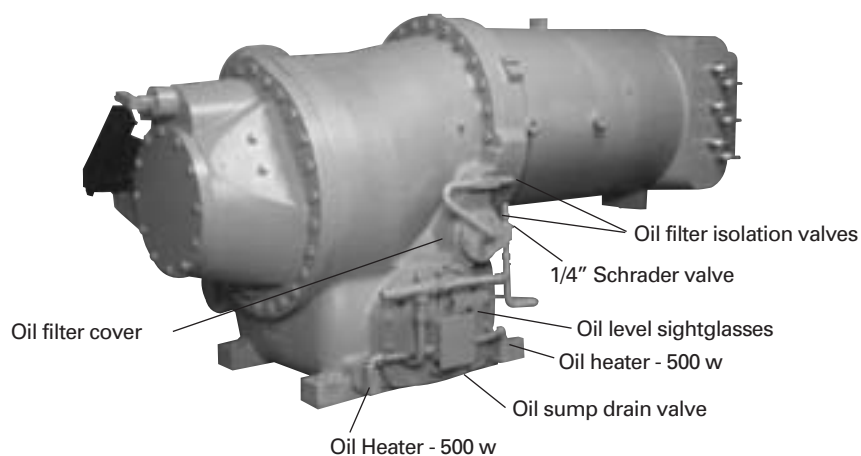

Periodic Maintenance

CAUTION OIL CONTAMINATION

Due to the hygroscopic properties of POE oil, all oil must be stored in metal containers. The oil will absorb water if stored in a plastic container.

Oil Charging

CVGF units ship factory charged with 15 gallons (56.8 l) of oil and a 5 psig (34 kPa) @ 70 °F (20°C) dry nitrogen holding charge.

Note: The correct oil charge for all CVGF units is 15 gallons (56.8 l) of Trane OIL00037 (Trane OIL00037 is R134a miscible oil in 1-gallon (3.785 l) containers). A 5 gallon (18.9 l) container of Trane approved R134a oil is available (Trane OIL00049). As with mineral oil, if water is in the system it will react with the oil to form acids. Use the following table to determine the acceptability of the oil.

POE Oil Properties	Acceptable Levels
Moisture content	less than 300 ppm
Acid Level	less than 0.5TAN (mg KOH/g)

Trane recommends subscribing to an oil analysis program to determine the condition of the oil rather than changing the oil on a periodic basis. This program will reduce the chiller's lifetime oil consumption and minimize refrigerant emissions. The oil analysis should be performed by a qualified laboratory, experienced in refrigerant and oil chemistry, and the servicing of Trane centrifugal chillers.

Oil Charging Procedure

Use appropriate oil as specified:

USA	Europe
Oil 0037	Oil 021E
Oil 0049	Oil 0020E

Unit Charged With Refrigerant

1. Decant the oil from the shipping container into the cylinder of an oil recovery and recharge unit per the unit operation instructions (15 gallons (56.8 l) required).
2. A vacuum of at least 500 microns must be attained and an oil temperature of at least 122°F (50°C) maintained to remove existing moisture. A standing vacuum rise test should be performed after the distillation process is complete to insure the oil has completely outgassed any moisture or non-condensibles. A vacuum rise of less than 100 microns (0.1 mm Hg) in a 2 hour period indicates the oil is ready for transfer.
3. Attach the oil transfer hose of the recovery unit oil pump to the oil sump charging and drain valve and evacuate.
4. Open the oil charging valve on the bottom of the oil tank of the CVGF and operate the oil recovery and recharge unit oil pump to charge the oil into the tank.
5. When the oil is at the center of the upper sight glass, stop the transfer of oil.
6. Energize the oil heaters.
7. At the control panel, go to the Service Tests menu and scroll down to the "oil

pump” screen. Turn the oil pump on in manual mode and let it run for several minutes. This will charge the oil lines and oil cooler with oil.

8. After shutting the oil pump off, check the oil level in the sump sight glasses. The level should be between the center of the upper glass and center of the lower sight glass. Float balls are installed in each sight glass to allow easy level determination.
9. If the oil level is below the center of the lower sight glass, charge oil into the sump as outlined in step 4.
10. Close the oil sump drain valve and remove the oil charging line.
11. Reinstall the oil drain valve cap and tighten securely.

Unit in a Vacuum.

1. Connect one end of an oil charging line to an oil supply (15 gallons (56.8 l) total required) and the other end to the oil sump drain valve located at the bottom of the oil sump (See Figure 40). If possible, evacuate the oil charging line to remove any non-condensables and moisture. This will require a shutoff valve on the oil supply side of the line and an access valve located on the line itself.
2. Open the oil sump drain valve and allow the vacuum to draw the oil into the sump until the upper sight glass ball is located in the center of the upper sight glass.
3. Close the oil sump drain valve and remove the oil charging line. Reinstall the oil drain valve cap and tighten securely.
4. Make sure the oil heaters are energized and the oil is up to temperature (greater than 122°F (50°C)).
5. Continue pulling a vacuum on the unit to remove any residual moisture or non-condensables, which may have been introduced during the oil charging. A vacuum of at least 500 microns (0.5 mm Hg) should be attained before blanking off the vacuum pump. A vacuum rise test should be performed to insure all non-condensables and moisture have been removed from the system before charging the unit with refrigerant 134a. The vacuum level should not rise by more than 100 microns (0.1 mm Hg) in a 2 hour period.
6. After charging the unit with refrigerant, operate the oil pump in the manual mode as outlined in step 7 in the preceding procedure and follow that procedure if additional oil is required to bring the level between the center of the two sight glasses.

Replacing the Oil Filter

The oil filter should not be changed unless absolutely required due to plugging, which will shut the chiller off on low oil pressure or if the oil is required to be changed. To replace the oil filter, use the following procedure:

1. Be sure the chiller is in the Stop mode.
2. Locate the two oil filter isolation valves (See Figure 40).
3. Connect an approved refrigerant recovery unit for R134a to the 1/4 inch Schrader valve on the oil filter inlet isolation valve to allow removal of oil and refrigerant from the oil filter cavity.
4. Close both isolation valves.
5. Recover the refrigerant and oil out of the oil filter cavity.
6. Remove the oil filter cover by removing the bolts and loosening the Roto-Lock connector on the outlet oil filter isolation valve.

Note:

When removed, do not allow any contaminants to get on the oil filter cover. Re-installing a contaminated oil filter cover could decrease the life of the compressor.

Periodic Maintenance

7. Remove the oil filter and o-ring.
8. Install a new oil filter, o-ring, and Roto-Lock nylon seal.
9. Replace the oil filter cover and torque the bolts and Roto-Lock connector. The cover is torqued to 19 lb-ft (2.62 N-m) and the Roto-Lock to 90 lb-ft (12.44 N-m).
10. Evacuate the oil filter cavity by attaching a deep vacuum pump to the 1/4 inch Schrader valve and pulling at least a 500 micron (0.5 mm Hg) vacuum. Do a standing vacuum rise test to determine if any leaks are present. If leak free, remove the vacuum pump from the valve.
11. Replace the Schrader valve cap and tighten.
12. Open both isolation valves.
13. On the Large display [™] display, select Settings, Mode overrides and select Oil Pump. Start and run the oil pump in manual mode to charge the oil filter with oil. Allow the pump to run for several minutes and shut the oil pump off by going back to the Auto mode at the control panel.
14. Check the oil level in the sump and if it is below the center of the lower sight glass, add oil by following the oil charging procedure outlined previously.

Oil Sump Heaters

The CVGF uses two 500 watt heaters to maintain the oil sump temperature at 136°F (57.7°C). These heaters are located in the lower oil sump casting, one on each side of the oil sump cover, and can be serviced without removing the refrigerant or oil, since the heaters are not located in the oil sump itself but in the casting (See Figure 40).

The AdaptiView will not allow the chiller to start unless the oil sump temperature is at least 30°F (16°C) above saturated evaporator temperature, or at least 105°F (58°C), whichever is higher. The oil sump comes factory insulated and must remain insulated to allow the oil temperature to maintain 136°F (57.7°C) while the unit is off.

The oil heaters are only energized during the unit “off” cycle to maintain oil temperature for startup. During the run cycle, the oil sump heaters are de-energized and the oil temperature may vary depending on load and operating conditions. The unit will trip on a latching diagnostic of high oil temperature if the oil exceeds 165°F (74°C).

Oil Pressure Protection

A differential oil pressure switch provides protection for the CVGF should the oil pressure fall below safe operating levels for any reason. This switch opens at 9 psid (62 kPa) and closes at 12 psid (82 kPa). The oil pressure regulator is factory set to maintain oil pressure between 18 to 22 psid (124-151 kPa). The unit will not start if the oil pressure is below 12 psid (82 kPa).

Adjusting the Oil Pressure Regulating Valve

The oil pressure regulator should be calibrated to maintain 18 to 22 psid during commissioning. In the event that the oil pressure switch will not close to allow unit startup, the following diagnostic procedure should be followed:

1. With the unit and the oil pump off, connect a pressure gauge to the service valve after the oil filter and another gauge to the Schrader valve located next to the oil pressure switch capillary on the oil sump. (An optional method is to use a differential pressure gauge instead of two separate gauges.)
2. On the Large display [™] display, select Settings, Mode overrides and select Oil

Pump. Place oil pump in manual mode. Check the oil pressure gauge readings and calculate the differential oil pressure by subtracting the oil sump pressure reading from the discharge oil pressure reading.

If the differential pressure is between 18 to 22 psid (124–151 kPa), the oil pressure regulating valve should not be adjusted. If the oil pressure switch is not closed at pressures above 12 psid (82kPa), the switch is defective and should be replaced. If the switch is closed the unit will not start due to a low oil pressure diagnostic. If the differential oil pressure cannot be achieved, the oil pump may be running backwards.

3. To reverse the oil pump motor rotation, two leads must be swapped on the oil pump motor contactor. Be sure to remove all power from the unit before doing any electrical wiring changes.

Note: Be sure to perform the Bump Start test to determine proper compressor rotation before operating the chiller.

If the differential oil pressure measured is below 12 psid (82 kPa), the oil filter may be plugging or the regulator may need adjustment.

4. Then check the pressure drop across the oil filter, connect a gauge to the service valve before the oil filter and another gauge to the service valve after the oil filter. Subtract the pressure reading taken from after the oil filter from the gauge before the oil filter to obtain the pressure drop. If the pressure drop is excessive (more than 8 psid (54 kPa)), shut the oil pump off and replace the oil filter per the procedure outlined previously.
5. When the oil filter change is completed, check the differential oil pressure and if it is below 18 psid (124 kPa), adjust the oil pressure regulator to obtain a reading of between 18 to 22 psid (124–151 kPa). If the pressure drop across the filter is not excessive, but the oil differential pressure is below 18 psid, adjust the oil pressure regulating valve to obtain 18 to 22 psid (124-151 kPa) oil pressure. To increase pressure, remove the oil pressure regulator cap and screw the regulator stem in a clockwise direction. Be sure to replace the cap and tighten when adjustment is complete.
6. Remove the pressure gauges when all diagnostic work is complete. Be sure and replace and secure any valve caps which were removed.

CVGF Oil Pump

The oil pump for the CVGF is a positive displacement, direct drive pump, three phase motor. The motor must be phased correctly to provide positive differential oil pressure. This pump and motor is located within the oil sump and can not be serviced without recovering the refrigerant and removing the oil from the machine.

Refrigerant Charge

If a low refrigerant charge is suspected, first determine the cause of lost refrigerant. Once the problem is repaired follow the procedures below for evacuating and charging the unit.

WARNING

Periodic Maintenance

Hazardous Voltage!

Disconnect all electric power, including remote disconnects before servicing. Follow proper lockout/tagout procedures to ensure the power can not be inadvertently energized. Failure to disconnect power before servicing could result in death or serious injury.

Evacuation and Dehydration

1. Disconnect ALL power while evacuating the system.
2. Connect the vacuum pump to the 5/8" flare connection on the bottom of the evaporator.
3. Remove all of the moisture from the system to insure a leak free unit. Pull the system down below 500 microns (0.5 mm Hg).
4. After the unit is evacuated, perform a standing rise test for at least an hour. This vacuum should not rise more than 100 microns (0.1 mm Hg) per hour to a maximum of 500 microns (0.5 mm Hg) over 12 hours. If the vacuum rises above this, either there is a leak or the unit has moisture present.

Note: If oil is in the system, this test is more difficult. The oil is aromatic and will give off vapors that will raise the pressure of the system. Check for oil temperature >122°F (50°C).

Refrigerant Charging

Once the system is leak and moisture free, use the 5/8" flare connections at the bottom of the evaporator and side of condenser to add refrigerant charge. See Unit Nameplate for correct refrigerant charge amounts.

Add the refrigerant charge as a vapor until the system pressure is above 29.4 psi (203 kPa) or Temperature is above 34°F (1°C). Liquid refrigerant may be added once these conditions are achieved.

CAUTION

Possible Freeze-up

Water can freeze during charging. Circulate water during charging to prevent freezing.

Caution

Charge vapor in the unit until:

- System pressure is above 29.4 psig (203 kPa)
- The saturation temperature of R134a is above 34°F (1°C)



www.trane.com

For more information, contact your local Trane office or e-mail us at service@trane.com



Literature Order Number	CVGF-SVX03B-EN
Date	March 2016
Supersedes	CVGF-SVX03A-EN, CVGF-SVU02B-E4, CVGF-SVN02C-E4

Trane has a policy of continuous product and product data improvement and reserves the right to change design and specifications without notice.