



Installation, Operation and Maintenance
Gas Heat
Performance Climate Changer™
CSAA Air Handlers
Sizes 6-120 for Indoor and Outdoor Units



⚠ SAFETY WARNING

Only qualified personnel should install and service the equipment. The installation, starting up, and servicing of heating, ventilating, and air-conditioning equipment can be hazardous and requires specific knowledge and training. Improperly installed, adjusted or altered equipment by an unqualified person could result in death or serious injury. When working on the equipment, observe all precautions in the literature and on the tags, stickers, and labels that are attached to the equipment.



Introduction

Read this manual thoroughly before operating or servicing this unit.

Warnings, Cautions, and Notices

Safety advisories appear throughout this manual as required. Your personal safety and the proper operation of this machine depend upon the strict observance of these precautions.

The three types of advisories are defined as follows:

⚠ WARNING Indicates a potentially hazardous situation which, if not avoided, could result in death or serious injury.

⚠ CAUTION Indicates a potentially hazardous situation which, if not avoided, could result in minor or moderate injury. It could also be used to alert against unsafe practices.

NOTICE Indicates a situation that could result in equipment or property-damage only accidents.

Important Environmental Concerns

Scientific research has shown that certain man-made chemicals can affect the earth's naturally occurring stratospheric ozone layer when released to the atmosphere. In particular, several of the identified chemicals that may affect the ozone layer are refrigerants that contain Chlorine, Fluorine and Carbon (CFCs) and those containing Hydrogen, Chlorine, Fluorine and Carbon (HCFCs). Not all refrigerants containing these compounds have the same potential impact to the environment. Trane advocates the responsible handling of all refrigerants-including industry replacements for CFCs and HCFCs such as saturated or unsaturated HFCs and HCFCs.

Important Responsible Refrigerant Practices

Trane believes that responsible refrigerant practices are important to the environment, our customers, and the air conditioning industry. All technicians who handle refrigerants must be certified according to local rules. For the USA, the Federal Clean Air Act (Section 608) sets forth the requirements for handling, reclaiming, recovering and recycling of certain refrigerants and the equipment that is used in these service procedures. In addition, some states or municipalities may have additional requirements that must also be adhered to for responsible management of refrigerants. Know the applicable laws and follow them.

⚠ WARNING

Proper Field Wiring and Grounding Required!

Failure to follow code could result in death or serious injury. All field wiring **MUST** be performed by qualified personnel. Improperly installed and grounded field wiring poses **FIRE** and **ELECTROCUTION** hazards. To avoid these hazards, you **MUST** follow requirements for field wiring installation and grounding as described in **NEC** and your local/state electrical codes.

⚠ WARNING

Personal Protective Equipment (PPE) Required!

Failure to wear proper PPE for the job being undertaken could result in death or serious injury. Technicians, in order to protect themselves from potential electrical, mechanical, and chemical hazards, **MUST** follow precautions in this manual and on the tags, stickers, and labels, as well as the instructions below:

- Before installing/servicing this unit, technicians **MUST** put on all PPE required for the work being undertaken (Examples; cut resistant gloves/sleeves, butyl gloves, safety glasses, hard hat/bump cap, fall protection, electrical PPE and arc flash clothing). **ALWAYS** refer to appropriate Safety Data Sheets (SDS) and OSHA guidelines for proper PPE.
- When working with or around hazardous chemicals, **ALWAYS** refer to the appropriate SDS and OSHA/GHS (Global Harmonized System of Classification and Labeling of Chemicals) guidelines for information on allowable personal exposure levels, proper respiratory protection and handling instructions.
- If there is a risk of energized electrical contact, arc, or flash, technicians **MUST** put on all PPE in accordance with OSHA, NFPA 70E, or other country-specific requirements for arc flash protection, **PRIOR** to servicing the unit. **NEVER PERFORM ANY SWITCHING, DISCONNECTING, OR VOLTAGE TESTING WITHOUT PROPER ELECTRICAL PPE AND ARC FLASH CLOTHING. ENSURE ELECTRICAL METERS AND EQUIPMENT ARE PROPERLY RATED FOR INTENDED VOLTAGE.**

⚠ WARNING**Follow EHS Policies!**

Failure to follow instructions below could result in death or serious injury.

- **All Trane personnel must follow the company's Environmental, Health and Safety (EHS) policies when performing work such as hot work, electrical, fall protection, lockout/tagout, refrigerant handling, etc. Where local regulations are more stringent than these policies, those regulations supersede these policies.**
- **Non-Trane personnel should always follow local regulations.**

Copyright

This document and the information in it are the property of Trane, and may not be used or reproduced in whole or in part without written permission. Trane reserves the right to revise this publication at any time, and to make changes to its content without obligation to notify any person of such revision or change.

Trademarks

All trademarks referenced in this document are the trademarks of their respective owners.

Revision History

- Updated Performance air handler section nameplate figure in Introduction chapter.
- Changed 0 to 10 Vdc to 2 to 10 Vdc in Installation chapter.
- Updated Flue connection sizes for gas heat sections figure in Installation chapter.
- Updated Duct Connection section in Installation chapter.
- Added Gas heat internal piping penetration location and Gas heat external piping penetration location figures in Piping chapter.
- Updated Airflow direction label figure in Installation chapter.
- Added Gas heat-Power exhaust figure in Wiring chapter.



Table of Contents

Overview of Manual	5	Heat Exchanger Condensate Piping	18
Nameplate	5	Wiring	19
General Information	6	Wiring Checklist	19
Product Information	6	High-Voltage Wiring	19
Burner Specifications	6	Wiring Entrance Locations	19
Description	7	Gas Heaters with 200–1000 MBh Output	20
Pre-Installation	9	Gas Heaters with 1250–2400 MBh Output	20
Receiving and Handling	9	Low-Voltage Wiring	20
Inspection	9	Start Up	26
Packaging/Shipping	9	Pre-Startup Checklist	26
Handling	9	Unit Operation	27
Receiving Checklist	9	Pre-Purge and Pilot Ignition	27
Jobsite Storage	10	Main Burner Ignition	28
Outdoor Storage	10	Pre-Purge and Main Flame Ignition	28
Dimensions and Weights	11	Final Check Out	29
Service Clearances	11	Normal Shutdown	29
Section Dimensions and Weights	12	Seasonal Startup/Shutdown	29
Installation	13	Seasonal Shutdown	29
Contractors' Responsibilities	13	Seasonal Startup	30
Installing Contractor	13	Heating Mode Maintenance	31
Electrical and/or Controls Contractor	13	Service Personnel Maintenance	31
Lifting and Rigging	14		
Placement and Assembly	14		
Flue Stack for Outdoor Air Handlers	14		
Installation	14		
High Altitude Installations	14		
Installing Outdoor Flue Stacks	14		
Installing Indoor Flue Stacks	15		
Installing Rain Hood/Combustion Air Inlet	15		
Installing Flue Stack for Hurricane Applications	15		
Duct Connections	16		
Combustion Air Duct	16		
Duct Transitions	16		
Airflow Direction	16		
Piping	17		
Gas Piping	17		
Proper Gas Pressure	18		



Introduction

Overview of Manual

Use this manual to install, startup, operate, and maintain the Performance Climate Changer™ air handler gas heat

section. Carefully review the procedures discussed in this manual to minimize installation and startup difficulties.

Nameplate

Each air handler section includes a nameplate/label (see Figure 1), which identifies the type of section, customer tagging information, the unit serial number, the unit order number, the build-section position for installation, and the unit model number.

Note: The unit serial number and order number is required when ordering parts or requesting service for a Trane air handler

Figure 1. Performance air handler section nameplate

Performance Climate Changer™ Air Handler

Order No.	A5K703A B/M A		
Serial No.	K01K12345		
Unit Model No.	CSAA006UAC00		
Tag ID	AHU-1		
Build Section	2 of 2		

Airflow

GAS HEATSECTION				
NATURAL GAS		MAX	MIN	
INPUT – MBH/HR		375	125	
OUTPUT – MBH/HR		300	100	
GAS INLET PRESS – IN. W.C.		14	7	
MANIFOLD PRESS – IN. W.C.		3.7	0.41	
TEMPERATURE RISE – F		91	30	
EXT STATIC PRESS – IN. W.C.		2.5		
INPUT V/HZ/PH	115/60/3	MCA	11.4	MOP 15.0
BURNER V/HZ/PH	120/60/1	FLA	4.3	HP 0.25
CONT CKT V/HZ/PH	120/60/1	A	6.0	

GAS-FIRED

LISTED
GAS HEATING SECTION
OF A CENTRAL STATION
AIR HANDLER – 541R

CLEARANCES TO COMPBUSTIBLE MATERIAL:

FLUE: 6 inches

CABINET: 0 inches

DUCT: 2 inches for 3 feet; 0 inches thereafter

Note: Reference burner nameplate for recommended gas manifold pressure at startup.

Manufactured under one or more of the following patent numbers:
5396782, 5674125, 6237354, 6973795, 7017356, 7150314, 7178355, 7340906, 7389646, 7526903, 7685834,

Trane
www.trane.com
Made in USA



General Information

Product Information

Model and serial numbers for the gas heat section are designated on the nameplate located on the piping-side access door inside the section. Record the information below for a permanent record of the equipment installed on your job site. The nameplate also contains the range of

settings for which the gas heat unit is capable. Record and retain these settings in case the unit should ever need adjustment after service repairs.

Note: This information is required when ordering repair parts.

Model Number _____
Serial Number _____
Air Handler Sales Order Number _____
Air Handler Serial Number _____
Startup Date _____
Altitude Above Sea Level _____
Calorific Value _____

Burner Specifications

Maximum Firing MBh _____
Minimum Firing MBh _____
Type of Gas _____
Maximum Inlet Gas Pressure _____
Minimum Inlet Gas Pressure _____
Temperature Rise (°F) _____
Manifold Pressure at Maximum MBh _____

Table 1. Motor and Electrical Specifications

Specifications	Gas Heater Input Power	Burner Motor ^(a)	Control Power ^(a)	Exhaust Motor
Volts		115	115	
Hertz	60	60	60	60
Phase		1	1	
HP	n/a		n/a	
FLA/Amps	n/a		6	
MCA		n/a	n/a	n/a
MOP		n/a	n/a	n/a

(a) Powered by a "line to 115 volt" transformer for all gas heaters except 115/60/1 rated units.

Description

The gas heat section consists of a drum-and-tube heat exchanger, burner, gas train components, and a control panel for electrical connections. It is an integral part of the entire air-handling system.

An access door is provided for service and maintenance of the burner and gas train components.

The gas heat section must be in a blow-thru position downstream from the supply fan. Downstream sections must be separated by a blank access section and discharge temperatures must be controlled so as not to exceed the

temperature limits of components in the downstream sections.

Depending on the heater size, an external vestibule that extends the width of the gas heat section may be used to house the burner and gas train components (see [Figure 2](#)). The external vestibule, if required, ships attached to the gas heat section. Some heaters have gas train components in an internal vestibule (see [Figure 3](#)). Refer to [Table 2](#) for vestibule locations.

Figure 2. Gas heat section with external vestibule



Figure 3. Gas heat section with internal vestibule

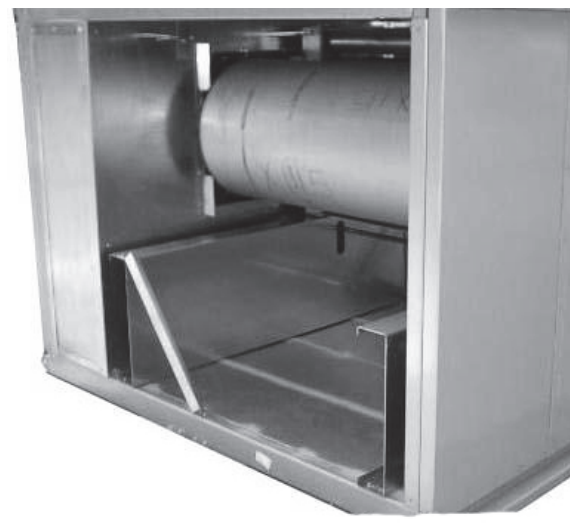

Table 2. Vestibule locations

Unit Size	Gas Output (MBh)	Vestibule Type	Unit Size	Gas Output (MBh)	Vestibule Type	Unit Size	Gas Output (MBh)	Vestibule Type
6	200	Ext	35	320/360	Int	66	700	Int
6	300	Ext	35	560	Int	66	860	Int
8	200	Ext	35	700	Int	66	1000	Int
8	300	Ext	35	860	Int	66	1250	Int
10	200	Ext	35	1000	Ext	66	1500	Int
10	320/360	Ext	35	1250	Ext	66	1750	Int
12	200	Int	35	1500	Ext	66	2000	Ext
12	320/360	Ext	35	1750	Ext	66	2400	Ext
14	200	Int	40	560	Int	80	860	Int
14	320/360	Ext	40	700	Int	80	1000	Int
17	200	Int	40	860	Int	80	1250	Int
17	320/360	Ext	40	1000	Ext	80	1500	Int
17	560	Ext	40	1250	Ext	80	1750	Int
17	700	Ext	40	1500	Ext	80	2000	Ext
21	200	Int	40	1750	Ext	80	2400	Ext
21	320/360	Ext	50	560	Int	100	1000	Int



General Information

Table 2. Vestibule locations (continued)

Unit Size	Gas Output (MBh)	Vestibule Type	Unit Size	Gas Output (MBh)	Vestibule Type	Unit Size	Gas Output (MBh)	Vestibule Type
21	560	Ext	50	700	Int	100	1250	Int
21	700	Ext	50	860	Int	100	1500	Int
21	860	Ext	50	1000	Int	100	1750	Int
21	1000	Ext	50	1250	Ext	100	2000	Int
25	320/360	Ext	50	1500	Ext	100	2400	Ext
25	560	Ext	50	1750	Ext	120	1000	Int
25	700	Ext	50	2000	Ext	120	1250	Int
25	860	Ext	57	560	Int	120	1500	Int
25	1000	Ext	57	700	Int	120	1750	Int
30	320/360	Int	57	860	Int	120	2000	Int
30	560	Int	57	1000	Int	120	2400	Int
30	700	Int	57	1250	Ext			
30	860	Int	57	1500	Ext			
30	1000	Ext	57	1750	Ext			
			57	2000	Ext			



Pre-Installation

Receiving and Handling

Inspection

Upon delivery, thoroughly inspect all components for any shipping damage that may have occurred, and confirm that the shipment is complete. See "Receiving Checklist" for detailed instructions.

Note: Delivery cannot be refused. All units are shipped F.O.B. factory. Trane is not responsible for shipping damage.

Packaging/Shipping

Gas heat sections arrive at the jobsite with an integral base frame for the purpose of mounting units to a housekeeping pad or roof curb. The base frame variables in height from the standard 2.5 inches to 8 inches.

Outdoor gas heat sections ship with wooden blocks fastened under the base channel. The blocks elevate the section for shipping protection and ease of handling. Leave the wooden blocks attached until the section is placed in its final position to avoid bending the base channel during rigging and handling.

Protective Covering

The large openings of the gas heat section are protected by an Oriented Strand Board (OSB) panel covering. The OSB panel is held in place by sheet metal screws. Leave the covering attached to the section until it is ready to install to prevent debris from entering the section.

Flue Stack

A stainless-steel flue stack is provided with outdoor air handlers. It ships inside the gas heat section or in one of the other sections of the air handler, and must be mounted on the flue opening on the side of the unit.

NOTICE

Equipment Damage!

Do not use type B flue stacks with this product as they are not suitable for the flue gas temperatures. Failure to follow this recommendation could result in equipment damage.

Hardware Kits

Hardware kits ship inside the air handler fan section in a plastic bag or cardboard box. This kit contains gasketing and screws. For outdoor units, roof joint connection strips and wall panel seam caps are included. These are used when fastening the gas heat section to the air handler. Keep the hardware with the gas heat section until it is ready to install.

Rain Hood

A rain hood is provided for outdoor units with internal vestibules. The rain hood is shipped on a separate wood skid. A kit containing mounting hardware ships inside the gas heat section and must be removed before assembly to the air handler.

Instruction Manuals

Individual instruction manuals for all of the gas train components (such as flame-control relay valves, pressure switches, and actuators) ship inside the piping vestibule. Retain these manual for future repair or troubleshooting.

Handling

The gas heat section is designed with the necessary number of lift points for safe installation. The lift points are designed to accept standard rigging devices and are removable after installation.

Indoor sections size 3-30 will be shipped with a shipping skid designed for forklift transport. If shipped on a skid, do not remove the gas heat section from the skid at this time.

Receiving Checklist

Complete the following checklist immediately after receiving shipment to detect possible shipping damage.

- Check to ensure that the shipment is complete. Small components may ship inside the unit or ship separately. Check the parts list to ensure all materials are present. If any component is missing, contact your local Trane sales office.
- Check all units, components, connections, and piping. Check all doors, latches and hinges. Inspect interior of each unit or section. Check for rattles, bent corners, or other visible indications of shipping damage.
- If a unit is damaged, make specific notations concerning the damage on the freight bill. Do not refuse delivery.
- Notify the carrier's terminal of the damage immediately by phone and mail. Request an immediate joint inspection of the damage by the carrier and consignee.
- Notify your Trane sales representative of the damage and arrange for repair. Do not attempt to repair the unit without consulting the Trane representative.
- Inspect the unit for concealed damage as soon as possible after delivery. Report concealed damage to the freight line. It is the receiver's responsibility to provide reasonable evidence that concealed damage did not occur after delivery. Take photos of damaged material if possible.

Note: Concealed damage must be reported within 15 days of receipt.



Jobsite Storage

Indoor air handlers and field-installed accessories must be protected from the elements. A controlled indoor environment is recommended for proper storage.

Note: All factory shipping protection should be removed, This wrapping is for transit protection only.

The unit controller and all other electrical/electronic components should be stored in conditions of -20°F to 120°F and 5 to 95 percent relative humidity, non-condensing. Electrical components are not moisture-tolerant.

Gas heat sections for outdoor units require no special protection for storage prior to installation.

Outdoor Storage

NOTICE:

Corrosion!

Use only canvas tarps to cover air handlers and components. Plastic tarps can cause condensation to form in and on the equipment, which could result in corrosion damage or wet storage stains.

Outdoor storage is **not** recommended for units that will be installed indoors. However, when outdoor storage is necessary, several things must be done to prevent damage:

Note: Keep the equipment on the original wooden blocks/skid for protection and ease of handling.

- Select a well-drained area, preferably a concrete pad or blacktop surface.
- Place the unit on a dry surface or raised off the ground to assure adequate air circulation beneath the unit and to assure no portion of the unit will contact standing water at any time.
- Cover the unit securely with a canvas tarp.
- Do not stack units.
- Do not pile other material on the unit.

Note: Trane warranty does not cover equipment damage due to negligence during storage.

Dimensions and Weights

Service Clearances

A minimum clearance of the section width plus 12 inches on the access door side of the gas heat section is recommended for routine maintenance. This clearance

provides enough room to replace the heat exchanger in the event of failure. The section side panels must be removed to access the heat exchanger. Refer to Figure 4 for service clearance recommendations for the air handler.

Figure 4. Service clearance for indoor units

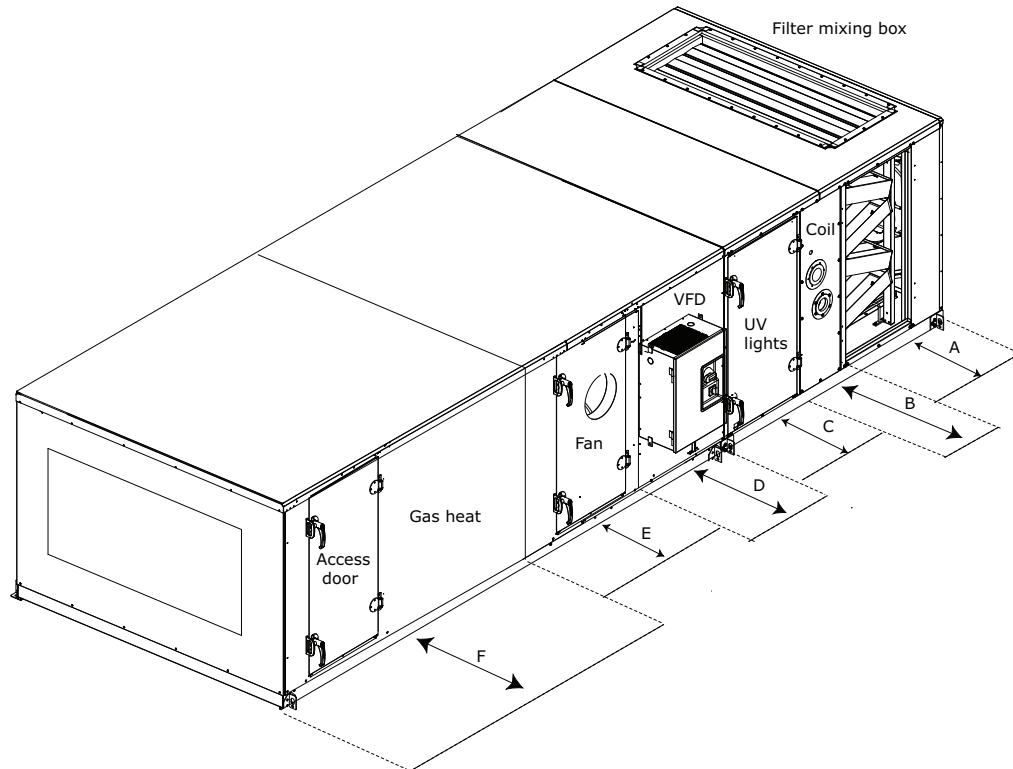

Table 3. Service clearance dimensions (inches)

Component	3	4	6	8	10	12	14	17	21	22	25	26	30	31	35	36	40	41	50	51	57	66	80	100	120				
A (filter)	48	48	48	48	48	48	48	48	48	48	48	48	48	48	48	48	48	48	48	48	48	48	48	48	48	52	56	58	58
B (coil, humidifier)	48	59	59	66	77	82	87	87	95	77	95	77	109	87	115	96	128	96	141	110	141	156	156	170	197				
C (UV Lights)	48	48	48	48	48	48	48	48	48	48	48	48	48	48	48	48	48	48	48	48	48	48	48	48	48	52	56	58	58
C (TCACS)	43	59	59	63	75	81	83	83	58	75	58	75	83	83	75	59	83	83	83	83	83	83	83	83	83	83	83	75	83
D (external motor control or low voltage panel)	61	61	61	61	61	61	61	61	64	64	64	64	64	64	64	64	64	64	64	64	64	64	64	64	64	64	64	64	64
D (internal starter or VFD)	48	48	48	48	48	48	48	48	48	48	48	48	48	48	48	48	48	48	48	48	48	48	48	48	48	48	48	48	48
E (fan)	48	48	48	48	51	54	58	61	60	51	66	51	66	58	66	60	70	60	77	66	77	93	93	101	101				
F (gas heat Ext Vestibule)	n/a	n/a	89	90	108	100	100	105	115	n/a	115	n/a	118	n/a	136	n/a	140	n/a	156	n/a	156	170	179	180	n/a				
F (gas heat Int Vestibule)	n/a	n/a	56	63	74	79	84	84	92	n/a	92	n/a	106	n/a	112	n/a	125	n/a	138	n/a	138	153	153	167	194				

Notes: At a minimum, the above clearance dimensions are recommended on one side of the unit for regular service and maintenance. Refer to as-built submittal for locations of items such as filter access doors, coil, piping connections, motor locations, hoods, pipe cabinets, etc. Sufficient clearance must be provided on all sides of unit for removal of access panels, plug panels, or section-to-section attachment brackets. Clearance for starters, VFDs, or other high-voltage devices must be provided per NEC requirements. For specific dimensional and weight information, refer to the unit submittals. The dimensions and weights in this manual are approximate. Trane has a policy of continuous product and product data improvement and reserves the right to change design and specifications without notice.



Dimensions and Weights

Section Dimensions and Weights

Table 4. Section dimensions (inches) and weights (pounds) - unit sizes 3-30

Unit size	3	4	6	8	10	12	14	17	21	25
Height - indoor unit ^(a)	29.00	29.00	35.25	37.75	37.75	41.50	41.50	49.00	52.75	61.50
Width	31.50	44.00	44.00	50.50	61.50	66.50	72.00	72.00	80.00	80.00
Height for outdoor unit includes base drip lip ^(b)	36.25	36.38	42.63	45.13	45.13	49.25	49.25	56.75	60.50	69.25
Weight add for outdoor unit (lbs/in. of unit length)	1.66	1.91	1.91	2.04	2.27	2.40	2.51	2.51	2.68	2.68
Gas heat section										
- 200 MBh	n/a	n/a	57.00 752.92	57.00 797.85	59.00 852.48	57.00 912.57	57.00 937.05	60.00 1011.83	60.00 1074.91	n/a
- 300 MBh	n/a	n/a	73.00 901.27	73.00 953.49	n/a	n/a	n/a	n/a	n/a	n/a
- 320/360 MBh	n/a	n/a	n/a	n/a	77.00 1093.23	73.00 1131.38	68.00 1127.89	71.00 1211.08	69.00 1264.50	69.00 1348.04
- 560 MBh	n/a	n/a	n/a	n/a	n/a	n/a	n/a	71.00 1191.99	69.00 1246.59	65.00 1307.47
- 700 MBh	n/a	n/a	n/a	n/a	n/a	n/a	n/a	83.00 1479.92	75.00 1503.43	75.00 1599.35
- 860 MBh	n/a	n/a	n/a	n/a	n/a	n/a	n/a	n/a	81.00 1606.36	81.00 1711.24
- 1000 MBh	n/a	n/a	n/a	n/a	n/a	n/a	n/a	n/a	87.00 1364.25	90.00 1497.35
Unit size	30	35	40	50	57	66	80	100	120	
Height - indoor unit ^(a)	61.50	67.25	67.25	75.75	85.50	92.50	107.50	119.75	119.75	
Width	93.50	100.00	112.50	125.50	125.50	140.50	140.50	154.50	182.00	
Height for outdoor unit includes base drip lip ^(b)	69.25	75.00	75.00	84.38	94.13	97.63	112.63	124.88	124.88	
Weight add for outdoor unit (lbs/in. of unit length)	2.94	3.02	3.28	3.73	6.12	2.57	2.57	2.80	3.25	
Gas heat section										
- 200 MBh	n/a	n/a	n/a	n/a	n/a	n/a	n/a	n/a	n/a	n/a
- 300 MBh	n/a	n/a	n/a	n/a	n/a	n/a	n/a	n/a	n/a	n/a
- 320/360 MBh	66.00 1298.88	66.00 1402.11	n/a	n/a	n/a	n/a	n/a	n/a	n/a	n/a
- 560 MBh	66.00 1441.79	66.00 1594.61	64.00 1468.07	64.00 1853.53	64.00 1900.53	n/a	n/a	n/a	n/a	n/a
- 700 MBh	76.00 1745.65	73.00 1895.19	75.00 1804.11	74.00 2190.52	74.00 2241.91	74.00 2490.63	n/a	n/a	n/a	n/a
- 860 MBh	76.00 1804.77	80.00 2046.29	75.00 2098.72	74.00 2280.52	74.00 2331.91	74.00 2580.63	74.00 2198.81	n/a	n/a	n/a
- 1000 MBh	85.00 1560.01	80.00 1723.73	81.00 1844.68	77.00 2325.57	77.00 2082.86	74.00 2300.63	74.00 1918.81	84.00 3156.04	92.00 3125.34	
- 1250-1750 MBh		101.00 2540.84	105.00 2717.94	106.00 3264.84	106.00 2942.76	109.00 3309.39	109.00 2949.68	92.00 3878.54	102.00 3886.60	
- 2000 MBh		n/a		114.00 3758.71	114.00 3430.29	112.00 3688.33	112.00 3320.33	109.00 4503.52	109.00 4391.21	
-2400 MBh		n/a			n/a	118.00 3890.31	112.00 3455.33	121.00 4715.85	119.00 4668.51	

(a) Height includes standard 2.5-inch base frame for sizes 3-57 and 6-inch base frame for sizes 66-120.

(b) Height includes 6-inch base frame for sizes 3-120.

Installation

⚠ WARNING

Improper Unit Lift!

Do not lift unit from top! Lift unit from lifting lugs only located at bottom of unit. Test lift unit approximately 24 inches to verify proper center of gravity lift point. To avoid dropping of unit, reposition lifting point if unit is not level. Failure to properly lift unit could result in unit dropping and possibly crushing operator/technician which could result in death or serious injury and possible equipment or property-only damage.

⚠ WARNING

Heavy Objects!

Ensure that all the lifting equipment used is properly rated for the weight of the unit being lifted. Each of the cables (chains or slings), hooks, and shackles used to lift the unit must be capable of supporting the entire weight of the unit. Lifting cables (chains or slings) may not be of the same length. Adjust as necessary for even unit lift. Other lifting arrangements could cause equipment or property damage. Failure to follow instructions above or properly lift unit could result in unit dropping and possibly crushing operator/technician which could result in death or serious injury.

⚠ WARNING

Hazardous Gases and Flammable Vapors!

Exposure to hazardous gases from fuel substances have been shown to cause cancer, birth defects or other reproductive harm. Improper installation, adjustment, alteration, service or use of this product could cause flammable mixtures or lead to excessive carbon monoxide. To avoid hazardous gases and flammable vapors follow proper installation and set up of this product and all warnings as provided in this manual. Failure to follow all instructions could result in death or serious injury.

⚠ WARNING

Combustible Materials!

Maintain proper clearance between the unit heat exchanger, vent surfaces and combustible materials. Refer to unit nameplate and installation instructions for proper clearances. Improper clearances could result in combustible materials catching on fire. Failure to maintain proper clearances could result in death or serious injury or property damage.

Contractors' Responsibilities

Installing Contractor

- Unpack the gas heat section and remove the skid.
- Remove protective coverings.
- Rig and/or move the section to the air handler location. The contractor must provide slings, spreader bars, clevis hooks, pins, etc. for rigging.
- For outdoor gas heat sections, a level roof curb or structural steel support system is required. If the gas heat section is provided with an external piping vestibule, no support is required for the vestibule.
- For outdoor sections, install the flue stack. The flue must be removed from the airstream before assembly. Install the flue stack on the gas heat section *before* assembling the gas heat section to the air handler.
- Clear debris from combustion air inlets located on the side or bottom of the gas heat section. Remove any debris obstructing combustion air inlets.
- In areas where snow drifts are higher than the bottom of the vestibule, a hood or louver may have to be installed for combustion air.
- Assemble the gas heat section to the air-handling system. Refer to *CLCH-SVX07*-EN Performance Climate Changer™ Air Handler Installation, Operation, and Maintenance* manual for specific assembly instructions. This manual ships inside the supply fan section of the air handler.
- Penetrate the unit casing and connect the supply gas line to the gas train.
- For indoor gas heat sections, install a field-engineered flue stack according to local codes.

Electrical and/or Controls Contractor

- Provide power to the gas heat section. See "[Wiring](#)," p. 19 for power requirements.
- Provide a binary start-stop signal.
- Provide an analog 2 to 10 Vdc modulating signal. A 2 to 10 Vdc interface module is installed as standard equipment. A 4 to 20 mA interface module is available and may have been installed on the unit for the control signal in lieu of the 2 to 10 Vdc signal.
- Provide an interlock in the start-stop signal circuit with the air handler supply fan. This interlock must insure the start-stop signal is interrupted to the gas heat system if the supply fan is shut off. The gas heat system must not operate without the supply fan providing airflow.
- All wiring must comply with applicable local and National Electric Code (NEC) specifications.

Installation

- For VAV units, provide temperature sensors for entering and leaving air in gas heat section.

Note: All power and control wiring for the gas heat section must be field-provided. All power and control wiring for any section downstream of the gas heat must be field-provided.

Lifting and Rigging

Refer to *CLCH-SVX07*-EN Performance Climate Changer™ Air Handler Installation, Operation, and Maintenance* manual for instructions on equipment rigging and lifting. This manual ships inside the unit fan section.

Placement and Assembly

Refer to the design engineer's plans and submittals for the location of the gas heat section in the air handler. The gas heat section will arrive at the job site as an individual section. It is not shipped with the air handler.

Hardware for fastening the gas heat section to the air handler can be found in the unit fan section.

Final assembly of the air handler should be done at the unit installation site. Refer to *CLCH-SVX07*-EN Performance Climate Changer™ Air Handler Installation, Operation, and Maintenance* manual for instructions on equipment assembly.

Flue Stack for Outdoor Air Handlers

The flue stack for outdoor air handlers must be mounted on the flue opening on the side of the unit. The flue stack must be installed on the gas heat section *before* assembling the gas heat section to the air handler. It is very difficult to remove the flue from inside the unit once the unit is assembled.

Installation

High Altitude Installations

⚠ WARNING

Hazard of Explosion!

Installations at altitudes of 3,000 feet above sea level or higher may require adjustment of the air-fuel linkage for proper combustion. Linkage and air-fuel adjustment should only be done by an experienced, qualified gas heat technician. Failure to follow these recommendations could result in death or serious injury or equipment or property-only damage.

Adjustment of gas train linkages is not normally required. However, for high altitude installations, adjustment to the air-fuel linkages may be necessary for proper combustion. Heater outputs must be derated four percent for every 1000 feet over 2000 feet above sea level. When specifying gas heaters, the engineer should provide the MBh and

airflow required at altitude. All Trane literature is based on nominal outputs at sea level.

It is recommended that the services of an experienced, qualified gas heat technician be employed to adjust air-fuel linkages for proper combustion.

Installing Outdoor Flue Stacks

The flue stack for outdoor gas heat sections ships inside the gas heat section or in one of the other sections of the air handler.

Figure 5. Outdoor air handler flue stack

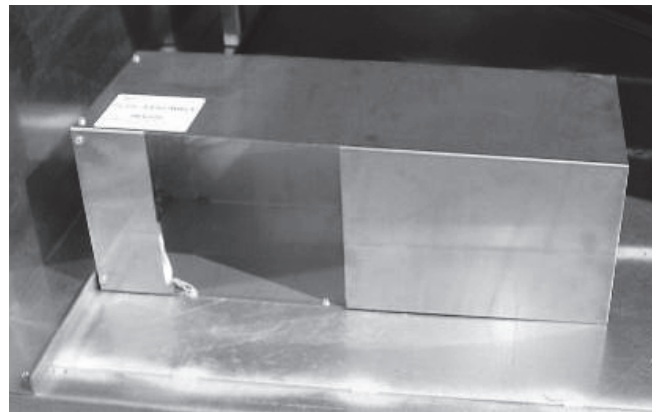

Attach the flue stack to the flue collar and secure it with screws as indicated in [Figure 6](#).

A field-provided rain hood or screen is recommended on the flue to prevent possible blockage from bird nests and beehives.

Figure 6. Outdoor air handler flue stack installation

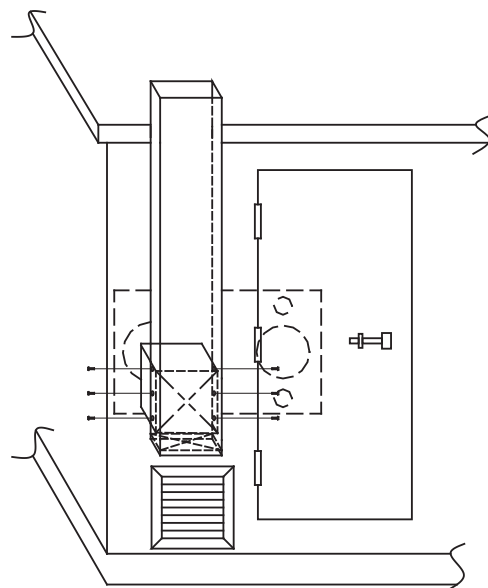

[Table 5](#) shows flue connection sizes for the gas heat section.

Table 5. Flue connection sizes for gas heat sections

Gas Output (MBh)	Flue Size (inches)
200, 320, 360, 560	8 x 8
300	9 x 9
700, 860, 1000	12 x 12
1250, 1500, 1750	10 x 10
2000, 2400	14 x 14

Installing Indoor Flue Stacks

Gas heat sections for indoor air handlers require a field-engineered and field-installed flue stack. Local codes and practices vary throughout the country. The engineer should size the flue based on MBh output, horizontal and vertical run lengths, type of flue material, NFPA 54 Fuel Gas Code, and local codes. The flue should be designed for 800 degrees F (430 degrees C). If horizontal runs over 20 feet or other static-increasing transitions are necessary, a flue booster fan will be required.

Install according to local codes. See connection sizes in [Table 5](#).

Installing Rain Hood/Combustion Air Inlet

Rain hoods are only required on an outdoor unit with an internal vestibule. Depending on unit size, the combustion air opening will be in the access door or in the side panel. A unit with an external vestibule has the combustion air opening in the floor of the vestibule and does not require a rain hood, unless excessive snowdrifts are expected.

Rain hoods for the combustion air opening ship loose and must be installed at the job site. The assembly consists of the hood, butyl tape and number 10 screws.

- Install butyl tape between the hood and the side panel or door panel (see [Figure 7](#)).

Figure 7. Installation of rain hood for combustion air opening

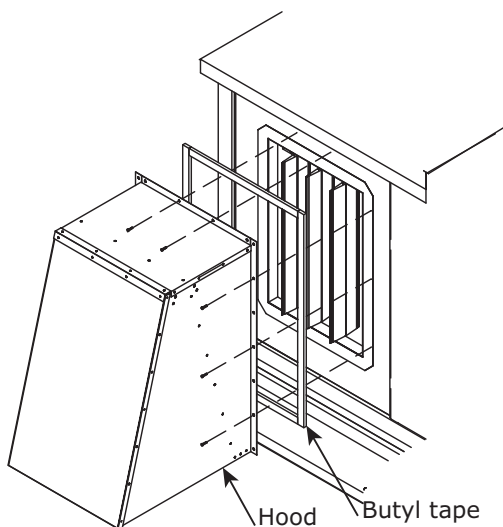

- Locate the bottom edge of the hood 2 3/8 inches below the bottom edge of the inlet air opening and center the

hood left-to-right over the inlet air opening (see [Figure 8](#)).

- Install the hood to the unit with number 10 screws.

Figure 8. Center inlet air opening

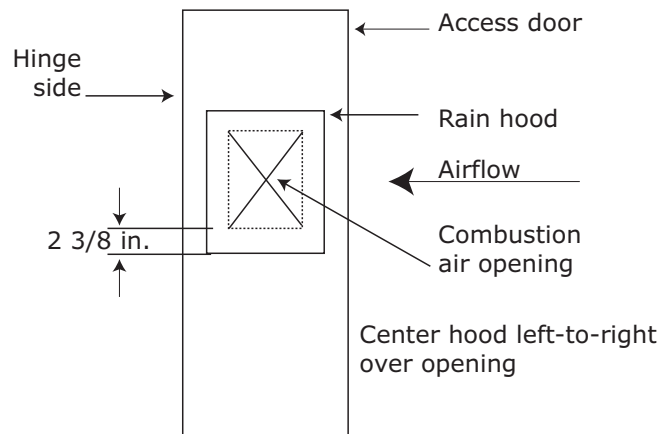

Installing Flue Stack for Hurricane Applications

Figure 9. Flue stack installation for hurricane applications

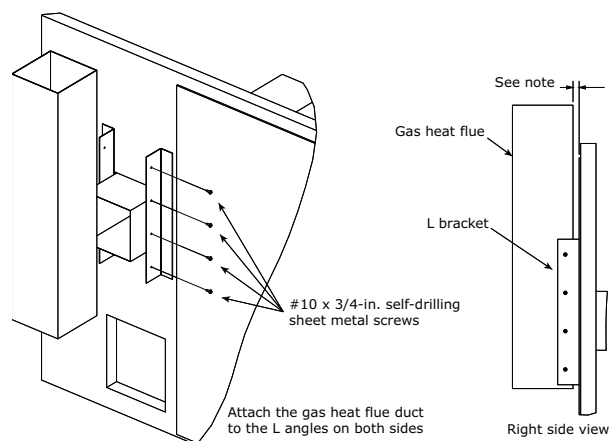

Note:
When installing flue, leave enough clearance to avoid roof's edge and anything above the roof.

Duct Connections

All duct connections to the gas heat section should be installed in accordance with the standards of the National Fire Protection Association (NFPA) and the Sheet Metal and Air Conditioning Contractors National Association, Inc. (SMACNA).

Combustion Air Duct

- Outdoor units with internal vestibules have a rain hood that requires field mounting.
- Outdoor units with external vestibules do not have a rain hood. Combustion air enters through openings in the bottom of the vestibule.
- All indoor units ship with a screened opening on the combustion air inlet.

If combustion air is to be ducted to the gas heat vestibule, the unit's capacity must be derated to account for the resistance in the air duct. For every 0.14 inches wg of duct resistance, unit capacity (MBh output) will reduce by five percent.

If combustion air is ducted to the vestibule air intake, the perforated inlet panel on the side of the vestibule needs to be cut out before ducting to the unit.

If combustion air is ducted to the vestibule, it is strongly recommended that an experienced gas heat technician check the system and emission levels in the exhaust flue at start up. Carbon dioxide should be between 8.2 and 9.4 percent. This corresponds to the allowable range of excess air needed for combustion. The additional static pressure of the inlet air duct may change the fuel-air ratio slightly necessitating system adjustment.

Separated combustion can be a desirable option, but will require more field-installation time and material. The burner fans are not sized to handle any static in the combustion air stream. A booster fan will likely be required to overcome combustion air duct static.

Combustion air cannot be ducted directly to the combustion air fan. The airflow through the vestibule is needed to keep the temperatures in the vestibule down.

Duct Transitions

When the gas heat section is the last section of the air handler, and duct transitions should be smooth and uniform from all sides. Follow recommendations for duct transitions from SMACNA.

Fasten the ductwork directly to the ductwork opening. When using lined ductwork, the insulation should not obstruct the discharge opening.

Airflow Direction

The airflow direction through the gas heater is important because it prevents localized "hot spots" on the heat exchanger. Airflow direction labels denoting correct

airflow direction through the gas heat section are provided on the burner side of the heating section. See Figure 10.

Figure 10. Airflow direction label

Performance Climate Changer™ Air Handler

Order No.	A5K703A B/M A
Serial No.	K01K12345
Unit Model No.	CSAA006UAC00
Tag ID	AHU-1
Build Section	2 of 2

GAS HEATSECTION			
NATURAL GAS		MAX	MIN
INPUT – MBH/HR		375	125
OUTPUT – MBH/HR		300	100
GAS INLET PRESS – IN. W.C.		14	7
MANIFOLD PRESS – IN. W.C.		3.7	0.41
TEMPERATURE RISE – F		91	30
EXT STATIC PRESS – IN. W.C.		2.5	

INPUT V/HZ/PH	115/60/3	MCA	11.4	MOP	15.0
BURNER V/HZ/PH	120/60/1	FLA	4.3	HP	0.25
CONTRCT V/HZ/PH	120/60/1	A	6.0		

CLEARANCES TO COMPBUSTIBLE MATERIAL:

FLUE: 6 inches

CABINET: 0 inches

DUCT: 2 inches for 3 feet; 0 inches thereafter

Note: Reference burner nameplate for recommended gas manifold pressure at startup.

Manufactured under one or more of the following patent numbers:
 5396782, 5674125, 6237354, 6973795, 7017356, 7150314, 7178355, 7340906, 7389646, 7526903, 7685834.

Trane
www.trane.com
Made in USA

Airflow from the supply fan should enter on the drum (or primary) side of the heat exchanger (Figure 11) and exit on the tube (or secondary) side (Figure 12).

Figure 11. Entering airside (drum or primary) of gas heat section

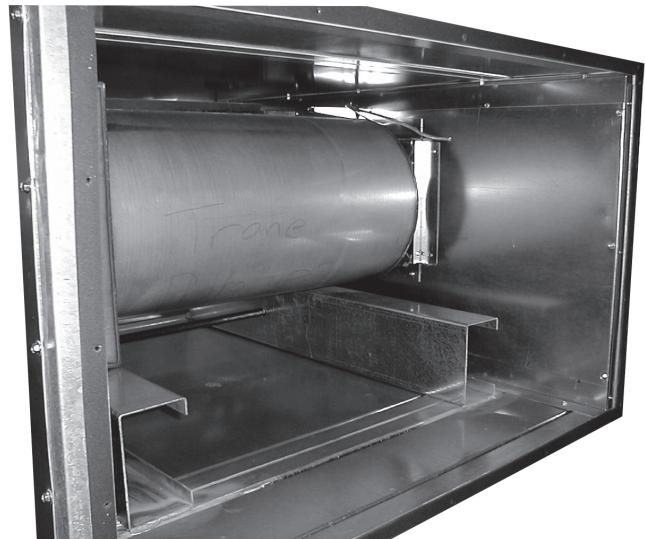
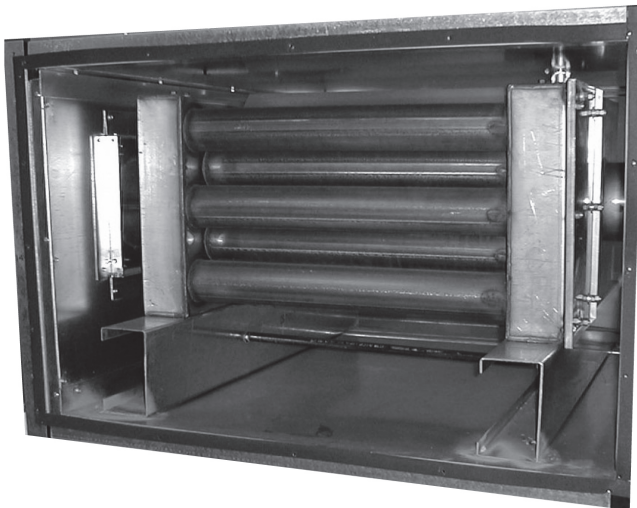

Figure 12. Leaving air side (tube or secondary) of gas heat section



Piping

⚠ WARNING

Hazard of Explosion and Deadly Gases!

Never solder, braze or weld on refrigerant lines or any unit components that are above atmospheric pressure or where refrigerant may be present. Always remove refrigerant by following the guidelines established by the EPA Federal Clean Air Act or other state or local codes as appropriate. After refrigerant removal, use dry nitrogen to bring system back to atmospheric pressure before opening system for repairs. Mixtures of refrigerants and air under pressure may become combustible in the presence of an ignition source leading to an explosion. Excessive heat from soldering, brazing or welding with refrigerant vapors present can form highly toxic gases and extremely corrosive acids. Failure to follow all proper safe refrigerant handling practices could result in death or serious injury.

Gas Piping

Note: Installation must conform with the American National Standard Z223.1 (NFPA 54), the National Fuel Gas Code, latest edition, in the absence of local codes.

- Gas piping should always be done in accordance with local codes.
- Tighten all joints securely.
- Pipe unions should be a “ground joint” type to prevent leakage.
- Provide adequate support for field-installed piping to avoid placing stress on the gas train and controls.

- Run takeoff lines from the side or top of the main gas line to prevent moisture from being drawn into the gas train of the unit.
- Provide a drip leg in the field-installed piping, installing it near the unit.
- Refer to [Figure 13, p. 17](#) and [Figure 14, p. 18](#) for acceptable piping penetration locations.

Figure 13. Gas heat internal piping penetration location

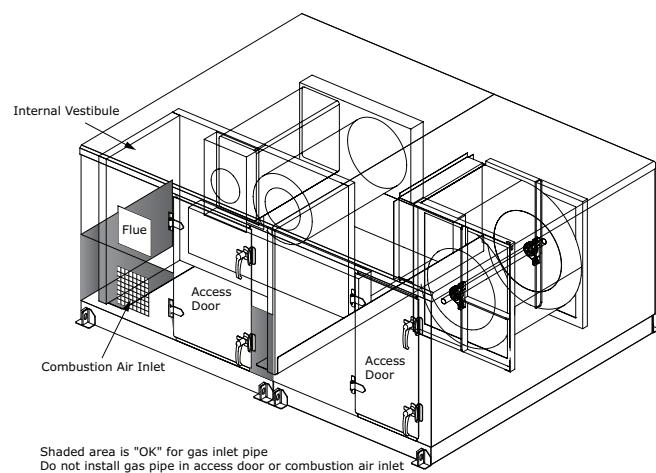
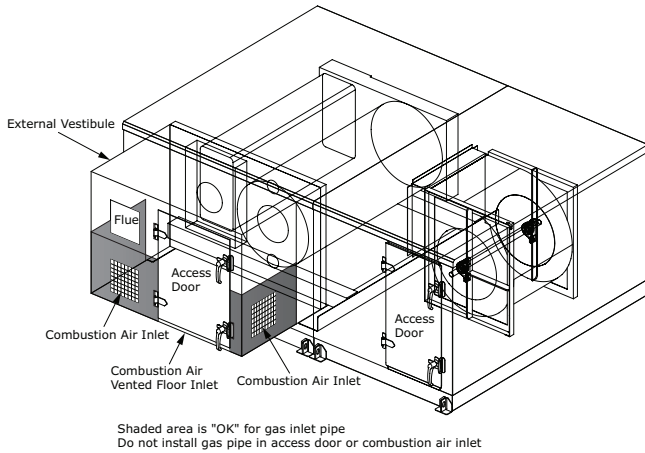

Figure 14. Gas heat external piping penetration location



- To assure sufficient gas pressure at the unit, use appropriately sized gas pipe for unit capacity. Refer to the National Fuel Gas Code for pipe sizing information.
- Select an appropriately sized gas pressure regulator to assure the required gas supply pressure is maintained at the unit.
- Required gas pressure to the gas train is 7 to 14 inches wc (0.25 to 0.5 psig) for units through 2400 MBh. Note that a minimum of 9 inches wc (0.32 psig) is required for 1250-2000 MBh heaters with 10:1 turndown capability. For all size units, do not exceed 14 inches wc (0.5 psig) inlet gas pressure.
- Gas pressure and volume must be maintained and stable at high fire.
- If the gas pressure regulator serves more than one heating unit, it must be sized appropriately to ensure that the inlet gas pressure at each unit is 7 to 14 inches wc while all burners are firing. Nine inches wc is required for 1250 to 2000 10:1 turndown heaters. Gas pressure must not exceed 14 inches wc when all units are off.
- Check the gas supply pressure before making the final connection to the unit. If the gas pressure is too high, damage to the gas valve could occur.

Proper Gas Pressure

NOTICE

Excessive Gas Pressure!

The gas pressure at the inlet to the gas train must not exceed 14 in. wc. A properly sized gas regulator that provides a maximum of 14 in wc. of gas pressure, must be supplied in the gas inlet line to unit. Failure to maintain proper gas pressure could result in damage to the gas train components.

Table 6. Gas supply line connection sizes

Gas Output (MBh)	200-320 (Midco Burner)	200-560 (Non-Midco Burner)	700-1000	1250-1750	2000-2400
Connection Size (NPT)	3/4 in.	1 in.	1 1/4 in.	1 1/2 in.	2 in.

Note: If gas output is between 200 and 320 MBh, confirm burner manufacturer before sizing gas supply line.

Heat Exchanger Condensate Piping

Condensate usually does not form in the heat exchanger during normal heating operation. However, if the unit operates for extended periods of time at very low fire, or if the air handler serves as a cooling unit also, condensate can form in the heat exchanger and should be removed.

All units are equipped with a condensate drain and drain valve. The condensate drain is on the same side as the gas train located inside the piping vestibule. A p-trap is required for the condensate drain line. Consult local plumbing codes for disposal of the condensate as it may be a slightly acidic solution.

Use [Figure 15](#) as a guideline for p-trap construction.

The use of a tee-fitting at the connection to the condensate outlet is recommended. This allows for priming and cleaning the trap. If a tee-fitting is used, be sure to furnish

a plug or cap for the clean out opening. Be sure to replace the plug after priming or cleaning the trap.

Figure 15. Heat exchanger condensate piping

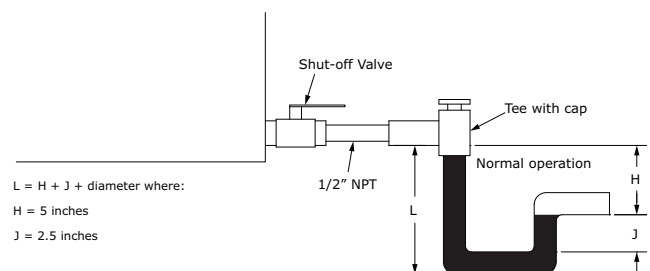

Wiring

⚠ WARNING

Proper Field Wiring and Grounding Required!

All field wiring **MUST** be performed by qualified personnel. Improperly installed and grounded field wiring poses **FIRE** and **ELECTROCUTION** hazards. To avoid these hazards, you **MUST** follow requirements for field wiring installation and grounding as described in **NEC** and your local/state electrical codes. Failure to follow code could result in death or serious injury.

⚠ WARNING

Hazardous Voltage!

Disconnect all electric power, including remote disconnects before servicing. Follow proper lockout/tagout procedures to ensure the power can not be inadvertently energized. Failure to disconnect power before servicing could result in death or serious injury.

NOTICE

Use Copper Conductors Only!

Unit terminals are not designed to accept other types of conductors. Failure to use copper conductors could result in equipment damage.

Wiring Checklist

- All field wiring must be in accordance with the National Electric Code and state and local requirements.
- All wiring (including low-voltage wiring) must be copper conductors only with the insulation rated for 600 volts.
- Refer to the nameplate located on the gas heater section for the proper Input Voltage, Minimum Circuit Ampacity (MCA) and Maximum Overcurrent Protection (MOP) requirements for proper electrical installation.
- Input voltage must be within +/- 10 percent of specified value.
- Ground the supply power in the junction box to the ground lead provided.
- Do not route any wires through the heat exchanger section unless the insulation is rated for 600°F or higher. Radiant heat from the heat exchanger will damage wire insulation that is unsuitable for high temperatures.
- See [Table 7](#) for power supply requirements.

Note: Factory wiring routed through the heated part of the cabinet has insulation rated for 600°F.

High-Voltage Wiring

Wiring Entrance Locations

Indoor air handlers can accept conduit penetrations on any side of the piping vestibule. For outdoor air handlers, the recommended conduit entrance into the gas heat section is through the floor of the piping vestibule.

Terminate conduits on the power junction box or gas heater control panel as appropriate.

Table 7. Power supply requirements

3:1 and 10:1 Burner Turndown Units			
Gas Output (MBh)	200-1000	1250-2000	2000 ³
Voltage/Ph	115-575/1	208-575/3	208/230/460/575/3
Minimum Circuit Ampacity (MCA)	less than 15	less than 15 ¹	19.71/17.9/9.0/7.2
Maximum Overcurrent Protection (MOP)	15	15 ²	25/25/15/15
Note: ¹ All except the 2000 MBh output, 208 volt, 3 phase unit. This unit will have a marked MCA of 16.1 ² All except the 2000 MBh output, 208 and 230 volt, 3 phase units. These units have a marked MOP of 20 ³ 2000 MBh with optional 3 hp exhaust motor required for long horizontal flue vents			
20:1 Burner Turndown Units			
Gas Output (MBh)	1250-1750	2000	2400
Voltage/Ph	208-575/3	208/230/460/575/3	208/230/460/575/3
Minimum Circuit Ampacity (MCA)	less than 15	17.3/16.0/8.0/6.4	20.9/19.0/9.5/7.6
Maximum Overcurrent Protection (MOP)	15	20/20/15/15	25/25/15/15
Note: The MCA and MOP for the 2000 MBh with optional 3 hp exhaust motor will be the same as 2400 MBh.			



Wiring

Gas Heaters with 200–1000 MBh Output

Single-phase 120, 208, 230, 460 or 575 volt power is required to operate the heater controls or power the transformer (TRANS1), if provided.

Single-phase power for 208, 230 460 and 575 voltage is provided for the gas heat off two legs of the three-phase supply to the air-handling unit. A transformer in the piping vestibule is provided to step down the voltage required for gas heat.

Gas Heaters with 1250–2400 MBh Output

Three-phase 208, 230, 460 or 575 volt power is required to operate the exhaust fan and power the transformer (TRANS1).

Low-Voltage Wiring

NOTICE

Equipment Damage!

The gas heat system will not operate without a supply fan providing airflow. Operating the gas heat system without a supply fan could result in damage to equipment or property.

The gas heat control system requires a binary signal for on/off control. Provide an interlock in the start-stop signal circuit with the air handler supply fan. This interlock must insure the start-stop signal is interrupted to the gas heat system if the supply fan is shut off. The gas heat system must not operate without the supply fan providing airflow.

The control system also requires a 2 to 10 Vdc analog signal for modulation where 10 Vdc is a signal for full heat. A 4 to 20 mA interface module is available.

Figure 17. Natural gas 360-1000 MBh - 3:1 and 10:1 turndown and propane 200-1000 MBh

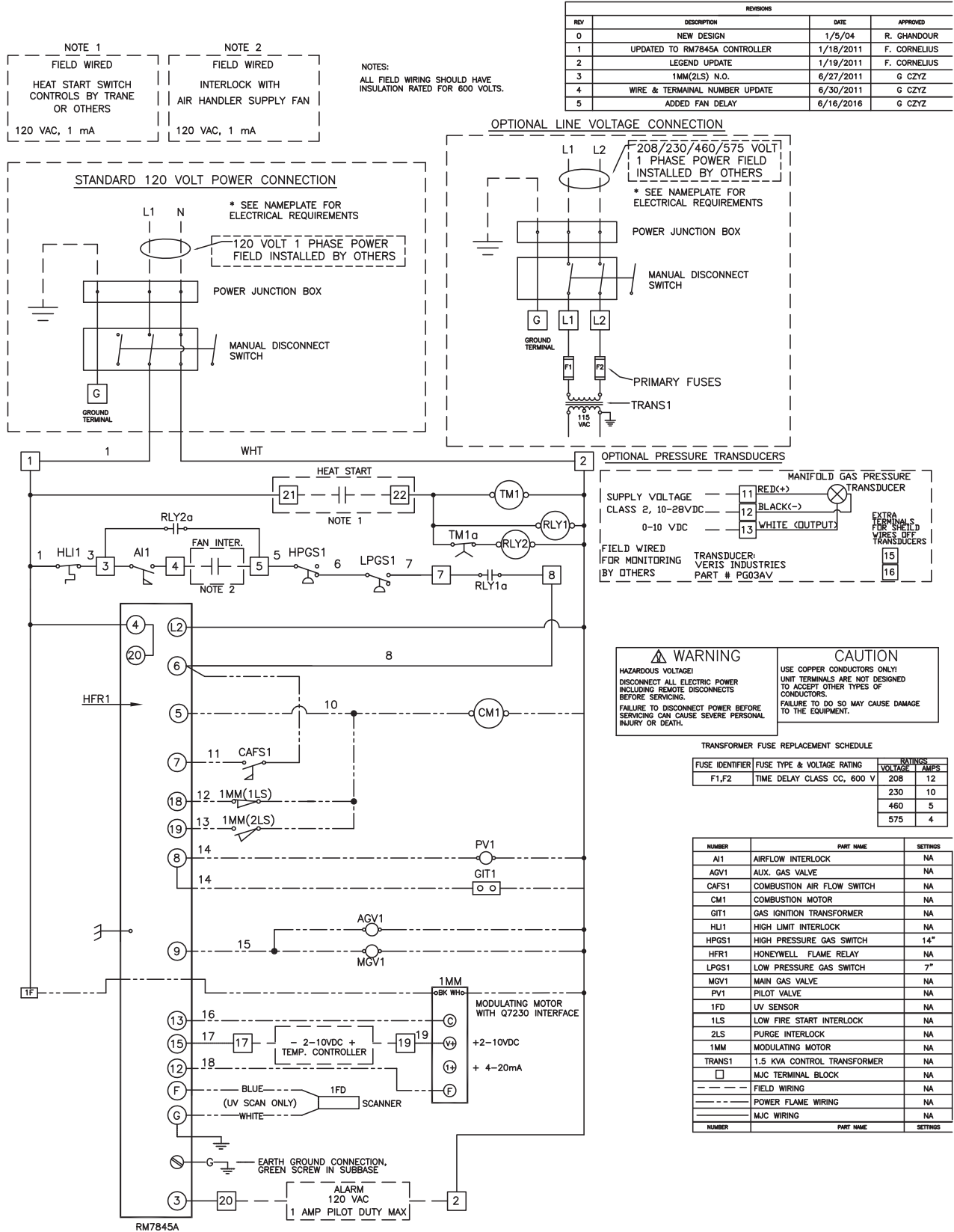

Figure 18. Single phase natural gas and propane 1250-2000 MBh - 3:1 and 10:1 turndown

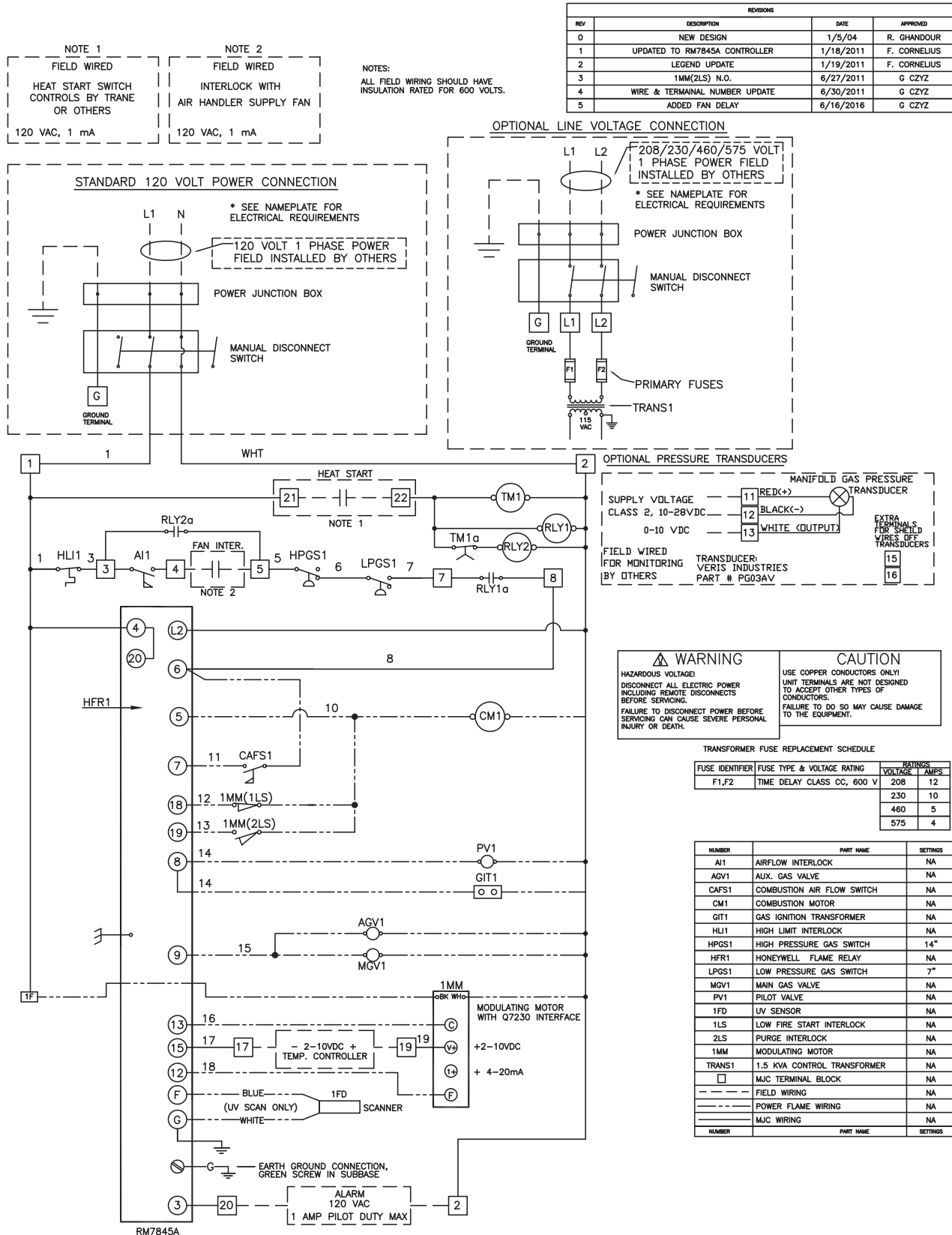
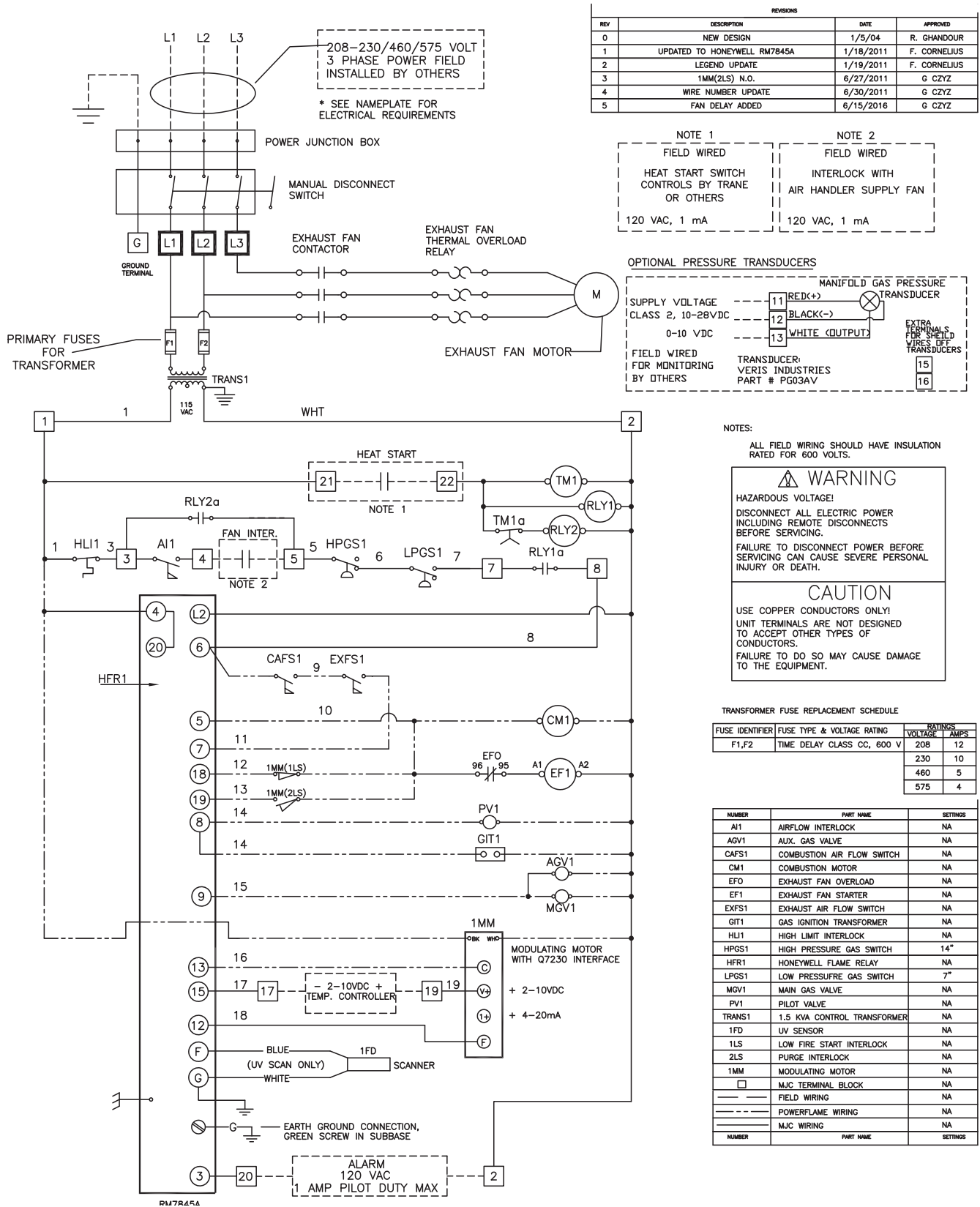

Figure 19. 3 Phase propane and natural gas 1250-2000 MBh - 3:1 and 10:1 turndown with power exhaust



REVISIONS			
REV	DESCRIPTION	DATE	APPROVED
0	NEW DESIGN	1/5/04	R. GHANDOUR
1	UPDATED TO HONEYWELL RM7845A	1/18/2011	F. CORNELIUS
2	LEGEND UPDATE	1/19/2011	F. CORNELIUS
3	1MM(2LS) N.O.	6/27/2011	G CZYZ
4	WIRE NUMBER UPDATE	6/30/2011	G CZYZ
5	FAN DELAY ADDED	6/15/2016	G CZYZ

NOTE 1
FIELD WIRED
HEAT START SWITCH CONTROLS BY TRANE OR OTHERS
120 VAC, 1 mA

NOTE 2
FIELD WIRED
INTERLOCK WITH AIR HANDLER SUPPLY FAN
120 VAC, 1 mA

OPTIONAL PRESSURE TRANSDUCERS

SUPPLY VOLTAGE CLASS 2, 10-28VDC
0-10 VDC

FIELD WIRED FOR MONITORING BY OTHERS

MANIFOLD GAS PRESSURE TRANSDUCER
EXTRA TERMINALS FOR SHIELD WIRES OFF TRANSDUCERS

TRANSDUCER: VERIS INDUSTRIES PART # PG03AV

NOTES:
ALL FIELD WIRING SHOULD HAVE INSULATION RATED FOR 600 VOLTS.

WARNING
HAZARDOUS VOLTAGE!
DISCONNECT ALL ELECTRIC POWER INCLUDING REMOTE DISCONNECTS BEFORE SERVICING.
FAILURE TO DISCONNECT POWER BEFORE SERVICING CAN CAUSE SEVERE PERSONAL INJURY OR DEATH.

CAUTION
USE COPPER CONDUCTORS ONLY!
UNIT TERMINALS ARE NOT DESIGNED TO ACCEPT OTHER TYPES OF CONDUCTORS.
FAILURE TO DO SO MAY CAUSE DAMAGE TO THE EQUIPMENT.

TRANSFORMER FUSE REPLACEMENT SCHEDULE

FUSE IDENTIFIER	FUSE TYPE & VOLTAGE RATING	RATINGS	
		VOLTAGE	AMPS
F1,F2	TIME DELAY CLASS CC, 600 V	208	12
		230	10
		460	5
		575	4

NUMBER	PART NAME	SETTINGS
A11	AIRFLOW INTERLOCK	NA
AGV1	AUX. GAS VALVE	NA
CAFS1	COMBUSTION AIR FLOW SWITCH	NA
CM1	COMBUSTION MOTOR	NA
EFO	EXHAUST FAN OVERLOAD	NA
EF1	EXHAUST FAN STARTER	NA
EXFS1	EXHAUST AIR FLOW SWITCH	NA
GIT1	GAS IGNITION TRANSFORMER	NA
HLI1	HIGH LIMIT INTERLOCK	NA
HPGS1	HIGH PRESSURE GAS SWITCH	14"
HFR1	HONEYWELL FLAME RELAY	NA
LPGS1	LOW PRESSURE GAS SWITCH	7"
MGV1	MAIN GAS VALVE	NA
PV1	PILOT VALVE	NA
TRANS1	1.5 KVA CONTROL TRANSFORMER	NA
1FD	UV SENSOR	NA
1LS	LOW FIRE START INTERLOCK	NA
2LS	PURGE INTERLOCK	NA
1MM	MODULATING MOTOR	NA
MJC	MJC TERMINAL BLOCK	NA
---	FIELD WIRING	NA
---	POWERFLAME WIRING	NA
---	MJC WIRING	NA

Figure 20. Natural gas and propane 1250-2400 MBh - 20:1 turndown

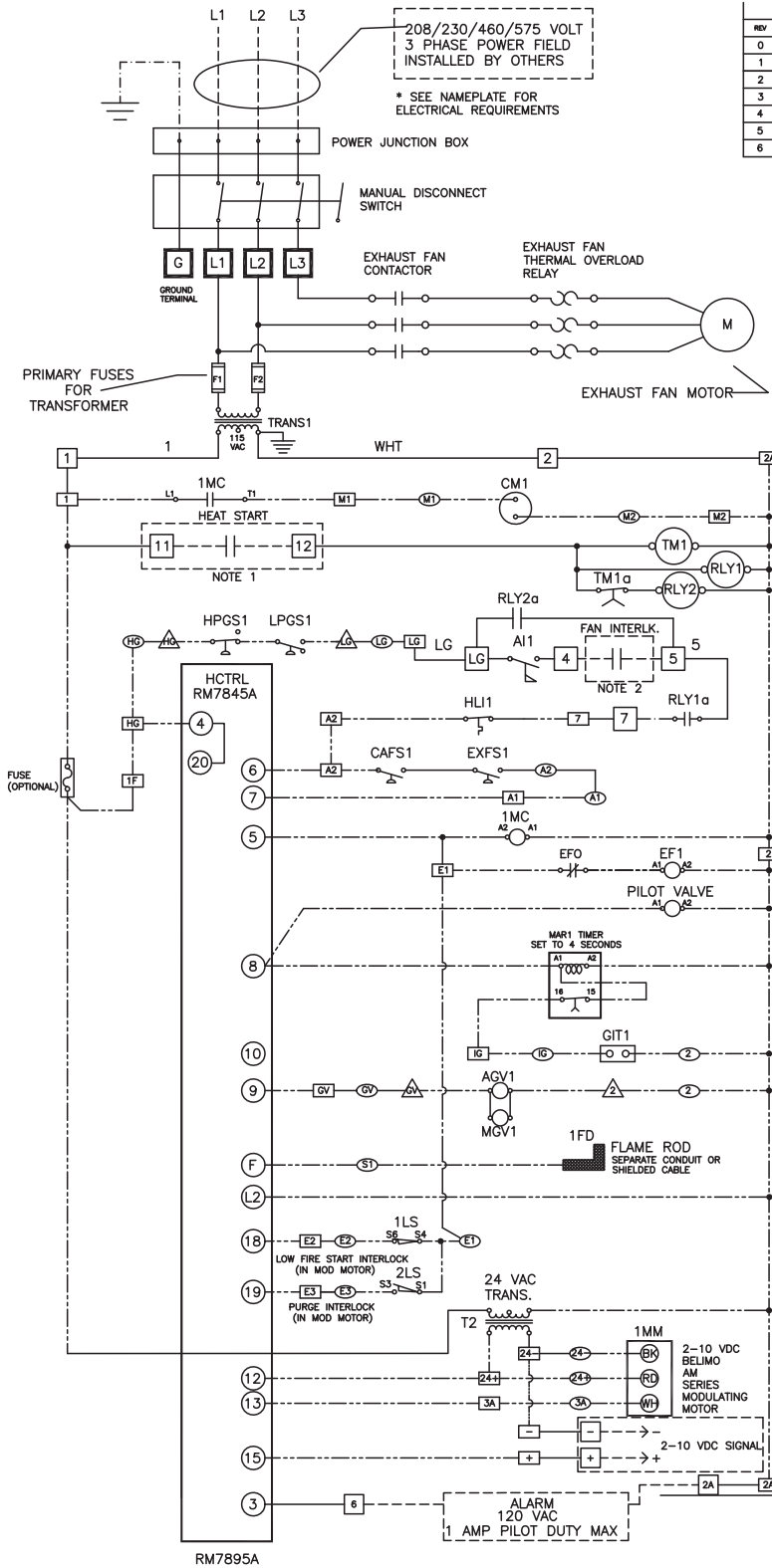

REVISIONS			
REV	DESCRIPTION	DATE	APPROVED
0	NEW DESIGN	3/24/04	R. GHANDOUR
1	MODIFIED TO REFLECT CHANGES IN POWERFLAME DWG	10/3/05	R. GHANDOUR
2	MODIFIED TO REFLECT PILOT VALVE	8/18/08	G CZYZ
3	REMOVED JUMPER 8 TO 9	9/2/2010	G CZYZ
4	UPDATED TO RM7845A CONTROLLER	1/18/2011	F CORNELIUS
5	LEGEND UPDATE	1/19/2011	F CORNELIUS
6	FAN DELAY ADDED	6/16/2016	G CZYZ

NOTE 1
FIELD WIRE
HEAT START SWITCH
CONTROLS BY TRANE
OR OTHERS
120 VAC, 1 mA

NOTE 2
FIELD WIRE
INTERLOCK WITH
AIR HANDLER SUPPLY FAN
120 VAC, 1 mA

GENERAL NOTES:
1 ALL FIELD WIRING SHOULD HAVE INSULATION RATED FOR 600 VOLTS AND 75 DEG. C COPPER.

WARNING
HAZARDOUS VOLTAGE!
DISCONNECT ALL ELECTRIC POWER INCLUDING REMOTE DISCONNECTS BEFORE SERVICING.
FAILURE TO DISCONNECT POWER BEFORE SERVICING CAN CAUSE SEVERE PERSONAL INJURY OR DEATH.

CAUTION
USE COPPER CONDUCTORS ONLY!
UNIT TERMINALS ARE NOT DESIGNED TO ACCEPT OTHER TYPES OF CONDUCTORS.
FAILURE TO DO SO MAY CAUSE DAMAGE TO THE EQUIPMENT.

OPTIONAL PRESSURE TRANSDUCERS
MANIFOLD GAS PRESSURE TRANSDUCER
SUPPLY VOLTAGE CLASS 2, 10-28VDC
0-10 VDC
FIELD WIRE FOR MONITORING BY OTHERS
TRANSUCER: VERIS INDUSTRIES PART # PG93AV
EXTRA FIELD WIRE FOR PRESSURE TRANSDUCERS

TRANSFORMER FUSE REPLACEMENT SCHEDULE			
FUSE LD	FUSE TYPE & VOLTAGE RATING	RATINGS	
		VOLTAGE	AMPS
F1,F2	TIME DELAY CLASS CC, 600 V	1.5 kVA	2.0 kVA
		208	12 15
		230	10 12
		460	5 7
		575	4 5.6

NUMBER	PART NAME	SETTINGS
1LS	LOW FIRE START INTERLOCK	NA
2LS	PURGE INTERLOCK	NA
1MC	BURNER MOTOR CONTACTOR	NA
1MM	MODULATING MOTOR	NA
A1	AIRFLOW INTERLOCK	NA
AGV1	AUX. GAS VALVE	NA
CAFS1	COMBUSTION AIR FLOW SWITCH	14"
CM1	BURNER MOTOR	NA
EFO	EXHAUST FAN OVERLOAD	NA
EF1	EXHAUST FAN STARTER	NA
EXFS1	EXHAUST AIR FLOW SWITCH	NA
GIT1	GAS IGNITION TRANSFORMER	NA
HCTRL	HONEYWELL RM7845A CONTROLLER	NA
HPCS1	HIGH PRESSURE GAS SWITCH	14"
HLJ1	HIGH LIMIT INTERLOCK	180°F
LPGS1	LOW PRESSURE GAS SWITCH	7"
MAR1	ADJUSTABLE TIMER	4 SEC
MGV1	MAIN GAS VALVE	NA
TRANS1	1.5 OR 2.0 KVA CONTROL TRANSFORMER	NA
□	MJC TERMINAL BLOCK (TB)	NA
○	POWERFLAME REMOTE TB	NA
○	POWERFLAME BURNER TB	NA
△	POWERFLAME GAS TRAIN JUNCTION BOX TB	NA
---	FIELD WIRING	NA
---	POWERFLAME WIRING	NA
---	MJC WIRING	NA

Start Up

⚠ WARNING

Hazardous Gases and Flammable Vapors!

Exposure to hazardous gases from fuel substances have been shown to cause cancer, birth defects or other reproductive harm. Improper installation, adjustment, alteration, service or use of this product could cause flammable mixtures or lead to excessive carbon monoxide. To avoid hazardous gases and flammable vapors follow proper installation and set up of this product and all warnings as provided in this manual. Failure to follow all instructions could result in death or serious injury.

⚠ WARNING

Hazardous Voltage!

Disconnect all electric power, including remote disconnects before servicing. Follow proper lockout/tagout procedures to ensure the power can not be inadvertently energized. Failure to disconnect power before servicing could result in death or serious injury.

⚠ WARNING

Hazard of Explosion!

Installations at altitudes of 3,000 feet above sea level or higher may require adjustment of the air-fuel linkage for proper combustion. Linkage and air-fuel adjustment should only be done by an experienced, qualified gas heat technician. Failure to follow these recommendations could result in death or serious injury or equipment or property-only damage.

Gas heat sections have been run-tested in the factory to assure proper operation and ease of startup. The actuator linkages controlling the air-fuel mixture are preset for optimum efficiency and performance, but jobsite conditions for gas pressure, volume, and quality will require you to fine tune the system in the field.

Thoroughly review all service literature before startup and servicing. The sequence of operation and all details of the flame-safeguard control system can be found in the burner equipment literature. The technical bulletins cover the individual components of the heating system. This literature ships inside the piping vestibule of the gas heat section.

Pre-Startup Checklist

Note: The procedures discussed in this section should be done by qualified technicians who are experienced with gas heating equipment.

- Close all manual gas valves.

- Move the manual disconnect switch in the vestibule to the OFF position.
- Check the air shutter and modulating gas valve linkages for tightness.
- Air shutter may need adjustment when setting up with analyzer.
- Attach a manometer to the tee in the pilot gas line (if optional gauge or sensor is not selected) in the burner vestibule at the inlet end of the gas train, upstream of the automatic gas valve/regulator. This checks incoming gas pressure and should measure 7 to 14 inches w.g. (Exception: 1250 through 2000 MBh and 10:1 turndown require 9 to 14 in. w.g.)
- Attach another manometer to the burner manifold (if optional gauge or sensor is not selected) to check the burner manifold pressure (when the unit is operational). (Typical pressure should be between 2.5 inches and 3 inches w.g.)
- Attach a third manometer to the pilot gas line to check the pilot gas pressure (when the unit is operational).

Figure 21. Control panel for the JR and Midco burner on 200-1000 MBh (3:1 and 10:1 turndown) units

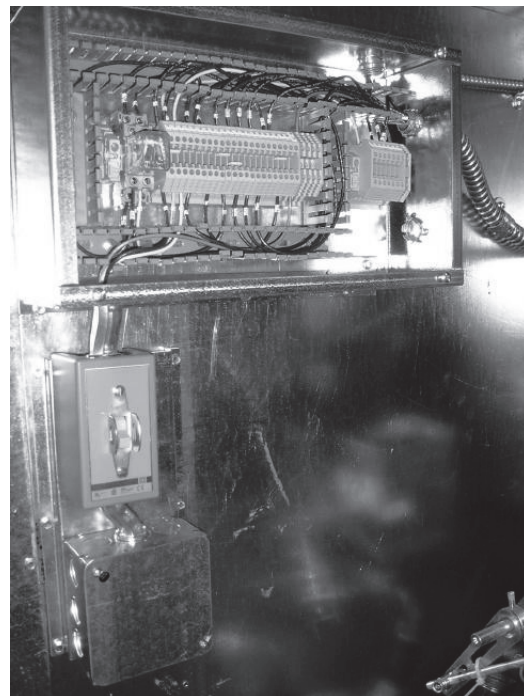
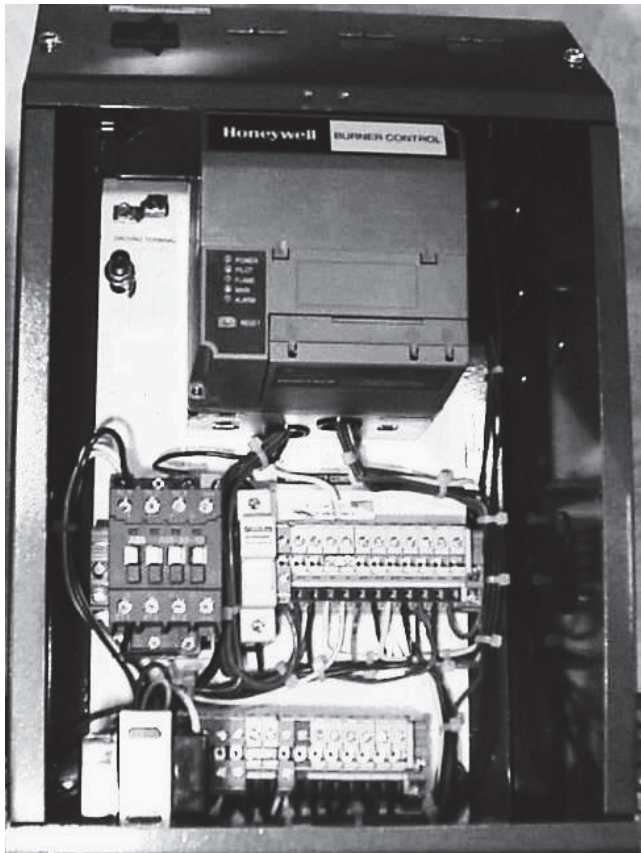

Figure 22. Control panel for the FDM burner on 1250-2400 MBh (20:1 turndown) units



Unit Operation

⚠ WARNING

Live Electrical Components!

During installation, testing, servicing and troubleshooting of this product, it may be necessary to work with live electrical components. Have a qualified licensed electrician or other individual who has been properly trained in handling live electrical components perform these tasks. Failure to follow all electrical safety precautions when exposed to live electrical components could result in death or serious injury.

1. Remove any debris from combustion air inlets and/or hoods. Note that some combustion air inlets are located on the floor panel of the piping vestibule. Insure the openings are not blocked. (If it is an outdoor unit, make sure the flue was removed from inside the unit and is installed properly.)
2. Connect the interlock with the air handling supply fan terminals in the gas heat terminal box with the air handling control system. If jumpers are used in the gas heat control panel to set up unit, ensure they are

removed and the correct air handling control system is connected.

3. Measure the gas pressure at the tee in the pilot gas line (inlet gas pressure). The inlet gas pressure should not exceed 14 in. w.g. Adjust the gas pressure, if necessary.
4. Open the first manual gas valve (inlet) in the burner vestibule.
5. Open the manual gas valve in the pilot gas line and bleed the air from the line. (Do not open the second manual gas valve to the manifold.)
6. Move the manual disconnect switch in the heater vestibule to the ON position.
7. If the building control system is calling for heat, the system should energize. If jumpers are used in the gas heat control panel to close between terminals for startup, ensure they are removed and unit controls controlling the "call for Heat" are attached properly after startup.
8. The unit control system should energize supply fan in less than 60 seconds after call for heat signal is given (if not already running). Ensure supply fan airflow is made before safety circuitry de-energized burner assembly. The following safety/limit contracts should be closed:
 - HLI1: high-temperature limit
 - AI1: airflow interlock (air handling fan should either be running or started 60 seconds after call for heat)
 - HPGS1: high-pressure gas switch
 - LPGS1: low-pressure gas switch

Pre-Purge and Pilot Ignition

(3:1, 10:1 Turndown, 200-2000 MBh)

1. The burner will be going through a purge sequence. The combustion air blower should run for approximately 90 seconds to evacuate the heat exchanger of any combustible gases before the ignition sequence. This pre-purge cycle is initiated before every startup.
2. With the pre-purge cycle complete, the ignition transformer and pilot solenoid should be energized, allowing gas to flow to the pilot burner. The pilot should light immediately. The pilot flame gas pressure should be 2.5 inches w.g.
3. If the pilot does not light within 10 seconds, the flame relay/rod should shut down the system. If the pilot does not light, press the Reset button to clear the fault and repeat the procedure outline in the startup.
4. Cycle the pilot on and off several times to ensure its reliability.
5. Turn the manual disconnect switch in the gas heat control panel to the Off position and proceed to the Main Burner Ignition.



Start Up

Main Burner Ignition

(3:1, 10:1 Turndown, 200-2000 MBh)

1. With the manual disconnect switch in the gas heat control panel in the Off position, open the second manual gas valve located downstream of the modulating gas valve.
2. Turn the manual disconnect switch to the On position. After the pre-purge and pilot cycle, the main gas valve will energize and the main burner will light.
3. The flame can be observed through the larger sight glass under the burner (or opposite side of drum on size 200). The normal flame color is blue with yellow tips; abnormal color is yellow. Yellow indicates a need for adjustments by a qualified technician.
4. Check the flame-signal strength from the ultra-violet sensor. A 0 to 15 Vdc, 10K ohm (minimum) voltmeter is required.
5. Insert the positive probe of the voltmeter into the positive (+) flame-signal test point on the flame relay cover.
6. Connect the negative probe to the negative (-) test point on the flame relay cover. [Table 8](#) shows the desired signal strengths.
7. Allow the burner to ramp up to full fire.

Table 8. Signal strengths

Signal Strength	Ultra-Violet Sensor
Good	5.0–11.0 Vdc
Marginal	1.7–5.0 Vdc
Inadequate	0.0–1.7 Vdc

Pre-Purge and Main Flame Ignition

(20:1 Turndown, 1250-2400 MBh)

With the manual gas cocks closed move the manual disconnect switch in the heater vestibule to the ON position. The system should energize, and the combustion blower motor should start, indicating that all of the safety/limit contacts are closed:

- HLL1: high-temperature limit
- AL1: airflow interlock
- HPGS1: high-pressure gas switch
- LPGS1: low-pressure gas switch

The combustion airflow switch (CAFS1) should close, starting the purge timer, the green power light should illuminate on the flame-relay panel, and the prepurge cycle should begin. The combustion air blower should run for approximately 90 seconds to evacuate the heat exchanger of any combustible gases before the ignition sequence. This prepurge cycle is initiated before every startup.

At the end of the purge cycle, the ignition transformer and automatic gas valves will energize. With the manual gas cocks closed, the burner should go into a safety lockout condition. The flame safeguard will have to be reset manually. Turn the manual disconnect switch in the control panel to the OFF position.

Note: *Prior to opening the manual gas cock make certain the modulating gas linkage is set to operate in all positions without binding.*

1. Turn the manual disconnect switch in the control panel to the ON position. After the prepurge sequence is complete the ignition transformer will energize providing ignition spark and the main automatic gas valves will open. With the ignition spark energized and the automatic gas valve open, slowly open the manual gas shut off cocks. Flame should be established. (Make sure the modulating gas valve is adequately open).
2. At initial start up, air may be trapped in the gas lines so more than one attempt to light off may be required. Do not allow unburned gas to accumulate in the combustion chamber.
3. Once flame is established run the mod motor to position the modulating gas valve wide open.
4. The amber Main Flame light should illuminate on the flame relay panel after the ultra-violet flame sensor has detected the main flame. The flame can be observed through the larger sight glass under the burner. Normal flame color is blue with yellow tips; abnormal color is yellow, indicating a need for adjustments by a qualified technician. Note that smaller sized heaters have the sight glass on the side opposite the piping connection side.
5. Check the flame-signal strength from the flame rod. A 0 to 15 Vdc, 1 megohm/volt (minimum) meter is required.
6. Insert the positive probe of the voltmeter into the positive (+) flame-signal test point on the flame relay cover.
7. Connect the negative probe to the negative (-) test point on the flame relay cover. Flame signal strength should be a steady dc voltage between 1.25 and 5.0 volts.
8. Allow the burner to ramp up to full fire.

Final Check Out

1. Check the gas pressure at the burner manifold. It should be the same pressure that is indicated on the Manifold Pressure at Max. Input nameplate at *full fire*. Refer to the burner nameplate for this value.
2. Adjust the gas pressure at the regulator by removing the dust cap on the main gas valve/regulator and turning the adjusting screw. Turn the adjusting screw clockwise to increase the gas pressure; turn the adjusting screw counter-clockwise to decrease the gas pressure. If the pressure cannot be maintained at full fire at the setting shown on the nameplate and the regulator is adjusted fully open, contact your local gas utility.
3. Using a gas analyzer, check the emissions in the exhaust gas. Acceptable values are:
 - a. Carbon monoxide (CO)—400 ppm or less corrected to 12 percent carbon dioxide.
 - b. Efficiency—75 percent or higher
 - c. Oxygen—8 to 12 percent
 - d. Carbon dioxide - 8.2 to 9.4 percent
3. **3:1 and 10:1 turndown, 200-2000 MBh:** The pilot light ignites, and the pilot light on the flame-relay module should illuminate. (The pilot flame can be viewed through the small sight glass on the burner.) The pilot flame will burn for 10 seconds, then the flame light on the flame-relay module should illuminate.
4. **3:1 and 10:1 turndown, 200-2000 MBh:** The main burner ignites, the modulating gas-valve actuator starts to open, and the main light on the flame-relay module should illuminate. Note that it could take as long as 30 seconds for the actuator to fully open.
5. **20:1 turndown, 1250 thru 2400 MBh:** The main burner lights and the main burner light on the flame-relay should illuminate. The modulating gas-valve actuator starts to open, and the main light on the flame-relay module should illuminate. Note that it could take as long as 30 seconds for the actuator to fully open.
6. The gas-valve actuator slowly modulates open or closed in response to the heat load required in the building.
7. Complete the start-up checklist and send a copy as directed to Trane to validate the warranty.

NOTICE

Over Firing Burners!

If fuel and air adjustment linkages were adjusted in the start-up process, insure that the burner is not allowed to over fire. The gas pressure on the manifold must not exceed the gas pressure stated on the Powerflame burner name plate. Over firing operation could result in equipment and property damage.

⚠ WARNING

Hazardous Gases and Flammable Vapors!

Exposure to hazardous gases from fuel substances have been shown to cause cancer, birth defects or other reproductive harm. Improper installation, adjustment, alteration, service or use of this product could cause flammable mixtures or lead to excessive carbon monoxide. To avoid hazardous gases and flammable vapors follow proper installation and set up of this product and all warnings as provided in this manual. Failure to follow all instructions could result in death or serious injury.

The gas heat module/section goes through the following routine every time it is started. The air handler fan must be running, and the Power light on the flame-relay module should be illuminated.

1. A contact closure command (the signal to start) comes from a thermostat or building automation system.
2. The combustion air blower starts and runs for approximately 90 seconds. This 90-second run is a pre-purge cycle to clear the heat exchanger of combustible gases before ignition.

Normal Shutdown

When the system no longer requires heat, the temperature control system opens the heat start contacts. The pilot valve (3:1, 10:1 turndown burners), modulating gas valve (20:1 turndown burners), automatic gas valve/regulator, redundant automatic gas valve, and combustion blower motor immediately de-energize, shutting down the heating system.

The air-handling unit fan should run for a *minimum* of three to ten minutes after heater shutdown to cool the heat exchanger.

Seasonal Startup/Shutdown

Note: *This procedure should be performed by a qualified technician who is experienced in the servicing of gas heating equipment.*

The following recommended procedures for seasonal shutdown and startup are important to maintaining your equipment in proper working order.

Seasonal Shutdown

When heating system is to be shut down for extended period of time:

1. Disconnect the main power to the heating module/section.
2. Open the manual disconnect switch in the control panel.
3. Close all manual valves in the gas line.



Start Up

Seasonal Startup

When heating system is to be started for first time in the season:

1. Disconnect electrical power.
2. If the heat exchanger does not have a p-trap and condensate drain line, connect a hose to the drain valve and drain any accumulated condensate.
3. Check all electrical terminals for tight connections.
4. Open all manual gas valves and ensure that these valves operate freely.
5. Check the air shutter and modulating gas valve linkages for tightness.
6. Clean dust, dirt, and debris from the air shutters on the combustion fan and the air inlet louver.
7. Check the exhaust flue for debris and clean as necessary.
8. Re-connect the power and initiate the startup sequence.



Routine Maintenance

⚠ WARNING

Hazardous Gases and Flammable Vapors!

Exposure to hazardous gases from fuel substances have been shown to cause cancer, birth defects or other reproductive harm. Improper installation, adjustment, alteration, service or use of this product could cause flammable mixtures or lead to excessive carbon monoxide. To avoid hazardous gases and flammable vapors follow proper installation and set up of this product and all warnings as provided in this manual. Failure to follow all instructions could result in death or serious injury.

Heating Mode Maintenance

Table 9. Routine maintenance in heating mode

Task	Frequency	Remarks
Unit startup	Weekly	Listen to and visually inspect the unit during normal startup.
Unit shutdown	Weekly	Listen to and visually inspect the unit during normal shutdown.
Check fuel valves, pilot and main	Weekly	Open limit switches and listen to and visually inspect.
Check combustion safety controls:		
- Flame failure	Weekly	Close manual fuel supply for the pilot and the main fuel valves; check safety shutdown timing and record.
- Flame signal strength	Weekly	Follow procedure to check flame signal strength outlined in "Main Burner Ignition," p. 28.
Drain condensate from heat exchanger	Weekly	This task only needs to be done if the unit runs for extended hours at low fire.
Clean air inlet louver	Monthly	Use brush and vacuum cleaner
Clean combustion air blower and motor	Monthly	Use brush and vacuum cleaner
Clean exhaust flue	Monthly	Use brush and vacuum cleaner
Clean combustion air dampers	Monthly	Use brush and vacuum cleaner
Check combustion air inlets for obstruction. Remove debris.	Monthly	Use brush or vacuum cleaner.
Check gas piping for leaks	Yearly	Use soap bubble solution or equivalent leak tester. ⚠ WARNING: Do <i>not</i> use an open flame to perform a leak test as personal injury or death could occur.

Service Personnel Maintenance

Table 10. Routine maintenance for trained service personnel

Task	Frequency	Remarks
Inspect burner components	Semiannually	Refer to burner and component manufacturer's manuals
Visually inspect safety switches	Semiannually	Inspect airflow sensor lines for obstructions.
		Inspect terminal connections for tightness.
		Inspect switches for fused contacts. Check that settings haven't changed or been tampered with.
Check flue emissions	Annually	Use a combustion analyzer
Check fuel valves, main	Annually	Perform valve leak test per valve manufacturer's instructions
Check safety controls:		
- High limit	Annually	Refer to control manufacturer's instructions
- Airflow		
- Low gas pressure		
- High gas pressure		
- Exhaust fan switch (where applicable)		
Inspect gas pilot assembly	Annually	Remove and clean if applicable



Troubleshooting

⚠ WARNING

Hazardous Service Procedures!

The maintenance and troubleshooting procedures recommended in this manual could result in exposure to electrical, mechanical or other potential safety hazards. Always refer to the safety warnings provided throughout this manual concerning these procedures. Unless specified otherwise, disconnect all electrical power including remote disconnect and discharge all energy storing devices such as capacitors before servicing. Follow proper lockout/tagout procedures to ensure the power can not be inadvertently energized. When necessary to work with live electrical components, have a qualified licensed electrician or other individual who has been trained in handling live electrical components perform these tasks. Failure to follow all of the recommended safety warnings provided, could result in death or serious injury.

⚠ WARNING

Hazardous Gases and Flammable Vapors!

Exposure to hazardous gases from fuel substances have been shown to cause cancer, birth defects or other reproductive harm. Improper installation, adjustment, alteration, service or use of this product could cause flammable mixtures or lead to excessive carbon monoxide. To avoid hazardous gases and flammable vapors follow proper installation and set up of this product and all warnings as provided in this manual. Failure to follow all instructions could result in death or serious injury.

Table 11. Troubleshooting gas heat sections

Symptom	Probable Cause	Recommended Action	
Unit not running, no heat in building.	Loss of power, fuse blown, or circuit breaker tripped	Check the fuse/breaker panel and reset or replace the device. Check the fuses if provided, in gas heat control panel and replace as needed.	
	Manual gas valve closed	Open the gas valve. There may be more than one manual gas valve in the piping system. Be sure to check all valves.	
	Thermostat not calling for heat	Repair or replace the thermostat, if defective. Set thermostat to heating mode.	
	Safety switch tripped		Verify that one of the following safety switches has tripped:
			<ul style="list-style-type: none"> • <i>High Limit.</i> This switch trips due to a high temperature condition in the gas heat section. Allow the air handler fan to run and cool heat exchanger. The switch must be manually reset when the heat exchanger cools.
			<ul style="list-style-type: none"> • <i>Airflow Interlock.</i> This switch trips when there is no or very low airflow over the heat exchanger. Repair the air handler fan, if necessary. Also, check to see if the unit is running with a variable-frequency drive. The minimum speed may be set too low.
			<ul style="list-style-type: none"> • <i>High Pressure Gas.</i> This switch trips if there is excessive gas pressure in the gas piping. Adjust the gas pressure regulator or contact the local gas utility.
	Combustion airflow switch contacts may be open	Unit locked out on flame failure; "Alarm" LED illuminated on flame-relay panel.	Press the Reset button to reset the flame relay and attempt to restart the gas heat module/section. If the unit continues to trip-out, see the troubleshooting symptom below.
			The combustion air motor may be overloaded. Press the Reset button on back side of the combustion air blower motor.
			The combustion air blower motor may be defective. Replace the motor.
The modulating gas valve end switch contacts may be open, indicating that the gas valve is not fully closed. Look for jammed linkages and repair as necessary.			
Replace the modulating gas valve and actuator.			
Check airflow switch sensor tubes for clogging or obstruction. Remove debris to clear tubes.			
Induced draft exhauster fan, if so equipped, airflow switch contacts may be open.		Check exhaust flue for obstructions. Clear obstructions.	
		Check inlet air damper for obstructions. Clear obstructions.	
		Check airflow switch sensor tubes for clogging or obstruction. Remove debris to clear tubes.	
		Check exhaust flue for obstructions. Clear obstructions.	
Unit only runs when service access door on piping vestibule is open	Combustion airflow switch contacts may be open.	Check if air balancing damper is closed. Open damper.	
		Check 3-phase wiring to unit for correct phasing. Motor may be running backwards.	
		Check combustion air inlet (into piping vestibule) for obstructions blocking entrance of combustion air. Remove obstructions or debris.	

Table 11. Troubleshooting gas heat sections (continued)

Symptom	Probable Cause	Recommended Action
Unit will not run, locks out on flame failure; "Alarm" LED illuminated on flame relay panel.	Flame sensor not sensing pilot flame	The manual gas valve may be closed; open it.
		(3:1 and 10:1 turndown burners) UV flame sensor may be dirty; check the lens for dirt, soot, and so on, and clean the lens, if necessary.
		Check the ignition cable and wiring for loose, frayed connections or broken wiring. Repair as necessary.
		Pilot solenoid valve may not be opening.
		Check for voltage at the pilot solenoid valve.
		Check for sufficient gas pressure in the pilot line and adjust the pilot pressure regulator.
		(20:1 Turndown Burners) Check flame rod for cleanliness, adequate grounding and that it is properly located in the flame. Also ensure that temperature at flame rod insulator is no greater than 500 F (260 C).
	Low flame signal voltage	Perform Ignition Interference Test per component manufacturers manual.
		Check flame signal voltage per procedure in Start-Up section.
		(3:1 and 10:1 turndown burners) UV flame sensor may be dirty; check lens for dirt, soot, and so on and clean the lens, if necessary.
CO is above 400 ppm.	Gas pressure not adjust properly.	The flame sensor may be defective; replace it.
		(20:1 turndown burners) Check flame rod for cleanliness, adequate grounding and that it is properly located in the flame. Also ensure that temperature at flame rod insulator is no greater than 500 F (260 C).
		Adjust gas pressure. See "Proper Gas Pressure," p. 18.

Trane - by Trane Technologies (NYSE: TT), a global climate innovator - creates comfortable, energy efficient indoor environments for commercial and residential applications. For more information, please visit trane.com or tranetechnologies.com.

Trane has a policy of continuous product and product data improvement and reserves the right to change design and specifications without notice. We are committed to using environmentally conscious print practices.