

INSTALLATION OPERATION MAINTENANCE

WCK-IOM-7
18-BB33D10-7

Models:

WCK024B1
WCK030B1
WCK036B1
WCK042B1

**Single Packaged
Heat Pump
2, 2-1/2, 3, 3-1/2 Tons**

IMPORTANT— This Document is customer property and is to remain with this unit. Please return to service information pack upon completion of work.

⚠ WARNING: HAZARDOUS VOLTAGE - DISCONNECT POWER BEFORE SERVICING

ALL phases of this installation must comply with NATIONAL, STATE, and LOCAL CODES.

These instructions do not purport to cover all variations in systems nor to provide for every possible contingency to be met in connection with installation. Should further information be desired or necessary or should particular problems arise which are not covered sufficiently for the purchaser's or installer's needs or purposes, the matter should be referred to the manufacturer.

⚠ WARNING

THIS INFORMATION IS FOR USE BY INDIVIDUALS HAVING ADEQUATE BACKGROUNDS OF ELECTRICAL AND MECHANICAL EXPERIENCE. ANY ATTEMPT TO REPAIR A CENTRAL AIR CONDITIONING PRODUCT MAY RESULT IN PERSONAL INJURY AND/OR PROPERTY DAMAGE. THE MANUFACTURER OR SELLER CANNOT BE RESPONSIBLE FOR THE INTERPRETATION OF THIS INFORMATION, NOR CAN IT ASSUME ANY LIABILITY IN CONNECTION WITH ITS USE.

⚠ CAUTION

Reconnect all grounding devices.

All parts of this product that are capable of conducting electrical current are grounded. If grounding wires, screws, straps, clips, nuts, or washers used to complete a path to ground are removed for service, they must be returned to their original position and properly fastened.

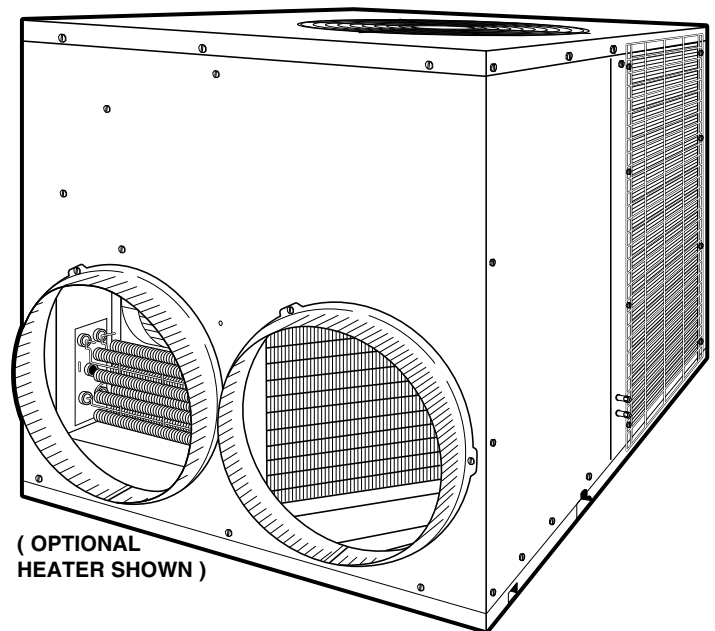

⚠ CAUTION

CONTAINS REFRIGERANT!
SYSTEM CONTAINS OIL AND REFRIGERANT UNDER HIGH PRESSURE. RECOVER REFRIGERANT TO RELIEVE PRESSURE BEFORE OPENING SYSTEM. Failure to follow proper procedures can result in personal illness or injury or severe equipment damage.

The manufacturer has a policy of continuous product and product data improvement and it reserves the right to change design and specification without notice.

General Information

These instructions cover installation, operation, and maintenance of all single package WCK air conditioning units. For an easy and orderly installation, follow the sequence of instructions as they are outlined. Improper installation can result in unsatisfactory operation and/or dangerous conditions as well as make the related warranty inapplicable. Read this manual carefully before installing, operating, or performing maintenance on this unit. Installation and maintenance should be performed by qualified service technicians. Locate the unit in accordance with local codes or the National Electrical Code. Each unit contained an operating charge of HCFC-22 when shipped.

Unit Inspection

The material in this shipment has been inspected at the factory and was released to the transportation agency without known damage. Inspect the exterior of the carton for evidence of rough handling in shipment. Check the unit nameplate to determine if the unit is correct for the intended application. After moving the equipment to the approximate location, unpack it carefully. If damage to the unit is found, report the nature of this damage immediately to the delivery agency. Check to be sure that the refrigerant charge has been retained during shipment.

Locations and Recommendations

These units are designed for outdoor installation. For proper installation, the following recommendations must be considered.

NOTE: Unit is for horizontal installation only.

The discharge air from the condenser fans must be unrestricted for a minimum of 3 feet above the unit.

NOTE: If any internal accessories are to be added to the unit it should be done at the shop if at all practical.

2. Unit should be positioned so Roof-Run-Off water does not pour directly on unit.
4. Exhaust vents or other sources of contaminated air should not be near unit air inlet if outside air is to be introduced as a make-up air.
5. Check the handling facilities to insure the safety of personnel and the unit(s).
6. CAUTION MUST BE TAKEN AT ALL TIMES TO AVOID PERSONAL INJURIES AND/OR DAMAGE TO EQUIPMENT.
7. The unit must be mounted level for proper drainage of defrost water through the holes in the base pan.
8. Flexible duct connectors must be of a flame retardant material. All duct work outside of the structure must be insulated and weatherproofed in accordance with local codes.
10. Holes through exterior walls must be sealed in accordance with local codes.
11. Access and service clearances for the unit must be given careful consideration when locating the duct entrance openings. Figure 1 provides unit dimensions.

Power Supply

The power supply must be adequate for the unit and any supplementary electric heaters, if added. Make certain that the power supply to the unit agrees with the power requirements specified on the unit nameplate. Separate branch circuits are required for supplementary electric heaters.

Rigging

IMPORTANT: Check the handling facilities to ensure the safety of both personnel and the unit. Be sure that the proper method of rigging is used, with straps or slings and spreader bars for protection during lifting.

WARNING

Do not lift the unit without testing for balance and rigging. Do not lift the unit in windy conditions or above personnel. Do not lift the unit by attaching a clevis, hooks, pins, or bolts to the unit casing, casing hardware, corner lugs, angles, tabs, or flanges. Failure to observe this warning may result in equipment damage.

12. All fabricated outdoor ducts should be as short as possible.

13. Be sure the hole in the structure for the ducts is large enough to accommodate the fabricated ducts and the insulation surrounding them. (See Figure 1.)

Clearances

1. The recommended clearances for single-unit installations are illustrated in Figure 1. These minimum requirements are not only an important consideration when determining unit placement, but they are also essential to ensure adequate serviceability, maximum capacity, and peak operating efficiency.
2. Any reduction of the unit clearances indicated in this illustration may result in condenser coil starvation, or the recirculation of warm condenser air. Actual clearances which appear to be inadequate should be reviewed with a local sales engineer.

Unit Support

If unit is to be roof mounted, check building codes for weight distribution requirements. Check unit nameplate for supply voltage required. Determine if adequate electrical power is available. Refer to specification sheet.

Location and Clearances

Installation of the unit should conform to local building codes or, in the absence of local codes, to the ANSI/NFPA No. 70-1987 National Electrical Code or "Latest Revision." Canadian installations must conform to CSA and local codes.

Select a location that will permit unobstructed airflow into the condenser coil and away from the fan discharge and permit unobstructed service access into the compressor compartment. Suggested airflow clearances and service clearances are given in Figure 1.

UNIT DIMENSIONS AND CLEARANCES

1

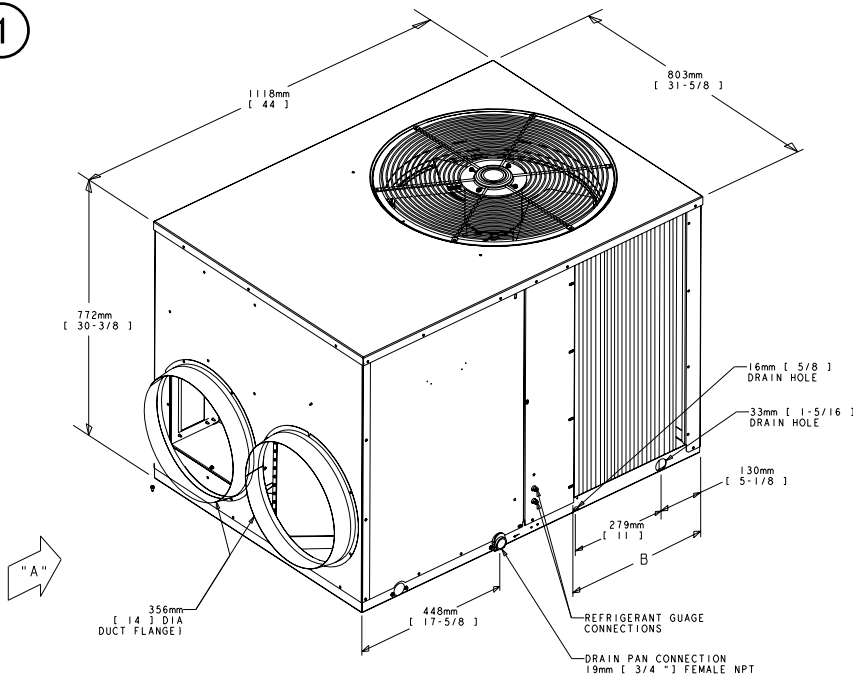

INSTALLATION / SERVICE CLEARANCE	
BACK	48.0"
LEFT SIDE	24.0"
RIGHT SIDE	36.0"
TOP	36.0"

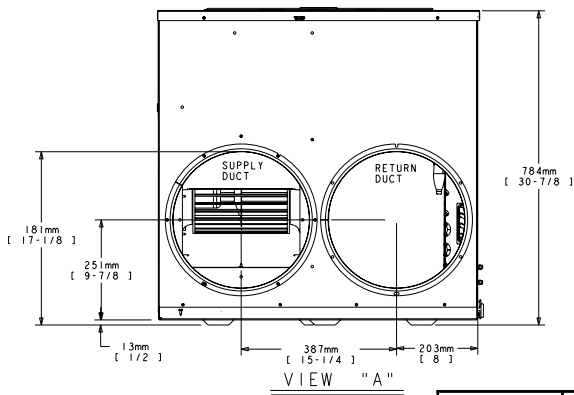
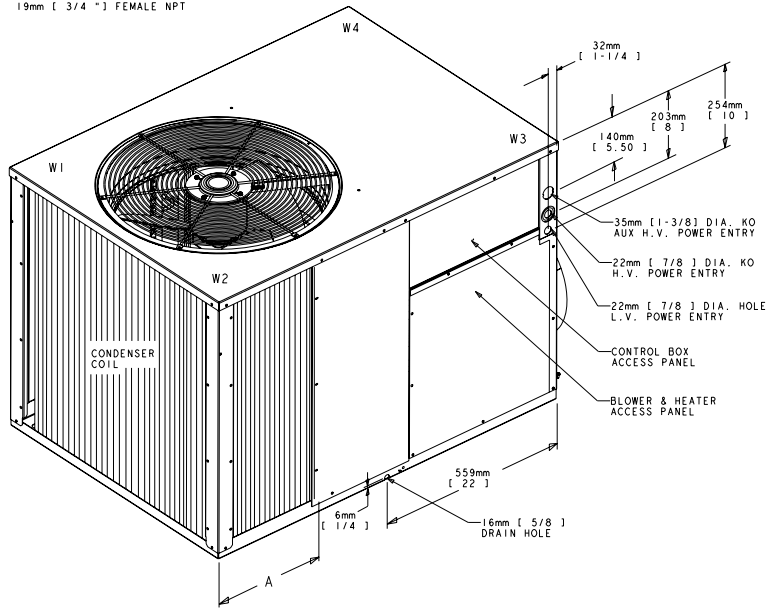

MODEL	APPROX. CORNER WEIGHT - KG/LBS				TOTAL WEIGHT KG/LBS	COIL DIMENSION	
	W1	W2	W3	W4		A	B
WCK042B1	36.30 (80)	41.30 (91)	34.00 (75)	30.40 (67)	141.90 (313)	441 (17-3/8)	413 (16-1/8)
WCK036B1	37.20 (82)	37.20 (82)	32.70 (72)	32.70 (72)	139.70 (308)	441 (17-3/8)	413 (16-1/8)
WCK030B1	33.60 (74)	37.20 (82)	33.60 (74)	30.40 (67)	135.20 (298)	302 (11-7/8)	413 (16-1/8)
WCK024B1	38.60 (85)	34.92 (77)	29.02 (64)	32.20 (71)	135.20 (298)	0	413 (16-1/8)
TCK042B1	34.90 (77)	37.20 (82)	34.90 (77)	32.70 (72)	139.70 (308)	441 (17-3/8)	413 (16-1/8)
TCK036B1	33.60 (74)	36.70 (81)	33.60 (74)	30.80 (68)	134.70 (297)	441 (17-3/8)	413 (16-1/8)
TCK030B1	30.80 (68)	38.60 (85)	34.90 (77)	28.10 (62)	131.90 (291)	302 (11-7/8)	413 (16-1/8)
TCK024B1	34.01 (75)	34.01 (75)	31.29 (69)	31.29 (69)	131.18 (287)	302 (11-7/8)	413 (16-1/8)

Installation

Ground Level -- Horizontal

For ground level installations, the unit should be positioned on a pad the size of the unit or larger. The unit must be level on the pad. The pad must not come in contact with the structure. Be sure the outdoor portion of the supply and return air ducts are as short as possible.

Proceed with the installation as follows:

1. Place the unit on the pad.
2. Attach the supply and return air ducts to the unit.
3. Insulate any ductwork outside of the structure with at least 2 inches of insulation and weatherproof. There must be a weatherproof seal where the duct enters the structure.
4. Complete the installation according to the instructions in the following sections of this manual.

Condensate Drain Piping

A 3/4-inch female NPT condensate drain connection is provided on the evaporator access panel end of the unit. See Figure 4. Provide a trap and fill it with water before starting the unit to avoid air from being drawn through. Follow local codes and standard piping practices when running the drain line. Pitch the line downward away from the unit. Avoid long horizontal runs. See Figure 2

NOTE: Do not use reducing fittings in the drain lines. The condensate drain must be:

- Made of 3/4" pipe size.
- Pitched 1/4" per foot to provide free drainage to convenient drain system.
- Trapped.
- Must not be connected to closed drain system.

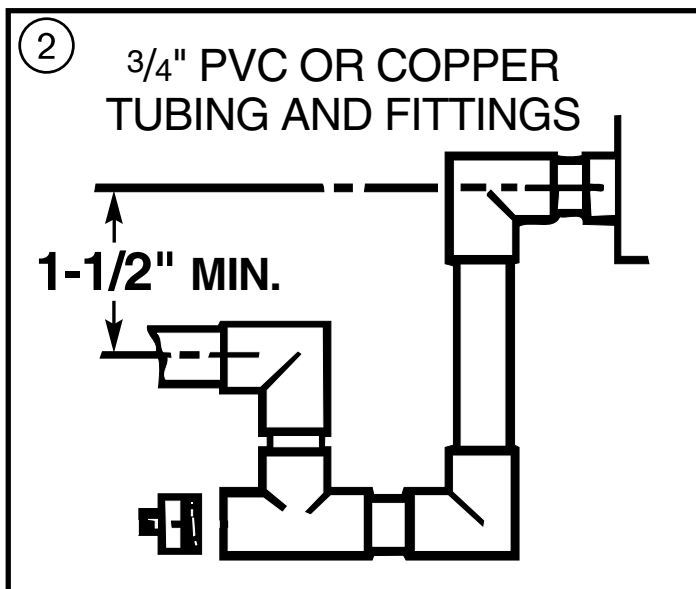

ATTACHING HORIZONTAL DUCTWORK TO UNIT

All conditioned air ductwork should be insulated to minimize heating and cooling duct losses. Use a minimum of two (2) inches of insulation with a vapor barrier. The outside ductwork must be weatherproofed between the unit and the building.

When attaching ductwork to a horizontal unit, provide a flexible watertight connection to prevent noise transmission from the unit to the ducts.

Note: Duct flanges are located in blower and heater compartment.

Electrical Wiring

⚠ WARNING: TO PREVENT INJURY OR DEATH DUE TO ELECTRICAL SHOCK OR CONTACT WITH MOVING PARTS. LOCK UNIT DISCONNECT SWITCH IN OPEN POSITION BEFORE SERVICING UNIT.

Electrical Connections

Electrical wiring and grounding must be installed in accordance with local codes or, in the absence of local codes, with the National Electrical Code ANSI/NFPA 70, Latest Revision.

Disconnect Switch

• Provide an approved weather-proof disconnect either on the side of the unit or within close proximity and **within sight of the unit**.

Over Current Protection

• The branch circuit feeding the unit must be protected as shown on the unit rating plate.

Power Wiring

• The power supply lines must be run in weathertight conduit to the disconnect and into the bottom of the unit control box. Provide strain relief for all conduit with suitable connectors.

• Provide flexible conduit supports whenever vibration transmission may cause a noise problem within the building structure.

• Ensure all connections are made tight. See Figures 5 and 6: Typical Field Wiring Diagrams.

NOTES:

1. For branch circuit wiring (main power supply to the unit disconnect), wire size for the length of run should be determined using the circuit ampacity found on the unit nameplate and the N.E.C.
2. For more than 3 conductors in a raceway or cable, see the N.E.C. for derating the ampacity of each conductor.
3. Wire size is based on 75 degrees C rated wire insulation.

Grounding

• The unit must be electrically grounded in accordance with local codes or the National Electrical Code.

— Sequence of Operation —

Accessories

•All electrical accessories must be installed and wired according to the instructions packaged with the accessory.

Control Wiring (Class II)

•Low voltage control wiring should not be run in the same conduit with the power wiring unless Class I wire of the proper voltage rating is used. Route the thermostat cable or equivalent single leads of No. 18 AWG colored wire from the thermostat subbase terminals through the rubber grommet on the unit. See Figure 1 for the control entry location. Make connections as shown on the unit wiring diagram and in Figures 5 and 6.

•Do not short thermostat wires since this will damage the control transformer.

•Recommended wire sizes and lengths for installing the unit thermostat are provided in **Table 1: Thermostat Wire Size and Maximum Length**. The total resistance of these low voltage wires must not exceed one (1) ohm. Any resistance in excess of one (1) ohm may cause the control to malfunction because of the excessive voltage drop.

•**IMPORTANT: Upon completion of wiring check all electrical connections, including factory wiring within the unit.** Make sure all connections are tight. Replace and secure all electrical box covers and access doors before leaving the unit or turning on the power to the unit.

•After all electrical wiring is complete, set the thermostat system switch on the **OFF** position so that the compressor will not run and then apply power by closing the system main disconnect switch. This will activate the compressor sump heat. Do not change the Thermostat System Switch until power has been applied long enough to evaporate any liquid HCFC-22 in the compressor. It is recommended that the sump heat be energized for a minimum of eight (8) hours prior to starting the unit.

**Table 1
Thermostat Wire Size and Maximum Length**

WIRE SIZE	MAXIMUM LENGTH (Ft)
18	75
16	125
14	200

— Air Filters —

•These units require filters with adequate filter area be provided in the return air duct. Table 2 below gives filter data. The specific location of the filters depends on the type of installation and the layout of the duct system. Be sure the owner is aware of the location of the filter and the need to change them as required. The Filter Size (Sq. Ft.) are based on 300 F.P.M. face velocity. If permanent filters are used, size per mfg. recommendation with clean resistance of .05" WC.

Table 2. Filter Data

UNIT	NOMINAL CFM	FILTER* (Sq Ft) SIZE	FILTER RESISTANCE
WCK024B	800	2.67	0.05
WCK030B	1000	3.33	0.05
WCK036B	1200	4.00	0.05
WCK042B	1400	4.67	0.05

GENERAL

Operation of the unit heating and cooling cycles is automatic for **HEAT** and **COOL** functions. (The optional automatic changeover thermostat, when in the **AUTO** position, automatically changes to heat or cool with sufficient room temperature change.) The fan switch can be placed in either the **ON** position, causing continuous evaporator (indoor) fan operation, or the **AUTO** position causing fan operation to coincide with heating or cooling run cycles. Continuous fan mode during cooling operation may not be appropriate in humid climates. If the indoor air exceeds 60% relative humidity or simply feels uncomfortably humid, it is recommended that the fan only be used in the **AUTO** mode.

COOLING MODE

(NOTE: **TSH** & **TSC** are contacts internal to the indoor thermostat.)

With the disconnect switch in the **ON** position, current is supplied to the compressor crankcase heater and control transformer. The cooling cycle is enabled through the low voltage side of the control transformer to the **"R"** terminal on the indoor thermostat. With the system switch in the **AUTO** position and **TSC-1** contacts closed, power is supplied to the **"O"** terminal on the indoor thermostat to the switchover valve coil (**SOV**). This energizes the switch-over valve (**SOV**) and places it in the cooling position (it is in the heating position when not energized).

When the indoor temperature rises 1-1/2 degrees, **TSC-2** contacts close, supplying power to the **"Y"** terminal on the indoor thermostat, and to the compressor contactor (**CC**). This starts the outdoor fan motor and compressor. The **TSC-2** contacts also provide power to the **"G"** terminal which provides power to the fan relay (**F**) and motor speed tap terminal and starting the indoor fan motor.

HEATING MODE

With the disconnect switch in the **"ON"** position, current is supplied to the control transformer. Starting at the **"R"** terminal on the indoor thermostat, current goes through the system switch (which is in **"AUTO"** position) to the **TSH-1** contacts. When closed, these contacts supply power to terminal **"Y"** on the indoor thermostat as well as to the heating anticipator. The switch-over valve will not energize because of the high resistance of the heating anticipator in the thermostat. Power is provided from **"Y"** to the compressor contactor (**CC**) which starts the outdoor fan motor and compressor. The indoor thermostat contact **TSH-1** also provides power to **"G"** terminal on the indoor thermostat energizing the fan relay (**F**), and motor speed tap terminal, which starts the indoor fan motor

SUPPLEMENTARY HEAT

The supplementary electric heat is brought on when the indoor temperature drops 1-1/2 degrees below the thermostat setting. **TSH-2** contacts close providing power to the **"W"** terminal on the indoor thermostat and to the supplementary heater control circuit. *NOTE:* The fan relay (**F**) must have been energized. An outdoor thermostat may have been added to disallow the second stage (if provided) of electric heat above a selected outdoor temperature. If the outdoor temperature falls below the setting on the outdoor thermostat, this additional heater stage will come on. When the outdoor air temperature rises, and the outdoor T-stat setpoint is reached, the system will revert back to first stage electric heating.

When the indoor ambient is satisfied, **TSH-2** contacts will open

Sequence of Operation

and the unit will revert back to the compressor only heating mode and then off. For **emergency heat** (use of supplementary electric heat only), an emergency (**EMERG**) heat switch is provided within the thermostat. When placed in the emergency heat position, it will disable the compressor, bypass the outdoor thermostats, if provided, and engage the supplementary electric heaters and indoor fan.

DEMAND DEFROST OPERATION

During the heating cycle, the outdoor coil may require a defrost cycle which is determined by the demand defrost control (**DFC**). This control continuously measures the outdoor coil temperature (**CBS**) and the outdoor ambient temperature (**ODS-B**) and calculates the difference or delta-T measurement. When the calculated delta-T is met, the demand defrost control (**DFC**) opens the circuit to the outdoor fan motor (**ODM**) and energizes the switch-over valve (**SOV**), placing the unit in the cooling mode to defrost the outdoor coil. The outdoor coil temperature sensor (**CBS**) terminates the defrost cycle, or times off after twelve minutes in defrost, the (**DFC**) energizes the outdoor fan motor (**ODM**) and fifteen seconds later de-energizes the (**SOV**), which returns the unit to the heating mode. Supplementary electric heat, if provided, is brought on to control indoor temperature during the defrost cycle.

The following warning complies with State of California law, Proposition 65.

⚠ WARNING: This product contains **fiberglass wool insulation!** Fiberglass dust and ceramic fibers are believed by the State of California to cause cancer through inhalation. Glasswool fibers may also cause respiratory, skin, or eye irritation.

PRECAUTIONARY MEASURES

- Avoid breathing fiberglass dust.
- Use a NIOSH approved dust/mist respirator.
- Avoid contact with the skin or eyes. Wear long-sleeved, loose-fitting clothing, gloves, and eye protection.
- Wash clothes separately from other clothing: rinse washer thoroughly.
- Operations such as sawing, blowing, tear-out, and spraying may generate fiber concentrations requiring additional respiratory protection. Use the appropriate NIOSH approved respirator in these situations.

FIRST AID MEASURES

Eye Contact - Flush eyes with water to remove dust. If symptoms persist, seek medical attention.

Skin Contact - Wash affected areas gently with soap and warm water after handling.

Important Product Information

Registering your products helps provide you with one of the strongest manufacturer limited warranties available. To register, go to the manufacturer's website or contact your dealer. You will need the serial number, model number, and installation date for each product being registered. Your dealer may have included these on your invoice or can provide a list for you to use. Please take a few moments to record the following information to ensure your product registration process is quick and easy:

Packaged Unit Serial Number _____

Packaged Unit Model Number _____

Date of Installation _____

Dealer _____

Service Information

Call your installing dealer if the unit is inoperative. Before you call, always check the following to be sure service is required:

- a. Be sure the main switch that supplies power to the unit is in the ON position.
- b. Replace any burned-out fuses or reset circuit breakers.
- c. Be sure the thermostat is properly set.

Service Phone _____

Typical Field Wiring Diagram

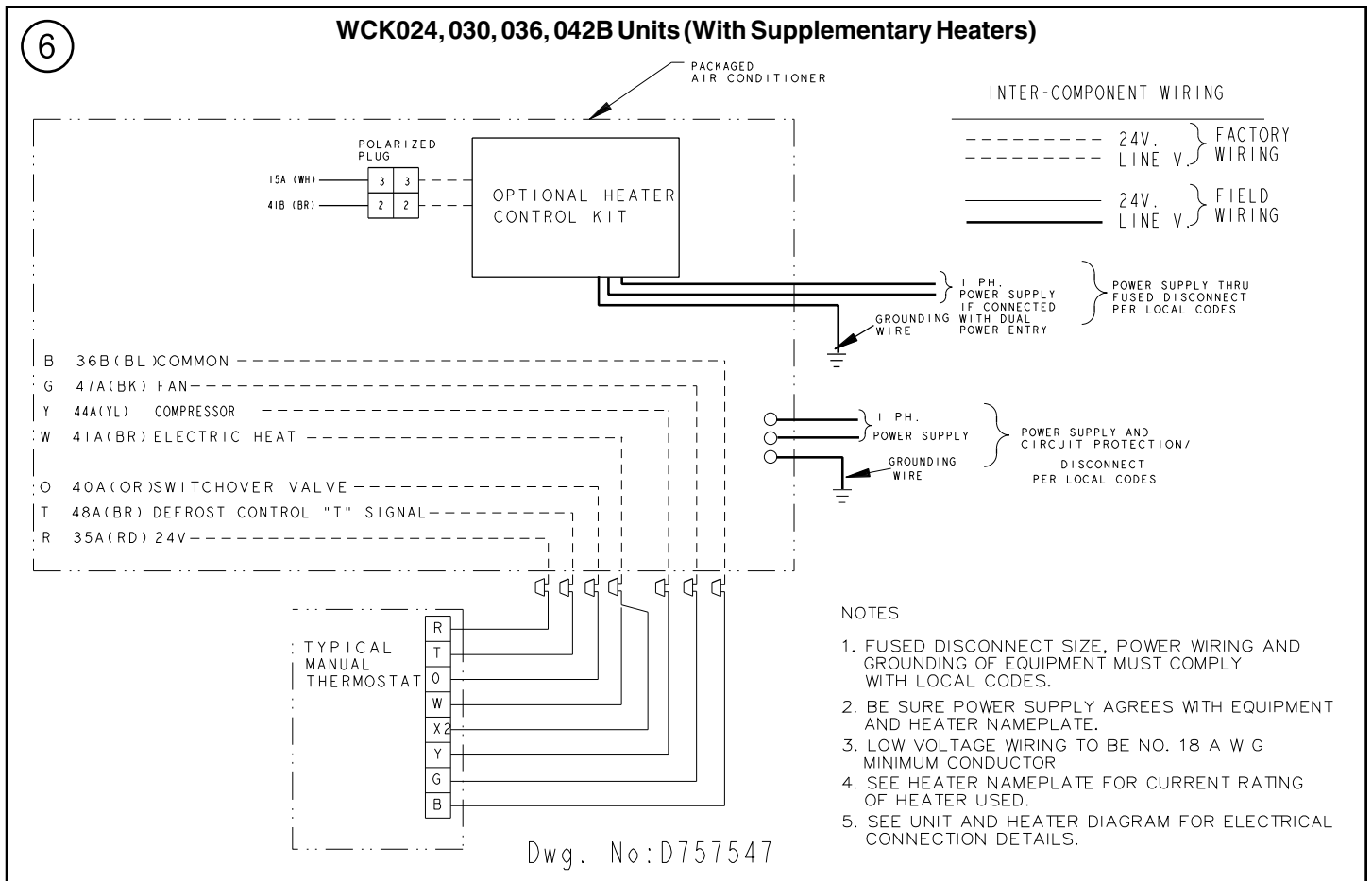

Maintenance

Routine Maintenance by Owner

You can do some of the periodic maintenance functions for your WCK unit yourself. These functions include replacing the disposable or cleaning the permanent air filters, cleaning the unit's cabinet, cleaning the condenser coil, and conducting a general inspection of the unit on a regular basis.

WARNING: TO PREVENT INJURY OR DEATH DUE TO ELECTRICAL SHOCK OR CONTACT WITH MOVING PARTS. LOCK UNIT DISCONNECT SWITCH IN OPEN POSITION BEFORE SERVICING UNIT.

Air Filters

- It is very important to keep the central duct system air filters clean. Be sure to inspect them at least once each month when the system is in constant operation. In new construction, check the filters every week for the first four (4) weeks.
- If you have disposable-type filters, replace them with new filters of the same type and size. Do not try to clean disposable filters.
- Clean permanent-type filters by washing them with a mild detergent and water. Make sure that the filters are thoroughly dry before re-installing them in the unit.
- Replace permanent filters annually if washing fails to clean them or if they show signs of deterioration. Use the same type and size as was originally installed.

Outdoor Coil

- Unfiltered air circulated through the unit's outdoor coil can cause the coil's surface to become clogged with dust, dirt, etc. To clean the coil, stroke the coil surface with a soft-bristled brush vertically, that is, in the direction of the fins.
- Be sure to keep all vegetation away from the outdoor coil area.

Maintenance Performed by Serviceman

To keep your unit operating as designed, the manufacturer recommends that a qualified serviceman check over the entire system at least once each year as well as any other time that you feel that one is needed. Your serviceman should examine and inspect:

- filters (for cleaning or replacement)
- motors and drive system components
- condenser coils (for cleaning)
- safety controls (for mechanical cleaning)
- electrical components and wiring (for possible replacement and/or connection tightness)
- condensate drain (for cleaning)
- unit duct connections (to see that they are physically sound and sealed to the unit casing)
- unit mounting support (for structural integrity)
- unit to see that there is no obvious unit deterioration.

Demand Defrost System

DEFROST CONTROL

The demand defrost control measures heat pump outdoor ambient temperature with a sensor located outside the outdoor coil. A second sensor located on the outdoor coil is used to measure the coil temperature. The difference between the ambient and the colder coil temperature is the difference or delta-T measurement. This delta-T measurement is representative of the operating state and relative capacity of the heat pump system. By measuring the change in delta-T, we can determine the need for defrost. The coil sensor also serves to sense outdoor coil temperature for termination of the defrost cycle.

FAULT DETECTION

A fault condition is indicated by the flashing light on the defrost control inside the heat pump control box.

In normal operation, the defrost control light will flash once each second. If the light is flashing more than once per second or not-at-all, refer to the service manual for that unit.

PIN IDENTIFICATION (See Figure)

1. TEST_COMMON (Shorting any of the other pins to this pin causes the function of the other pin to be executed. Leaving this pin open results in the normal mode of operation.)
2. TST = Test (Shorting TEST_COMMON to this pin speeds up all defrost board timings.)
3. FRC_DFT = Forced Defrost (Short TEST_COMMON to this pin for two (2) seconds to initiate a forced defrost. Remove the short after defrost initiates.)

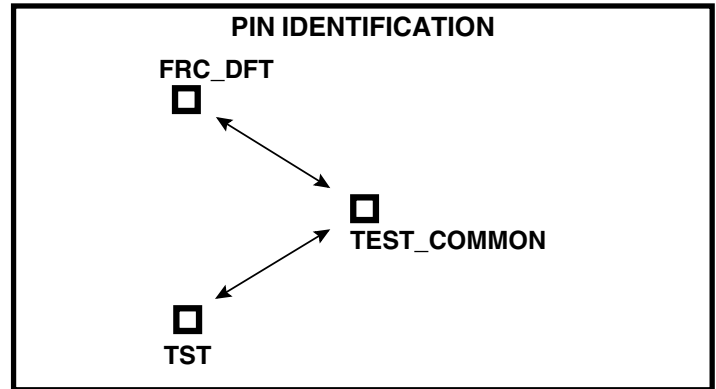

DEFROST CONTROL CHECKOUT

Normal operation requires:

- a. LED on board flashing 1 time/second.
- b. 24V AC between R & B
- c. 24V AC between Y & B with unit operating
- d. Defrost initiation when FRC_DFT pin is shorted to TEST_COMMON pin.

If a defrost control problem is suspected, proceed to DEMAND DEFROST CONTROL CHECKOUT in this Service Facts.

⚠ WARNING: Do NOT connect 24 VAC to T1 (ODS-A) terminal. ODS-A thermistor WILL BE BLOWN.

PROCEDURE FOR TESTING SENSORS

Measure the temperature the subject sensor is exposed to. If the sensor is mounted on a tube, place the lead on an Annie A-8 (or equiv.) temperature tester on the same tube near the sensor and insulate the bulb.

Unplug the sensor and measure the resistance with a good quality ohmmeter (Simpson 260 or equiv.). Read the value as quickly as possible to prevent the meter current from changing the resistance reading.

Using the chart on the right, locate (as close as possible) the actual sensor temperature. The measured resistance should be relatively close to the resistance value shown in the chart.

Example:

Sensor temp. = 19°F.
 Measured Resistance = 46K ohms
 This sensor is good since the measured value is relatively close to the chart value.

TEMP °F	RESISTANCE
86	7.85K
81	8.85K
75	10.24K
70	11.59K
65	13.14K
59	15.32K
55	16.93K
50	19.41K
45	22.20K
41	24.76K
36	28.45K
32	31.84K
25	37.50K
19	46.44K
14	53.94K
10	57.64K
5	67.06K
0	78.05K

FLASH RATE INDICATIONS:

- 1 — Flash/Second = Normal operation.
- 2 — Flashes/Second = Fault A (Low ΔT) i.e.: Inoperative compressor, loss of charge, open ambient sensor, shorted coil sensor.
- 3 — Flashes/Second = Fault B (20 defrosts terminated on time)
 Fault C (High ΔT) i.e.: SOV stuck in heating, shorted ambient sensor, open coil sensor, closed TXV, OD motor failure, OD fan on in defrost, undercharged unit.
- 4 — Flashes/Second = Fault A & C or A & B

For additional information consult Pub. No. 34-1001 Heat Pump Defrost Controls.

Demand Defrost Control Checkout

SYMPTOMS	CHECKS	YES/NO	ACTIONS
1. LED off.	1. 24V R-B & Y-B at board, with unit running?	N	Repair low voltage wiring.
		Y	Complete Check #2.
	2.Short FRC_DFT pin to TEST_COMMON pin. Is defrost cycle initiated?	N	Replace defrost control.
		Y	LED is bad but control will still function.
2. LED flashing very rapidly (greater than 4 times/sec) or appears to be on continuously.	TEST_COMMON pin shorted to TST pin?	Y	Remove short.
		N	Replace defrost control.
3. Control does not initiate a normal defrost.	OD Temp. below 49°F. OD Coil temp. below 35°F? "Delta" T increasing?	N	Check refrigerant circuits for balanced distribution of refrigerant if OD coil is frosting and delta T is not increasing
	1. LED flashing?	N	Refer to SYMPTOM #1.
		Y	Complete Check #2.
	2. Check for 24V Y-B at board with unit running.	N	Repair low voltage wiring.
		Y	Complete Check #3.
	3. Check sensors for correct mounting (connection) and resistance.		Remount or replace sensor if necessary.
	4. Short FRC_DFT pin to TEST_COMMON pin. Is defrost cycle initiated?	N	Replace defrost control.
		Y	Y-B signal or control may be intermittent
4. Control does not initiate a forced defrost.	24V R-B & Y-B at board with unit running?	N	Repair low voltage wiring.
		Y	Replace defrost control.
5. Defrost initiates manually but terminates in less than 10 seconds.			Replace defrost control.
6. Defrost initiates manually but terminates on time.	1. Coil sensor circuit open or reading at a very high resistance?	Y	Replace coil sensor.
	2. Does OD fan cycle off in defrost?	N	Replace defrost control.
	3. Windy weather preventing normal termination?		
7. Defrost initiates on approximately 15/25 minute intervals.	Be sure OD coil is clean.	N	Complete Check #2.
	1. Coil sensor open or reading a very high resistance?	Y	Replace coil sensor.
	2. Ambient sensor reading less than normal?	N	Complete Check #3.
		Y	Replace ambient sensor.
3. OD fan off in defrost?	N	Replace defrost control.	
8. Defrost initiates on approximately 30/45 minute intervals.	1.TEST_COMMON pin shorted to TST pin?	Y	Remove short.
	2. Do both sensors check OK?	N	Replace defective sensor (Clear coil and reset Emergency heat light).
		Y	Complete SYMPTOM #3.
	3. Verify correct system charge.		Adjust as needed.
	4. Verify a "forced defrost" terminates less than 15 minutes.	N	Replace defrost control.
	5. OD fan motor off in defrost.		See SYMPTOM #9.
6. Verify proper SOV operation.		Replace if necessary.	
9. OD fan runs during defrost.			Replace defrost control.
10. No SOV delay on defrost termination.	Has J1 been cut?	Y	The soft-switch time is defeated when J1 is cut.
		N	Replace defrost control.
11. ODS-A burned out.	1. B to T greater than 10 volts?	Y	Check low voltage wiring for miswire.
		N	Check for short in low voltage wiring.
12. On SCROLL bearing units, compressor does not operate.	1. 24V R-B at board & 24V Y-B at board?	N	Repair low voltage wiring.
	2. Check protective devices in YO circuit . 24V YO-B present after 30 seconds.	N	Y-B signal or control may be intermittent
13. On SCROLL bearing units, no 30 second off delay at defrost initiation.	Check voltage between control terminals 2 and 7,force a defrost cycle. Is 24V present for 30 seconds and 0V thereafter?	N	Replace defrost control.

Start-Up

Pre-Start Quick Check List

- Is the unit properly and securely located and level with the proper clearance?
- Is the ductwork correctly sized, run, taped, insulated and weatherproofed with the proper unit arrangement?
- Is the condensate line properly sized, run, trapped, and pitched? Does it drain freely?
- Is the filter of the correct size and number? Are the supply and return registers unobstructed?
- Is the wiring properly sized and run according to the Unit Wiring Diagram, Figures 5 and 6?
- Is the power supply correct for the unit's requirements?
- Are all wiring connections, including those in the unit itself, tight?
- Is the thermostat well located, level, correctly wired, and accurately adjusted?
- Do the outdoor fan and the indoor fan turn free without rubbing? Are both fans tight on their shafts?
- Has the indoor blower speed tap been determined and the proper speed set? See the Unit Wiring Diagram, Figures 5 and 6.
- Has all work been done in accordance to the applicable local and national codes?
- Are all cover and access panels in place to prevent air loss and to protect against safety hazards?
- Have all tools and debris around, on top of, and under the unit been removed?

Starting the Unit In the Cooling Mode

IMPORTANT: Before starting the system in the cooling cycle, turn the thermostat switch to "OFF" and close the unit disconnect switch. This procedure energizes the compressor crankcase heat (if equipped) thereby vaporizing any liquid HCFC-22 in the crankcase. This is a precaution against foaming at start-up which could damage the compressor. Allow the heat to operate for a minimum of eight (8) hours.

NOTE: See the section on "Sequence of Operation" for a description of the cooling operating sequence.

- To start the unit in the cooling mode, set the thermostat system switch to **COOL**. Move the thermostat **COOL** indicator to a setting below room temperature. The outdoor fan motor, compressor, and evaporator fan motor will operate automatically.

Operating Pressures

After the unit has operated in the cooling mode for a short time, install pressure gauges on the gauge ports of the discharge and suction line valves. Check the suction and discharge pressures and compare them to the normal operating pressures provided in the unit's **SERVICE FACTS**.

Voltage

With the compressor operating, check the line voltage at the unit. The voltage should be within the range shown on the unit nameplate. If low voltage is encountered, check the size and length of the supply line from the main disconnect to the unit. The line may be undersized for the length of the run.

Start-Up

Cooling Shut Down

- Place the system selector switch in the **OFF** position or reset the thermostat at a setting above the room temperature.
- Do not de-energize the main power disconnect except when the unit is to be serviced. Power is required to keep the compressor crankcase heat (if equipped) energized and boil off refrigerant in the compressor.

Starting the Unit in the Heating Mode

NOTE: See the section on "Sequence of Operation" for a description of the heating operating sequence.

- Check to make sure that all grilles and registers are open and all unit access doors are closed before start-up.
- To start the unit in the heating mode, set the thermostat system switch to **HEAT**. Move the thermostat **HEAT** indicator to a setting above room temperature and place the fan switch in the **AUTO** or **ON** positions. The indoor fan motor will operate automatically.
- The thermostat must provide a "G" signal for fan operation. If using an auto changeover thermostat, see Figures 5 and 6 for the appropriate connections.

Heating Shut-Down

- Place the system selector switch to the **OFF** position or place the heating selector lever at a setting below the room temperature.

The following warning complies with State of California law, Proposition 65.

⚠ WARNING: This product contains fiberglass wool insulation! Fiberglass dust and ceramic fibers are believed by the State of California to cause cancer through inhalation. Glasswool fibers may also cause respiratory, skin, or eye irritation.

**Base Limited Warranty
Packaged Air Conditioner and Packaged Heat Pump
TCK, TCH, WCK, WCH (Parts Only)
Models Less Than 20 Tons for Residential Use***

This limited warranty is provided by the manufacturer to the original purchaser and to any succeeding owner of the real property to which the Packaged Air Conditioner or Packaged Heat Pump (packaged unit) is originally affixed, and applies to products purchased and retained for use within the U.S.A. and Canada.

Beginning on January 1, 2010, R-22 refrigerant will no longer be used as a manufacturer-installed refrigerant as required by federal regulation. Following this date, depending on the availability of any remaining R-22 equipment, packaged unit model replacements may require that the entire system be R-410A compatible. Packaged units and possibly connecting line sets would need to be replaced in order to be compatible with R-410A refrigerant. Expenses associated with replacing system components that are not R-410A compatible will not be covered by the terms and conditions of the limited warranty.

The limited warranty period begins when installation is complete and the packaged unit start-up procedure has been properly completed, verified by installer's invoice or similar document. If installation completion and start-up date cannot be verified by installer's invoice or similar document, this limited warranty coverage begins six (6) months after the date of manufacture based on the packaged unit serial number.

If the sealed motor compressor fails or the outdoor coil becomes defective, or any functional part of your packaged unit fails because of manufacturing defect, within five (5) years from the date the limited warranty period begins, Warrantor will furnish without charge the required replacement compressor, coil, or functional part. Any other costs, such as local transportation, related service labor, diagnosis calls, refrigerant and related items are not included.

This limited warranty does not apply if the packaged unit was purchased direct (i.e. from internet websites or auctions) on an uninstalled basis. Additionally, this limited warranty will not apply unless the packaged unit is: (1) installed by a licensed or qualified HVAC technician, (2) applied and installed in accordance with the manufacturer's recommendations and its Installer's guide and (3) in compliance with all industry standards, national, state and local codes.

This limited warranty does not cover failure of your packaged unit if it is damaged while in your possession; including, but not limited to (1) damage caused by unreasonable use, (2) damage from failure to properly maintain as set forth in the Use and Care manual or Installer's Guide, (3) damage that is not considered a manufacturing defect, such as acts of God, malfunctions or failures resulting from fire, water, storms, lightning, earthquake, theft, riot, misuse, abuse, increased utility usage costs, or (4) performance problems due to improper selection/equipment match, installation or application.

This limited warranty applies to product installed on or after 5/1/2009.

THE LIMITED WARRANTY AND LIABILITY SET FORTH HEREIN ARE IN LIEU OF ALL OTHER WARRANTIES AND LIABILITIES, WHETHER IN CONTRACT OR IN NEGLIGENCE, EXPRESS OR IMPLIED, IN LAW OR IN FACT, INCLUDING BUT NOT SPECIFICALLY LIMITED TO IMPLIED WARRANTIES OF MERCHANTABILITY AND FITNESS FOR PARTICULAR USE, AND IN NO EVENT SHALL WARRANTOR BE LIABLE FOR ANY INCIDENTAL OR CONSEQUENTIAL DAMAGES.

Some states and provinces do not allow limitations on how long an implied limited warranty lasts or do not allow the exclusion or limitation of incidental or conse-quential damages, so the above limitation or exclusion may not apply to you. This limited warranty gives you specific legal rights, and you may also have other rights which vary by jurisdiction.

Parts will be provided by our factory organization through an authorized service organization in your area listed in the yellow pages.

If you wish further help or information concerning this limited warranty, contact:

Residential Systems
6200 Troup Highway, Tyler, TX 75707
Attention: Customer Relations

TW-1048-1409

* This limited warranty is for residential usage of this equipment and not applicable when this equipment is used for a commercial application.

A commercial use is any application where the end purchaser uses the product for other than personal, family or household purposes.

Limited Warranty High Efficiency Heat Pump 4WCZ6, 4WCY4, 2/4WCC3, 2/4WCX3, WCZ, WCD, WCH, WCK, WSC (Parts Only)

Models Less Than 20 Tons for Commercial Use*

This limited warranty is extended by the manufacturer to the original purchaser and to any succeeding owner of the real property to which the Heat Pump is originally affixed, and applies to products purchased and retained for use within the U.S.A. and Canada. There is no warranty against corrosion, erosion or deterioration.

Beginning on January 1, 2010, R-22 refrigerant will no longer be used as a manufacturer-installed refrigerant as required by federal regulation. Following this date, depending on the availability of any remaining R-22 equipment, packaged unit model replacements may require that the entire system be R-410A compatible. Packaged units and possibly connecting line sets would need to be replaced in order to be compatible with R-410A refrigerant. Expenses associated with replacing system components that are not R-410A compatible will not be covered by the terms and conditions of the limited warranty.

The limited warranty period begins when installation is complete and the packaged unit start-up procedure has been properly completed, verified by installer's invoice or similar document. If installation completion and start-up date cannot be verified by installer's invoice or similar document, limited warranty coverage begins six (6) months after the date of manufacture based on the packaged unit serial number.

If any part of your Heat Pump fails because of a manufacturing defect within one year from the date the limited warranty period begins, Warrantor will furnish without charge the required replacement part. In addition, if the sealed motor-compressor fails because of a manufacturing defect within the second through fifth year from the date the limited warranty period begins, Warrantor will furnish without charge the required replacement compressor. Warrantor's obligations and liabilities under this warranty are limited to furnishing F.O.B. Warrantor factory or warehouse replacement parts for Warrantor's products covered under this warranty. Warrantor shall not be obligated to pay for the cost of lost refrigerant. No liability shall attach to Warrantor until products have been paid for and then liability shall be limited solely to the purchase price of the equipment under warranty shown to be defective.

This limited warranty does not apply if the packaged unit was purchased direct (i.e. from internet websites or auctions) on an uninstalled basis. Additionally, this limited warranty will not apply unless the packaged unit is: (1) installed by a licensed or qualified HVAC technician, (2) applied and installed in accordance with the manufacturer's recommendations and its Installer's guide and (3) in compliance with all industry standards, national, state and local codes.

This limited warranty does not cover failure of your packaged unit if it is damaged while in your possession; including, but not limited to (1) damage caused by unreasonable use, (2) damage from failure to properly maintain as set forth in the Use and Care manual or Installer's Guide (refer to "Proper Maintenance" section), (3) damage that is not considered a manufacturing defect, such as acts of God, malfunctions or failures resulting from fire, water, storms, lightning, earthquake, faulty power supply or power surges, corrosive environments, insect or vermin infestation, theft, riot, misuse, abuse, increased utility usage costs, or (4) performance problems due to improper selection / equipment matchup, installation or application.

THE WARRANTY AND LIABILITY SET FORTH HEREIN ARE IN LIEU OF ALL OTHER WARRANTIES AND LIABILITIES, WHETHER IN CONTRACT OR IN NEGLIGENCE, EXPRESS OR IMPLIED, IN LAW OR IN FACT, INCLUDING IMPLIED WARRANTIES OF MERCHANTABILITY AND FITNESS FOR PARTICULAR USE, AND IN NO EVENT SHALL WARRANTOR BE LIABLE FOR ANY INCIDENTAL OR CONSEQUENTIAL DAMAGES.

Some states do not allow limitations on how long an implied warranty lasts or do not allow the exclusion or limitation of incidental or consequential damages, so the above limitation or exclusion may not apply to you.

This warranty gives you specific legal rights, and you may also have other rights which vary from state to state.

Residential Systems
6200 Troup Highway, Tyler, TX 75707
Attention: Consumer Relations

Or visit our website: www.trane.com/residential

TW-1005-3308

* This warranty is for commercial usage of said equipment and not applicable when the equipment is used for a residential application. Commercial use is any application where the end purchaser uses the product for other than personal, family or household purposes.

The limited warranties displayed in this publication and/or on ComfortSite™ may not accurately reflect the actual limited warranty that shipped with the product.

26-1000-22